

INTEGRA PELLET STOVE

Table of Contents

	Page
1. Electrical Components	2
2. Other Components	10
3. Function of the Stove	12
4. Installation	19
5. Pre-Burn Procedures	22
6. Maintenance Schedules	24
7. Troubleshooting	27
8. Different Readings	34
9. Schematics	36
10. Differences between the Integra Pellet Stoves	37
11. Schematics with Surge Protector	38

Mountain View Hearth Products
manuals.stove-parts-unlimited.com

1. ELECTRICAL COMPONENTS:

1.1 COMBUSTION MOTOR:

Manufactured by EBM, Germany, the combustion motor has sealed ball bearings and cast aluminium housing for even exhaust pressure and quiet operation. A Hall IC circuit measures RPMs of the motor, and the motor is capacitor protected against fluctuations in current.

- > Stainless Steel Impellar
- > 115 Volt; 0.31 Amps, 60 Hz.
- > RPM range: 500 - 2300 RPM
- > UL listed
- > Serial #: R2E-150-An89-11 (with Hall IC)
- > cfm = 97cuft/min

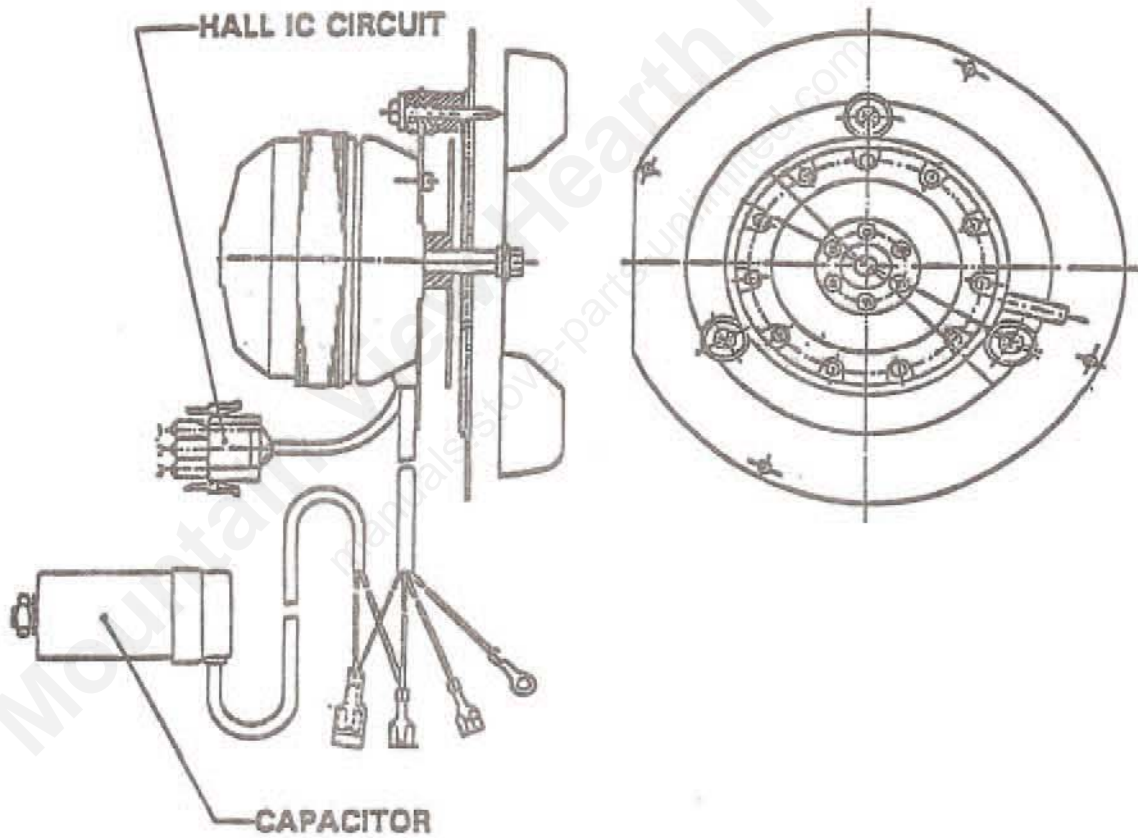

1.2 CONVECTION MOTOR:

The convection motor's shape and positioning moves cold air directly through the large volume convection air tubes. Built by Heidolph, Germany, it has its own cooling fan to provide long life.

- > 115 Volts; 1.1 Amps, 60 Hz.
- > RPM range: 1350 - 2450 RPM
- > UL listed
- > Serial #: 832 010 0164
- > cfm = 210 cuft/min

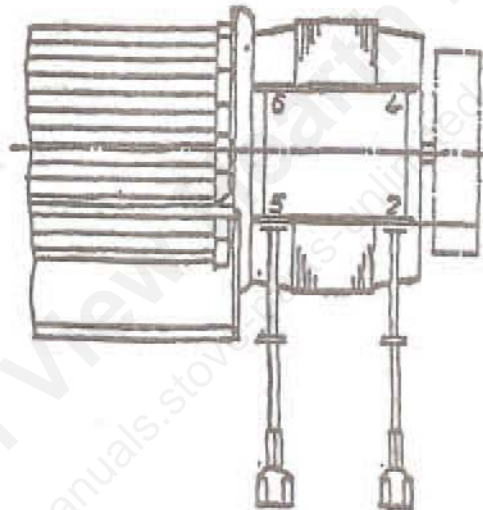

1.3 AUGER MOTOR:

Made in the USA by Merkle Korff this auger motor is a low RPM gear motor and is popular among many pellet stove manufacturers.

> 120 Volts; 0.55 Amps, 60 Hz.

> 1.1 RPM

> UL listed

> Serial #: GF X 4728 Rev. D

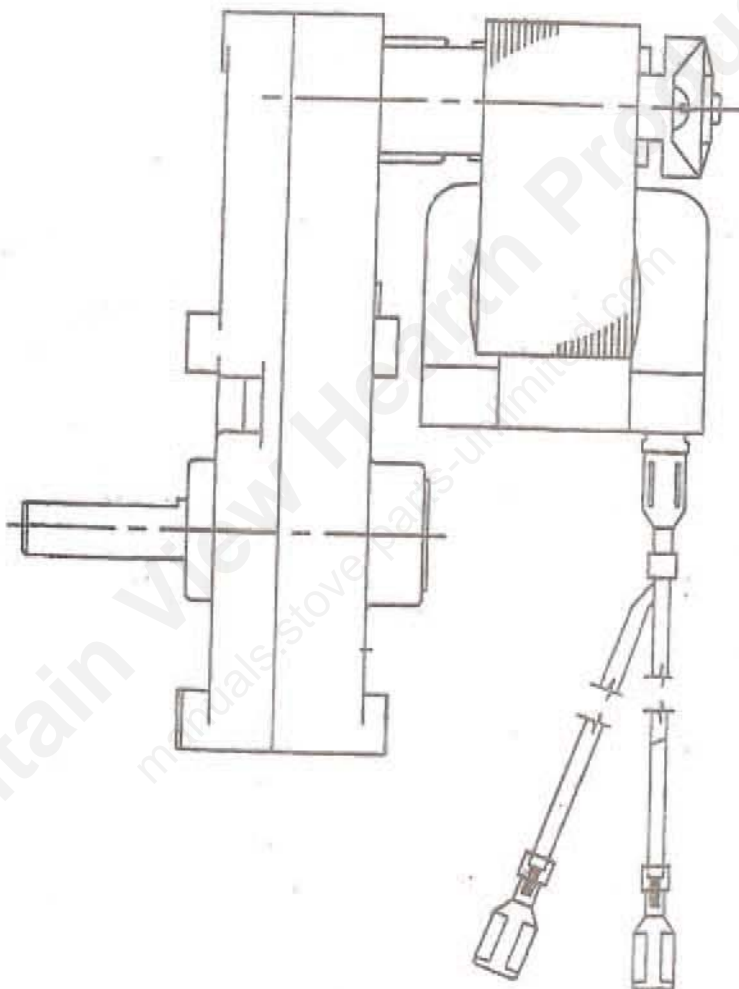

1.4 HIGH LIMIT SWITCH:

The high limit switch is closed when the stove is cold. The high limit switch shuts down auger feed in the event of overheating in the stove body. This switch is a bi-metal switch that opens at 250° F (+ - 7).

- > closing temp. 201° F
- > manufactured by STEMCO (USA)
- > normally closed switch

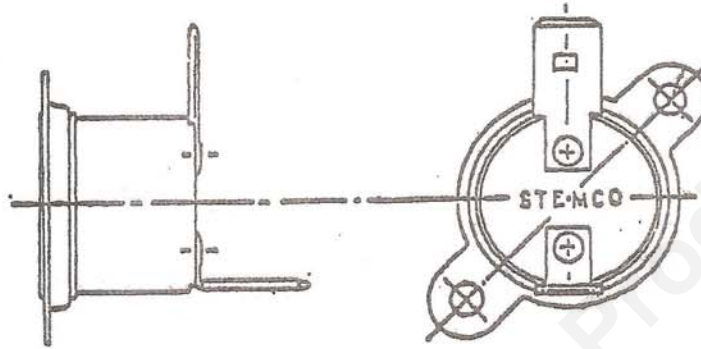

1.5 LOW LIMIT SWITCH:

The low limit switch is open when the stove is cold. The switch closes when the stove reaches operating temperature during the start up cycle; it closes at 120° F (+ - 6). The low limit switch also shuts down the convection fan and the auger motor during cool down.

- > opening temp. 110° F (+ - 5)
- > 120 Volts AC bi-metal switch
- > manufactured by Therm O Disc

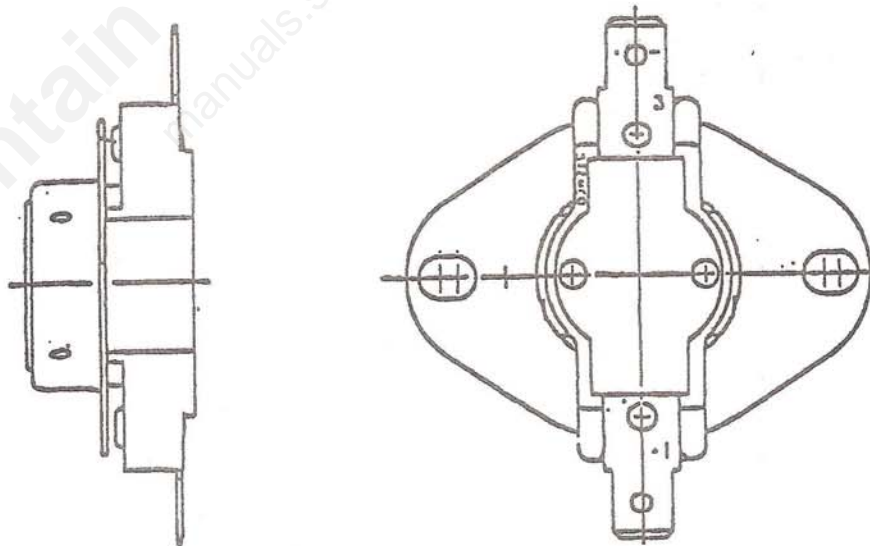

1.6 TERMINAL BLOCK AND WIRING HARNESS:

The terminal block (PVC) is the connection for all electrical components of the stove. The wiring harness provides the mount for the circuit board. Ensuring proper connection of all motors and circuits is essential for correct operation.
> manufactured by Woo Young Co.

TERMINAL BLOCK DIAGRAM

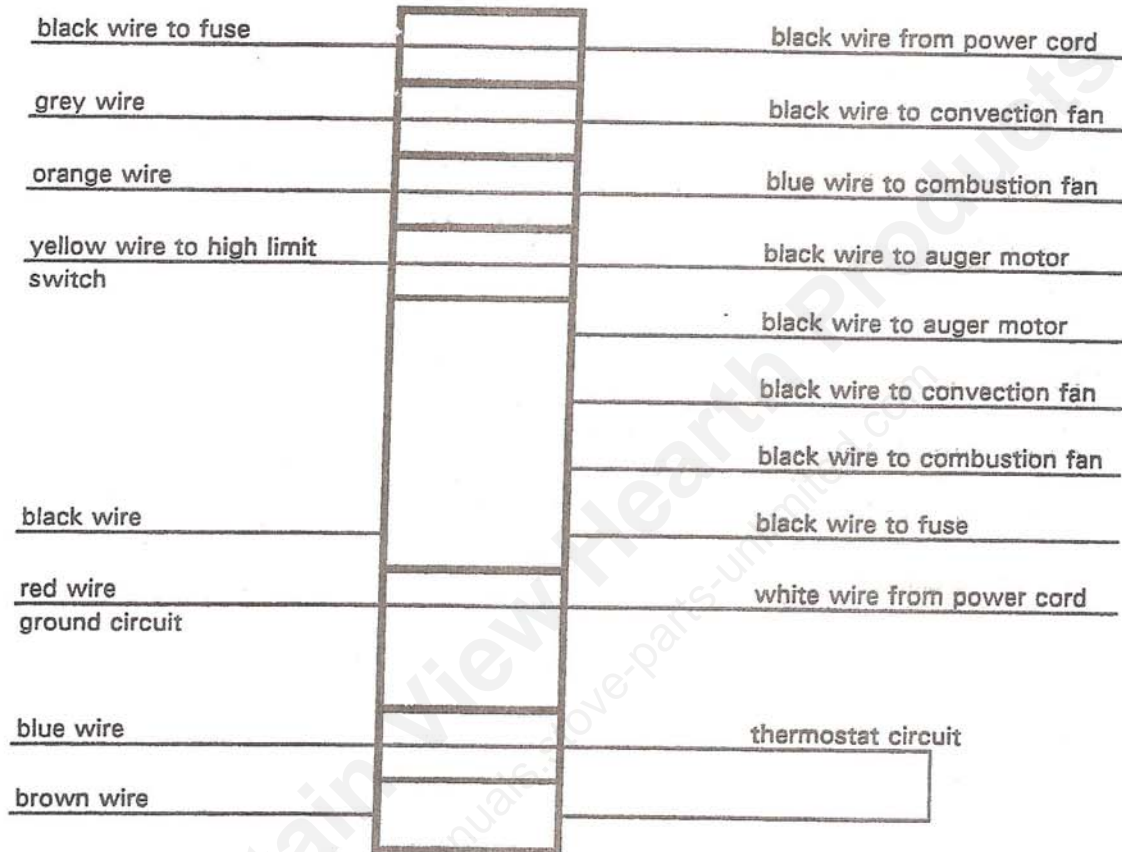

1.7 CIRCUIT BOARD AND EPROM CHIP

The circuit board controls all functions of the stove with input from the low temperature switch, User control board, Hall IC circuit and Air Sensor. The EPROM chip (programmed by ABATEC) is a "read only" memory chip with the stove function program on it. The circuit board runs the program and is compatible with all EPROM versions.

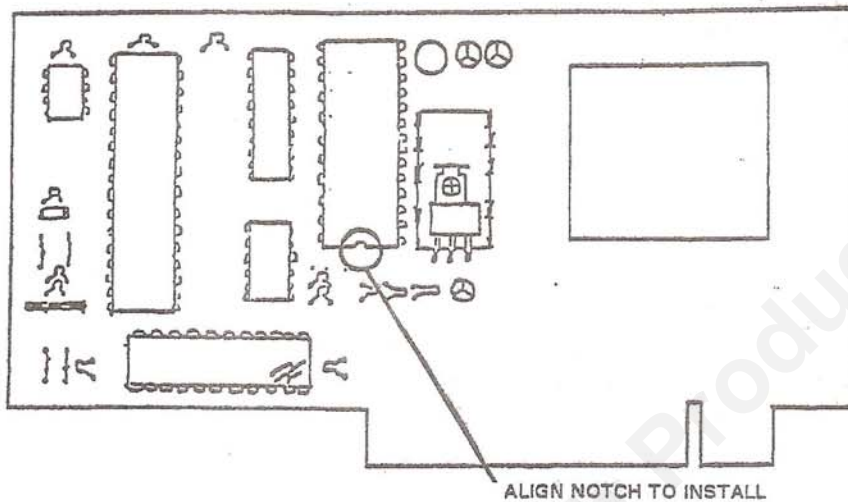

NOTE: It is possible to change only the EPROM chip to improve stove performance. Stove functions are controlled by the Eprom: amount of incoming air, fuel on/off time, start-up program. Any symptom directly related to the Eprom can be corrected by changing the chip.

2.4 Standard Chip

Normal start-up: 12 minutes

2.5A Battery Back-up Chip

Normal start-up: 15 minutes

Convection Fan delay

Operates Battery Back-up System

2.5 Standard Chip w/ Delay

Normal start-up: 15 minutes

Convection Fan delay

3.1 Self Ignitor Chip

Self-ignitor start-up: 16 minutes

Convection Fan delay

Required for Self-ignitor function

Operates Battery Back-up System

CHANGING THE EPROM

To remove the EPROM Chip, pry up evenly and gently on each end of the EPROM until all contact legs are free. The chip lifts straight out of its holder.

Do not discharge static electricity. Respect handling precautions.

To reinstall the EPROM, align all contact legs in the holder and align the notch on the chip toward the center of the board. (Align with the identical notch in the EPROM holder.) When all legs are aligned, press the chip firmly into place.

**ALWAYS CHECK THE VERSION EPROM ON THE STOVE.
KNOWING THE FUNCTION OF THE CHIP CAN PREVENT
UNNECESSARY TROUBLESHOOTING.**

1.8 AIR SENSOR:

The air sensor samples the amount of incoming air and shuts down the auger feed if not enough air is flowing through the stove. The air sensor measures speed, temperature, humidity and density of incoming air and transfers this information to the circuit board. The air sensor adjusts combustion air and auger feed to fine tune air/fuel ratio.

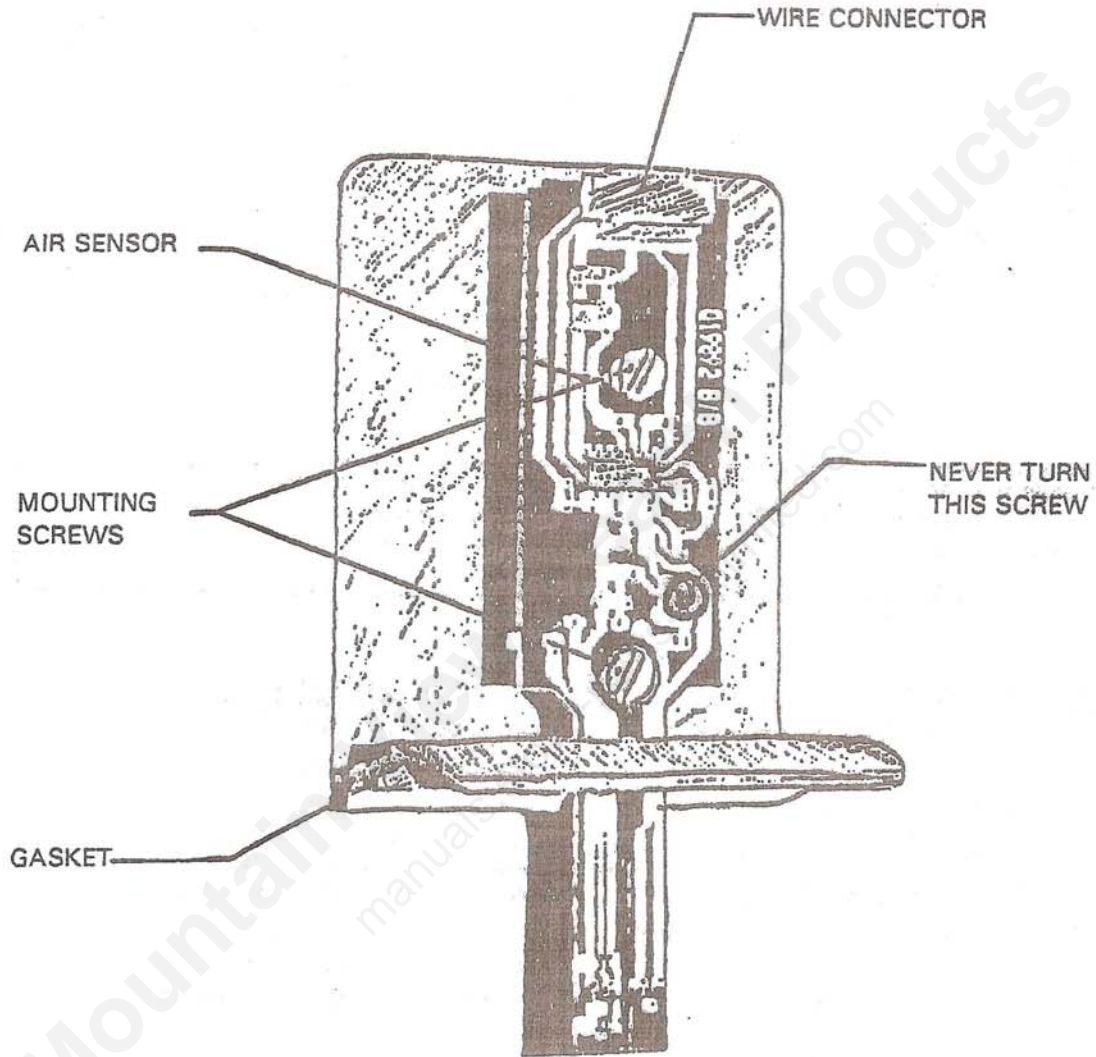

1.9 USER CONTROL BOARD:

The Integra series user control board is the simplest to use in the industry. This board holds the on/off switch, power knob and the main fuse. Adjustments for the air potentiometer and auger potentiometer are made on the user control board. The auger light on the user control board lights whenever power is routed to the auger motor.

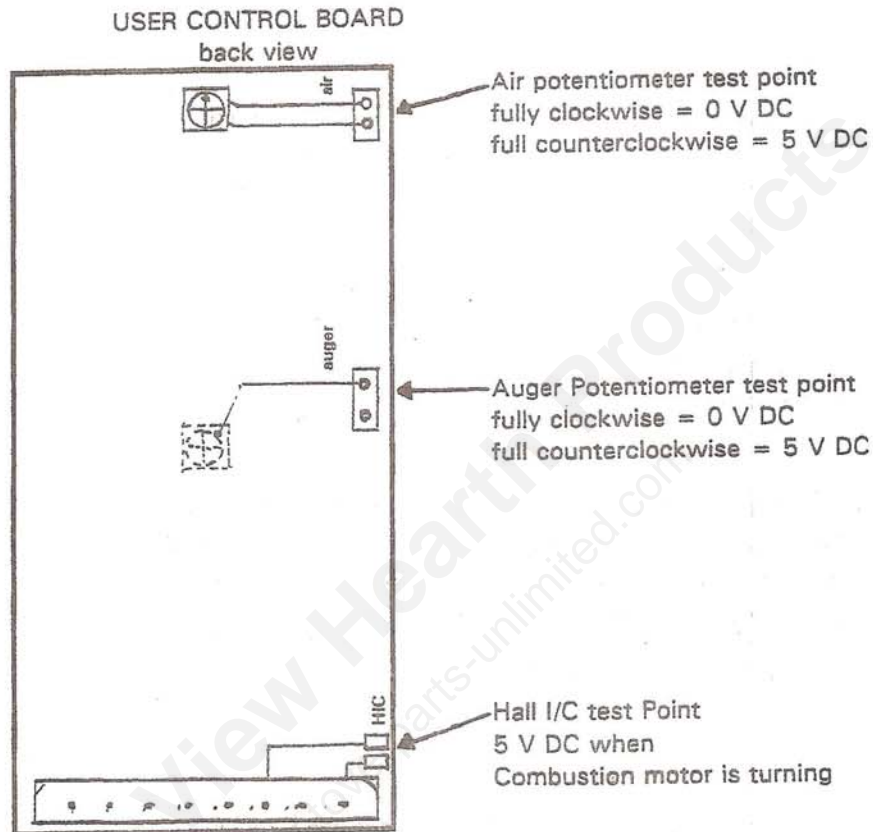

FINE TUNING THE AIR/FUEL RATIO

Fine Tuning of the stove's performance is possible by adjusting combustion motor speed and auger on time. Adjust the potentiometers using a precision type screwdriver. A clockwise adjustment increases the combustion motor speed or the auger on time. A counterclockwise adjustment decreases combustion motor speed or auger on time. Set the potentiometers according to the hash marks on the potentiometer, or adjust and check the setting precisely using a DC Voltmeter at the test points on the back of the user control board. The factory setting is 12 o'clock or 2.5 V DC. Increasing (clockwise) the setting results in a decrease in measurable DC Volts. Decreasing (counterclockwise) the potentiometer results in an increase in DC Volts.

FULLY CLOCKWISE

↓
0 V DC

FULLY COUNTER-
CLOCKWISE

↓
5 V DC

Integra Pellet 9

2. OTHER COMPONENTS:

2.1 STOVE BODY:

The stove body is precision welded of 5mm - 8mm thick sheet metal. Raw materials are laser cut and robot welded for a gas tight, durable frame.

2.2 DOOR AND WINDOW:

The cast iron door and neo - ceram glass resist high temperatures and ensure air tightness between the door frame and stove body. The long handle is easily opened even when the stove is hot.

2.3 TOP FINS AND BOTTOM FINS:

Decorative fins are easily interchanged and available in black or brass finish.

2.4 HEAT EXCHANGE TUBES AND CLEANING RODS:

Manufactured of stainless steel, the heat exchange tubes provide efficient transfer of heat from the combustion air to the room air. The tubes are easily cleaned with the built in cleaners. Access to the tubes is easily obtained by removal of the cast walls for annual service.

2.5 CAST IRON BACK PLATES:

The back plates of the burn area are high quality cast walls that protect the heat exchange tubes and also transmit heat to the heat exchangers.

2.6 ASH PAN AND BURN POT:

The cast iron burn pot is precision machined to allow the maximum amount of air to pass through. The holes are venturi shaped to increase the air velocity as it enters the burn pot. The design of the burn area is very simple and facilitates the weekly cleaning procedure.

2.7 AUGER:

Heavy gauge steel construction and flight all the way to the top of the shaft minimizes the chance of auger jams. The auger inspection plate is a unique Austro - flamm feature that permits easy cleaning of the auger.

2.8 HOPPER AND HOPPER LID:

The extra - large capacity of the hopper provides the longest burn time in the industry. The hopper lid's size makes it very easy to refill.

2.9 SIDE PANELS:

Interchangeable side panels are powdercoated in distinctive colors:

White
Black
Cranberry
Hammered Grey
Blue
Teal
French Bordeaux
Italian Green
Marble White

designer colors:

2.10 SELF-IGNITOR

The INTEGRA Self-Ignitor is an accessory added to the stove for the self-ignition option. The EPROM 3.1 must be used to run the self-ignitor start-up program. Older INTEGRA stoves (with a one-button user board) may be drilled for the self ignitor.

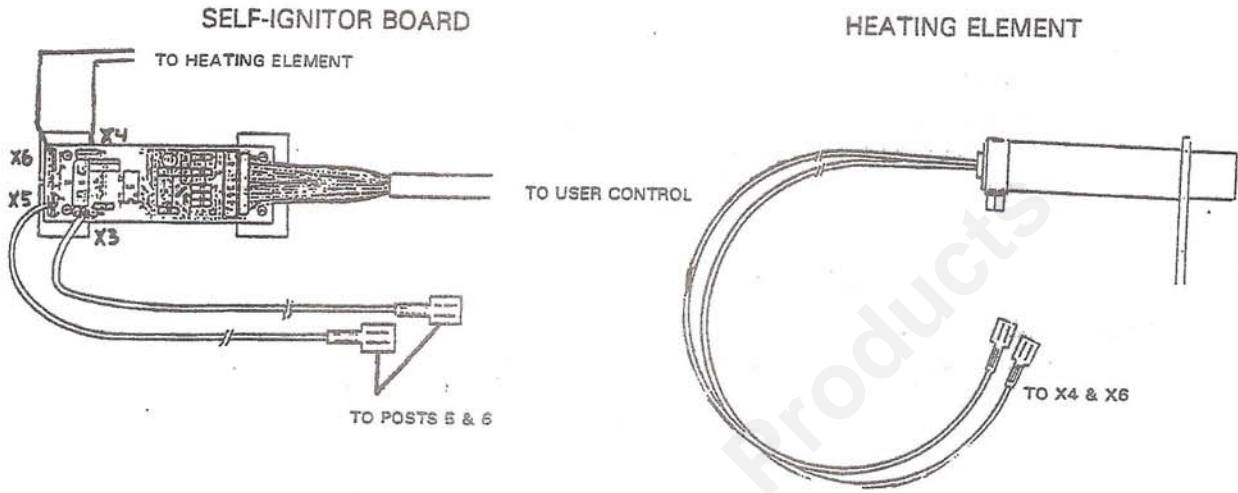

INSTALLATION: predrilled units

When the stove is predrilled and delivered with the 3.1 EPROM installed, remove the cover plate covering the heating element hole. Install the element in position. Route the wires around the stove to the user board area. Connect the self-ignitor board in-line with the user control. Connect power wires from terminals 5 and 6 of the terminal block to connectors X3 and X5 on the self-ignitor circuit board. Connect heating element wires to posts X4 and X6 on the self ignitor board. (See diagram above.)

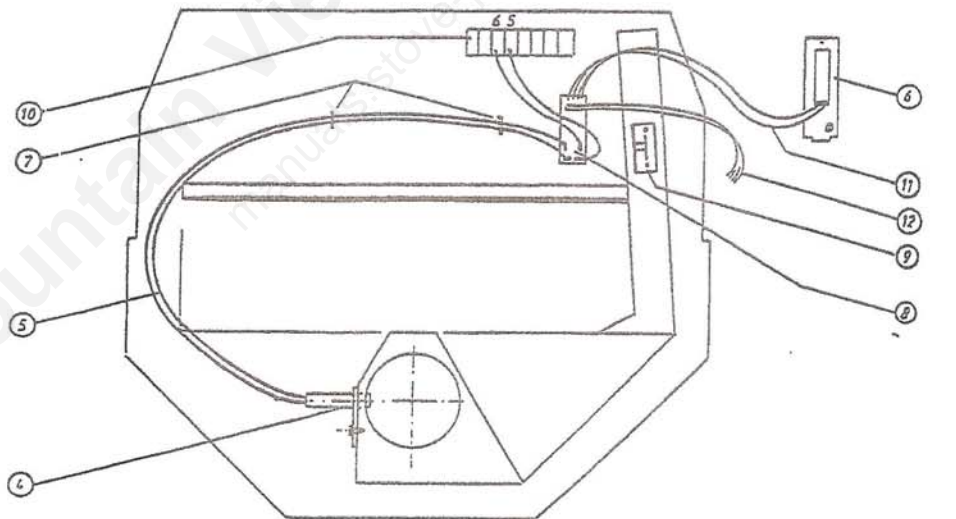

- 1 convection motor
- 2 heating cartridge
- 3 mounting screw
- 4 heating cartridge
- 5 wires from heating cartridge
- 6 user control board

- 7 cable clamps
- 8 self ignitor circuit board
- 9 air sensor
- 10 main terminal block
- 11 quick disconnect from self ignitor circuit board
- 12 quick disconnect from wiring harness

Integra Pellet 12

INSTALLATION: non-drilled units

When the stove is not drilled, the 3/4" heating element hole must be drilled. Use the appropriate drilling jig for the stove.

CALL AUSTROFLAMM WITH SERIAL NUMBER to be sure the correct jig is being used. TWO JIGS ARE AVAILABLE for two distinctly different stove bodies. (See Self-Ignitor Instructions for additional drawings.) Also, the 3.1 EPROM and Ignitor burn pot must be installed.

ANGLED BODY

TOP VIEW

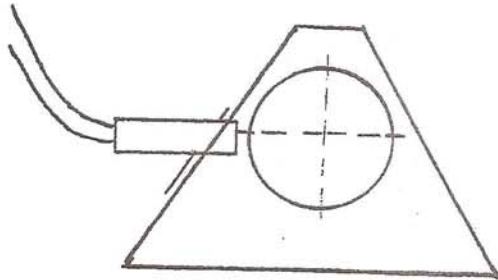

FRONT

STRAIGHT BODY

TOP VIEW

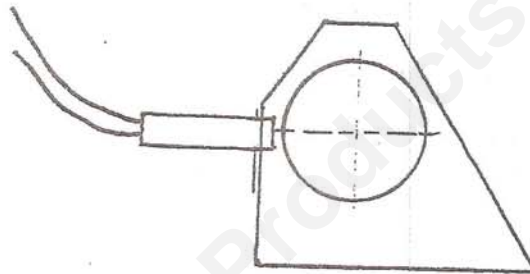

FRONT

DRILLING JIGS

ANGLED BODY

Bolt jig to bottom fin mounting hole

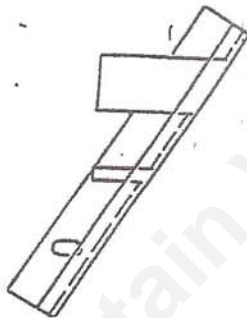

STRAIGHT BODY

Clamp jig in alignment as shown

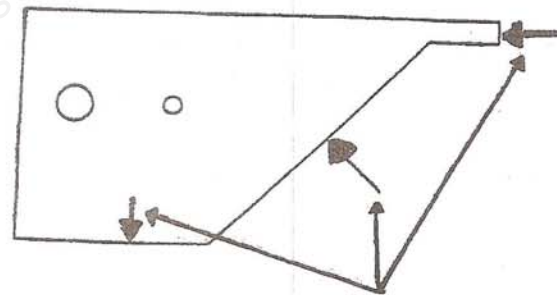

Align with stove body

- DRILLING NOTES**
- > Install jig, then check alignment to make sure resulting hole will be at 90 degrees to burn pot (at 9 o'clock position.)
 - > Drill with a variable speed drill to prevent chatter.
 - > Drill the stove on a bench.
 - > Clean the hole with a round file after drilling.

ALIGNMENT OF THE HEATING ELEMENT AND BURN POT IS CRITICAL FOR PROPER FUNCTION OF THE IGNITOR.

3. FUNCTION OF THE STOVE:

The INTEGRA is computer-controlled. When the stove is plugged in, the circuit board is active. When the switch is turned on, a start-up program begins. During normal operation, the circuit board monitors and adjusts all operating functions. Input from the Air Sensor, Main Potentiometer, Air and Auger Potentiometers, Hall I/C, LT Circuit and On/Off Switch is received by the circuit board.

USER CONTROL The user board adjusts all functions with one power knob. The circuit board determines combustion motor speed and auger on time with additional input from the air and auger potentiometers on the user control board. The HALL I/C signal is also transmitted to the user control board.

RED LIGHT Whenever the electronics produce voltage for the auger motor, the red light illuminates on the user control board. If there is no red light, then the electronics are detecting a drop in air flow and no auger voltage is sent. This is an important troubleshooting tool:

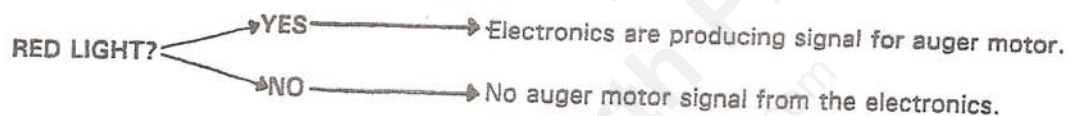

COMBUSTION MOTOR/HALL I/C The circuit board monitors combustion motor speed via the HALL I/C signal. Motor speed is constantly adjusted by the circuit board. When the stove setting is changed, voltage and RPMs (of combustion motor) fluctuate until the proper air value is obtained for the new power knob setting.

AIR SENSOR The air sensor monitors incoming air flow and sends the signal to the circuit board. If the incoming air value is below a required value, then the circuit board makes necessary changes in stove function.

LOW TEMP CIRCUIT The low temperature switch (LT) creates a closed circuit during the initial start-up cycle. The circuit is monitored by the circuit board. If an open circuit occurs (no fuel, malfunction of switch, normal cooling), then the combustion motor runs for 10 minutes and the stove shuts off.

HIGH TEMP CIRCUIT The high temperature switch (HT) is a closed circuit unless overheating occurs. Current to the auger motor flows through the HT.

AIR WASH SYSTEM The cast iron door and door glass are gasketed on all edges except along the top edge. Air is drawn in this gap by the vacuum pressure. As it enters the combustion chamber it travels down since it is relatively cold. As it moves down, it cleans the glass of fly ash. An air tight seal and clean surface assists the air wash.

THERMOSTAT The INTEGRA can operate with a thermostat accessory. A MILLIVOLT THERMOSTAT is required. Follow the thermostat manufacturer's instructions for a millivolt system. Attach the thermostat circuit in place of the jumper wire on posts 7 & 8 on the terminal block. The 2.5, 2.5A and 3.1 EPROMS are specially designed for operation with the thermostat thanks to the convection fan delay feature.

3.1 START UP FUNCTIONS:

When the on / off switch is turned on, the programmed start-up cycle begins. During the start-up cycle, function of the stove is controlled by the information stored on the Eprom chip.

If the switch is turned off, then back on again, the start-up cycle begins again at time = 0 as long as the Low Temperature switch is open.

NOTE:

To Trouble shoot in normal operation, use this feature:
IF THE LT IS CLOSED, THE START-UP CYCLE IS SKIPPED.
 Set power knob to minimum, connect a jumper across the LT, then turn the switch to ON. The stove (within 45 seconds) is at minimum in normal mode.
 (2.4 and 2.5 EPROMS only. 2.5A and 3.1 EPROMS always execute start-up)

EPROM SPECIFICATIONS: START-UP

EPROM 2.4

Time	Function
0-45 sec	Combustion: increasing to 600 RPMs Convection: Off Auger: On: 2.3 sec/ Off 2.3 sec
45 - 90 sec	Combustion 50%, 900 RPMs Auger On: 2.3 sec/ Off 2.3 sec
90 sec	Air Sensor Begins Input to board
90 sec - 5 min	Combustion 50%, 900 RPMs Auger On: 2.3 sec/ Off 2.3 sec
5 - 8 min	Combustion 100%, 1200 RPMs Auger On: 3.9 sec/ Off 0.6 sec
8 min	Combustion Power knob setting Convection ON at Power Knob setting Auger Power knob setting
12-min	LT SWITCH TEST

EPROM 2.5 / 2.5A

Time	Function
time 0-45 sec	Combustion increasing to 600 RPMs Convection Off Auger On: 2.3 sec/ Off 2.3 sec
45 - 90 sec	Combustion 50%, 900 RPMs Auger On: 2.3 sec/ Off 2.3 sec
90 sec	Air Sensor Begins Input to board
90 sec - 10 min	Combustion 50%, 900 RPMs Auger On: 2.3 sec/ Off 2.3 sec
10 min	Combustion 100%, 1200 RPMs Auger On: 3.9 sec/ Off 0.6 sec
12 min	Combustion Power knob setting Convection ON at Power Knob setting Auger Power knob setting
15 min	LT SWITCH TEST

EPROM 3.1

Time	Function
time 0-45 sec	Combustion increasing to 600 RPMs Auger On: 3.9 sec/ Off 0.6 sec Convection Off Heating Element ON, 110 V AC
45 - 90 sec	Combustion min, 600 RPMs Auger On: 3.9 sec/ Off 0.6 sec
90 sec - 3.5 min	Air Sensor Input begins input to board Combustion 100%, 1200 RPMs Auger On: 0.6 sec/ Off: 3.9 sec
7 min	Combustion 50%, 900 RPMs Auger On: 2.3 sec/ Off 2.3 sec
10 min	Combustion 100%, 1200 RPMs Auger On: 3.9 sec/ Off 0.6 sec Heating Element OFF
14 min	Combustion Power knob setting Convection ON at Power Knob setting Auger Power knob setting
16 min	LT SWITCH TEST

LT SWITCH TEST

At this point in the start-up cycle the circuit board checks the LT circuit. It is closed (stove warm) or open (start-up failed.)

LT CLOSED

↓
 NORMAL OPERATION

LT OPEN

↓
 CONVECTION FAN & AUGER OFF
 COMBUSTION MOTOR RUNS 10 MIN
 ↓
 STOVE OFF

3.2 NORMAL OPERATION

The circuit board monitors all functions during normal operation. For any given power knob setting, the air sensor must measure adequate incoming air, and the combustion motor is adjusted to provide the required amount of air. If air is OK, then the signal to the auger motor is generated and the red light blinks. Safety switches monitor exhaust and stove surface temperatures.

DURING NORMAL OPERATION

IF ...	THEN ...
Air sensor detects insufficient air or Hall I/C signal stops or Vacuum is lost	Fuel Feed Shuts Down, NO RED LIGHT Comb. motor goes to maximum
Air or auger potentiometer increased or decreased	Relative comb. motor speed or auger on time increases or decreases.
Main control increased or decreased	All functions increase or decrease.
On/Off switch turned to Off	Fuel feed shuts off. Stove monitors LT circuit. When/if LT opens, conv. fan shuts off. Comb. motor runs 10 mins. longer
LT circuit opens	Fuel feed and conv. fan shut off. Comb. motor runs 10 minutes longer.
High Temperature Switch opens (overheating)	Current flow to auger motor is interrupted, RED LIGHT CONTINUES to cycle.

EPROM SPECIFICATIONS: NORMAL OPERATION

EPROM 2.4

	Combustion	Auger	Convection
min	1.2 m/s	0.9 sec	700 rpm
max	3.0 m/s	3.6 sec	1800 rpm

EPROM 2.5 / 2.5A

	Combustion	Auger	Convection
min	1.5 m/s	0.9 sec	900 rpm
max	3.0 m/s	3.6 sec	2000 rpm

EPROM 3.1

	Combustion	Auger	Convection
min	1.5 m/s	0.9 sec	900 rpm
max	3.1 m/s	3.6 sec	2000 rpm

VOLTAGES

	EPROM 2.4	
min	Combustion	38 V
	Convection	58 V
max	Combustion	50 V
	Convection	90 V

	EPROM 2.5 (2.5A)	
min	Combustion	40 V
	Convection	60 V
max	Combustion	52 V
	Convection	95 V

	EPROM 3.1	
min	Combustion	40 V
	Convection	60 V
max	Combustion	52 V
	Convection	95 V

Measure all voltages with 10% margin of error. Use AC Voltmeter on both leads to the motor.

3.3 SHUT DOWN CYCLE

The shut down cycle ensures that no unburnt pellets remain and no exhaust gas is left in the system before all motors stop. There are two ways to initiate the shut down cycle: turn the switch off or deplete the fuel supply

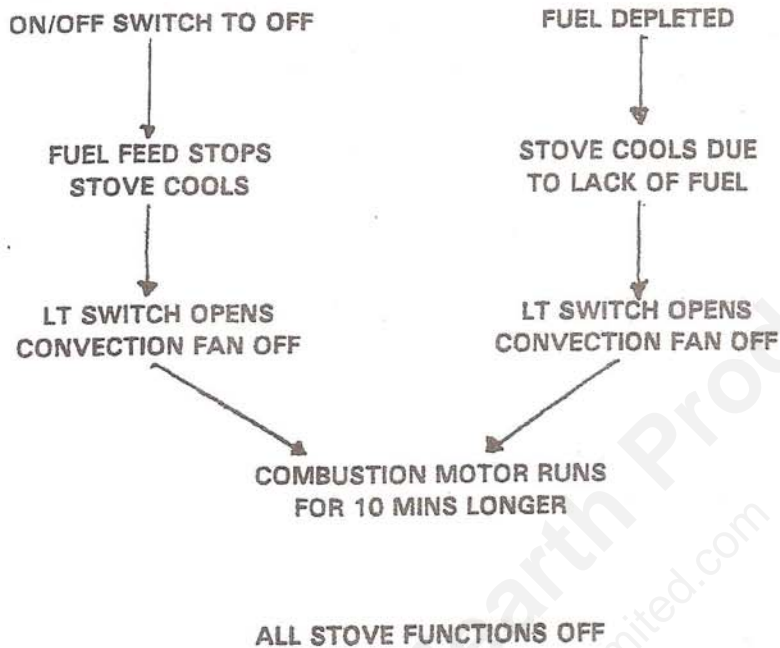

3.4 SAFETY FEATURES

The INTEGRA is fuse protected by a 2 A, 250 V Slow Blow fuse. All components are protected by this fuse. The combustion motor is also capacitor protected to extend the life of the motor.

Adding a surge protector to the stove is a simple way to further protect the stove's components. A 3 Amp power strip with surge protection or Austroflamm's in-line surge protector is acceptable.

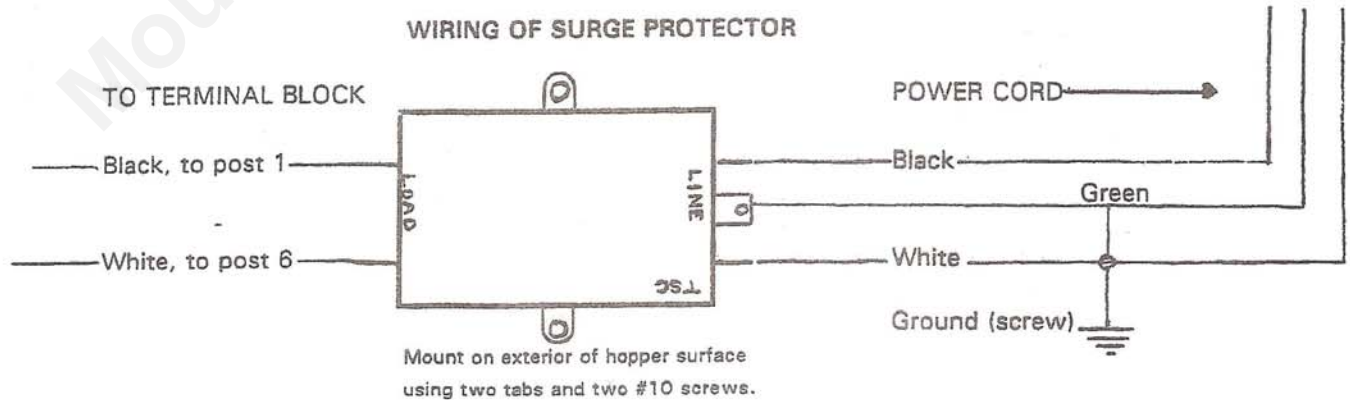

3.5 SELF-IGNITOR OPERATION

When using the self-ignitor, the 3.1 EPROM start-up program is followed. Refer to the EPROM SPECIFICATIONS for details on the start-up cycle.

The burn pot must be clean in order for the heat from the element to be transferred to the new pellets. Key points in the start-up cycle are listed below.

Start to 3 minutes

- > Heating element gets 110 VAC from start. Element starts to glow within 45 seconds.
- > Combustion motor runs at minimum setting
- > Auger on for 3.9 seconds: filling burnpot

3 to 6 minutes

- > Combustion motor runs at maximum setting. Heat is drawn across element into burnpot. **ALIGNMENT IS CRITICAL.**
- > Auger switches to minimum. Allows fuel in burnpot to ignite.
- > Heating element glowing brightly, igniting pellets.

6 Minutes

- > Combustion motor and auger switch to 50% setting
- > Heating element glowing brightly, igniting pellets.

10 Minutes

- > Combustion motor and auger switch to 100%
- > Heating element OFF

14 Minutes

- > Convection Fan ON
- > All functions run at power knob setting

16 Minutes

- > LT Switch test: start-up cycle over

SELF-IGNITOR CIRCUIT BOARD

The circuit board uses a timing sequence to send voltage to the element. If no voltage is produced and all connections are made, the ignitor board may be at fault.

HEATING ELEMENT

The heating element is a 110 V AC component. From the time the start button is turned ON until 10 minutes into start up, the element gets 110 V AC through the self ignitor circuit board. Verify this voltage to the element to troubleshoot. A resistance reading of the element can test for shorts. OHMs through the element should be 65 Ohms (+/- 10%) If resistance is very low, the element may not glow hot enough.

4. BURNING AND INSTALLATION OF THE STOVE

4.1 EXHAUST SYSTEM:

- > Use non combustible floor protection
- > Use a listed pellet pipe with a 3" or 4" diameter

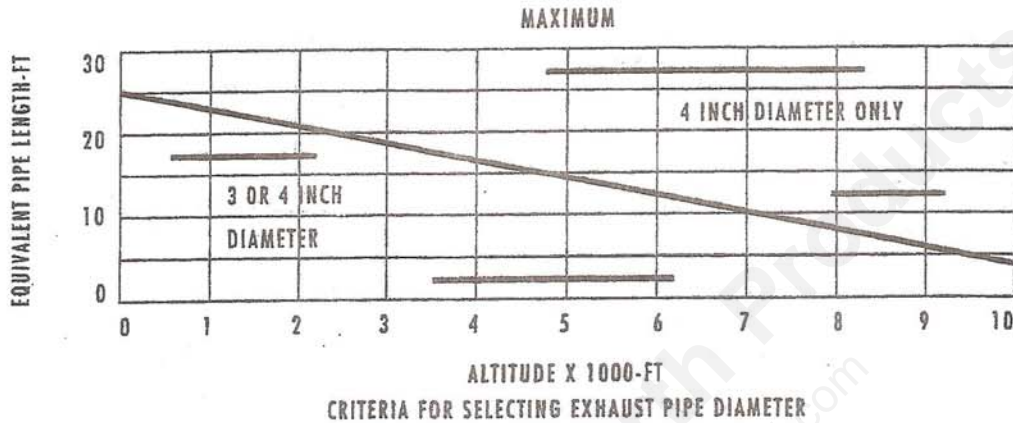

- > Horizontal straight length = 1 x actual length ft.
- > Vertical straight length = 0.5 x actual length ft.
- > 90° elbow or tee = 5 ft.
- > 45° elbow = 3 ft.

NOTE:

Total number of feet in the system must not exceed 30 feet using this formula.

4.2 VENTING INTO AN EXISTING CHIMNEY:

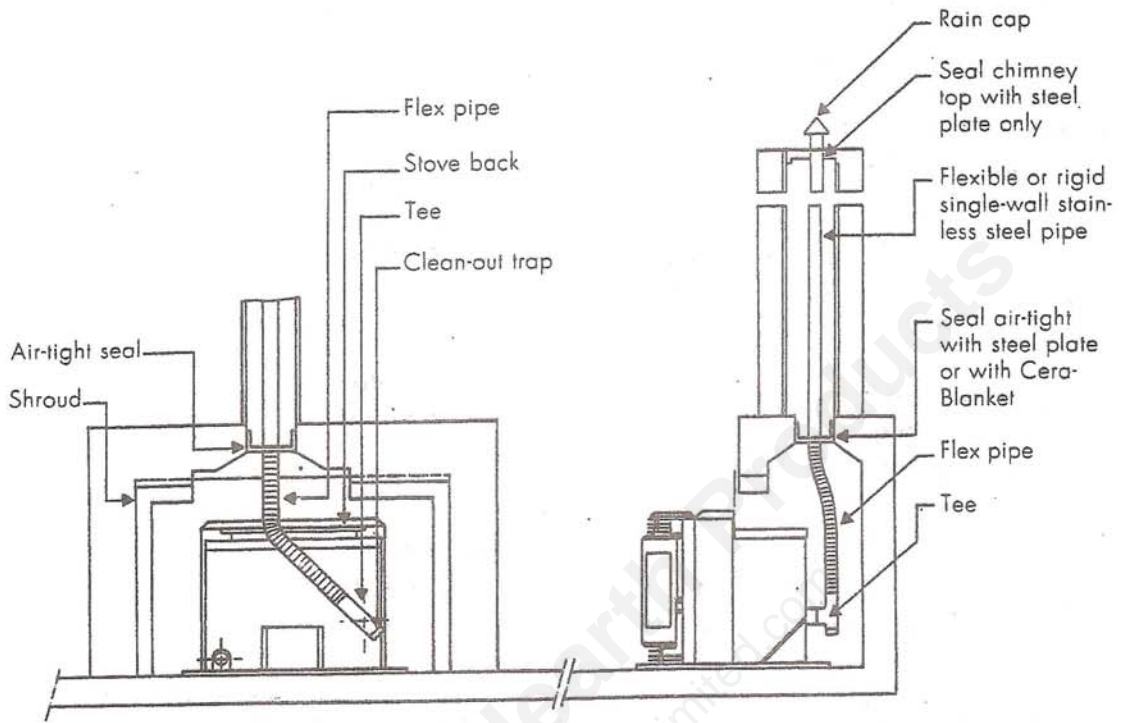

4.3 INSTALLATION INTO COMBUSTIBLE FRAMEWORK

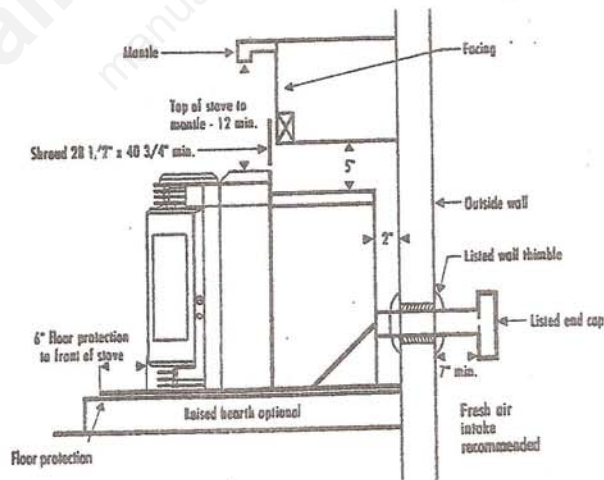

4.4 INSTALLATION FREESTANDING:

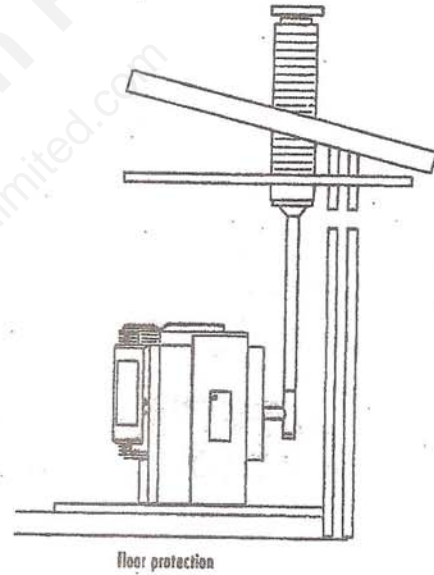
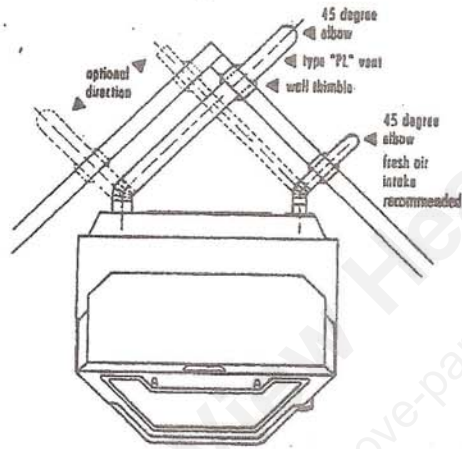
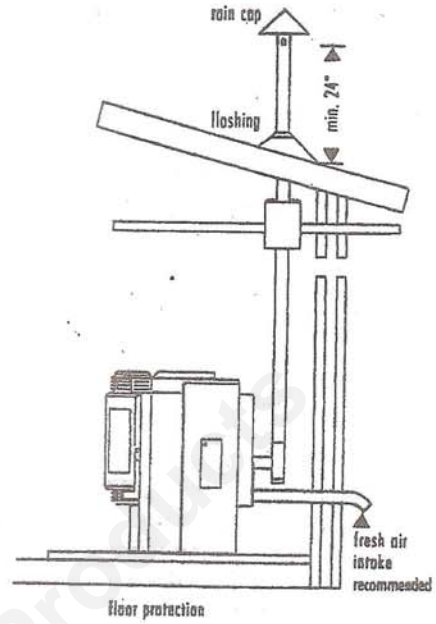
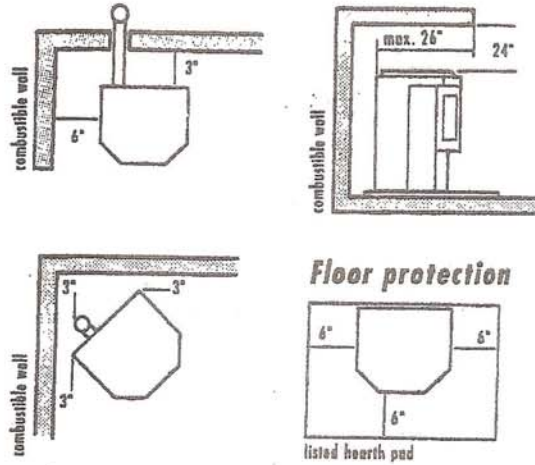

4.5 OUTSIDE AIR CONNECTION:

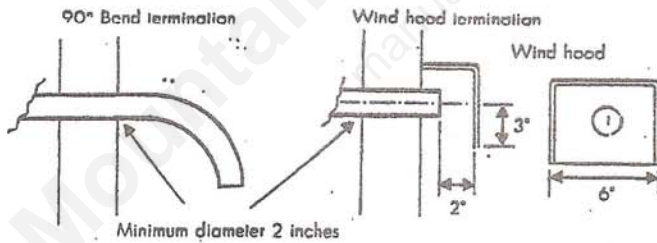

NOTE:

Blockage, excessive length or bends in the air intake pipe starve the stove from combustion air.

NOTE:

All the installation is a suggestion and recommended by Austroflamm.

5. PREBURN PROCEDURES:

- 5.1 Check shipping carton for any external damage caused by shipping. If container damage is present make thorough inspection of stove for damage. If any damage is present, document damage and file reclamation claim against shipper.

NOTE:

Austroflam is not responsible for shipping damage and cannot initiate claim.

- 5.2 Check stove to make sure all components are present.
- 5.3 Check bottom of hopper to make sure there is no foreign material that could jam auger.
- 5.4 Check for proper electrical connections.
- 5.5 Install internal circuit board (on the insert user control board and internal circuit board) and connect power cord to 120 Volts grounded receptacle. Turn the stove on and let it run one cold cycle (about 25 minutes). Place about 10 lbs of pellets in the hopper. Auger will prime itself. After 25 minutes stove will shut down automatically.
- 5.6 Set power knob to maximum setting.
- 5.7 Sequence to start the fire can vary, this is only one method. Place small handful of alcohol impregnated pellets (or pellets mixed with a burning gel) in the burn pot, turn on / off switch to on for a second then off, light pellets , close door, allow fire to establish itself then turn switch back to the on position.

NOTE:

Turning the switch on then off allows only the combustion motor to operate, preventing excess pellets from smothering the fire.

- 5.8 12 (8) minutes into start - up cycle the convection fan will come on.

- 5.9 Let stove burn for approximately 60 minutes. After the first 20 minutes open and close door every 10 minutes to make sure door gasket doesn't stick to curing paint.
- 5.10 After the first 60 minutes, turn the power knob to minimum setting and allow to burn at this level for 30 minutes to ensure that the stove will maintain a minimal fire.
- 5.11 After the 30 minute low fire test, reset power knob to maximum setting and allow stove to burn on high for an additional 30 min.
- 5.12 Turn stove off (auger stops feeding) and check to make sure that after the low limit opens (convection fan shuts down) combustion motor continues for an additional 10 minutes.
- 5.13 You now have a product that you can install with confidence that will function correctly, provided you have properly instructed customer to the operational and maintenance procedures.

NOTE:

Dealers that preburn stoves find 90% of warranty failures during the preburn procedure. It's a lot easier to correct these problems in your shop where you don't have to fight the installation or an irate customer. It's also more economical to make warranty repairs in your shop rather than in the customer's house.

6. MAINTENANCE SCHEDULES:

6.1 BURN POT:

Clean as needed, 2 to 7 times a week, depending on characteristics of pellet fuel used and operational habits of stove owner.

6.2 ASH PAN:

Clean as needed, visually apparent.

6.3 DOOR GLASS:

Clean as needed, usually daily, can be more or less frequent depending on characteristics of pellet fuel used and operational habits of stove owner.

6.4 HEAT EXCHANGE RODS:

Clean 1 or 2 times a day.

6.5 LOWER CAST PANEL:

Remove and clean heat exchange area every ton of pellets, more frequently if using a fuel with a high ash content.

NOTE:

Not doing this procedure can cause auger not to operate, because of restricted air flow.

6.6 HOPPER:

Let hopper run almost empty and vacuum sawdust from sides and contours. Do this monthly if dumping pellets directly from the bag into the hopper. (If customer uses a pellet dispenser that removes sawdust as it dispenses, do this procedure at time of annual service)

6.7 ANNUAL SERVICE:

Remove combustion motor from the cast aluminium housing; clean impeller and housing area. Remove access plate from rear exhaust chamber and vacuum out all ash. Remove both lower and upper cast panels and clean heat exchange tubes. Clean all vent piping, remove convection motor and clean impeller. Remove air sensor and clean with approved solvent (example: Radio Shack aerosol degreaser). Clean hopper and auger pathway, clean dirt and dust from all rear areas of the stove, particularly auger motor and areas close to circuitry

6.8 PROCEDURES FOR CLEANING:

Note:

This procedure will require gaining access to the front and sides of the unit with enough room to move freely. If working on a freestanding model, all side panels will need to be removed.

This procedure can be simplified if you arrive with the appropriate tools and materials. Having these items on hand can expedite the procedure. These may consist of the following:

- 1 High temperature anti-seize compound
- 2 6mm hex key wrench
- 3 Phillips screwdriver
- 4 Flashlight
- 5 Ash vacuum
- 6 Metric ratchet set
- 7 Small soft bristled brush
- 8 Flat tip screwdriver
- 9 Pipe cleaning brush for 2" pipe
- 10 Combustion motor gasket material

First, gain access to the burn area by opening the door and remove any ash or pellets from the burn pot and ash pan. Remove the ash pan and burn pot and place them aside.

Using your 6mm hex key wrench or 10mm socket (for older model) remove the bolts which secure the lower cast wall. The wall should simply fall out and away from the body of the stove. Brush off any ash build-up and set the lower cast wall aside. The same wrench should work as to remove the two bolts holding the upper cast wall. Support should be given as the bolts are removed, since this plate will tend to fall. Once the bolts are removed the bottom of the cast plate should be pulled down and away from the unit. Brush off any residue and set the upper cast wall aside.

You should now have access to the entire heat exchange system. Vacuum out any ash which may have built up in this area. The soft brush and flat tipped screwdriver can be used to clean around and in between the tubes. Carefully brush the uppermost interior of the burn area using the flashlight to determine if grooves on the underside of the cast hood are clear of obstructions which may limit airflow.

On the right side of the stove, remove the two screws which support the circuit board and its chassis. You should now be able to see a small rectangular access plate secured by four screws. Removal of the access plate will give access to the internal combustion chamber. Thoroughly vacuum out all ash build-up using the pipe brush to reach the sides and corners. Special attention should be paid to the small orifice holes which are located directly behind each heat exchange tube and penetrate the forward most wall of the combustion chamber to ensure that they are clear of obstructions. You can determine this by placing a flashlight inside the chamber and stepping in front of the stove. The holes should now be visible.

On the left side of the stove, the combustion motor should be removed from its housing and the blades should be wiped clean. Also, remove the low limit switch and brush it off to prevent premature shut downs. Once completed, regasket the motor and the low limit switch and reinstall.

Of utmost importance before closing up the stove is to place a generous coating of anti-seize compound to all bolts and nuts which are exposed to heat. Once accomplished you are ready to reinstall the back access cover and the upper and lower cast walls. Applying touch up paint to the burn area can leave the stove looking like new.

You may wish to check the hopper to determine if the auger has accumulated fines. This is an easy way to prevent future call backs and takes just a few moments. If you find a build-up of fines, vacuum out what you can. If the problem is serious you may need to remove the shaft and clean out the residue from the back side of the unit.

Providing this service a minimum of every two tons will maintain proper combustion, prevent future service requirements, and extend the life of the stove. Many times the customer will observe the procedure and perform it themselves. This procedure will protect a valuable investment the client has made in your company. It is in your best interest to let them know it was a good investment.

OPERATIONAL TESTS

The following test procedure will allow checking of individual functions which may be at fault. Each test sequence is preceded with bypassing the start-up cycle. Operational tests prescribed below are begun at the lowest setting in normal operation.

CONVECTION FAN

- 1 Set switch to OFF, power knob to minimum
- 2 Connect a jumper wire across the LT
- 3 Plug stove in, convection fan and combustion motor start
- 4 Turn switch to ON
- 5 Measure voltage going to convection fan
MINIMUM 60 VAC +/- 10%
- 6 Turn power knob to maximum
- 7 Measure voltage going to convection fan
MAXIMUM 95 VAC +/- 10%

Measure voltage between the two leads to the convection fan (posts 2 & 5.)

If voltage is OK, but fan does not operate:

Check fan direct to power. If it will not run on 110 VAC, the fan is defective.
Check wiring to fan for any breaks or pinching.

If voltage is greater than maximum (110 V AC):

Main Circuit Board is defective

If voltage is less than minimum or zero:

Measure DC voltage going from LT switch to board
It must be minimum 1 V DC

If voltage is 1 V DC or greater then the main board is defective

If voltage is below 1 V DC, then there is a wiring or connection problem on the LT circuit.

COMBUSTION MOTOR

- 1 Set switch to OFF, power knob to minimum
- 2 Connect a jumper wire across the LT
- 3 Plug stove in, convection fan and combustion motor start
- 4 Turn switch to ON, wait 45 seconds
- 5 Measure voltage going to combustion motor
MINIMUM 40 VAC +/- 10%
- 6 Turn power knob to maximum
- 7 Wait 45 seconds (for motor to fully change settings.)
- 8 Measure voltage going to combustion motor
MAXIMUM 52 VAC +/- 10%
- 9 Open the door, allow air sensor to shut off fuel and speed up combustion motor.
If the fuel continues and combustion motor does not change then the air sensor is defective.
- 10 Measure voltage to motor with door open and combustion motor at full speed.
VOLTAGE 100 VAC +/- 10%
If voltage is always 0 VAC, then the circuit board or wiring to the motor is defective.
- 11 Close door, motor returns to power knob setting.
If motor does not return to low setting (40 V), circuit board or air sensor is defective.
If voltage is always too high (90 VAC and higher) and motor will not turn, then the motor may be defective.

Measure voltage between the two leads to the combustion motor (posts 3 & 5.)

Integra Pellet 27a

OPERATIONAL TESTS

The following test procedure will allow checking of individual functions which may be at fault. Each test sequence is preceded with bypassing the start-up cycle. Operational tests prescribed below are begun at the lowest setting in normal operation.

CONVECTION FAN

- 1 Set switch to OFF, power knob to minimum
- 2 Connect a jumper wire across the LT
- 3 Plug stove in, convection fan and combustion motor start
- 4 Turn switch to ON

- 5 Measure voltage going to convection fan
MINIMUM 80 VAC +/- 10%

Measure voltage between the two leads to the convection fan (posts 2 & 5.)

- 6 Turn power knob to maximum
- 7 Measure voltage going to convection fan
MAXIMUM 95 VAC +/- 10%

If voltage is OK, but fan does not operate:

Check fan direct to power. If it will not run on 110 VAC, the fan is defective.
Check wiring to fan for any breaks or pinching.

If voltage is greater than maximum (110 V AC):

Main Circuit Board is defective

If voltage is less than minimum or zero:

Measure DC voltage going from LT switch to board
It must be minimum 1 V DC

If voltage is 1 V DC or greater then the main board is defective

If voltage is below 1 V DC, then there is a wiring or connection problem on the LT circuit.

COMBUSTION MOTOR

- 1 Set switch to OFF, power knob to minimum
- 2 Connect a jumper wire across the LT
- 3 Plug stove in, convection fan and combustion motor start
- 4 Turn switch to ON, wait 45 seconds

- 5 Measure voltage going to combustion motor
MINIMUM 40 VAC +/- 10%

Measure voltage between the two leads to the combustion motor (posts 3 & 5.)

- 6 Turn power knob to maximum
- 7 Wait 45 seconds (for motor to fully change settings.)
- 8 Measure voltage going to combustion motor
MAXIMUM 52 VAC +/- 10%
- 9 Open the door, allow air sensor to shut off fuel and speed up combustion motor.
If the fuel continues and combustion motor does not change then the air sensor is defective.
- 10 Measure voltage to motor with door open and combustion motor at full speed.
VOLTAGE 100 VAC +/- 10%

- If voltage is always 0 VAC, then the circuit board or wiring to the motor is defective.

- 11 Close door, motor returns to power knob setting.
If motor does not return to low setting (40 V), circuit board or air sensor is defective.

If voltage is always too high (90 VAC and higher) and motor will not turn, then the motor may be defective.

Integra Pellet 28

7.2 STOVE WILL NOT TURN ON:

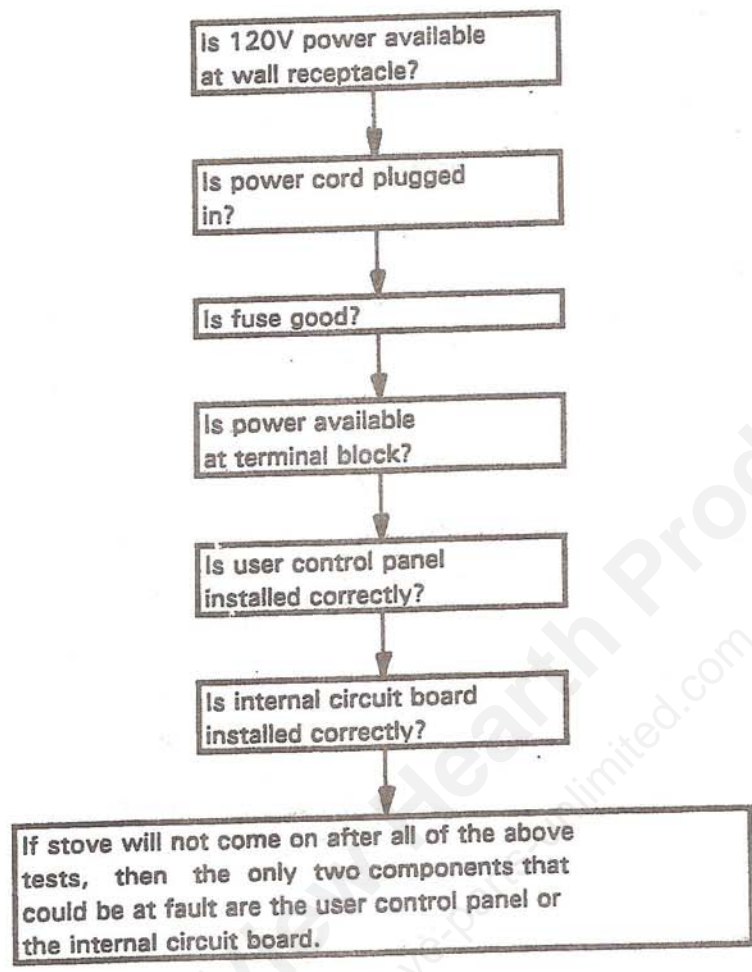

NOTE:

Make sure combustion motor impeller blades are free (spin test). If motor will turn by hand but won't turn on, then proceed with trouble shooting procedures.

NOTE:

If stove shuts down, no matter at what time or setting, check low limit switch and high limit switch or wires to these two switches first. If the two switches and the wires are OK, go to regular trouble shooting.

7.3 STOVE SHUTS OFF:

> AFTER START UP:

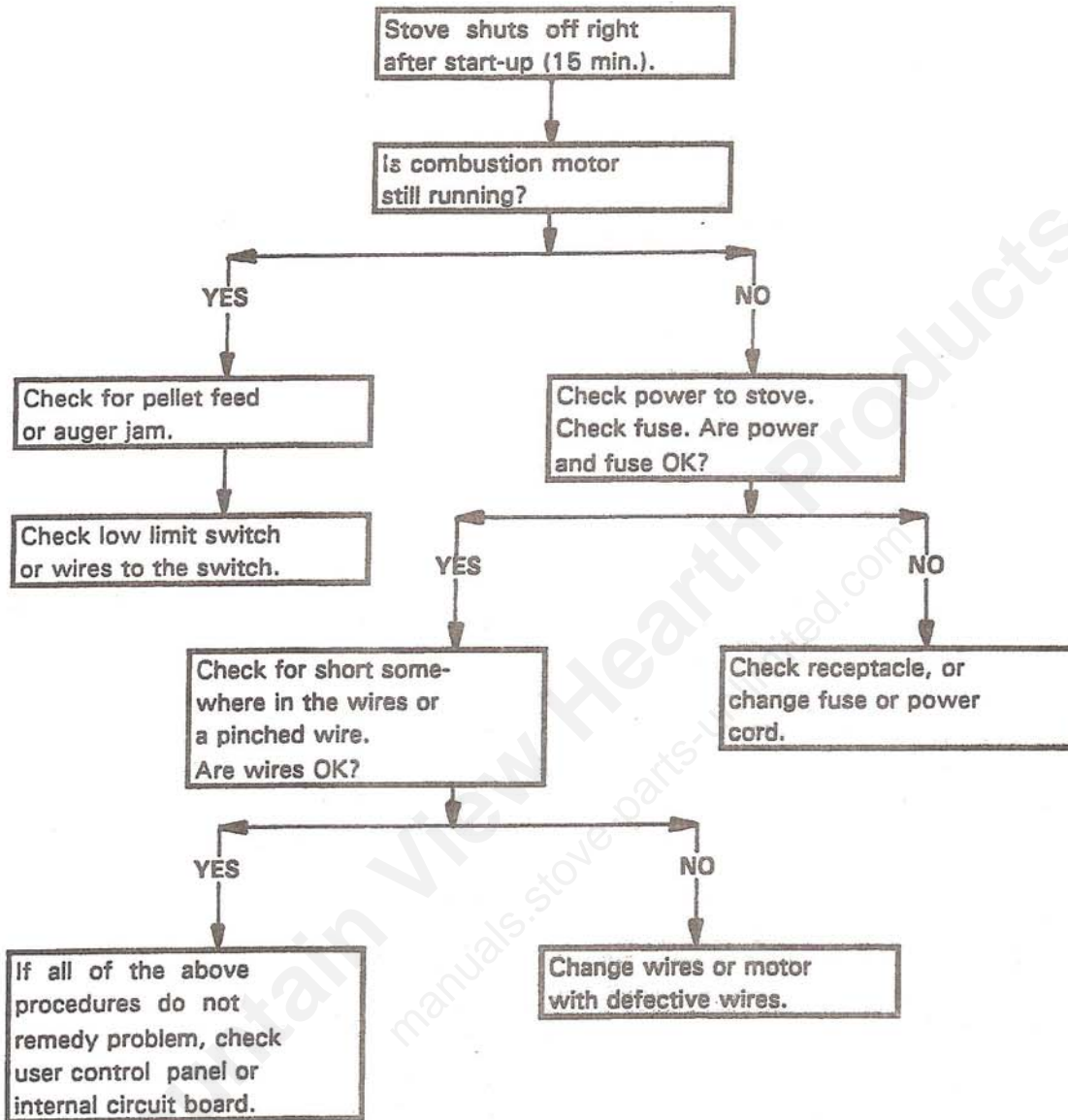

> at any setting:

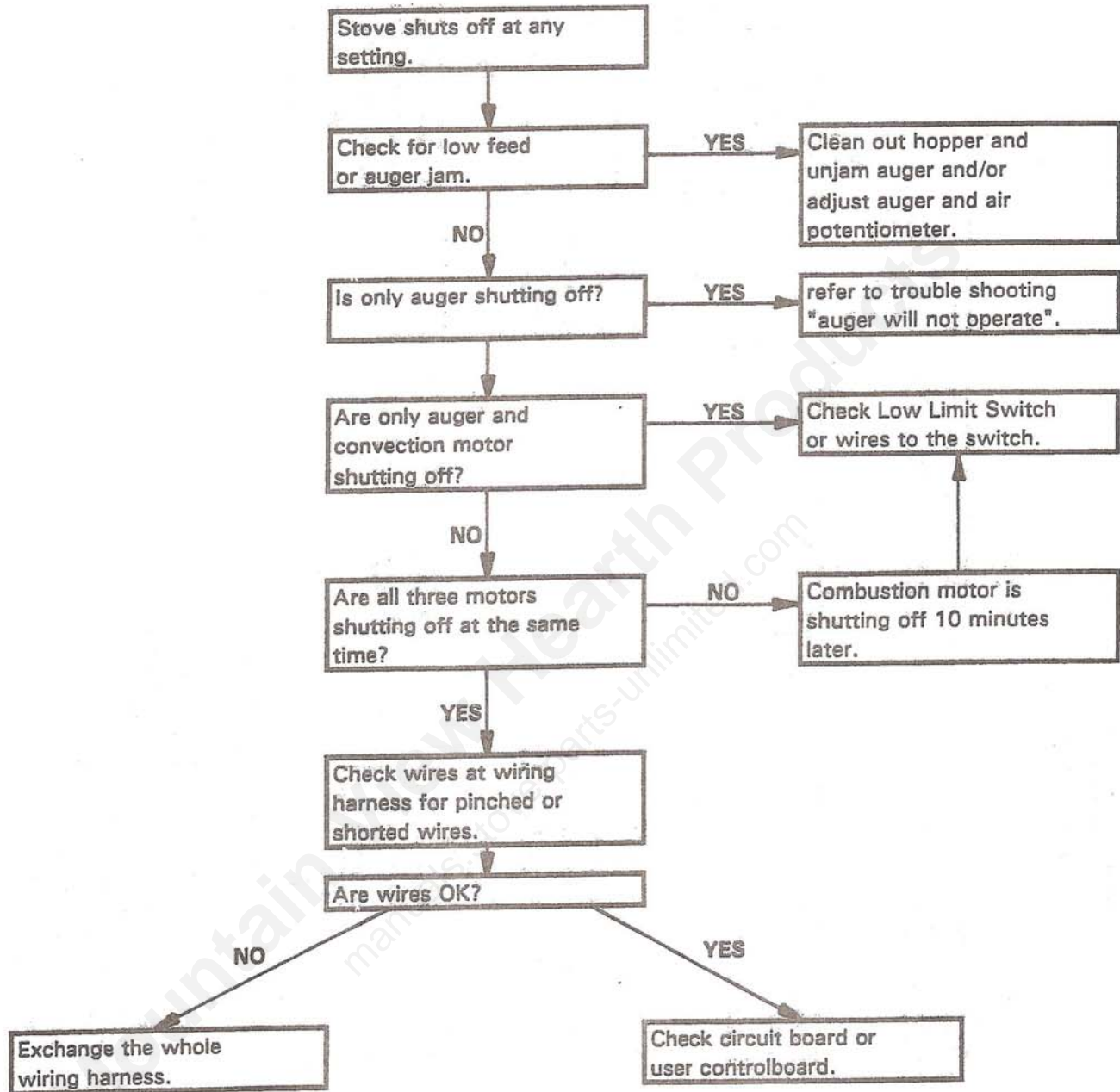

> by itself:

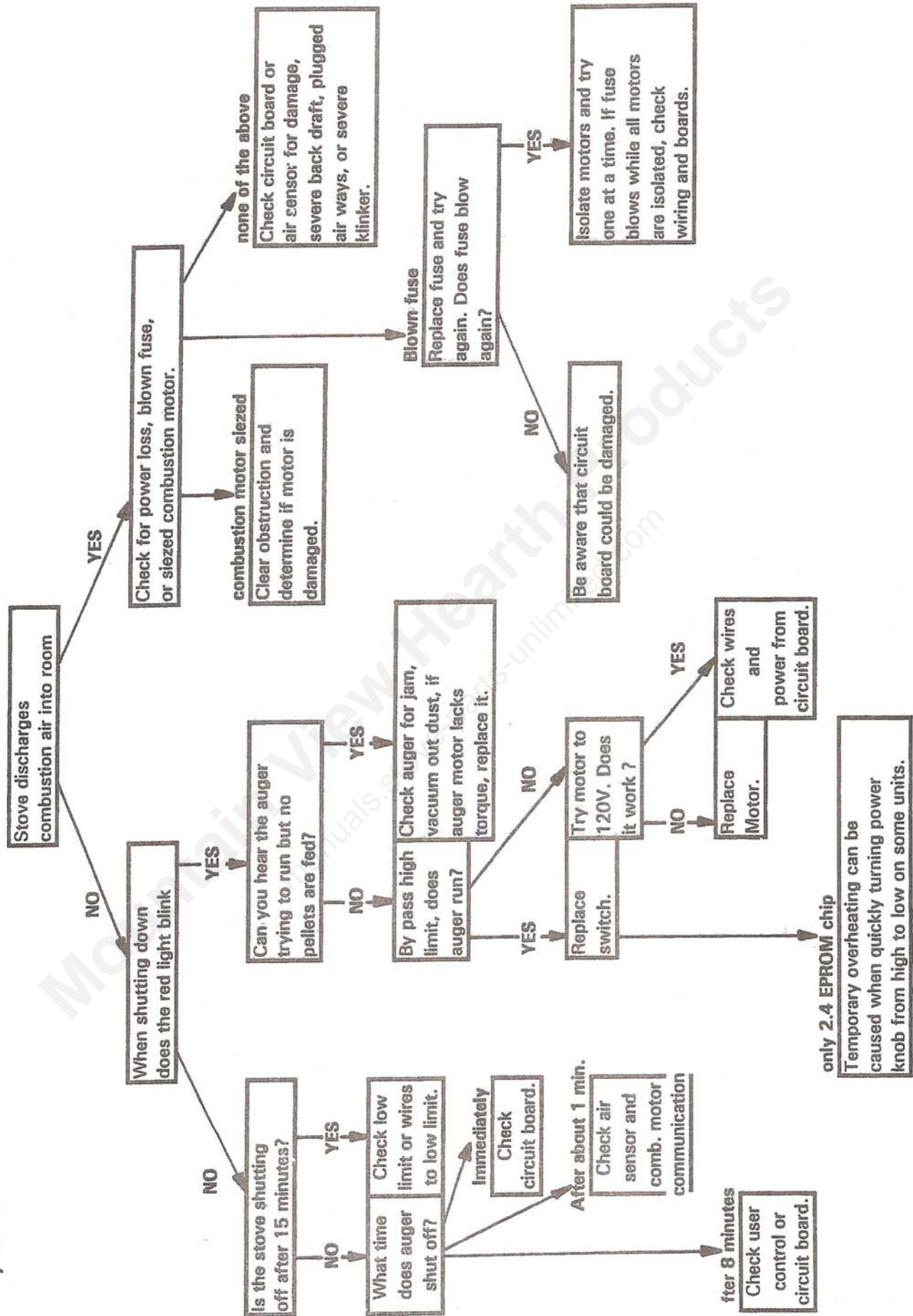

> ON A LOW SETTING:

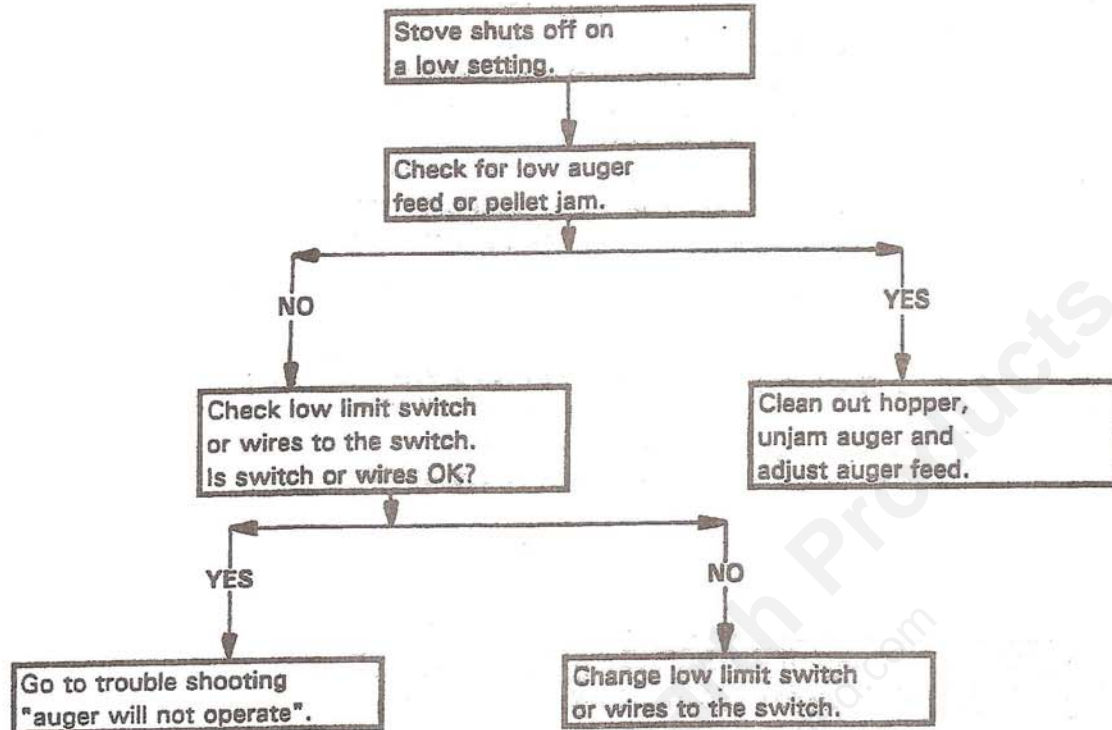

7.4 SPECIFIC SYMPTOMS:

Fuse blows: > when stove is initially plugged in: check for dead short in wiring leading to the motors or the motors themselves, replace faulty motor.

> with on/off switch turned on, check motor for excessive current draw, auger: 0.55 Amps

combustion motor: 0.31 Amps

convection motor: 1.1 Amps

If all motors check out OK, replace either user control panel or internal circuit board.

NOTE: Replace fuse and reset. If fuse blows again, determine one elapsed before it shorts. If immediate, isolate motors and dry again. Install motors individually and test. If fuse blows while all motors are disconnected check control board, circuit board, air sensor and wiring harness.

Bad low limit switch:

- > Stove starts, runs for 15 minutes then auger motor and convection motor stops, but combustion motor continues for 10 minutes.
- > Stove stays on even when cold.
- > Stove starts in operational mode (all motors running) when plugged in even when on/off switch is in the off position.
- > Stove runs on low for a while, then auger and convection motor quit but combustion motor runs for 10 more minutes. (This symptom can also be caused by a low pellet feed setting.)

Faulty air sensor:

- > Combustion motor just barely turns, auger won't come on, red light is not blinking.
- > Auger starts, cycles a few times then quits.
- > Auger quits, then combustion motor speeds up.
- > Auger runs for a while then stops, then starts then stops (very erratic).

NOTE:

These symptoms could also be caused by a faulty Hall IC circuit (replace combustion fan).

Any motor comes on runs full speed when stove is first connected to power source and on/off switch is in the off position, check for short in wire between affected motor and the internal circuit board.

Combustion motor will not turn with operational voltage but runs OK when given full 120 Volts. Replace motor.

Convection motor shuts down (any time after start - up), but other motors continue to run. Check for blockage in fan, let motor run on direct 120 Volts out of the receptacle, see if motor gets too hot while operating in stove.

Check user control board or internal circuit board if:

- > there is no control over stove.
- > the auger continues to feed, even if the stove is shut off.
- > there is no control over pellet feed.
- > convection motor starts when you first start the stove.

8. DIFFERENT READINGS:

8.1 INFORMATION ABOUT EXHAUST TEMPERATURE, CO AND CO₂ :

	Power knob setting	
	minimum	maximum
Exhaust temp	194° F - 212° F	392° F - 428° F
CO	200 ppm	100 ppm
CO ₂	8%	3%

8.2 VACUUM IN COMBUSTION CHAMBER:

Knob setting	Stove operation in "WC	
	cold	hot
min	0.01	0.06
max	0.1	0.17

Measure vacuum pressure at the test point on the lower right corner of the combustion chamber. Remove the 10mm bolt, and attach the guage at this point.

8.3 RPM READING ON THE MOTORS: (measured on a cold stove)

Knob setting	combustion motor	convection motor
min	600 RPMs	800 - 1000 RPMs
max	1250 RPMs	1850-2000 RPMs

9. SCHEMATICS OF THE STOVE

MAINS CONNECTION
110 VOLTS 60Hz

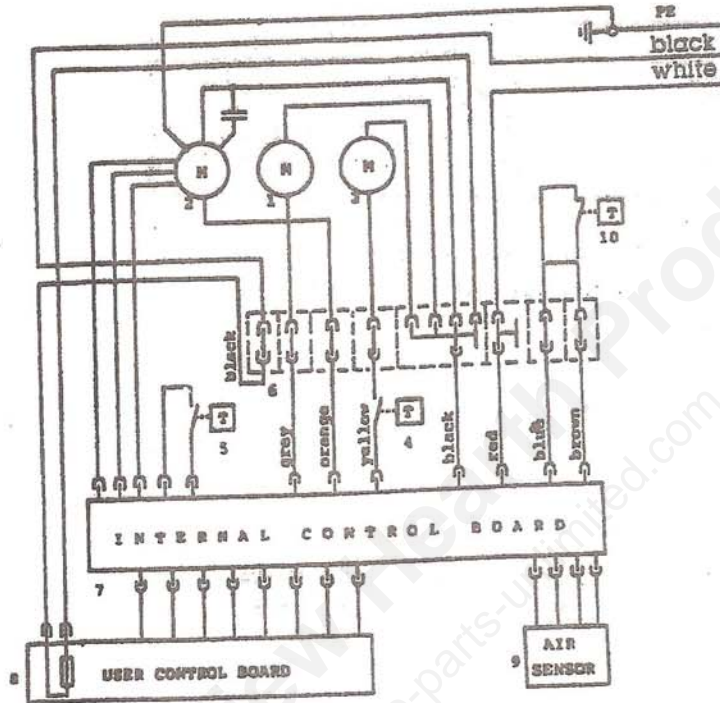

- 1 CONVECTION MOTOR
- 2 COMBUSTION MOTOR
- 3 AUGER MOTOR
- 4 HIGH TEMPERATURE SWITCH
- 5 LOW TEMPERATURE SWITCH
- 6 TERMINAL BLOCK
- 7 INTERNAL CIRCUIT BOARD
- 8 USER CONTROL BOARD
- 9 AIR SENSOR
- 10 JUMPER OR THERMOSTAT

10. DIFFERENCES BETWEEN THE INTEGRA INSERT AND FREESTANDING

The Integra series is available in either an Insert and a Freestanding configuration. The Insert and the F/S both boast the largest hopper capacities in the industry.

	Insert	F/S
Hopper capacity	99 lbs	112 lbs
Overall height	23 2/3"	32"
Gross weight	258 lbs	295 lbs
Hopper lid	5" x 24"	10" x 23"

The user control board on the Insert is mounted on the right hand side shroud panel, on the F/S the user control board is mounted on the right side panel on the stove.

CERTIFICATION

The Integra Insert and F/S are certified according to UL 1482. Testing on the Integra series was completed by Warnock Hersey to the USA and Canadian standards.

EFFICIENCY AND PELLET CONSUMPTION

A recent test in March, 1993, rated the Integra at 88.1% efficient, the cleanest operating stove tested. Heating capacity is 2000 - 2500 sqft. Heat output was measured at 7000 - 40000 BTU / hour. The auger adjustment regulates the pellet feed from 1.1lbs/hr on low to 5.6 lbs/hr on maximum. Maximum fuel consumption occurs when using smaller, softer pellets. For maximum efficiency select larger, harder pellets.

11. SCHEMATICS WITH SURGE PROTECTOR.

- > for interference with radio or TV.
- > supplied from Austroflamm

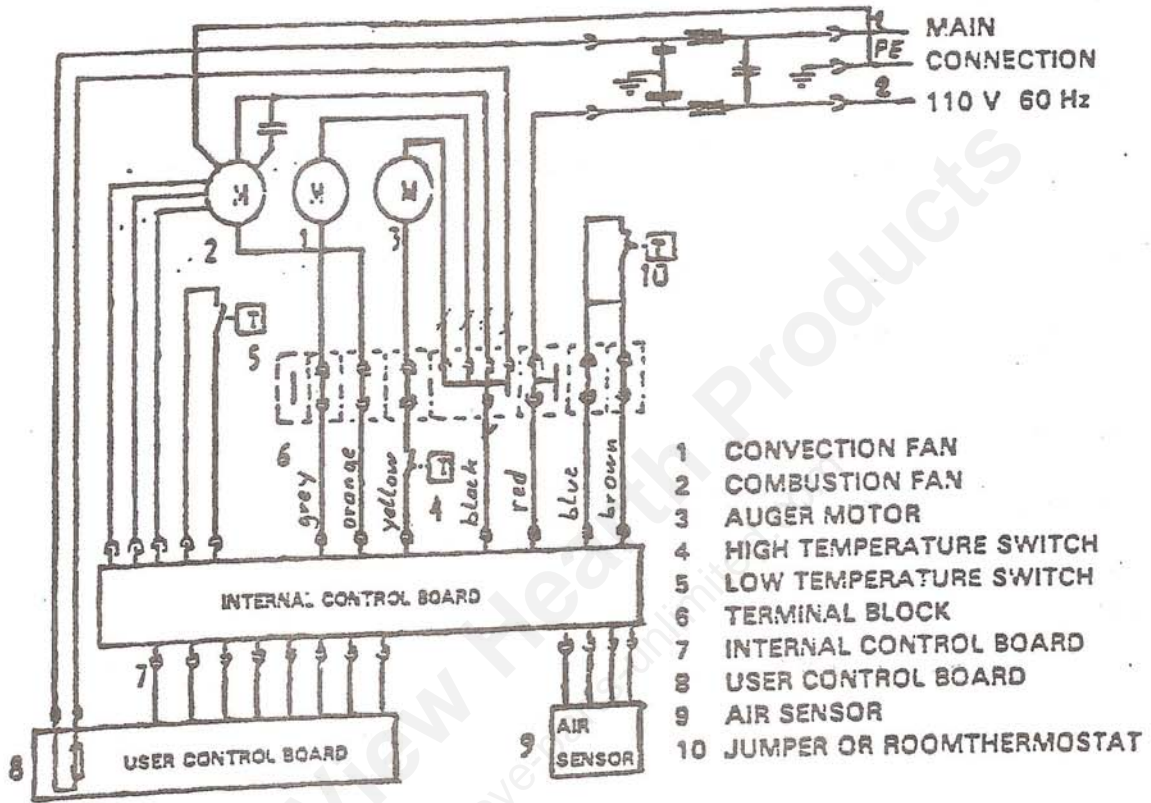

Austroflamm Problem Resolution Guide

Table of Contents

Combustion Motor	Lazy Flame / Window Sooting	2
	Motor running on "high" constantly	2
	Motor running on "low" constantly	2
	Motor on when stove is plugged in	2
	Motor remains off when switched ON	2
	Erratic high / low running motor	3
User Control Board	ON / OFF switch does not turn stove ON	3
	ON / OFF switch does not turn stove OFF	3
	No high / low control over stove	3
	Red light does not blink	3
Convection Fan	Motor on when stove is plugged in	4
	Motor not on after startup	4
	Motor running on "High" constantly	4
	Motor running on "Low" constantly	4
	Noisy / Grinding motor	4
Auger Motor	Motor on when stove is plugged in	5
	Motor remains off when switched ON	5
	Noisy / Grinding motor	5
	Motor running constantly	5
	Motor running erratically	5
	Fluid Leaking from Gear Box	5
	Red light blinking to slow / fast	5
Low Limit Switch	Stove shuts off after 15 min.	6
High Limit Switch	Auger will not operate	6
	Stove shuts off completely when hot	6
Self Ignitor	Pellets will not ignite	6
	Pellets start to smoke but	6
	no fire is in the burnpot	6

Austroflamm Problem Resolution Guide

Combustion Motor

<p>Lazy Flame / Window Sooting</p>	<p>Clean the stove thoroughly Check all gasketing around the stove Adjust the Door for a tight fit Check the Air and Auger Feed Potentiometers to insure they are working properly. Check the voltage to the combustion motor (positions #3 and #5 on terminal block) If the voltage is low, Adjust the Air Feed potentiometer on the User Control Board Check the Air Sensor for proper function</p>
<p>Motor running on "high" constantly</p>	<p>Is the Motor on when initially plugged in? If Yes, Refer to "Motor on when stove is plugged in" Check the Air and Auger Feed Potentiometers to insure they are working properly. Check the wiring at the terminal block if leads are on positions #3 & #5 Check the voltage at the terminal block (positions #3 & #5) If the voltage is 120V AC (line voltage) replace the Main Control Board If the voltage is staying on the maximum setting for the particular EPROM, Check the User Control Board's rheostat for proper operation (replace if necessary) Check the wiring to and from the User Control Board Check the wiring to and from the Main Control Board Replace the Eeprom on the Main Control Board Replace Main Control Board. Replace Combustion Motor</p>
<p>Motor running on "low" constantly</p>	<p>Does the unit have a thermostat? If Yes, remove the thermostat connection and put a jumper in its place. Retest the stove without the thermostat If Not, Check the jumper between positions #7 & #8 on the terminal block Is the Motor on when initially plugged in? If Yes, Refer to "Motor on when stove is plugged in" Check the Air and Auger Feed Potentiometers to insure they are working properly. Check the wiring at the terminal block (motor leads are on positions #3 & #5) Check the voltage at the terminal block (positions #3 & #5) If the voltage is staying on the minimum setting for the particular EPROM, Check the User Control Board's rheostat for proper operation (replace if necessary) Check the wiring to and from the User Control Board Check the wiring to and from the Main Control Board Replace the Eeprom on the Main Control Board Replace Main Control Board. Replace Combustion Motor</p>
<p>Motor on when stove is plugged in</p>	<p>Is there any other motors running? If Yes, Replace the Low Limit Switch If Not, Check the wiring on the terminal block (leads should be on position #3 & #5) Replace the Eeprom on the Main Control Board Replace the Main Control Board</p>
<p>Motor remains off when switched ON</p>	<p>Check power to the unit (Is the stove plugged in?) Check the fuse (replace if necessary) Inspect the wiring from the combustion motor to the terminal block. Check the voltage at the terminal block (positions #3 & #5) If there is voltage, Replace the Combustion Motor</p>

Austroflamm Problem Resolution Guide

Combustion Motor (continued)

Motor remains off when switched ON	Check the User Control Board's Rocker Switch
	Check the wiring to and from the User Control Board
	Check the wiring to and from the Main Control Board
	Replace the Main Control Board.
Erratic high / low running motor	Thoroughly clean the stove
	Does the unit have a thermostat?
	If Yes, remove the thermostat connection and put a jumper in its place.
	Retest the stove without the thermostat
	If Not, Check the jumper between positions #7 & #8 on the terminal block
	Inspect the wiring from the combustion motor to the terminal block.
	Check the voltage at the terminal block (positions #8 & #6)
	If the voltage fluctuates, Replace the Main Control Board
	Check the wiring to and from the User Control Board
	Check the wiring to and from the Main Control Board
Check the Air Sensor	
Replace the Combustion Motor	

User Control Board

ON / OFF switch does not turn stove ON	Check power to the unit (Is the stove plugged in?)
	Check the fuse (replace if necessary)
	Check the continuity to the rocker switch
	If the switch is not operating properly: Replace rocker switch
	Inspect the wiring from the User Control Board to the Main Control Board
Replace the Main Control Board	
ON / OFF switch does not turn stove OFF	Check the continuity to the rocker switch
	If the switch is not operating properly: Replace rocker switch
	Inspect the wiring from the User Control Board to the Main Control Board
	Unplug the stove and let cool down
Replace the Main Control Board	
No high / low control over stove	Does the unit have a thermostat?
	If Yes, remove the thermostat connection and put a jumper in its place.
	Retest the stove without the thermostat
	If Not, Check the jumper between positions #7 & #8 on the terminal block
	Check the User Control Board's thermostat for proper operation (replace if necessary)
	Inspect the wiring to and from the User Control Board
Inspect the wiring to and from Main Control Board	
Replace the Main Control Board	
Red light does not blink	Check if the auger motor is working properly (time the auger on / off time)
	If auger motor is operating properly: Replace User Control Board
	If auger motor is not operating properly: Refer to trouble shooting of auger motor

Austroflamm Problem Resolution Guide

Convection Fan

Motor on when stove is plugged in	Is there any other motors running?
	If Yes, Replace the Low Limit Switch
	If Not, Check the wiring on the terminal block (leads should be on position #2 & #6)
	Replace the Eprom on the Main Control Board Replace the Main Control Board
Motor not on after startup	Inspect the wiring from the convection motor to the terminal block.
	Check the wiring on the terminal block (leads should be on position #2 & #6)
	Check the voltage at the terminal block (positions #2 & #6)
	If there is voltage, Replace the Convection Fan
	If there is no voltage, inspect the wiring from the terminal to the Main Control Board
	Replace the Eprom on the Main Control Board Replace the Main Control Board
Motor running on "High" constantly	Is the Motor on when initially plugged in?
	If Yes, Refer to "Motor on when stove is plugged in"
	Check the wiring at the terminal block if leads are on positions #2 & #5
	Check the voltage at the terminal block (positions #2 & #5)
	If the voltage is 120V AC (line voltage) replace the Main Control Board
	If the voltage is staying on the maximum setting for the particular EPROM,
	Check the User Control Board's rheostat for proper operation (replace if necessary)
	Check the wiring to and from the User Control Board
	Check the wiring to and from the Main Control Board
	Replace the Eprom on the Main Control Board
	Replace Main Control Board. Replace Convection Fan
Motor running on "Low" constantly	Does the unit have a thermostat?
	If Yes, remove the thermostat connection and put a jumper in its place. Retest the stove without the thermostat
	If Not, Check the jumper between positions #7 & #8 on the terminal block
	Is the Motor on when initially plugged in?
	If Yes, Refer to "Motor on when stove is plugged in"
	Check the wiring at the terminal block (motor leads are on positions #2 & #5)
	Check the voltage at the terminal block (positions #2 & #5)
	If the voltage is staying on the minimum setting for the particular EPROM,
	Check the User Control Board's rheostat for proper operation (replace if necessary)
	Check the wiring to and from the User Control Board
	Check the wiring to and from the Main Control Board
Replace the Eprom on the Main Control Board	
Replace Main Control Board. Replace Convection Motor	
Noisy / Grinding motor	Carefully remove and clean the motor and fan assembly
	Replace the convection fan bushing
	If the noise still exists, Replace the convection fan

Austroflamm Problem Resolution Guide

Auger Motor

Motor on when stove is plugged in	<p>Check the wiring at the terminal block (motor leads should be positions #4 & #5)</p> <p>Replace the Main Control Board</p>
Motor remains off when switched ON	<p>Check for obstruction in auger shaft</p> <p>Check the auger shaft collar to see if it is secured properly</p> <p>Check power to the unit (Is the stove plugged in?)</p> <p>Check the fuse & replace if necessary</p> <p>Check the User Control Board's rocker switch for proper operation (replace if necessary)</p> <p>Inspect the wiring from the User Control Board to the Main Control Board.</p> <p>Inspect the wiring from the auger motor to the terminal block.</p> <p>Inspect the wiring from the terminal block to the Main Control Board.</p> <p>Is the red LED light on the User Control Board blinking?</p> <p>If the LED is blinking, check the auger motor to line voltage.</p> <p>If the motor operates on line voltage check the high limit switch.</p> <p>If the motor does not operate, Replace the Motor.</p> <p>If the LED is not blinking, Check the Air Sensor for proper operation. Replace if required.</p> <p>Is the Door Closed?</p> <p>Is the combustion fan turning fast enough to activate the auger?</p> <p>If Yes, Check the Air Sensor and the Hall IC Circuit</p> <p>If Not, Connect the combustion motor to line voltage</p> <p>If the motor operates on line voltage replace the Air Sensor.</p> <p>If the combustion motor does not run, replace the combustion motor</p>
Noisy / Grinding motor	<p>Check for obstruction in auger shaft</p> <p>Check the auger shaft collar to see if it is secured properly</p> <p>Replace Auger Motor</p>
Motor running constantly	<p>Is the red LED light on the User Control Board blinking?</p> <p>If the LED is blinking, replace the Main Control Board</p> <p>Check the wiring at the terminal block (motor leads should be positions #4 & #5)</p> <p>Replace the Main Control Board</p>
Motor running erratically	<p>Inspect the wiring from the auger motor to the terminal block.</p> <p>Inspect the wiring from the terminal block to the Main Control Board.</p> <p>Check the User Control Board's rheostat for proper operation (replace if necessary)</p> <p>Inspect the wiring to and from the User Control Board</p> <p>Inspect the wiring to and from Main Control Board</p> <p>Check the Air Sensor for proper operation</p> <p>Replace the Main Control Board</p> <p>Replace the Auger Motor</p>
Fluid Leaking from Gear Box	<p>Replace the Auger Motor</p>
Red light blinking to slow / fast	<p>Check / Adjust auger potentiometer on user control board</p>

Austroflamm Problem Resolution Guide

Low Limit Switch

Stove Shuts off after 15 min.	Check power to and through switch (8V DC)
	If there is power to the switch, replace the Low Limit Switch
	Inspect the wiring from the Main Control Board to the Low Limit Switch.

High Limit Switch

Auger will not operate	Check power to and through switch (110 V AC)
	Refer to "Motor remains off when turned ON" in the Auger Motor section.
Stove shuts off <u>completely</u> when hot	Replace the High Limit Switch

Self Ignitor

Pellets will not ignite Note: To check the voltages the stove must be in start-up.	Check to see if the burnpot has an ignition hole on the left side.
	Check the position of the burnpot ignition hole and the ignitor are aligned properly.
	Check to see if there is an EPROM 3.1 and higher installed on the main circuit board.
	Inspect the wiring / connections from the heating element to the ignitor board.
	Inspect the wiring / connections from the ignitor board to the terminal block.
	Verify that voltage (110 VAC) is at the terminal block pos. # 5 & pos. #6.
	If there is no voltage, refer to "No power to stove".
	If there is voltage, verify that voltage is to the ignitor board (110 VAC).
	Verify that voltage (110 VAC) is at the leads to the heating element
	If there is voltage, test the heating element (should be 65 ohms +/- 10%)
If there is no voltage, replace the ignitor board.	
Pellets start to smoke but no fire is in the burnpot	Check to see if the burnpot has an ignition hole on the left side.
	Check the position of the burnpot ignition hole and the ignitor are aligned properly.
	Verify that voltage (110 VAC) is at the leads to the heating element
	If there is voltage, test the heating element (should be 65 ohms +/- 10%)
	If there is no voltage, replace the ignitor board.
	Verify that the heating element has 110 VAC for 10 min. during start-up. If the time is shorter than 10 min., Replace the EPROM.

Integra Pellet Component Symptom / Problem Guide

Air Sensor	<p>Lazy Flame</p> <p>No Red Light and / or the Combustion Motor is at 120V</p> <p>Intermittent Auger Feed</p> <p>No Power to the stove</p> <p>Erratic Operation</p> <p>One or All motors at 120V</p> <p>No Red Light</p> <p>Red light blinking fast (flashing)</p> <p>Improper Voltages to Motors</p> <p>Stove blows fuses</p> <p>Stove stops after startup</p> <p>Convection and Combustion motors are running when stove is plugged in</p> <p>New Switch won't work</p> <p>No auger feed yet Red Light blinks</p> <p>Intermittent Auger Feed</p> <p>New Switch won't work</p> <p>No Control over the stove</p> <p>Motors do not adjust when knob turned</p> <p>Stove won't turn On</p> <p>Noisy Motor / Squealing / Ticking</p> <p>Motor will not run on minimum setting</p> <p>Fan goes High / Low</p> <p>Motor will not run at all</p> <p>Noisy Motor / Squealing / Ticking</p> <p>Motor will not run on minimum setting</p> <p>Erratic Motor Operation</p> <p>Motor at 120V</p> <p>Noisy Motor / Squealing / Grinding</p> <p>Motor will not work at all</p> <p>Intermittent Auger Feed</p> <p>Intermittent Motor Operation</p> <p>Stove blows fuses</p> <p>No User Board function</p> <p>No Air Sensor function</p> <p>Erratic Operation</p>	<p>Dirty Stove, Dirty or Burned Air Sensor, Obstructed Air Intake</p> <p>Air Sensor is not producing signal or Circuit Board is not understanding it</p> <p>Dirty Stove, Dirty or Burned Air Sensor, Obstructed Air Intake</p> <p>Dirty Stove, Dirty or Burned Air Sensor, Obstructed Air Intake</p> <p>Defective Transformer or Voltage Regulator, Check fuse and fuse holder</p> <p>Defective Board Outputs, Defective EPROM, Defective Board Inputs, Check Air Sensor & Hall IC</p> <p>Defective Triac, Defective Board Outputs, Defective EPROM, Check Air Sensor</p> <p>Defective Auger Output, Check Air Sensor</p> <p>Defective EPROM, Defective Board Output</p> <p>Defective EPROM, Defective Board Outputs, Dirty Stove, Check Air Sensor & Hall IC</p> <p>Defective Board, Check Amperages on all motors</p> <p>Defective Switch or Wiring to the switch</p> <p>Defective Switch or Wiring to the switch.</p> <p>Check for melted wiring on Combustion Motor housing</p> <p>Switch is tightened to tight</p> <p>Defective Switch or Wiring to the switch</p> <p>Defective Switch or Wiring to the switch.</p> <p>Switch is tightened to tight</p> <p>Defective Rheostat, Check if the thermostat jumper is intact</p> <p>Defective Rheostat, Check if the thermostat jumper is intact</p> <p>Defective Rocker Switch</p> <p>Dirty Fan, Defective or bent squirrel cage, defective outer housing</p> <p>Dirty Fan, Defective fan motor (Drawing to much amperage)</p> <p>Defective Fan Motor (Drawing to much amperage), Check voltages to fan for proper board function</p> <p>Dirty Fan, Defective fan motor (Drawing to much amperage) Usually blows a fuse</p> <p>Dirty Fan, Defective or bent impeller blade, defective bearings</p> <p>Dirty Fan, Defective fan motor (Drawing to much amperage)</p> <p>Defective Fan Motor (Drawing to much amperage), Check voltages to fan for proper board function</p> <p>Defective Fan Motor, Check voltages to fan for proper board function, Check Air Sensor & Hall IC</p> <p>Check Air Sensor & Hall IC, Check Board Triac.</p> <p>Grease in gear box is away from the gears, Loose outer screw Defective gear box</p> <p>Defective motor or gear box, Spindle in the armature assembly is dropping out of the gear box</p> <p>Spindle in the armature assembly has dropped out of the gear box, Check Circuit Bd & High Limit</p> <p>Check Wiring for Crimps, Cuts or bad connections, Check for continuity through wires</p> <p>Check wiring for grounding out to stove body</p> <p>Check Wiring for Crimps, Cuts or bad connections, Check for continuity through wires</p> <p>Check Wiring for Crimps, Cuts or bad connections, Check for continuity through wires</p> <p>Check Wiring for Crimps, Cuts or bad connections, Check for continuity through wires</p>
Circuit Board		
Low Limit Switch		
High Limit Switch		
User Control Board		
Convection Motor		
Combustion Motor		
Auger Motor		
Wiring Harness		