

REVO

Operating Manual



1. PREFACE	3
Explanations to symbols	3
Spare part overview exploded diagram	4
Spare part overview article numbers	6
Dimensions	7
Technical data.....	7
Amount of fuel	7
Packaging	7
Electrical connection	7
2. IMPORTANT INFORMATION	8
General warning and safety information	8
First heating.....	8
Safety distances	8
Prior to set up.....	9
The correct chimney connection	9
3. BRIEF INFORMATION ON FUEL - PELLETS	10
What are pellets?	10
Wood pellet specification according to ENplus – A1	10
Pellet container refilling during operation	10
Pellet storage	10
4. TECHNOLOGY AND SAFETY FUNCTIONS	11
Operating comfort.....	11
Top efficiency - lowest emissions.....	11
Overheating.....	11
Low-temperature shutdown	11
Electrical excess current protection.....	11
Automatic cleaning cycle.....	11
Component monitoring	11
Auger motor monitoring	11
Power failure (during heating)	11
Power failure (during the initial stage).....	11
5. INSTALLING THE STOVE	12
General information	12
Connection to the chimney	12
Connecting to a steel chimney	12
Combustion air.....	12
Feeding in external combustion air.....	12
6. ASSEMBLY/DISMANTLING STOVE AND OPTIONS	13
Disassembly of the front side casing.....	13
Disassembly of the rear side panel.....	13
7. INTERNAL CONTROLS	14
Basics	14
Operation	14
EASY MODE - simple heating operation	14
EASY OFF - inactive state	14
Start - scavenge - tip - ignition	14
Stopping during ignit or startphase.....	15
EASY 40 – operation	15
Cleaning and tipping during operation	15
EASY 40 – switch off.....	15
Extended heating operation - HEAT MODE - comfort funktions	16
Menu structure and main menu level	17
Main menu time - time adjustment	18
Main menu setup - additional functions	20
Main menu info - additional information	22

8. COMFORT OPTIONS	24
RIKA room sensor/RIKA radio room sensor.....	24
RIKA phone option – GSM	24
RIKA interface for various options.....	24
External room thermostat	24
External connection cable bridge	24
9. MODES	25
Pellet operation Heat/Easy/Automatic/Room	25
Pellet container refilling during operation	25
Emergency operation - heating up without electrical Ignition.....	25
10. MENU OVERVIEW V1.40	26
11. WARNINGS AND ERROR MESSAGES	28
12. CLEANING AND MAINTENANCE	29
Basic information	29
Open the combustion chamber door	29
Cleaning of the burn pot - daily	29
Empty the ash drawer.....	29
Cleaning flue pipes	30
Clean flue gas collecting channel.....	30
Clean flue gas fan housing.....	31
Cleaning the flame temperature sensor	31
Cleaning the pellet container.....	31
Cleaning the door glass	31
Bearings.....	31
Checking door seal	31
Cleaning of painted surfaces.....	31
Cleaning the flue gas channels.....	31
13. PROBLEMS - POSSIBLE SOLUTIONS	32
Problem 1	32
Problem 2	32
Problem 3	32
14. INSTRUCTIONS FOR COMMISSIONING PROTOCOL	33
15. GUARANTEE	35

1. PREFACE

Explanations to symbols



...Important Note



...Hex #8



... Hex #10



...Useful Tip



...open end wrench



...manually

Spare part overview exploded diagram

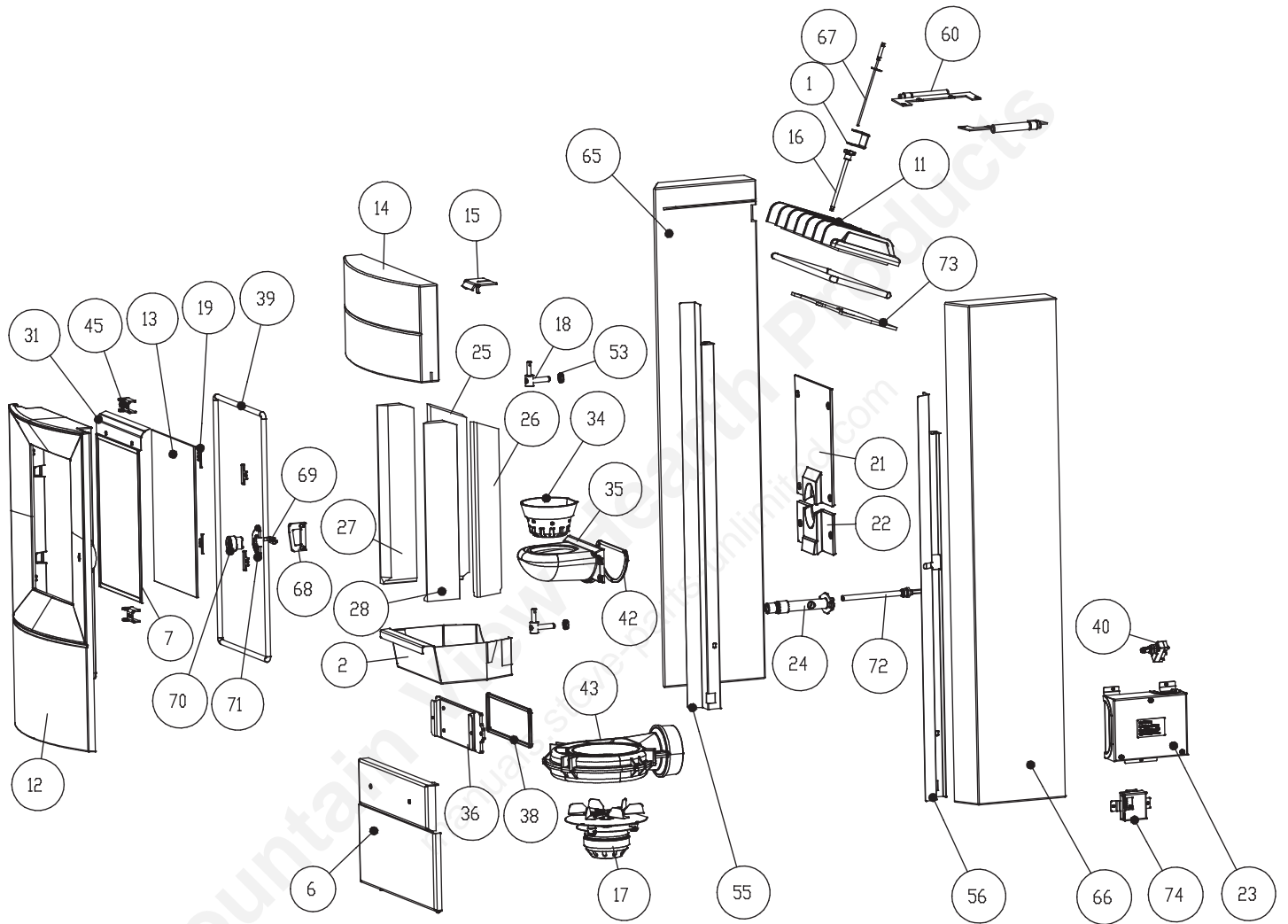

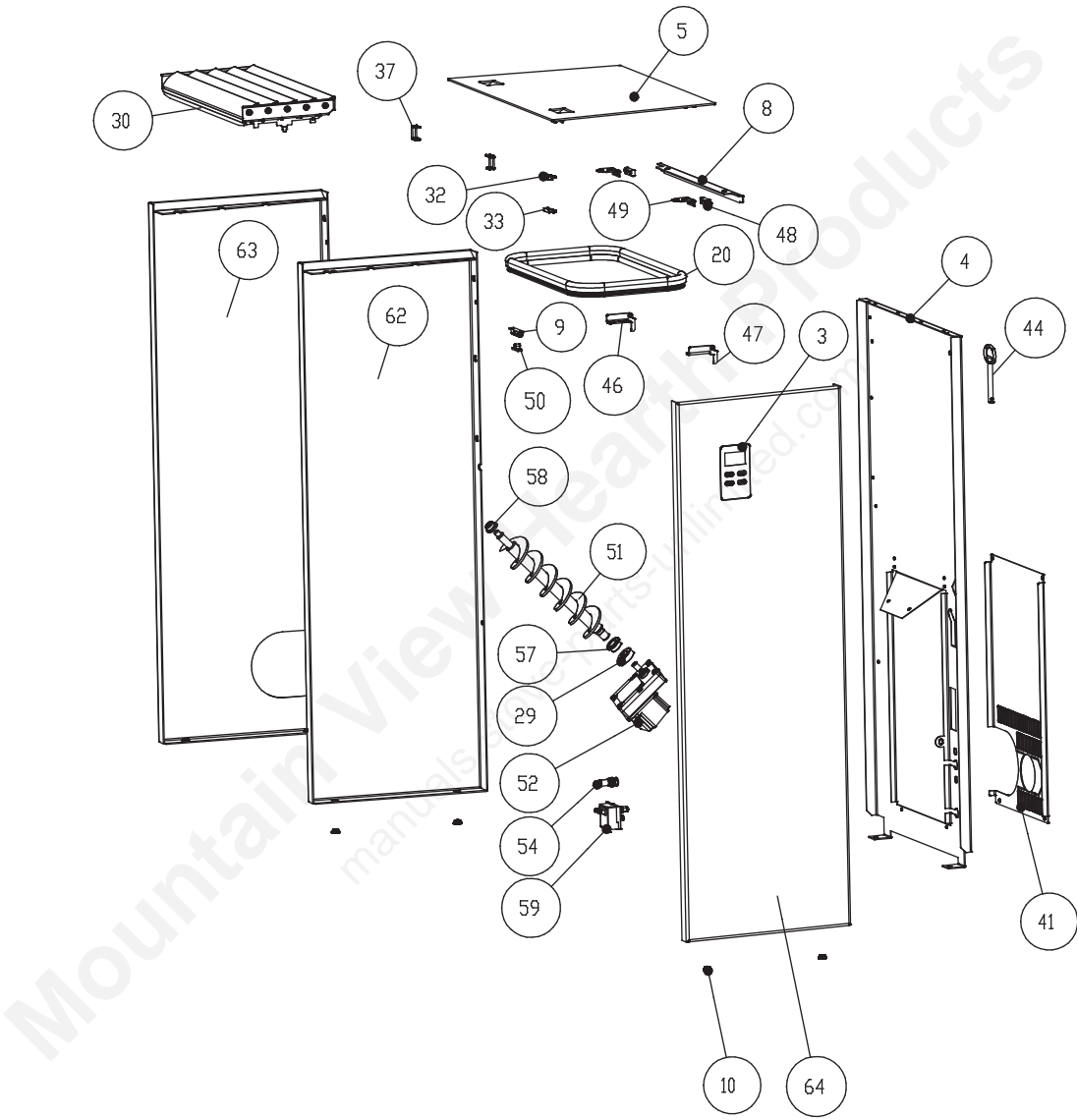

Spare part overview article numbers

Nr.	Art.Nr.	Description	Nr.	Art.Nr.	Description	Nr.	Art.Nr.	Description
1	L01441	Pressure bracket	28	Z33790	Firebrick lining front right		Z34201	Side casing sandstone left
2	L01447	Ash drawer	29	Z11915	Lock ring conveyer screw		Z36818	Side casing stone white left
3 *1	B15621	Key display	30	B15506	Convection fins metallic grey	66	Z32869	Side casing soapstone right
3 *2	B16574	Touch-Display plug-in		B15646	Convection fins black		Z34202	Side casing sandstone right
4	Z34176	Reservoir rear gray	31	Z34137	Air blade		Z36817	Side casing stone white right
	Z34193	Reservoir rear black	32	N111732	Magnetic switch top part	67	B16114	Temperature sensor
5	Z34194	Container lid grey (till nr.: 1305473)	33	N111733	Solenoid switch bottom part	68	L01998	Closure flap
	Z34195	Container lid black (till nr.: 1305473)	34	Z32345	Fire trough		L00427	Closure flap black
	Z35609	Container lid grey (from nr.: 1305474)	35	Z33692	Fire trough holder	69	L01449	Lock tongue
	Z35608	Container lid black (from nr.: 1305474)	36	B16320	Cleaning opening metallic	70	Z33794	Locking bolt
6	Z34141	Cover panel, bottom grey		B16352	Cleaning opening black	71	L01450	Closure plate
	Z34196	Cover panel, bottom black	37	Z26051	Rest spring	73	Z34438	Baffle plate cast iron
7	N103693	Flat seal black 8x2	38	N111280	Sealing cord Ø8mm	74	B16030	Add. board motor
8	Z34197	Cover panel grey (till nr.: 1305473)	39	N100476	Sealing cord black Ø10mm	*1	B16058	Wiring harness (for Key display)
	Z34198	Cover panel black (till nr.: 1305473)	40	N111825	Door contact switch			
	Z35611	Cover panel grey (from nr.: 1305474)	41	L01777	Rear wall grey	*2	B17364	Wiring harness (for touch-display)
	Z35610	Cover panel black (from nr.: 1305474)		L01812	Rear wall black	*1	Z33136	Cable for Key display
9	N110461	Double ball catch	42	N103066	Round sealing strip black D06	*2	Z35018	Cable 1,25m for touch-screen
10	N111730	Grommet	43	B16155	Induced draft fan housing		L00797	Motor plate
11	Z34135	Comb. Chamber cover grey		B15913	Induced draft fan assy		N111604	Fuse 2,5A
	Z33788	Comb. chamber cover black	44	N112017	Key		E15471	Sealing kit
12	Z34084	Combustion chamber door	45	L01448	Hinge		*1	till serial number 1346067
	B16324	Combustion chamber door assy	46	L01772	Hinge left		*2	from serial number 1346068
	Z34235	Combustion chamber door metallic		L02542	Hinge left (from nr.: 1305474)		*3	till serial number 276572
	B16380	Combustion chamber door metallic assy	47	L01773	Hinge right		*4	requires 2,5A fuse (N111604) till serial number 1346068
13	Z32866	Combustion chamber door glass		L02543	Hinge right (from nr.: 1305474)		*5	up to serial number 1331613 the motor plate (L00797) must be supplied as a spare part when replacing the plastic bearing Di16 (Z35182).
14	Z32867	Front stone soapstone	48	Z30494	Hinge shaft			
	Z33187	Sandstone front		Z34854	Hinge shaft			
	Z36819	Front stone white	49	L01813	Hinge holder (till nr.: 1305473)			
15 *3	L00838	Front holder		L02498	Hinge holder (from nr.: 1305474)			
	L01921	Front holder	50	N110461	Double ball catch			
16	B16053	Sensor tube	51	B12301	Auger			
17	N111581	Induced draft fan motor	52	N112030	Screw motor, stepless			
18	B15807	Hinge BA1	53	N100483	Hexagonal nut M10			
19	L00475	Glass holder	54	N107887	Fuse holder			
20	N111731	Container seal	55	Z34138	Cover panel left metallic grey			
21	Z34132	Cast rear panel, top, metallic grey		Z34200	Cover panel left black			
	Z33786	Cast rear panel, top black	56	Z34139	Cover panel right metallic grey			
22	Z34131	Cast rear panel bottom metallic grey		Z34199	Cover panel right black			
	Z33785	Cast rear panel bottom black	57 *5	Z35182	Friction bearing Di16			
23 *1	B15856	Motherboard C2 (for Key display)	58	Z35183	Friction bearing Di10			
23 *2	B16561	Mainboard USB11	59	N111586	Safety temperature limiter			
24 *4	B17166	Ceramic ignition	60	B16328	Stone holder left/right			
25	Z33791	Firebrick lining rear left	62	L01781	Side casing panel back left grey			
26	Z33792	Firebrick lining rear right		L01814	Side casing panel back left black			
27	Z33789	Firebrick lining front left	63	L01816	Side casing connection left grey			
				L01815	Side casing connection left black			
			64 *1	L01780	Side casing back right grey			
			64 *2	B17472	Side casing back right grey (for touch-display)			
			64 *1	L01817	Side casing back right black			
			64 *2	B17471	Side casing back right black (for touch-display)			
			65	Z32870	Side casing soapstone left			

Note: Please consider the powdercoated parts can differ slightly in colour and colour effects though they are elaborated in high quality.

Dimensions

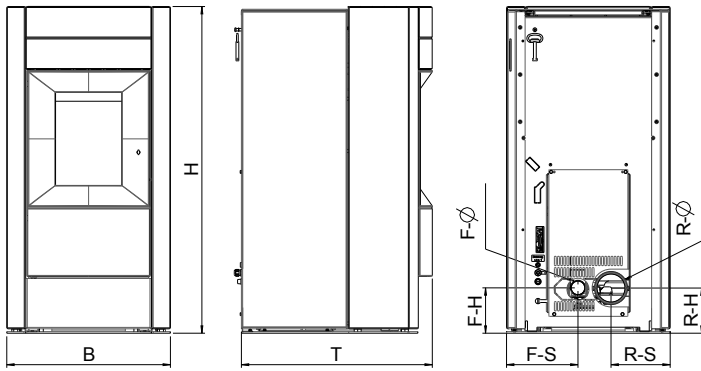

Technical data

Dimensions

Height	[mm]	1038
Width	[mm]	520
Corpus depth	[mm]	606

Weight

Weight without shell	[kg]	150
Weight with shell	[kg]	240
Storage mass	[kg]	90

Flue pipe connection

R - Ø flue pipe outlet	[mm]	100
RO - H original angle pipe connection height	[cm]	-
RO - T1 original angle pipe total depth	[cm]	-
RO - T2 original angle pipe distance to rear wall	[cm]	-
RO - T3 depth from rear wall to middle of flue pipe	[cm]	-
RO - S original angle pipe side distance	[cm]	-
R - H rear connection height	[cm]	14
R - S rear connection side distance	[cm]	19

Fresh air connection

F - Ø diameter	[mm]	50
F - H connection height	[cm]	15
F - S side distance	[cm]	23

Convection air connection

K - Ø diameter	[mm]	-
K - H connection height	[cm]	-
K - S side distance	[cm]	-

Amount of fuel

	Nominal load	Part load
Amount of fuel	~2,1kg*	~0,6kg*
Burn time at full pellet hopper	ca. 22h	ca. 53h

*Practical values may vary depending on pellet quality.

Note

Pellet consumption depends on the size of the pellets. The larger the pellet, the slower the feed and vice versa.

Technical data

Heating power range	[kW]	2,5 - 9
Room heating capacity (depending on house insulation)	[m ³]	50 - 240
Fuel consumption	[kg/h]	bis 2,1
Pellet container capacity	[l]/[~kg]	59/~38
Electric supply	[V]/[Hz]	230/50
Average electrical input	[W]	~ 20
Fuse	[A]	2,5 AT
Efficiency	[%]	91,1
CO ₂	[%]	14,3
CO-emission on 13% O ₂	[mg/m _N ³]	163
Dust emission	[mg/m _N ³]	9
Exhaust	[g/s]	4,9
Exhaust temperature	[°C]	175,3
Chimney draft requirement	[Pa]	3

The owner of small firing systems or the person authorised for the small firing system is to keep the technical documentation and is to submit it to the authorities or the chimney sweep on request.

Note

Please observe the national and European standards as well as local regulations concerning the installation and operation of firing installations!

Packaging

Your first impression is important to us!

The packaging of your new stove provides excellent protection against damage. However damage to the stove and accessories may still occur during transport.

Note

Therefore please check your stove on receipt for damage and completeness! Report any deficiencies to your dealer immediately! Pay particular attention during unpacking that the stone panels remain intact. Scratches to the material can easily occur. Stone panels are excluded from the warranty.

The packaging of your new stove is environmentally neutral to a great extent.

Tip

The wood used in the packaging has not been surface treated and may therefore be burnt in your stove. The cardboard and film (PE) can be disposed of via the municipal waste collection for recycling.

Electrical connection

The stove is supplied with an approx. 2m long connecting cable with a Euro-plug. This cable is to be connected to a 230Volt/50Hz socket. The average electrical power consumption is about 20 Watt in heating operation and approx. 150 Watt during automatic ignition. The connection cable must be laid in a way that there is no contact to any sharp edges or hot surfaces of the stove.

2. IMPORTANT INFORMATION

General warning and safety information

Observance of the introductory general warning information is imperative.

- Read the entire manual thoroughly before installing and putting the stove into service. Observe the national provisions and laws as well as the regulations and rules applicable locally.
- RIKA stoves should only be installed in rooms with normal humidity (dry areas according to VDE 0100 Part 200). The furnaces are not splash water protected and may not be installed in wet areas.
- Only approved transport equipment with sufficient load carrying capacity may be used with your heating appliance.
- Your heating appliance is not suitable for use as a ladder or stationary scaffolding.
- The burning of fuel releases heat energy that lead to extensive heating of the stove surfaces, doors, door and operating handles, glass, flue pipes and possibly the front wall. Refrain from touching these parts without appropriate protective clothing or equipment e.g. heat-resistant gloves or means of operation (operating handle).
- Make your children aware of this particular danger and keep them away from the stove during heating.
- Only burn approved heating materials.
- The combustion or introduction of highly flammable or explosive materials such as empty spray cans etc. in the combustion chamber and storing them near the stove is strictly prohibited due to the danger of explosion.
- No light or flammable clothing is to be worn when post-heating.
- Use the heat-resistant gloves supplied to open the doors of your stove.
- Make sure that no embers fall out of the combustion chamber onto inflammable material.
- Placing non-heat resistant objects on the stove or near it is prohibited.
- Do not place clothing on the stove to dry.
- Laundry racks etc. must be placed at a sufficient distance to the stove – ACUTE DANGER OF FIRE!
- When your stove is burning, the use of highly inflammable and explosive materials in the same or adjacent rooms is prohibited.
- If the stove is heated in continuous operation, the cleaning intervals are shorter. Increased wear, especially of the thermally stressed parts, is the result. Please therefore strictly follow the requirements for cleaning and maintenance!

Note
Waste and liquids may not be burnt in the stove!

Note
To prevent your stove from overheating of the internal components, do never cover the convection fins!

Note
CAUTION when filling the pellet container. The opening of the pellet container is sufficiently dimensioned to ensure easy filling. Take great care that no pellets drop to the convection fins and the hot stove body. This can cause a lot of smoke.

Tip
Therefore we recommend refilling the pellet container at a cold stove.

Note

Your stove will expand and contract during the heating and cooling phase. This can sometimes lead to slight bending or cracking noises. This is normal and is no reason for a complaint.

First heating

The stove body, just as various steel parts, cast iron parts and the flue pipes are painted with a heat resistant paint. During the first heating the paint dries out completely. This may cause a slight smell. Touching or cleaning the painted surfaces during the curing should be avoided. The hardening of the paint is finished after the first heating with high power.

Safety distances

Note

1. To non-combustible objects
a > 40 cm b > 10 cm
2. To combustible objects and reinforced concrete load-bearing walls
a > 80 cm b > 20 cm

Tip

please observe a minimum distance of 20 cm behind and sideways the stove for maintenance.

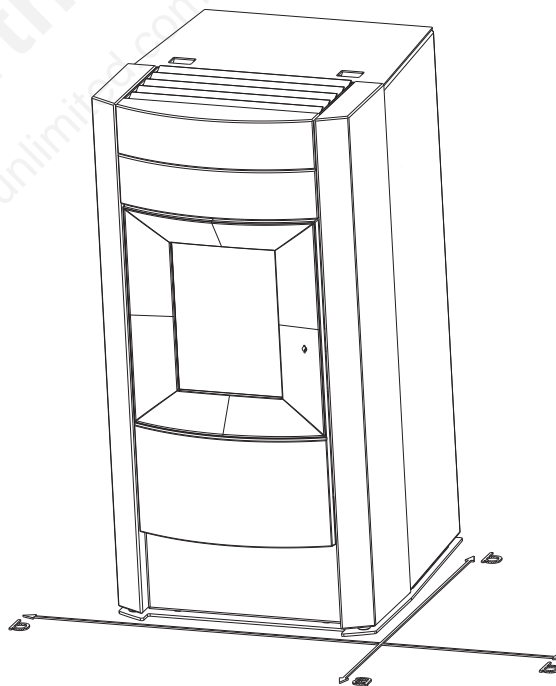

Prior to set up

Floor bearing capacity

Ensure that the substructure is capable of bearing the weight of the stove prior to set-up.

Note

No modifications may be made to the firing installation. This also leads to loss of warranty and guarantee.

Floor protection

A base is recommended (glass, sheet steel or ceramic) if the floor is combustible (wood, carpet, etc.). Please observe the respective local regulations and rules.

Flue pipe connection

- Flue pipes pose a particular source of hazard regarding gas leaks and fire. Get the advice of an authorised specialist company for the layout and assembly.
- Please observe the corresponding installation guidelines for walls panelled with wood when connecting your flue pipes to the stove.
- Observe the formation of flue gas (atmospheric inversion) and draughts when the weather is unfavourable.
- Infeed of too little combustion air can lead to smoke in the rooms or to flue gas leaks. Hazardous deposits in the stove and chimney may also occur.
- If flue gas escapes, let the fire burn out and check whether all the air inlet openings are free and the flue gas pipes and the stove pipe are clean. If in doubt notify the master chimney sweep since draught malfunctions may be connected to your chimney.

The correct chimney connection

There are several ways to connect your stove to the chimney, eg:

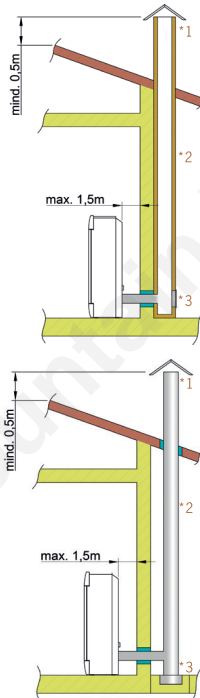

1) wind break, 2) chimney, 3) inspection opening

For the selection of the connection and to ensure a proper connection between the stove and chimney, please read the guide „INSTALLING THE STOVE“ or ask your local chimney sweep.

Stoves type 1 (BA 1):

- Suitable for multiple occupancy. (Note the different country regulations.)
- These may only be operated with the combustion chamber door closed.
- The combustion chamber door is to be kept closed when the stove is not in operation.
- Fouling of the chimney i.e. deposits of highly inflammable materials such as soot and tar and subsequently fire in the chimney may occur if the chimney is miscalculated and dimensioned wrong.
- If this occurs, disconnect the mains plug. Phone the fire brigade and get yourself and other residents out of harm's way.

Note

Your pellet stove has been tested as a room-air independent stove according to EN14785. It can be operated room air dependent or room air independent.

ROOM-AIR INDEPENDENT OPERATION:

The stove is certificated for type FC52x / FC62x of the approval principles for the inspection and evaluation of ambient air independent fireplaces specified by the Deutsches Institut für Bautechnik (DIBT) (German Institute for Building Technology). Thanks to an air-tight configuration of the air supply line and flue pipes the stove may be operated in air-tight rooms and in rooms with room-air installations (e.g. controlled ventilation and venting systems, extractors etc.).

ROOM-AIR DEPENDENT OPERATION:

In combination with room-air installations (e.g. controlled ventilation and venting systems (extractors etc.) it must be ensured that the stove and the room air system are monitored and safeguarded mutually (e.g. via a differential pressure controller). The combustion air infeed of approx. 20 m³/h must be ensured.

Please observe the respective local regulations and rules in consultation with your master chimney sweep. For changes after the printing of this manual, we can not assume any liability. We reserve the right to change without notice.

3. BRIEF INFORMATION ON FUEL - PELLETS

What are pellets?

Wood pellets are a standardised fuel. Every manufacturer must adhere to certain conditions in order to enable flawless, energy-efficient heating. Pellets are made from wooden waste, from sawmills and planing workshops, as well as from residue from forestry operations. These “starting products” are crushed, dried, and pressed into Pellet “Fuel” without any bonding agent.

ENplus – Pellets

This ENplus standard sets benchmarks in the European pellet market. The traceability of pellets is ensured thanks to the use of identification numbers. The pellet manufacturers’ production facilities and manufacturing processes are reviewed every year. A quality assurance system ensures the pellets comply with the requirements of the new standard and that the conditions for trouble-free heating are guaranteed



Wood pellet specification according to ENplus – A1

Parameter	Measure	ENplus-A1
diameter	mm	6 (±1) ²⁾
length	mm	3,15 bis 40 ³⁾
buld density	kg/m ³	≥600
calorific value	MJ/kg	≥16,5
water content	Ma.-%	≤10
fine fraction (<3,15mm)	Ma.-%	≤ 1
mechanical rigidity	Ma.-%	≥97,5 ⁴⁾
ash content	Ma.-% ¹⁾	≤0,7
ash softening temperature	(DT) °C	≥1200
chlorine content	Ma.-% ¹⁾	≤0,02
sulphur content	Ma.-% ¹⁾	≤0,03
nitrogen content	Ma.-% ¹⁾	≤0,3
copper content	mg/kg ¹⁾	≤10
chrome content	mg/kg ¹⁾	≤10
arsenic content	mg/kg ¹⁾	≤1
cadmium content	mg/kg ¹⁾	≤0,5
mercury content	mg/kg ¹⁾	≤0,1
lead content	mg/kg ¹⁾	≤10
nickel content	mg/kg ¹⁾	≤10
zinc content	mg/kg ¹⁾	≤100

1) in an anhydrous state

2) diameter must be specified

3) a maximum of 1% of the pellets may be longer than 40 mm,

max. length is 45 mm

4) the limit value of ≥97,7 Ma.-% applies when conducting measurements with a lignotester (internal control)

Your pellet stove is only approved for the burning of pellets of tested quality. Please ask your pellet stove dealer for tested fuel and a list of monitored fuel manufacturers.

Note

Only burn pellets that have been inspected according to ENplus-A1. Using poor quality or prohibited pellet fuel will have a negative effect on the function of your pellet stove and can also lead to the warranty becoming null and void, as well as the product liability connected with this.

Note

Burning straw, maize, woodchips etc. is not permitted! Observe waste incineration legislation! Non-observance of these regulations makes void all warranty and guarantee claims and may impair the safety of the unit!

Pellet container refilling during operation

Note

CAUTION when filling! Avoid direct contact between the plastic bag and the hot stove. Immediately remove all pellets that have fallen on the hot stove or next to the container!

We recommend always having a suitable amount of pellets in the container to prevent the fire from extinguishing due to a lack of fuel. Check the level frequently. However the container lid should be kept closed, except during filling.

If you refill the container during operation (open the container lid), the fan will speed up and the pellet auger will stop; operation will only be continued once the container lid is closed again (see WARNING AND ERROR MESSAGES)

Pellet container capacity (see Technical Data).

Pellet storage

In order to guarantee problem free burning of the wooden pellets, it is imperative necessary to store the fuel as dry as possible and free from impurities.

Pellets should not be kept in sacks outdoors or stored in a manner where they are exposed to the environment. This can lead to blockages in the screw conveyor.

Note

“Screw stoppers” are excluded from the warranty.

4. TECHNOLOGY AND SAFETY FUNCTIONS

The technological advances in your new combi stove are the result of years of testing and practical experience. The practical advantages of your pellet stove are convincing:

Operating comfort

The microprocessor-controlled combustion regulation optimises the interaction of flue gas blower and screw using the current combustion chamber temperature. This guarantees optimum combustion and operating status.

All function can be regulated centrally using the integrated operating unit. The intuitive graphic interface permits easy operation; all the settings can be made quickly and simply.

Top efficiency – lowest emissions

A very great heat exchange surface together with optimum combustion air control leads to excellent fuel utilisation.

Fine continuous pellet dosing in an optimised burner pot made of high-quality grey cast iron leads to virtually complete combustion with very good exhaust gas values - and this is guaranteed in every operating phase.

Note

During operation, the flame noise, pellets dropping and actuation of the electronic components are audible due to the automatic control.

Overheating

A safety temperature limiter (STL) switches the stove off automatically on overheating. Once the stove has cooled, the STB at the stove rear must be unlocked manually (pressed). The stove is ready for operation again after acknowledging the error message at the internal unit.

Note

Maintenance and cleaning work must be performed if overheating occurs! If this error recurs, operation without danger is no longer guaranteed; notify customer service immediately.

Low-temperature shutdown

The unit switches off if the stove cools below a minimum temperature. This switch-off may occur if pellet ignition is delayed.

Electrical excess current protection

The stove has a main fuse (at the rear) to protect against excess current.

Automatic cleaning cycle

The speed of the flue gas fan is increased every hour for a short period to blow ash from the burn pot, increasing the operational safety. The status indicator CLEANING appears on the display.

Only for stoves with turning grids:

Every 6 hours (interval adjustable) an additionally automatic cleaning cycle is performed. The stove stops, the automatic cleaning tilts the grid and then re-ignites the stove. The status indicator CLEANING appears on the display continuously. The cleaning procedure with tilting the grid is to convey ash and clinker from the burn pot into the ash drawer.

Note

This additional function does not replace a manual cleaning as described in CLEANING and MAINTENANCE, as this is absolutely necessary to do regularly.

Note

Due to the turning grid there is a certain generation of noise during the automatic cleaning cycle.

Component monitoring

All the electrical components used are continuously monitored during operation. If a component is defective or can no longer be actuated correctly, then operation is stopped and a warning or error message is issued.

Auger motor monitoring

Too long or wet pellets as well as pellets with too high dust content (see BRIEF INFORMATION ON FUEL PELLETS) can cause so-called “auger jammers” in the auger channel. This may also happen if the pellets accumulate in the burn pot and the backlog reaches into the chute. The auger motor reacts in both cases with an increased current consumption, which causes the error message: DISCHARGE MOTOR BLOCKED. The stove will be stopped. Please call the customer service immediately.

Power failure (during heating)

After a brief power failure, the operating functions that were set before the power failure, continues. If the power failure lasts longer, the stove goes to start phase if sufficient temperature or embers are present. If the power failure lasts too long, the stove goes into the stop phase. The flue gas fan continues to burn any pellet residues (approximately 10 minutes). Then it will restart automatically.

Power failure (during the initial stage)

After a brief power failure the boot process continues. If the power failure lasts longer, the stove is in the stop phase. The flue gas fan continues to burn any pellet residues (approximately 10 minutes). Then it will restart automatically.

5. INSTALLING THE STOVE

General information

Note
Assembly may only be performed by authorised specialist companies.

Note
Please observe the regional safety and building regulations. Please contact your master chimney sweep in this context.

Note
Only use heat-resistant sealing materials as well as corresponding sealing strips, heat-resistant silicon and rock wool.

Note
Also take care that the flue does not project into the free cross-section of the chimney.

Note
In case of room-air independent operation the stove pipe connections must be tightly sealed permanently. Use a heat-proof silicon to position the stove pipe on the conical supports of the flue tube nozzles and for insertion in the chimney flue lining.

Note
The stove should not be pushed on unprotected floors.

Tip
Strong corrugated cardboard, cardboard or e.g. old carpet is useful to assist assembly and as a base. The stove can also be pushed on this cardboard or carpet.

We recommend original flue pipes from RIKA for proper connection.

Connection to the chimney

- The device must be connected to an approved chimney for solid fuels. The chimney must have a diameter of min. 100mm for pellet stoves and 130mm -150mm for log wood stoves depending on the diameter of the flue pipes.
- Avoid long flue pipes to the chimney. The horizontal length of the flue pipe should not exceed 1.5 m.
- Avoid too many bends of the flue gas pipes. There should not be more than 3 bends in the exhaust pipe.
- If you just can not connect directly to the chimney, please use a connection with a cleaning opening.
- Connections must be made of metal and must meet the requirements of the standard (install the connections airtight).
- Before installing a chimney calculation must be made. The evidence must be performed for single occupancy to EN13384-1 and EN13384-2 for multiple occupancy.
- The maximum draft of the chimney should not exceed 15Pa.
- The derivation of the flue gases must be guaranteed even during a temporary power outage.

Note
If connecting to multiple connection chimneys additional safety equipment is required. Your local chimney sweep will advise you in this case.

Connecting to a steel chimney

The connection must be calculated and shown with EN13384-1 and EN13384-2.

Use only insulated (double) stainless steel tubes (flexible aluminum or steel tubes are not permitted).

An inspection door for regular inspection and cleaning must be present.

The flue pipe connection to the chimney has to be air-tight.

Combustion air

Every combustion process requires oxygen from the surrounding air. This so-called combustion air is removed from the living area in the case of individual stoves without external air connections.

This air removed must be replaced in the living space. Very tightly sealed windows and doors in modern flats may mean that too little air replaces that used. The situation also becomes problematical due to additional venting in flats (e.g. in the kitchen or WC). If you cannot feed in external combustion air, then air the room several times a day to prevent negative pressure in the room or poor combustion.

Feeding in external combustion air

only for devices which are able to run in room-air independent operation.

- Combustion air must be fed to the stove from outside via a sealed pipe for operation independent of the room air. According to EnEV, it must be possible to shut off the combustion air pipe. The open/closed setting must be clearly recognisable.
- Connect at the air intake either a pipe Ø125mm (log wood and combi stoves) or Ø50mm (pellet stoves) and fix it with a hose clamp (not included!). At pellet stoves with longer intake pipes than 1m the diameter should be increased to 100mm. (see RIKA range).
- To ensure sufficient air intake, the intake pipe should not exceed max. 4m and have max. 3 bends.
- If the line leads outside it must have a windbreak.
- In extreme cold pay attention to icing on the air intake opening (check).
- It is also possible to suction in combustion air directly from another sufficiently vented room (e.g. cellar).
- The combustion air pipe must be tightly connected (adhesive or cement) permanently to the air nozzles of the stove.
- If you do not use the stove for a long time, please close the combustion air intake to prevent the stove from moisture.

Note
Please note that problems may arise due to updrafts in the case of combustion air supply from an integrated chimney ventilation shaft. If the combustion air flowing downwards is heated it may rise and thus counter the chimney with a resistance which in turn reduces the negative pressure in the combustion chamber. The chimney manufacturer is to guarantee that the resistance for the combustion air is a maximum 2 Pa even in the least favourable operating state of the chimney.

If one or more of these conditions does NOT apply, the result is poor combustion in the stove and negative pressure in the installation room.

6. ASSEMBLY/DISMANTLING STONE AND OPTIONS

Note

Only work on the unit when the mains plug has been disconnected and the stove has cooled completely.

Note

During assembly / dismantling do not allow objects (screws etc.) to fall into the pellet container – they can block the screw conveyor and damage the stove.

Note

During any conversion work, take particular care of your fingers and any panels and stove attachments.
Select soft bases to prevent scratches to your living space furniture and stove panels.

Disassembly of the front side casing

Remove the convection fins by lifting slightly. The convection fins are only suspended

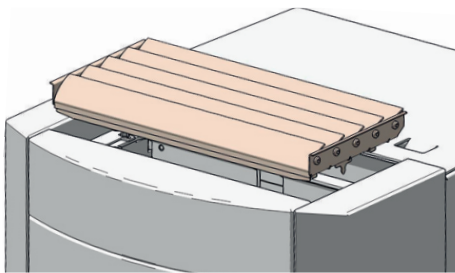

Now remove the upper hexagon screw on the front stone holder and loosen the bottom two.

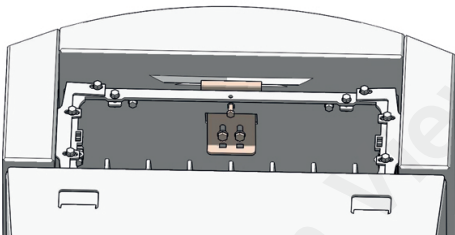

You can now lift the front stone.

Now remove the 8 hexagonal screws used to attach the two side stone holder. You can then remove the side stones

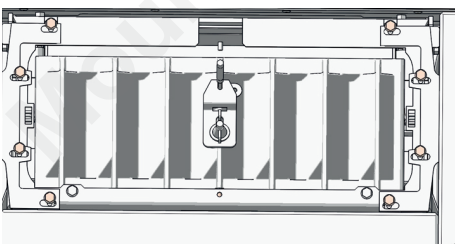

Install the removed parts in reverse order.

Disassembly of the rear side panel

Open the Container lid

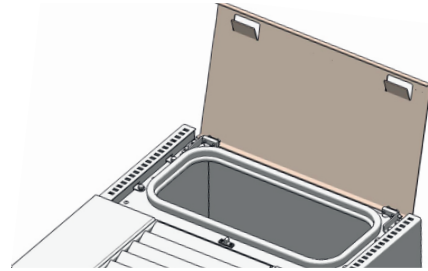

Remove the 2 vertical hexagonal screws used to attach the right rear side panel.

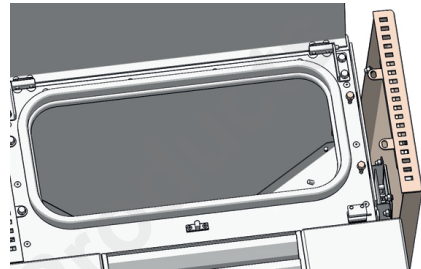

You can now lift the right rear side panel.

Install the removed parts in reverse order.

The disassembly of the left rear side panel is analogous to removing the right rear side panel.

7. INTERNAL CONTROLS

The stove has a modern programmable microprocessor control. The individual unit functions can be preset by the user via the internal controls located in the right casing (keyboard with operating display).

Basics

Note

Manipulation of hardware components may only be performed by trained specialist dealers and service. Incorrect handling of these parts leads to loss of warranty and guarantee claims!

Note

The unit may only be put into operation when assembled completely!

Operation

All settings and functions can be controlled via this unit.

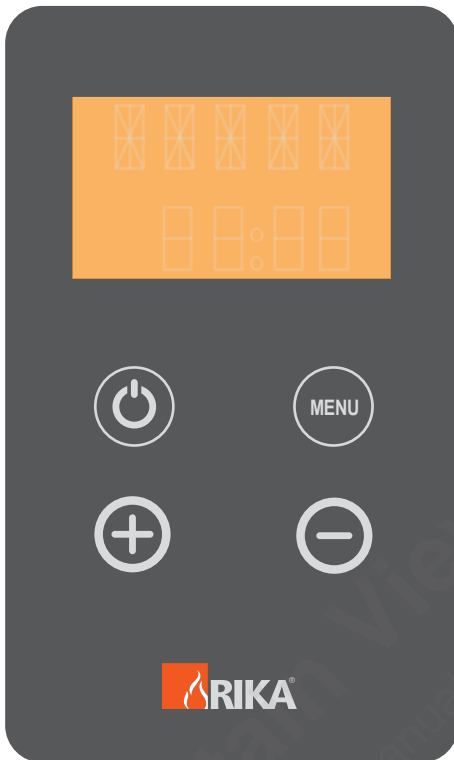

The display is illuminated when touched. After some seconds the display lighting turns off again.

EASY MODE – simple heating operation

Your stove is in simple heating mode EASY OFF when delivered in order to ease your start in the world of RIKA pellet stoves. The heat output of the stove can only be increased or reduced in 5 % increments in this mode. As soon as the stove is connected to the socket, the standard display EASY OFF appears. The message „CHECK“ appears in the display as soon as your pellet stove is connected to the power supply (even after a power failure). The display buttons are disabled for approx. 10 seconds as the stove conducts an initialisation of all components. When „CHECK“ disappears from the display the stove can be started up.

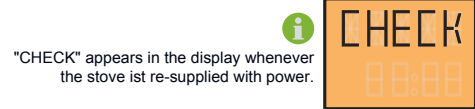

EASY OFF – inactive state

key	display	description
	EASY OFF	Standard display for stove switched off in simple heating mode. The output can also be regulated between 30% and 100% with the stove switched off (EASY 30 – EASY 100).
+	EASY 45	Pressing increases output by 5%
-	EASY 35	Pressing decreases output by 5%

Start – scavenge – tip – ignition

The pellet stove is started in the scavenging phase by pressing the button. The scavenging phase lasts approx. 50 seconds and is used to eliminate any adverse draft conditions in a cold flue. The grate tips automatically during the scavenging process and any ash leftover from the previous combustion phase falls into the ash tray.

Depending on the fill level of the screw conveyor the ignition process can take approx. 5 to 30 minutes until the first flame is visible.



If the first ignition attempt is unsuccessful, further ignition attempts will be initiated automatically. This may occur if the screw conveyor is not completely full during the ignition process (e.g. first start after refilling empty container).

Note

In the event of a false start remove any unburnt pellets and ash from the combustion cavity. Never replace unburned pellets from the fire pot in the supply container.

FIRE HAZARD DUE TO RESIDUAL EMBERS

key	display	description
-----	---------	-------------

	EASY OFF	
	IGNIT	Pressing  starts the unit.
	START	This is shown by IGNITE in the display; this is replaced by START after a brief time.
	EASY 35	EASY xx appears in the display after the start phase (xx stands for a value between 30% and 100%, depending on output)

Cleaning and tipping during operation

The automatic cleaning process is conducted every hour for approx. 2 minutes. During this phase the air vents that are necessary for combustion are blown clean.

Great cleaning phase (only stoves with automatic turning grid):

The pellet stove enters the burnout phase every 7 hours. A tipping process is conducted automatically. The start-up phase is automatically re-initiated after completion of the burnout phase and operation continues

EASY 40 – switch off

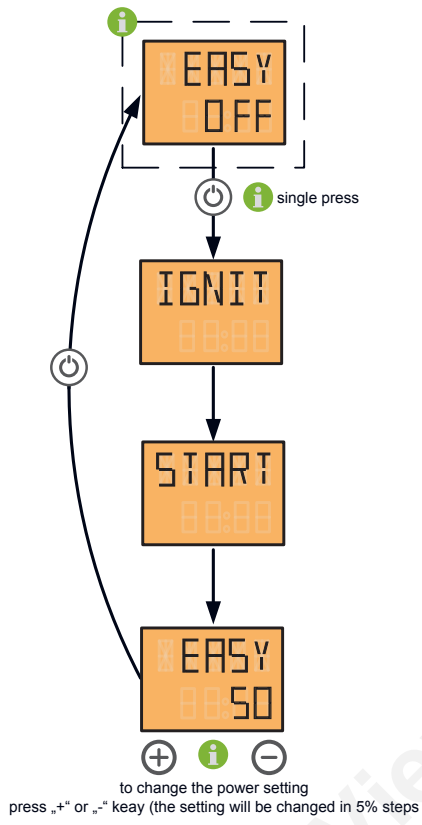



 STOP
EASY OFF

The burnout phase is initiated by pressing for at least 2 seconds (until the change is visible on the display). The pellet support stops - the flue gas fan continues to burn any pellet residues (approximately 10 minutes).

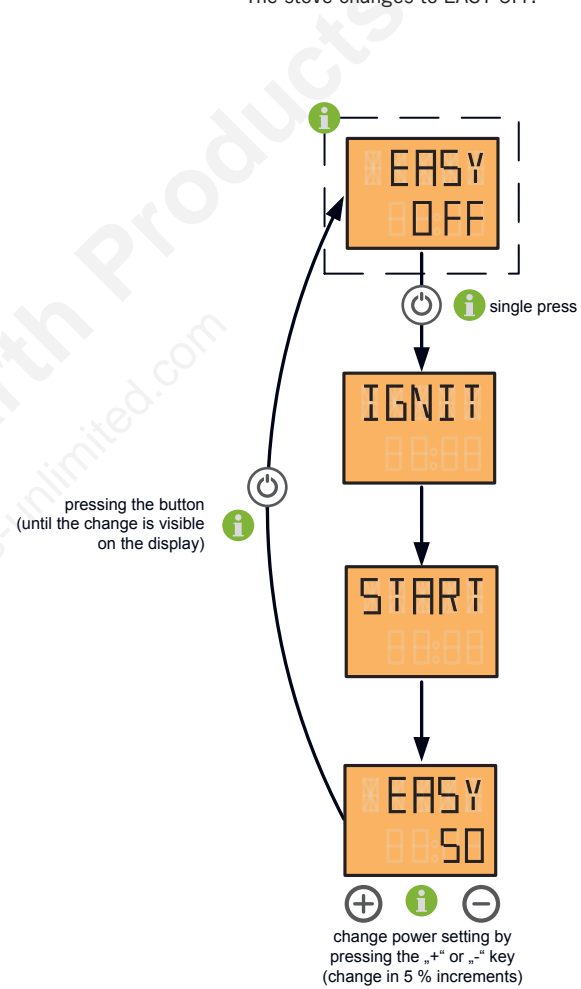
The stove changes to EASY OFF.





Stopping during ignit or startphase

If switching off occurs again 50 sec. within switching on (-key) (at least 2 sec. -key), the pellet stove returns to inactive status.

If switching off occurs during the ignition process (IGNIT or START) (at least 2 sec. -key), IGNIT OFF or START OFF appears in the display and the burn-out phase is initiated. The pellet support stops - the flue gas fan continues to burn any pellet residues (approximately 10 minutes). The stove changes to EASY OFF.

EASY 40 – operation

key	display	description
-----	---------	-------------

	EASY 40	Standard display for stove switched on in simple heating mode. (40 is the output in %)
	EASY 45	Pressing increases output by 5%
	EASY 40	Pressing decreases output by 5%

Extended heating operation - HEAT MODE - comfort functions

In addition to the basic functions of simple heating operation, the RIKA pellet stove provides extra comfort functions. However, before you can use the comfort functions such as frost protection, installation of an external room thermostat, regulation of the stove mobile telephone, child safety device, you have to change from simple heating to comfort mode.

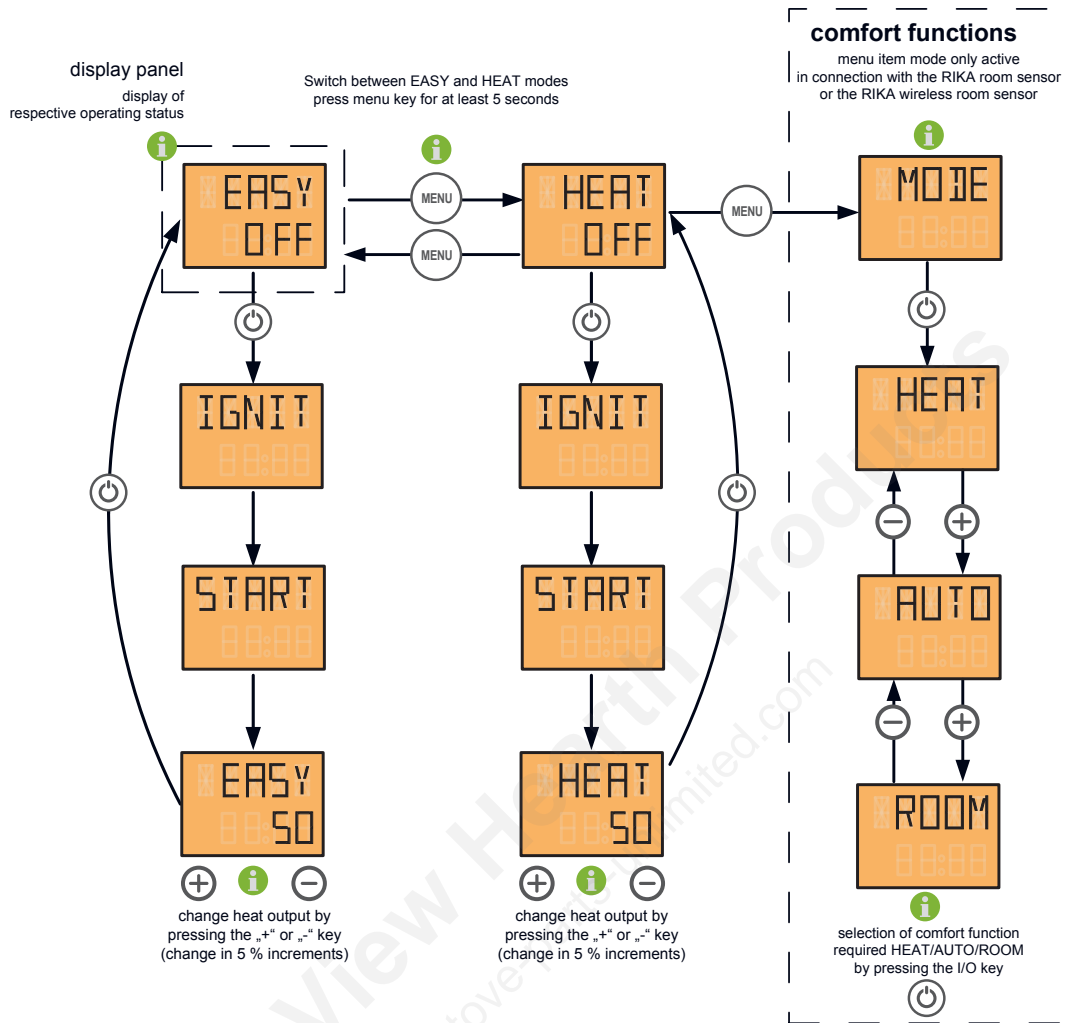

EASY OFF Standard display for stove switched off in simple heating mode.

MENU Pressing for at least 5 seconds changes to HEAT mode. The change is also shown in the display as confirmation.

HEAT OFF Standard display for stove switched off in extended heating mode. (comfort functions can now be selected)

MENU Pressing once changes to display MODE

MODE You can select one of three possible stove comfort functions. (the menu item Mode is only active in connection with the RIKA room sensor or the RIKA wireless room sensor active).

Power Pressing once takes you to the comfort function selection and you can change between the individual comfort functions using keys **+** and **-**.

HEAT



AUTO

Pressing again confirms the comfort function currently visible HEAT, AUTO or ROOM.

ROOM

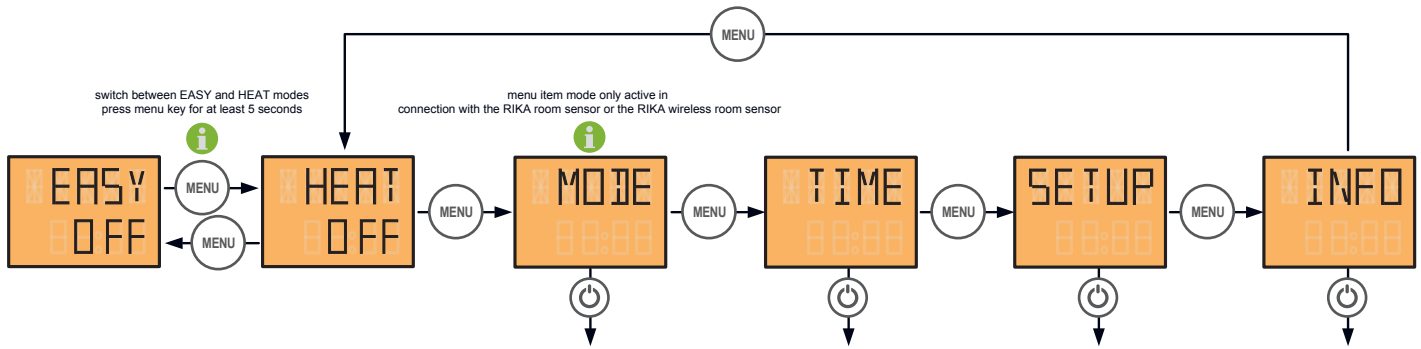

EASY OFF Standard display for stove switched off in simple heating mode.

Pressing for at least 5 seconds changes to HEAT mode. The change is also shown in the display as confirmation.

HEAT OFF Standard display for stove switched off in extended heating mode.

Pressing once changes to display MODE

MODE You can select one of three possible stove comfort functions. (The menu item Mode is only active in connection with the GSM option, the RIKA room sensor and/or the RIKA wireless room sensor active, also see “Extended heating operation – comfort functions”).

Pressing once changes to display TIME

TIME Setting regarding the time are made here. (Heating time is only available with RIKA room sensor or RIKA wireless room sensor).

Pressing once changes to display SETUP

SETUP All the additional functions can be regulated here.

Pressing once changes to display INFO

INFO Access to information menu, various system parameters, temperatures and operating information can be called up here.

Pressing once changes to display HEAT OFF

HEAT OFF Standard display for stove switched off in extended heating mode.

Pressing for at least 5 seconds changes to EASY mode. The change is also shown in the display as confirmation.









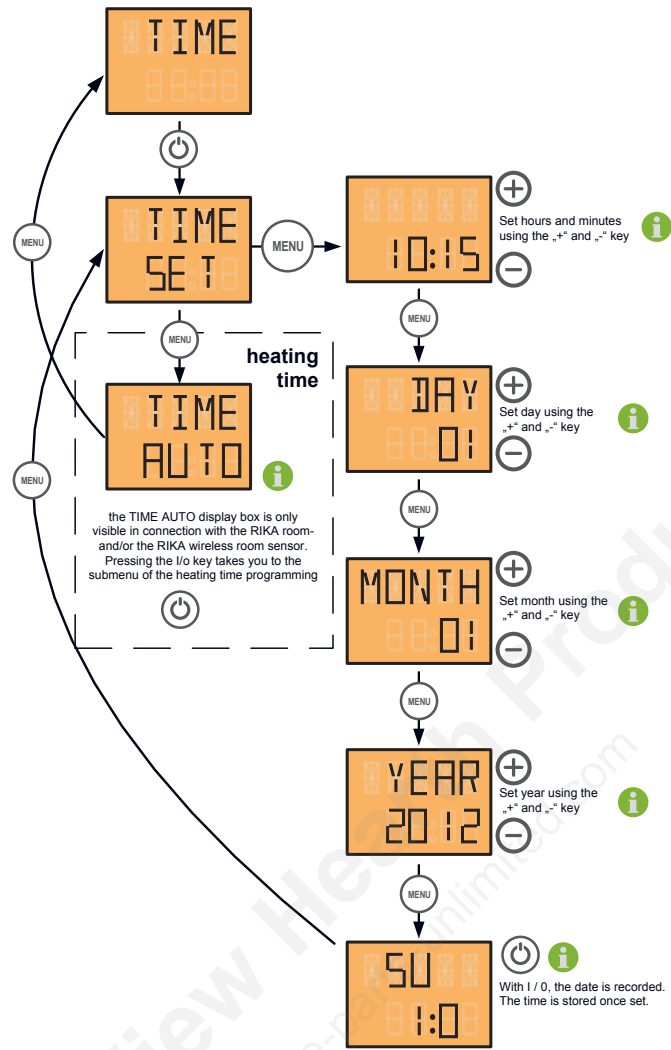









EASY OFF Standard display for stove switched off in simple heating mode.

Pressing once on the respective main menu items MODE, TIME, SETUP and INFO selects the submenu items.

The individual main menu items TIME, SETUP and INFO are explained in more detail on the next pages.

The menu navigation described above remains the same during operation. The respective heat output set is shown in the display instead of EASY OFF or HEAT OFF. For example EASY 30 or HEAT 30



	TIME	Display to enter the control level for time adjustment.
	TIME SET	All the settings concerning time, date and heating time (optional) are made here.
	00:00	Setting the time. Hour display is changed using  , minute display using  .
	DAY 01	Setting the day. Display is changed using  and  .
	MONTH 01	Setting the month. Display is changed using  and  .
	YEAR 2012	Setting the year. Display is changed using  and  .
	SU 1:0	The actual day is shown in the display as confirmation.
	TIME SET	Back to TIME SET.
	(TIME AUTO)	(Setting the heating times. The menu item TIME AUTO only appears in connection with the RIKA room sensor and the RIKA wireless room sensor). (Please see the operating instruction enclosed for the option for setting the heating times).
	TIME	Back to TIME.
		Repeated pressing returns you to the main menu level.









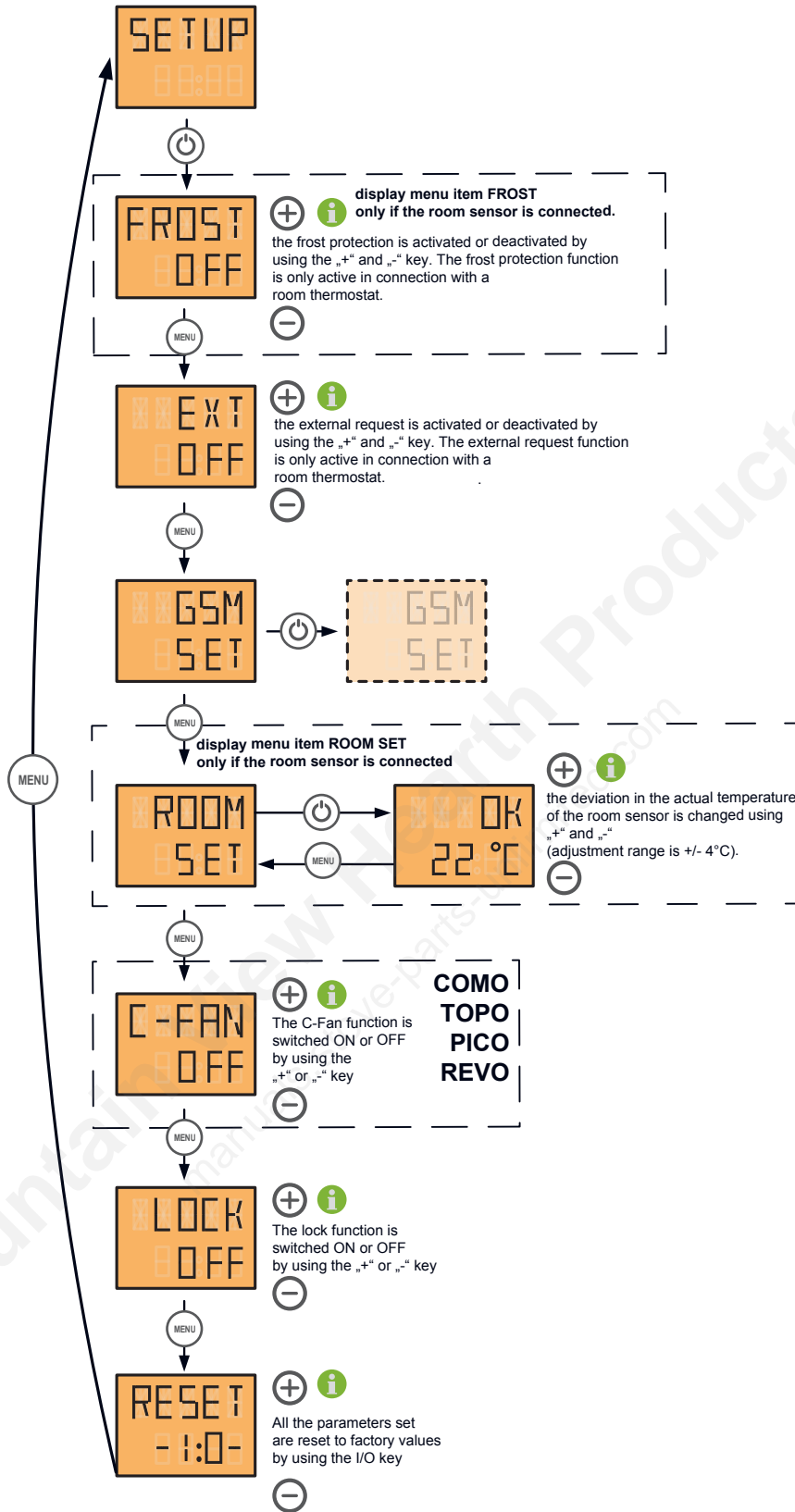













Note

Summer- and wintertime is not changed automatically



Mountain View Hearth Products
manuals.stove-parts-unlimited.com



	SETUP	Display to enter the control level for additional functions. You can change between the operating status On (active) and OFF (inactive).
	FROST OFF	Display of operating status of additional function FROST, frost protection (only in connection with RIKA room sensor and RIKA wireless room sensor). Using  and  you can switch between FROST OFF (inactive) and FROST ON (active). Frost protection is only active in combination with the comfort functions HEAT OFF, ROOM OFF and AUTO OFF. Starting temperature 8°C, stopping temperature 13°C
	EXT OFF	Display of operating status of additional function EXT external unit such as e.g. a customary room thermostat (see Comfort function – external room thermostat for more information). Using  and  you can switch between EXT OFF (inactive) and EXT ON (active)..
	GSM SET	All settings concerning Telephone option – GSM are made here. Pressing  takes you to the submenu of Telephone option – GSM. Please see the operating instructions accompanying the Telephone option – GSM for settings.
	ROOM SET	The room temperature displayed may deviate from the actual temperature and therefore the sensor may be calibrated by +/- 4°C. Thus the actual temperature of the room sensor can be adjusted e.g. to the house thermometer.
	C-FAN OFF	Display of the operating status of the optional cross-flow fan. You can switch between C-FAN OFF (inactive) and C-FAN ON (active) by pressing  and  .
	LOCK OFF	Display of operating status of additional function LOCK child safety device (key lock). Using  and  you can switch between LOCK OFF (inactive) and LOCK ON (active). To lock the keyboard with active child protection device (LOCK ON), press  and  at the same time for at least 5 seconds in the standard mode EASY or HEAT. LOCK appears in the display as confirmation. To unlock the keyboard again press  and  at the same time for at least 5 seconds. LOCK OFF appears in the display as confirmation.
	RESET - 1:0 -	Any settings changed can be reset to the delivery status here. Pressing  resets the stove to the factory settings.
	SETUP	Display to enter the control level for additional functions. You can change between the operating status On (active) and OFF (inactive).
		Repeated pressing returns you to the main menu level.

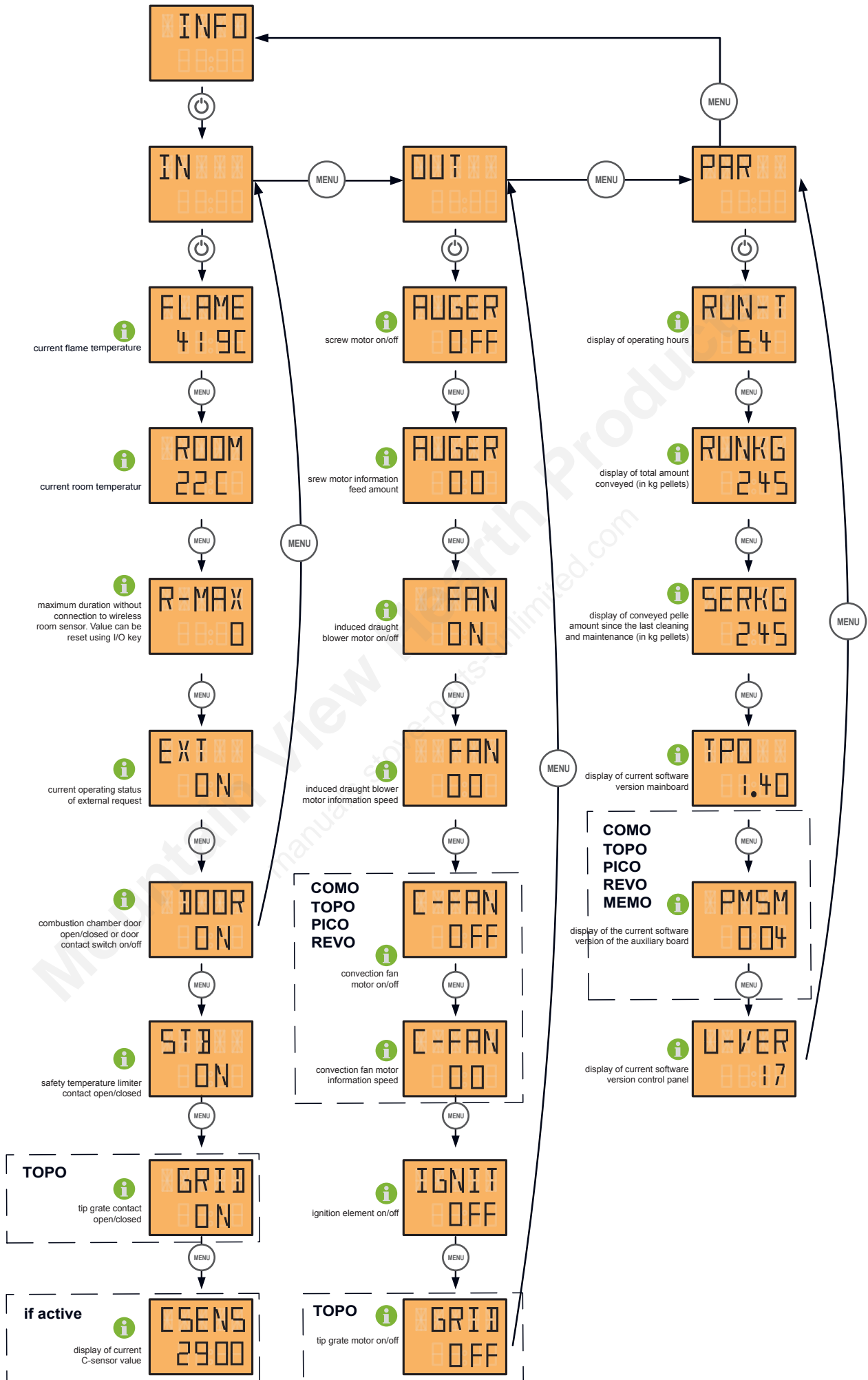

	INFO	Access to information menu, various system statuses, temperatures and operating information can be called up here.
	IN	INFORMATION INPUTS
	FLAME 319	Display of current flame temperature
	ROOM 22	Display of current room temperature
	R-MAX	Display menu maximum duration without connection to wireless room sensor
	EXTON	Display of status of external release (ON or OFF)
	DOOR ON	Display of the status of door contact (ON or OFF)
	STB ON	Display of the status of safety temperature limiter (ON or OFF)
	GRID ON	Status display for the mudhole door contact (ON or OFF)
	IN	INFORMATION INPUTS
	OUT	INFORMATION OUTPUTS
	AUGER OFF	Display of operating status of screw motor (ON or OFF)
	AUGER 0	Display of actual push-in rate
	FAN ON	Display of operating status of flue gas blower (ON or OFF)
	FAN 0	Display of speed of flue gas blower
	C-FAN OFF	Display of the operating status of the optional cross-flow fan (ON or OFF)
	C-FAN 0	Display of the speed of the cross-flow fan
	GRID OFF	Display of the operating status of the mudhole door motor (ON or OFF)
	IGNIT OFF	Display of operating status of ignition element (ON or OFF)
	OUT	INFORMATION OUTPUTS
	PAR	INFORMATION PARAMETER
	RUN - T 63	Display of previous total operating hours
	RUNKG 245	Display of total pellet amount supplied up to present
	SERKG 245	Display of conveyed pellet amount since the last cleaning and maintenance
	TPO 0144	Display of current software version loaded on control board (Scrolling text)
	PMSM-VER 004	Display of the current software version of the auxiliary board (Scrolling text)
	U-VER 17	Display of current software version loaded on control unit
	PAR	Repeated pressing returns you to the main menu level.

8. COMFORT OPTIONS

We would point out that auxiliary units may only be connected to the RIKA interface connection and external connection socket by authorised specialists.

RIKA room sensor/RIKA radio room sensor

This option permits control of your stove via room temperature. You can set both the room temperature and the heating times required. A room temperature selected by you is observed during the heating times.

Please see the operating instructions for the option RIKA room sensor and wireless room sensor for more detailed information.

RIKA phone option – GSM

Your stove can also be controlled via a mobile phone as an additional option.

Please see the operating instructions for the telephone option – GSM for more detailed information.

RIKA interface for various options

for various options

The RIKA ROOM SENSOR, the RIKA WIRELESS ROOM SENSOR and the RIKA PHONE OPTION – GSM are to be connected to the interface (stove rear) using the connection cable supplied.

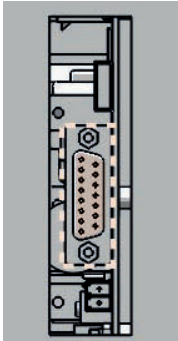

External room thermostat

Your stove has an interface on the rear wall to which you can connect a customary room thermostat. This requires a 2-pole cable of 0.5 – 0.75 mm² cross-section that you have to connect instead of the cable bridge fitted for delivery

External connection cable bridge

(condition as delivered)

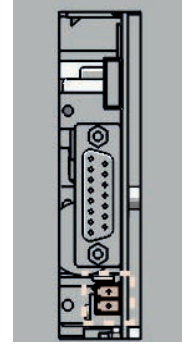

The stove settings in the menu item Setup are to be checked to ensure the function of the room thermostat. The external unit must be set to EXT ON (active) as described above.

This function enables you to deactivate a connected room thermostat (setting EXT OFF).

All further settings required to your thermostat can be taken from the room thermostat operating instructions.

The connected room thermostat must be operated in the HEAT menu. You can select the heat output you wish for the room temperature selected.

If an external demand for stopping the pellet stove occurs, it takes about 5 minutes until the pellet stove switches to burn out phase.

Note

Operation is not possible unless either a cable bridge or an external room thermostat is connected. The external demand has priority over all operating modes (EASY/HEAT/AUTOMATIC/ROOM).



9. MODES

Note

When operated correctly, your stove can not overheat. Improper operation may shorten the life expectancy of electrical components (blowers, motors and electric control) and is not allowed!

Pellet operation Heat/Easy/Automatic/Room

HEAT/EASY

The pellet burner start and stop as well as the setting of the required heat output are executed directly in the HOME – main menu.

AUTOMATIC MODE

The change between standby operation and neutral as well as the setting of the required heat output are executed via the display in the HOME – main menu.

The pellet burner starts in standby mode within the heating times when the actual room temperature is below the set room temperature, or outside of the heating times when the actual room temperature is below the set room temperature.

When achieving the set room temperature, the pellet burner stops.

Stove start is not possible in neutral status (OFF), the system is switched off.

ROOM MODE

The change between standby operation and neutral as well as the setting of the required heat output are executed via the display in the HOME – main menu.

The pellet burner starts in standby mode if the actual room temperature is below the set room temperature.

When achieving the set room temperature, the pellet burner stops.

Stove start is not possible in neutral status (OFF), the system is switched off.

Pellet container refilling during operation

Note

CAUTION when filling! Avoid direct contact between the plastic bag and the hot stove. Immediately remove all pellets that have fallen on the hot stove or next to the container!

We recommend always having a suitable amount of pellets in the container to prevent the fire from extinguishing due to a lack of fuel. Check the level frequently. However the container lid should be kept closed, except during filling.

If you refill the container during operation (open the container lid), the fan will speed up and the pellet auger will stop; operation will only be continued once the container lid is closed again (see WARNING AND ERROR MESSAGES)

Pellet container capacity (see Technical Data).

Emergency operation – heating up without electrical Ignition

If the ignition cartridge fail, firelighters can be used for an emergency operation. First, start the stove as usual. Wait for the turning of the grid (only for units with turning grids). Then open the combustion chamber door and give a handful of pellets with the firelighter into the clean burn pot, light it up and close the combustion chamber door.

Note

Do not use flammable liquids to light up the fire!

10. MENU OVERVIEW V1.40

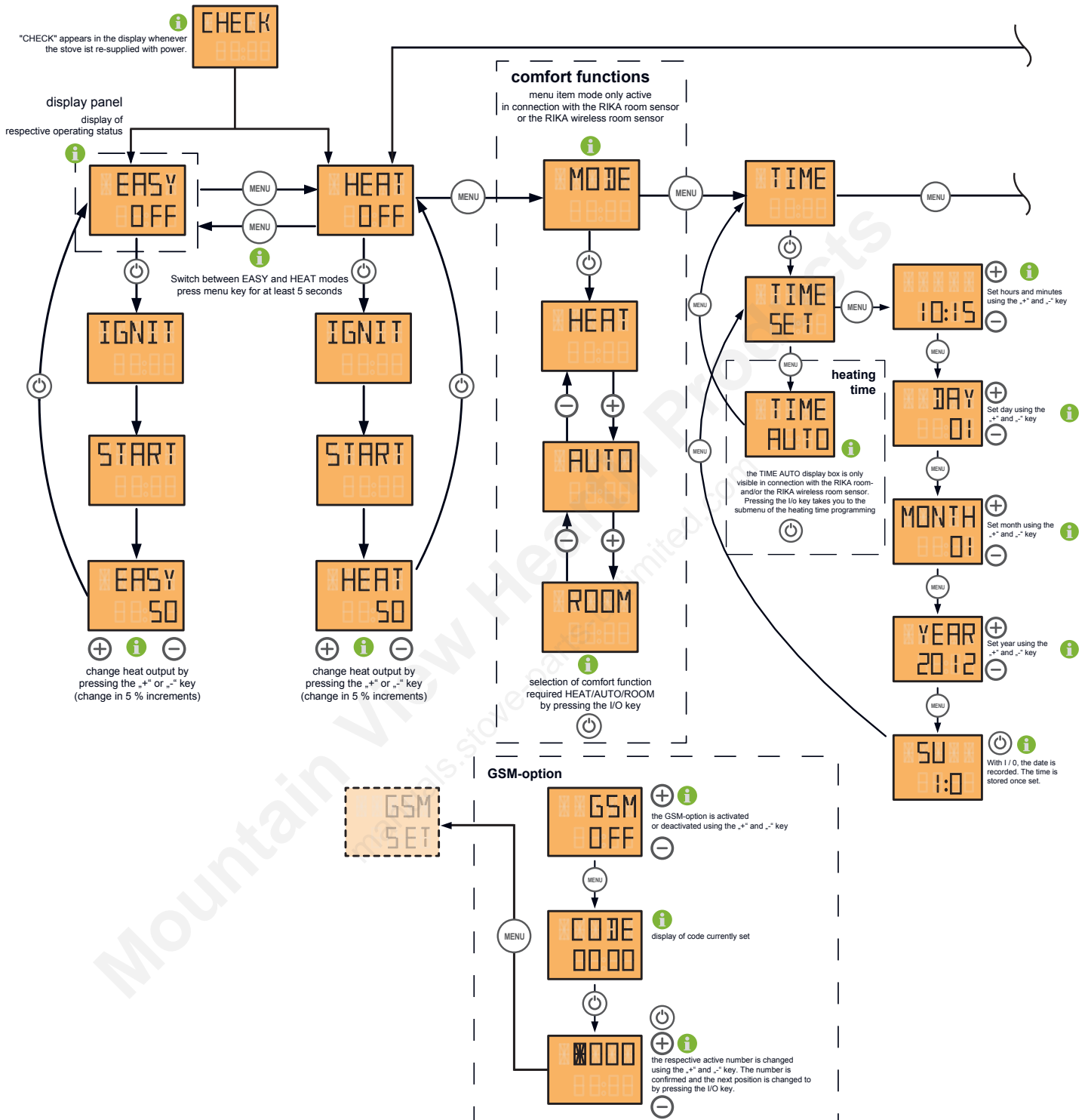

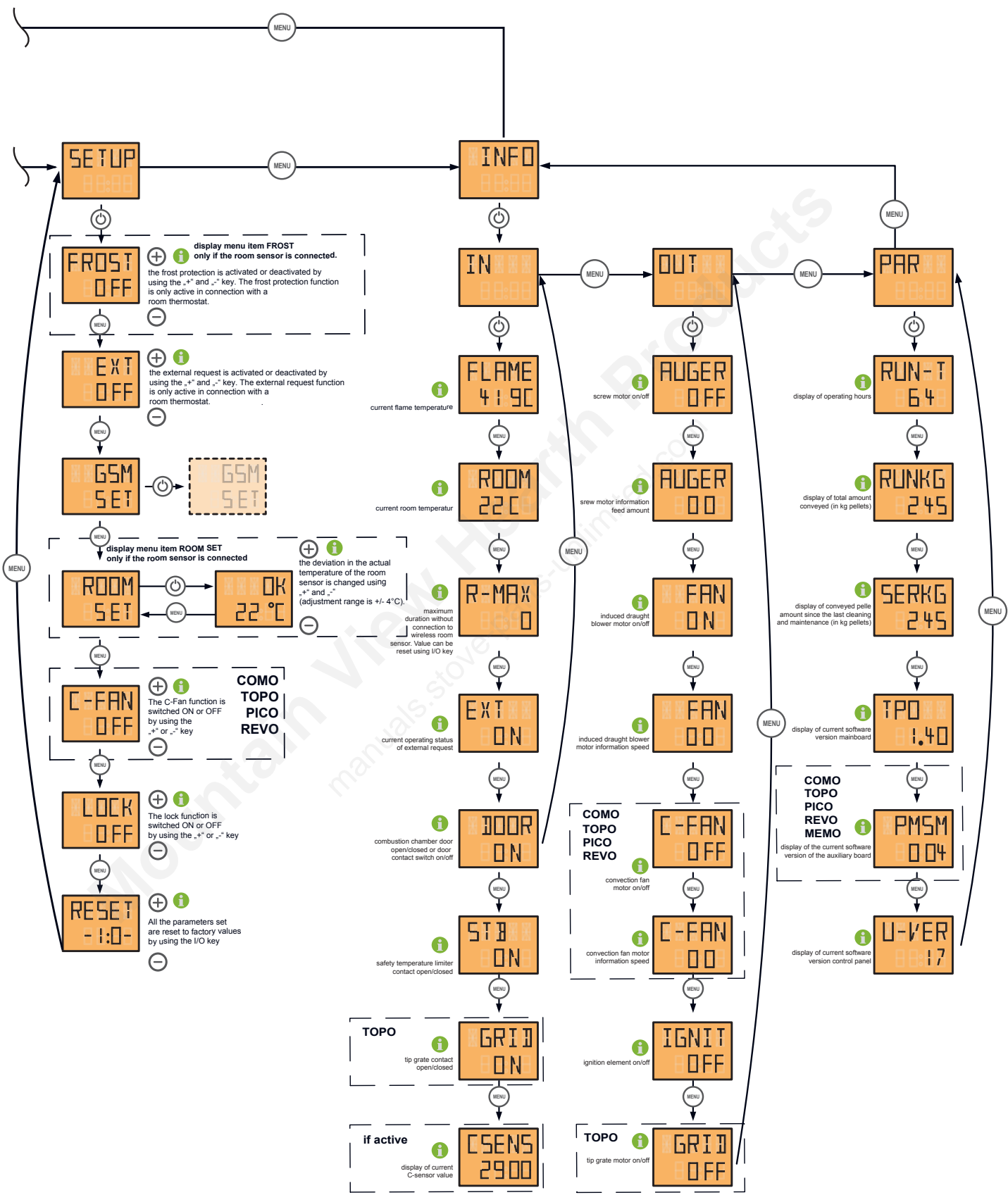

11. WARNINGS AND ERROR MESSAGES



If a malfunction occurs, the main menu is switched to and the malfunction is displayed in marquee. The malfunction is acknowledged by pressing  for at least 2 seconds.

The button must be depressed until the change in the operating status appears on the display.

Note

If error messages recur directly, customer service is to be notified immediately. In the case of error messages that pose a safety risk, burnback and flue gas flap is activated and the stove is automatically switched off



Display	Malfunction designation	Cause / remedy
STB >I/O<	Safety temperature limiter is activated	Establish cause of activation; eliminate this and reset using reset button directly at STB. The error message must then also be acknowledged. Only with cooled stove.
NO PELLETS >I/O<	No pellets in container	May also occur on first start (first filling). Check whether there are sufficient pellets in the container and re-start unit after acknowledging malfunction. - Screw conveyor blocked - Flame sensor sleeve dirty - Chimney draught too great
FAN DEFECT >I/O<	Flue gas blower defective	Acknowledge the error message.
FLAME SENSOR DEFECT >I/O<	Flame sensor defective	Acknowledge the error message.
ROOM SENSOR SIGNAL LOST >I/O<	Rika room sensor reception defective	Transmission between the transmitter and receiver has been lost. If the error message appears again immediately after re-starting the device, it means either the battery is flat or the component is defective.
SERVICE >I/O<	Pellet amount for cleaning and maintenance exceeded	Acknowledge the message and perform cleaning or maintenance procedures (see CLEANING AND MAINTENANCE).
CALL SERVICE MOTOR	Pellet backlog	Overfilling of the combustion cavity with a subsequent backlog of pellets in the drop chute has been detected. Remove any encrustations in the burn pot. The error message can be acknowledged by pressing the  and  button simultaneously (held until the error message disappears).
DOOR OPEN >I/O<	Door open	Check to make sure the door is closed and that the door contact switch engages. (The DOOR OPEN message doesn't need to be acknowledged; the display will disappear when the door is closed.)
AUGER-PMSM DEFECT >I/O<	Screw motor defective	Acknowledge the error message.

12. CLEANING AND MAINTENANCE

Basic information

Note

Your stove must be switched off and cooled before any maintenance work is performed. Ensure that you do not vacuum into the combustion air line during heating operation during any cleaning (vacuuming). You could vacuum out embers – FIRE RISK!

Note

SERVICE appears in the display after consumption of 700 kg pellets. Cleaning and maintenance is to be performed. This message can be acknowledged by pressing ENTER and operation can be continued. The number of SERVICE messages is stored in the background.

Note

Only work on the unit when the mains plug has been disconnected.

The frequency with which the stove requires cleaning and the maintenance intervals depend on the fuel you use. High moisture content, ash, dust and chips may more than double the maintenance required. We would like to again point out that only tested and recommended pellets or logs may be used as fuel.

Tip

wood as fertiliser - The mineral content of the wood remains in the combustion chamber as ash as a residue of the combustion. This is an excellent fertiliser for all plants in the garden; it is a completely natural product. The ash should be stored first and extinguished with water.

Note

Ash may contain embers – only place ash in sheet steel containers.

Open the combustion chamber door

To open or close the combustion chamber door use the included key. This key can also be stored on the back of the stove.

Cleaning of the burn pot - daily

Make sure that the air vents are not blocked with ash or clinker. Remove the clinker using the supplied wire brush and vacuum the burn pot.



Do not damage the ignition when cleaning with a wire brush.

Note

Clean the fire trough regularly. Only clean when cold, when embers are extinguished!

Note

If the stove is heated in continuous operation, it must be cleaned 2x within 24 hours. BACK FIRE HAZARD!

Empty the ash drawer

Empty the ash drawer regularly. The ash drawer is simply pulled forward with the combustion chamber door open

Cleaning flue pipes

Remove the convection fins by lifting slightly. The convection fins are only suspended.

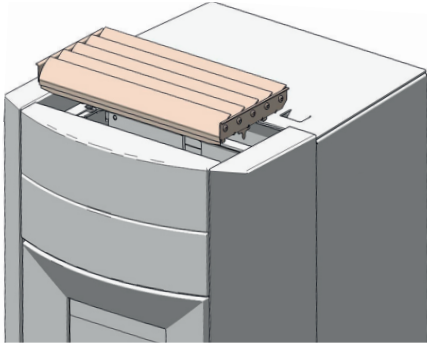

Open the screw of the sensor tube with an open end wrench #19 and remove the flame temperature sensor and the sensor tube.

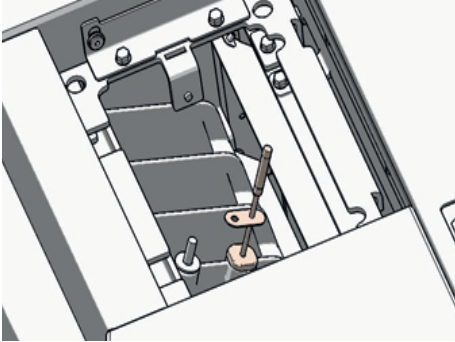

Open and remove the wing nut, which serves to secure the firebox lid. For ease of disassembly, you should hold against the screw through the combustion chamber.

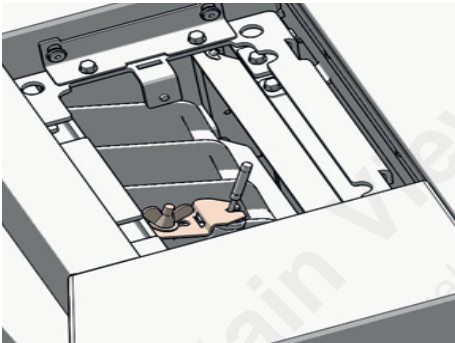

You can now lift off the combustion chamber lid.

Now clean the flue gas passes on the left and right of the combustion chamber with the supplied wire brush.

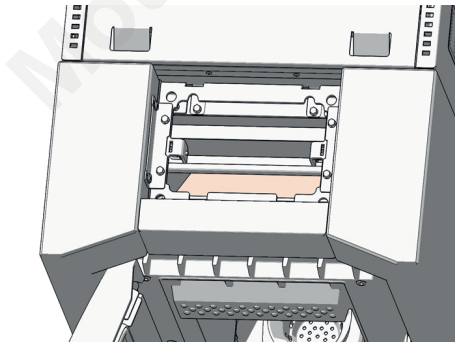

Suck free the exposed interior and the side passages of impurities.

Install the removed parts in reverse order again.

Clean flue gas collecting channel

Open the firebox door.

Loosen the two hex head screws and remove the lower front panel.

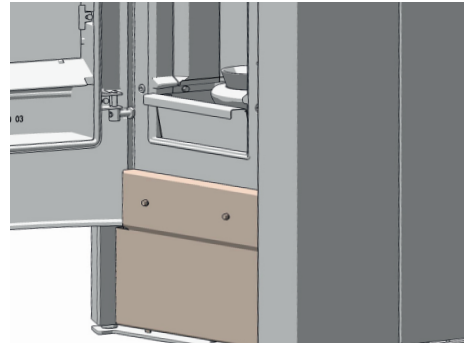

Remove the cover plate by opening the two outer hexagon screw.

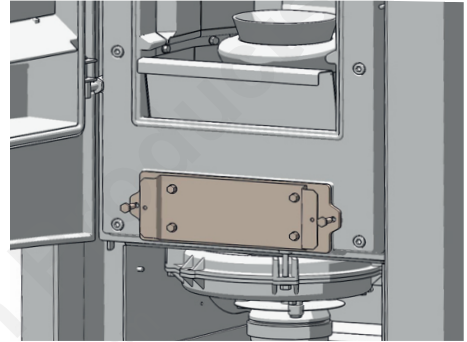

Suck out the combustion residues from the flue gas collection channel.

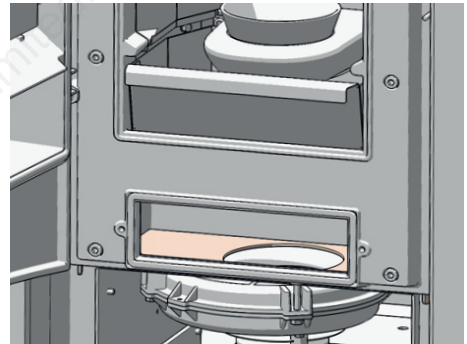

Install the removed parts in reverse order.

Note

If the seals of the cleaning cover are not properly sealed, it is possible that the heater gets "wrong air", causing incomplete combustion in the grate and then an accumulation of pellets



Clean flue gas fan housing

The flue gas fan and the flue pipe connection should be cleaned at least 2 times a year, or after about 700 kg of pellets.

To inspect and clean the flue gas fan, the back wall has to be removed.

The four screws that secure the flue gas fan motor have to be opened and the motor is carefully pulled out of the case.

Remove with a vacuum cleaner the ash from the fan and flue gas pipes. When closing again definitely pay attention to leaks.

For cleaning the flue pipe connection, pull the flue pipe from the flue gas fan and suck out the blower housing.

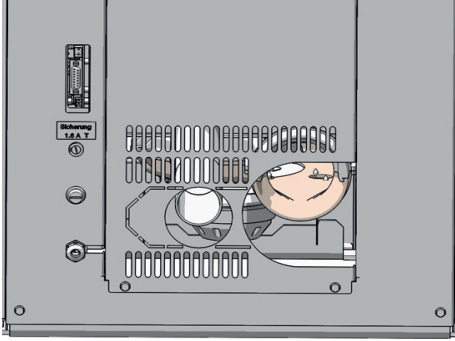

Checking door seal

The condition of the seals at doors and glass should be checked at least 1 x per year. Repair or replace seals depending on condition.

Note

Only intact seals ensure your stove works perfectly.



EN

Cleaning of painted surfaces

Wipe of the painted surfaces with a damp cloth, do not scrub. Do not use solvent-containing cleaners.

Cleaning the flue gas channels

(1 x annually)

Remove the flue pipes. Inspect and clean chimney connection. Brush off any soot and dust deposits in the fire and in the flue pipes and vacuum.

Note

Accumulated fly ash in the flue gas channels may impair the performance of the stove and pose a safety risk.



Cleaning the flame temperature sensor

Remove the dust deposits from the sensor at regular intervals. Use a clean cleaning cloth or newspaper.

Cleaning the pellet container

Do not refill the completely empty container immediately; remove the residues (dust, chippings etc.) from the empty container. The unit must be disconnected from the mains!

Cleaning the door glass

The viewing window becomes coated in the case of solid fuels, particularly with the very fine ash of wood pellets, light or dark depending on the pellet quality (especially with low output). The glass can be cleaned best with a moist cloth. Stubborn dirt can be removed with a special cleaner available from your stove dealer.

Bearings

all built in bearings (Pellet screw or turning Grid) should be checked and cleaned according to the condition or replaced min. once per Year.

13. PROBLEMS - POSSIBLE SOLUTIONS

Problem 1

Fire burns with weak, orange flame. Pellets heap up in fire trough, window soots up.

Cause(s)

- Insufficient combustion air
- Poor chimney draught
- Stove is sooted over inside

Possible solutions

- Remove any ash or clinker from the fire trough that may block the air inlets. (see CLEANING and MAINTENANCE)
- If possible swap to better pellet quality.
- Check whether flue gas pipes are blocked with ash (see CLEANING and MAINTENANCE).
- Check whether the air intake or flue tubes are blocked.
- Check door and cleaning cover seals for leaks (see CLEANING and MAINTENANCE)
- Clean fan (see CLEANING and MAINTENANCE)
- Have service performed by authorised specialist company.
- The window has to be cleaned from time to time (see CLEANING and MAINTENANCE)

Problem 2

Stove smells strongly and smokes outside.

Cause(s)

- Burning-in phase (taking into service)
- Stove has accumulated dust and/or dirt

Possible solutions

- Wait to end of burning-in phase and vent the room sufficiently.
- Vacuum off any dust deposits from the convection air openings at regular intervals

Problem 3

Flue gas discharge when wood is added and during heating phase.

Cause(s)

- Leaking cleaning openings
- Chimney draught too low
- Leaking flue pipe connection

Possible solutions

- Check seals and replace (fire door, cleaning lid, ..)
- Check chimney
- Check connections and if necessary re-seal

Note

Please note that checks on the control system and wiring may only be performed in unit switched dead. Any repairs may only be performed by trained specialists.

Tip

If a malfunction message occurs, the cause must first be remedied; the unit can be put back into operation by acknowledging the malfunction at the internal unit.

14. INSTRUCTIONS FOR COMMISSIONING PROTOCOL

FOR PELLET AND COMBI STOVES

The commissioning protocol is to be treated as a document and serves as the basis for the warranty and guarantee terms. It is to be completed entirely, in particular the stove data and addresses, the work to be performed is to be ticked off after completion. The signatories confirm with their signatures that all the items on the list have been concluded properly.

Note

Please return 1 completed protocol for putting into service to RIKA Innovative Ofentechnik GmbH, Müllerviertel 20, 4563 Micheldorf, Austria.

Electrical periphery

It is important that the connection socket in the electrical periphery is earthed. The operability of any room thermostat present must be checked. The execution of commands is to be established by phoning in the case of a GSM modem.

Exhaust gas system

The exhaust line, stove and combustion air inlet are part of the combustion system as a whole; therefore the correct execution must also be checked. The plug connections should be tight in general since the system works with excess pressure. The exhaust tube has a diameter of 100mm for pellet stove, and of 150 mm for the combi stove, which is sufficient for short distances. In the case of several changes in direction, the resistance of the exhaust system can increase with the flue to such an extent that the combustion quality suffers and/or noise arises from the greater flow speed. Correct determination of the chimney draught can only be performed at nominal thermal output and serves to evaluate the chimney. If the draught is more than 15 Pa, then a draught limiter should be installed.

Stove functions

These are the basic stove functions that are to be checked and ticked off. The stove is ready for operation if these functions are ensured.

Operator instruction

This is one of the most important points in the putting into operation. It is very important that the operator understands the stove properly and is prepared to assume responsibility for the basic tasks required for operational safety.

In particular the connection between special features of a biomass heating system and his obligations as well as the warranty and guarantee terms must be explained. e.g. non-tested pellets and screw blockers, lack of cleaning or maintenance and stove malfunctions. Thorough instruction can prevent many complaints.

Stove functions

Explanation of the processes in the stove during ignition, normal operation, cleaning phase etc.

Control

Explain operator's possibilities to intervene, empty pellet container, room thermostat, GSM modem, functions and settings, program times if necessary. Operating instructions: Handover and reference to the content to the following points, is a document.

Warranty terms

Difference between warranty (statutory) and guarantee (voluntary), terms of guarantee, determination of wearing parts, reference to pellet quality to be used and the consequences of poor quality.

Cleaning instructions

Ash and dust occurs with a biomass heating unit. The fire trough is to be cleaned regularly with regular heating operation (in the case of pellet operation, the drilled air holes in particular must be free of residues). The ash drawer is to be emptied regularly. The flue gas pipes are to be cleaned once or twice in the heating season depending on stove type; by a specialist company is best.

Maintenance

Maintenance work after defined burn-off output is to be performed by specialist company, including thorough cleaning.

Combustion

All doors must close tightly to prevent intake of false air.

**Note**

Please contact your warranty partner for any warranty questions or claims. This is your dealer or installation company. No warranty claims can be accepted without proper putting into operation, proper operation according to the operating instructions and the supplements in this information sheet.

Protocol for putting into operation for RIKA pellet and combi stoves

Date: _____

Installation address	Dealer
Name: _____	Name: _____
Street: _____	Street: _____
City: _____	City: _____
Telephone: _____	Telephone: _____

Stove data

Stove type:	Casing undamaged
Serial number:	Operating instructions
Software version:	Warranty documents
Touchdisplay version:	Door opener

Electrical periphery

Connection socket earthed	GSM modem present
Room thermostat present	Function checked

Check of system components

Combustion chamber door seal checked	Ease of movement burnback flap checked (combi)
Ease of movement flue gas flap checked (combi)	

Exhaust line / chimney

Diameter	Connection leakproof
Bends	Chimney draught

Stove functions

Pellet container filled	Grid turns (360°) und keeps in heating position
Tested pellet quality according to Önorm/DIN plus/ENplus-A1	Ignition element glows
Electrical connections made	Screw motors run
Safety flaps tightened (combi)	Do pellets fall into the combustion chamber?
Induced draught blower runs	Ignition performed
Stove was switched off when handed over	

Operator instruction

Stove function	Warranty terms
Control	Cleaning
Operating instructions	Cleaning or maintenance interval

*work performed correctly according to order placed*_____
Technician:_____
Operator_____
Client

Company: _____

15. WARRANTY

These warranty conditions are only valid for the following countries: Austria, Germany and Switzerland. Separate conditions imposed by the importer apply for all other countries. In case of doubt as well as missing or incorrect translations, the German version is the only valid one.

For the purpose of timely damage limitation the claimant is required to file the warranty claim with the RIKA dealer in writing, submitting the invoice and stating the purchase date, model name, serial number and reason for complaint.

Warranty

5 years on the welded stove body. This exclusively applies to defects in materials and workmanship as well as free replacement. Labour and travel times are not included in the manufacturer's warranty.

Only original parts supplied by the manufacturer should be used. Loss of warranty on non-observance!

The precondition for the warranty is that the stove has been installed and commissioned properly according to the User and installation manuals valid at the time of purchase. Connection must be performed by a specialist for such stoves.

Any costs incurred by the manufacturer due to unjustified warranty claims are to be charged to the claimant.

Wear parts and parts affected by fire are excluded, such as glass, coating, surface coatings (e.g. handles, panels), seals, fire trough, grates, draught plates, deflector plates, combustion chamber liners (e.g. fireclay), ceramics, natural stone, thermo stone, ignition elements, sensors, combustion chamber sensors and temperature controller.

Also excluded from this warranty are all damages arising from non-observance of the manufacturer's operating instructions of the unit, or damage caused by overheating, use of nonapproved fuels, unauthorised tampering with the appliance or the flue gas pipe, electrical excess voltage, an incorrect, insufficient or excessive flue draught, condensation, non-performance or deficient maintenance and cleaning, nonobservance of the relevant and applicable building regulations, incorrect operation by the user or third parties, as well as any transport and handling damage.

This manufacturer's warranty does not affect the statutory warranty provisions.

02.12.2015



Technical and design changes, as well as typesetting and printing errors reserved

© 2017 | RIKA Innovative Ofentechnik GmbH

Mountain View Hearth Products
manuals.stove-parts-unlimited.com

Z35484_EN_Rev0 | 21.09.2017



RIKA Innovative Ofentechnik GmbH
4563 Micheldorf/Austria, Müllerviertel 20
Telefon: +43 7582 686-41, Fax-DW: 43
E-Mail: verkauf@rika.at

RIKA.AT