



BRECKWELL

Exceptional Heat, Outstanding Value

2915 E. Randol Mill Road
Arlington, Texas 76011
www.breckwell.com
817.652.9602 fax 817.652.9635

INSTRUCTIONS FOR 1992 – 1998 4 RPM ANALOG TO 4 RPM DIGITAL

1. Start by unplugging the stove.
2. Empty the hopper.
3. Remove the existing wiring harness by unplugging each component from the harness and disconnecting it from the terminal strip. NOTE: Save the old harness, you may need to create a few extension wires from it later.
4. Install the new wiring harness using the new digital wiring diagram. NOTE: On the black and white wires that connect to the terminal strip, you will have to remove the terminals and strip the ends. You then can attach the black wire directly across from the power cord black wire and the white wire directly across from the power cord white wire as shown in the wiring diagram. On your stove there are two low limit thermodiscs. You now need only one of these. This is indicated as the "proof of fire" snap disk on the wiring diagram.
5. If your stove is a 1992 or 1993 model it does not have an igniter. These 2 wires will not attach to anything. Simply attach some electrical tape to these terminals to insure that they will not short out against anything.
6. If you have a P22 or P23 stove that used the 3 or 4 speed control board previously, you will need to enlarge the hole for the control panel using the attached template page.
7. Once the hole has been cut plug the wiring harness Molex connector to the back of the control board and mount it.
8. Set the switch on the top of the control board to "MANUAL" and plug in the stove.
9. The stove is now ready to operate.

On the new control system, the room air blower will not come on until the low limit thermodisc with brown wires has activated.

See the attached page for instructions on how to operate your new control panel.

PARTS NEEDED FOR UPGRADE

Control Panel – C-E-301

Wiring Harness – C-E-UH1000

**A-E-950 KIT
UPGRADE**



BRECKWELL

Exceptional Heat, Outstanding Value

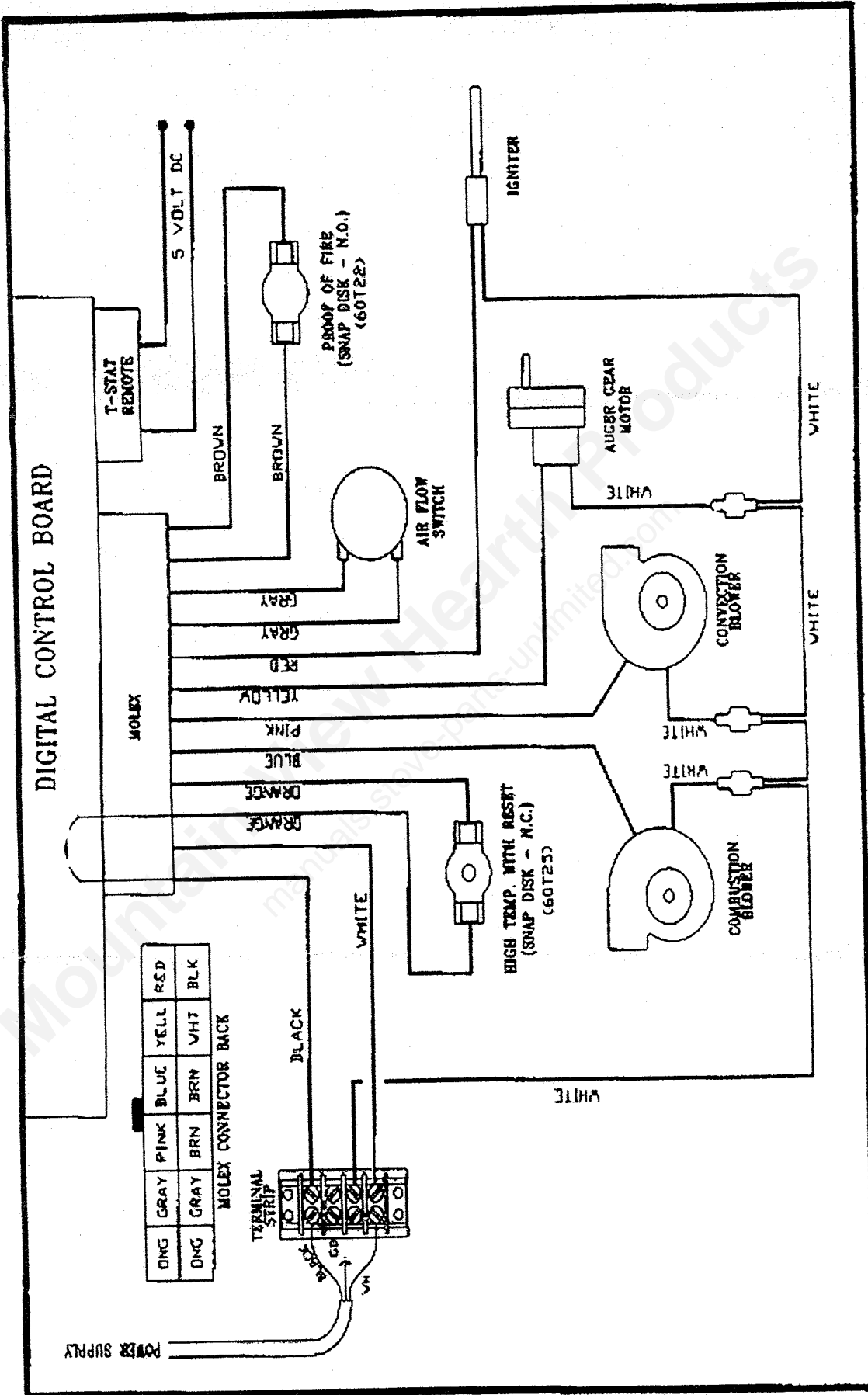

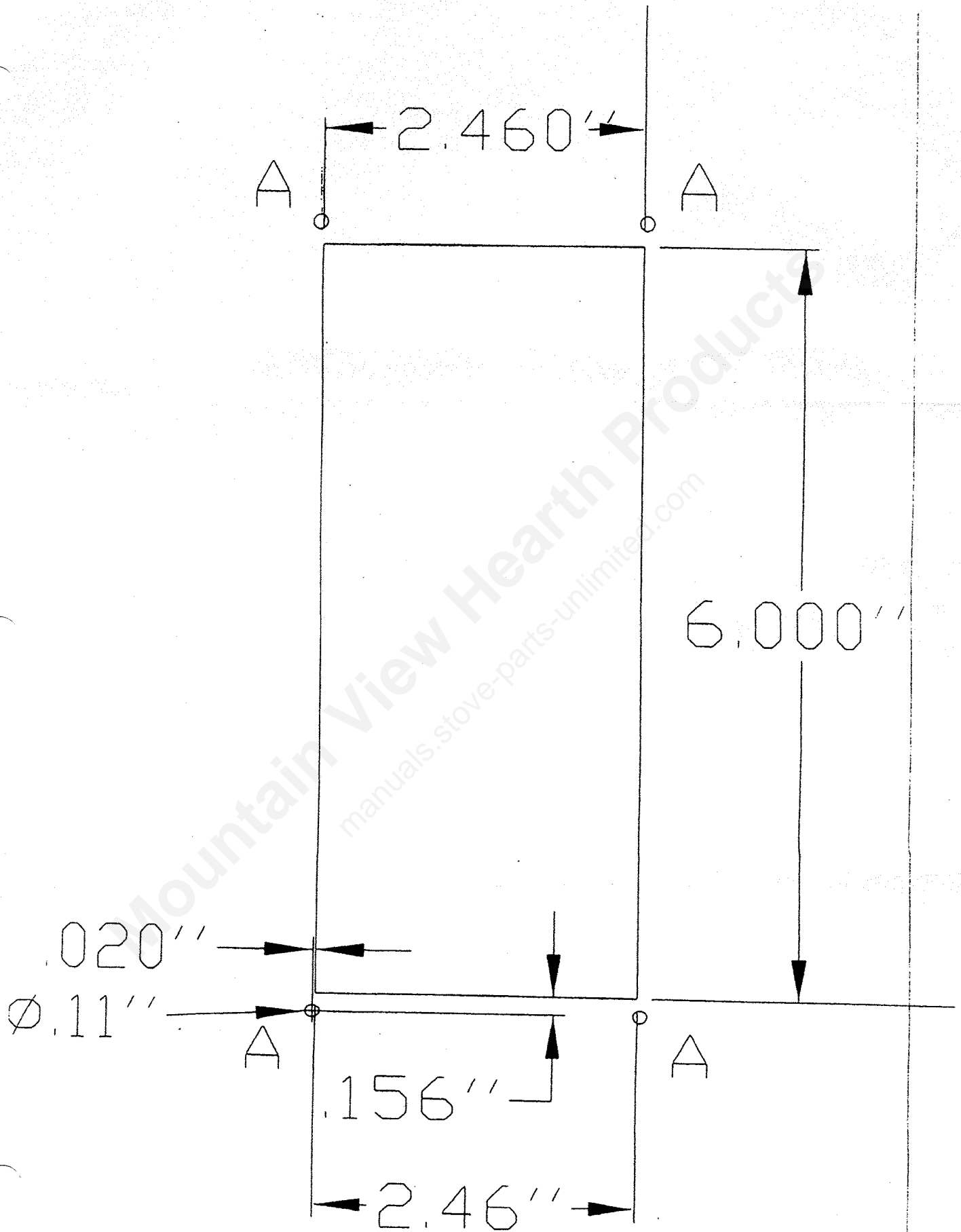

PANEL CONTROLS (See Figure 12)

The blowers and automatic fuel supply are controlled from a panel on the left-hand side of the BIG E. The control panel functions are as follows.

a. ON/OFF SWITCH

- When pushed the stove will automatically ignite. No other firestarter is necessary. The igniter will stay on for at least 10 and up to 15 minutes, depending on when Proof of Fire is reached. The fire should start in about 5 minutes.
- The green light located above the On/Off button (in the On/Off box) will flash during the ignition start-up period. (See figure 12)
- The Heat Level Advance is inoperable during the ignition start period. When the green light continuously stays on the Heat Level Advance can be adjusted to achieve the desired heat output.

NOTE: If the stove has been shut off, and you want to re-start it while it is still warm, the "on/off" button must be held down for 2 seconds.

b. FUEL FEED SWITCH

- When the "Fuel Feed" button is pushed and held down the stove will feed pellets continuously into the burnpot.
- While the stove's auger system is feeding pellets the green light (in the "Fuel Feed" box) will be on. (See figure 12)

CAUTION: DO NOT USE THIS CONTROL DURING NORMAL OPERATION BECAUSE IT COULD SMOTHER THE FIRE AND LEAD TO A DANGEROUS SITUATION.

c. HIGH FAN SWITCH

- The room air fan speed varies directly with the feed rate. The "HIGH FAN" switch overrides this variable speed function. It will set the room air blower speed to high at any feed rate setting.
- When the "HIGH FAN" button is pushed the room air fan will switch to its highest setting.
- When this button is pushed again the room air fan will return to its original setting based on the Heat Level Advance setting.

d. RESET TRIM

Different size and quality pellet fuel may require adjustment of the "1" feed setting on the Heat Level Advance bar graph. This is usually a one-time adjustment based on the fuel you are using. The "RESET TRIM" button when adjusted will allow for 3 different feed rate settings for the #1 feed setting only. To adjust simply push the "RESET TRIM" button while the stove is operating at setting "1" and watch the bar graph.

- When the "1" & "3" lights are illuminated on the bar graph the low feed rate is at its "lowest" setting. (Approx. 0.9 pounds per hour)
- When the "1" light is illuminated on the bar graph the low feed rate is at its "normal" setting.
- When the "1" & "4" lights are illuminated on the bar graph the low feed rate is at its "highest" setting.

NOTE: When the stove is set on "1" the "reset trim" values will be shown on the Heat Level Advance bar graph. For example if the Reset Trim is set to its lowest setting every time the stove is set to low the "1" and "3" lights will be illuminated on the bar graph.

e. HEAT LEVEL ADVANCE

- This button when pushed will set the pellet feed rate, hence the heat output of your stove. The levels of heat output will incrementally change on the bar graph starting from level "1" to "5".

NOTE: When dropping 3 or more heat level settings (4 to 1, or 5 to 2 or 1) push the 'High Fan' button and allow the room air fan to run at that setting for at least 5 minutes to prevent the stove from tripping the high temp thermodisk. If the high temp thermodisk does trip see "SAFETY FEATURES".

CAUTION: THE "5" SETTING IS DESIGNED FOR TEMPORARY USE ONLY. IF USED FOR EXTENDED PERIODS, IT CAN SHORTEN THE LIFE EXPECTANCY OF THE UNITS COMPONENTS. AVOID USE AT THIS SETTING FOR MORE THAN ONE OR TWO HOURS AT A TIME.

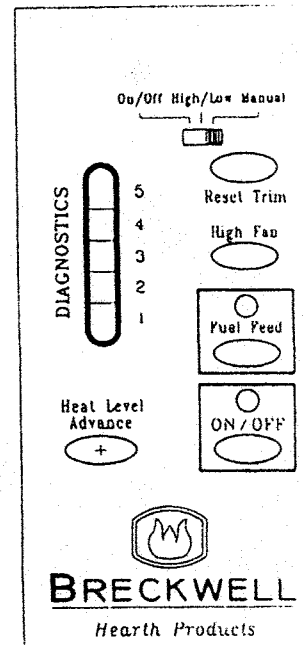

FIGURE 12

OPERATION THERMOSTAT

A thermostat may help you maintain a constant house temperature automatically. A millivolt thermostat is required. A fixed wall mount or Breckwell's hand held model can be used. The control panel can be set up two ways to operate your stove in thermostat mode.

REQUIREMENTS FOR THERMOSTAT

- A MILLIVOLT THERMOSTAT IS REQUIRED.
- Unplug stove from power outlet.
- Remove control board from stove.
- The two thermostat wires connect to the terminal block on the lower left side of the back of the control board. (See figure 21)
- Insert the wires in the terminal side and tighten the two screws.

MODES

TO SWITCH BETWEEN ANY OF THE THREE MODES THE STOVE MUST BE SHUT OFF, THE NEW MODE SELECTED, AND THE STOVE RESTARTED.

MANUAL MODE

- In this mode the stove will operate only from the control panel as detailed in the **OPERATION** section of this owner's manual.

HIGH/LOW THERMOSTAT MODE

- When engaged in this mode the stove will automatically switch between two settings. When warm enough, it will switch to the #1 or low setting. The room air blower will also slow to its lowest speed.
- The Heat Level Advance setting on the bar graph will stay where it was initially set. When the house cools below the thermostat setting, the stove will switch to the feed rate of the heat level advance setting.

ON/OFF THERMOSTAT MODE

- In this mode when the home is warm enough the stove will shut off. The fans will continue to run until the stove cools.
- When the home cools below the thermostat setting, the stove will automatically restart and run at the last feed rate setting.

NOTE: When in "high/low" or "on/off" thermostat mode -

- Do not operate the stove higher than the #3 setting. Set damper control rod approximately $\frac{1}{2}$ " to $\frac{3}{4}$ " out. This will vary depending on elevation and weather conditions. Observe stoves operation and adjust damper as necessary.

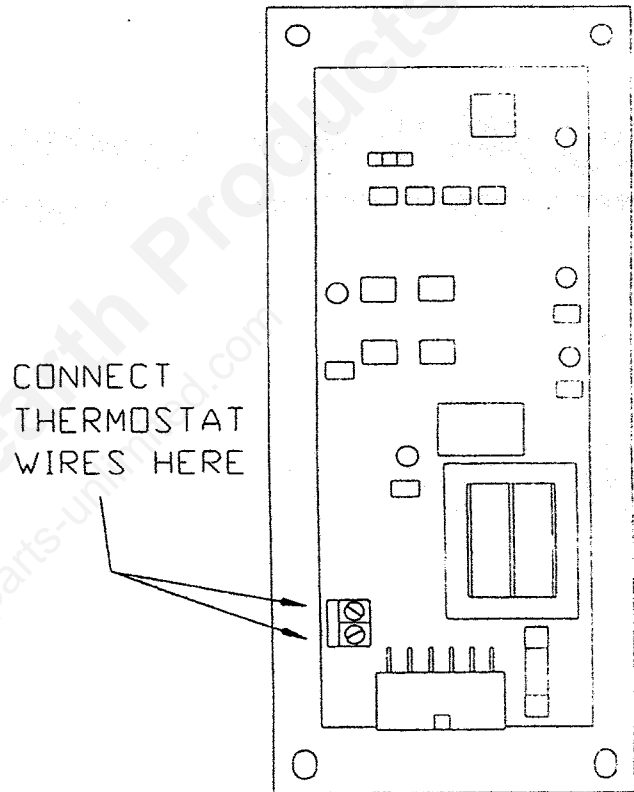
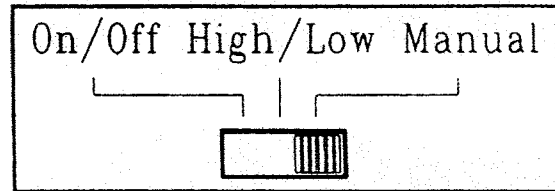
**FIGURE 14**

When your stove acts out of the ordinary, the first reaction is to call for help. This guide may save time and money by enabling you to solve simple problems yourself. Problems can be caused by to only five factors: 1) poor fuel; 2) poor operation or maintenance; 3) poor installation; 4) component failure; 5) factory defect. You can usually solve those problems related to 1 and 2. Your dealer can solve problems relating to 3, 4 and 5. Refer to figures 19, 20 and 21 to help locate indicated parts.

STOVE SHUTS OFF AND THE # 2 LIGHT FLASHES	
Possible Causes:	Possible Remedies: (Unplug stove first when possible)
1 Airflow switch hose or stove attachment pipes for hose are blocked.	Unhook air hose from the air switch and blow through it. If air flows freely, the hose and tube are fine. If air will not flow throw the hose, use a wire coat hanger to clear the blockage.
2 The air inlet, burnpot, interior combustion air chambers, combustion blower, or exhaust pipe are blocked with ash or foreign material.	Follow all cleaning procedures in the maintenance section of the owner's manual.
3 The firebox is not properly sealed.	Make sure the door is closed and that the gasket is in good shape. If the ash door has a latch, make sure the ash door is properly latched and the gasket is sealing good. If the stove has just a small hole for the ashes to fall through under the burnpot, make sure the slider plate is in place to seal off the firebox floor.
4 Vent pipe is incorrectly installed.	Check to make sure vent pipe installation meets criteria in owner's manual.
5 The airflow switch wire connections are bad.	Check the connectors that attach the gray wires to the air switch.
6 The gray wires are pulled loose at the Molex connector on the wiring harness.	Check to see if the gray wires are loose at the Molex connector.
7 Combustion blower failure.	With the stove on, check to see if the combustion blower is running. If it is not, you will need to check for power going to the combustion blower. It should be a full current. If there is power, the blower is bad. If there is not, see #8.
8 Control board not sending power to combustion blower.	If there is no current going to the combustion blower, check all wire connections. If all wires are properly connected, you have a bad control board.
9 Control board not sending power to air switch.	There should be a 5-volt current (approximately) going to the air switch after the stove has been on for 30 seconds.
10 Air switch has failed (very rare).	To test the air switch, you will need to disconnect the air hose from the body of the stove. With the other end still attached to the air switch, very gently suck on the loose end of the hose (you may want to remove the hose entirely off the stove and the air switch first and make sure it is clear). If you hear a click, the air switch is working. BE CAREFUL TOO MUCH VACUUM CAN DAMAGE THE AIR SWITCH.

STOVE SHUTS OFF AND THE # 3 LIGHT FLASHES	
Possible Causes:	Possible Remedies: (Unplug stove first when possible)
1. The hopper is out of pellets.	Refill the hopper.
2. The air damper is too far open for a low feed setting.	If burning on the low setting, you may need to close the damper all the way (push the knob in so it touches the side of the stove)
3. The burnpot is not pushed completely to the rear of the firebox.	Make sure that the air intake collar on the burnpot is touching the rear wall of the firebox.
4. The burnpot holes are blocked.	Remove the burnpot and thoroughly clean it.
5. The air inlet, the interior chambers, or exhaust system has a partial blockage.	Follow all cleaning procedures in the maintenance section of the owner's manual.
6. The auger shaft is jammed.	Start by emptying the hopper. Then remove the auger motor by removing the auger pin. Remove the auger shaft inspection plate in the hopper so that you can see the auger shaft. Gently lift the auger shaft straight up so that the end of the auger shaft comes up out of the bottom auger bushing. Next, remove the two nuts that hold the top auger biscuit in. Then rotate the bottom end of the auger shaft up towards you until you can lift the shaft out of the stove. After you have removed the shaft, inspect it for bent flights, burrs, or broken welds. Remove any foreign material that might have caused the jam. Also, check the auger tube for signs of damage such as burrs, rough spots, or grooves cut into the metal that could have caused a jam.
7. The auger motor has failed.	Remove the auger motor from the auger shaft and try to run the unit. If the motor will turn the shaft is jammed on something. If the motor will not turn, the motor is bad.
8. The Proof of Fire (POF) thermodisk has malfunctioned.	Temporarily bypass the POF thermodisk by disconnecting the two brown wires and connecting them with a short piece of wire. Then plug the stove back in. If the stove comes on and works, you need to replace the POF thermodisk. This is for testing only. DO NOT LEAVE THE THERMODISC BYPASSED. Your blowers will never shut off and if the fire went out the auger will continue to feed pellets until the hopper is empty if you leave the POF thermodisk bypassed
9. The high limit thermodisk has tripped or is defective.	Wait for the stove to cool for about 30 - 45 minutes. It should now function normally. If not use the owner's manual to locate the high limit thermodisk. To test if the thermodisk is bad, you can bypass it as described previously for the POF thermodisk.
10. The fuse on the control board has blown.	Remove the control board. On the back there is one fuse. If it appears to be bad, replace it with a 5 Amp 250 Volt fuse. Plug the stove back in and try to run the unit.
11. The control board is not sending power to the POF thermodisk or other auger system components.	There should be a 5-volt (approximately) current going to the POF thermodisk after the stove has been on for 10 minutes.

STOVE FEEDS PELLETS, BUT WILL NOT IGNITE	
<u>Possible Causes:</u>	<u>Possible Remedies:</u>
1. Air damper open too far for ignition.	Push the air damper in closer to the side of the stove for startup. In some situations it may be necessary to have the damper completely closed for ignition to take place. After there is a flame, the damper can then be adjusted for the desired feed setting.
2. Blockage in igniter tube or inlet for igniter tube.	Find the igniter housing on the backside of the firewall. The air intake hole is a small hole located on bottom side of the housing. Make sure it is clear. Also, look from the front of the stove to make sure there is not any debris around the igniter element inside of the igniter housing.
3. The burnpot is not pushed completely to the rear of the firebox.	Make sure that the air intake collar on the burnpot is touching the rear wall of the firebox.
4. Bad igniter element.	Put power directly to the igniter element. Watch the tip of the igniter from the front of the stove. After about 2 minutes the tip should glow. If it does not, the element is bad.
5. The control board is not sending power to the igniter.	Check the voltage going to the igniter during startup. It should be a full current. If the voltage is lower than full current, check the wiring. If the wiring checks out good, the board is bad.

SMOKE SMELL COMING BACK INTO THE HOME	
<u>Possible Causes:</u>	<u>Possible Remedies:</u>
1. There is a leak in the vent pipe system.	Inspect all vent pipe connections. Make sure they are sealed with RTV silicone that has a temperature rating on 500 degree F or higher. Also, seal joints with UL-181-AP foil tape. Also, make sure the square to round adapter piece on the combustion blower has been properly sealed with the same RTV.
2. The gasket on the combustion blower has gone bad.	Inspect both gaskets on the combustion blower to make sure they are in good shape.

CONVECTION BLOWER SHUTS OFF AND COMES BACK ON	
<u>Possible Causes:</u>	<u>Possible Remedies:</u>
1. The convection blower is overheating and tripping the internal temperature shutoff.	Clean any dust off of the windings and fan blades. If cleaning the blower does not help, the blower may be bad.
2. Circuit board malfunction.	Test the current going to the convection blower. If there is power being sent to the blower when it is shut off, then the control board is fine. If there is NOT power being sent to the blower when it shuts off during operation, then you have a bad control board.

STOVE WILL NOT FEED PELLETS, BUT FUEL FEED LIGHT COMES ON AS DESIGNED	
Possible Causes:	Possible Remedies:
1. Fuse on control board blew	Remove the control board. On the back there is one fuse. If it appears to be bad, replace it with a 5 Amp 250 Volt fuse. Plug the stove back in and try to run the unit.
2. High limit switch has tripped or is defective	Wait for the stove to cool for about 30 - 45 minutes. It should now function normally. If not use the owner's manual to locate the high limit thermodisk. To test if the thermodisk is bad, you can bypass it as described previously for the POF thermodisk.
3. Bad auger motor	Remove the auger motor from the auger shaft and try to run the unit. If the motor will turn, the shaft is jammed on something. If the motor will not turn, the motor is bad.
4. Auger jam	Start by emptying the hopper. Then remove the auger motor by removing the auger pin. Remove the auger shaft inspection plate in the hopper so that you can see the auger shaft. Gently lift the auger shaft straight up so that the end of the auger shaft comes up out of the bottom auger bushing. Next, remove the two nuts that hold the top auger biscuit in. Then rotate the bottom end of the auger shaft up towards you until you can lift the shaft out of the stove. After you have removed the shaft, inspect it for bent flights, burrs, or broken welds. Remove any foreign material that might have caused the jam. Also, check the auger tube for signs of damage such as burrs, rough spots, or grooves cut into the metal that could have caused a jam.
5. Loose wire or connector	Check all wires and connectors that connect to the auger motor, high limit switch, and the Molex connector.
6. Bad control board	If the F2 fuse is good, the wires and connectors check out good, and the high limit switch did not trip, test for power going to the auger motor. If there is not a full current going to the auger motor when the fuel feed light is on, you have a bad control board.

- GLASS "SOOT'S" UP AT A VERY FAST RATE
- FLAME IS LAZY, DARK, AND HAS BLACK TIPS
- AFTER STOVE HAS BEEN ON FOR A WHILE, THE BURNPOT OVERFILLS

<u>Possible Causes:</u>	<u>Possible Remedies:</u>
1 Stove or vent pipe is dirty, which restricts airflow through the burnpot.	Follow all cleaning procedure in the maintenance section of the owner's manual.
2 Vent pipe installed improperly.	Check to make sure the vent pipe has been installed according to the criteria in the owner's manual.
3 Air damper is set too far in (closed) for a higher setting.	Pull the damper knob farther out away from the side of the stove and try to burn the unit again.
4 Burnpot holes are blocked.	Remove the burnpot and thoroughly clean it.
5 Air damper is broken.	Visually inspect the damper assembly. Make sure the damper plate is attached to the damper rod. When the damper rod is moved the plate should move with it.
6 Blockage in air intake pipe.	Visually inspect the air intake pipe that leads into the burnpot for foreign material.
7 Circuit board malfunction.	Time the fuel feed light at each setting (after the stove has completed the startup cycle). Make sure the times match the auger timing chart. If the auger motor runs constantly, the board is bad
8 Combustion blower is not spinning fast enough.	Test the RPM on the blower after the blades have been cleaned. The RPM should be approximately 3000 RPM.
9 Bad Pellets (Applies to GLASS "SOOT'S" UP AT A VERY FAST RATE Only)	The brand of pellets or the batch of pellets that are being used may be of poor quality. If possible, try a different brand of pellets. You might also want to try a brand that is made from a different type of wood (softwood vs. hardwood). Different woods have different characteristics when being burned.
10. The trim setting on the low feed rate is too low (Applies to GLASS "SOOT'S" UP AT A VERY FAST RATE Only)	Use the "Reset Trim" button to increase the low feed rate setting. If the 1 & 3 lights are on, the stove is currently on the lowest setting. If only the 1 light is on, the stove is in the default (medium) setting. If the 1 & 4 lights are on, the stove is in the high trim setting for the low feed rate. If the stove is being burned on one of the two lower settings, advance to the next trim setting and try burning the stove.

HIGH LIMIT SWITCH KEEPS TRIPPING	
Possible Causes:	Possible Remedies:
1. The convection blower is overheating and tripping the internal temperature shutoff.	Clean any dust off of the windings and fan blades. If oiling the blower does not help, the blower may be bad.
2. The stove is being left on the highest setting for extended periods of time.	The highest heat level setting is designed for use over short periods of time. Burning the stove on the highest setting for longer than 1 – 2 hours could lead to potential overheating situations.
3. Fuel other than wood pellets is being burned in the stove.	Breckwell pellet stoves are designed and tested to use wood pellets. While it is possible to burn a corn mixture (corn mixed in with wood pellets) in the stove, it is not recommended to burn above the number 3 heat level. Check for signs of fuel other than wood pellets. If there are signs of corn being used, find out what mixed was being used and what setting. No other types of fuel have been approved for Breckwell pellet stoves. If there are signs of other types of fuel being used, advise the consumer to stop using them immediately.
4. Power surge or brown out situation.	A power surge, spike, or voltage drop could cause the high limit switch to trip. Check to see if a surge protector is being used on the stove. If not, recommend one to the consumer.
5. High limit switch is malfunctioning.	If the other items check out ok, replace the high limit switch.

DIGITAL CIRCUIT BOARD TIMING RATES	
Heat Level Setting	ON Time
1 & 3	0.8 seconds
1	0.9 seconds
1 & 4	1.2 seconds
2	1.9 seconds
3	2.4 seconds
4	3.6 seconds
5	4.5 seconds
Total Cycle Time	14.5 seconds

SMOKE SMELL OR SOOT BUILD-UP

Because it is a wood-burning device, your Breckwell may emit a faint wood-burning odor. If this increases beyond normal, or if you notice an unusual soot build-up on walls or furniture, check your exhaust system carefully for leaks. All joints should be properly sealed. Also clean your stove, following instructions in **"MAINTENANCE"**. If problem persists, contact your dealer.