

Wood

Pellet

Stoves

"1989"



B R E C K W E L L

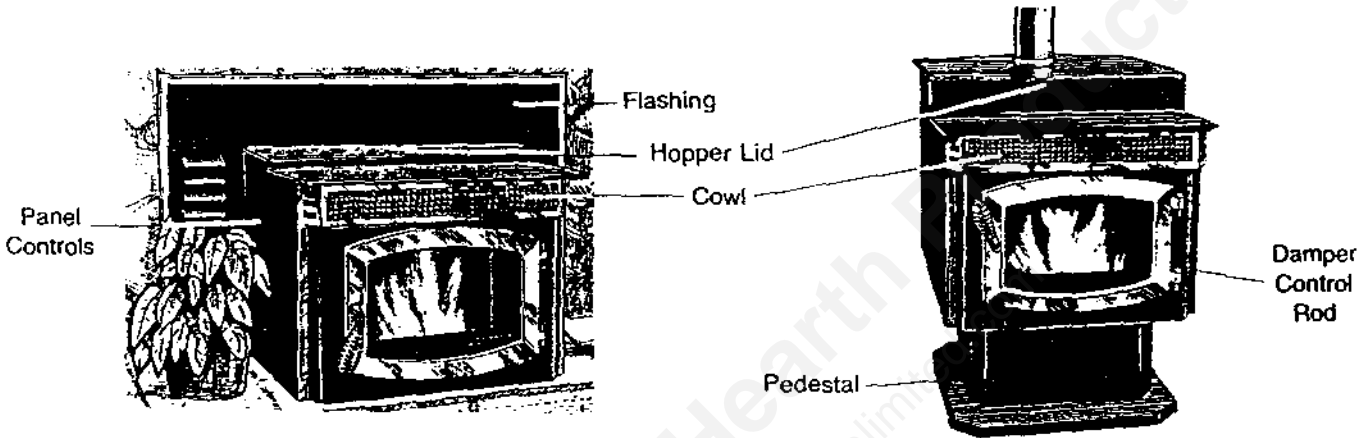

# OWNERS MANUAL

Manufactured by  
National Steelcrafters of Oregon, Inc.  
P.O. Box 2501  
Eugene, Oregon 97402  
503-683-3210

MODEL P24I     Fireplace Insert  
MODEL P24FS    Freestanding Stove

**SAFETY NOTICE:** If your appliance is not properly installed a house fire may result. For your safety, follow the installation directions. Contact local building or fire officials about restrictions and installation inspection requirements in your area.

ALL UNITS TESTED AND LISTED BY



Thank you for purchasing the Breckwell Pellet Burning Stove. You are now prepared to burn wood in the most efficient, convenient way possible. To achieve the safest, most efficient and most enjoyable performance from your stove, you must do three things; 1) Install it properly 2) Operate it cor-

rectly and 3) Maintain it regularly. The purpose of this manual is to help you do all three. PLEASE read this manual thoroughly before beginning your installation and KEEP IT in a handy place for future reference and owners.

## CONTENTS:

- 1.0 Introduction
- 2.0 Installation
  - 2.1 Clearances
  - 2.2 Combustion Air Supply
  - 2.3 Venting
  - 2.4 Electrical Installation
  - 2.5 Special Mobile Home Requirements
- 3.0 Operation
  - 3.1 Proper Fuel
  - 3.2 Pre-Startup Check
  - 3.3 Building A Fire
  - 3.4 Panel Controls
  - 3.5 Damper Control
  - 3.6 Breckwell Tools
  - 3.7 Shut Down Procedure
  - 3.8 Safety Features
- 3.9 Operating Safety Precautions
- 4.0 Maintenance
  - 4.1 Ash Disposal
  - 4.2 Firebox Cleaning
  - 4.3 Blowers
  - 4.4 Chimney Cleaning
- 5.0 Trouble Shooting Guide
  - 5.1 Fuel Will Not Feed
  - 5.2 Fire Goes Out
  - 5.3 Smokey Fire
  - 5.4 No Air Flow From Heat Exchanger
  - 5.5 No Power
  - 5.6 Blowers Will Not Operate
  - 5.7 Noisy Operation
- 6.0 Replacement Parts List

## 1.0 INTRODUCTION

This stove has been independently tested and approved in accordance with the specifications and procedures outlined in Underwriters' Laboratories, Inc., standards for safety UL 1482, UL 907 solid fuel type room heaters, April 1987, and HUD requirements for installation as a stove heater and insert for masonry or metal fireplaces, plus Oregon new rules for mobile homes (814-23-900 through 814-23-909).

This appliance is designed specifically for use only with pelletized wood. It is approved for residential installation according to current national and local building codes as a free standing room heater, as an insert, and as a zero clearance (with heater in place), when installed on the hearth of a masonry or metal fireplace. It is also approved as a mobile home heater

which is designed for connection with an outside air source.

The stove will not operate using natural draft, or without a power source for the blower systems and fuel feeding systems and must not be burned with any coal type of artificial fuels.

This stove is designed to provide the optimum proportions of fuel to air to the fire and will burn free of smoke and soot. Any blockage of the air supply to or from the stove will seriously degrade the performance and will be evidenced by a smoking exhaust and a sooting window. For the best operation the ash content of the pellet fuel should be less than 1% and the calorific value approximately 8200 BTU/LB. Avoid high ash content fuels as this will rapidly fill up the burn pot and eventually cut off the combustion air supply.

## 2.0 INSTALLATION

The Breckwell P24I has been tested and listed for installation into masonry fireplaces and factory-built "zero-clearance" fireplaces of the following description: all brands at least 30" wide and 20" high.

Also into mobile home factory built fireplaces of the following description: all brands at least 30" wide and 20" high.

The Breckwell P24FS has been tested and listed for installation in residential, mobile home, and alcove applications.

### 2.1 Clearances (figure 1)

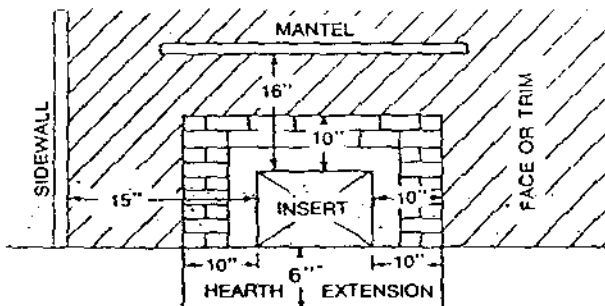

\*6" may be reduced 1" for each 2" of rise of hearth. We recommend fire rated hearth carpet

### P24FS CLEARANCE TO COMBUSTIBLES

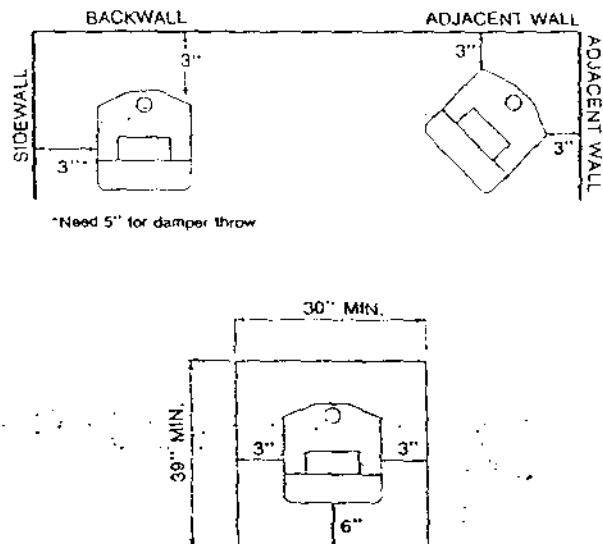

\*Need 5" for damper throw

FIGURE 1

## 2.2 Combustion Air Supply

For mobile home installation the stove must be connected to an outside source of combustion air. For residential installations this is also recommended as it will improve efficiency. A 1 3/4" inside diameter metallic pipe, either flexible or rigid

should be used when outside air is to be connected. It attaches to an outlet on the stoves' rear (see figure 2) and its terminus should be installed with a rodent guard.

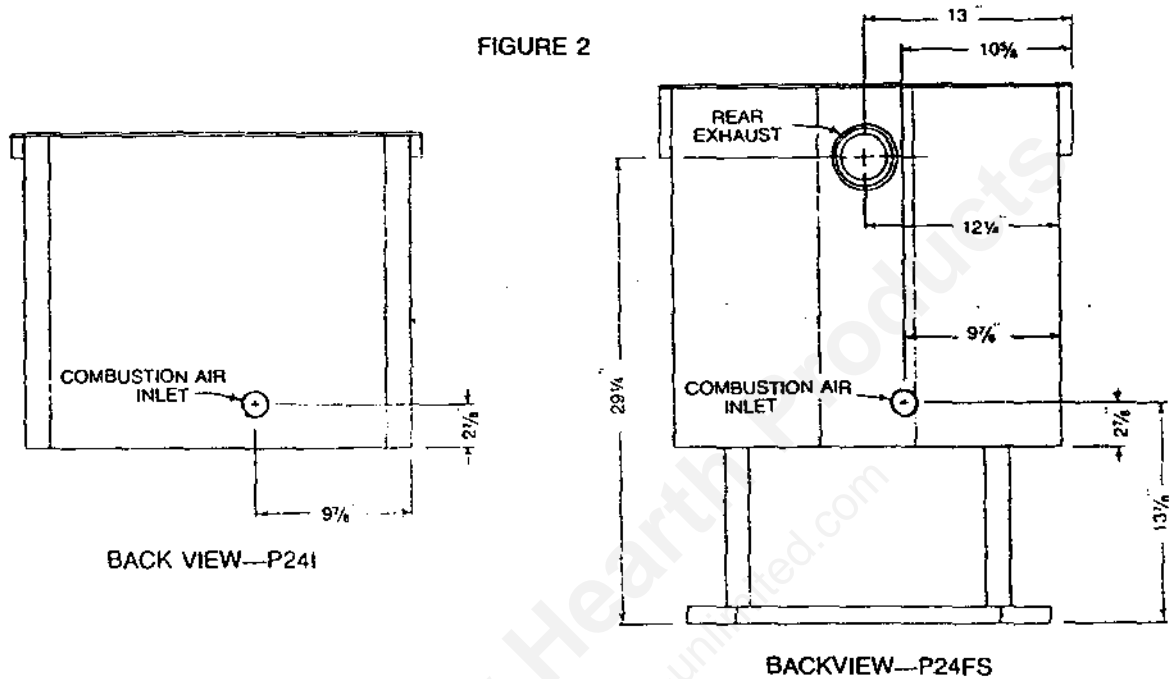

### Sources of Outside Combustion Air

#### A. Fireplaces

1. Ash cleanout door on exterior wall.
2. Hole drilled in rear wall of firebox when fireplace is on an exterior wall (masonry fireplace only).
3. Top of chimney (see figure 7). There should be a 180 degree bend at top in this type of installation. All factory built fireplaces requiring outside air must use this method.

#### B. Freestanding Stoves

1. Hole in floor to accommodate outside air pipe.
2. Hole in rear wall to accommodate outside air pipe.

## 2.3 Venting

Both Breckwell models are equipped with an exhaust connector for 3" diameter vent. 4" diameter may be used as well. Class "A" chimney is not required.

#### A. P24FS INSTALLATIONS

Venting should be with 3" or 4" diameter pellet vent (L-Vent) chimney. Stove was tested with Simpson Dura-vent Brand. Refer to the instructions provided by the chimney manufacturer, especially when passing through a wall, ceiling, or roof. Model P24FS can be vented out the top or rear. To change from top to rear exhaust, refer to figure 3.

#### CHANGING FROM TOP EXHAUST TO REAR EXHAUST

Remove screws A-(4) and screws B-(4). Exchange pipe adapter C with cover plate D. Replace screws A and B. Remove cover plate on back of stove and mount on top of stove. **NOTE:** Inspect gaskets and replace if necessary. **SEAL MUST BE AIR TIGHT.**

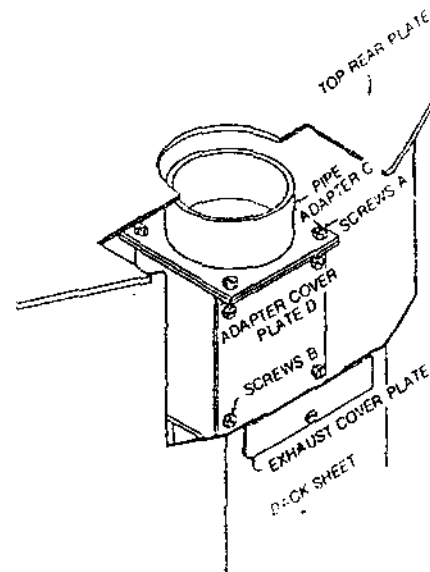

FIGURE 3

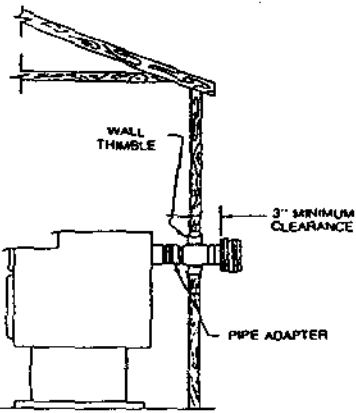

FIGURE 4

### P24FS REAR EXHAUST INSTALLATION Horizontally Through Wall

1. Position stove, adhering to clearances shown in section 2.1.
2. Locate position of hole in wall, directly behind stove's exhaust vent (see figure 2).
3. Cut opening in wall,  $9\frac{5}{8}$ " round for 3" L-Vent,  $10\frac{5}{8}$ " round for 4" L-Vent. This provides space for thimble which fits between wall studs. Attach thimble.
4. Attach pipe adapter to stove. (Dura-Vent part #3079/3").
5. Attach enough pipe to penetrate and extend at least 3" beyond exterior walls.
6. Attach cap and seal outside wall thimbles with non-hardening waterproof mastic.

### P24FS VERTICAL INSTALLATION New Chimney System

1. Locate stove, Drop plumb bob to center of appliance flue outlet, mark center point on ceiling. Cut square hole in ceiling, for firestop support assembly (for 3", cut  $9\frac{5}{8}$ " square; 4", cut  $10\frac{5}{8}$ " square).
2. Connect pipe adapter to stove. Then connect chimney sections.
3. When pipe passes through firestop at ceiling, tighten bolt and clamp around pipe.
4. Always maintain 3" clearance from combustible materials. When passing through additional floors or ceilings always install firestop spacer.
5. After lining up for hole in roof, cut either round or square hole in roof, always 3" larger all the way around pipe. Install upper edge and sides of flashing under roofing materials, nail to the roof along upper edge. Do not nail lower edge. Seal nail heads with non-hardening water proof mastic.
6. Apply non-hardening, waterproof mastic where the storm collar will meet the vent and flashing, slide storm collar down until it sets on the flashing and put cap on, twist to lock.

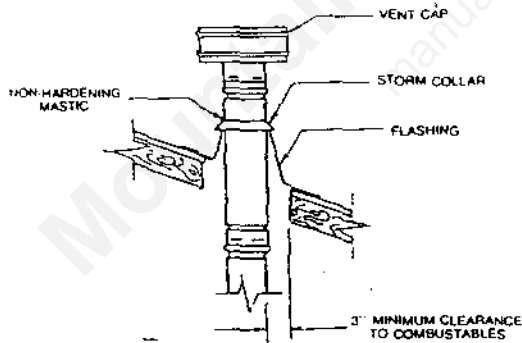

FIGURE 6

### P24FS VERTICAL INSTALLATION Existing Chimney System

Adapters are available to adjust from 3" to 6" or 8". As an alternative, 3" or 4" pipe can be run inside existing chimney.

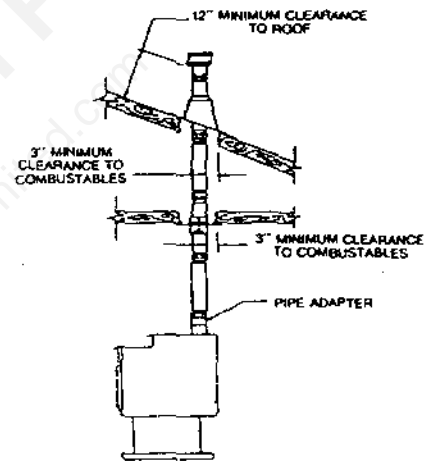

FIGURE 5

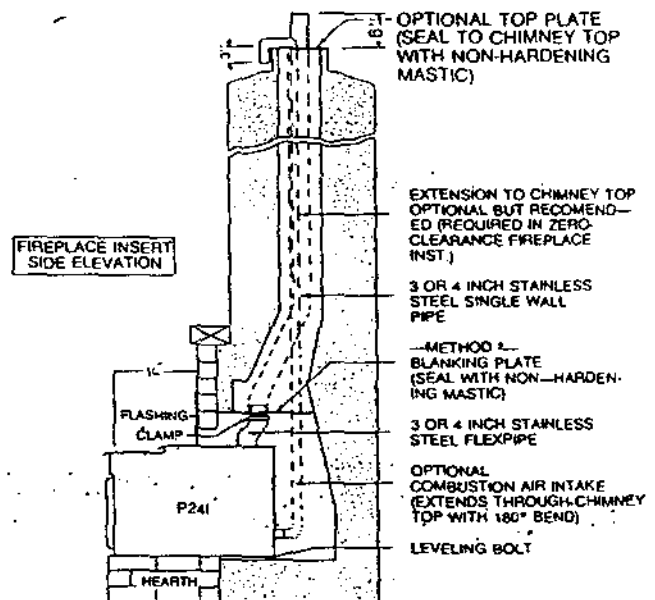

FIGURE 7

### B. P24I INSTALLATIONS

Insert installations must be vented with 3" or 4" pipe (see figure 7). Pipe may be single wall stainless steel flexible pipe. In zero-clearance fireplace installations, vent must extend to chimney top. In masonry fireplaces, vent may extend to just past blanking plate. See section 2.2 for outside air access information.

## PROCEDURE (P241 installations, continued)

### METHOD 1.

#### VENT PIPE AND COMBUSTION AIR PIPE TO OUTSIDE

1. Measure chimney height from bottom to top tile, subtract one foot. This should be the approximate length of combustion air supply pipe. Vent pipe should terminate at least 6" above chimney. Combustion air pipe should extend out of chimney and bend 180 degrees to eliminate water from running down the Pipe. SEE FIGURE 7.

2. Set insert on hearth, adjust leveling bolt in the bottom center of the stove. Slide stove in far enough to attach vent pipe and combustion air pipe. NOTE: two wing nuts allow vent collar to slide vertically to clear especially low fireplace lintels. Sealer should be used to assure air tight connection. Also, at least 1 self tapping screw should be used to connect vent pipe.

3. Attach flashing, route power supply cord out the side nearest a 110V receptacle. Slide in insert until flashing touches face of fireplace. Seal is not necessary.

4. Cut hole in blanking plate for vent pipe and combustion air pipe. Install blanking plate on top of chimney and seal with non-hardening mastic. Install vent cap.

### METHOD 2.

#### VENT PIPE AND COMBUSTION AIR PIPE THROUGH BLANKING PLATE (masonry fireplaces only)

1. Measure size of flue opening in fireplace. Build blanking plate to fit. Cut out holes for flue pipe and combustion air pipe (if used). Install and seal blanking plate with non-hardening mastic

(it must be sealed air tight or smoke spillage could occur).

2. Measure from floor of fireplace to blanking plate. This is approximate length of vent pipe. Combustion air supply pipe (if used) should be 4 feet longer to eliminate pulling ash back into combustion chamber.

3. Slide vent pipe up through hole in blanking plate, leaving enough underneath to grab and pull down. Slide combustion air supply pipe up through blanking plate leaving about one foot underneath.

4. Set insert on hearth, adjust leveling bolt. Slide in far enough to attach vent pipe and combustion air pipe. Seal connections as in method 1. Attach flashing, route power cord, and slide in insert until flashing touches face of fireplace.

### 2.4 Electrical Installation

This stove is provided with an 8 foot grounded electrical cord extending from the rear of the stove. This should be connected to a standard 110 volt, 60 hz electrical outlet. The approximate power requirements are 250 watts.

### 2.5 Special Mobile Home Requirements

Mobile Home installations made prior to the initial sale of the mobile home are governed by US Department of Housing and Urban Development (HUD) standards. They include the following: a. Do not install in a sleeping room b. Stove should be grounded, with #8 copper wire and terminated with NED approved grounding device. c. Stove should be attached to mobile home during shipment.

## 3.0 OPERATION

### 3.1 Proper Fuel

**THIS STOVE IS APPROVED FOR BURNING PELLETIZED WOOD FUEL ONLY!** Pellets should be no larger than ¼ inch diameter and 1 inch long. Longer or thicker pellets sometimes bridge the auger flight which prevents proper pellet feed. The burning of wood in forms other than pellets is not permitted. It will violate the building codes for which the stove has been approved and will void all warranties. The design incorporates automatic and continuous feed of the pellet fuel into the fire at a carefully prescribed rate. Any additional fuel introduced by hand will not increase heat output, but may seriously impair the stove's performance by generating considerable smoke. Do not burn wet pellets. The stove's performance depends heavily on the quality of your pellet fuel. Avoid pellet brands which display these characteristics.

- Excess Fines - "fines" is a term describing crushed pellets or loose material that looks like dust or sand. Pellets can be screened before being placed in hopper to remove most fines.
- Ash content greater than 1%.
- Binders - Some pellets are produced with petroleum distillates or other materials to hold them together, or bind them. These pellets are harder and can jam auger.

Poor quality pellets will often create smoke, dirty glass, and could damage the auger. National Steelcrafters of Oregon cannot accept responsibility for damage due to poor quality pellets.

### 3.2 Pre-Startup Check

Clean firebox of all residue ash by scraping ash into ash pan (see sections 4.1 and 4.2). Remove burn pot and dump ash into ash pan. Remove ash pan and dump ash into metal container with lid. Replace ash pan and burn pot. Clean door glass

(if necessary). Check for sufficient fuel in hopper and refill if necessary. NOTE: Hopper capacity is approximately 50 lbs. in insert (P241) and 50 lbs. in freestanding stove (P24FS).

### 3.3 Building a Fire

NOTE: During the first few fires, your stove will emit an odor as the high temperature paint cures or becomes seasoned to the metal. Maintaining smaller fires will minimize this. Avoid placing items on stove top during this period as paint could be affected.

- Check to make sure power cord from stove is plugged in.
- Fill burn pot half full of pellets by hand, add fire starter, light and close door.
- Push damper control rod (located on right side of stove) all the way in.
- Push reset switch and push on-off switch to "on" position. Turn fuel control knob to "4", or desired setting.
- When fire is burning well in burn pot, pull damper rod out to proper setting. NOTE: Pellets will not start to fall into burn pot until firebox has reached a preset temperature, usually in about 5 minutes. After pellets start dropping turn fuel control knob to desired setting and set damper.

### 3.4 Panel Controls

The blowers and automatic fuel supply (auger) are controlled from a panel on the left side of the stove. The on-off switch turns the auger and blowers on. The reset switch is a safety device that in case of a power failure, shuts the auger off. When power is restored the reset switch must be pushed for the auger to work again. The "manual feed" switch should only be used to fill the auger tube, when needed, or to check if the auger is working. It should not be used under normal operating

conditions, or overfiring may occur. The fuel supply knob controls the rate and amount of fuel supplied to the fire (see figure 8).

Set on #1 approximately 1 lb. per hour  
#2 approximately 2 lbs. per hour  
#3 approximately 3 lbs. per hour  
#4 approximately 4 lbs. per hour

#1 will be low burn and #4 will be high burn. NOTE: these rates will vary with brand of pellets used.

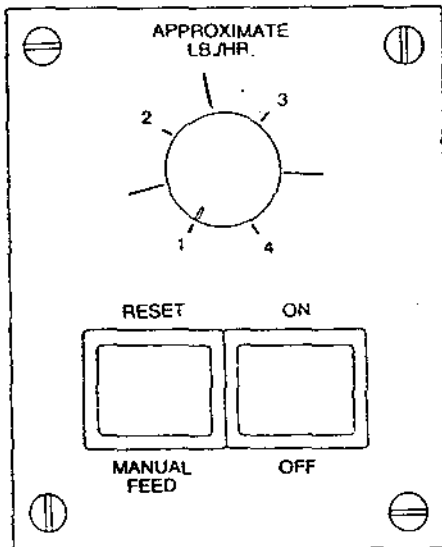

FIGURE 8

### 3.5 Damper Control

The damper control rod on the stove's right side adjusts the combustion air. This control is necessary due to the different burn characteristics of different installations and pellet brands. It allows you to improve the efficiency of your stove.

You should adjust the rod based on the fire's appearance. A low, reddish, dirty fire can be improved by pulling the damper out slightly. A "blow torch" fire can be improved by pushing the damper in a bit.

As a general rule, on a low feed rate setting, the damper will be in. On higher feed rates, the damper should be more open. Through trial and error, you will find the best settings. Consult your dealer if you need help.

### 3.6 Breckwell Maintenance Tools

Tools have been provided with your stove to help you with the following functions:

- Open Hopper Lid - When stove is set at higher burn rates, the hopper lid can become very hot. Use tool to lift lid. Do not touch hot lid or burns could occur. (Tool A)
- Stir Pellets In Hopper - Unlike liquids in a tank, pellets do not drain evenly into the auger. Bridging across the opening can occur. Pellets can become hung up on one slope of the hopper. Occasionally "stirring" the hopper can help. (Tool A)
- Ash Pan Removal - see instructions in section 4.1. (Tool A)

d. Cleaning Heat Exchanger Tubes - see instructions, section 4.2. (Tool B)

e. Scrape ashes from burn pot. (Tool A)



### 3.7 Shut Down Procedure

Turning the Breckwell off is a matter of pressing the control panel switch to off. The blowers will continue to operate until internal firebox temperatures have fallen to a preset level.

### 3.8 Safety Features

- If there is a power failure, the auger will not operate once power is restored. This prevents pellets being fed to a non-burning burn pot. Reset switch on the control panel will reactivate auger. The blowers will come on when power is restored to evacuate the combustion chamber of gases. If power failure is of short duration, and fire is not extinguished, pressing reset switch will allow Breckwell to perform normally without restarting the fire.
- In case of a malfunctioning convection air blower, a high temperature thermostat will shut down the auger, preventing the stove from overheating. After stove cools down, pressing reset switch will allow auger to start again. NOTE: If high temperature thermostat activates, there is an electrical component failure and it should be checked out immediately.

### 3.9 Operating Safety Precautions

- DO NOT STORE OR USE FLAMMABLE LIQUIDS, especially gasoline, in the vicinity of your Breckwell Pellet Burner. Never use gasoline, gasoline-type lantern fuel, kerosene, charcoal lighter fluid or similar fluids to start or "freshen up" a fire in this heater.
- WARNING: DO NOT OVERFIRE THIS STOVE. This may cause serious damage to your stove and void your warranty. It also may create a fire hazard in your home. IF ANY EXTERNAL PART OF THE UNIT BEGINS TO GLOW, YOU ARE OVERFIRING. Immediately press "off" switch on control panel.
- Keep all household combustibles, such as furniture, drapes, toys, etc. three feet, or a considerable distance from the burning stove.
- Maintain proper ventilation. It is important that adequate oxygen be supplied to the fire for the combustion process. Modern houses are often so well insulated, it may become necessary to open a window or install an outside air vent to provide sufficient combustion air.
- Since heating with a solid fuel fire is potentially hazardous, even with a well made and thoroughly tested stove, it would be wise to install strategically placed smoke detectors and have a fire extinguisher in a convenient location.
- Do not open door when stove is operating, unless necessary. This will create a dirty, inefficient burn and could allow sparks to escape.
- Do not permit operation by young children or those unfamiliar with stove's operation.
- Do not add more fuel than the automatic fuel system provides, as this could cause an overfiring condition.
- Do not open door if firebox is full of smoke. Wait until smoke clears out.
- If pellet feed mechanism fails and pellets are fed continuously, shut down stove immediately and pull plug. Call your dealer. Do not use stove until it has been repaired.

## 4.0 MAINTENANCE

### 4.1 Ash Disposal - (see figure 12)

Remove ashes periodically as they fill the pan. To remove pan:

- Make sure fire is out.
- Remove burnpot by grasping and twist pulling straight out. **NOTE:** Inspect burnpot periodically to see that holes have not become plugged.
- Empty ashes from burnpot into pan.
- Use tool provided to lift pan and pull out carefully.
- To replace, reverse procedure. Make sure burnpot is level when it is reinstalled.

Ashes should be placed in a metal container with a tight fitting lid. The closed container of ashes should be placed on a non-combustible floor on the ground, well away from all combustible materials pending final disposal. If ashes are disposed of by soil burial or otherwise locally dispersed, they should be retained in the closed container until all cinders have thoroughly cooled.

### 4.2 Firebox Cleaning

- The stove is designed with a built in heat exchange tube cleaner. This should be used every two or three days to remove accumulated ash on the tubes, which reduces heat transfer. Insert tool in cleaner key (see figure 10). Twist, move backwards and forwards several times. Leave key at front of stove.
- Three (3) cover plates in the firebox can be removed for periodic cleaning. The one on each side of the firebox allows access to vacuum ashes in the chamber surrounding firebox. The cover plate on the rear firebox wall allows access to the combustion blower.
- Gasket around door and door glass should be inspected and repaired or replaced when necessary (see section 6.0).

### 4.3 Blowers

- Cleaning** - Over a period of time, ashes may collect on the blades of both the combustion blower and convection blower. Periodically the blowers should be vacuumed clean as these ashes can impede performance. Access to the convection blower is through a cover plate on stove's left side.
- Oiling** - Blower manufacturers suggest oiling annually. This may require removal of the blower. Consult your dealer if you need assistance.

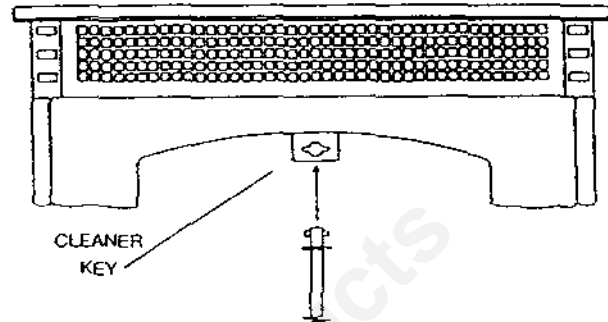

FIGURE 10

### 4.4 Chimney Cleaning

**CREOSOTE FORMATION:** When wood is burned slowly, it produces tar and other organic vapors which combine with expelled moisture to form creosote. The creosote vapors condense in the relatively cool chimney flue of a newly started fire or from a slowly burning fire.

As a result, creosote residue accumulates on the flue lining. When ignited, this creosote makes an extremely hot fire which may damage the chimney or even destroy the house.

Despite their high efficiency, pellet stoves often accumulate creosote under normal conditions.

The chimney connector and chimney should be inspected at least monthly during the heating season to determine if a creosote buildup has occurred.

If creosote has accumulated, it should be removed to reduce the risk of a chimney fire.

**INSPECTION AND REMOVAL** - Inspect the system at the stove connection and at the chimney top. Cooler surfaces tend to build creosote deposits quicker, so it is important to check the chimney from the top as well as from the bottom.

The creosote should be removed with a brush specifically designed for the type of chimney in use. A chimney sweep can perform this service. It is also recommended that before each heating season the entire system be professionally inspected, cleaned, and repaired if necessary.

## 5.0 TROUBLE-SHOOTING GUIDE

When your stove acts out of the ordinary, the first reaction is to call for help. This guide may save time and money by enabling you to solve simple problems yourself. Refer to figures 11, 12, and 13 to help locate indicated parts.

### 5.1 Fuel Will Not Feed

- Check for fuel in hopper.
- Push reset switch.
- Depress "Manual Feed" switch. If you can hear gear motor, either auger is jammed, set screw coupling is loose, or gear motor gears are stripped. To clear a jam, first insert rod up drop tube from firebox and feel for auger shaft, not pellets. If that doesn't work, empty hopper, use rod to dislodge blockage. If problem persists, contact dealer.

- Check auger fuse (located behind control panel).
- Check to see if relay is working. Listen for relay clicking on and off every 10 to 15 seconds. If it doesn't, contact dealer.
- Remove back panel from stove. If auger is not turning and relay is clicking, auger is jammed or gear motor is malfunctioning. Contact dealer if the latter.
- Check high temp and auger thermoswitches with a continuity tester.

### 5.2 Fire Goes Out

(assuming ample fuel in hopper and burnpot)

- Check for blockage in combustion air inlet and exhaust.

2. If both the combustion air blower and convection blower do not run, check thermodisc in back of stove with a continuity tester, or contact dealer.

3. Remove cover plate on back of firebox and see if combustion blower is running. Blower impeller should be clean of deposits for maximum efficiency.

### 5.3 Smokey Fire (see section 3.5 first) (reddish flame, soot deposits on door glass)

1. Check door and door glass gasket. Door should be tightly sealed. Replace gasket if necessary.

2. Check that burnpot is installed properly and holes are not plugged.

3. Check for blockage in combustion air inlet and exhaust.

4. For further checks refer to 5.2.

### 5.4 No Air From Heat Exchanger

1. Remove cover plate on side of stove and check convec-

tion air blower. Clean blower wheel if necessary. If blower is not running to full capacity, contact dealer.

2. Check for air blockage to convection blower.

### 5.5 No Power

1. Check power supply to stove.

### 5.6 Blower Will Not Operate

1. Check power supply.

2. Check blower thermodisc.

### 5.7 Noisy Operation

1. Identify source of noise (i.e. which motor).

2. Check tension of blower mounting screws.

3. Check for dirty impeller wheels on blowers.

4. Check for tight mounting bolts, if noisy auger motor.

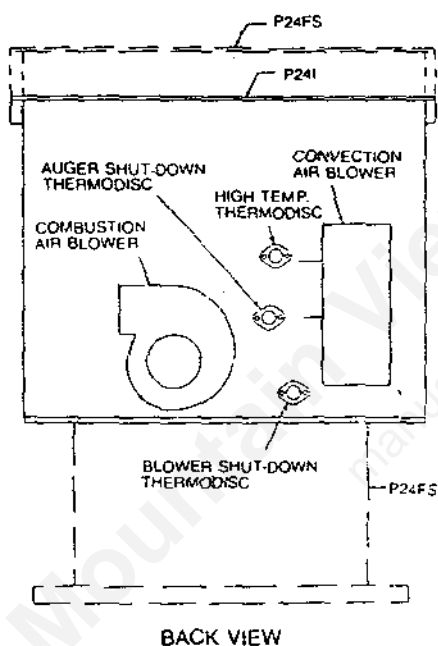

FIGURE 11

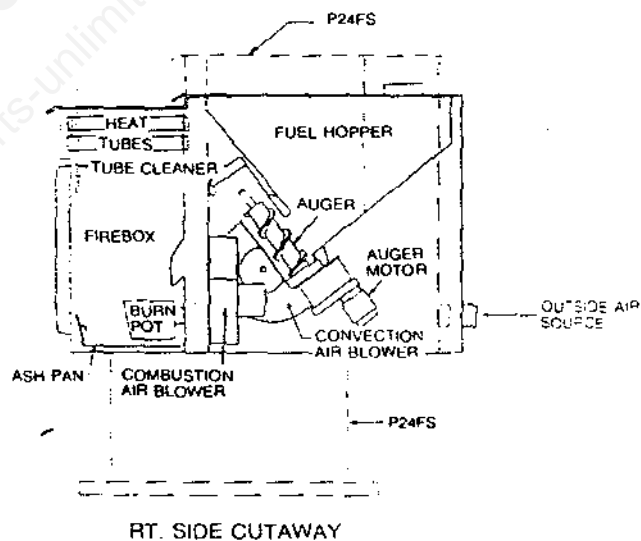

FIGURE 12

## 6.0 Replacement Parts

If Breckwell parts need replacement, we suggest you contact your dealer.

Number	Item
420	Door Gasket (five feet)
491	Window Gasket (five feet)
231	Spring Handle
300	Door Glass
5901	Furnace Cement (2 oz.)
506	Combustion Blower
501	Convection Blower
507	Auger Gear Motor
534	Gear Motor Capacitor
509	T D F Relay
513	Speed Control
527	High Temp Thermodisc (60-T21)
528	Auger Shut Down Thermodisc (60-T22)
529	Blower Shut Down Thermodisc (60-T23)
311	Window Clips
2110	Breckwell Maintenance Tools (A or B)
1466	Burn Pot

### Optional Items for Your Breckwell

1. 22-Carat Gold Plated Cowl
2. Brass Flashing Trim (P24I Only)
3. Etched Door Glass
4. Designer Colors

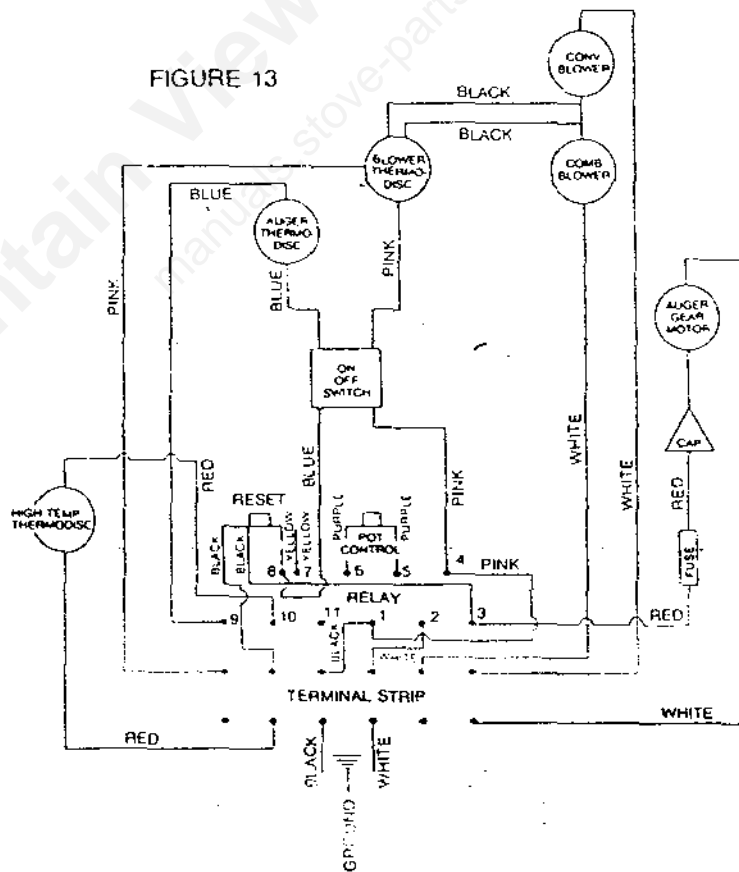

ELECTRICAL DIAGRAM