

C A D E T

B Y B R E C K W E L L

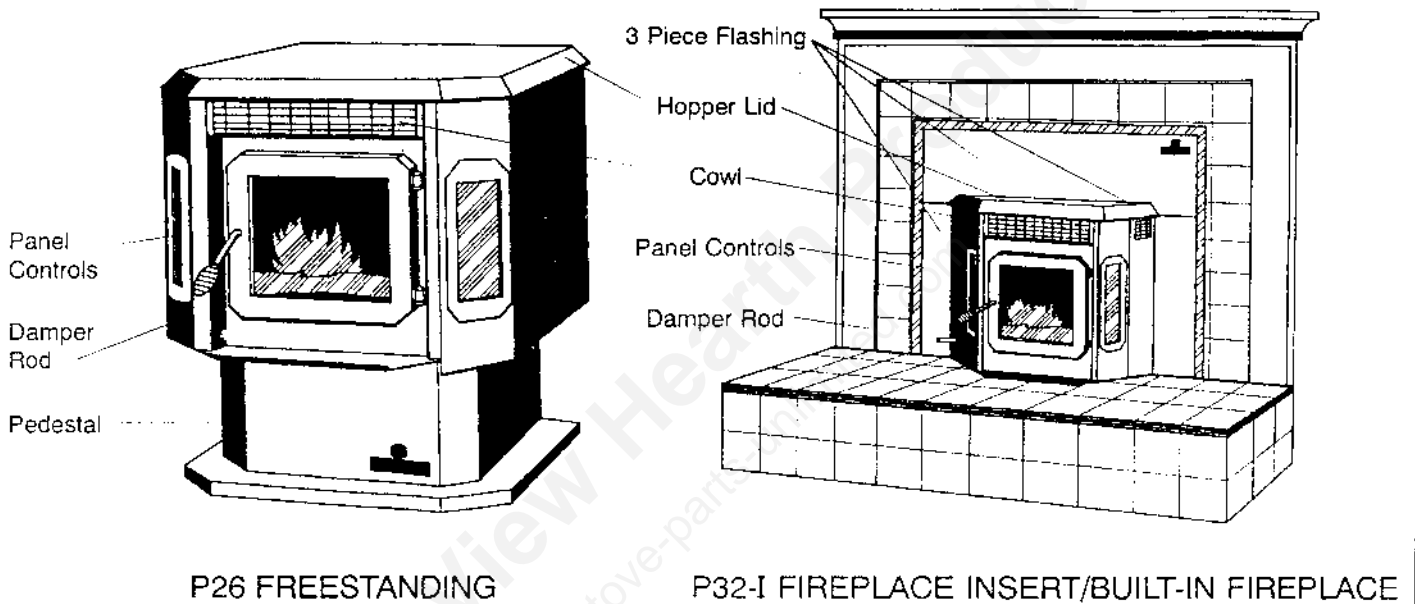

OWNERS MANUAL

SAFETY NOTICE: If your appliance is not properly installed a house fire may result. For your safety, follow the installation directions. Contact local building or fire officials about restrictions and installation inspection requirements in your area.

ALL UNITS TESTED AND LISTED BY

Warnock Hersey



ICBO TL-116 NER-QA-219

Manufactured by
National Steelcrafters of Oregon Inc.
P.O. Box 24910
Eugene, Oregon 97402

NATIONAL STEELCRAFTERS OF OREGON INC.

1194500

Thank you for purchasing a Breckwell Pellet Burning Stove. You are now prepared to burn wood in the most efficient, convenient way possible. To achieve the safest, most efficient and most enjoyable performance from your stove, you must do three things: 1) Install it properly; 2) Operate it correctly and; 3)

Maintain it regularly. The purpose of this manual is to help you do all three. **PLEASE read this manual thoroughly before beginning your installation and KEEP IT in a handy place for future reference and future owners.**

CONTENTS

1.0 Introduction	3.0 Operation	4.0 Maintenance
2.0 Installation	3.1 Proper Fuel	4.1 Ash Disposal
2.1 Preparation	3.2 Pre-Startup Check	4.2 Cleaning
2.2 Clearances	3.3 Building a Fire	4.3 Blowers
2.3 Combustion Air Supply	3.4 Panel Controls	4.4 Chimney Cleaning
2.31 When Outside Air is Not Used	3.5 Optional Thermostat	4.5 Recommended Maintenance Schedule
2.4 Venting	3.6 Damper Control	5.0 Trouble Shooting Guide
2.41 Cadet P26	3.7 Refueling	5.1 Fuel Will Not Feed
2.42 Cadet P32-I	3.8 Breckwell Tools	5.2 Fire Goes Out
2.5 Electrical Installation	3.9 Shut Down Procedure	5.3 Smoky Fire
2.6 Special Mobile Home Requirements	3.91 Safety Features	5.4 No Power
	3.92 Operating Safety Precautions	5.5 Blowers Will Not Operate Properly
		5.6 Noisy Operation
		6.0 Replacement Parts List

1.0 INTRODUCTION

Note which model you have purchased (either P26 freestanding model or P32-I built-in fireplace or fireplace insert). Some instructions herein refer to only one model or the other.

This stove has been independently tested and approved in accordance with the relevant portions of ULC S627 CSA B366.2-M1983 "Standard for Space Heaters for use with Solid Fuels", UL 1482-1988 "Standard for Room Heaters", ASTM standard E1509-93, CSA C22.2 No. 3 "Electrical Features of Solid Fuel Burning Appliances", Oregon new rules for mobile homes (814-23-900 through 814-23-909) and installation as a stove heater.

This appliance is designed specifically for use only with pelletized wood. It is designed for residential installation according to current national and local building codes as a free standing room heater, and as an insert. The P32-I is designed to be installed on the hearth of a masonry or metal fireplace and as a zero clearance fireplace, when installed in new construction.

It is also approved as a mobile home heater which is designed for connection to an outside combustion air source.

The stove will not operate using natural draft, or without a power source for the blower systems and fuel feeding systems and must not be burned with any type of coal (see section 3.1).

This stove is designed to provide the optimum proportions of fuel and air to the fire in order to burn free of smoke and soot. Any blockage of the air supply to or from the stove will degrade the performance and will be evidenced by a smoking exhaust and a sooting window. For the best operation the ash content of the pellet fuel should be less than 1% and the calorific value approximately 8200 BTU/LB. Avoid high ash content fuels as this will rapidly fill up the burn pot and eventually cut off the combustion air supply.

Commercial and industrial installations of Breckwell Pellet Stoves are strongly discouraged since operational control is often not well managed in these settings.

2.0 INSTALLATION

2.1 PREPARATION

Factory packaging must be removed and some minor assembly work is required prior to installation. Access to the rear of the stove is necessary.

Foam protective blocks must be removed from all blowers. **This is a safety precaution.** The circuit board/control panel must be unplugged and installed in the P32-I side panel. Instructions are packed with the board/panel. Free the power cord.

NOTE: Normally, your dealer will perform these functions.

2.2 CLEARANCES

The Breckwell P26 has been tested and listed for installation in residential, mobile home, and alcove applications.

The P32-I is approved for installation into masonry fireplaces, factory built, built-in zero clearance fireplaces and mobile home built-in fireplaces of the following description: all brands at least 33" wide and 20" high. The P32-I is also approved as a built-in fireplace, as long as minimum chase size and material specifications are maintained (see section 2.42D).

FLOOR PROTECTION (P26) minimum 25" wide by 29" deep. The stove must be placed on a continuous (grouted

joins) non-combustible material such as ceramic tile, cement board, brick, 3/8" asbestos millboard or equivalent, or other approved or listed material suited for floor protection. Check local codes for approved alternatives.

Clearances are measured from the sides, back and face of stove body (see figure 1A).

DO NOT USE MAKESHIFT MATERIALS OR COMPROMISES IN THE INSTALLATION OF THIS UNIT.

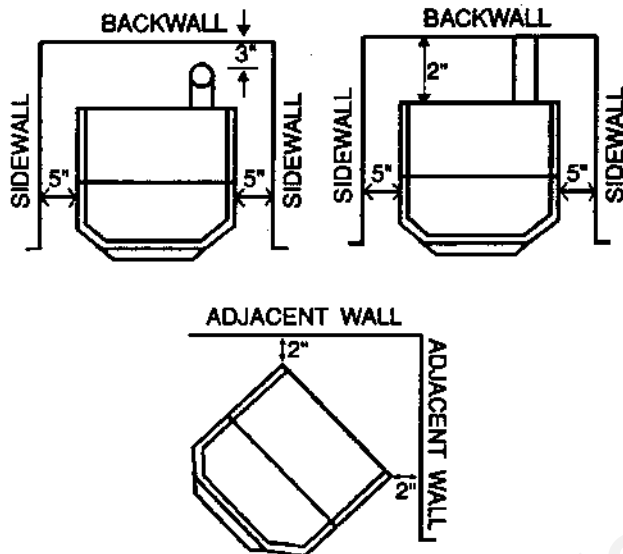

ALCOVE DIMENSIONS

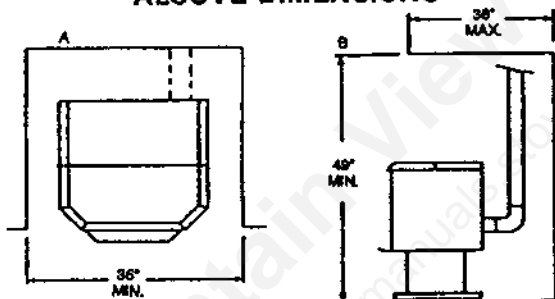

SIDEWALL CLEARANCES

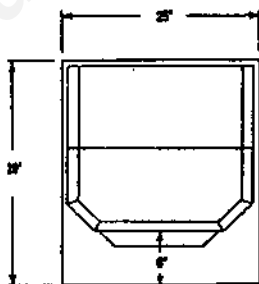

FLOOR PROTECTION
(Minimum 25" wide x 29" deep)

P26

Figure 1A

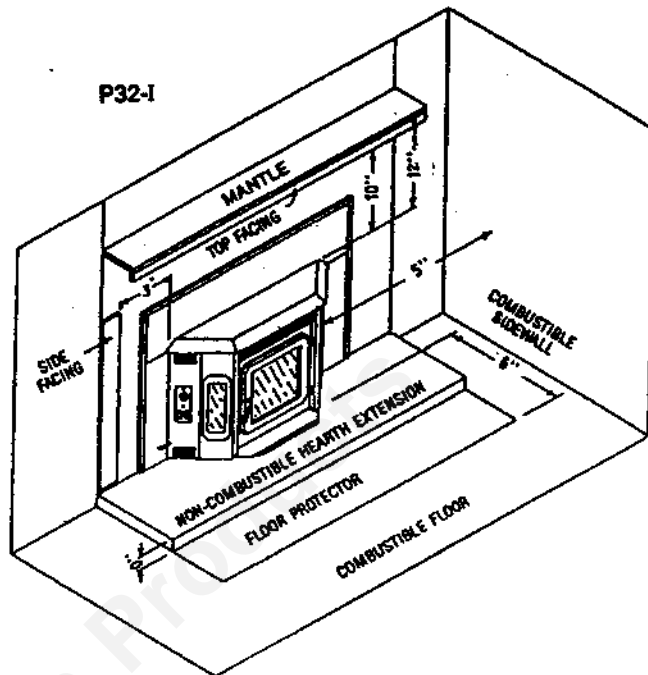
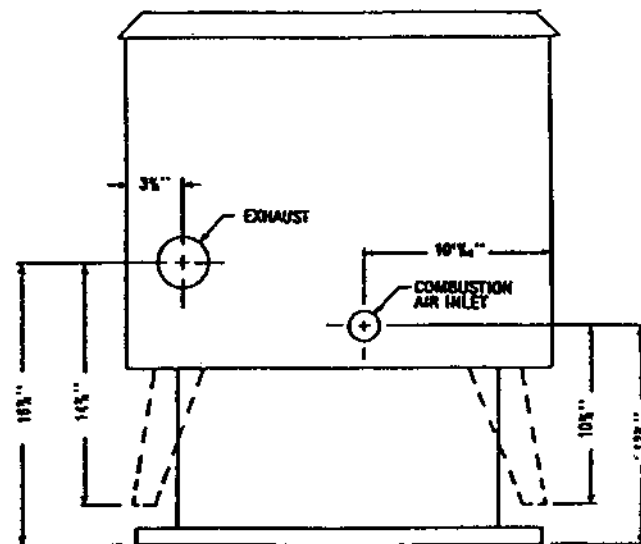

Figure 1B

2.3 COMBUSTION AIR SUPPLY

For mobile home installation the stove must be connected to an outside source of combustion air. A 1 1/4" inside diameter metallic pipe, either flexible or rigid should be used when outside air is to be connected. It attaches to an outlet at the stove's rear (see figures 2A and 2B) and its terminus should have a wind hood or be turned 45° to prevent overdraft when located on the windy side of home. In some cases rodent guards are suggested.



P26 REAR VIEW

Figure 2A

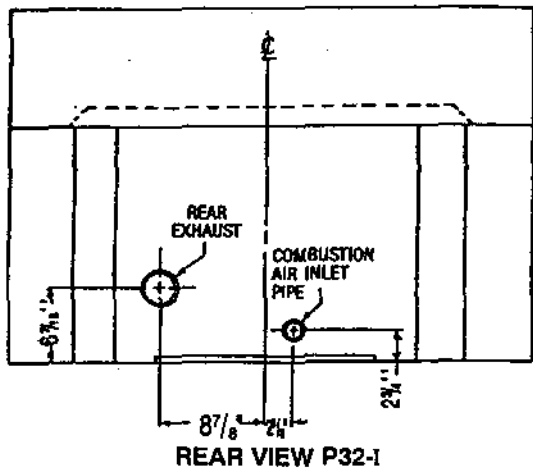

Figure 2B

Sources of Outside Combustion Air

- A. In fireplaces
 1. Ash cleanout door
 2. Masonry fireplaces only — hole drilled in rear of firebox (when fireplace is on an outside wall)
 3. Top of chimney (see figure 9). All factory built fireplaces requiring outside air must use this method unless outside air is already provided.
- B. For freestanding installations
 1. Hole in floor near stove rear
 2. Hole in wall behind stove

2.31 WHEN OUTSIDE AIR IS NOT USED

When outside air is not used, the P26 stove must be fitted with a Check Valve (part #A-CV). It is not required on the P32-I. This prevents smoke spillage in the event of combustion blower failure and competing negative pressure in the house, such as bathroom or kitchen exhaust fans. This part must be attached to the end of the combustion air inlet tube at the rear of the stove (see figure 3).

If outside air is not used, it is important that combustion air is easily available to the inlet. Hence, in P32-I installations, flashing vents should not be restricted. The flashing should not necessarily seal the fireplace face.

NOTE: DO NOT OPERATE P26 UNLESS EITHER CHECK VALVE OR OUTSIDE AIR IS CONNECTED.

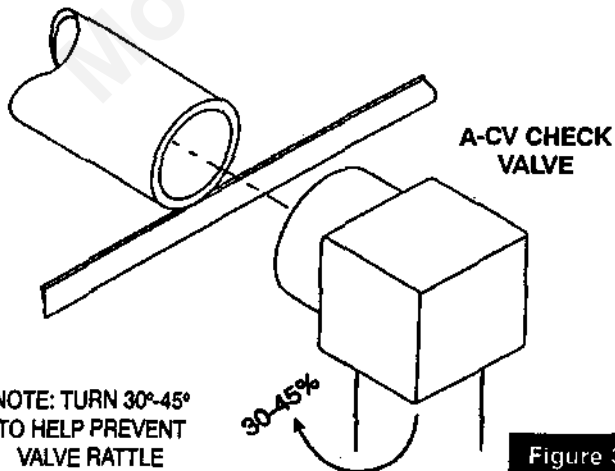

Figure 3

2.4 VENTING

The Breckwell Cadet models are certified for use with listed TYPE L vent, 3" or 4" diameter in size. The stove was tested with Simpson Duravent brand. Class "A" chimney is not required. Refer to the instructions provided by the vent manufacturer, especially when passing through a wall, ceiling or roof.

- Do not connect this unit to a chimney flue serving another appliance
- Do not install a flue damper in the exhaust vent of this unit. This is a pressurized exhaust system. The pipe joints should be sealed to insure consistent performance and avoid smoke spillage.

Equivalent Vent Length (EVL)

The longer the run of pipe in your installation (both with inserts and freestandings), the more restriction there is in the system. Therefore, larger diameter pipe should be used. Here is how you determine whether 3" or 4" should be used in your installation:

If you have over 15 feet of equivalent vent length, we recommend the use of 4" pipe.

To calculate EVL, use the following conversions:

- 90° elbow or "T" = 5 equivalent feet
- 45° elbow = 3 equivalent feet
- Horizontal Pipe Run = 1 equivalent foot per actual foot
- Vertical Pipe Run = 0.5 equivalent feet per actual foot

NOTE: At altitudes above 3,000 feet, we suggest the use of 4" diameter vent at an EVL of 7 feet.

2.41 P25 INSTALLATIONS

A. HORIZONTALLY THROUGH WALL (see figure 4)

NOTE: Follow L-Vent Chimney manufacturer's instructions.

1. Position stove, adhering to clearances shown in section 2.2.
2. Locate position of hole in wall, directly behind stove's exhaust vent (see figure 2A).
3. Install L-Vent wall thimble per L-Vent manufacturer's instructions.
4. Attach enough pipe to penetrate and extend at least 6" beyond exterior walls. An eight foot vertical pipe run is suggested where possible to reduce the possibility of smoke leakage in the event of a power failure.
5. Attach cap and seal outside wall thimbles with non-hardening waterproof mastic.

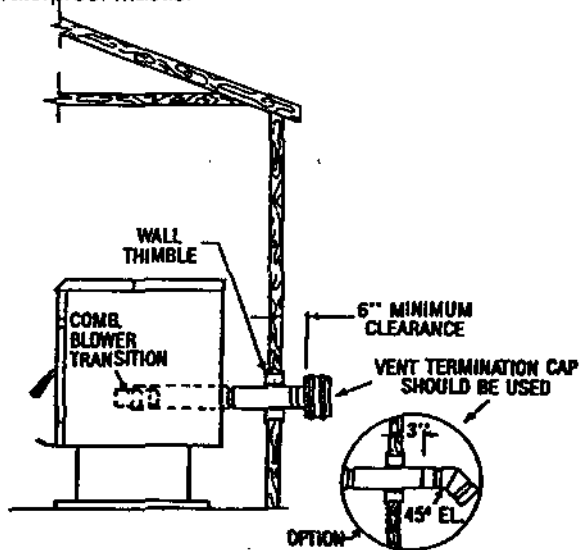

Figure 4

- Termination should not be located such that hot exhaust gases can ignite trees, shrubs, grasses, or be a hazard to children. Exhaust gases can reach temperatures of 500°F and cause serious burns if touched. Locate termination: a) not less than 3 feet above any forced air inlet located within 10 feet; b) not less than 4 feet below or horizontally from, or one foot above any door, window or gravity air inlet into any building; c) not less than two feet from an adjacent building and not less than 7 feet above grade when located adjacent to a public walkway.

B. VERTICALLY WITH NEW CHIMNEY SYSTEM (see figure 5)

NOTE: Follow L-Vent Chimney manufacturer's instructions

- Install 90° L-vent tee to stove exhaust.
- Locate stove, drop plumb bob to center of flue outlet, mark point on ceiling. Install ceiling support and L-Vent pipe per L-Vent manufacturer's instructions.
- Connect chimney sections from stove upwards.
- When pipe passes through firestop at ceiling, tighten bolt and clamp around pipe.
- Always maintain 3" clearance from combustible materials. When passing through additional floors or ceilings always install firestop spacer.
- After lining up for hole in roof, cut either a round or a square hole in the roof, always 3" larger all the way around pipe. Install upper edge and sides of flashing under roofing materials and nail to the roof along upper edge. Do not nail lower edge. Seal nail heads with non-hardening waterproof mastic.
- Apply non-hardening, waterproof mastic where the storm collar will meet the vent and flashing, slide storm collar down until it sets on the flashing, seal and install cap.

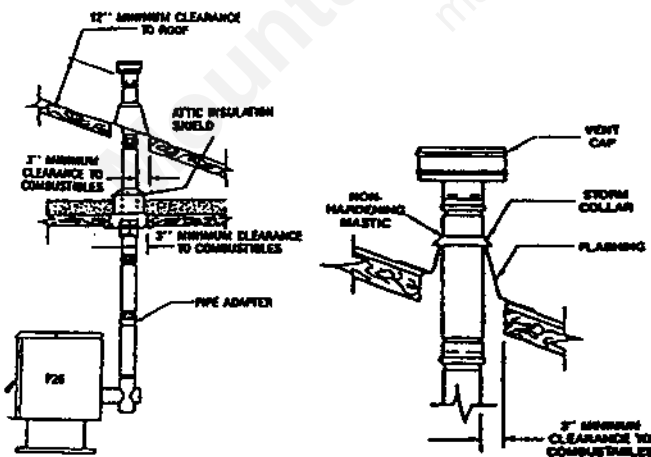

VERTICALLY WITH NEW CHIMNEY

Figure 5

C. VERTICALLY INTO EXISTING CHIMNEY SYSTEM (see figure 6)

Install 90° L-Vent tee to stove exhaust. Adapters are available to adapt from 3" L Vent to 6" or 8" Class A chimney. As an alternative, 3" or 4" L Vent can be run inside existing chimney to termination. This is the preferred method. Follow guidelines for equivalent vent length.

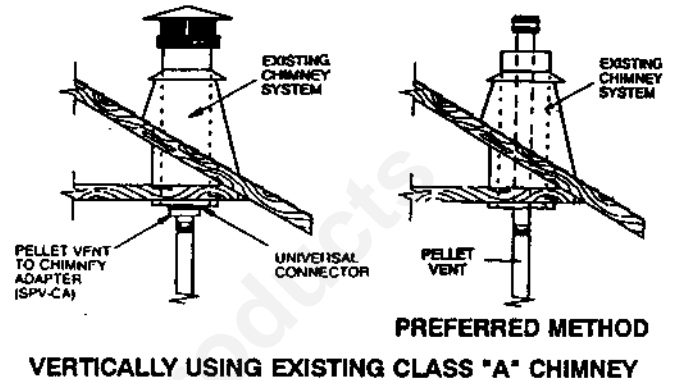

Figure 6

2.42 P32-J INSTALLATIONS

Insert installations must be vented with 3" or 4" pipe. Pipe may be single wall stainless steel flexible pipe. Vent may terminate within chimney beyond a blanking plate or extend to the chimney top. See section 2.3 for outside air access information.

The fireplace and chimney should be cleaned thoroughly before starting installation. We suggest painting the interior of particularly old and dirty fireplaces to seal any odors. In zero-clearance installations, when the fireplace opening is above the floor or raised hearth, the adjustable "Breckwell zero-clearance skirt" can be used to bridge the gap between hearth and stove bottom (see figure 7)

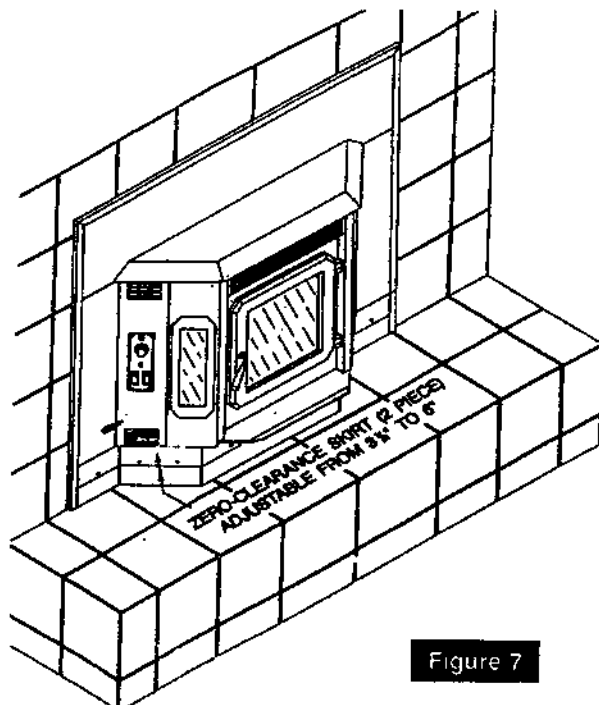

Figure 7

A. WHEN VENT PIPE EXTENDS TO CHIMNEY TOP

1. You will need a pipe length equal to the chimney height (from hearth) plus one foot. If outside combustion air is to be used, you will need a pipe length (see section 2.3) equal to the chimney height plus 12 inches.
2. Attach cerablanket wrap, which comes with your stove, to that end of vent pipe that will connect to stove. Use 12" lengths of tight gauge metal wire (not included) or metallic tape. This is to protect interior components from excess heat.
3. Set insert on hearth, adjust leveling bolts on rear sides, and slide in far enough to attach vent pipe (and combustion air pipe if used). Use RTV, metallic tape, and/or self-tapping screws to assure tight connection.
4. Attach flashing (see figure 8), route power cord out the side nearest a 120V receptacle. Slide in insert. Seal is not necessary. Do not restrict air to or from vents in flashing.
5. Measure and build chimney top. Cut out holes for vent pipe (and combustion air pipe if used). Install and seal with non-hardening mastic to prevent water leakage. Install vent cap.

B. WHEN VENT PIPE EXTENDS THROUGH CHIMNEY BLANKING PLATE

1. You will need a pipe length equal to the hearth to blanking plate height plus six inches. **NOTE:** outside combustion air cannot be drawn from chimney cavity in this installation.
2. Attach cerablanket as in section A.
3. Measure and build blanking plate. Cut out hole for vent pipe (and combustion air intake pipe, if used). Install and carefully seal blanking plate as in previous step 5. Failure to properly seal may result in smoke spillage.
4. Slide vent pipe (and intake pipe if used) up through blanking plate hole, leaving enough to grab and pull down.

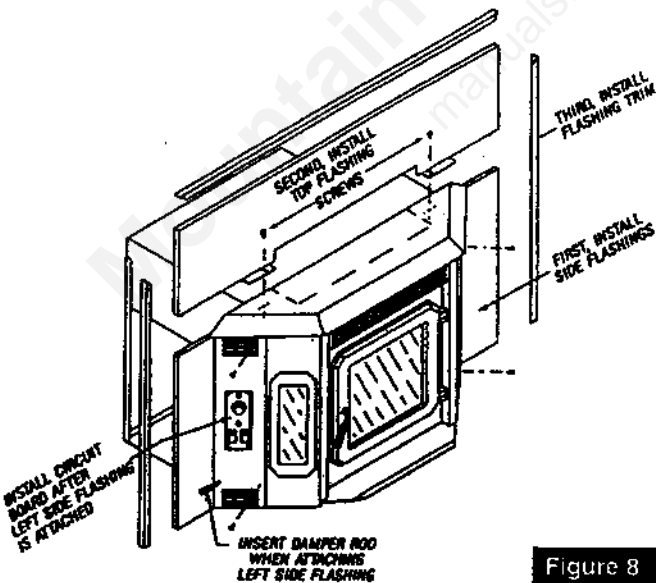

Figure 8

5. Set insert on hearth, complete steps 4, 5 and 6 in 2.42A. Be sure to seal where pipe passes through blanking plate.

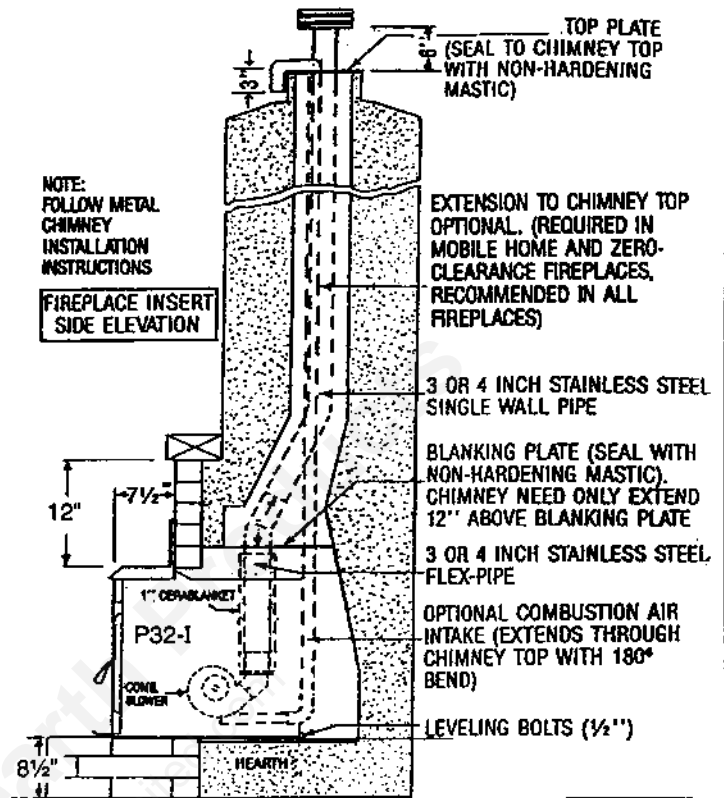

Figure 9

D. AS A BUILT-IN FIREPLACE

Figures 10A & 10B describe a Cadet P32-I installation vented into either a special chase built outside an outer wall or a false inside wall. This is especially suited for new construction or remodeling. The chase dimensions shown are minimums and must be maintained.

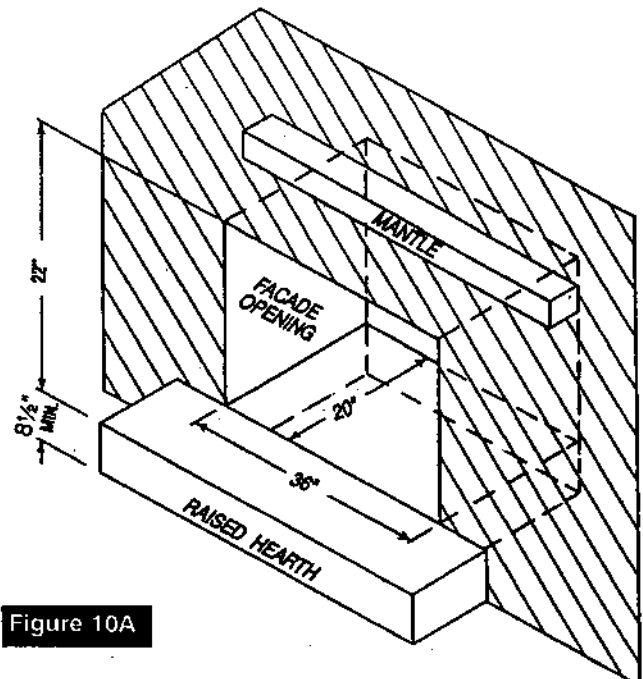

Figure 10A

3.0 OPERATION

3.1 PROPER FUEL

THIS STOVE IS APPROVED FOR BURNING PELLETIZED WOOD FUEL ONLY! Factory-approved pellets are those 1/4" or 5/16" in diameter and not over 1" long. Longer or thicker pellets sometimes bridge the auger flights which prevents proper pellet feed. Burning wood in forms other than pellets is not permitted. It will violate the building codes for which the stove has been approved and will void all warranties. The design incorporates automatic feed of the pellet fuel into the fire at a carefully prescribed rate. Any additional fuel introduced by hand will not increase heat output, but may seriously impair the stove's performance by generating considerable smoke. Do not burn wet pellets. The stove's performance depends heavily on the quality of your pellet fuel. Avoid pellet brands which display these characteristics:

- Excess Fines — "fines" is a term describing crushed pellets or loose material that looks like sawdust or sand. Pellets can be screened before being placed in hopper to remove most fines.
- Binders — Some pellets are produced with materials to hold them together, or bind them.
- High ash content — Poor quality pellets will often create smoke and dirty glass. They will create a need for more frequent maintenance. You will have to empty the burn pot and ash pan plus vacuum the entire system more often. Poor quality pellets could damage the auger. National Steelcrafters of Oregon, Inc. cannot accept responsibility for damage due to poor quality pellets. Your dealer can recommend a good quality pellet in your area.

3.2 PRE-START-UP CHECK

Clean firebox of all residue ash by scraping it into ash pan (see sections 4.1 and 4.2) Remove imitation log set, if in use. Then remove burn pot and dump ash into ash pan making sure no air holes are blocked. Remove ash pan and dump ash into metal container with lid. Replace ash pan and burn pot. Clean door glass if necessary (a dry cloth is usually sufficient). Check fuel in hopper and refill if necessary.

NOTE: Hopper capacity is approximately 50-60 lbs. in both the P26 and P32-I

3.3 BUILDING A FIRE

NOTE: During the first few fires, your stove will emit an odor as the high temperature paint cures or becomes seasoned to the metal. Maintaining smaller fires will minimize this. Avoid placing items on stove top during this period as paint could be affected.

- Check to make sure power cord from stove is plugged in.

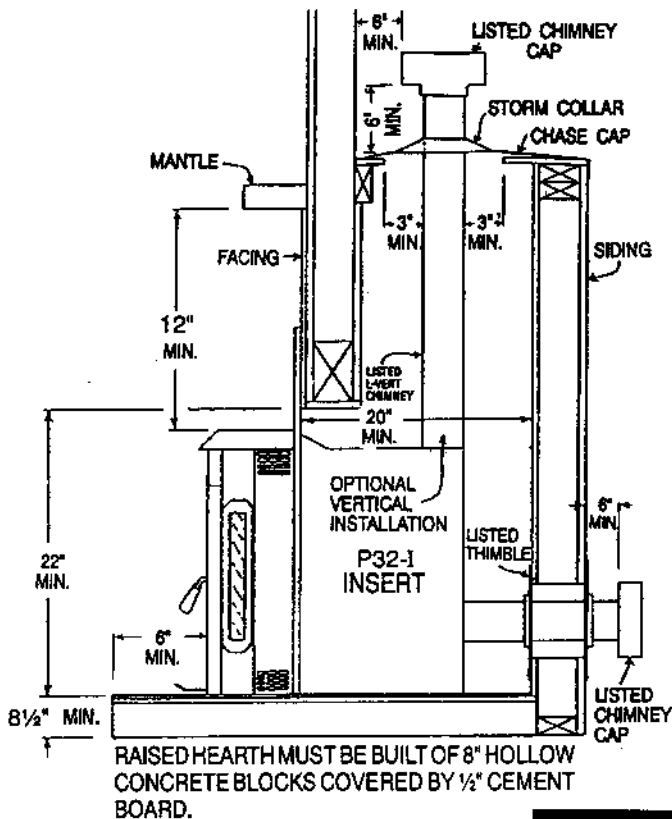

Figure 10B

2.5 ELECTRICAL INSTALLATION

This stove is provided with an 8-foot grounded electrical cord extending from the rear of the stove. This should be connected to a standard 3 prong 120 volt, 60 hz electrical outlet. Voltage variations can lead to serious performance problems. The Breckwell electrical system is designed for 120 volts AC with no more than 5% variation. National Steelcrafters of Oregon, Inc. cannot accept responsibility for poor performance or damage due to inadequate voltage. If connected to an older two-prong outlet, a separate ground wire should be run to a proper ground (refer this to a qualified electrician).

2.6 SPECIAL MOBILE HOME REQUIREMENTS

Mobile Home installations made prior to the initial sale of the mobile home are governed by US Department of Housing and Urban Development (HUD) standards. These standards include the following: a. Stove should be grounded, with #8 copper wire and terminated with NED approved grounding device; b. Stove should be attached to mobile home during shipment.

WARNING: Do not install in a sleeping room.

CAUTION: The structural integrity of the mobile home floor, wall and ceiling/roof must be maintained.

- b. Push damper control rod (located on left side of stove) all the way in.
- c. Fill burn pot by hand or by pressing "MANUAL FEED" switch on control panel (see figure 11) fill to about half full. Add approved fire starter (see section 3.92), light and close door. Keep door tightly closed during operation.
- d. Push on/off switch to "on" position. Blowers will come on. Set fuel control knob to desired setting. Push "Auger" button.
- e. After waiting 10-15 minutes, readjust damper (see section 3.6)

NOTE: Auger will not begin feeding pellets until the firebox reaches a preset temperature level (about 10-15 minutes).

3.4 PANEL CONTROLS

(see figure 11)

The blowers and automatic fuel supply (auger) are controlled from a panel on the left side of the stove. A hinged door on most models covers the panel during normal operation. The on-off switch turns the blowers on. The "auger" button activates the automatic feed system. When the green light is on, there is power to the auger circuit. The auger will not begin feeding pellets until the firebox has warmed up to a preset temperature. In case of a power outage lasting more than three to six seconds, this button must be pushed to re-engage the auger. There are six fuel feed settings. On "LOW", the feed rate is approximately 0.75 to 1.5 lb. per hour. On "MAX" the feed rate is approximately 4.25 to 4.75 lbs. per hour.

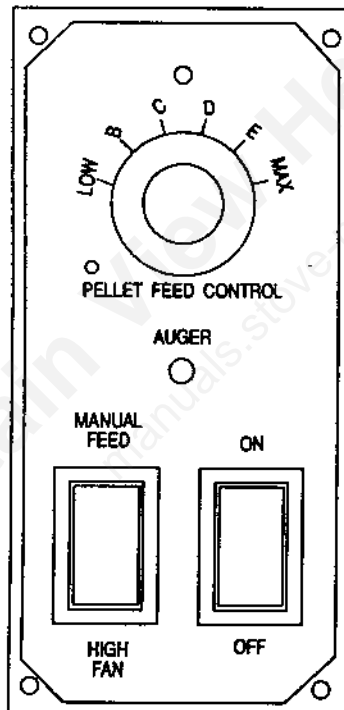

Figure 11

CAUTION: The "MAX" setting is designed for temporary use only. If used for extended periods, it can shorten the life expectancy of the unit's components. Avoid use at this setting for more than one or two hours at a time.

The convection blower speed varies directly with feed rate. The "High Fan" switch overrides this variable speed function. It will set the convection blower speed to high at any feed rate setting.

The "Manual Feed" switch allows you to add fuel to the burn pot automatically, **CAUTION: Do not use this control during normal operation as it could smother the fire and lead to a dangerous condition** (see section 3.92 a). During normal operation, this switch should be in its center position, neither on "HIGH FAN" or "MANUAL FEED".

3.5 OPTIONAL THERMOSTAT

A remote thermostat may help you maintain a constant house temperature automatically. A millivolt thermostat is required. When engaged, the stove will automatically switch between two settings. When warm enough, it will switch to "LOW", which also slows the convection blower. If the house then cools below your thermostat setting it will switch to the feed rate of your knob setting with a maximum rate of "D". The thermostat should be installed by a qualified service person.

NOTE: When using the thermostat, it is important to set your damper control rod at approximately half way between a "LOW" burn setting and your higher burn setting.

3.6 DAMPER CONTROL

The damper control rod on the stove's lower left side adjusts the combustion air. This control is necessary due to the varied burn characteristics of individual installations, different pellet brands and pellet feed rates. It allows you to improve the efficiency of your stove. Providing correct combustion air will reduce the frequency of cleaning your glass door and prevent the rapid build-up of creosote inside your stove and chimney.

You should adjust the damper based on the fire's appearance. A low, reddish, dirty fire can be improved by pulling the damper out slightly. A "blow torch" fire can be improved by pushing the damper in a bit.

As a general rule, on lower feed rate settings, the damper should be in farther. On higher feed rates, the damper should be more open. Through trial and error, you will find the best settings. Consult your dealer if you need help.

NOTE: On "LOW", damper should be out approximately 1/8"-1/4". If damper is out too far, it can cause the fire to go out.

3.7 REFUELING

We recommend that you not let the hopper drop below 1/4 full. **KEEP HOPPER LID CLOSED AT ALL TIMES EXCEPT WHEN REFILLING. DO NOT OVERFILL HOPPER.**

3.8 BRECKWELL MAINTENANCE TOOLS

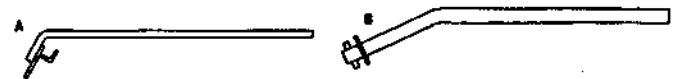

Tools have been provided to help with the following functions:

- a. Stir Pellets in Hopper — Unlike liquids in a tank, pellets do not drain evenly into the auger. Bridging across the opening can occur. Pellets can hang up on the sides of the hopper. Occasionally “stirring” the hopper can help. (Use Tool A)

NOTE: To help prevent bridging of pellets common wax paper can be rubbed on the sidewalls and bottom of the hopper.

- b. Ash Pan Removal — See instructions in section 4.1 (Tool A).
c. Cleaning Heat Exchanger Tubes — see instructions, section 4.2 (Tool B).
d. Scrape ashes from burn pot (Tool A or B).

3.9 SHUT DOWN PROCEDURE

Turning the Breckwell off is a matter of pressing the on/off control panel switch to off. The blowers will continue to operate until internal firebox temperatures have fallen to a preset level.

3.91 SAFETY FEATURES

- a. If there is a power outage longer than a few seconds, the auger will not operate once power is restored. This prevents pellets from being fed to a non-burning burn pot. Pressing the auger button on the panel control will reactivate the auger circuit. The blowers will come on when power is restored to evacuate the combustion chamber of gases and stay on until off switch is pushed.
- b. In case of a malfunctioning convection blower, a high temperature thermodisk will shut down the auger, preventing the stove from overheating. When stove has cooled, restart as instructed in sections 3.2 and 3.3.
- c. If the combustion blower fails, an air pressure switch will shut down the auger.

NOTE: Under some circumstances, opening the stove door during operation will cause enough pressure change to activate the air switch. Closing the door and depressing the “auger” button will restart the system.

3.92 OPERATING SAFETY PRECAUTIONS

- a. If you notice a smoldering fire (burn pot full but no visible flame) **AND** a heavy smoke build-up in firebox, pull plug on unit. Do not open the door, change the damper setting, or tamper with any controls on stove. Wait 15 minutes or until firebox clears, open door, plug unit back in and restart fire as instructed in sections 3.2 and 3.3)
- b. **DO NOT STORE OR USE FLAMMABLE LIQUIDS**, especially gasoline, in the vicinity of your Breckwell Stove. Never use a gas or propane torch, gasoline, gasoline-type lantern fuel, kerosene, charcoal lighter fluid or similar fluids to start or “freshen up” a fire in this heater.
- c. **WARNING: DO NOT OVERFIRE THIS STOVE.** This may cause serious damage to your stove and void your warranty. It also may create a fire hazard in your home. **IF ANY EXTERNAL PART OF THE UNIT BEGINS TO GLOW, YOU**

ARE OVERFIRING. Immediately press “off” switch on control panel.

- d. **KEEP ALL HOUSEHOLD COMBUSTIBLES, SUCH AS FURNITURE, DRAPES, TOYS, ETC. THREE FEET, OR A CONSIDERABLE DISTANCE FROM THE OPERATING STOVE.**
- e. Maintain proper ventilation. It is important that adequate oxygen be supplied to the fire for the combustion process. Modern houses are often so well insulated, it may become necessary to open a window slightly or install an outside air vent to provide sufficient combustion air.
- f. Since heating with a solid fuel fire is potentially hazardous, even with a well made and thoroughly tested stove, it would be wise to install strategically placed smoke detectors and have a fire extinguisher in a convenient location, near an exit.
- g. Do not open stove door when operating unless necessary. This will create a dirty, inefficient burn and could allow smoke spillage or sparks to escape.
- h. Do not permit operation by young children or those unfamiliar with stove’s operation.
- i. Do not service or clean this appliance without disconnecting power cord.
- j. Use only approved firestarters. These include gelled alcohol types and solid types with wax as an additive. Do not use solid types with paraffin, or liquids like barbecue lighter fluid, gasoline or rubbing alcohol. Do not use a gas or propane torch to light your stove.

4.0 MAINTENANCE

FAILURE TO CLEAN AND MAINTAIN THIS UNIT AS INDICATED CAN RESULT IN POOR PERFORMANCE AND SAFETY HAZARDS.

4.1 ASH DISPOSAL

The Cadet P26 and P32-I have dual ash pans. Remove ashes periodically as they fill the pan. To remove pan:

- a. Make sure fire is out and firebox is cool.
- b. Remove imitation log set, if in use. Remove burn pot by grasping and twist pulling straight out.
- c. Empty ashes from burn pot into pan. Scrape burn pot with tool A.
- d. Use tool A to lift pan(s) and pull out carefully (see figure 12).
- e. To replace, reverse procedure. Make sure burn pot is level and pushed all the way back in when it is reinstalled.

NOTE: Inspect burn pot periodically to see that holes have not become plugged. If so, clean thoroughly.

Ashes should be placed in a metal container with a tight fitting lid. The closed container of ashes should be placed on a non-combustible surface or on the ground, well away from all combustible materials pending final disposal. If ashes are disposed of by soil burial or otherwise locally disbursed, they should be retained in the closed container until all cinders have thoroughly cooled.

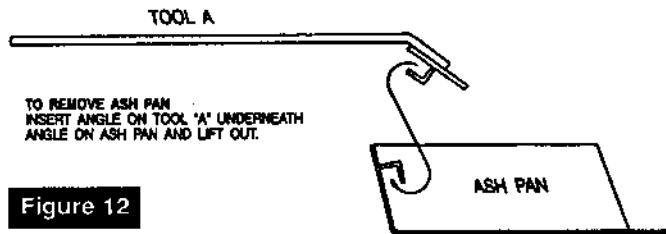
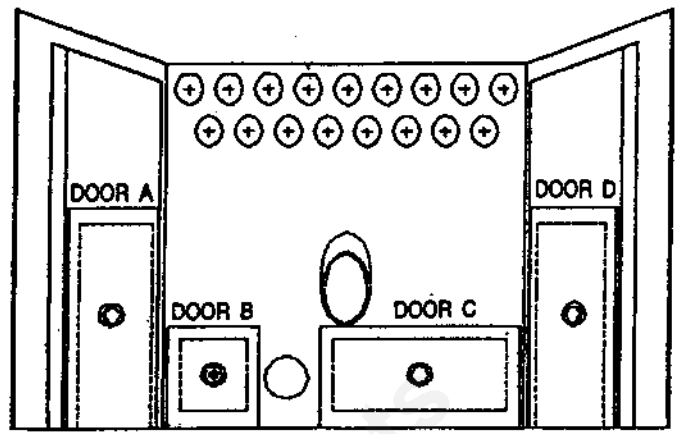

Figure 12



CADET P26

Figure 14

4.2 CLEANING

A. Heat Exchange Tubes — The Cadet is designed with a built-in heat exchange tube cleaner. This could be used every two or three days to remove accumulated ash on the tubes, which reduces heat transfer. Insert tool B in cleaner key (see figure 13), twist, move backwards and forwards several times. Leave tube cleaner at rear of stove.

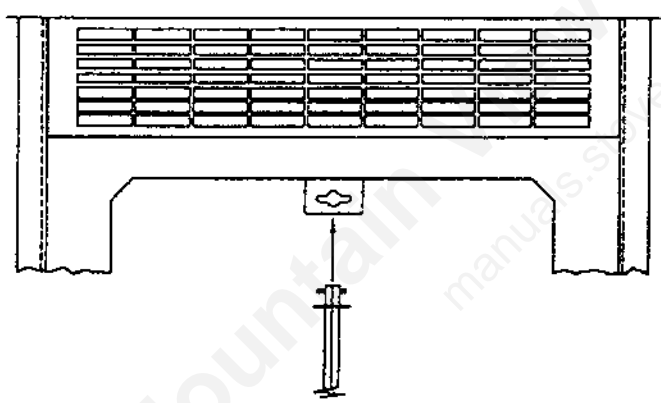

Figure 13

B. Interior Chambers — Four (4) cover plates in the firebox can be removed for periodic cleaning (see figure 14). All four doors allow access to the chamber surrounding the firebox.

Periodically, you must vacuum ashes from this chamber. In some cases you will need to remove creosote which can accumulate rapidly under certain conditions. A small wire brush can be used. It is important to remove this creosote since it is highly combustible. **INSPECT BEHIND THESE COVER PLATES AT LEAST ONCE PER TON OF PELLETS BURNED UNTIL YOU ARE FAMILIAR WITH HOW ASHES AND CREOSOTE ACCUMULATE WITH YOUR OPERATING PRACTICES.**

4.3 BLOWERS

a. **Cleaning** — Over a period of time, ashes or dust may collect on the blades of both the combustion blower and convection blower. Periodically the blowers should be vacuumed clean as these ashes can impede performance. Creosote can also accumulate in the combustion blower. This needs to be brushed clean. The Cadet P26 convection blower is accessed by opening the hinged left side door (facing stove) by removing two screws. The combustion blowers are accessed through door C (see figure 14). The Cadet P324 convection blower is accessed by pulling stove out of fireplace. The convection blower is on the left (facing stove), combustion blower on the right.

NOTE: Be careful when cleaning not to dislodge balancing clip on convection blower, or bend fan blades. Some stove owners lightly spray an anti-creosote chemical on the fire to help reduce creosote formation within the stove.

b. **Oiling** — Blower manufacturers suggest oiling annually. See figure 11 for lubrication points. Use SAE 20W motor oil. Limit to one or two drops.

4.4 CHIMNEY CLEANING

a. **Creosote Formation** — When wood is burned slowly, it produces tar and other organic vapors which combine with expelled moisture to form creosote. The creosote vapors condense in the relatively cool chimney flue of a newly started fire or from a slow burning fire. As a result, creosote residue accumulates on the flue lining. When ignited, this creosote makes an extremely hot fire which may damage the chimney or even destroy the house. Despite their high efficiency, pellet stoves can accumulate creosote under certain conditions.

b. **Fly Ash** — This accumulates in the horizontal portion of an exhaust run. Though noncombustible, it may impede the normal exhaust flow. It should therefore be periodically removed.

5.0 TROUBLE-SHOOTING GUIDE

c. Inspection and Removal — The chimney connector and chimney should be inspected at least monthly during the heating season to determine if a creosote or fly ash build-up has occurred.

If creosote has accumulated, it should be removed to reduce the risk of a chimney fire. Inspect the system at the stove connection and at the chimney top. Cooler surfaces tend to build creosote deposits quicker, so it is important to check the chimney from the top as well as from the bottom.

The creosote should be removed with a brush specifically designed for the type of chimney in use. A qualified chimney sweep can perform this service. It is also recommended that before each heating season the entire system be professionally inspected, cleaned, and repaired if necessary.

To clean the chimney, you can easily detach the vent at the combustion blower transition (see figure 15). Remove bolts. Make sure gasket is in place when re-attaching.

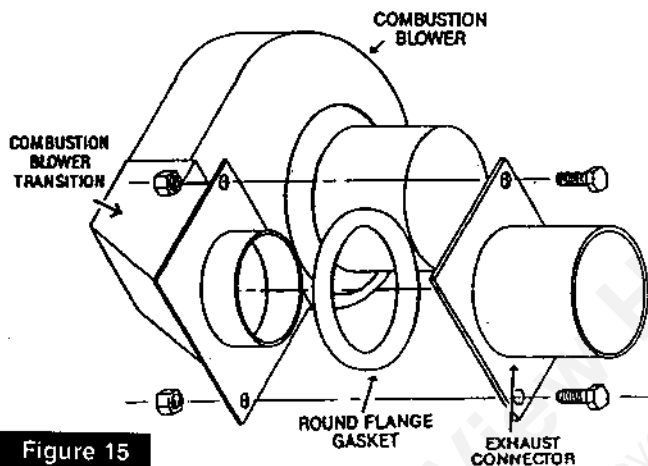

Figure 15

4.5 RECOMMENDED MAINTENANCE SCHEDULE

Use this as a guide under average use conditions.

	Daily	Twice Weekly	Monthly or per ton	Annually
Burn pot	stirred	emptied		
Clean Glass	wiped			
Combustion Chamber		brushed		
Ash Pan		emptied		
Exhaust Passage			vacuumed	
Heat Exchange Tubes		two passes		
Combustion Blower Blades			vacuumed brushed	
Fan Motors				oiled
Vent System				cleaned
Gaskets				inspected

Gasket around door and door glass should be inspected and repaired or replaced when necessary (see section 6.0).

When your stove acts out of the ordinary, the first reaction is to call for help. This guide may save time and money by enabling you to solve simple problems yourself. Problems can be due to only five factors: 1) poor fuel; 2) poor operation or maintenance; 3) poor installation; 4) component failure; 5) factory defect. You can usually solve those related to 1 and 2. Your dealer can solve those in 3, 4 and 5. Refer to figures 16, 17 and 18 to help locate indicated parts.

REMEMBER: Pull plug before servicing, unless otherwise instructed.

5.1 FUEL WILL NOT FEED

1. Check for fuel in hopper. See section 3.8a. If stove runs out of fuel, pellets will not feed once hopper is reloaded until auger fills with pellets. This takes several full turns of the auger. Hold manual feed switch on for 30-40 seconds.
2. Push "auger" button. Green light should come on.
3. Check for auger jam. Push the manual feed switch. If you can hear the auger motor trying to run but no pellets fall into burn pot you may have a jammed auger. Contact your dealer.
4. If auger motor is not working, and there is power to the system (green light is on) the auger thermodisk may be stuck in open position. Check the thermodisk with continuity tester. Auger thermodisk closes with heat rise. If problem persists, call dealer.
5. If vacuum in the stove is lost, an air switch shuts off the auger. Inspect for source of lost vacuum. Stove door ajar may cause this.
6. If a stove set at "MAX" is suddenly switched to "LOW", a temporary overheat condition may occur. This condition may stop the auger and cause the green light to go off. Press the "OFF" switch and the "HIGH FAN" switch. Allow stove to cool down and restart as instructed in sections 3.2 and 3.3

5.2 FIRE GOES OUT

(assuming auger is feeding and there is ample fuel in hopper and burn pot)

1. Check for blockage in combustion air inlet, burn pot and exhaust. With P32-I you can pull unit out 1/4" to allow more air into fireplace cavity.
2. Restart fire, adjust feed rate to higher setting. Large pellets feed more slowly. A fire sometimes CANNOT be maintained on low. If this problem recurs, either change to another brand of pellet fuel or do not set feed rate below "B".
3. Check to see if combustion blower is operating.

5.3 SMOKY FIRE (see section 3.6 first)

(reddish flame, soot deposits on door glass)

1. Check door and door glass gasket. Door should be tightly sealed. Replace gasket if necessary.
2. Check that burn pot is installed properly and holes are not plugged.
3. Check for blockage in combustion air inlet and exhaust (see 5.2, number 1).
4. Check quality of fuel (see section 3.1).
5. Adjust slide damper (see section 3.6).

5.4 NO POWER

1. Check power supply to stove.

5.5 BLOWERS WILL NOT OPERATE PROPERLY

1. Check power supply.
2. Check blower thermodisk with continuity tester. Blower thermodisk closes with heat rise.
3. Check combustion blower for creosote or ash buildup.

5.6 NOISY OPERATION

1. Identify source of noise (i.e. which motor)
2. Adjust tension of blower mounting screws if vibrating noise.
3. Check for dirty or unbalanced impeller wheel on blowers if clanging noise.
4. Oil blowers with SAE 20W motor oil. (1-2 drops only)
5. Readjust convection blower speed (pellet feed control knob), if harmonic vibration.

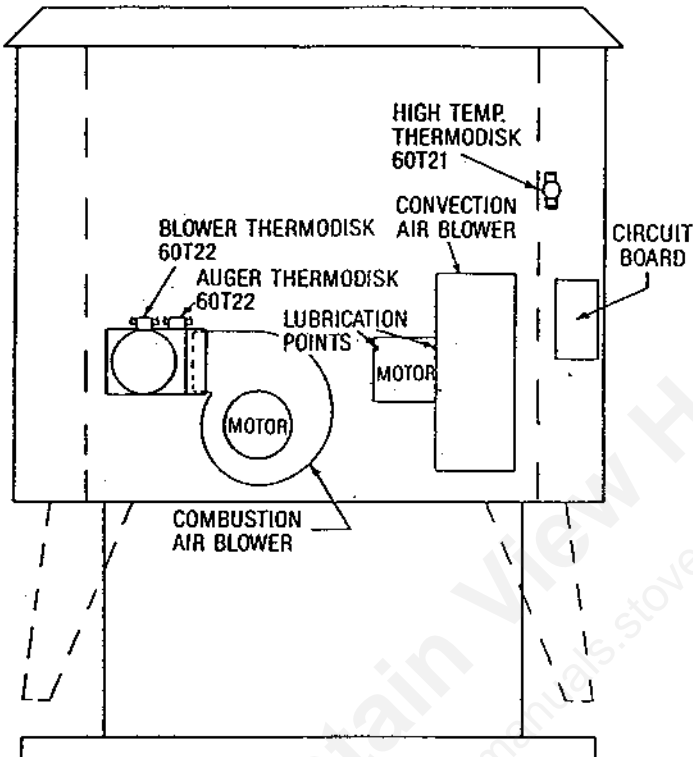

REAR VIEW
CADET P26

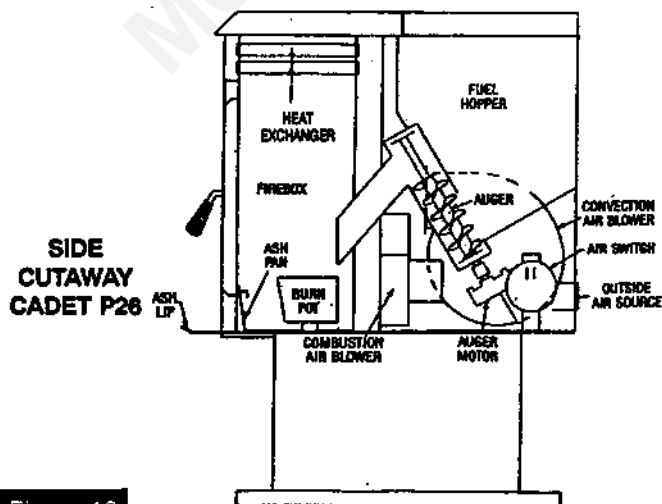
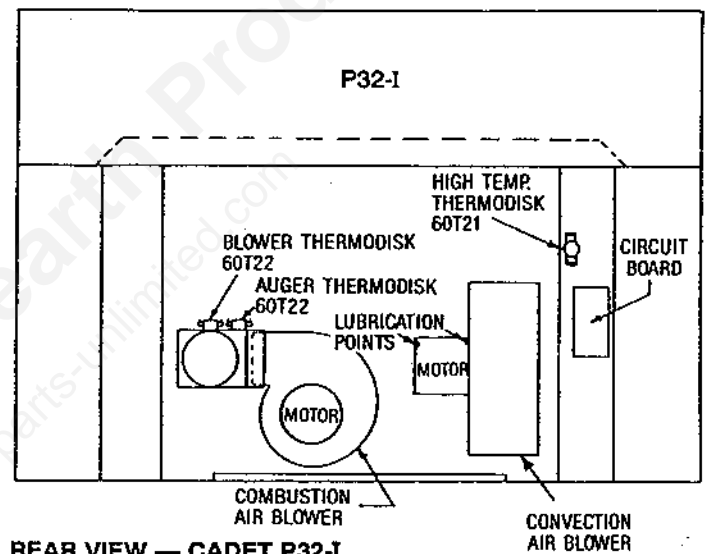
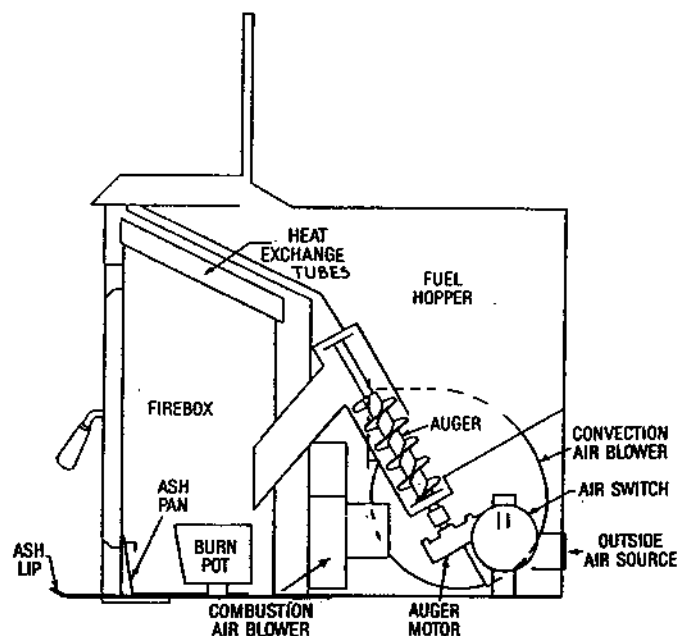

Figure 16



REAR VIEW — CADET P32-I



SIDE CUTAWAY — CADET P32-I

Figure 17

6.0 REPLACEMENT PARTS

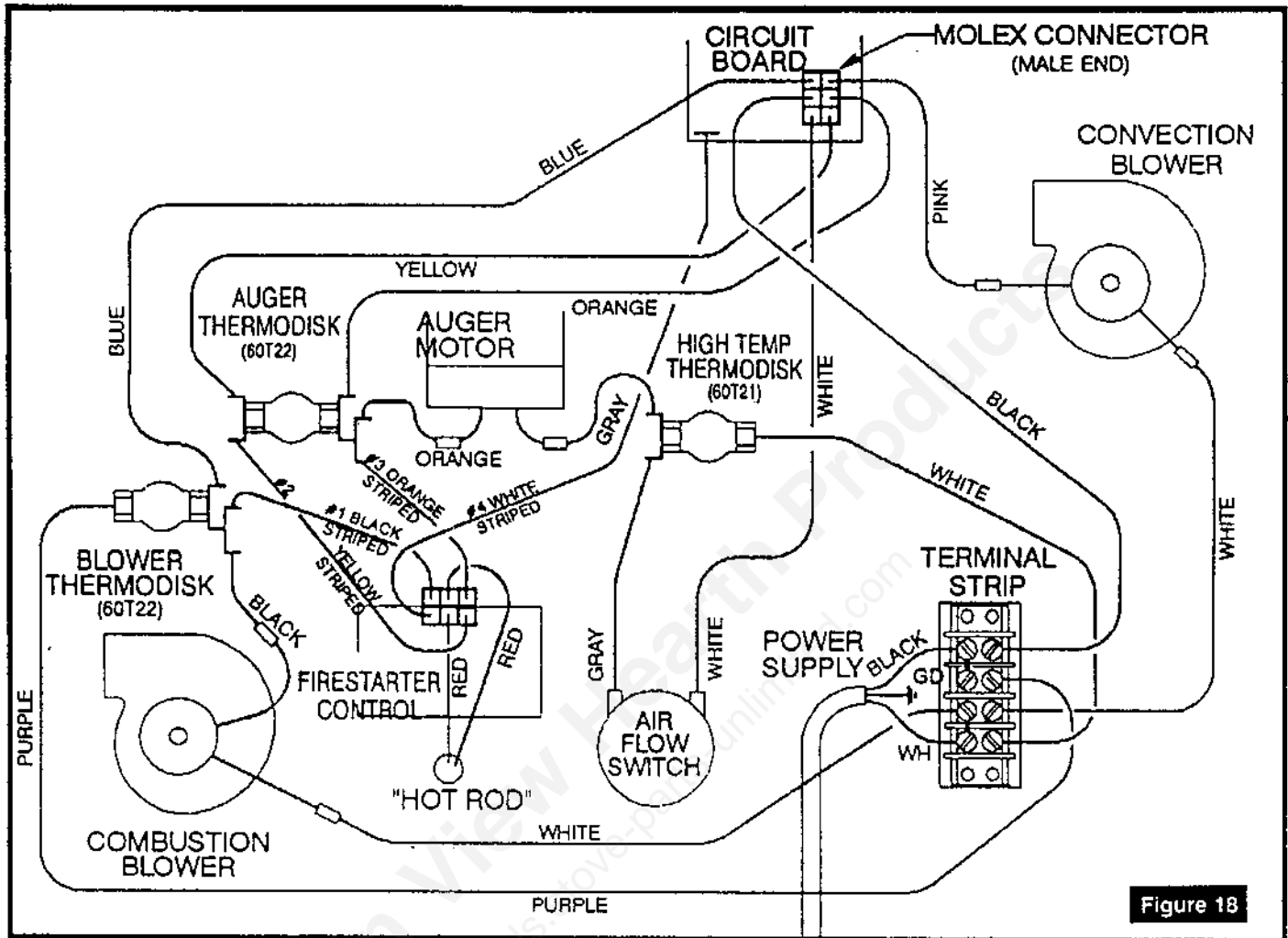

Figure 18

Contact an Authorized Breckwell Pellet Stove Dealer to obtain any of these parts

Item

Spring Handle	Auger Gear Motor
Door Glass	High Temp Thermodisk (T21)
Window Clips	Auger/Blower Thermodisk (T22)
Door Gasket (five feet)	Burn Pot
Window Gasket (five feet)	Breckwell Maintenance Tools (A and B)
Circuit Board/Control Panel	Furnace Cement (2-Oz.)
Convection Blower	Exhaust Adapter
Combustion Blower	Air Switch
Round Flange Gasket	

Optional Items for Your Breckwell

Check Valve
Imitation Firelog Set
4" Exhaust Adaptor
24-Carat Gold Plated Cowl
Brass Trim (P32-I)
Zero Clearance Skirt (P32-I)
Hot Rod Automatic Firestarter (A-HR)