

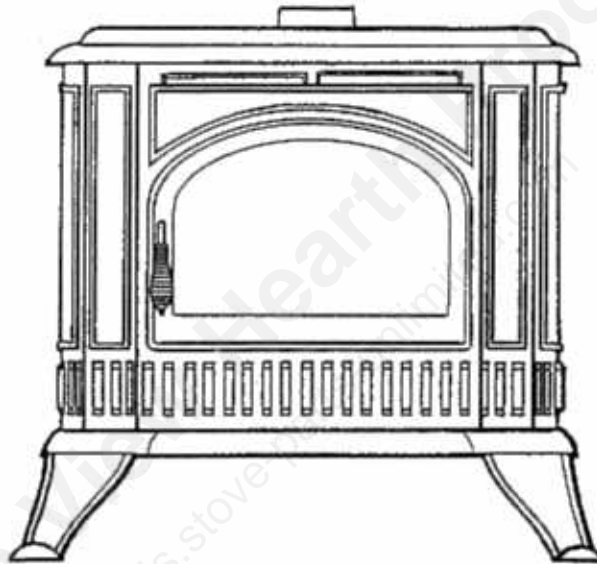

INSTALLATION AND OPERATION MANUAL



MODEL TP340



This equipment must be installed by a Qualified Technician
Read thoroughly before starting installation.
Save this manual for future reference.

Rev. 7/93

TABLE OF CONTENTS

Safety Notice	1
Introduction	2
Operation	4
Maintenance	8
Installation	12
Troubleshooting	18
Power Flow Diagram	20
Glossary	21
Specifications	22
Component Diagrams	23
Warranty	24

Mountain View Hearth Products
manuals.stove-parts-unlimited.com

IMPORTANT SAFETY NOTICE

PLEASE READ BEFORE ATTEMPTING TO BURN!

CAUTION: *If this stove is not properly installed, a house fire may result. For your safety, follow the installation directions; contact local building officials about restrictions and installation inspection requirements in your area.*

1. Installation of this stove must comply with local codes. A building or installation permit may be required. Be sure to check with your local building or fire department before installing.
2. Have your fireplace and chimney system inspected by a qualified person prior to installation of the stove. Make any necessary repairs before installing.
3. Never connect stove flue to chimney being presently used by another heater.
4. Never block any air intake or air outlet ports. Dangerous overheating can result.
5. Do not install this stove in a sleeping room.
6. Never connect the stove to an air duct system.
7. Never stack or pile combustible materials against the stove or around external vent termination.
8. To avoid burns, children and adults should be alerted to the hazards of high surface temperatures.
9. To provide reasonable fire safety, install a smoke detector and a conveniently located fire extinguisher.
10. In the event of a chimney fire, notify the fire department and unplug the stove and close all openings.
11. Terminate pellet vent pipe so that contact with humans or possible damage to pipe is avoided.
12. Required fuel is: 1/4" diameter pellets, 8500 BTU per pound, 10% maximum moisture content, 1%-3% ash. Corn kernels, 10,000 BTU per pound, 15% maximum moisture content (Optional Cornpot and metering cup filler plug required.)

Testing/Listing

This stove has been tested and listed for use in residential construction in accordance with the applicable portions of the following standards - UL1482, UL127, UL103 or UL641, UL507 and UL391 and for manufactured housing in accordance with OAR 814-23-900 through 814-23-909, by Pacific Inspection and Research Laboratory, Inc., (PIRL) Redmond, WA 98052.

Based on a tested air to fuel ratio in excess of 35:1, this appliance is not an effected facility under the EPA regulations for wood burning stoves.

INTRODUCTION

Read Entire Manual Before Attempting to Burn

OVERVIEW

Glass

The Glass is a super heat resistant ceramic that withstands continuous temperatures up to 1390° F. This temperature is well beyond the temperatures in which you operate your stove. After long periods of pilot operation some soot may form on the Glass.

Decorative Logs

An important feature of your NaturalFire stove is the realistic fire created by the flame spread Firepot and the refractory logs. Although the logs are quite durable, they should be handled carefully, as they retain heat for a considerable period of time, and if dropped can break.

Placement of the logs is important in achieving a realistic fire. One recommended pattern is pictured below which allows you to use a Firepot cleaner without having to remove the logs (except for full maintenance).

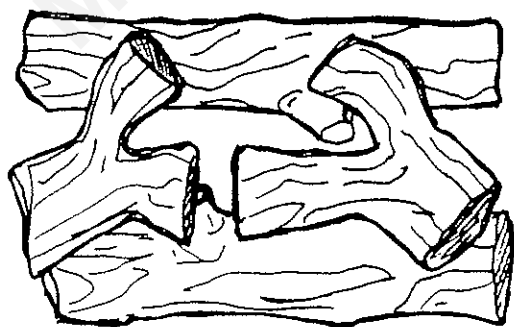

Hopper

The Hopper is where the fuel is stored before it feeds into the stove.

Firepot

The pellet Firepot is where the fuel is burned. Although it has a self cleaning capability for much of the ash build up, variable fuel quality (ash content) and extended periods of a low burn rate will necessitate some manual cleaning. An Earth Stove Firepot cleaning tool is highly recommended (part #1000).

Three Pronged Plug (Grounded)

Your stove has a printed circuit board and other electrical components that require a grounded circuit and proper polarity. Purchasing a surge protector provides additional insurance against unnecessary problems.

Control Panel/Fan Rheostat

The Primary Control Board (Model 1000) manages the performance of your stove. It allows you to regulate the fuel feed rate, the Draft Fan pilot and main power to the stove. The Room Air Fan Rheostat allows you to manually regulate the fan speed except when the automatic high speed override is engaged.

INTRODUCTION

OVERVIEW (Cont.)

HOW IT WORKS

The Fuel Metering Cup rotates in the throat of the Hopper providing a measured amount of fuel based on the set Feed Rate. The fuel drops into the Auger Tube where it is moved into the Firepot. The Draft Fan provides combustion air through the Auger Tube and a series of holes in the inner Firepot, to allow for complete combustion.

The flame and hot gases provide heat to the Heat Exchange Tubes located in the upper chamber of the stove. The Room Air Fan(s) extracts the heat and delivers it to the room, along with the natural radiant heat from the glass and metal surfaces.

OPTIONS

Several options are available to enhance your NaturalFire pellet stove. Please see your local dealer for further information.

Marble Set (Top/Hearth)

Marble is a natural product so each piece will have its own unique character. Marble may be cleaned with a damp cloth to remove oils or dust. Be sure to install the four cerawool strips (under the marble) to protect it. Do not put rough objects (such as trivets/steamers /hopper lids) on the surface. Do not install the Marble before curing the paint.

Remote Thermostat

One way to maximize the efficiency and convenience of your stove is to install a remote Thermostat. A Honeywell T87F 24 volt Thermostat is recommended.

Hopper Extension

To increase the amount of fuel available for use in the Hopper, a Hopper Extension is available. The Hopper Extension sits on top of the existing Hopper, and has the capacity to hold approximately 40 additional pounds of pellet fuel.

Corn Pot

NaturalFire pellet stoves will burn most types of corn with the addition of a Corn Pot kit. For details, see the section on Burning Corn.

OPERATION

Before Attempting To Start Your Stove, Read This Manual Thoroughly.
Have Your Stove Pretested and Professionally Installed.

Start Up Procedure

1. Plug in the stove. Fill hopper with pellet fuel.
2. Turn the Main Power Switch to the "Feed System" position.
3. Provide starting fuel by pushing the "Start Button" and allow fuel to feed for approximately five minutes (or put approximately two cups of fuel directly in the Firepot).
4. Turn the Main Power Switch to the "Stove Off" position. (This will stop the fuel feed.)
5. Open fire door and apply Fire Starter gel to the fuel in the Firepot, then light. Allow the fuel to burn for five minutes with the door slightly ajar.
6. Close the door.
7. Turn the Main Power Switch to the "Feed System" position, then push the Start Button.
8. Set the Fuel Rate Switch to the "Full" position. If using a remote Thermostat, adjust it to the desired room temperature.
9. As the stove temperature rises, the Room Air Fan(s) will automatically engage. At that point, adjust the Fuel Rate Switch to the desired setting. During the start up procedure or when running the stove on a "Low" Fuel Rate Setting, the Room Air Fan Rheostat must be in the off position. Failure to do so could cool down the stove and it will automatically shut off.
10. If the fire goes out, go back to step two again.

Shut Down Procedure

1. Turn the Main Power Switch to the "Draft Fan" position. If using a remote Thermostat, turn the Thermostat down.
2. When the fire in the Firepot goes out completely, shut the Main Power Switch to the "Stove Off" position.

OPERATION

Control Board Model 1000

A. Main Power Switch

The Main Power Switch is a three way toggle with the following positions:

1. Stove Off
2. Draft Fan - allows the Draft Fan to operate alone during shut down.
3. Feed System - Stove On

B. Fuel Rate Switch

The Fuel Rate Switch controls the amount of time the burner feeds fuel. It can be set to the following three positions:

1. Full - will feed fuel continuously.
2. Medium - will feed fuel approximately two minutes on then two minutes off.
3. Low - will feed approximately one minute on then three minutes off.

C. Draft Fan Switch

The Draft Fan Switch controls the amount of air used for combustion and aids in the draft of the stove. It can be set to the following three positions:

1. High - runs at 75% of capacity when stove is not feeding fuel.
2. Low - runs at 50% of capacity when stove is not feeding fuel.
3. Off - runs at 0% of capacity when stove is not feeding fuel.

NOTE: The Draft Fan will run at 100% of capacity during the feeding of fuel after the stove has reached normal operating temperatures.

D. Start Button

Depress the Start Button to allow fuel to feed for approximately 12 minutes (used during the start up of the stove).

E. On/Off Light

The On/Off Light blinks to indicate electricity is flowing through the Primary Control Board.

F. Fuse

The Fuse protects the Primary Control Board from power "surges or spikes".

G. Room Air Fan Rheostat

The Room Air Fan Rheostat can be used to vary the speed of the Room Air Fan by rotating it to the desired setting. When the stove is very hot, the Rheostat override (Fan Speed Disc) will automatically run the fan on high until the stove cools.



OPERATION

Normal Operating Sounds

Heat Exchange Tubes - As the Room Air Fan(s) increase in speed, you may hear air being forced through these tubes and out into the room.

Thermostatic Control Disc - There are four different heat activated temperature discs on the stove. The discs can make a light clicking sound as the stove heats up or cools down.

Room Air Fan(s) - The modern, high efficiency fan may have a hum or pulsating sound, particularly on the high setting. The sound may change as the fan speed is varied.

Auger Feed System - When fuel is fed from the Hopper to the Auger Tube, a light clinking sound or the fuel being cut may be heard.

Auger/Cup Motor(s) - When feeding fuel, you may hear the intermittent buzz or hum of these motors.

Draft Fan - This motor runs at various speeds to provide combustion air to the Firepot (and to aid in the draft of the flue). The speed of this motor will increase with the feeding of fuel.

Optional Remote Thermostat

One way to maximize the efficiency and convenience of your stove is to install a remote Thermostat. A Honeywell T87F 24 volt Thermostat is recommended.

Follow the manufacturer's installation instructions using 18/2 stat wire. The leads from the stove are the yellow wires found behind the Primary Control Board.

Once you have installed the Thermostat, the Fuel Rate Switch should be set to "Low". This will be the rate the stove will pilot at when the Thermostat is not calling for heat.

OPERATION

BURNING CORN (Optional)

Natural Fire pellet stoves will burn most types of corn with the addition of a Corn Pot kit. It is not necessary to mix corn with wood pellets however, wood pellets are required to start the fire. NOTE: Burning treated seed corn is never recommended.

The Corn Pot kit consists of:

- 1 1/8" Filler Plug
- 1 3/8" Filler Plug
- 1 Corn Pot

To install the Corn Pot, simply remove the screw(s) from the top of the Auger Housing and lift up and out on the Firepot. Slide mounting flange of the Corn Pot over the Auger Housing and replace screw(s).

Initially the Air Shutter on the Draft Fan should be set at 1/2 open and the Draft Fan selector on "LOW". If more or less combustion air is needed, adjust the Air Shutter accordingly to achieve a bright yellow flame.

Because corn size and density varies, it will be necessary to calibrate the Fuel Metering Cup in order to maintain rated BTU input and prevent overfiring. This requires the installation of the Filler Plug in the Fuel Metering Cup. Use the 1/8" filler plug provided in the Cornpot kit.

The moisture content of the corn should be 15% or less, and care should be taken to ensure that there are no foreign objects in the corn (i.e. sticks, stalks, cob parts, etc.).

When burning corn, the primary combustion takes place on a bed at the bottom of the Corn Pot. The Corn Pot has a solid bottom and sides with air holes because burning corn forms a fluid-like residue which becomes solid when cool. The Corn Pot cleaning will depend upon the quality and quantity of corn being used. The Cornpot should be cleaned when the build up starts to reach the bottom air holes inside of the Cornpot. You will need to remove the ash, and in some instances a white calcium like deposit. The stove must be shut down and cooled before cleaning.

Corn burning should be done in top vent installations only. If the installation must elbow into a wall thimble, the horizontal run should not be more than 24". The use of a wall mounted Thermostat, part #CTR140 is suggested.

Start Up Procedure

We recommend starting a corn fire with wood pellets because corn has a dense shell that can be difficult to start. Manually fill the Cornpot, to the bottom of the Auger Tube, with wood pellets. Use of the Start Button feature is not recommended when initially starting the unit for corn burning. (See "Start Up Procedure" in the Operation section for additional start up information.)

MAINTENANCE

Ash Removal and Disposal

CAUTION: BE SURE THE FIRE IS OUT AND STOVE IS COLD BEFORE REMOVING ASHES! NEVER BURN YOUR STOVE WITH THE DOOR OPEN.

Ashes can hold live embers for several days, and must be disposed of with care. NEVER place ashes in a cardboard box or any other combustible receptacle. Place the ashes in a metal container with a tight fitting metal lid. The closed container should be stored on a noncombustible surface, away from combustible materials. Keep the ashes in the closed container until you are certain all the cinders have completely cooled.

Door Gasket

A spun fiberglass gasket (3/4" in diameter) provides the seal around the fuel door. Should this become frayed or damaged it should be replaced. Spun fiberglass "rope" gasket can be purchased from your dealer or some hardware stores. It must be the same diameter as the original. Use high temperature (RTV) silicone sealer as an adhesive.

WARNING: MAINTAIN THE DOOR SEAL IN GOOD CONDITION. DO NOT LEAVE THE STOVE BURNING WITH THE DOOR OPEN OR AJAR.

Fan(s)

At least once each year, check the Room Air and Draft Fans inlets for deposits from carpeting, pet hair, furniture coverings, etc. Use a brush and/or light vacuuming for cleaning. Oiling the fans is not necessary.

Creosote Formation and Need for Removal

If your stove is properly adjusted, very little creosote will develop in your flue system. If creosote begins to develop, it is likely that poor adjustment or needed maintenance is causing incomplete combustion of the fuel. Be sure your Draft Fan Switch, and Draft Fan shutter are set properly.

What causes creosote is the moisture content of the fuel versus the rate at which it is burned. Piloting a stove on low feed rate for long periods of time, causes incomplete combustion, creating vapors which may condense in a relatively cool chimney, thus forming creosote. Also, creosote deposits tend to form in long runs of venting where gases cool prior to exhausting.

Soft fly ash is a normal by product of burning pellet fuel, and can accumulate in your flue system. Using lower grade fuel will increase the frequency of cleaning that will be needed. Check your flue regularly (at least once a month) until a schedule can be established for your installation and fuel quality. Remember, during high use periods to increase your inspection cycle.

Note: Single wall pipe cools rapidly and is therefore more susceptible to creosote deposits.

Paint

Your stove finish is a high temp paint that requires time and temperature to completely cure. Depending on your use, this may take a few hours or a few days. Do not attempt to repaint the stove until the paint is completely cured. Do not place anything on the stove surface until the stove has gone through several heat up/cool down cycles, as the paint will become soft before it cures.

MAINTENANCE

Firepot

Keep the Firepot inner holes free of obstructions (buildup). Pull the Firepot and empty it when this occurs. The quality and quantity of pellets used will dictate the necessary cleaning. Remove clinkers or carbon build up.

Clinkers are a byproduct of the fuel. Silica (or dirt) in the fuel, along with other impurities can fuse under heat and cause clinkering. Clinkering is a function of the fuel, not the stove. A clinker should be removed using a clean out tool.

Refractory Logs

The following steps will insure the longevity of your logs:

1. Never attempt to handle them while they are hot.
2. Use a "Natural Fire" Firepot cleaner tool (Part #1000) to remove ashes from the Firepot. In many cases you can do this without removing any logs. Except when cleaning out the bottom of the stove and firepot, do not remove the large 1/4 Logs.

Cleaning the TP340

1. Turn the unit off two to three hours before cleaning to allow the unit to cool (see Shut Down procedure).
2. Place protective floor covering around the front of the stove.

3. CAREFULLY remove the decorative logs from the Firebox and set them aside.
4. Remove the Firepot by removing screw(s) from the auger housing and pulling up and out.
5. Remove the ashes and empty into your noncombustible container. Dispose of ashes as previously described (see ash removal and disposal). Clean any remaining ash from the Firebox area.
6. After the stove chimney has been swept, remove the rear chimney seal off plate (if top vented), or the top chimney seal off plate (if rear vented). Vacuum the unit out, through the opening. There is a upper Baffle Plate (see page 10).
7. between the top of the Heat Exchange Tubes and the top of the stove there is a baffle plate (see page 10). Fly ash will accumulate on this plate and must be removed or your flue will become clogged. You can use a small diameter hose down through the top vent outlet or remove the (2) 13 millimeter bolts on either side of the top, and pull the top. Be sure to regasket the top before you reinstall it.
8. Remove the dust and fly ash which accumulates on the Heat Exchange Tubes.
9. Reinstall your Firepot being sure that the Auger Tube protrudes about 1/8" into the Firepot. Reseal and secure stove chimney.
10. The cleaning frequency will be dictated by the quality and quantity of the fuel burned. The following is the suggested minimum: After every 1 ton of pellets. When the metal surfaces of the exchange tubes are no longer visible. After every 2-3 weeks of use.

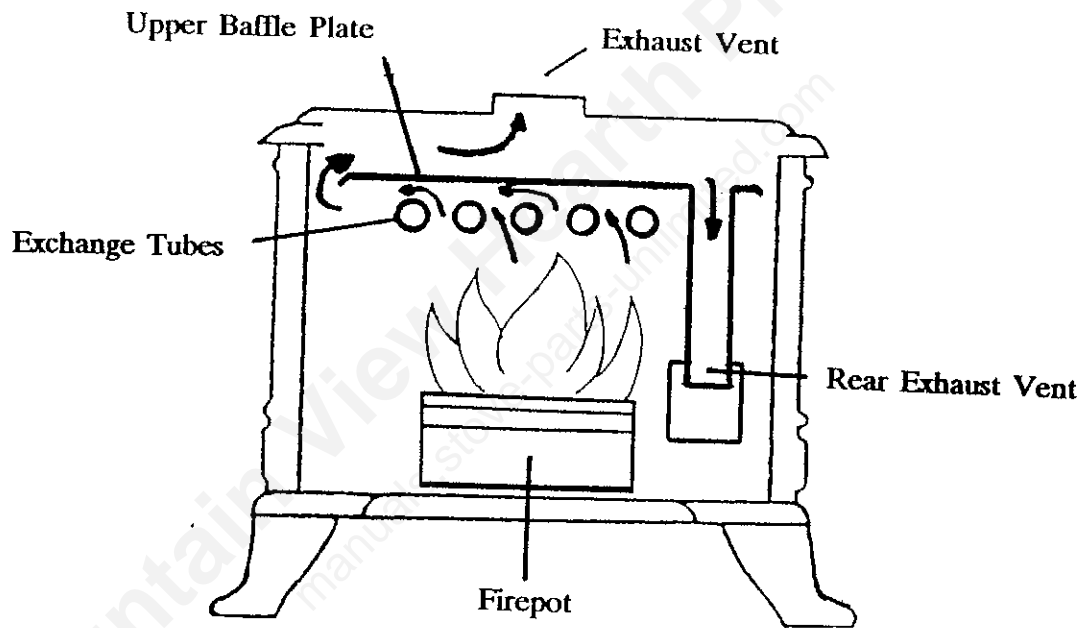

MAINTENANCE

Maintenance Suggestions

As with all appliances, periodic maintenance is required to keep them operating at optimum efficiency. We recommend an annual maintenance service by a qualified technician.

Recommended Maintenance Points

- A. Once for every ton of fuel burned, use a brush and remove all dust and fly ash from Heat Exchange Tubes and Baffle areas.
- B. Remove and clean the Firepot. Keep inner air holes free from buildup. Remove ashes from the Firebox weekly or as often as fuel dictates.
- C. Clean chimney, cap and exhaust passage way annually or as needed. Inspect monthly.
- D. Vacuum air intakes and squirrel cage on Room Air Fan(s) annually.
- E. Clean squirrel cage on Draft Fan annually.
- F. If remote Thermostat is used, remove cover and clean contacts annually.
- G. Replace Door Gasket as needed.
- H. Replace Ash Drawer Door Gasket as needed.

Maintenance Related Problems

Problem: Decrease in heat output or incomplete combustion.

Solution: See maintenance points A, B, C, D and E (above).

Problem: Decrease in Room Air Fan(s) velocity.

Solution: See maintenance point D (above).

Problem: Stove smokes or odor in home.

Solution: See maintenance points A, B, C, G and H (above).

Problem: Flames appear to burn lazily.

Solution: See maintenance points A, B, C, and E (above).

Problem: Noticeable change in Room Air Fan(s) noise.

Solution: See maintenance point D (above).

If solutions fail to cure problem, See Trouble Shooting Section.

INSTALLATION

Recommended Pre-Installation Procedure

NOTE TO INSTALLER: Before the unit is installed it is recommended that the unit be pre-burned to verify the operation, to burn off oils that are sometimes found in the Heat Exchange Tubes, and to cure the paint. The "Pre-Installation Procedure" should be done in a well ventilated area as follows.

1. Plug the stove into a grounded outlet. (Using a circuit tester verify the electrical outlet for proper ground and polarity where the unit will be installed. Failure to do so could result in damage to the electrical components and void the warranty.)
 2. Check the shutter on the Draft Fan and make sure it is set at 1/2 open. (once installed the actual setting will depend upon the draft of the flue.) On the Primary Control Board, A) set the Main Power Switch from "Stove Off" to the "Draft Fan" position and B) put the Fuel Feed Rate on "Full". The Draft Fan should now start. Open the door, place your hand over the Firepot and see if the Draft Fan is forcing air into the Firepot. Turn the Main Power Switch to the "Stove Off" position.
 3. Turn the Rheostat "On" to see if the Room Air Fan(s) run. After checking the fan(s), turn the Rheostat "Off".
 4. Look down into the Hopper, and make sure nothing is obstructing the Fuel Metering Cup. Pour 1/4 bag of pellets in the Hopper.
 5. With the Main Power Switch in the "Feed System" position, push the Start Button. Allow fuel to feed for approximately five minutes. Put the Main Power Switch in the "Stove Off" position. Apply non-volatile lighting material to the pellets and light it with a match. Let the fuel burn for five minutes leaving the door slightly ajar.
 6. Close the door and set the Main Power Switch to the "Feed System" position, and the Fuel Rate Switch to the "Full" position. Push the Start Button. The Draft Fan will run at high and the flame will increase (a full flame will need to be established in the Firepot before normal operation can be maintained).
 7. Once running, observe the stove operating for 15-30 minutes.
 8. As the stove temperature rises, the Room Air Fan(s) will automatically be engaged. Set the Rheostat to the desired speed.
 9. If necessary, adjust the Draft Fan Shutter to bring the fire to a bright yellow flame (approximately 1/2 open).
 10. Once the stove is operating properly, complete filling the Hopper and run the unit for 30 minutes.
-

CLEARANCES

The termination of the outside chimney of the pellet stove shall be located in accordance with the following:

1. Higher than 3 ft. above any forced air inlet (air conditioner, etc.) located within 10 ft.
2. Not less than 4 ft. below, 4 ft. horizontally from or 1 ft. above any gravity air inlet (door, window, etc.).
3. Not less than 2 ft. from an adjacent building and not less than 7 ft. above grade when located adjacent to the public sidewalks (access).
4. Not less than 3 ft. below an eave or any construction that projects more than 2" from the plane of the wall.

Note: Do not use class B venting intended for gas appliances as a chimney or connector pipe on a pellet fired unit.

Minimum Clearances to Combustibles

Side: 12"
 Back: 1"
 Front: 48" horizontal from door

Single Wall pipe: 9"
 Maximum horizontal run: 36"
 Offsets allowed: 2

Alcove Clearances *

The TP440 pellet stove may be installed in an alcove with the following minimum clearances:

Alcove height: 72"
 Side Wall Clearance: 12"
 Back Wall Clearance: 1"

The stove cannot be recessed into the alcove more than 6" from the face of the stove to the plane of the opening of the alcove.

Floor Protection

If placing units on a combustible surface, the following requirements must be met:

In Residential and Mobile Home Installations, the floor protection must cover the area beneath the stove and extend one inch beyond the base on all sides.

Corner

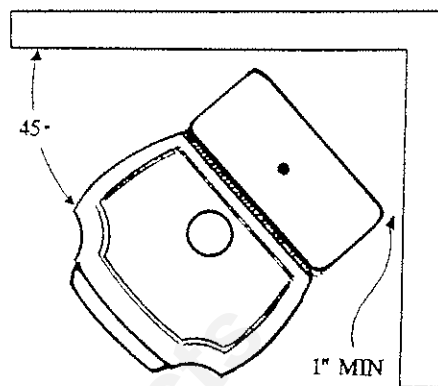

Rear Wall or Alcove

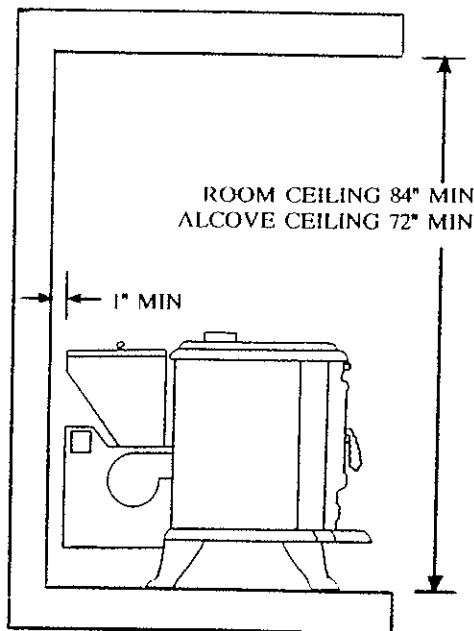
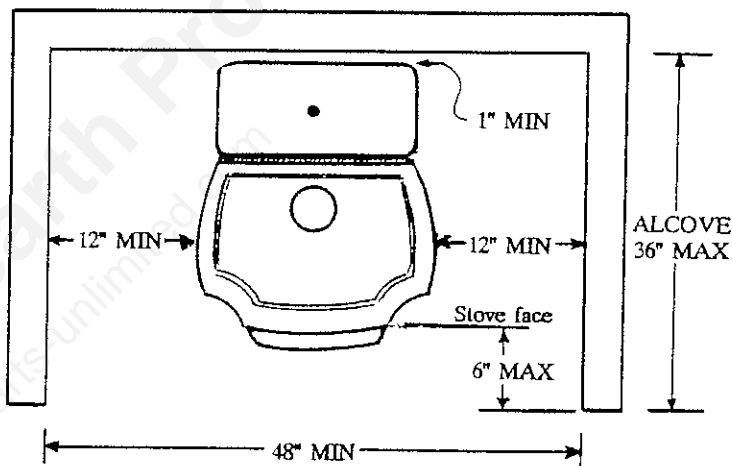

* IF INSTALLED TO THE MINIMUM SIDE AND REAR CLEARANCES IN AN ALCOVE, REMOVAL OF THE APPLIANCE MAY BE NECESSARY FOR SERVICING.

INSTALLATION

Venting Requirements

There are several options for the installation and venting of your pellet stove. Refer to clearances before installing your stove.

Connect only one flue per appliance. When passing through walls or ceilings, The manufacturer recommends that clearances are maintained in accordance with NFPA 211. Do not downsize your connecting pipe or chimney.

Your NaturalFire pellet stove must be connected to a 4" pipe. UL listed pellet vent is a preferred type of pipe, or a single wall 26 gauge minimum. Follow the pipe manufacturers installation instructions and clearances. All pipe joints must be sealed with the compound supplied with the pipe or a RTV silicone with a rating of at least 570°F.

You may connect the single wall or pellet vent to the top of the stove using three screws to secure it to the collar. Use a RTV silicone with a rating of at least 570°F, or interam to provide a complete seal.

Direct Vent

Although a direct vent flue is an approved installation, the manufacturer does recommend that to eliminate the possibility of siding discoloration and/or to enhance performance in bad draw situations, the outside flue should be installed with a "T", and Pellet Vent chimney pipe run up through the eave. Terminate the pipe using the standard clearance. Exception: if using a UL listed Pellet Vent pipe you may use the Pellet Vent manufacturer's clearances.

If burning corn, direct vent is not an approved installation.

IMPORTANT!! Never turn the Draft Fan Selector to the "OFF" position on any direct vent installations. Keep the Combustion Fan Switch on the Primary Control Board in the "Low" or High" position. In the event of a loss of power in a rear vent direct termination application, natural draft is not present and you will experience smoking, but this will dissipate rapidly.

1. Remove the top vent outlet.
2. Place the cover plate (A) over this opening. Make sure the gasket (B) is in place and there is a complete seal. Replace bolts and tighten.
3. Remove the rear vent cover located on the back of the stove.
4. In its place, install the gasket (B) and starting collar (C) making sure the gasket center has been cut out to allow flue gas to pass through the collar. Replace bolts and tighten.
5. Attach section of pellet vent pipe (D). Seal this connection with high temperature silicone sealant. The horizontal run may not exceed 36 inches.

A rear breach kit is available through your dealer, part number RBK40. It consists of the A) top vent cover plate, and C) 4" starting collar.

- A) Top Vent Cover Plate
- B) Gasket Material
- C) 4" Starting Collar
- D) 4" - 24" section
- E) 4" Wall Thimble
- F) 4" Rain Cap

INSTALLATION

Direct Vent

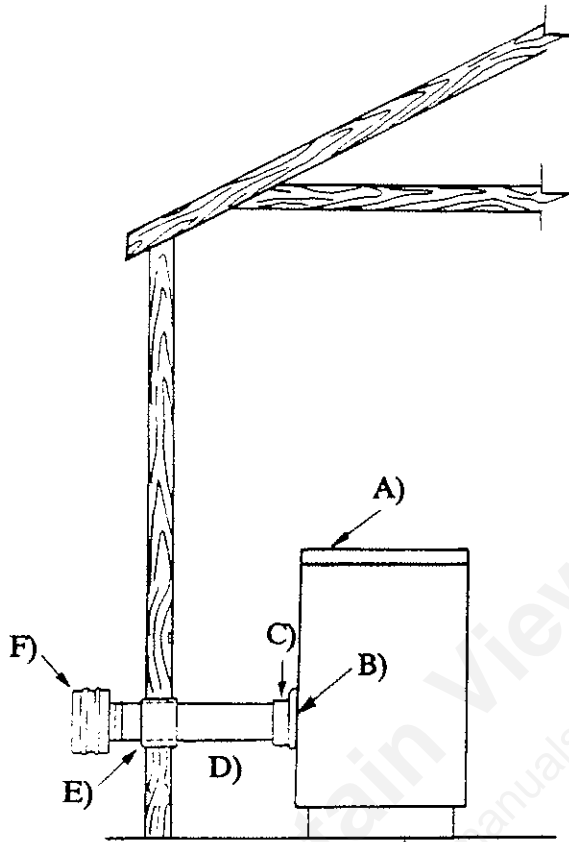

Standard

The most desirable installation is connecting Pellet Vent up to the top of the stove and running it up through the ceiling. Terminate the Pellet Vent above the roof line. Be sure to follow all clearances listed by the pipe manufacturer.

Connection To A Masonry Chimney Through A Wall

Be sure to verify the construction of a masonry chimney, as many have combustible framing. Follow the pipe manufacturer clearances.

An oversized chimney or high altitude may result in less than optimum performance. Installations into a large, masonry chimney may require a liner to improve performance. The use of single wall flex or rigid (26 gauge galvanized or stainless steel) pipe as a liner is approved.

Connection To An Existing Class A Chimney

An adaptor can be used to make the connection from 4" Pellet Vent pipe to existing UL chimney system. Verify with the pipe manufacturer that your pipe brands will interconnect. Installations into a large UL chimney system may require a liner to improve performance. The use of single wall flex or rigid (26 gauge galvanized or stainless steel) pipe as a liner through a UL class "A" chimney is approved.

INSTALLATION

Mobile Home Installation Requirements

Installation of the TP340 in a mobile home must follow the instructions for residential installation, with the following supplemental requirements:

1. No single wall pipe may be used. Pellet Vent pipe must be used from stove top to termination.
2. Offsets permitted: Maximum two offsets.
3. The chimney must provide for a section joint so that any parts extending above 13' 6" from ground level can be removed for transportation of the mobile structure.
4. The stove must be grounded to the mobile home trailer frame with a No. 8 (minimum) solid conductor.
5. The combustion air must communicate to the outside air.
6. Floor protection beneath the unit is required, but does not have to extend past the body of the stove.
7. Structural members such as roof trusses or floor joists cannot be cut or modified while making the installation.

Outside Air Provision

Although this section applies to a mobile home installation, it may also be required by local codes in standard residential installations. Use the manufacturers optional outside air kit (part #85-35) or equivalent.

1. Set the stove in its installed position and select the floor or outside wall location for the outside air penetration. The air ducting must connect with the bottom of the motor cabinet of your stove, using rigid or flexible 3" duct.
2. Cut an opening for the outside air kit (Part #85-35).
3. Install the outside air kit.

INSTALLATION

Examples of Installation Applications

Direct Vent Termination

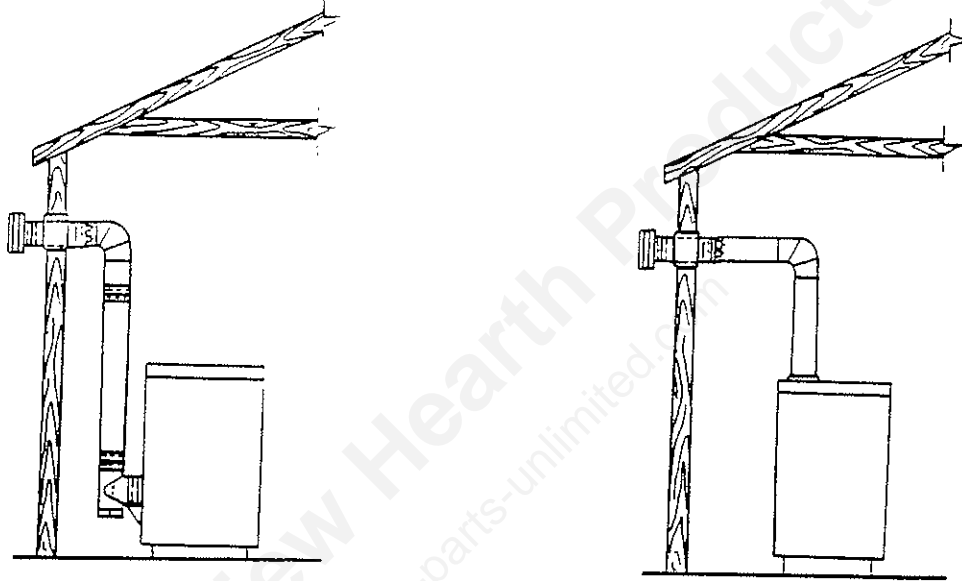

Direct Vent Using A "T"

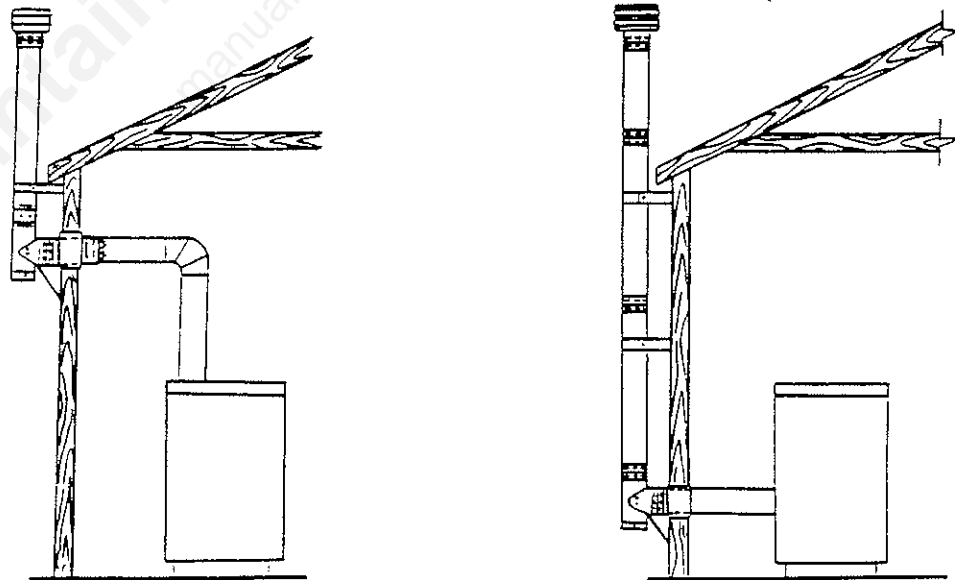

SIX STEP TROUBLESHOOTING GUIDE (*Qualified Technicians Only*)

Tools Essential For Troubleshooting

1. Stove Installation and Operation Manual.
2. Circuit Tester (Micronta # 22-101 or equivalent).
3. Molex Pin Extractor, 1/8" (p/n # 15068).
4. Volt Meter.

ATTENTION: Before attempting any troubleshooting; 1) Check your outlet to see that you do have power and the outlet is wired properly (use circuit tester); 2) Check the flue for blockage; 3) Take the time to clean the stove; 4) Note the model number of the primary control board (if a model number is not printed on the face of the primary control board, it is a model: Emerson.)

Step #1

Room Air Fan System Check

Turn the rheostat knob till it "clicks", it is now "ON". In this position the room air fan(s) will operate at full speed (115v). Place your hand in front of the air outlet to confirm that air is coming out. Further rotation of the knob will slow the speed of the room air fan(s). On the lowest setting the fan(s) receives approximately 65 volts. If the room air fan(s) comes on and operates properly (as described), the source of the problem will not be the rheostat, room air fan(s), fan speed disc, wiring connections or circuitry.

Should the room air fan(s) fail to come on, the first step in finding the problem is to check the power source (using a circuit tester or simply plug a lamp or other small appliance into the outlet). Once it has been determined that there is power to the outlet, the room air fan motor can be checked by removing the leads from the molex connector and connecting them to a 115v power source. If the room air fan(s) run, the problem is a loose connection. If the room air fan(s) fail to run, replacement will be necessary.

Step #2

Confirm Power to Primary Control Board

Turn main power switch from the "OFF" position to the "DRAFT FAN" position. If the red indicator light comes on, there is power to the primary control board. If the light does not come on, check the following:

- A. Power source (see Step #1)
- B. Fuse
- C. High limit manual reset discs
- D. High limit auto reset disc

If the fuse is not blown and the high limit manual reset disc has not "popped out", inspect the molex connectors and be certain the pins are making proper contact. Then, using a volt meter, check for power at the power switch. If the volt meter indicates 115v and the red indicator light is not on, it will be necessary to replace the primary control board.

SIX STEP TROUBLESHOOTING GUIDE

(Qualified Technicians Only)

Step #3 Confirm Draft Fan Operation

Set the main power switch to the "DRAFT FAN" position then set the fuel rate switch to the "FULL" position. The draft fan should now operate at full power (aprox.115v). During the piloting process, the draft fan will operate at the following speeds:

Switch Position	Voltage
High	70-75v
Low	60-65v
Off	0v

To check the daft fan when the stove is cold, check for movement of air by placing your hand in or near the firepot. If the movement of air is not obvious, inspect the draft fan to be certain the air shutter is open. If the air shutter is open and the draft fan is not running, check it by using the procedure in Step #1, paragraph 2.

Step #4 Inspect Fuel Metering Cup for Blockage

To inspect the fuel metering cup, **FIRST**:

- **UNPLUG THE POWER CORD.**
- **NEVER PUT YOUR FINGERS IN THE FUEL CAVITY OF THE METERING CUP.**

Remove all the fuel from the hopper. Reach down inside the hopper and rock the fuel metering cup back and forth (being careful not to put fingers in fuel cavity of metering cup). The cup should move approximately 1/4" in either direction. If it does not move, something is jamming it (usually a foreign object) and will have to be removed by using one of the following methods:

- A. Using a tool, such as a slotted screw driver, clear the obstruction (between the fuel cavity of the metering cup and the blade).

- B. Locate the metering cup motor cooling propellor on the back of the appliance and turn it by hand in the reverse direction until the metering cup rotates back far enough to clear the obstruction.
- C. If procedures A or B fails to clear the obstruction, then remove the metering cup motor and metering cup to find and clear the obstruction.

Step #5 Confirm Cup and Auger Motor Operation

Set the main power switch to the "FEED SYSTEM" position. Press the "START" button. Both the cup and auger motor should start. If the motors run but the fuel metering cup and/or auger does not turn, check the cast iron coupler on the ends of each motor shaft to make certain the set screw is tight on the flat part of the shaft. If the motors are not running, use a volt meter to check for line voltage (115v) at the molex connector or check them by using the procedure described in Step #1, paragraph 2.

Note: Anytime you are checking the motors, you should verify the speed at which the motors are turning. This can be accomplished by timing the revolution of the coupler. Using the set screw as a reference point, the bottom motor (auger) will make approximately one revolution in 10 seconds. The top motor (cup) will make approximately one revolution every 48 seconds.

Step #6 Re-light The Stove

Follow the normal start up procedure. If the unit fails to start, check to be certain the leads to the safety disc are attached.

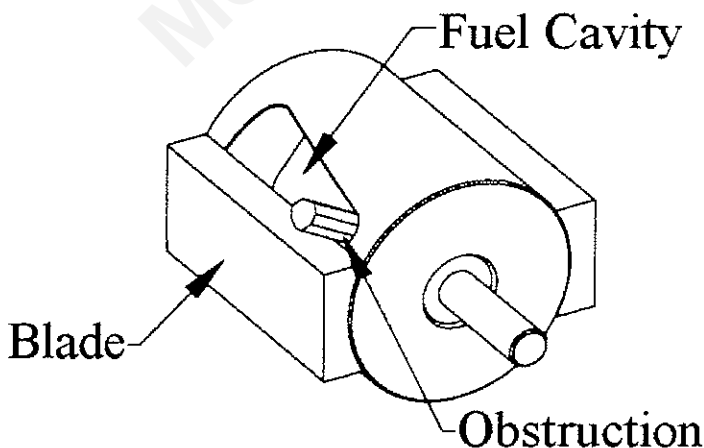

WIRING DIAGRAM

NaturalFire™ Pellet Stove Wiring Diagram

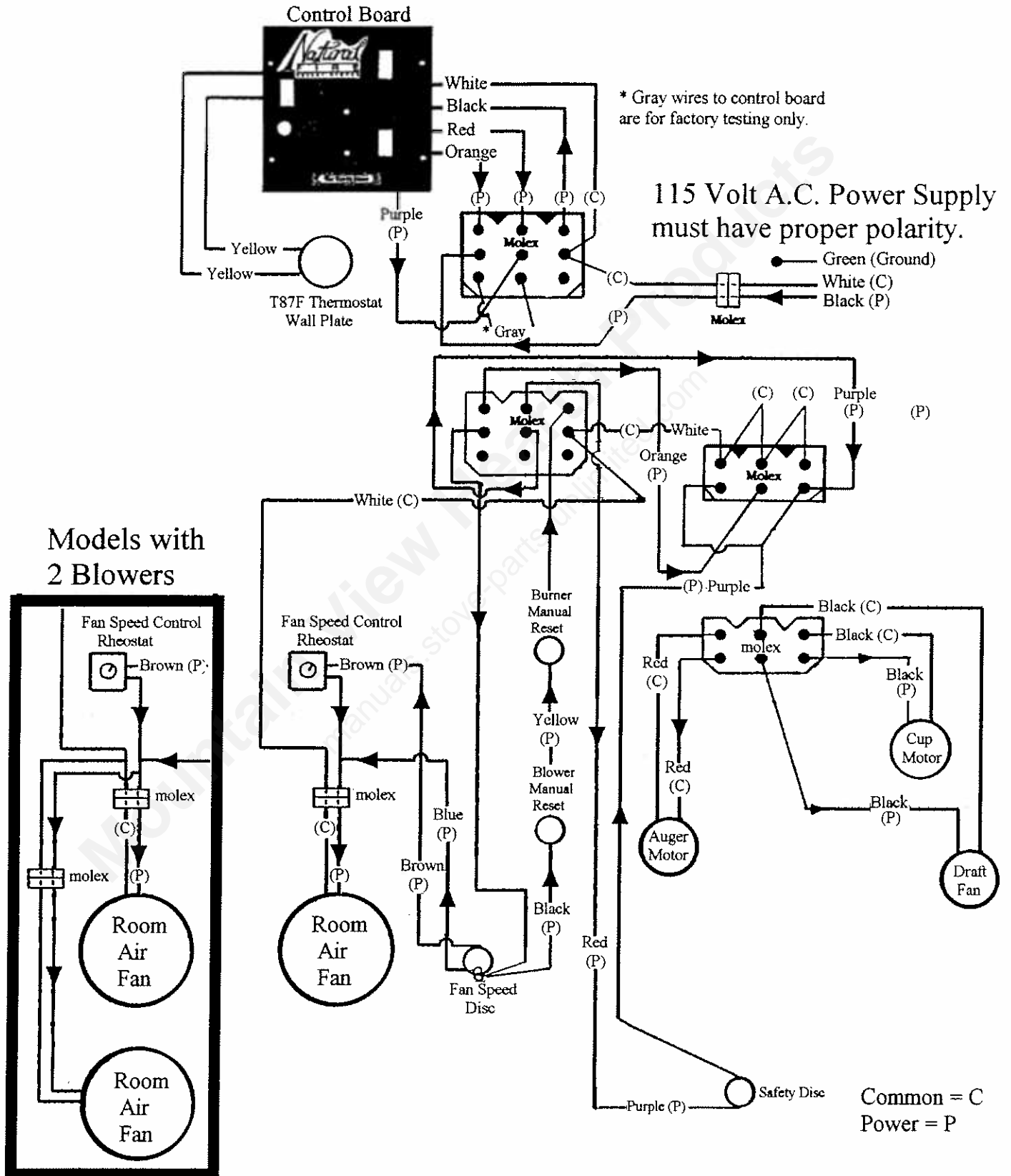

POWER FLOW DIAGRAM

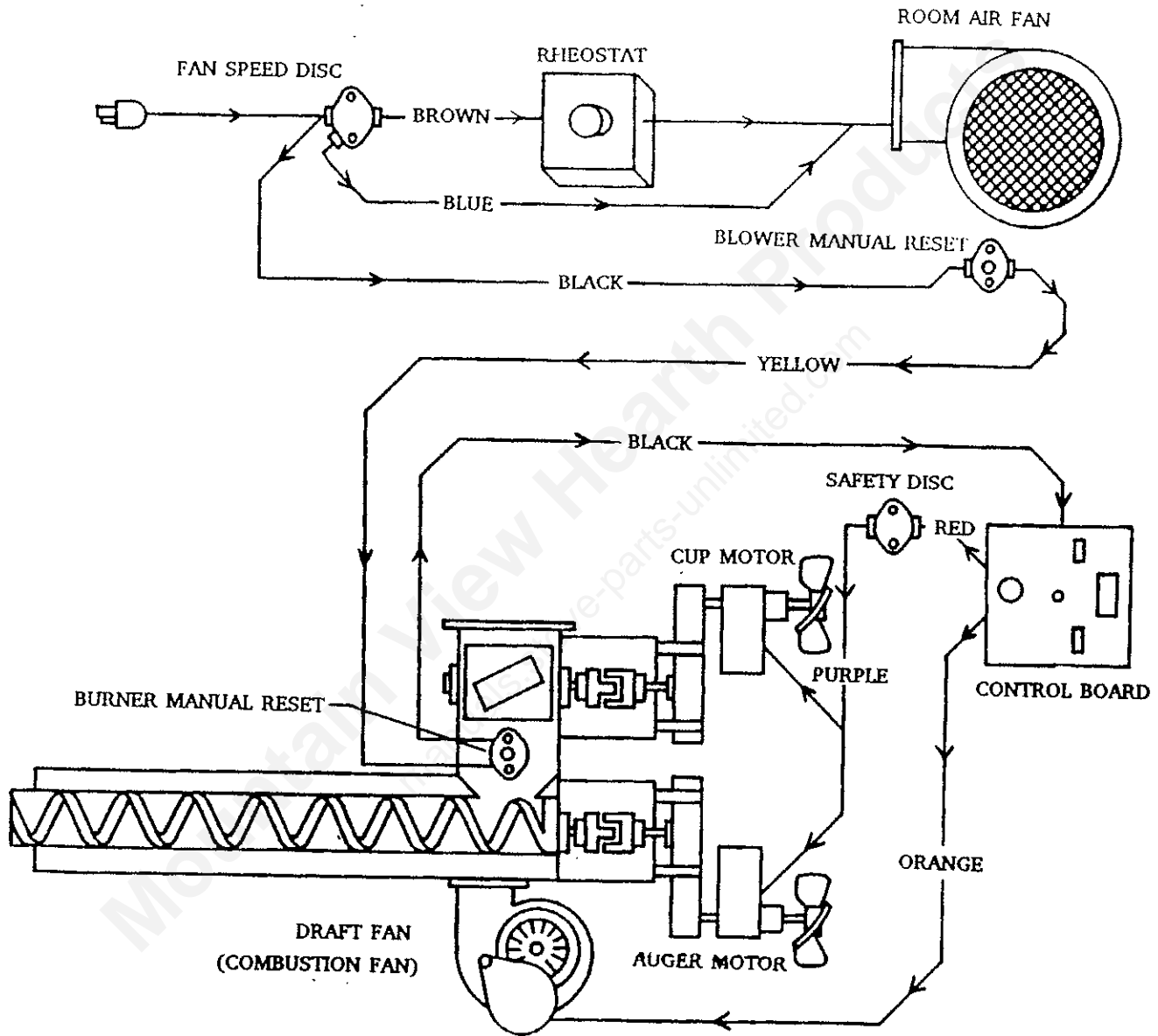

Glossary of Terms

AUGER The Auger transfers the fuel down the Burner Tube into the Firepot.

AUGER MOTOR The Auger Motor drives the Auger to deliver fuel to the Firepot.

BURNER TUBE The Burner Tube contains two passageways; one for the Auger and the other for combustion air. This tube supplies both the fuel and combustion air to the Firepot.

CUP MOTOR The Cup Motor drives the Fuel Metering Cup to deliver fuel to the Auger.

DRAFT FAN Pushes air into the Firepot for combustion and into the flue for draft.

FAN SPEED DISC At stove temperatures above 140°, the Fan Speed Disc activates by-passing the Rheostat causing the Room Air Fan(s) to run at full speed.

FIREPOT The Firepot is where combustion occurs.

FUEL METERING CUP The Fuel Metering Cup meters the amount of fuel and delivers it down to the Auger. The cup will deliver a set amount of fuel.

HOPPER The Hopper is where the pellets are stored and funneled down to feed the Fuel Metering Cup.

MAIN POWER SWITCH The Main Power Switch is the main switch allowing electricity to flow through the Primary Control Board to the components.

MANUAL RESET If the temperature of the stove reaches 200° F, the Manual Reset will "POP" and stop the flow of electricity to the fuel feed system.

MOTOR CABINET Covers the Fuel Feed and Burner System components.

SAFETY DISC At stove temperatures above 120°, the Safety Disc engages to allow electricity to flow to the fuel feed system.

RHEOSTAT At stove temperatures below 140° F, the Rheostat can be used to vary the speed of the Room Air Fan(s).

SPECIFICATIONS

TP340

Approx Sq Ft Heat Capacity	Up to 1500 Sq. Ft.
Flue size	4" Top or Rear
Width	27"
Depth Overall	34"
Height Overall	27 1/2"
Bk/Hopper Cntr of Flue	20"
Floor to Rear Flue Center	10"
Outside Air Provision	Yes
Floor Protection Requirements	
Mobile Home	Yes
Residential	No
Fuse	3 amp
Hopper Capacity	35 lbs
Heat Input (maximum)	40,000 BTU/hr
Ship Weight	400 Lbs.
Room Blower	160 CFM .9 amps
Cup Motor	Approx. 1 RPM .34 amps
Auger Motor	Approx. 6 RPM 1.12 amps
Draft Fan	Approx. 60 CFM .65 amps

~ Square feet heating capacities are approximations only. They will vary depending upon the level of insulation, climate, house design, ceiling height, ambient outside temperatures and how the stove is operated.

COMPONENT DIAGRAMS

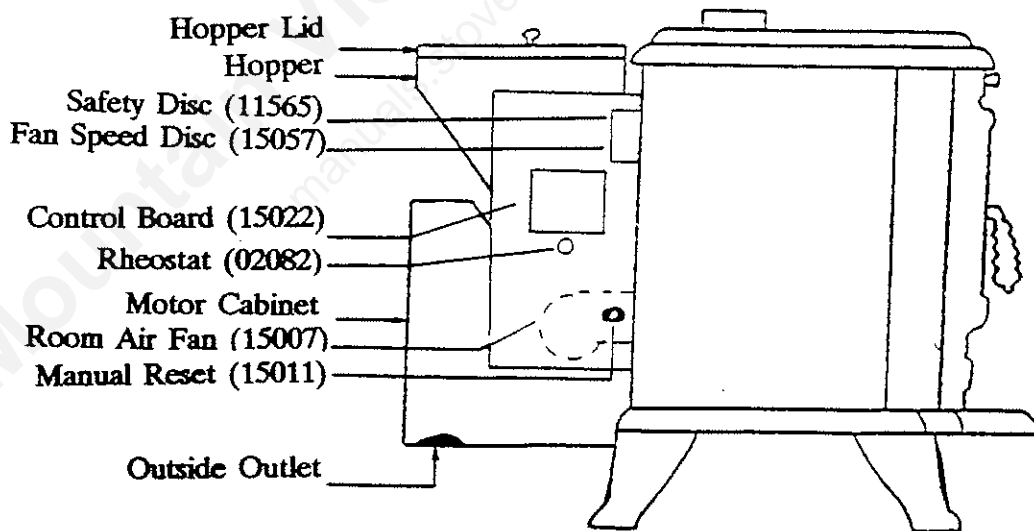
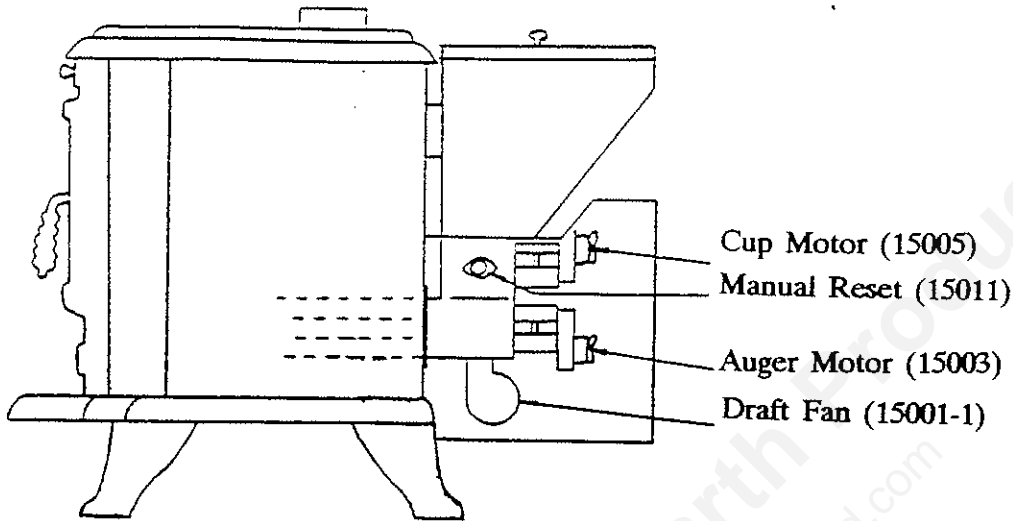

The Earth Stove®

NeutralFire™ Limited Warranty

WHO IS COVERED:

The original purchaser.

WHAT IS COVERED:

100% of all parts to be free of defects in materials and workmanship (except marble).

FOR HOW LONG:

One year from date of purchase.
Marble is covered for 90 days.

ADDITIONAL COVERAGE:

Electrical parts are covered 100% for two years from date of purchase.

The stove body, door frame, and exchange tubes are covered year two through five at the current retail price at time of repair or replacement, according to the schedule below:

- Year 2 - 80% coverage
- Year 3 - 60% coverage
- Year 4 - 40% coverage
- Year 5 - 20% coverage

Year two through five coverage excludes:

- Glass
- Gaskets/Rope
- Baffles
- Paint
- Logs
- Firepot

WHAT IS NOT COVERED:

- * The cost of inspection
- * Adjustments to the stove
- * Removal and reinstallation costs, shipping costs to and from factory and or authorized service center.
- * Shipping damage, improper handling, improper operation, misuse, abuse, neglect, accident, damage from improper installation, alteration, or unauthorized service.

ALL THE ABOVE MUST BE BORNE BY THE PURCHASER

WHAT YOU MUST DO TO OBTAIN WARRANTY SERVICE:

Contact your selling dealer. Provide the following information to the dealer; Model number, Serial number, Date of Purchase, and Place of Purchase (if different).

OR

Prior to repair or replacement, send the defective part (Freight Prepaid) with the above information to:

The Earth Stove, Inc.
10595 SW Manhasset
Tualatin, OR 97062

IMPORTANT: THIS WARRANTY IS NOT VALID UNLESS:

The warranty registration card has been properly completed and returned within 30 days of purchase.

The defective stove or part is promptly delivered, with ALL FREIGHT AND HANDLING CHARGES PREPAID, to The Earth Stove, Inc. or our authorized dealer from which the stove was purchased.

The appliance must be installed by a Qualified Technician.

We shall not be liable for incidental or consequential damages or commercial loss, nor for any loss or damage except as set forth in this warranty.

This warranty gives you specific legal rights and you may have other rights which vary from state to state. Some states may not allow the limitations or exclusions set forth so the limitations or exclusions may not apply to you. No person is authorized to extend or enlarge any liability or obligation which we may have in connection with the sale of the stove.

RETAIN THIS FOR YOUR RECORDS

Model _____

Serial Number _____

Dealer _____

Date of Purchase _____

Mountain View Hearth Products
manuals.stove-parts-unlimited.com