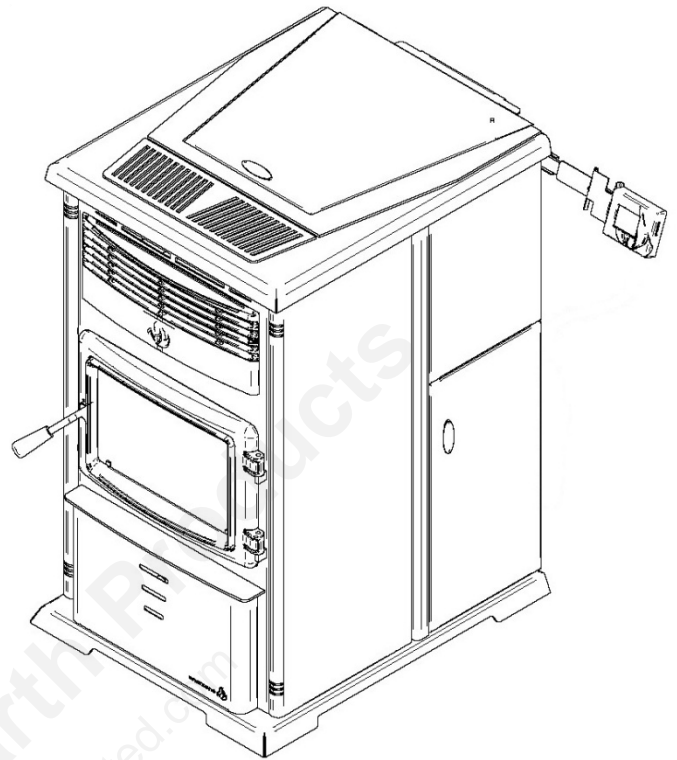


enerzone



More than just  
a heating solution

MODEL EUROMAX



## OWNER'S MANUAL

- **Warning:** If your appliance is not properly installed a house fire may result. For your safety, follow the installation directions. Contact local building or fire officials about restrictions and installation inspection requirements in your area. These authorities should be consulted to determine if there is a need to obtain a permit.
- **PLEASE** read this entire manual before installation and use of this pellet fuel-burning room heater. Failure to follow these instructions could result in property damage, body injury, or even death.
- Save these instructions.
- Some surfaces become hot at higher feeding rates. To prevent potential burns, avoid contact with those areas.
- This heating unit must serve as a supplementary heat source. An alternative heat source should be available in the home if needed. The manufacturer cannot be responsible for additional heating costs associated with the use of an alternative heat source.
- It is highly recommended that the user buys this product from a retailer who can provide installation and maintenance advices.

### PROFESSIONAL INSTALLATION IS HIGHLY RECOMMENDED



*This manual is available for free download on the manufacturer's web site. It is a copyrighted document. Re-sale is strictly prohibited. The manufacturer may update this manual from time to time and cannot be responsible for problems, injuries, or damages arising out of the use of information contained in any manual obtained from unauthorized sources.*

Printed in  
Canada

Manufactured by:  
Stove Builder International Inc.  
St-Augustin-de-Desmaures (Quebec)  
CANADA

45432A  
19-08-2013



## INTRODUCTION

Thank you for purchasing the EUROMAX pellet stove. You are now prepared to burn pellet in the most efficient, convenient way possible. To achieve the safest, most efficient and most enjoyable performance from your stove, you must do three things: **1) Install it properly; 2) Operate it correctly; and 3) Maintain it regularly.** The purpose of this manual is to help you do all three.

**PLEASE read this entire manual before installation and use of this pellet fuel-burning room heater. Failure to follow these instructions could result in property damage, bodily injury or even death.**

**Keep this manual handy for future reference.**

Your Enerzone EUROMAX has been independently tested to ASTM E1509-04 Standard Specification for Room Heaters, Pellet Fuel Burning Type, UL 1482-2010 and ULC-S627-00 Standard for Solid Fuel Room Heaters, Oregon Administrative Rules for Mobile Homes (814-23-900 through 814-23-909) and Installation as a Stove Heater.

This pellet stove, when installed, must be electrically grounded in accordance with local codes, or in the absence of local codes, with the *National Electrical Code, ANSI/NFPA 70 and CSA-C22.1.*

We recommend that our pellet hearth products be installed and serviced by professionals who are certified in the United States by NFI (National Fireplace Institute®) or in Canada by WETT (Wood Energy Technology Transfer) or in Quebec by APC (Association des Professionnels du Chauffage).

The bottom-feed burner system of this appliance is designed and tested specifically for use only with four different types of pellets: standard wood pellets, 100% bark pellets, sawdust/hay mix pellets, and switch grass pellets. This appliance is designed for residential installation according to current national and local building codes as a freestanding room heater. It is also approved as a mobile home heater. An outside combustion air source is mandatory.

The stove will not operate using natural draft or without a power source for the blower systems and fuel feed system and must not be burned with any type of coal.

This stove is designed to provide the optimum proportions of fuel and air to the fire in order to burn free of smoke and soot. Any blockage of the air supply to or from the stove will seriously degrade its performance and will be evidence by a smoking exhaust and a sooting window. For best operation, the ash content of the pellet fuel should be less than 1% and the calorific value approximately 8,200 BTU/LB. Others fuels with a high ash content will require a higher level of maintenance and cleaning.

Commercial and industrial installations of the Enerzone EUROMAX should not be used since operational control is often not well managed in these settings.

# SAFETY PRECAUTIONS



● DO NOT OPERATE YOUR STOVE IF YOU SMELL SMOKE COMING FROM IT. TURN IT OFF, MONITOR IT, AND CALL YOUR DEALER.



● NEVER USE GASOLINE, GASOLINE-TYPE LANTERN FUEL, KEROSENE, CHARCOAL LIGHTER FLUID, OR SIMILAR LIQUIDS TO START OR "FRESHEN UP" A FIRE IN THIS STOVE. KEEP ALL SUCH LIQUIDS WELL AWAY FROM THE STOVE WHILE IN USE.



● NEVER BLOCK FREE AIRFLOW THROUGH THE OPEN VENTS OF THE STOVE.



● NEVER TRY TO REPAIR OR REPLACE ANY PART OF THE STOVE UNLESS INSTRUCTIONS ARE GIVEN IN THIS MANUAL. ALL OTHER WORK SHOULD BE DONE BY A TRAINED TECHNICIAN.



● THE STOVE WILL NOT OPERATE DURING A POWER OUTAGE. IF AN OUTAGE DOES OCCUR, CHECK THE STOVE FOR SMOKE SPILLAGE AND OPEN A WINDOW IF ANY SMOKE SPILLS INTO THE ROOM.



● DISCONNECT THE POWER CORD BEFORE PERFORMING ANY MAINTENANCE OR REPAIRS ON THE STOVE.  
NOTE: TURNING THE STOVE "OFF" DOES NOT DISCONNECT ALL POWER FROM THE STOVE.



● DO NOT UNPLUG THE STOVE IF YOU SUSPECT A MALFUNCTION. TURN THE STOVE OFF, PERIODICALLY INSPECT IT, AND CALL YOUR DEALER.



● KEEP FOREIGN OBJECTS OUT OF THE HOPPER.



● DO NOT THROW THIS MANUAL AWAY. THIS MANUAL HAS IMPORTANT OPERATING AND MAINTENANCE INSTRUCTIONS THAT YOU WILL NEED AT A LATER TIME. ALWAYS FOLLOW THE INSTRUCTIONS IN THIS MANUAL.



● DO NOT PLACE CLOTHING, FURNITURES OR OTHER FLAMMABLE ITEMS ON OR NEAR THE STOVE.



● THE VIEWING DOOR MUST BE CLOSED AND LATCHED DURING OPERATION.



● DO NOT OPERATE THE STOVE IF THE FLAME BECOMES DARK AND SOOTY OR IF THE BURN POT OVERFILLS WITH PELLETS. TURN THE STOVE OFF, PERIODICALLY INSPECT IT, AND CALL YOUR DEALER.



● DO NOT TOUCH THE HOT SURFACES OF THE HEATER. CONTACT WITH THE UNIT MAY CAUSE SKIN BURNS. KEEP CHILDREN AWAY FROM THE UNIT AND EDUCATE THEM OF THE DANGERS OF A HIGH TEMPERATURE STOVE. YOUNG CHILDREN SHOULD ALWAYS BE SUPERVISED WHEN THEY ARE IN THE SAME ROOM AS THE STOVE.



● IF THE STOVE IS INSTALLED IN A ROOM WITHOUT AIR CONDITIONING, OR IN AN AREA WHERE THERE IS DIRECT SUNLIGHT ON THE UNIT, IT IS POSSIBLE THAT THIS CAN CAUSE THE TEMPERATURE OF THE STOVE TO RISE TO OPERATIONAL LEVELS. THIS CAN ACTIVATE ONE OF THE SENSORS WHICH MAY CAUSE THE STOVE TO START ON ITS OWN. IT IS RECOMMENDED THAT THE STOVE BE UNPLUGGED WHEN NOT IN USE FOR PROLONGED AMOUNTS OF TIME (I.E. DURING THE SUMMER MONTHS).



● CONTACT YOUR LOCAL BUILDING OFFICIALS TO OBTAIN A PERMIT AND INFORMATION ON ANY INSTALLATION RESTRICTIONS OR INSPECTION REQUIREMENTS IN YOUR AREA. NOTIFY YOUR INSURANCE COMPANY OF THIS STOVE AS WELL.



● THE EXHAUST SYSTEM MUST BE COMPLETELY AIRTIGHT AND PROPERLY INSTALLED. ALL VENT CONNECTOR JOINTS MUST BE SEALED AND FASTENED IN ACCORDANCE WITH THE PELLET PIPE MANUFACTURER'S INSTRUCTIONS TO ENSURE CONSISTENT PERFORMANCE AND AVOID SMOKE AND ASH SPILLAGE.



● THIS UNIT MUST BE PROPERLY INSTALLED TO PREVENT THE POSSIBILITY OF A HOUSE FIRE. THE INSTRUCTIONS MUST BE STRICTLY ADHERED TO. DO NOT USE MAKESHIFT METHODS OR COMPROMISE IN THE INSTALLATION.



● YOUR STOVE REQUIRES PERIODIC MAINTENANCE AND CLEANING. FAILURE TO MAINTAIN YOUR STOVE MAY LEAD TO SMOKE SPILLAGE IN YOUR HOME.



- ALLOW THE STOVE TO COOL BEFORE CARRYING OUT ANY MAINTENANCE OR CLEANING. ASHES MUST BE DISPOSED IN A METAL CONTAINER WITH A TIGHT LID AND PLACED ON A NON COMBUSTIBLE SURFACE WELL AWAY FROM THE HOME STRUCTURE.



- THIS APPLIANCE IS DESIGNED AND TESTED SPECIFICALLY FOR USE ONLY WITH FOUR DIFFERENT TYPES OF PELLETS: STANDARD WOOD PELLETS, 100% BARK PELLETS, SAWDUST/HAY MIX PELLETS, AND SWITCH GRASS PELLETS. ANY OTHER TYPE OF FUEL BURNED IN THIS HEATER WILL VOID THE WARRANTY AND SAFETY LISTING.



- THIS STOVE MUST BE CONNECTED TO A STANDARD 120 V., 60 HZ GROUNDED ELECTRICAL OUTLET. DO NOT USE AN ADAPTER PLUG OR SEVER THE GROUNDING PLUG. DO NOT ROUTE THE ELECTRICAL CORD UNDERNEATH, IN FRONT OF, OR OVER THE STOVE.



- THE STOVE MUST BE BOLTED TO THE FLOOR, HAVE OUTSIDE AIR, AND NOT BE INSTALLED IN A BEDROOM (PER H.U.D. REQUIREMENTS). CHECK WITH LOCAL BUILDING OFFICIALS.



- THE EXHAUST SYSTEM SHOULD BE CHECKED, AT A MINIMUM, AT LEAST TWICE A YEAR FOR ANY BUILD UP OF SOOT OR CREOSOTE.



- THE INFORMATION GIVEN ON THE CERTIFICATION LABEL AFFIXED TO THE APPLIANCE ALWAYS OVERRIDES THE INFORMATION PUBLISHED, IN ANY OTHER MEDIA (OWNER'S MANUAL, CATALOGUES, FLYERS, MAGAZINES AND/OR WEB SITES).



- IT IS MANDATORY TO CONNECT THIS STOVE TO A 4" FRESH AIR INLET TO AVOID THE RISK OF HOPPER BURN BACK CAUSED BY NEGATIVE PRESSURE.



- STOVE BUILDER INTERNATIONAL INC. GRANTS NO WARRANTY, IMPLIED OR STATED, FOR THE INSTALLATION OR MAINTENANCE OF YOUR STOVE, AND ASSUMES NO RESPONSIBILITY OF ANY CONSEQUENTIAL DAMAGE(S).

## REGISTER YOUR WARRANTY ONLINE

To receive full warranty coverage, you will need to show evidence of the date you purchased your stove. Keep your sales invoice. We also recommend that you register your warranty online at:

[www.enerzone-intl.com/warranty-registration.aspx](http://www.enerzone-intl.com/warranty-registration.aspx)

Registering your warranty online will help us track rapidly the information we need on your stove.



# TABLE OF CONTENTS

<b>SAFETY PRECAUTIONS</b> .....	<b>3</b>
<b>1. INSTALLATION</b> .....	<b>7</b>
1.1. <b>FEATURES</b> .....	<b>7</b>
1.2. <b>PREPARATION</b> .....	<b>7</b>
1.3. <b>CLEARANCES</b> .....	<b>7</b>
1.4. <b>COMBUSTION AIR SUPPLY</b> .....	<b>9</b>
1.5. <b>ANCHOR THE STOVE</b> .....	<b>10</b>
1.6. <b>VENTING</b> .....	<b>11</b>
1.6.1. <b>Equivalent Vent Length (EVL)</b> .....	<b>11</b>
1.6.2. <b>Installation Configurations</b> .....	<b>12</b>
a) Vertically with new chimney system.....	13
b) Horizontally through wall.....	14
c) Vertically into existing chimney system .....	16
d) Vertically into existing masonry fireplace .....	16
e) Installation through side of masonry chimney .....	17
<b>2. OPERATION</b> .....	<b>18</b>
2.1. <b>PROPER FUEL</b> .....	<b>18</b>
2.2. <b>WHERE TO STORE BAGS OF PELLETS</b> .....	<b>18</b>
2.3. <b>UNIT CONTROLS</b> .....	<b>18</b>
2.3.1 <b>LCD User Interface – Operation and Configuration</b> .....	<b>19</b>
2.4. <b>OPERATION TREE</b> .....	<b>21</b>
2.5. <b>SELECTING LANGUAGE</b> .....	<b>21</b>
2.6. <b>VIEW STATISTICS</b> .....	<b>21</b>
2.7. <b>CHANGING °F TO °C</b> .....	<b>21</b>
2.8. <b>CHOOSING THE HEAT SETTING</b> .....	<b>21</b>
2.9. <b>CHOOSING THE PILOT LAG TIME</b> .....	<b>22</b>
2.10. <b>CHOOSING THE CONVECTION BLOWER SPEED</b> .....	<b>22</b>
2.11. <b>CHOOSING MANUAL OR THERMOSTATIC MODE</b> .....	<b>22</b>
2.12. <b>OPERATING THE STOVE USING A THERMOSTAT</b> .....	<b>22</b>
2.12.1. <b>Thermostat Installation</b> .....	<b>22</b>
2.13. <b>PRE-START-UP CHECK</b> .....	<b>23</b>
2.14. <b>FILLING-UP THE AUGER</b> .....	<b>24</b>
2.15. <b>IF YOUR STOVE RUNS OUT OF PELLETS</b> .....	<b>24</b>
2.16. <b>REFUELING</b> .....	<b>24</b>
2.17. <b>STARTING THE STOVE</b> .....	<b>25</b>
2.18. <b>BUILDING A FIRE</b> .....	<b>25</b>
2.19. <b>EARLY SIGNS OF AN OVERFIRED STOVE</b> .....	<b>25</b>
2.20. <b>SHUT DOWN PROCEDURE</b> .....	<b>25</b>
2.21. <b>OPERATING SAFETY PRECAUTIONS</b> .....	<b>25</b>
<b>3. MAINTENANCE</b> .....	<b>27</b>
3.1. <b>CLEANING THE BURN POT AND THE AIR WASH INLET</b> .....	<b>27</b>
3.2. <b>MAINTENANCE OF THE COMBUSTION CHAMBER, HEAT EXCHANGERS AND BLOWER HOUSING</b> .....	<b>28</b>
3.3. <b>MAINTENANCE OF THE HEAT EXCHANGERS AND BLOWER HOUSING</b> .....	<b>28</b>
3.4. <b>VENTING SYSTEM MAINTENANCE</b> .....	<b>29</b>
3.4.1. <b>Dealing with a Chimney Fire</b> .....	<b>29</b>
3.4.2. <b>Soot and Flyash – Formation and need for removal</b> .....	<b>30</b>
3.5. <b>ASH REMOVAL</b> .....	<b>30</b>
3.5.1. <b>Ash Disposal and Ash Vacuum Use</b> .....	<b>30</b>
3.6. <b>DOOR ADJUSTMENT</b> .....	<b>31</b>
3.7. <b>DOOR GASKET MAINTENANCE</b> .....	<b>31</b>
3.8. <b>GLASS CARE</b> .....	<b>32</b>
3.9. <b>REMOVAL AND REPLACEMENT OF BROKEN DOOR GLASS</b> .....	<b>32</b>



3.10.	REMOVAL AND REPLACEMENT OF GASKETS .....	35
3.11.	RECOMMENDED MAINTENANCE SCHEDULE .....	40
4.	TROUBLESHOOTING GUIDE .....	41
5.	ELECTRICAL DIAGRAM .....	47
5.1	FUSE ACCESS:.....	48
6.	REPLACEMENT PARTS .....	49
APPENDIX A	.....	52
APPENDIX B	.....	53
APPENDIX C	.....	54
ENERZONE LIMITED LIFETIME WARRANTY	.....	56

Mountain View Hearth Products  
manuals.stove-parts-unlimited.com



# 1. INSTALLATION

## 1.1. FEATURES

### ENERZONE EUROMAX FREESTANDING PELLET STOVE

- Width: 24"
- Height: 41"
- Depth: 28"
- Weight: 375 lbs.
- Flue size: 4"
- Hopper Capacity: Up to 125 lbs. *(This can vary depending on pellet size, length, and diameter)*
- EPA status: < 4.5 g/h
- Burn rate: 1.3 lbs to 8.5 lbs. per hour
- BTU range: 10,500 to 70,000
- Electrical consumption:
  - 5 Amps lighting cycle
  - 2.5 Amps. continuous duty
- Control board fuses: Main: 7.5A-250V fastblow
  - Convection blower: 5A-250V fastblow
  - Combustion blower: 3A-250V fastblow
  - Exhaust blower: 3A-250V fastblow
  - Auger 1: 3A-250V fastblow
  - Auger 2: 3A-250V fastblow
  - Ignitor : 5A-250V fastblow
- Electrical requirement: 120VAC 15A
- Approved installations: mobile home or conventional

## 1.2. PREPARATION

Factory packaging must be removed, and some minor assembly work is required prior to installation:

- The handle and door must be adjusted;
- The stove must be leveled using threaded legs;
- The door overlay must be installed on the door frame

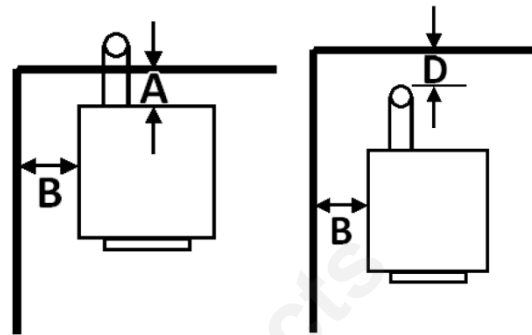
The LCD control must be installed on the back (left or right) of the stove; (see appendix C )

## 1.3. CLEARANCES

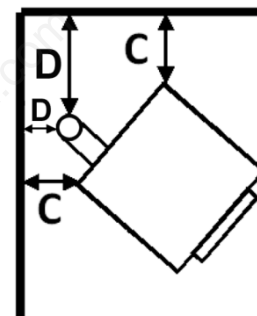
The Enerzone EUROMAX has been tested and listed for installation in residential and mobile home

**FLOOR PROTECTION:** minimum to 6" in the front and 6" on each side of the door opening. The stove must be placed on a continuous (grouted joints) noncombustible material such as ceramic tile, cement board, brick, 3/8" millboard or equivalent, or other approved or listed material suited for floor protection.

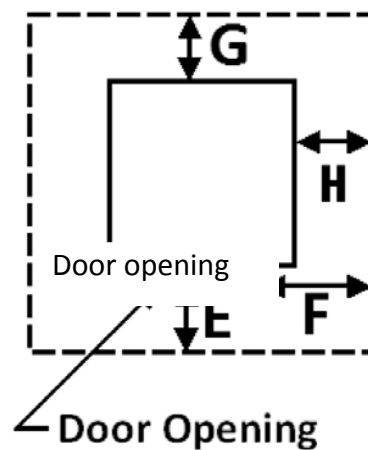
**NOTE:** ceramic tile, or any tile, requires a continuous sheet beneath to prevent the possibility of embers



**FIGURE 1**  
**Back wall installation**



**FIGURE 2**  
**Corner installation**



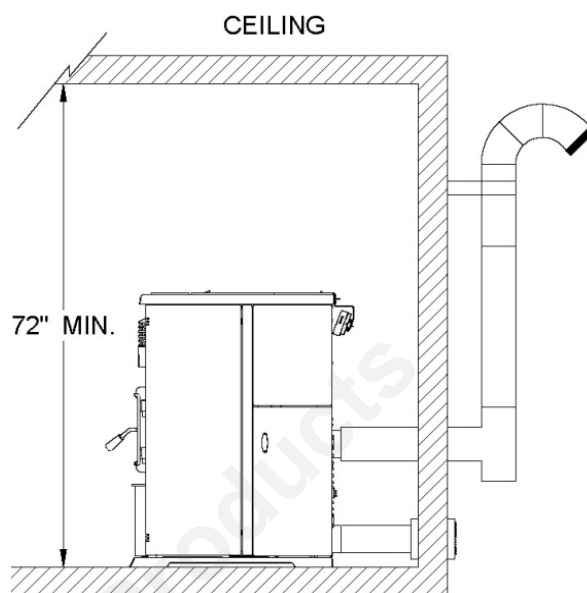
**FIGURE 3**  
**Floor protection**

falling through to the combustible floor if cracks or separation should occur in the finished surface, this would include floor protection for built-in raised hearths. Check local codes for approved alternatives.

Clearances are measured from the sides, back, or face (door opening). For ceiling clearance refer to figure 4.

**Clearances may only be reduced by means approved by the regulatory authority.**

**NOTE:** In order to allow the LCD support to move freely and fully extend, you should allow a minimum of 4" clearance in a back installation (Figure 1) or 6 ¼" from the corners in a corner installation (Figure 2). However, if you wish to install the appliance with minimum clearances it is possible to install the LCD control box elsewhere but within the maximum length of the Telco wire provided.



**FIGURE 4**  
**Ceiling clearance**

**CAUTION: DO NOT USE MAKESHIFT MATERIALS OR COMPROMISES IN THE INSTALLATION OF THIS UNIT.**

**CAUTION: INSTALL VENT WITH CLEARANCES SPECIFIED BY THE VENT MANUFACTURER.**

This heating unit must serve as a supplementary heat source. An alternative heat source should be available in the home if needed. The manufacturer cannot be responsible for additional heating costs associated with the use of an alternative heat source.

It is highly recommended that the user buys this product from a retailer who can provide installation and maintenance advices.

**We recommend leaving 24" on each sides of the appliance in order to facilitate access for maintenance.**

	CLEARANCES TO COMBUSTIBLES	
	CANADA	USA
<b>A</b>	2" (55 mm)	2" (55 mm)
<b>B</b>	6" (155 mm)	6" (155 mm)
<b>C</b>	2" (55 mm)	2" (55 mm)
<b>D</b>	3" (80 mm)	3" (80 mm)

	FLOOR PROTECTION	
	CANADA	USA
<b>E</b>	18" (460 mm)	6" (155 mm)
<b>F</b>	N/A (USA only)	6" (155 mm)
<b>G</b>	8" (205 mm)	N/A (Canada only)
<b>H</b>	8" (205 mm)	N/A (Canada only)



## 1.4. COMBUSTION AIR SUPPLY

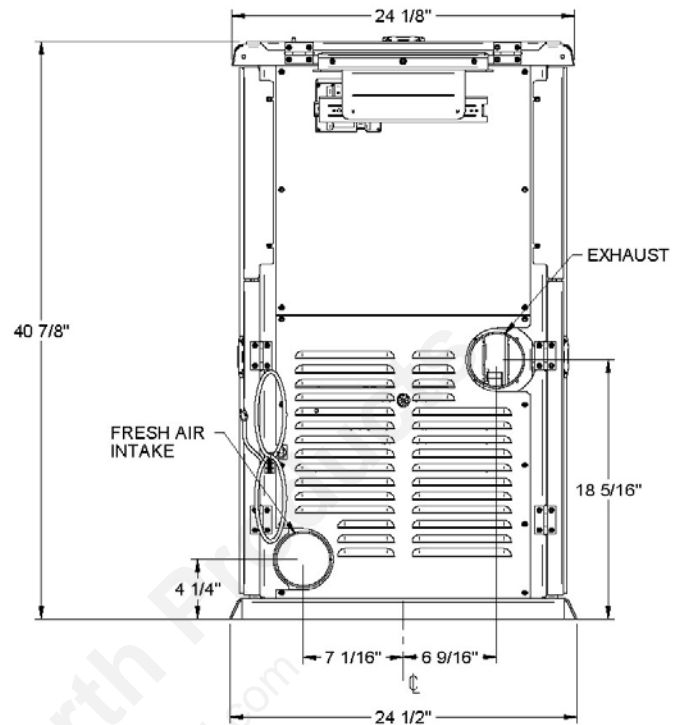
It is mandatory to connect this stove to an outside combustion air source to reduce the risk of hopper burn back caused by negative pressure. An insulated 4" inside diameter metallic pipe, either flexible or rigid, must be attached to the inlet at the stove's rear (refer to figure 5). A rodent guard (minimum 1/4" wire mesh) must be used at the terminus (refer to figure 7). All connections must be secured and airtight by either using the appropriately sized hose clamp and/or UL-181-AP foil tape. Also make sure that the fresh air damper is open while the stove is running. The fresh air intake damper is located at the back of the stove right hand side (refer to figure 6.).

### For mobile home installations only:

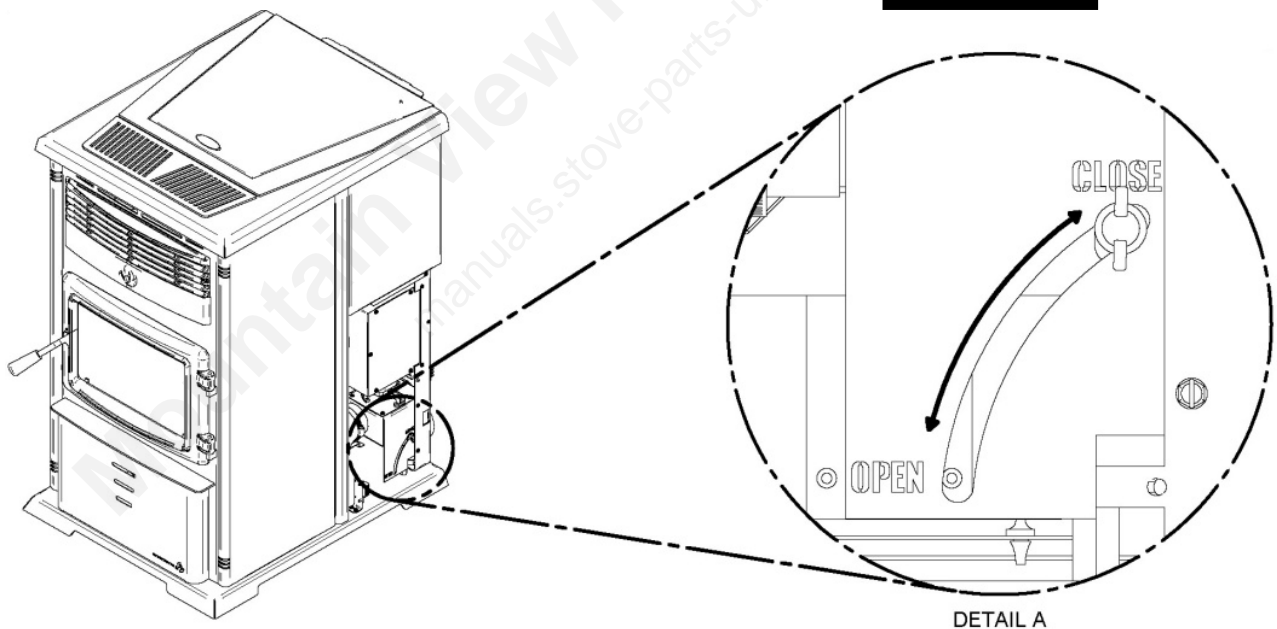
- No combustion air supply may exceed 10 feet.

### Sources of Outside Combustion Air:

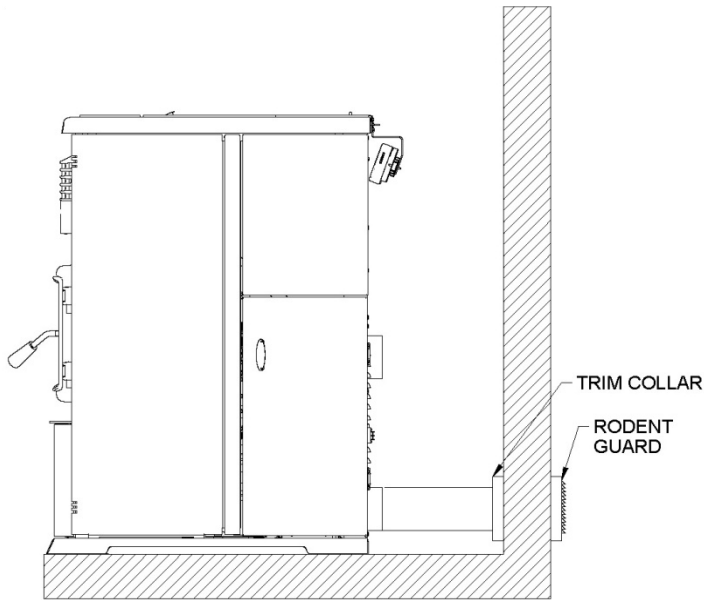
- A hole in floor near stove rear terminating only in a ventilated crawl space.
- A hole in the wall behind the stove.



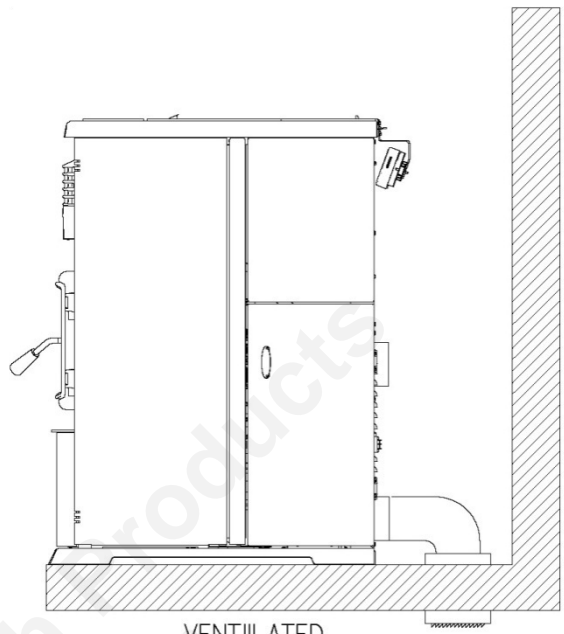
**FIGURE 5**  
**Rear view**



**FIGURE 6.**  
**The fresh air intake damper**



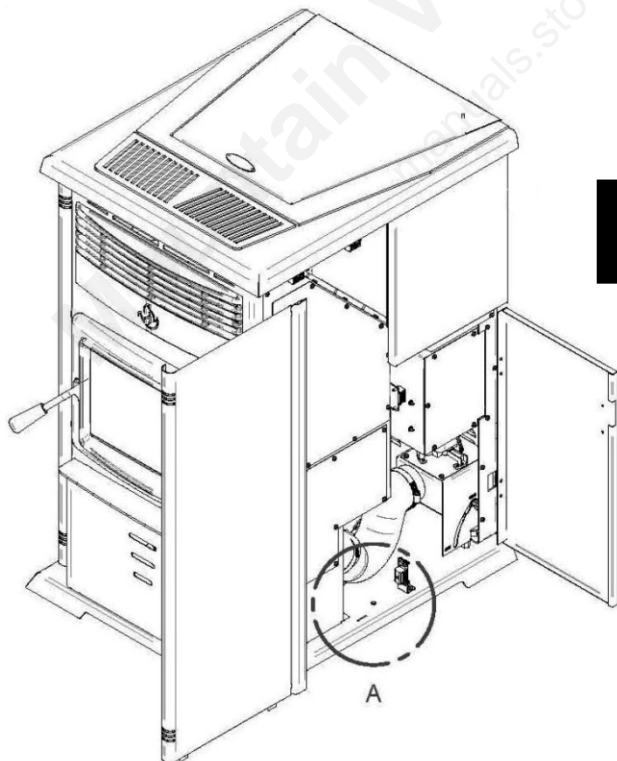
**FIGURE 7**  
**Fresh air supply**



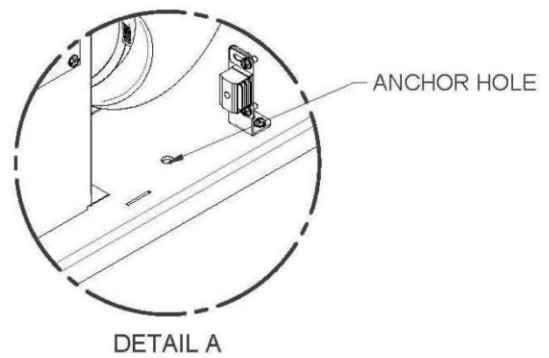
VENTILATED  
CRAWL SPACE  
**FIGURE 8**  
**Fresh air supply**

### 1.5. ANCHOR THE STOVE

The stove must be anchored to the floor with screws. Please use the two holes located on each side of the pedestal (see figure 9.)



**FIGURE 9**  
**Anchor location**



## 1.6. VENTING

In Canada, we recommend that you use a listed pellet vent that meets the ULC S-609-M89/ORD C441-M90 Standard.

For the United States, we recommend that you use a listed pellet vent that meets the UL-641 Standard.

This unit can be vented in an existing factory-built or masonry chimney with the addition of a liner, provided the chimney is more than 4" in diameter. The liner should be listed and should meet the ULC S-635/640 standard in Canada and the UL-1777 standard in the USA. Refer to the instructions provided by the vent or chimney manufacturer, especially when passing through a wall, ceiling, or roof.

**Your venting system should have at least one foot of vertical rise for each foot of horizontal run. The total vertical rise should never be less than 3 feet (see Appendix A).**

This unit uses a pressurized exhaust system. All vent connector joints must be sealed and fastened. If vented horizontally, joints should be made gastight. Please consult the pellet pipe manufacturer's instruction to ensure proper installation and consistent performance to avoid smoke and ash spillage.

**DO NOT CONNECT THIS UNIT TO A CHIMNEY FLUE SERVING ANOTHER APPLIANCE.**

**DO NOT INSTALL A FLUE DAMPER IN THE EXHAUST VENTING SYSTEM OF THIS UNIT.**

**WARNING: INSTALL VENT AT CLEARANCES SPECIFIED BY THE VENT MANUFACTURER.**

**WARNING: DO NOT INSTALL IN SLEEPING ROOM**

**CAUTION: THE STRUCTURAL INTEGRITY OF THE MANUFACTURED HOME FLOOR, WALL, AND CEILING/ROOF MUST BE MAINTAINED**

**CAUTION: THE CHIMNEY CONNECTOR SHALL NOT PASS THROUGH AN ATTIC OR ROOF SPACE, CLOSET OR SIMILAR CONCEALED SPACES, OR FLOORS, OR CEILINGS.**

### 1.6.1. Equivalent Vent Length (EVL)

The longer the run of pipe in your installation, the greater the restriction in your system.

- Always use 4" pipe
- Horizontal runs shall not exceed 9 feet.
- Never exceed 30 feet of EVL..

To calculate EVL, use the following conversions table:

Qty	Type of pipe	EVL equivalent(ft)
1	90° elbow or "T"	5
1	45° elbow	3
1 ft	Horizontal pipe run	1
1 ft	Vertical pipe run	0.5

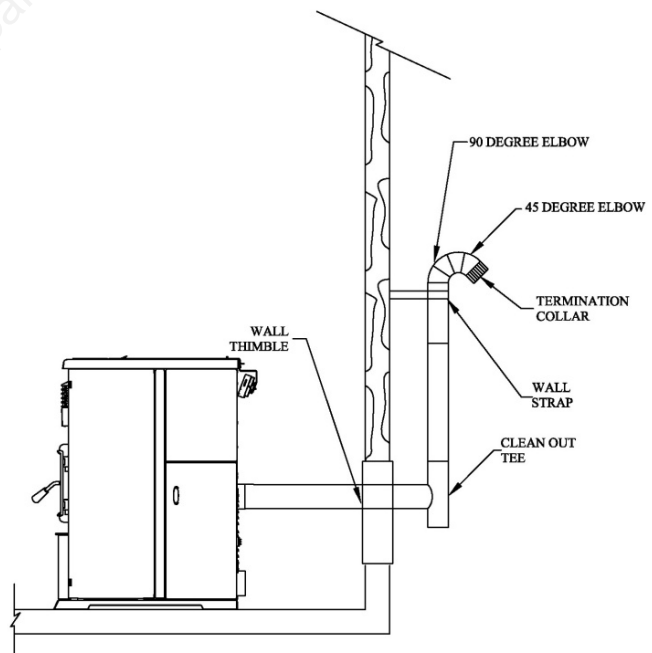
Here is an example on how to calculate the EVL of your installation. (See Figure 10):

$$(3 \times 4' \text{ of vertical length} = 12' \times 0.5 = 6 \text{ EVL}) +$$

$$(1 \times \text{elbow or "T"} = 5 \text{ EVL}) +$$

$$(2 \times 1' \text{ of horizontal length} = 2 \text{ EVL})$$

$$\text{Total EVL} = (6 + 5 + 2) = 13.$$



**FIGURE 10**  
**Venting through wall**

## 1.6.2. Installation Configurations

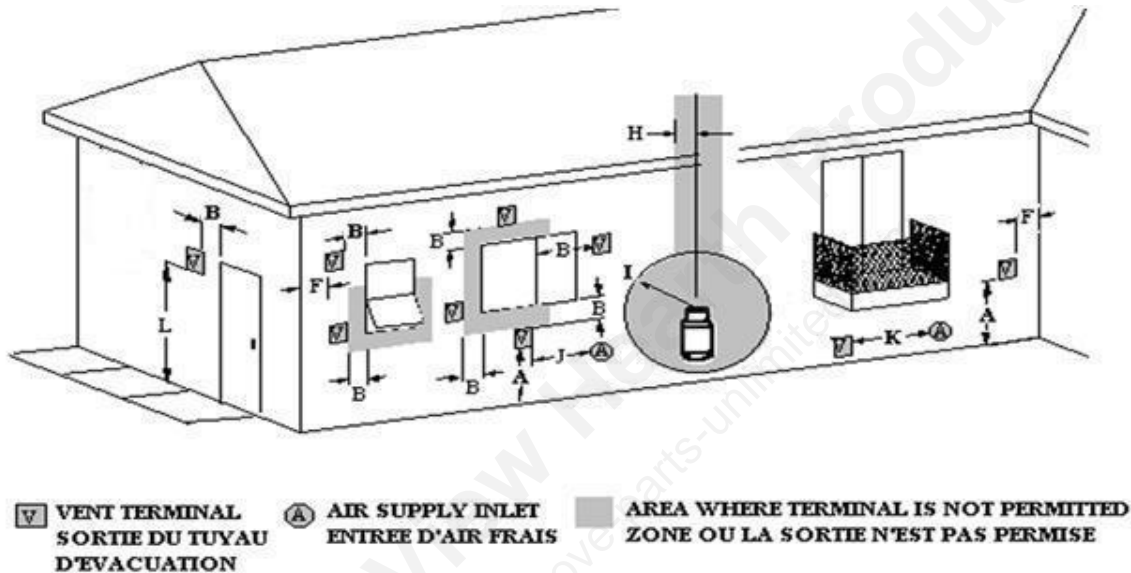
### Termination Location

Termination should not be located so that hot exhaust gases can be a hazard. They can reach temperatures of 500 °F and cause serious burns.

**CAUTION: TERMINATION COLLAR (SPARK ARRESTER) IS MANDATORY.**

Refer to NFPA 211 (USA) or CSA B365 (Canada) for rules for the distance of exit terminal from windows and openings. The exit terminal of a mechanical draft system, other than a direct vent appliance shall be located in accordance with the following.

### Permitted Termination Location



### Canada:

Letter	Min. clearances	Description
A	12" (30 cm)	Clearances above adjacent grade level.
B	39" (100 cm)	Clearance to window or door that may be opened
F	0" (0 cm)	Clearance to outside corner
H	39" (100 cm)	Not to be installed above a meter/regulator assembly within 39" (100 cm) horizontally from the vertical center-line of the regulator and for 15' vertically
I	72" (183 cm)	Clearance to gas service regulator vent outlet or within 39" (100 cm) of an oil tank vent or an oil tank fill inlet
J	39" (100 cm)	Clearance to the combustion air inlet to any other appliance
K	72" (183 cm)	Clearance to a mechanical air supply inlet
L	84" (213 cm)	Clearance above paved side-walk or a paved driveway located on public property
	39" (100 cm)	Clearance to property boundary
		A vent shall not terminate underneath a veranda, porch, or deck

**United States:**

- Not Less than 36" (91 cm) above any forced air inlet located within 10 feet (305 cm);
- Not Less than 48" (122 cm) below et horizontally from, or one foot (30 cm) above, any door, window or gravity air inlet into any building;
- Not Less than 24" (61 cm) from an adjacent building and not less than 84" (213 cm) above grade when located adjacent to a public walkway.
- Cannot be located less than 12 inches (300mm) above grade.
- Cannot be located above a gas meter/regulator within 3 feet (900mm) horizontally of the vertical center line of the regulator.
- Not within 6 feet (1.8 meters) of a gas service regulator vent outlet.
- Other restrictions may apply. See NFPA 211 for further information.

**a) Vertically with new chimney system**

(Refer to Figure 13)

**NOTE:** Follow vent chimney manufacturer's instructions.

**OPTION:** To achieve a centered vertical installation, a 45° elbow and a clean-out tee can be used to offset the pipe from the exhaust outlet to the rear center of the stove.

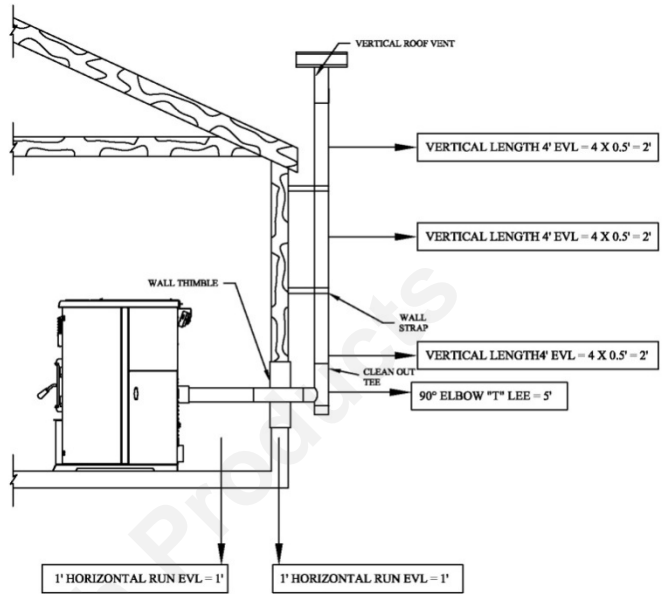
**OPTION:** Install vent elbow in place of clean-out tee. Locate stove. Drop plumb bob to center of tee outlet, mark point on ceiling. Install ceiling support and vent pipe per vent manufacturer's instructions.

1. Always maintain 3" clearance from combustible materials. When passing through additional floors or ceilings, always install firestop spacer.
2. After lining up for hole in roof, cut either a round or square hole in roof, always 3" larger all the way around pipe. Install upper edge and sides of flashing under roofing materials, nail to the roof along upper edge. Do not nail lower edge. Seal nail heads with flexible waterproof sealant.
3. Apply flexible, waterproof sealant where the storm collar meets the vent. Slide storm collar down until it sits on the flashing. Seal and install cap. Mobile home installations must use a spark arrester.

**b) Horizontally through wall**  
(Refer to figures 11 or 12)

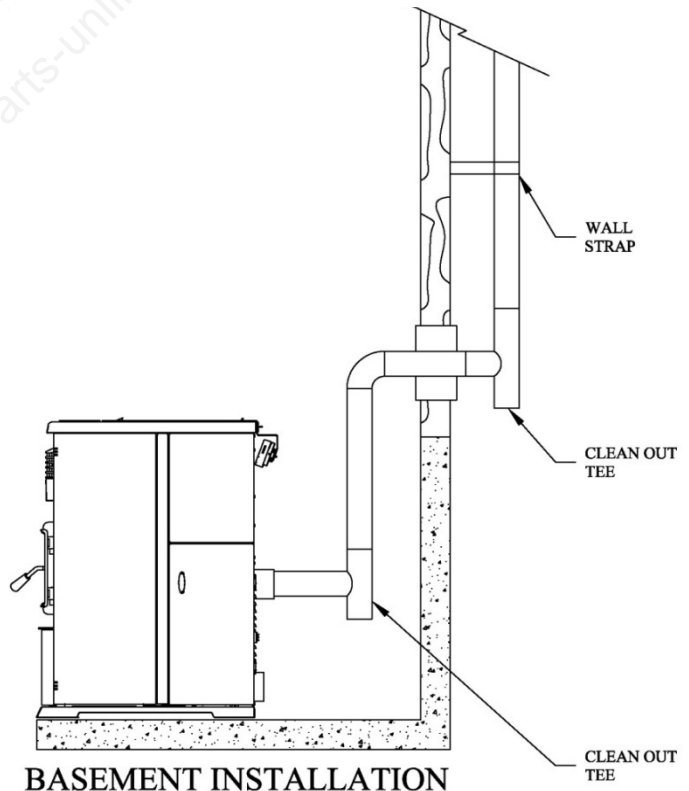
**NOTE:** Follow Vent chimney manufacturer's instructions.

1. Position stove, adhering to clearances shown in Figures 1, 2, 3 & 4.
2. Locate position of hole in wall; directly behind stove exhaust vent (refer to figure 5).
3. Always maintain 3" clearance from combustible materials.
4. Install vent wall thimble per vent manufacturer's instructions.

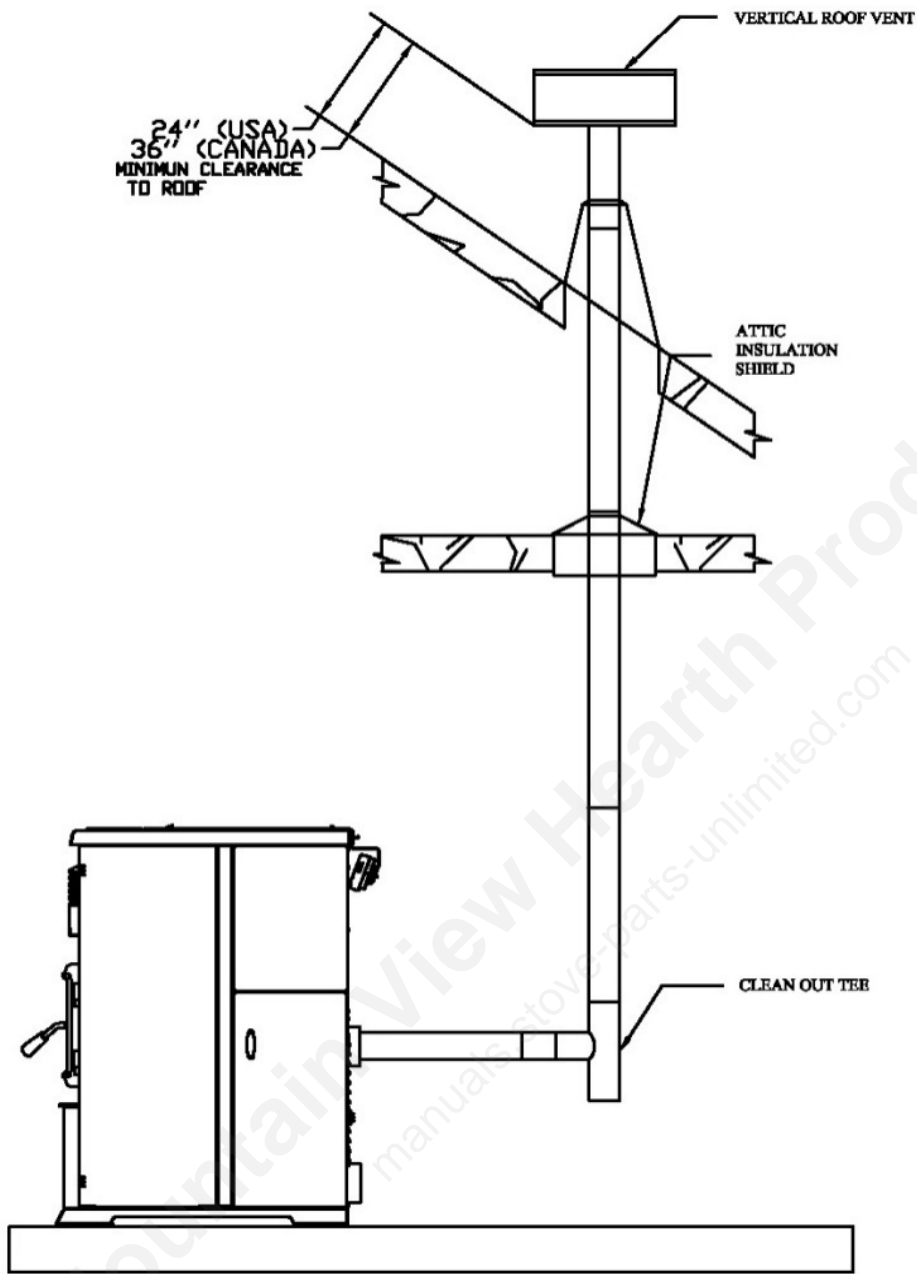


**FIGURE 11**  
**Venting through wall**

5. Attach enough piping to penetrate and extend at least 6 inches beyond the exterior wall. There should always be at least one foot of vertical rise for each foot of horizontal run (see Appendix A). At least 3 feet of vertical rise are needed in all cases. A longer vertical rise will favour a better exhaust.
6. To reduce the risk of smoke spillage, never terminate with a horizontal run. If your system terminates with a horizontal run, add at least 3 feet of vertical rise (see Appendix A).
7. Attach cap and seal outside wall thimbles with non-hardening waterproof mastic.



**FIGURE 12**  
**Venting through wall**  
**Basement installation**

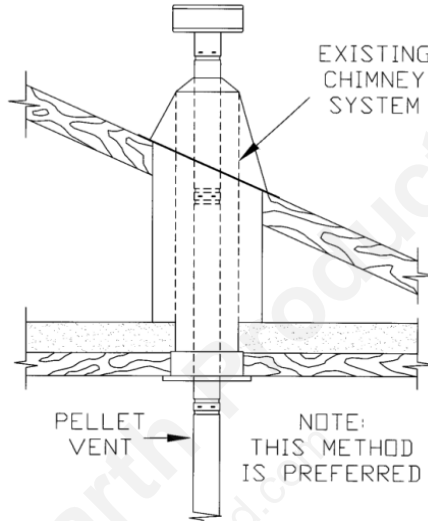


**FIGURE 13**  
Venting through roof

c) **Vertically into existing chimney system**  
 (Refer to Figure 14)

As an alternative, 4" vent can be run inside existing chimney to termination (Figure 14). This is the preferred method.

Follow guidelines for equivalent vent length.

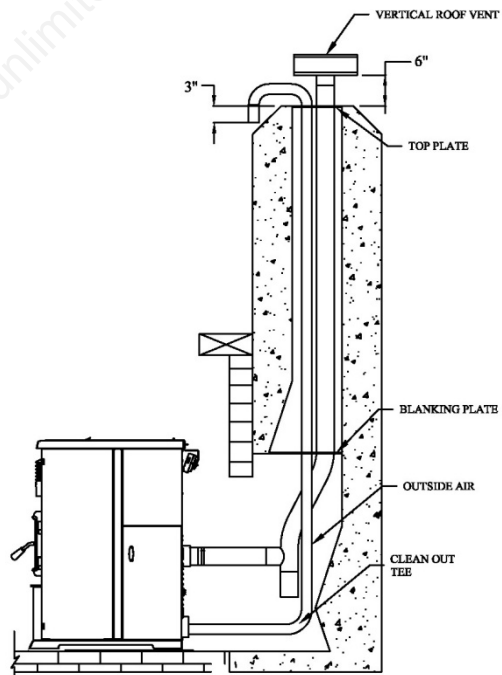


**FIGURE 14**  
**Venting through existing chimney**

d) **Vertically into existing masonry fireplace**  
 (Refer to figure 15)

**NOTE:** Follow vent chimney manufacturer's instructions.

1. Have the masonry chimney inspected by a qualified chimney sweep or installer to determine its structural condition.
2. You will need a pipe length equal to the chimney height from the hearth. If outside combustion air is to be used, you will need a pipe length equal to the chimney height plus 18 inches.
3. Install a blanking plate and the chimney pipe, and if used the outside air pipe, as shown in Figure 15.
4. Attach the adapter, a section of pipe and clean out tee, making sure the clean out tee is centered in the chimney flue area. Use RTV, metallic tape, and a minimum of three self-taping screws at all joint connections to ensure a tight seal.
5. Position the stove, adhering to the clearances in Figures 1, 2, 3 & 4.
6. Measure and build chimney top plate. Cut out holes for chimney pipe, and if used the outside air pipe. Install and seal with non-hardening mastic to prevent water leakage. Install vent cap.



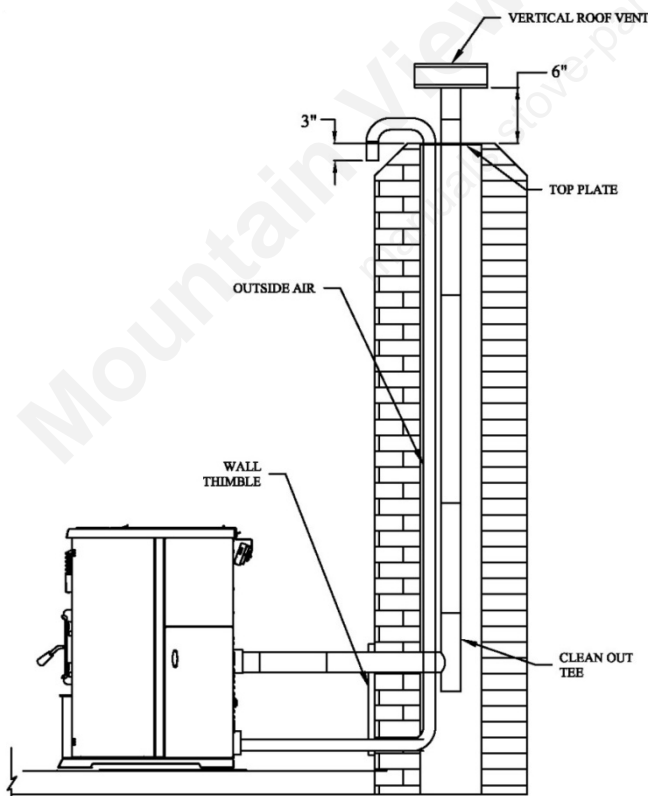
**Figure 15**  
**Venting through masonry chimney**

**e) Installation through side of masonry chimney**  
(Refer to figure 16)

**NOTE:** Follow vent chimney manufacturer's instructions.

1. Position the stove, adhering to the clearances in Figures 1, 2, 3 & 4. Mark the center of the hole where the pipe is to pierce the masonry chimney.
2. It will be necessary to break out the masonry around the location of the pipe center mark. Use a 5-inch diameter hole for 4-inch pipe.
3. Measure and build chimney top plate. Cut out holes for chimney and the outside air pipe.
4. Install the tee on the bottom of the vertical pipe system and lower it down the chimney until the center branch of the tee is level with the center of the hole in the masonry, as shown in Figure 16.
5. Install and seal the top plate from step 3 with non-hardening mastic. Slip the storm collar over the pipe, and while holding the pipe at the proper elevation, affix the collar with a minimum of three 1/4" stainless steel sheet metal screws. Seal all joints and seams around the collar.
6. Connect the horizontal pipe by pushing it through the hole in the masonry and lining it up with the branch in the tee. Push the pipe into the tee while twisting it to lock it into the tee.
7. If desired, once the horizontal pipe is in place, the space between the pipe and masonry may be filled with high-temperature grout.

Install the trim collar. An adjustable pipe length and adapter may be needed to finish the connection to the stove.



**Figure 16**  
**Venting through side of**  
**masonry chimney**

## 2. OPERATION

### 2.1. PROPER FUEL

**THIS STOVE IS APPROVED FOR BURNING four different types of pellets: standard wood pellets, 100% bark pellets, sawdust/hay mix pellets, and switch grass pellets! Each type of pellet has its properties and will burn differently.**

The ash produced can also vary greatly. Factory-approved pellets are those ¼" or 5/16" in diameter and not over 1" long. Longer or thicker pellets sometimes bridge the auger flights, which prevents proper pellet feed. **Burning other types of pellets is not permitted. It will violate the building codes for which the stove has been approved and will void all warranties.** The different types of pellets that have been tested in the Enerzone EUROMAX were made of the following types of biomass:

#### Wood pellets

Wood pellets, whether made of hard or soft wood, are easy to burn. The pellets used are the same type as the ones used in most pellet stoves. They should produce a fairly small quantity of ash.

#### Wood and hay pellets

Pellets made of wood and hay will produce more ash than straight wood pellets. The wood and hay pellets that have been tested in your EUROMAX consisted of 1/3 hay and 2/3 wood. Make sure that any wood and hay pellets you put in your EUROMAX respect that mix (+/- 10%).

#### Bark pellets

100% bark pellets produce a hard crust that will be pushed into the ash drawer. Their ash content is very high. If you burn 100% bark pellets, make sure that the crust forming in front of the burn pot breaks and falls into the ash drawer. Ignition may be a bit more difficult and it is possible that the stove needs a second ignition cycle to properly light the bark pellets.

#### Switchgrass pellets

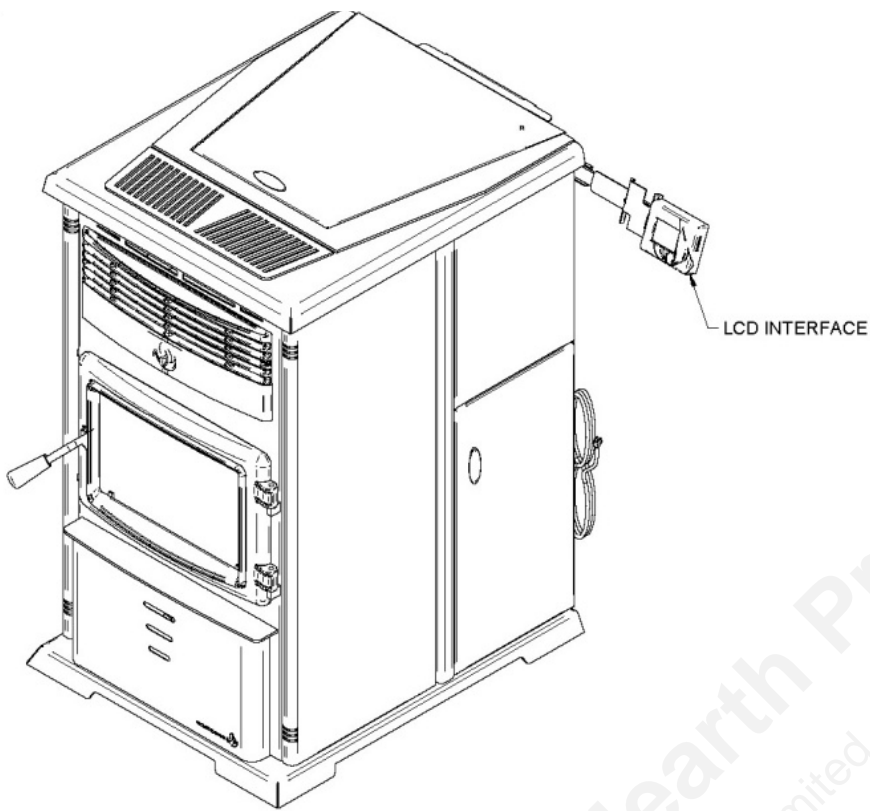
The ash content of switch grass pellets may vary depending on when this type of biomass is harvested. Switch grass will burn very clean. A crust will form in front of the burn pot. It should break easily and fall into the ash drawer. The crust is light and friable. It will occupy quite a bit of volume into the ash drawer. For this reason, if you are not present to empty the ash drawer, you should only fill 50% of the hopper.

### 2.2. WHERE TO STORE BAGS OF PELLETS

We recommend that you store your bags of pellets in a dry and well ventilated area if possible. Using dry pellets will increase the performance of your stove. You may want to have a bag or two in the same room as your stove for refuelling but make sure to respect the minimum clearances for combustible materials.

### 2.3. UNIT CONTROLS

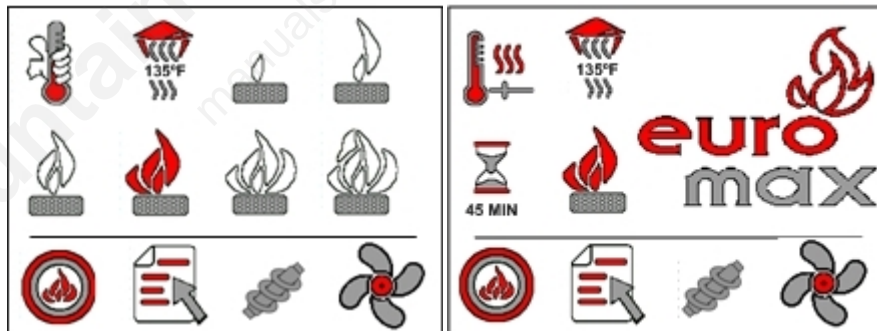
The Enerzone Euromax use a LCD screen, the latest technology in control devices. This LCD interface is located at the back on the right-hand side of the EUROMAX (see figure 17). The blowers and automatic fuel supply are controlled from this panel. The control panel functions are as follows.



**Figure 17**  
LCD Interface location

### 2.3.1 LCD User Interface – Operation and Configuration

The LCD interface used on the Enerzone Euromax is a touch screen, an electronic visual display that can detect the presence and location of a touch within the display area. Depends if you use the manual or the thermostatic mode you will visualize the following information (see figures 18 and 19):



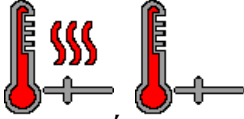
**Figure 18**  
Manual mode main page

**Figure 19**  
Thermostat mode main page

Here is a brief description of each bottom:



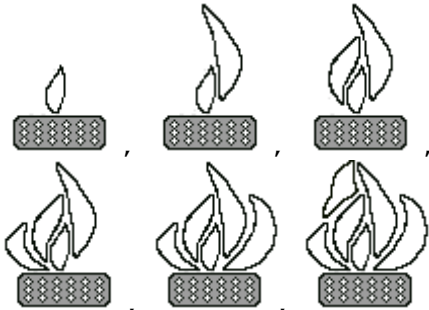
= Indicates that the stove status is on manual mode



= Indicates that the stove status is on thermostat mode. The red waves indicate that the thermostat is on demand. The waves will disappear once the desired temperature is reached.



= Indicates the flue temperature



= Indicates the heat setting. Starting from the smallest flame to the biggest flame, the respective levels are 1 to 6. Pressing on the desired heat level (flame) will change the color of the flame to red to show its activation.



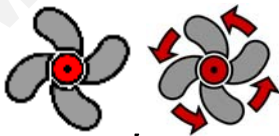
= Indicates whether the stove is on or off. If the flame is shown in the middle of the circle, the stove is on. If the flame is not shown in the middle of the circle, the stove is off.



= This button leads to the menu screen



This button is used to fill the auger. When the auger is running the auger button is going to show a red arrow.



= This button indicates if the convection blower speed control is on or off. If the fan is not surrounded by arrows, the speed control is off. If the fan is surrounded by arrows, the speed control is on.

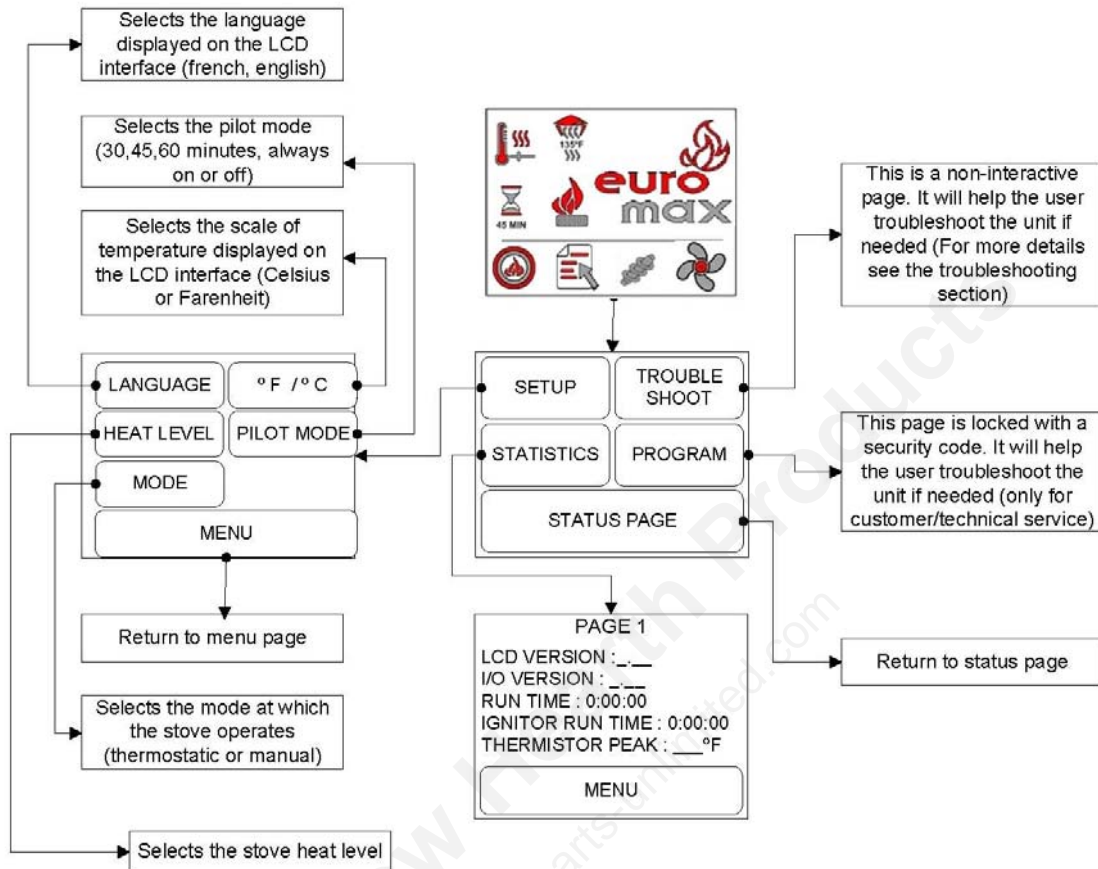


= The hourglass indicates how long the pilot will be on before shutting down the unit. The setting chosen by the user appears under the hourglass.



= This button is displayed when you have a warning message from your unit. Just press the button to read the message.

## 2.4. OPERATION TREE



**Figure 20**  
**Operation Tree**

## 2.5. SELECTING LANGUAGE

You can choose between English and French. In order to change the language, refer to the operation tree at the beginning of this section.

## 2.6. VIEW STATISTICS

Numerous statistics can be viewed, such as the stove run time (i.e. the number of hours the stove has operated since it was first used). In order to view statistics, refer to the operation tree at the beginning of this section.

## 2.7. CHANGING °F TO °C

You can choose between °F and °C. In order to change from °F to °C and vice-versa, refer to the operation tree at the beginning of this section.

## 2.8. CHOOSING THE HEAT SETTING

Your Euromax has an input starting at 10,500 BTU which can reach up to 70,000 BTU. There are six heat levels to choose from. In order to change the heat level, pressing on the desired heat level. The flame icon will change the color of the flame to red to show its activation.

## 2.9. CHOOSING THE PILOT LAG TIME

It is possible to change the setting of your unit such that if the thermostat does not call for heat after 45 minutes, the unit will remain at the lowest heat setting (#1) without shutting down (this is the PILOT ON mode). The stove will remain at the lowest heat level until the thermostat calls for heat again. It is also possible that the unit shuts down as soon as the thermostat stops calling for heat. This mode is called "PILOT OFF". Also you can set the lag time to 30, 45 or 60 minutes. If you prefer that your unit runs following one of these logics, you need to change the setting to PILOT ON or PILOT OFF. In order to change the pilot lag time, refer to the operation tree at the beginning of this section.

## 2.10. CHOOSING THE CONVECTION BLOWER SPEED

When you press the convection blower speed button, a screen appears with a cursor to adjust the fan speed as desired;

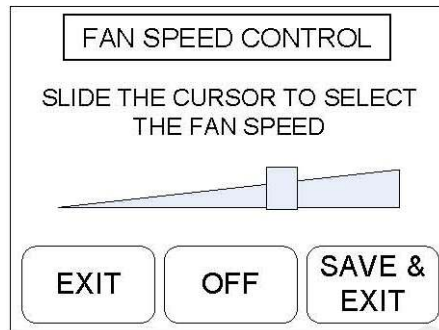


Figure 21  
Fan Speed Control

## 2.11. CHOOSING MANUAL OR THERMOSTATIC MODE

In the manual mode, your stove will run continuously at the feed rate selected until the stove runs out of pellets.

When set in thermostatic mode, the stove will automatically run at the heat level selected until the set room temperature is reached. When that occurs, the stove will switch to heat setting #1 (lowest), which is the pilot mode, until the thermostat calls for heat again. When the thermostat calls for heat again, the stove will increase its feed rate to match the heat setting selected, refer to the operation tree at the beginning of this section.

## 2.12. OPERATING THE STOVE USING A THERMOSTAT

A thermostat may help you maintain a constant house temperature automatically. A low voltage thermostat is required. A fixed wall mount or hand held model can be used. The control panel can be set up three ways to operate your stove in thermostatic mode.

### 2.12.1. Thermostat Installation

- Unplug the stove from the power outlet.
- Connect two thermostat wires to the terminal block located on the lower right side of the back of the stove. To do so, loosen the two screws and insert the wires in the terminals. Tighten the two screws. (See figure 22)

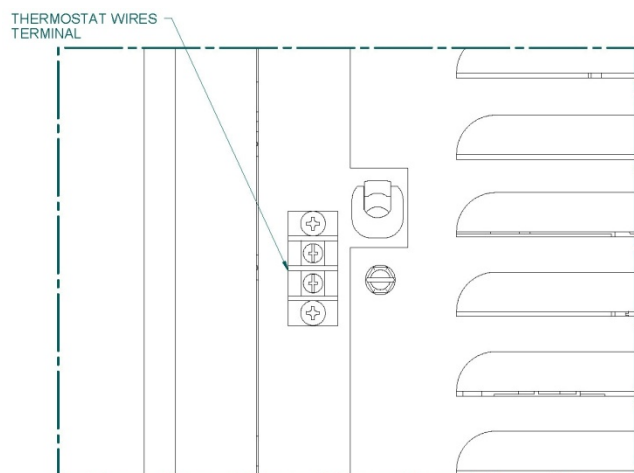
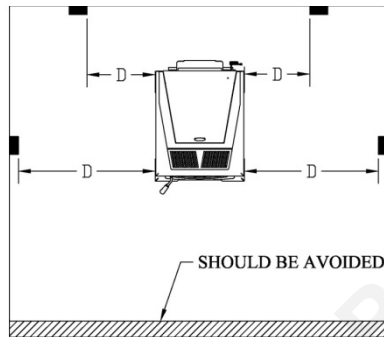


FIGURE 22  
Rear view

- If you are using a wireless wall thermostat or a hand held thermostatic remote control, you can locate the receiver behind the stove's back panel, on the right end side, just below the terminal block. Most receivers are already equipped with quick-connect terminals. Simply unplug the PC board wires connected to the back of the terminal block and connect them directly with the receiver's terminals. Location of the thermostat is very important to obtain the best comfort and efficiency from your EUROMAX. The thermostat should be mounted 50 inches from the floor on a wall located 15 to 20 feet from the stove. You should avoid an installation directly in front of the stove to avoid cycling.(See figure 23)



D = MINIMUM DISTANCE 15 FEET

**Figure 23**  
**Thermostat Location**

**N.B.:** It is possible to change the setting of your unit such that if the thermostat does not call for heat after 45 minutes(lag time), the unit will remain at the lowest heat level (#1) but will not shut down (this is the PILOT ON mode). The stove will remain at the lowest heat level until the thermostat calls for heat again. In the other way, it is also possible that the unit shuts down as soon as the thermostat stops calling for heat. This mode is called "PILOT OFF". If you prefer that your unit runs following one of these logics PILOT ON or PILOT OFF, you need to change the setting to ALWAYS ON or PILOT OFF. According to your preferences, you can also be able to set the pilot lag time to 30, 45 or 60 minutes. In order to change the pilot lag time, refer to the operation tree at the beginning of this section.

**NOTE:** When in thermostatic mode:

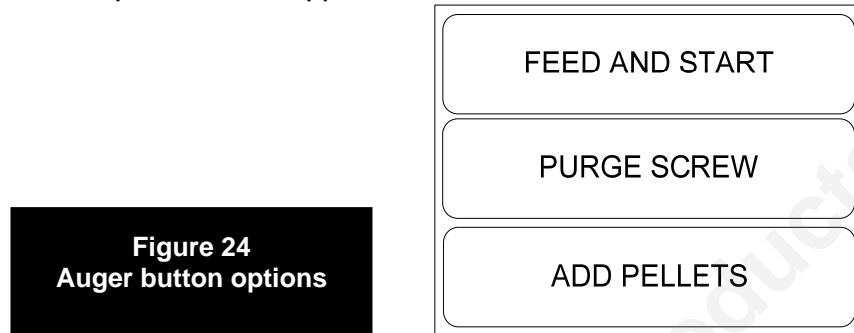
- You should not operate the manual control or play with the temperature setting.
- YOUR THERMOSTAT SHOULD BE INSTALLED BY AN AUTHORIZED DEALER OR SERVICE PERSON.

### 2.13. PRE-START-UP CHECK

Remove burn pot, making sure it is clean and none of the air holes are plugged. Clean the firebox, and then reinstall burn pot. Clean door glass if necessary (a dry cloth or paper towel is usually sufficient). Never use abrasive cleaners on the glass or door. Check fuel in the hopper, and refill if necessary. **Make sure that the fresh air inlet damper is open.**

## 2.14. FILLING-UP THE AUGER

When the stove runs out of pellets, it empties the auger housing. In order to start the stove again, you need to fill the auger to bring pellets to the burn pot for ignition. This process takes approximately 1 minute and a function has been programmed on the LCD interface. In order to fill the auger, push the auger button. When that button is pressed, a 3 option window appears:




The FEED AND START button is used when you start the stove after the hopper run out of pellet. The auger will run during 1 minute then the stove will start automatically an ignition sequence.

The PURGE SCREW button is used to empty the auger at the end of the season, the auger will run during 4 minutes.

The ADD PELLETS button is used to add more pellet in the burn pot, the auger will run for 20 seconds.

## 2.15. IF YOUR STOVE RUNS OUT OF PELLETS

If your stove runs out of pellets, the fire goes out and the auger motor and blowers will run until the stove cools down. This will take a few minutes. After the stove's components stop running, a warning message "NO FUEL" will appear on the LCD display.

To restart the stove, press the "RESET" button, refill the hopper, and press the  button followed by FEED AND START button.

## 2.16. REFUELING

We recommend that you not let the hopper go completely empty. Upon reloading, if the hopper lid stays open for more than 3 minutes, a warning code "HOPPER LID OPEN" will appear on the LCD display. To restart, press the "RESET" button, and then press the round "ON/OFF" icon on the main status page to start the unit.

**KEEP HOPPER LID CLOSED AT ALL TIMES EXCEPT WHEN REFILLING. THE HOPPER MAY BE FILLED WHILE THE STOVE IS OPERATING. DO NOT OVERFILL HOPPER.**

## 2.17. STARTING THE STOVE

Before you start your stove, fill hopper and clean burn pot. Once the hopper is full of pellets, the auger is filled, and the firebox door is closed, you can start the stove. In order to start the stove, select the desired mode (manual or thermostatic) then simply press the round "on/off" icon on the main status page.

If fire doesn't start in 35 minutes, a warning code

**FAILED IGNITION**

will appear. Refer to troubleshooting section for more details.

## 2.18. BUILDING A FIRE

Never use a grate or other means of supporting the fuel. Use only the Enerzone Euromax approved burn pot.

**NOTE:** During the first few fires, your stove will emit an odor and a small amount of fumes as the high temperature paint cures or becomes seasoned to the metal. Maintaining smaller fires will minimize this. Avoid placing items on stovetop during this period because paint could be affected. Make sure the room is well-ventilated. Open windows. Odors and fumes released during this process are unpleasant but they are not toxic.

## 2.19. EARLY SIGNS OF AN OVERFIRED STOVE

If you see a lazy, very high orange flame inside the firebox, it may be a sign that your stove is overfired and getting too hot. Under normal conditions, the flame should be about 12 inches high and it should be lively. It should have a bright, yellow color. Too much restriction in the venting system and a blocked heat exchanger are the primary causes of an overfired stove. If the stove becomes too hot, it will activate the thermistor located on the exhaust box beside the exhaust blower. If this occurs, a "UNIT OVERHEAT" code will appear on the LCD display. If you obtain a "UNIT OVERHEAT" code, it is a sign that your stove is getting dangerously hot. You need to clean the heat exchanger and verify the venting system. If you get a "UNIT OVERHEAT" code again, call your dealer.

## 2.20. SHUT DOWN PROCEDURE

Turning your stove off is a matter of pressing the round "ON/OFF" icon on the main status page. The little flame at the center of the icon will disappear when the stove is turned off. The blowers will continue to operate while the stove is cooling down.

## 2.21. OPERATING SAFETY PRECAUTIONS

### **PLEASE READ THIS!**

- a. **If you notice a smoldering fire** (burnpot full but no visible flame) **AND a heavy smoke buildup in firebox, immediately TURN OFF the stove, but DO NOT unplug it. Do not open the door. Make sure that the fresh air damper is open and do not tamper with any controls on the stove.** Wait until smoke inside the firebox clears and blowers shut down. Do as instructed in "PRE-START-UP CHECK" and "LIGHTNING PROCEDURE", then attempt to restart the fire. If the problem persists, contact your dealer. Please note that smoke build-up during ignition may occur. Smoke can accumulate in the firebox for a few seconds just before the igniter is hot enough to fire-up the pellets in the burn pot. This is normal. As soon as there is fire in the burn pot, smoke will disappear.
- b. **DO NOT STORE OR USE FLAMMABLE LIQUIDS, ESPECIALLY GASOLINE, IN THE VICINITY OF YOUR ENERZONE STOVE. NEVER USE A GAS OR PROPANE TORCH, GASOLINE, GASOLINE-TYPE LANTERN FUEL, KEROSENE, CHARCOAL LIGHTER FLUID OR SIMILAR FLUIDS TO START OR "FRESHEN UP" A FIRE IN THIS HEATER.**

- c. **WARNING: DO NOT OVERFIRE THIS STOVE.** This may cause serious damage to your stove and void your warranty. It also may create a fire hazard in your home. **IF ANY EXTERNAL PART OF THE UNIT BEGINS TO GLOW, YOU ARE OVERFIRING.** Immediately press the "MODE" switch on the control panel, until reaching the 'OFF' position. **DO NOT UNPLUG YOUR STOVE.** If you leave your house and your stove is not connected to a thermostat or a fresh air supply, do not leave it at the maximum setting. **If the ambient air in a confined room becomes too hot, the stove may overheat and the thermal protection on the combustion motor, exhaust motor or auger motor may be activated. This will cause one of the motors to stop and a warning code may appear. Also, the thermistor may reach its maximum limit. If this happens, the stove will automatically reduce the feeding rate until the thermistor temperature has decreased.**
- d. **KEEP ALL LOOSE OR MOVEABLE HOUSEHOLD COMBUSTIBLES, SUCH AS FURNITURE, DRAPES, TOYS, ETC. AT LEAST THREE FEET FROM THE OPERATING STOVE.**
- e. Maintain proper ventilation. It is important that adequate oxygen be supplied to the fire for proper combustion. During the winter season, make sure that the fresh air intake is free of any ice as this will starve the fire of air and prevent the proper operation of the stove. **YOUR STOVE MUST BE CONNECTED TO A 4" FRESH AIR KIT.** Always make sure that the fresh air intake damper is fully open when the stove is in use.
- f. The stove exhaust fan produces a negative pressure in the room. It draws air from the inside to the outside. In the same way, other appliances can also create a bigger negative pressure. In this case, as the air naturally flows from high pressure point to low pressure point, the bigger negative pressure may draw the smoke from the inside of the stove into the room. The stove can also affect other ventilation appliances, causing the same effect to them.
- g. Not following the instructions contents of his manual may cause smoke spillage into the room and other potential hazards. It is always recommended to install strategically placed smoke detectors and to have a fire extinguisher in a convenient location.
- h. Do not open the stove door when operating unless necessary. This will create a dirty, inefficient burn and could allow smoke spillage or sparks to escape.
- i. Do not open the ash drawer access panel when operating unless necessary. This will create a dirty, inefficient burn and could allow smoke spillage or sparks to escape.
- j. Do not permit operation by young children or those unfamiliar with stove's operation.
- k. **Do not service or clean this appliance without disconnecting the power cord.**
- l. If the stove is installed in a room without air conditioning, or in an area where direct sunlight can shine on the unit, it is possible this can cause the temperature of the stove to rise to operational levels; one of the sensors could then make the blowers start on their own. It is recommended that the stove be unplugged when not in use for extended periods of time (i.e. during the summer months).
- m. Burning any solid fuels generates carbon monoxide in low concentration. This gas is evacuated by the exhaust venting system. In higher concentrations, carbon monoxide is toxic and may cause death. To prevent this, ensure that your venting system is gastight.
- n. Use only approved fuels in this stove. Some other fuels may be highly volatile, which may cause more embers to enter the exhaust venting system causing a hazardous situation. Other fuels type, such as charcoal, can create a higher concentration of carbon monoxide leading to potential poisoning.

## 3. MAINTENANCE

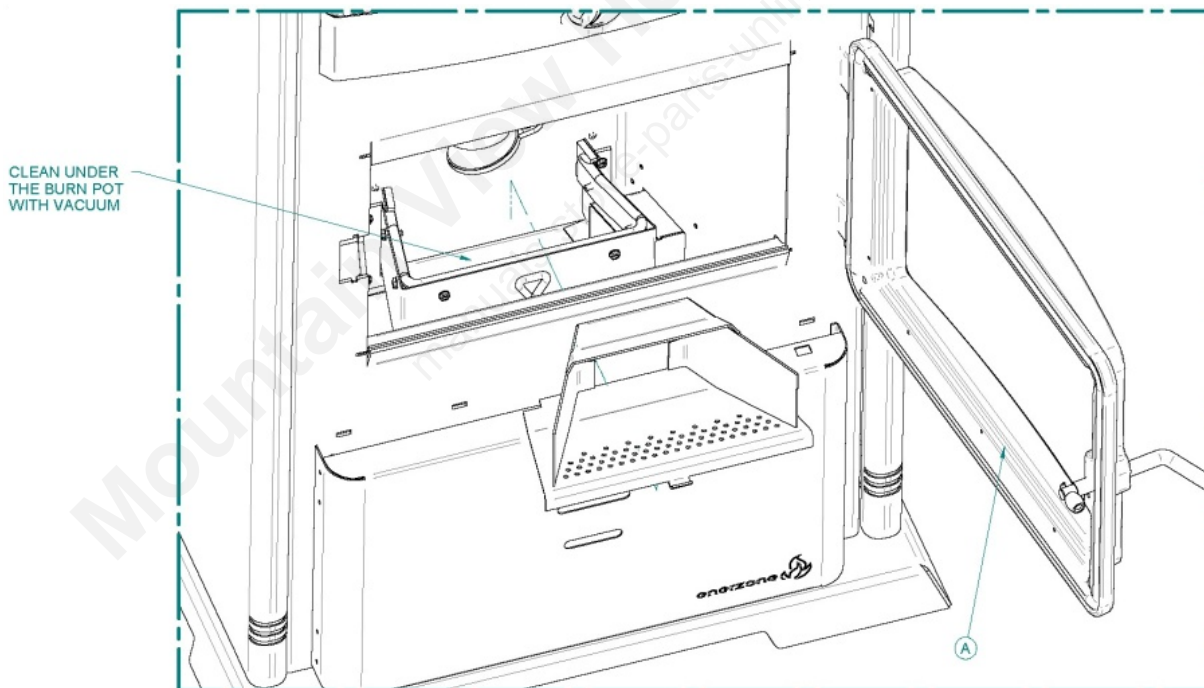
FAILURE TO CLEAN AND MAINTAIN THIS UNIT AS INDICATED CAN RESULT IN POOR PERFORMANCE AND SAFETY HAZARDS. NEVER CLEAN WHEN HOT.

**WARNING:** THE USE OF A DOMESTIC, CENTRAL OR COMMERCIAL VACUUM CLEANER TO PERFORM THE MAINTENANCE OF YOUR PELLET STOVE IS NOT RECOMMENDED. ASH PARTICLES ARE SO FINE THAT IT CAN DAMAGE THE MOTOR OF SUCH VACUUM CLEANERS. MOREOVER, EMBERS THAT ARE STILL HOT MAY CATCH FIRE IN THE USE OF AN ASH VACUUM. THE MODEL CHEETAH II (AC02580) ASH VACUUM IS SPECIALLY DESIGNED FOR THIS USE AND IS HIGHLY RECOMMENDED.

### 3.1. CLEANING THE BURN POT AND THE AIR WASH INLET

The burn pot should be kept clean and its ports should not be clogged with combustion residues. Cleaning the burn pot is simple. To do so, you may use a scraper, a brush or release the clip in front of the burn pot. Then, remove the burn pot by lifting and pulling it out. Once the burn pot is removed you should clean thoroughly inside the burn pot mount with an ash vacuum.

Once the burn pot is clean, vacuum the ashes that may have accumulated in the air wash inlet slot (A) between the bottom glass retainer and the glass. This will allow an optimum air flow along the inside portion of the glass and prevents the glass from sooting-up.

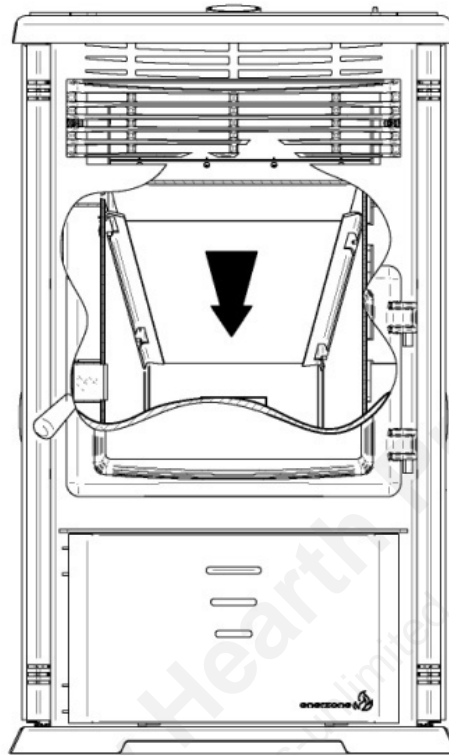


**FIGURE 25**  
Burn Pot

**NOTE:** Inspect burn pot periodically to see that the holes have not become plugged. If so, clean thoroughly.

### 3.2. MAINTENANCE OF THE COMBUSTION CHAMBER, HEAT EXCHANGERS AND BLOWER HOUSING

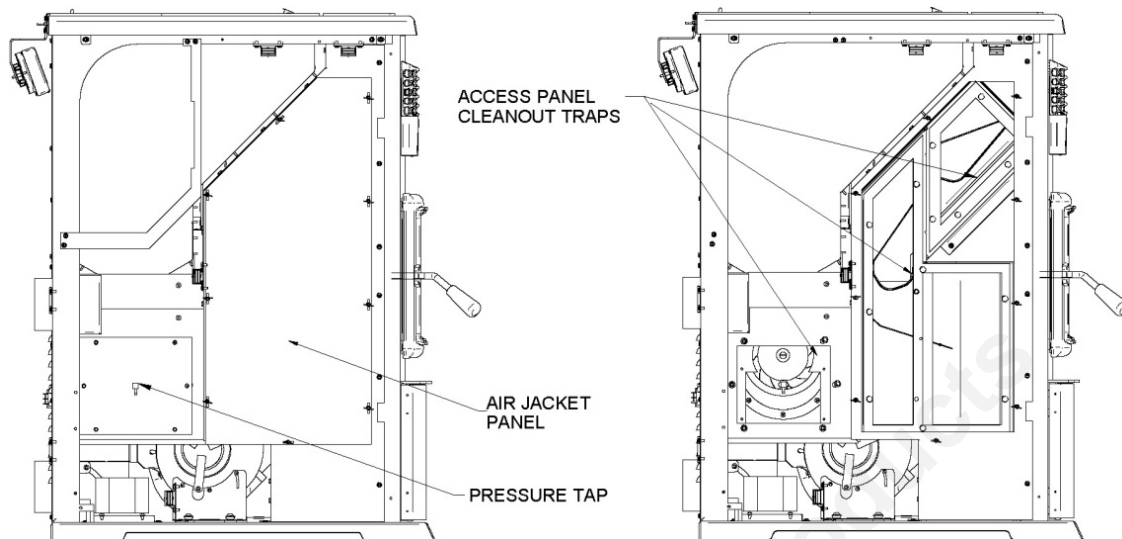
Remove and clean the baffle inside the combustion chamber after burning +/- 10 bags of pellets.



### 3.3. MAINTENANCE OF THE HEAT EXCHANGERS AND BLOWER HOUSING

The heat exchangers should be inspected regularly during the heating season. Easy access is provided:

To access the heat exchangers, remove the decorative panel and the air jacket access panel located on the left hand side of the stove. Then, remove the three clean out trap to perform the maintenance. It is important to start from the top and finish at the bottom. Use a scraper and an ash vacuum to clean the heat exchanger. The use of an ash vac is the most efficient way to collect ashes that have accumulated. Please note that you do not need to repeat the same steps on the right side of the appliance. The right hand side needs to be opened and cleaned only if there is excessive ash accumulation. Exhausted combustion product may also accumulate within the exhaust fan housing and block the pressure switch tap located on the blower's cleanout panel. Disconnect the pressure switch hose and remove the blower's cleanout panel. Then use a mesh or wire brush to clean the tap then blow in the pressure switch hose to make sure it is free of any obstruction. Clean and vacuum any build-up in the exhaust blower housing being very careful not to damage the impellers while cleaning each blades. Should one of the cleanout panel gasket be damaged, it is very important that you replace it in order to prevent leakage of flue gases and soot



**FIGURE 26**  
**Cleanout panel and Pressure**  
**tap location**

### 3.4. VENTING SYSTEM MAINTENANCE

**REGULARLY EXAMINE THE FLUE PIPES, THE JOINTS, AND THE SEALING TRIMS TO ENSURE THAT THE SMOKE AND THE COMBUSTION GASES ARE NOT TRANSPORTED INTO THE AIR DUCTING SYSTEM.**

The most efficient method to sweep the venting system is by using a 4-inch pellet brush. Brush downwards so ash, soot and creosote residues will come off the inner surface and fall at the bottom of the venting system where they can be removed easily. The chimney must be in good condition and kept clean.

**If a significant layer of creosote has accumulated (3mm / 1/8" or more), it must be removed immediately to eliminate the risk of a chimney fire.**

#### 3.4.1. Dealing with a Chimney Fire

Regular chimney maintenance and inspection can prevent chimney fires. If you have a chimney fire, follow these steps:

1. Immediately turn off the stove;
2. Alert your family of the possible danger;
3. If you require assistance, alert your fire department;
4. If possible, use a dry chemical fire extinguisher, baking soda or sand to control the fire. Do not use water as it may cause a dangerous steam explosion;
5. Check outside to ensure that sparks and hot embers coming out of the chimney are not igniting the roof;
6. Do not use the stove again until your chimney and stove have been inspected by a qualified chimney sweep or a Fire Department Inspector;

**CAUTION: CLEANOUT OF THE HEAT EXCHANGER, FLUE PIPE, AND CHIMNEY, IS ESPECIALLY IMPORTANT AT THE END OF THE HEATING SEASON TO MINIMIZE CORROSION DURING THE SUMMER MONTHS, CAUSED BY ACCUMULATED ASH.**

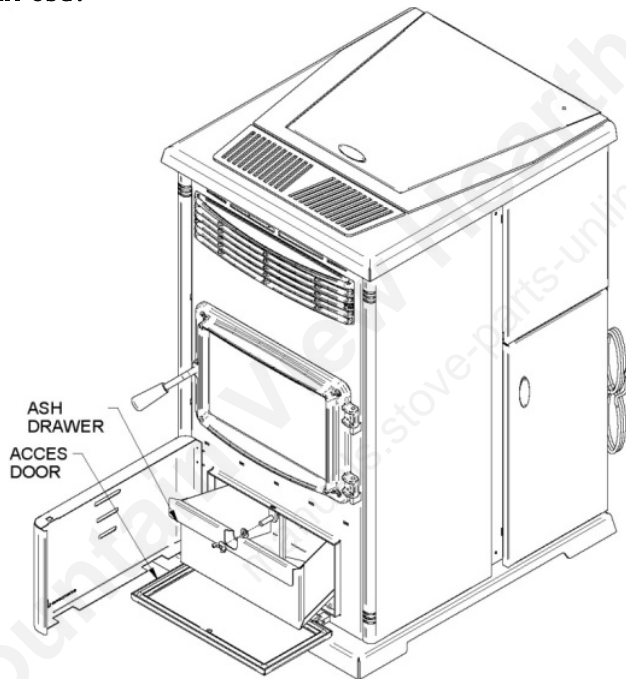
### 3.4.2. Soot and Flyash – Formation and need for removal

The products of combustion will contain small particles of flyash. The flyash will collect in the exhaust venting system and restrict the flow of the flue gases. Incomplete combustion, such as occurs during startup, shutdown, or incorrect operation of the room heater will lead to some soot formation which will collect in the exhaust venting system. The exhaust venting system should be inspected at least once every year to determine if cleaning is necessary.

### 3.5. ASH REMOVAL

In order to remove ashes from the ash drawer, simply unscrew the wing nut, open the access door, and empty the ash drawer.

**Attention, it is important that the ash drawer is in place and the access door is kept closed while the appliance is in use.**



**FIGURE 27  
Ash Drawer**

#### 3.5.1. Ash Disposal and Ash Vacuum Use

Ashes must be placed in a metal container with a tight fitting lid. The closed container should be placed on a non-combustible floor or on the ground, well away from all combustible materials, pending final disposal. This container should not receive any other type of waste. If the ashes are disposed of by burial in soil or otherwise locally dispersed, they should be retained in the closed container until all cinders have been thoroughly cooled.

Once the ashes have been removed, you should take this opportunity to thoroughly vacuum around the ash drawer with an ash vacuum.

### 3.6. DOOR ADJUSTMENT

In order for your stove to operate properly, the door should be adjusted periodically to provide an air tight fit. To adjust:

- Remove the lock pin (spring pin) by pulling and turning it using pliers ("wise grip")
- Turn the handle counter clock wise one turn to increase pressure
- Re-install the lock pin (spring pin) with a small hammer

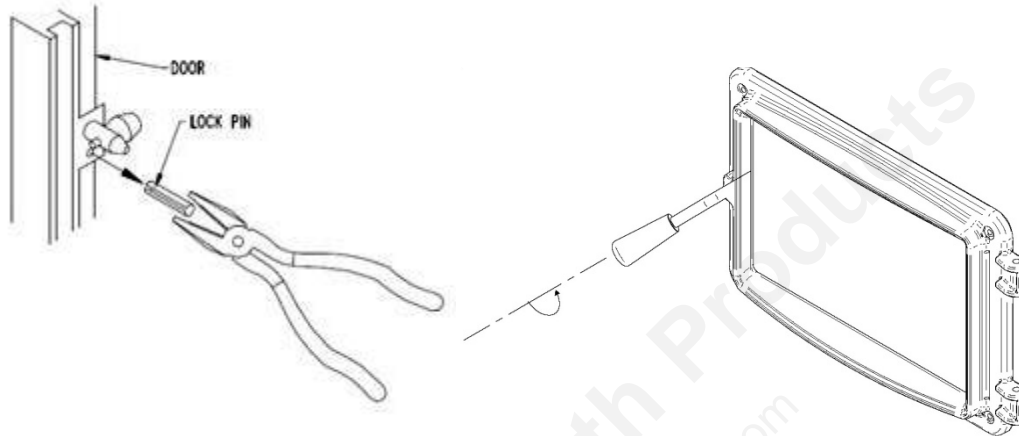


FIGURE 28

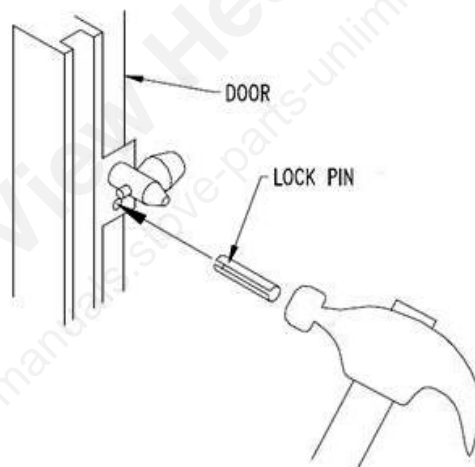


FIGURE 29

### 3.7. DOOR GASKET MAINTENANCE

It is important to maintain the door gasket in good condition. After a while, the gasket will compress and might sag; a door adjustment may then be required. If the door adjustment is not sufficient, replace the door gasket with a genuine one. **If the appliance door is not properly sealed, it will be difficult to keep the door glass clean and combustion gases may leak into the room.**

### 3.8. GLASS CARE

Clean door glass as necessary. The use of a specially designed cleaner is recommended. Your authorized Enerzone dealer can also assist you to choose the right product. Regular household glass cleaners will not clean creosote.

**WARNING: NEVER USE ABRASIVE CLEANERS ON THE GLASS OR DOOR.**

**WARNING: DO NOT CLEAN THE GLASS WHILE IT'S HOT.**

**WARNING: DO NOT ABUSE THE DOOR GLASS BY STRIKING, SLAMMING OR SIMILAR TRAUMA.**

**WARNING: DO NOT OPERATE THE STOVE WITH THE GLASS REMOVED, CRACKED OR BROKEN.**

### 3.9. REMOVAL AND REPLACEMENT OF BROKEN DOOR GLASS

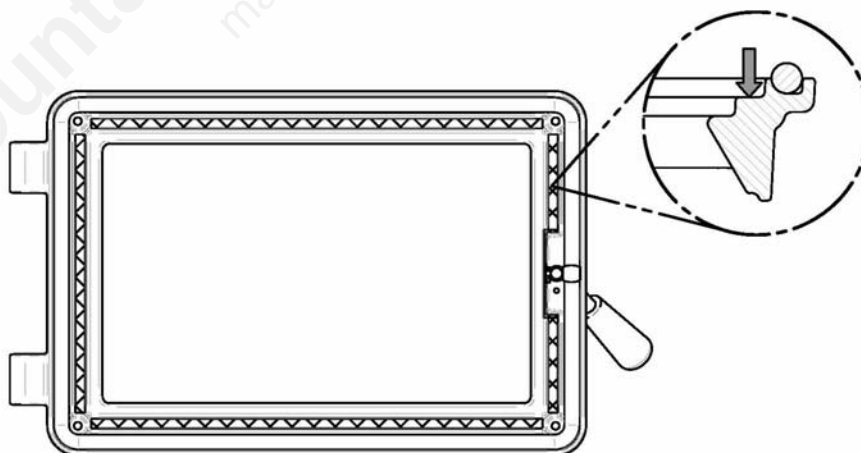
**WARNING: ALWAYS WEAR SUITABLE GLOVES WHILE HANDLING BROKEN GLASS.**

Carefully remove any loose pieces of glass from the doorframe. Dispose of all broken glass properly.

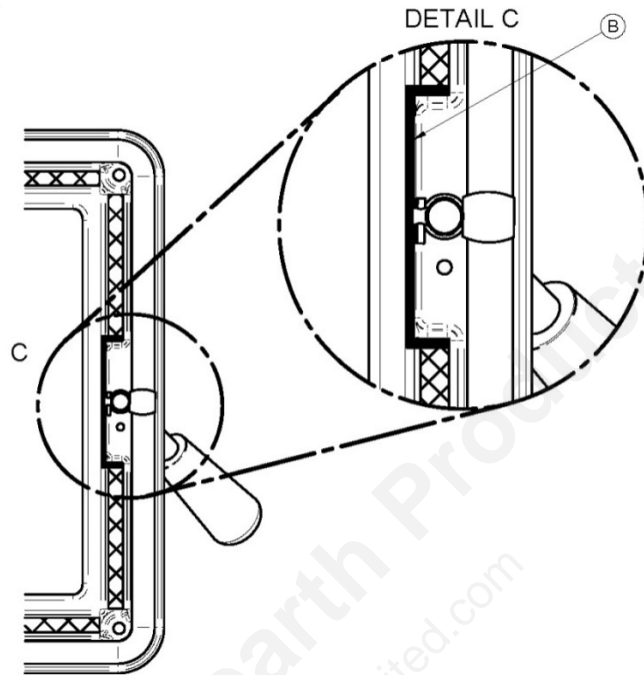
A broken glass must be replaced with an identical ROBAX (ceramic glass) 5 mm thick with the dimensions: 9" 11/64 x 14" 43/64". Your authorized Enerzone dealer can help you to obtain this genuine replacement part.

To replace the glass, use the following procedure:

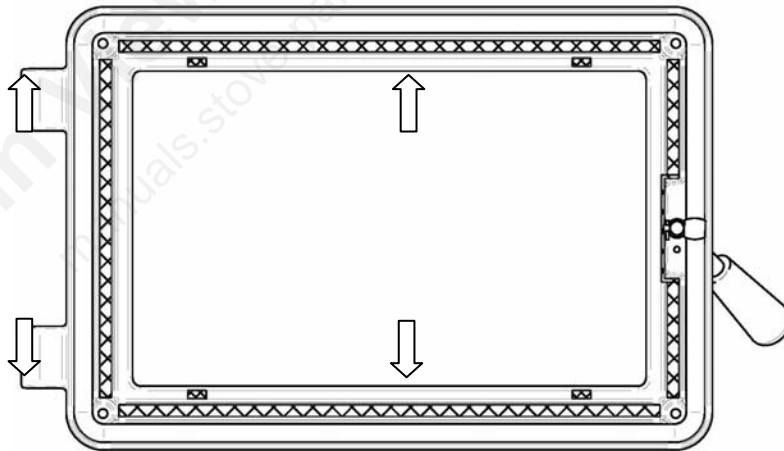
1. Put the door assembly face down on a clean and non abrasive surface (towel, bubble wrap, etc.) to avoid damaging the door.
2. Remove the screws and the 2 glass retainers.
3. Remove the remaining broken glass.
4. Remove the inner door frame adhesive gasket if necessary.
5. To install the new glass, follow the above steps in reverse order.
6. If the old gasket was removed, install a new inner door frame adhesive gasket #40018 as shown in the following figures.



In the handle area, apply the gasket in surrounding the cast iron extrusion to ensure an adequate airtightness. Cut the gasket using cutting pliers.

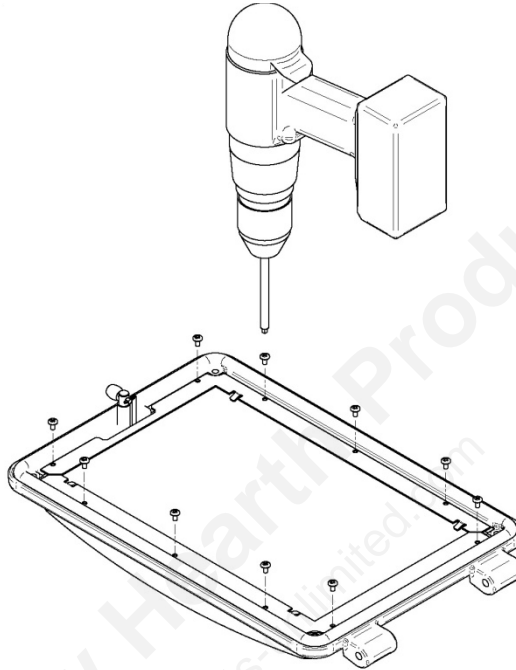


7. Install 4 x ½ inch pieces of #40018 adhesive gasket aligned with each retainer tab to keep the appropriate gap between the glass and the door frame.



8. Install the glass in the door frame making sure it is centered.

9. Set the torque of the power driver at 1/3 of its capacity. Install the retainers using the screws removed in step 2. Start by installing one screw in the centre hole of each retainer, it will help you position the trims. Make sure the glass does not move and remain centered before installing the other screws. Each screw must be snugged against the retainer not overtighten. Once the retainers are secured the tabs should barely touch the glass ...



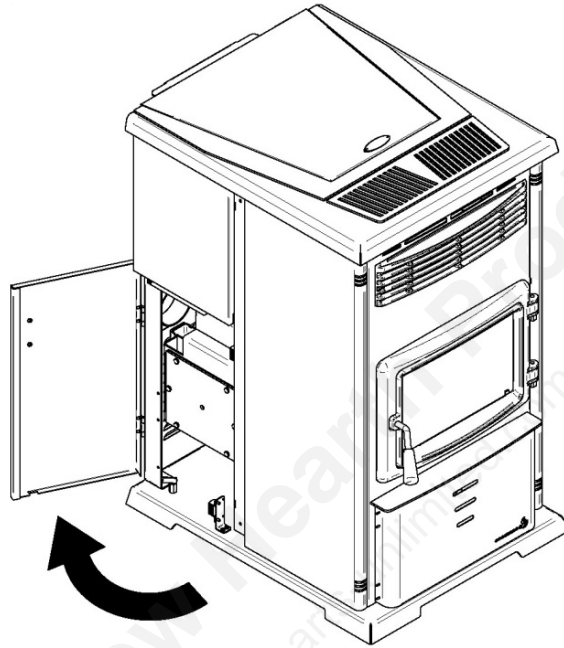
**WARNING: REPLACEMENT GLASS SHOULD ONLY BE PURCHASED FROM A DROLET DEALER (SEE "REPLACEMENT PARTS" SECTION). TEMPERED GLASS OR ORDINARY GLASS WILL NOT WITHSTAND THE HIGH TEMPERATURES OF THE EUROMAX.**

### 3.10. REMOVAL AND REPLACEMENT OF GASKETS

#### EXHAUST BLOWER CLEANOUT TRAP GASKET

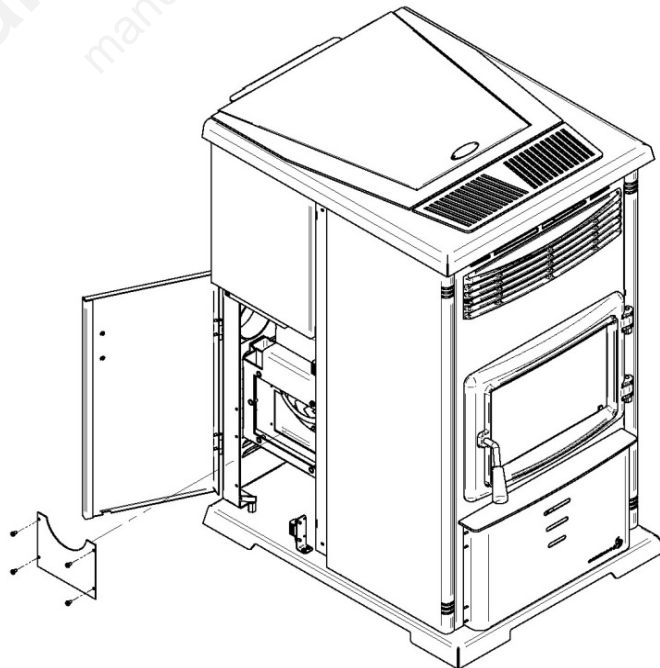
**Step 1:**

Open the rear door located to the left of the appliance. Remove all 6 bolts retaining the exhaust blower cleanout trap. Remove the worn gasket and clean-up the contact surfaces. Keep the bolts for further instructions.



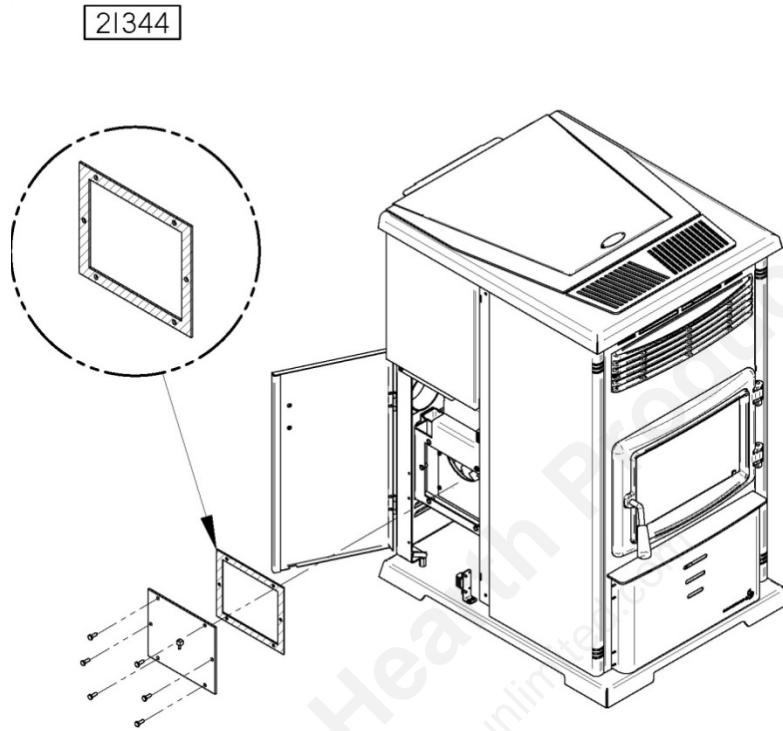
**Step 2:**

Remove all 4 bolts retaining the cleanout plate located inside the exhaust blower cage assembly. Clean-up the dirty area inside the appliance with an ash vacuum. Put back the cleanout plate and its respective bolts in place.



**Step 3:**

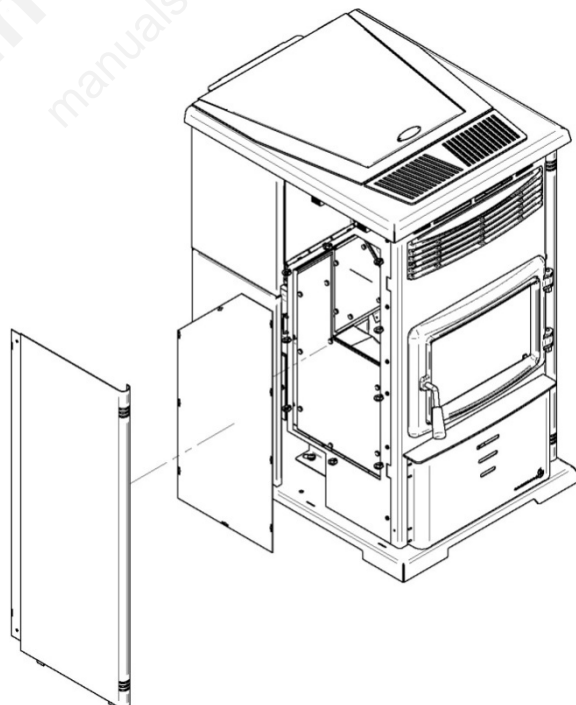
Apply gasket #21344 from AC09190 on the exhaust blower cleanout trap and secure it all with all 6 bolts kept on step 2. Close the rear door.



**FRONT LEFT CLEANING AND REPLACING GASKET**

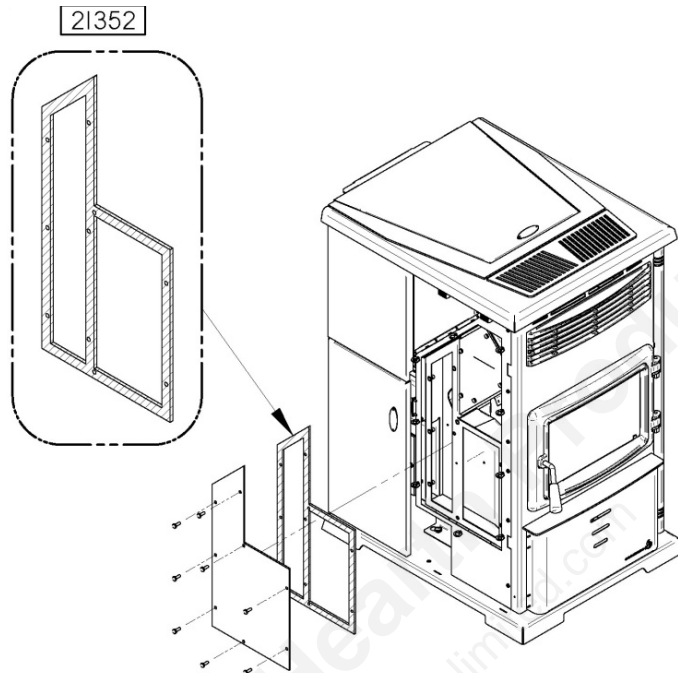
**Step 1:**

Remove the front side shield located to the left of the appliance and take-off the side air jacket access panel by untying the 9 spring clips.



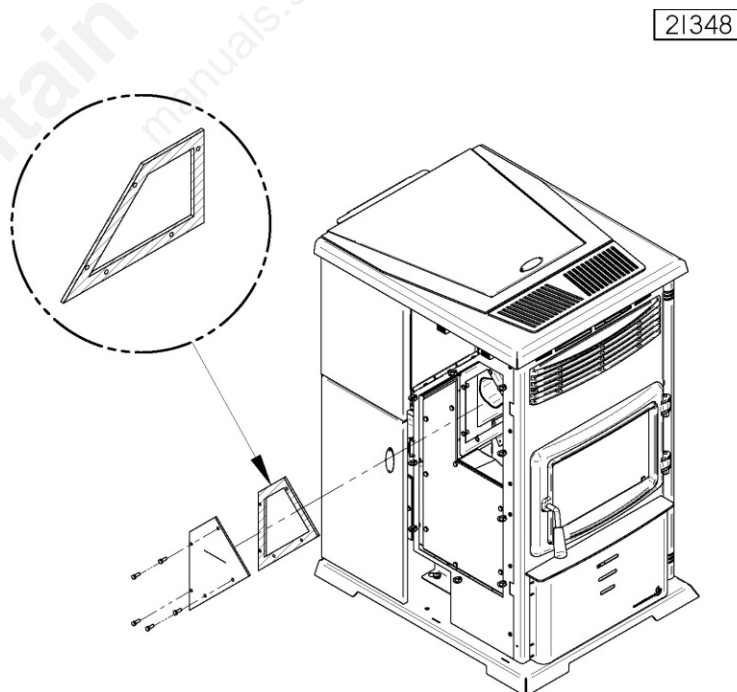
**Step 2:**

Remove all 8 bolts securing the clean out trap. Remove the worn gasket and clean-up the contact surfaces. Clean-up the dirty area inside the appliance with an ash vacuum. Apply gasket #21352 from AC09190 on the clean out trap. Put back in place the clean out trap with its respective bolts.



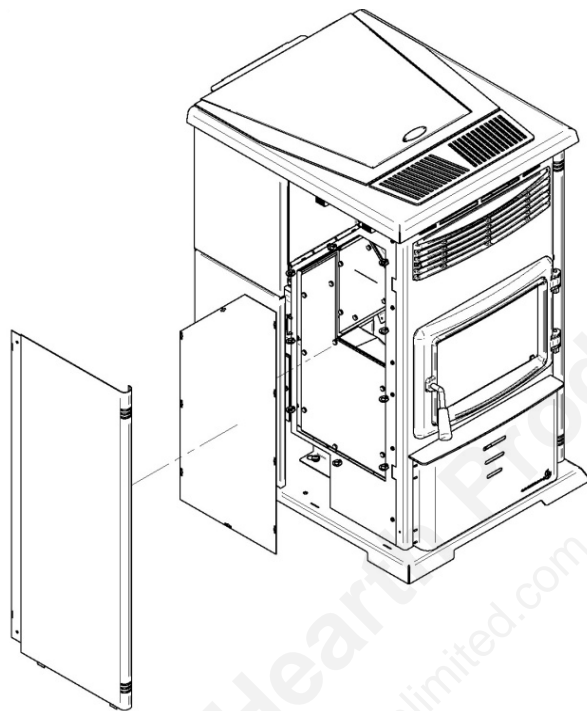
**Step 3:**

Remove all 5 bolts retaining the upper clean out trap. Remove the worn gasket and clean-up the contact surfaces. Clean-up the dirty area inside the appliance with an ash vacuum. Apply gasket #21348 from AC09190 on the clean out trap. Put back in place the clean out trap with its respective bolts.



**Step 4:**

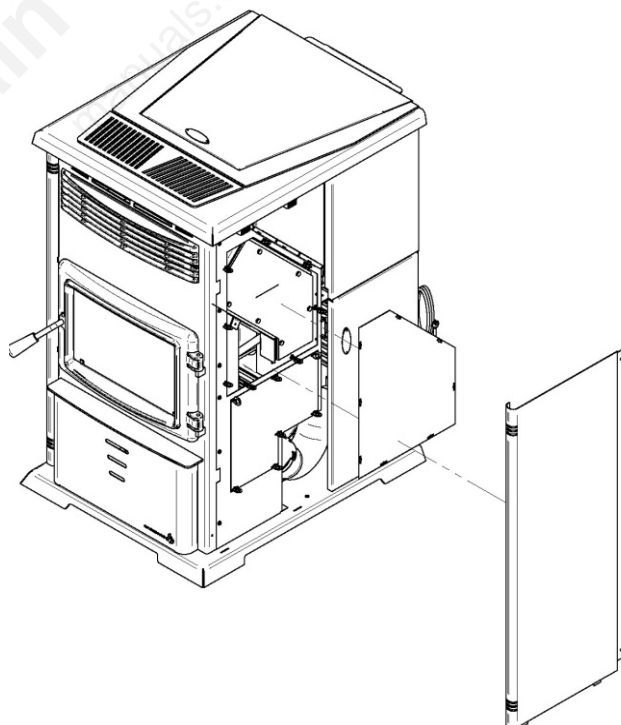
Put back in place the side air jacket access panel and re-attach all 9 spring clips. Put back in place the front side panel located to the left of the appliance.



**RIGHT CLEAN OUT PANEL GASKET**

**Step 1:**

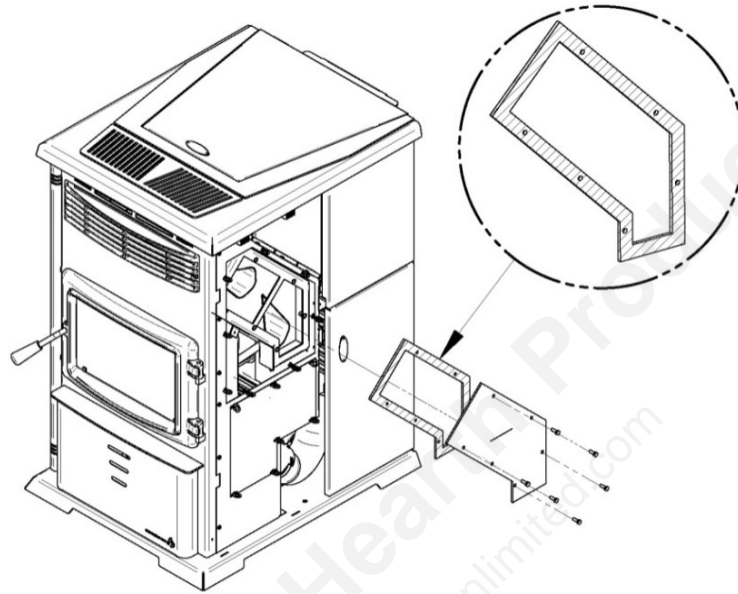
Remove the side shield located to the left of the appliance and take-off the upper air jacket access panel by untying the 8 spring clips.



**Step 2:**

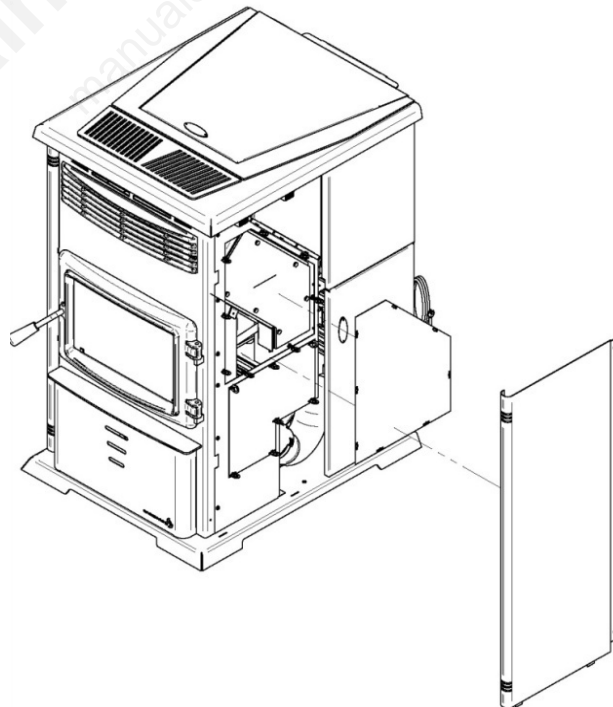
Remove all 6 bolts retaining the right clean out panel. Remove the worn gasket and clean-up the contact surfaces. Clean-up the dirty area inside the appliance with an ash vacuum. Apply gasket #21349 from AC09190 on the clean out panel. Put back in place the clean out panel with its respective bolts.

21349



**Step 3:**

Put back in place the upper air jacket access panel and re-attach all 8 spring clips. Put back in place the side panel on the appliance.



### 3.11. RECOMMENDED MAINTENANCE SCHEDULE

Use this as a guide under average-use conditions.

Components	Weekly or after +/- 500 pounds	Twice a year or after +/- 2 tons	Annually or per 4 tons of pellets
Baffle	Vacuum		
Bottom air wash inlet	Vacuum		
Burn Pot	Brush / Vacuum		
Glass	Clean		
Ash Drawer	Empty / Vacuum		
Combustion Chamber	Vacuum	Vacuum / Brush*	
Heat Exchanger Tubes		Scrape and Vacuum*	
Exhaust Channels (through access traps)		Vacuum*	
Exhaust Blower		Vacuum*	
Combustion Blower		Vacuum*	
Pressure Switch Tap		Brush*	
Venting System		Inspect / Sweep*	Sweep and Clean
Gaskets		Inspect	
Hopper			Empty / Vacuum

*\*Cleaning frequency may vary depending on the type of fuel used. Fuel with a higher ash content will increase cleaning frequency.*

## 4. TROUBLESHOOTING GUIDE

When your stove acts up, your first reaction may be to call for help. This guide may save time and money by enabling you to solve simple problems yourself. Problems can be caused by generally five factors: 1) poor fuel; 2) poor operation or maintenance; 3) poor installation; 4) component failure; 5) factory defect. You can usually solve those problems related to 1 and 2. Your dealer can solve problems relating to 3, 4 and 5. Refer to figures 32 - 34 to help locate indicated parts.

**Should you need to contact your dealer or the manufacturer, please photocopy and fill out the form in Appendix B. Try to answer as many questions as you can. Have it handy when you call. This will help you obtain a much faster service.**

<div style="border: 1px solid black; padding: 10px; margin: 0 auto; width: 80%;"> <div style="border: 1px solid black; padding: 5px; display: inline-block; margin-bottom: 10px;"><b>BLOCKED FLUE</b></div> <p style="text-align: center; margin: 0;">A BLOCKAGE WAS DETECTED BY THE PRESSURE SWITCH</p> <div style="display: flex; justify-content: space-around; margin-top: 10px;"> <div style="border: 1px solid black; border-radius: 10px; padding: 5px 15px;">RESET</div> <div style="border: 1px solid black; border-radius: 10px; padding: 5px 15px;">DETAILS</div> </div> </div>	
<b>Possible Causes:</b>	<b>Possible Remedies:</b> (Unplug stove first when possible)
1. Airflow pressure switch hose or pressure tap for hose are blocked.	Unhook air hose from the airflow switch and blow through it. If air flows freely, the hose and tube are fine. If air will not flow through the hose, use a thin wire to clear the blockage.
2. The air inlet, burn pot, interior combustion air chambers, combustion blower, or exhaust pipe are blocked with ash or foreign material.	Follow all cleaning procedures in the maintenance section of the owner's manual.
3. Vent pipe is incorrectly installed.	Check to make sure vent pipe installation meets the criteria in the owner's manual as well as the pipe manufacturer's recommendations.
4. The airflow pressure switch wire connections are faulty.	Check the connectors attached to the pressure switch.
5. The airflow pressure switch wires are pulled loose at the connector on the wiring harness.	Check to see whether the wires are loose at the connectors.
6. Exhaust blower failure.	This blower must turn on when you start the unit. If it does not, make sure there is power on the connections. If the power is connected, the motor is probably defective; if there is no power, see #7.
7. Control board is not sending power to exhaust blower.	If there is no power going to the blower, check all connections. If all wires are properly connected, you have a defective control board.
8. Control board not sending power to airflow pressure switch.	There should be a 120-volt current going to the air switch after the stove has been on. You will need a technician to perform this test.
9. Airflow pressure switch has failed (very rare).	To test the airflow pressure switch, you need to disconnect the air hose from the blower casing. With the other end still attached to the switch, very gently suck on the loose end of the hose (you may want to completely disconnect the hose from the stove and the switch first and make sure it is clear). If you hear a click, the switch is working. <b>BE CAREFUL: TOO MUCH SUCTION CAN DAMAGE THE SWITCH.</b>

**NO FUEL**

THE EXHAUST  
TEMPERATURE INDICATES  
THAT THERE IS NO FIRE IN  
THE BURN POT

RESET

DETAILS

<b>Possible Causes:</b>	<b>Possible Remedies:</b> (Unplug stove first when possible)
1. The hopper is out of pellets.	Refill the hopper.
2. The burn pot holes are blocked.	Remove the burn pot and clean it thoroughly.
3. The air inlet, interior chambers, or exhaust system is partly blocked.	Follow all cleaning procedures in the maintenance section of the owner's manual.
4. One of the two augers motor has failed.	Remove the auger motor from the auger shaft and try to run the motor separately by pressing the fuel feed button on the control board. Make sure that the hopper lid is not open. If the motor turns, the shaft is jammed on something. If the motor does not turn, the motor is defective or there is a faulty connection with the control board. To remove the auger motor, take the rear louver off the stove body. Loosen the two screws holding the motor to the auger shaft.
5. One of the two the auger shaft is jammed.	Remove the auger shaft from the auger housing. Start by emptying the hopper. Take the rear louver off the stove body. Then take the auger motor off by removing the screws that hold the motor to the auger shaft. Once the motor is out, remove the four screws on the steel plate that holds the auger shaft to the auger housing. Then rotate the bottom end of the auger shaft down towards you until you can pull the shaft down out of the stove. After you have removed the shaft, inspect it for bent flights, burrs, or broken welds. Remove any foreign material that may have caused the jam. Also, check the auger housing for signs of damage such as burrs, rough spots, or grooves cut into the metal that could have caused a jam. Clean the auger housing thoroughly to remove all pellet dust.
6. The thermistor heat sensor has malfunctioned.	The thermistor is a heat sensor located on the exhaust housing. Its function is to tell the control board that the unit has ignited properly by measuring the heat in the exhaust. The pellet stove will not start feeding pellets at the desired heat setting until it has received a signal from the thermistor heat sensor. If the thermistor heat sensor is bad, the unit will stop after the ignition cycle. If this situation occurs, call your dealer or technician.

**FAILED IGNITION**  
 THE EXHAUST  
 TEMPERATURE HAS NOT  
 REACHED ITS START-UP  
 VALUE AFTER TWO  
 IGNITION ATTEMPS

RESET

DETAILS

<b>Possible Causes:</b>	<b>Possible Remedies:</b>
1. Blockage in igniter tube or inlet for igniter tube.	Remove the burn pot and clean it thoroughly. Make sure that all openings are clear. Find the place where the igniter tube comes out of the burn pot housing. It is a small tube located on the back of the burn pot housing. Make sure it is clear. Make sure there is no debris around the igniter element or inside the igniter tube.
2. Defective igniter element.	Supply power directly to the igniter element. Watch the tip of the igniter from the front of the stove. After about 30 seconds, the tip should glow. If it does not, the element is defective and must be replaced. You may need a technician to perform this test.
3. The thermistor heat sensor has malfunctioned.	The thermistor is a heat sensor located on the exhaust housing. Its function is to tell the control board that the unit has ignited properly by measuring the heat in the exhaust. The pellet stove will not start feeding pellets at the desired heat setting until it has received a signal from the thermistor heat sensor. If the thermistor heat sensor is bad, the unit will stop after the ignition cycle. If this situation occurs, call your dealer or technician.
4. The control board is not sending power to the igniter.	Check the voltage going to the igniter during ignition. It should be a full current. If the voltage is lower than full current, check the wiring. If the wiring is functional and properly connected, the board is defective. You will need a technician to perform this test.
5. The pump is not connected properly or isn't working properly	Verify that the plug is connected properly and if the pump is running during the lightning cycle. If the pump isn't working make sure all connections are good.

**IGNITER FUSE**

THE IGNITER FUSE BLEW UP

RESET

DETAILS

<b>Possible Causes:</b>	<b>Possible Remedies:</b>
1. The igniter fuse on the control board has blown.	<p>The igniter or the pump is defective or the wiring harness shorted.</p> <p>Remove the control board cover and check if the F1 fuse appears to have blown. Replace it with a 5 Amp 250V fuse. Plug the stove back on and try to start the unit.</p>



## AUGER FUSE

THE AUGER FUSE BLEW UP

RESET

DETAILS

<b>Possible Causes:</b>	<b>Possible Remedies:</b>
1. The auger jammed, the auger motor is defective or the wiring harness shorted.	Remove the control board cover and check if the F2 fuse appears to have blown. Replace it with a 3 Amp 250V fuse. Plug the stove back and try to run the unit.
2. The auger fuse has blown.	Start by emptying the hopper. Then, remove the auger motor by removing the screws holding the motor to the auger shaft once the motor is out, remove the four screws on the steel plate holding the auger shaft to the auger housing. Then, rotate the bottom end of the auger shaft down towards you until you can pull the shaft down out of the stove. After you have removed the shaft, inspect it for bent flights, burrs, or broken welds. Remove any foreign material that might have caused the jam. Also, check the auger housing for signs of damage such as burrs, rough spots, or grooves cut into the metal that could have caused a jam. Clean the auger housing thoroughly to remove all pellet dust. Repeat the process with the burn pot auger motor.

## UNIT OVERHEAT

AN OVERHEAT ZONE WAS DETECTED ON THE AUGER HOUSING

RESET

DETAILS

<b>Possible Causes:</b>	<b>Possible Remedies:</b>
1. An overheat zone was detected on the auger housing	The L-250 automatic high temperature switch is located on the top of the auger housing. It sends a signal to the control board if the auger housing overheats. Wait until the stove cools down AND THEN INSPECT YOUR UNIT. Improper installation, poor maintenance, or a defective or missing component may be causing the stove to overheat. Reset the stove and restart it. Call a technician if you get this code again.

\*\*\* After 3 attempts, reset is no longer possible, call SBI technical support.

## HOPPER LID OPEN

THE HOPPER LID HAS  
REMAINED OPEN FOR MORE  
THAN 3 MINUTES

RESET

DETAILS

### Possible Causes:

1. The hopper lid has stayed open for more than 3 minutes

### Possible Remedies:

As a security measure, the auger stops turning and feeding pellets as soon as the hopper lid opens. It will resume normal operation as soon as the hopper lid is closed. If the hopper lid stays open for more than 3 minutes, the unit will stop and a code "d" will appear on the control board. Close the hopper lid. Reset the unit and start it again.

If the lid is properly close the hopper lid switch is defective or misconnected

## SMOKE SMELL COMING BACK INTO THE HOME

### Possible Causes:

1. There is a leak in the vent pipe system.

### Possible Remedies:

Inspect all vent pipe connections. This is a pressurized exhaust system. All vent connector joints must be sealed and fastened in accordance with the pellet pipe manufacturer's instructions to ensure consistent performance and avoid smoke and ash spillage.

2. A gasket on the exhaust blower housing or on the clean out trap is in bad condition.

Inspect the gasket on the exhaust blower housing to make sure it is in good condition. Make sure that all clean out trap gaskets are in good condition and all bolts are tight.

## AUGER MOTOR STOP FEEDING PELLETS AND COMES BACK ON

### Possible Causes:

1. The auger motor is overheating and tripping the internal temperature shutoff (thermal protector).

### Possible Remedies:

Start by emptying the hopper. Then, remove the auger motor by removing the screws holding the motor to the auger shaft. Once the motor is out, remove the four screws on the steel plate holding the auger shaft to the auger housing. Then, rotate the bottom end of the auger shaft down towards you until you can pull the shaft down out of the stove. After you have removed the shaft, inspect it for bent flights, burrs, or broken welds. Remove any foreign material that might have caused the jam. Also, check the auger housing for signs of damage such as burrs, rough spots, or grooves cut into the metal that could have caused a jam. Clean the auger housing thoroughly to remove all pellet dust. Repeat the process when the burn pot auger motor.

<ul style="list-style-type: none"> <li>GLASS "SOOTS" UP AT A VERY FAST RATE</li> <li>FLAME IS LAZY, DARK, AND HAS BLACK TIPS</li> <li>AFTER STOVE HAS BEEN ON FOR A WHILE, THE BURNPOT OVERFILLS</li> </ul>	
<b>Possible Causes:</b>	<b>Possible Remedies:</b>
1. Stove or vent pipe is dirty, which restricts airflow through the burn pot.	Follow all cleaning procedure in the maintenance section of the owner's manual.
2. Vent pipe installed improperly.	Check to make sure the vent pipe has been installed according to the criteria in the owner's manual.
3. Burn pot holes are blocked.	Remove the burn pot and clean it thoroughly.
4. Blockage in air intake pipe.	Visually inspect the air intake pipe that leads into the burn pot for foreign material.
5. Combustion blower is not working properly.	Check if the blower is still working (separately – bypassing the control board). Make sure that there is not any obstruction in the fresh air kit and into the air intake tube.
6. Bad pellets (Applies to "GLASS SOOTS UP AT A VERY FAST RATE" Only)	The brand of pellets or the batch of pellets that are being used may be of poor quality. If possible, try a different brand of pellets. You might also want to try a brand that is made from a different type of wood (softwood vs. hardwood). Different woods have different characteristics when being burned. Your pellets may also be too humid. Make sure you store your fuel properly, in a dry ventilated area.

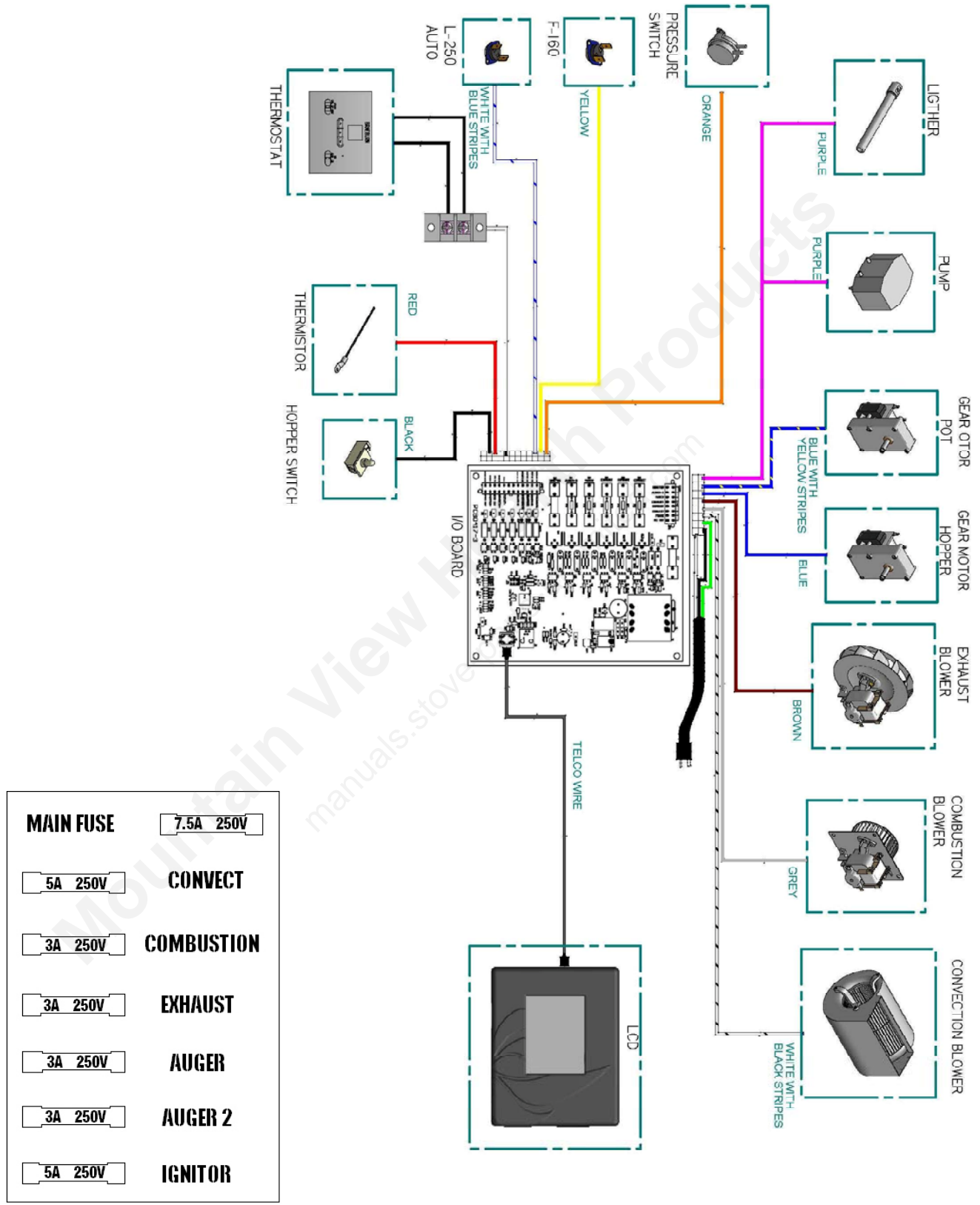
<b>THE CONTROL BOARD DOES NOT DISPLAY ANY INFORMATION.</b>	
<b>Possible Causes:</b>	<b>Possible Remedies :</b>
1. A fuse on the control board has blown.	Remove the control board. Check if the F7 fuse on the back of it appears to be bad. Replace it with a 7.5 Amp 250 Volt fuse. Plug the stove back in and try to run the unit.

<div style="border: 1px solid black; padding: 10px; width: fit-content; margin: 0 auto;"> <div style="border: 1px solid black; padding: 5px; display: inline-block; margin-bottom: 10px;">POWER LOSS</div> <p style="margin: 0;">POWER WAS INTERRUPTED WHILE BURNING</p> <div style="border: 1px solid black; padding: 5px; display: inline-block; margin-top: 10px;">RESET</div> </div>	
<b>Possibles Causes:</b>	<b>Possibles Solutions:</b>
Warning generated by a power failure while the stove was running.	The stove will restart on the initial setting once it cools off. Note: For a short power failure (less than 5 seconds), the stove will continue to function at the selected speed.

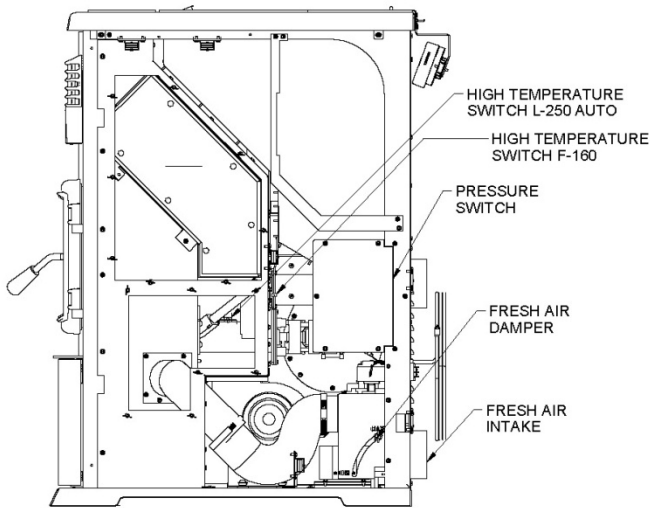
### SMOKE SMELL OR SOOT BUILD-UP

Because it is a pellet-burning device, your Euromax may emit a faint wood-burning odor. If this increases beyond normal, or if you notice an unusual soot build-up on walls or furniture, check your exhaust system carefully for leaks. All joints should be properly sealed. Also clean your stove, following instructions in "MAINTENANCE". If problem persists, contact your dealer.

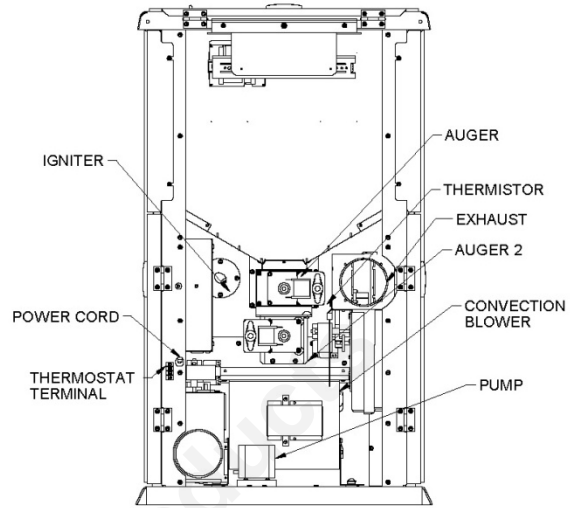
# 5. ELECTRICAL DIAGRAM



**FIGURE 31**



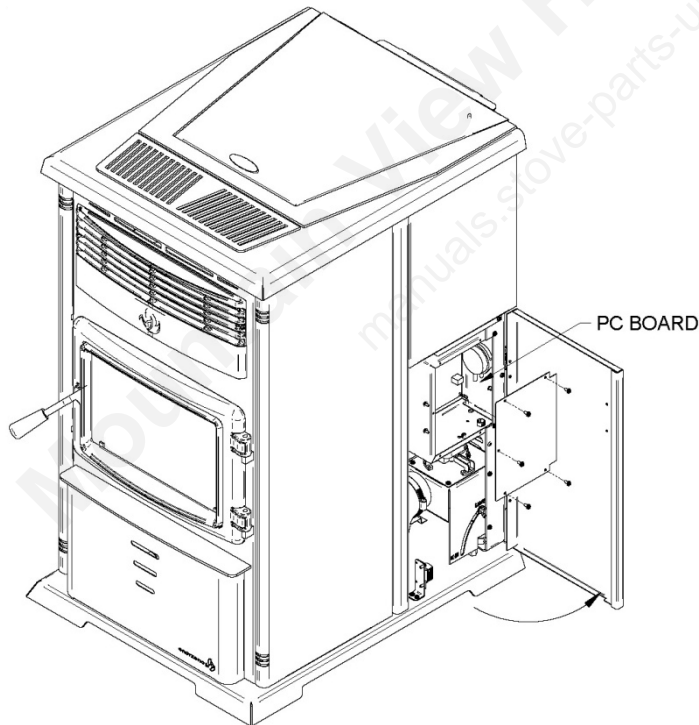
**FIGURE 32**



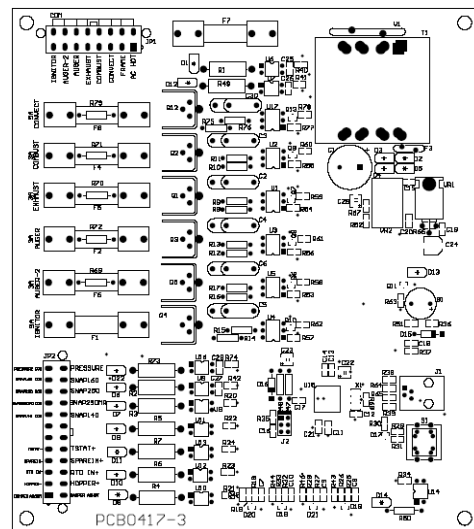
**FIGURE 33**

**5.1 FUSE ACCESS:**

All fuses are located inside the pc board box. You must remove the pc board cover to access the fuse. To do so, simply remove the 5 screws securing it in place. Make sure you put the pc board box back in place before you restart the unit.



**FIGURE 34**

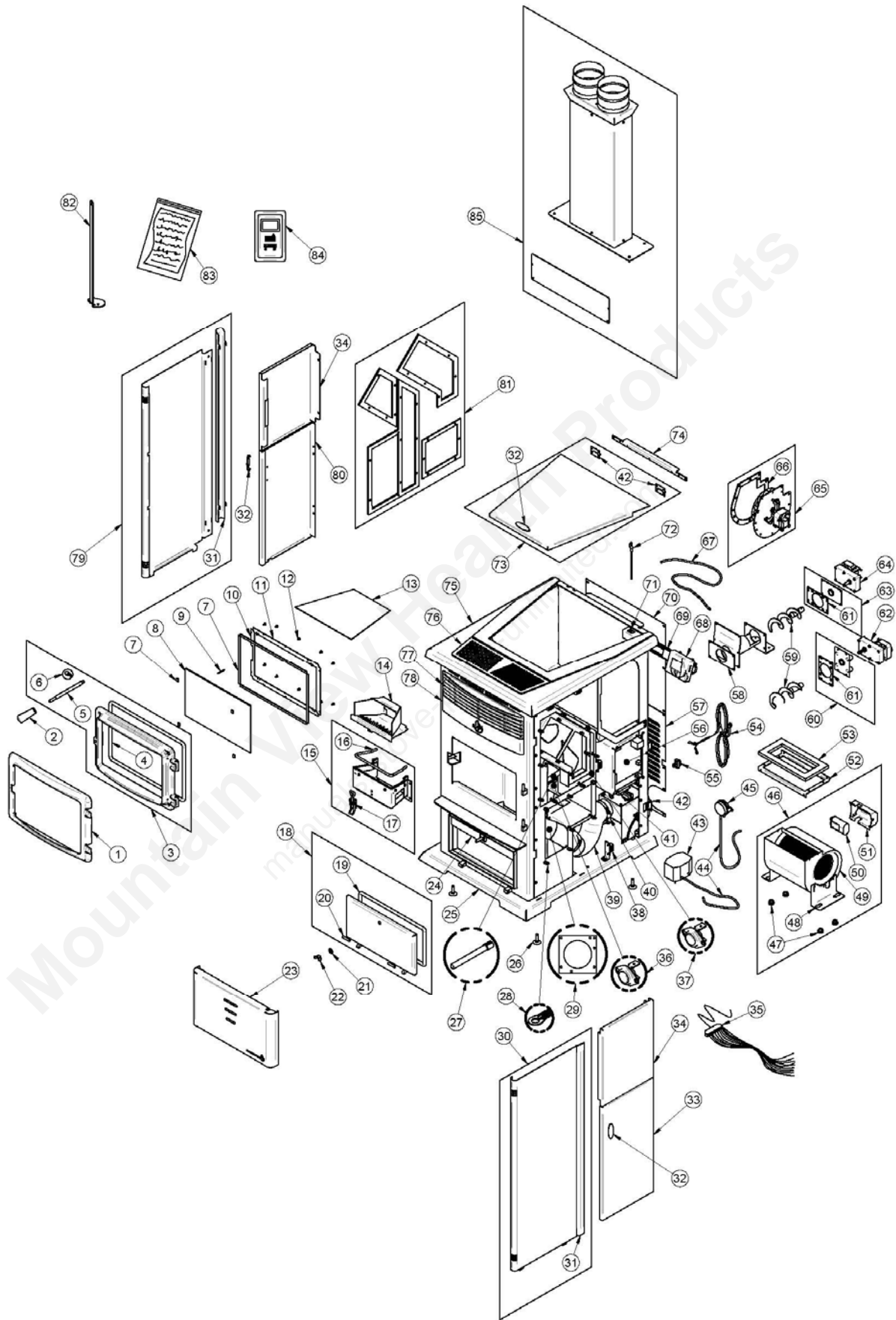


## 6. REPLACEMENT PARTS

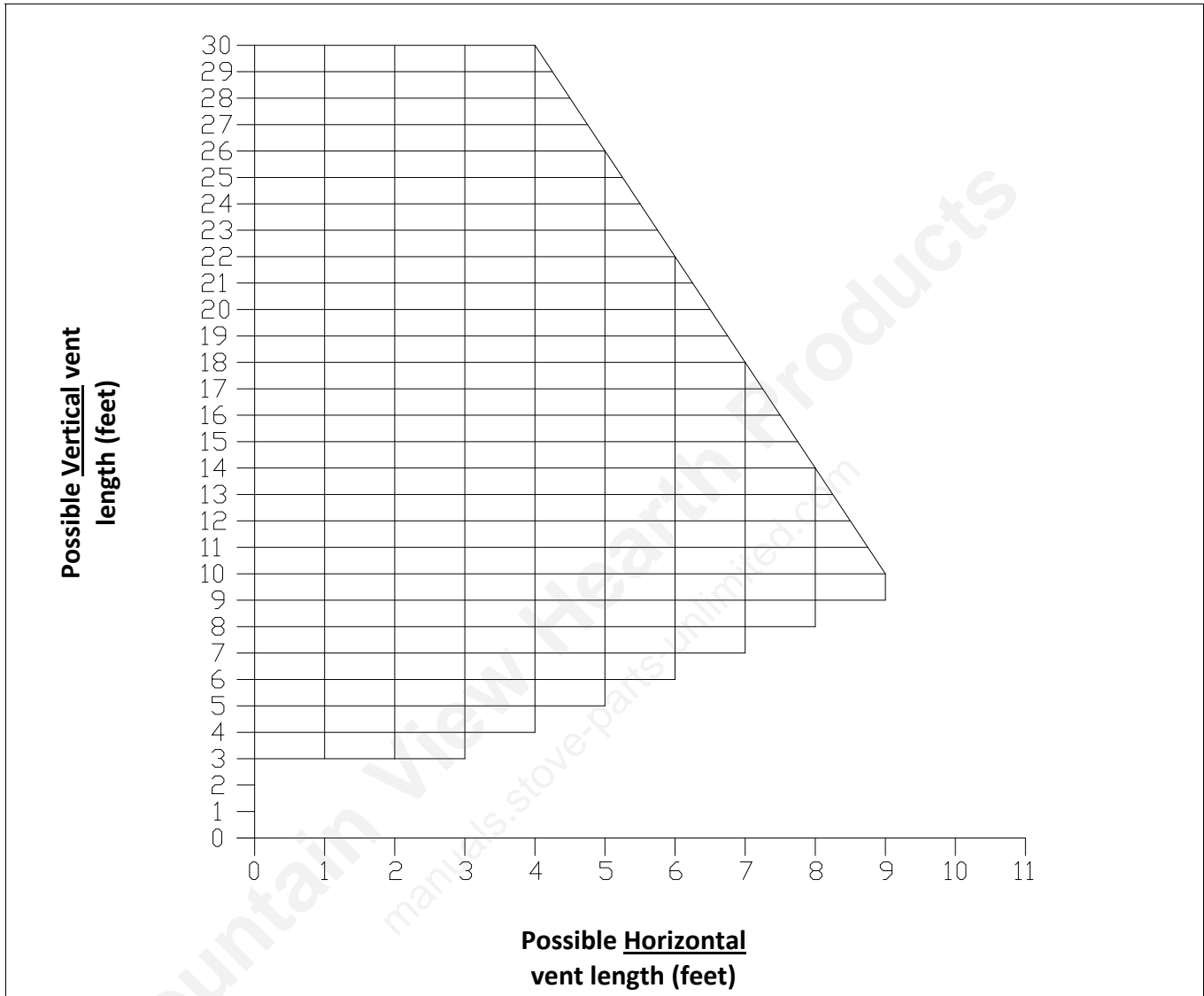
Contact an Authorized ENERZONE Dealer to obtain any of these parts. Never use substitute materials. Use of non-approved parts can result in poor performance and safety hazards.

#	ITEM	PART #	QTY
1	BLACK CAST IRON DOOR OVERLAY	AC01220	1
1	BRUSHED NICKEL CAST IRON DOOR OVERLAY	AC01222	1
2	BLACK ROUND WOODEN HANDLE	30569	1
3	DOOR ASSEMBLY	SE24179-01	1
4	SILICONE AND 1/2" X 8' BLACK GASKET REPLACEMENT KIT (DOOR)	AC06000	1
5	DOOR HANDLE	PL62296	1
6	DOOR LATCH KIT	AC09185	1
7	SELF-ADHESIVE 1/8" X 3/8" GASKET HB26	40018	4.8583
8	EUROMAX REPLACEMENT GLASS	PL62418	1
9	SPRING TENSION PIN 5/32" DIA X 1 1/2" LONG	30101	1
10	BOTTOM GLASS RETAINER	PL62414	1
11	TOP GLASS RETAINER	PL62413	1
12	SCREW #8 - 32 X 5/16" TRUSS QUADREX ZINC	30124	10
13	BAFFLE	PL62412	1
14	COMBUSTION POT ASSEMBLY	SE62254	1
15	BURN POT SUPPORT ASSEMBLY	SE62302	1
16	ROUND GASKET AND SILICONE KIT 5/16" X 6.6'	AC06300	1
17	FIRE POT LATCH	30686	1
18	ASH DRAWER ACCESS DOOR	SE62325	1
19	BLACK 1/2" ROUND X 9' GASKET KIT WITH ADHESIVE	AC06900	1
20	PIN 5/16" x 1 1/2"	30341	2
21	ZINC WASHER ID 13/32" X OD 13/16"	30205	1
22	WING NUT 3/8"-16	30416	1
23	ASH DRAWER ACCESS COVER	SE62318	1
24	ASH DRAWER	SE62290	1
25	BUILD TO ORDER	99999	1
26	LEVELING BOLT 3/8-16 X 1 1/2"	30050	4
27	500W - 120V IGNITER	44133	1
28	SPRING CLIP	30710	24
29	FRESH AIR INTAKE TUBE GASKET	21345	1
30	DECORATIVE RIGHT SIDE ASSEMBLY	SE62316	1
31	DECORATIVE COLUMN	PL62317	2
32	HOPPER LID HANDLE	30693	3
33	RIGHT SIDE DECORATIVE DOOR	PL62322	1
34	UPPER SIDE DECORATIF PANEL	PL62315	2
35	MAIN CONTROL BOARD WIRE HARNESS	60326	1
36	THERMODISC 36T11 L250-25 AUTOMATIC	44059	1
37	THERMODISC 36T12 F160	44058	1
38	DOUBLE MAGNET	30454	8
39	2 FOLD ALUMINUM LINER 3" X 14" COMPRESSED TO 7"	21077	1
40	3" TO 4" STAINLESS STEEL COLLAR	49400	2
41	COMBUSTION BLOWER 120V-60Hz	44104	1
42	HINGE 2" X 1-1/2"	30013	6
43	AIR PUMP ASSEMBLY (500 PCM, 115v, 60Hz, 1100 TPM)	SE60047	1
44	3/8" X 42" SILICONE HOSE	49606	2
45	PRESSURE SWITCH	44029	1
46	BLOWER WITH CAPACITOR (500 PCM, 115v, 60Hz, 1100 TPM)	SE44108	1

#	ITEM	PART #	QTY
47	BLOWER ANTI-VIBRATION CUSHION	30335	4
48	RIGHT BLOWER MOUNT	PL62359	2
49	BLOWER (500 CFM, 115v, 60Hz, 1100 RPM)	44108	1
50	CAPACITOR 10MF	60323	1
51	CAPACITOR HOUSING	PL62420	1
52	BLOWER WOOL RETAINER	PL62308	1
53	WOOL SEAL FOR BLOWER	21350	1
54	POWER CORD 96" X 18-3	60013	1
55	THERMOSTAT TERMINAL	60036	1
56	6 OUPUT MOTHER BOARD	44138	1
57	REAR LOUVER	PL62314	1
58	PRIMARY CHUTE GASKET	21195	1
59	AUGER	24030	2
60	GEAR MOTOR BRACKET	24233	1
61	AUGER SUPPORT INSULATION	21193	2
62	GEAR MOTOR FOR PELLET STOVE 3.5 RPM	44109	1
63	AUGER BUSHING PLATE	PL62281	1
64	BLOWER (500 CFM, 115v, 60Hz, 1100 RPM)	44108	1
65	EXHAUST FAN ASSEMBLY	SE62293	1
66	EXHAUST BLOWER GASKET	21194	1
67	JUNCTION WIRE MAIN CONTROL BOARD TO LCD	60327	1
68	EUROMAX TOUCH SCREEN ELECTRONIC BOARD (LCD)	44129	1
69	LCD BRACKET	SE62421	1
70	UPPER REAR PANEL	PL62349	1
71	HOPPER LID SAFETY SWITCH	44098	1
72	THERMISTOR	44095	1
73	HOPPER LID ASSEMBLY	SE62348	1
74	HOPPER STOPPER	PL62351	1
75	ENERZONE TOP ASSEMBLY	SE62324	1
76	TOP DECORATIVE GRILL	SE62336	1
77	CAST IRON UPPER GRILLE EUROZONE 35 (DRILL & TAP)	24177	1
78	FRONT DECORATIVE PANEL	SE62334	1
79	DECORATIVE LEFT SIDE ASSEMBLY	SE62331	1
80	LEFT SIDE DECORATIVE DOOR	PL62321	1
81	MAINTENANCE GASKET KIT- PELLET HEATER	AC09190	1
82	SCRAPER	PL62342	1
83	EUROMAX INSTRUCTION MANUAL KIT	SE45432	1
84	MILLIVOLT WHITE THERMOSTATS	44048	1
85	HOT AIR PLENUM KIT - 4" x 10"	AC01330	1



## APPENDIX A HORIZONTAL AND VERTICAL VENT CHART



For example, let's imagine an installation consisting of a horizontal vent coming out at the back of the stove on a total distance of 8 feet. This horizontal run is followed by a Tee and a 6-foot vertical rise. This type of installation is not acceptable. As you can see, the vent termination is clearly outside the allowed configuration zone on the chart because the venting system proposed **does not have at least one foot of vertical rise for each foot of horizontal run.**

Instead, if the installation consisted of a horizontal vent coming out at the back of the stove on a total distance of 4 feet, followed by a Tee and a 6-foot vertical rise, it would be acceptable. The installation end should be within the allowable configuration zone on the chart since it would have at least one foot of vertical rise for each foot of horizontal run. Furthermore, the total vertical rise would be at least 3-foot high.

**WARNING:** To reduce the risk of smoke spillage, never terminate with a horizontal run. If your system terminates with a horizontal run, add at least 3 feet of vertical rise.

## APPENDIX B INSPECTION FORM

INSPECTION AND REPAIR FORM	Fabrikant de poêle international inc. Stove Builder International Inc. 250, rue de Coenhague, St-Augustin-de-Desmaures (Québec) G3A 2H3 tél. : (418) 878-3040 Télécopie : (418) 878-3001 Courriel : tech@sbi-international.com				<b>INSTALLATION DIAGRAM</b>		
	<b>DRAW YOUR INSTALLATION</b>						
	<b>1 SQUARE = 1 FOOT</b>						
	Installation		int.	<input type="checkbox"/>	ext.	<input type="checkbox"/>	
	Installation size		4	<input type="checkbox"/>	3	<input type="checkbox"/>	
	Stove location			Basement	<input type="checkbox"/>	Main floor	<input type="checkbox"/>
	Name Address City Province / State Country Home telephone Work telephone Purchase date Model number Serial number Installation date Installer name Installer telephone Type of pellets Thermostat                      Yes <input type="checkbox"/> No <input type="checkbox"/> Outside air                              Yes <input type="checkbox"/> No <input type="checkbox"/> Ignition gasket / 2 magniglass    Yes <input type="checkbox"/> No <input type="checkbox"/>				<b>Equivalent vent length calculation table</b>		
					Equivalent vent length (EVL)		
					Qty	Type of pipe	EVL
					1	T or 90°	5 feet
1					45° elbow	3 feet	
1 feet					Horiz. Length	1 feet	
1 feet					Vert. Length	0.5 feet	
<b>Always use 4" pipe. Never use more than 30 feet of Equivalent Vent Length (EVL).</b>							
<b>The longer the run of pipe in your installation, the more restriction there is in the system.</b> <b>Minimum vertical length: 3 feet</b>							
<b>CLEANING</b>							
<b>PART</b>	DAILY	+/- 10 bags	+/- 25 bags	+/- 50 bags			
Exchanger	<input type="checkbox"/> YES <input type="checkbox"/> NO						
Hopper			<input type="checkbox"/> YES <input type="checkbox"/> NO				
Evacuation blower			<input type="checkbox"/> YES <input type="checkbox"/> NO				
Blower blades				<input type="checkbox"/> YES <input type="checkbox"/> NO	<b>Always use 4" pipe. Never use more than 30 feet of Equivalent Vent Length (EVL).</b>  <b>The longer the run of pipe in your installation, the more restriction there is in the system.</b> <b>Minimum vertical length: 3 feet</b>		
Pressure system			<input type="checkbox"/> YES <input type="checkbox"/> NO				
Burn pot	<input type="checkbox"/> YES <input type="checkbox"/> NO						
Evacuation system				<input type="checkbox"/> YES <input type="checkbox"/> NO			
Gaskets			<input type="checkbox"/> YES <input type="checkbox"/> NO				
<b>INDICATE APPLIANCE CODE</b>				<b>DESCRIPTION OF THE PROBLEM</b>			
<b>Appliance code</b>							

## APPENDIX C

### LCD INTERFACE MOUNTING

#### Step 1

The LCD mounting bracket is located in the hopper of the appliance and is preassembled to be installed in a right hand side configuration when facing the unit. If you are using the right hand side configuration go to the following step. You also have the option of installing the LCD mounting bracket on the left hand side on the back of the unit. To reverse the assembly to a left side configuration, extend the rail with the LCD support (E) in order to access the two screws (A) which secures the rail mechanism to the mounting bracket. Remove the screws, rotate the rail 180° and reassemble the rail to the mounting bracket using the screws previously removed.

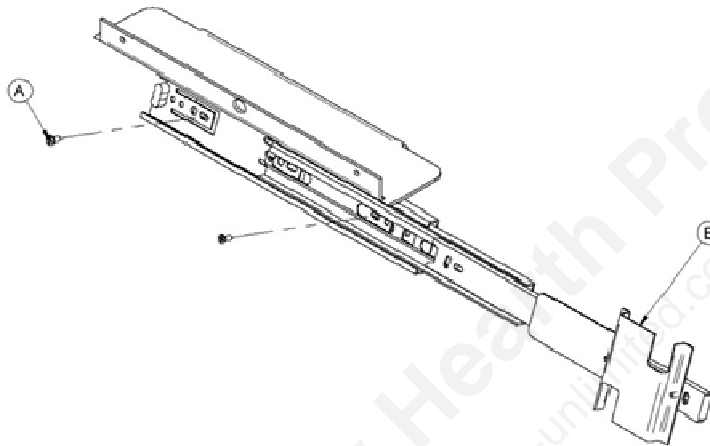


FIGURE 35

#### Step 2

Remove the screws (C) located on the top edge of the back of the appliance. Secure the mounting bracket (B) in place with the same screws.

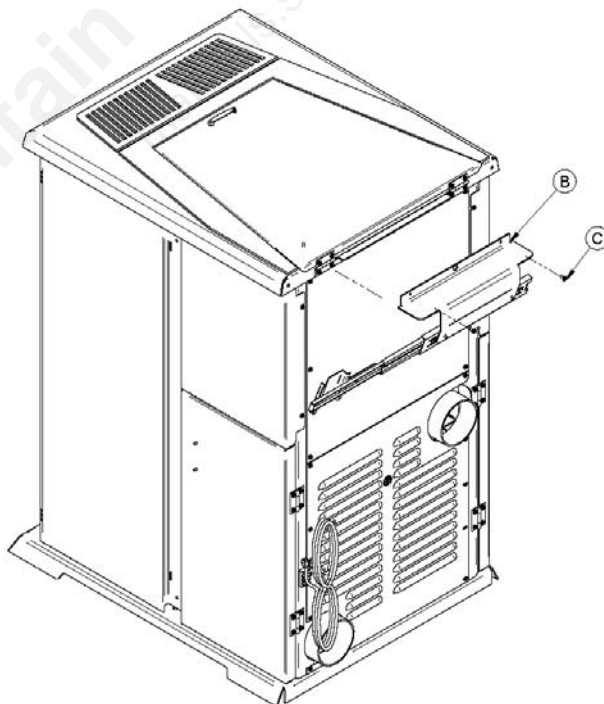
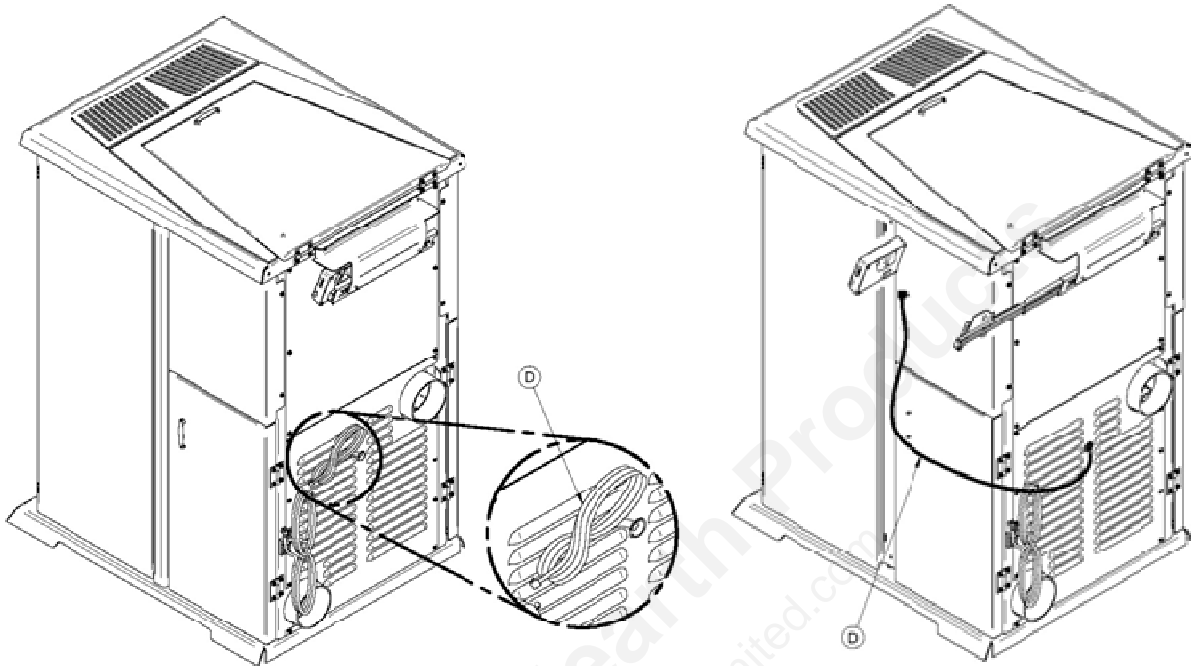


FIGURE 36

### Step 3

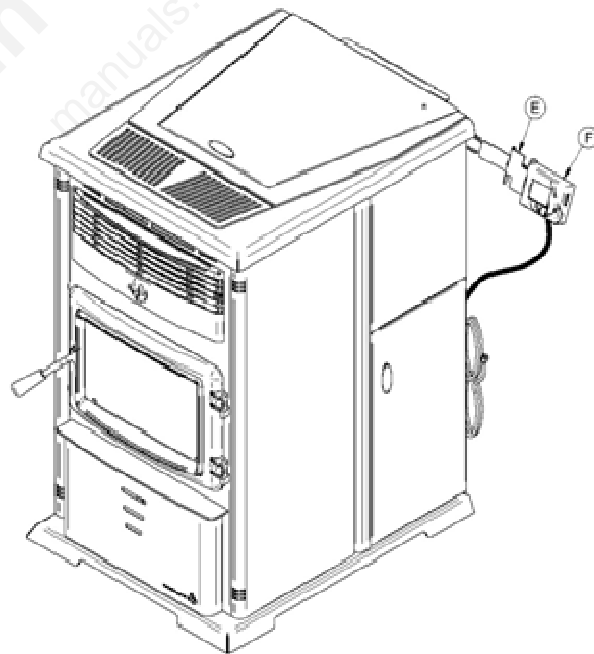
Take the Telco black wire (D) which is located in the middle of the rear bottom panel and plug it into the back of the LCD touch screen interface receptacle.



**FIGURE 37**

### Step 4

Finally, secure the LCD touch screen housing (F) on the rail (E).



**FIGURE 38**

## ENERZONE LIMITED LIFETIME WARRANTY

The warranty of the manufacturer extends only to the original consumer purchaser and is not transferable. This warranty covers brand new products only, which have not been altered, modified nor repaired since shipment from factory. Proof of purchase (dated bill of sale), model name and serial number must be supplied when making any warranty claim to your ENERZONE dealer.

**This warranty applies to normal residential use only. Damages caused by misuse, abuse, improper installation, lack of maintenance, over firing, negligence or accident during transportation, power failures, downdrafts, or venting problems are not covered by this warranty.**

This warranty does not cover any scratch, corrosion, distortion, or discoloration. Any defect or damage caused by the use of unauthorized parts or others than original parts void this warranty. An authorized qualified technician must perform the installation in accordance with the instructions supplied with this product and all local and national building codes. Any service call related to an improper installation is not covered by this warranty.

The manufacturer may require that defective products be returned or that digital pictures be provided to support the claim. Returned products are to be shipped prepaid to the manufacturer for investigation. If a product is found to be defective, the manufacturer will repair or replace such defect. Transportation fees to ship the product back to the purchaser will be paid by the manufacturer. Repair work covered by the warranty, executed at the purchaser's domicile by an authorized qualified technician requires the prior approval of the manufacturer. Labour cost and repair work to the account of the manufacturer are based on predetermined rate schedule and must not exceed the wholesale price of the replacement part. All parts and labour costs covered by this warranty are limited according to the table below.

The manufacturer at its discretion may decide to repair or replace any part or unit after inspection and investigation of the defect. The manufacturer may, at its discretion, fully discharge all obligations with respect to this warranty by refunding the wholesale price of any warranted but defective parts. The manufacturer shall in no event be responsible for any special, indirect, consequential damages of any nature, which are in excess of the original purchase price of the product. A one-time replacement limit applies to all parts benefiting from a lifetime coverage. This warranty applies to products purchased after October 1<sup>st</sup>, 2011.

DESCRIPTION	WARRANTY APPLICATION	
	PARTS	LABOUR
Combustion chamber (welds only), castings, heat exchanger (welds only), auger, and ceramic glass (thermal breakage only*).	Lifetime	4 years
Plating* (defective manufacture) – subject to limitations above.	Lifetime	n/a
Stainless steel firebox components, surrounds and heat shields, ash drawer, pedestal, and trims (aluminum extrusions).	5 years	3 years
Carbon steel firebox components, burn pot, glass retainers, and handle assembly.	3 years	2 years
Blowers, igniter, PC board, auger motor, heat sensors, switches, wiring, rheostat, and other controls.	2 years	1 year
Paint (peeling), gaskets, insulation, ceramic logs, masonry-like panels, and ceramic fibre blankets.	1 year	n/a

*\*Pictures required*

Shall your unit or a components be defective, contact immediately your **ENERZONE** dealer. Prior to your call make sure you have the following information necessary to your warranty claim treatment:

- Your name, address and telephone number;
- Serial number and model name as indicated on the nameplate fixed to the back of your unit;
- Bill of sale and dealer's name;
- Nature of the defect and any relevant information.

**Before shipping your unit or defective component to our plant, you must obtain from your ENERZONE dealer an Authorization Number. Any merchandise shipped to our plant without authorization will be refused automatically and returned to sender.**