

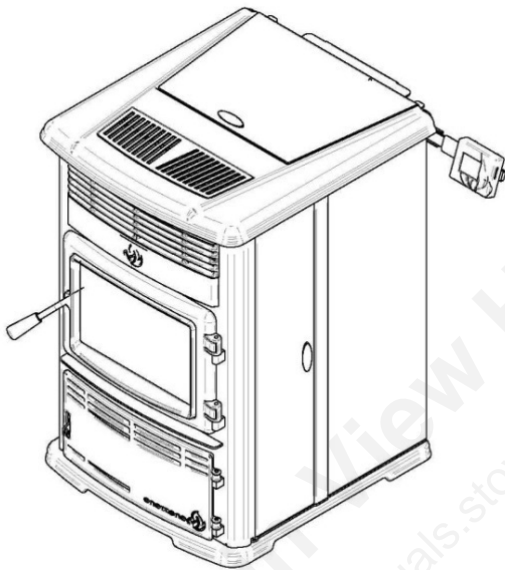

# INSTALLATION AND OPERATION MANUAL

Safety tested according to ULC S627, UL1482 and ASTM E1509 by Intertek Testing Services and according to Oregon Administrative Rules for Mobile Homes 814-23-900 through 814-23-909

## EUROSTAR



[www.enerzone-intl.com](http://www.enerzone-intl.com)  
**Stove Builder International Inc.**  
250, rue de Copenhague,  
St-Augustin-de-Desmaures  
(Quebec) Canada G3A 2H3

Tel: (418) 878-3040 Fax: (418) 878-3001

**CONTACT LOCAL BUILDING OR FIRE OFFICIALS ABOUT RESTRICTIONS AND INSTALLATION INSPECTION REQUIREMENTS IN YOUR AREA.**

**PLEASE READ THIS ENTIRE MANUAL BEFORE INSTALLATION AND USE OF THIS PELLET FUEL-BURNING ROOM HEATER. FAILURE TO FOLLOW THESE INSTRUCTIONS COULD RESULT IN PROPERTY DAMAGE, BODILY INJURY OR EVEN DEATH.**

**READ AND KEEP THIS MANUAL FOR REFERENCE**

**PROFESSIONAL INSTALLATION IS HIGHLY RECOMMENDED**



*This manual is available for free download on the manufacturer's web site. It is a copyrighted document. Re-sale is strictly prohibited. The manufacturer may update this manual from time to time and cannot be responsible for problems, injuries, or damages arising out of the use of information contained in any manual obtained from unauthorized sources.*

## THANK YOU FOR CHOOSING THIS ENERZONE PELLETT STOVE

As one of North America's largest and most respected pellet stove, wood stove and fireplace manufacturers, Stove Builder International takes pride in the quality and performance of all its products. We want to help you get maximum satisfaction as you use this product.

In the pages that follow you will find general advice on pellet heating, detailed instructions for safe and effective installation, and guidance on how to get the best performance from this stove as you build and maintain your pellet heating system.

We highly recommend that our pellet burning hearth products be installed and serviced by professionals who are certified in the United States by NFI (National Fireplace Institute®) or in Canada by WETT (Wood Energy Technology Transfer) or in Quebec by APC (Association des Professionnels du Chauffage).

Congratulations on making a wise purchase.

### **REGISTER YOUR WARRANTY ONLINE**

To receive full warranty coverage, you will need to show evidence of the date you purchased your stove. Keep your sales invoice. We also recommend that you register your warranty online at:

<http://enerzone-intl.com/warranty-registration.aspx>

Registering your warranty online will help us to quickly track the information we need about your stove.

## Table of Contents

<b>1</b>	<b>INTRODUCTION.....</b>	<b>5</b>
1.1	<i>About Pellet Heating.....</i>	5
1.1.1	Top 10 Reasons for Buying a Pellet Stove.....	5
1.2	<i>Eurostar Specifications.....</i>	6
1.3	<i>Overall Exterior Dimensions.....</i>	7
<b>PART A – INSTALLATION.....</b>		<b>8</b>
<b>2</b>	<b>Installation Safety Information.....</b>	<b>8</b>
2.1	<i>Installation Warnings, Cautions and Recommendations.....</i>	8
2.2	<i>Regulations Covering Pellet Stove Installation.....</i>	10
2.3	<i>Before Operating Your Stove.....</i>	10
<b>3</b>	<b>Clearances to Combustible Material.....</b>	<b>11</b>
3.1	<i>Location of the Certification Label.....</i>	11
3.2	<i>Minimum Clearances to Combustibles.....</i>	11
3.3	<i>Back Wall Installation.....</i>	12
3.4	<i>Corner Installation.....</i>	12
3.5	<i>Ceiling Clearances.....</i>	12
3.6	<i>Floor Protection.....</i>	13
<b>4</b>	<b>Venting system.....</b>	<b>14</b>
4.1	<i>General.....</i>	14
4.2	<i>Recommendations.....</i>	14
4.3	<i>Equivalent Vent Length (EVL).....</i>	14
4.4	<i>Termination Location.....</i>	15
4.4.1	Permitted Termination Location.....	16
4.5	<i>Installation Configurations.....</i>	17
4.5.1	Installation Warnings, Cautions and Recommendations Reminder.....	17
4.5.2	Through Wall Installation (Main Floor or Basement).....	18
4.5.3	Through Roof Installation.....	19
4.5.4	Through a Prefabricated Chimney.....	20
4.5.5	Through an Existing Masonry Fireplace.....	21
4.5.6	Through an Existing Masonry Chimney.....	22
<b>PART B - OPERATION.....</b>		<b>23</b>
<b>5</b>	<b>General information.....</b>	<b>23</b>
5.1	<i>Operation Warnings, Cautions and Recommendations.....</i>	23
5.1.1	Zone Heating and How to Make It Work for You.....	25
5.2	<i>Combustible.....</i>	26
5.2.1	Proper Fuel.....	26
5.2.2	Where to Store Bags of Pellets.....	26
<b>6</b>	<b>Stove controls.....</b>	<b>27</b>
6.1	<i>General Information.....</i>	27
6.1.1	LCD Touch Screen Controls, Operation and Configuration.....	27
6.1.2	Configuration and Operation Diagram.....	29
6.1.3	Selecting the Language.....	29
6.1.4	Viewing Statistics.....	29
6.1.5	Changing Temperature Unit (°F or °C).....	29
6.1.6	Adjusting the Combustion Level (Heat Output).....	30
6.1.7	Convection Fan Speed Reduction (Optional).....	31

6.1.8	Selecting Manual or Thermostat Mode.....	32
6.1.9	Selecting the Pilot Cycle.....	33
6.1.10	Filling or Purging Auger Housing .....	34
<b>7</b>	<b>Stove operation.....</b>	<b>35</b>
7.1	<i>First Startup</i> .....	35
7.2	<i>Everyday Startup</i> .....	35
7.3	<i>Running Out of Pellets</i> .....	35
7.4	<i>Refilling</i> .....	35
7.5	<i>Shutting Down Procedure</i> .....	36
7.6	<i>Signs of an Overheating Stove</i> .....	36
<b>8</b>	<b>Maintenance .....</b>	<b>37</b>
8.1	<i>Stove Maintenance</i> .....	37
8.1.1	Recommended Maintenance Schedule .....	37
8.1.2	Cleaning the Baffle, the Heat Exchangers and the Combustion Chamber.....	38
8.1.3	Cleaning the Burn Pot.....	38
8.1.4	Ash Removal .....	40
8.1.5	Cleaning the Air Wash System.....	41
8.1.6	Glass Care.....	41
8.1.7	Replacement of Broken Door Glass .....	41
8.1.8	Door Gasket Maintenance .....	42
8.1.9	Door Adjustment .....	42
8.1.10	Exhaust Channel and Exhaust Blower Maintenance. ....	42
8.2	<i>Venting System Maintenance</i> .....	44
8.2.1	Dealing With a Chimney Fire.....	44
8.2.2	Soot and Fly Ash .....	44
<b>9</b>	<b>Troubleshooting .....</b>	<b>45</b>
9.1	<i>Validating Status</i> .....	45
9.2	<i>Testing Components</i> .....	46
9.3	<i>Main Error Codes, Possible Causes and Solutions</i> .....	47
<b>10</b>	<b>Wiring Diagram .....</b>	<b>54</b>
<b>11</b>	<b>Fuses Access.....</b>	<b>55</b>
<b>12</b>	<b>Component Location .....</b>	<b>56</b>
<b>13</b>	<b>EXPLODED VIEW AND Replacement parts.....</b>	<b>57</b>
	<b>APPENDIX A: HORIZONTAL AND VERTICAL VENT CHART .....</b>	<b>61</b>
	<b>APPENDIX B: LCD SLIDING BRACKET MOUNTING.....</b>	<b>63</b>
	<b>APPENDIX C: FLAME CHARACTERISTICS .....</b>	<b>65</b>
	<b>APPENDIX D: INSTALLING A THERMOSTAT .....</b>	<b>67</b>
	<b>APPENDIX E: MOBILE HOME INSTALLATION .....</b>	<b>69</b>
	<b>APPENDIX F: COMBUSTION AIR SUPPLY .....</b>	<b>70</b>
	<b>ENERZONE LIMITED LIFETIME WARRANTY .....</b>	<b>72</b>

# 1 INTRODUCTION

## 1.1 About Pellet Heating

Pellet stoves offer a dramatic improvement in the convenience of heating with solid fuel. Wood pellets are handled in bags and are therefore easily and cleanly stored. A single loading of a pellet stove can provide long hours of warmth. Pellet stoves also provide a special comfort associated with wood burning. The combination of fans delivering warm air currents and the direct comfort of radiant heat provides special satisfaction on a cold winter day. The heat provided is even and constant, due to the auto fuel feed responding to owner settings. Pellet stoves also offer strong environmental benefits; pellets not only reduce dependence on finite supplies of fossil fuels like oil and gas, but they also put to good use materials that would otherwise unnecessarily and expensively add to our waste disposal problems.

In addition, pellet stoves burn very cleanly and offer the lowest emissions of unwanted pollutants of all solid fuel burning appliances.

### 1.1.1 Top 10 Reasons for Buying a Pellet Stove

- Fuel is relatively cheap, easy to handle and store
- Installation is relatively inexpensive and flexible
- Can be thermostatically controlled
- Can run for long hours without the need to refuel
- Heat output is steady because fuel feed is regulated
- Provides powerful convection heat
- Has the lowest emissions of all solid fuels
- Reduces our dependence on fossil fuels
- Pellets are a renewable fuel
- Wood pellets are made of 100% residual matter (saw dust). This creates added-value from waste that would otherwise end up in a landfill.

## 1.2 Eurostar Specifications

Fuel Type	Wood pellets, Wood and Hay pellets, Bark pellets and Switch Grass pellets.
Test Standards (safety)	ULC S627, ASTM E1509 and UL 1482
Heating capacity range*	500 to 2400 sq ft (46 to 223 m <sup>2</sup> )
Output BTU range**	From 8 500 BTU to 50 000 BTU
Hopper capacity**	70 lb (32 Kg)
EPA Status	< 2.5 g/h
Approximate Burn Time*	13 to 40 hours
Shipping Weight	420 lb (190 kg)
Overall Exterior Dimensions	24 3/16" W x 33 3/4" D x 36" H (614 mm x 857 mm x 914 mm)
Vent system size	3" or 4" depending on EVL (see <b>Section 4.3 Equivalent Vent Length (EVL)</b> )
Baffle material	Stainless Steel
Burn rate	1.5 lb to 5.5 lb per hour
Energy consumption	3A for ignition cycle 1.8A for maximum continuous operation
Electrical requirements	120VAC 15A
Control board fuses	<ul style="list-style-type: none"> <li>- Main: 7.5A-250V fast-blow fuse</li> <li>- Convection blower: 5A-250V fast-blow fuse</li> <li>- Combustion blower: 3A-250V fast-blow fuse</li> <li>- Exhaust blower: 3A-250V fast-blow fuse</li> <li>- Auger motor #1: 3A-250V fast-blow fuse</li> <li>- Auger motor #2: 3A-250V fast-blow fuse</li> <li>- Igniter: 5A-250V fast-blow fuse</li> </ul>

\* *Burn time and heating capacity may vary subject to location in home, chimney draft, chimney diameter, locality, heat loss factors, climate, fuels and other variables.*

\*\* *This can vary depending on pellet size, length, and diameter.*

### 1.3 Overall Exterior Dimensions

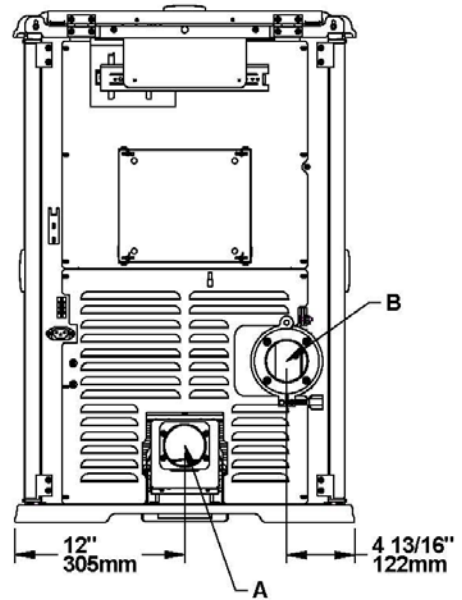
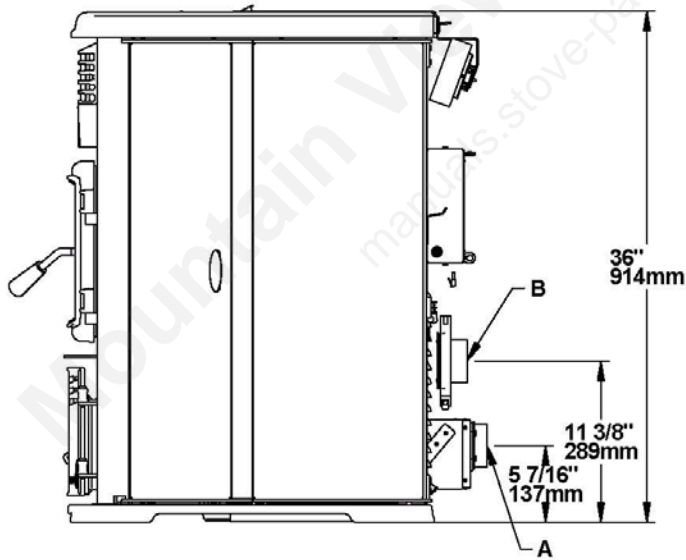
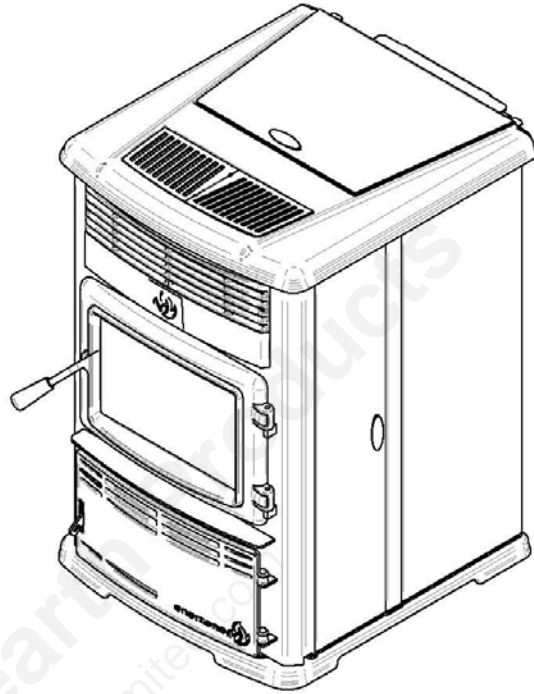
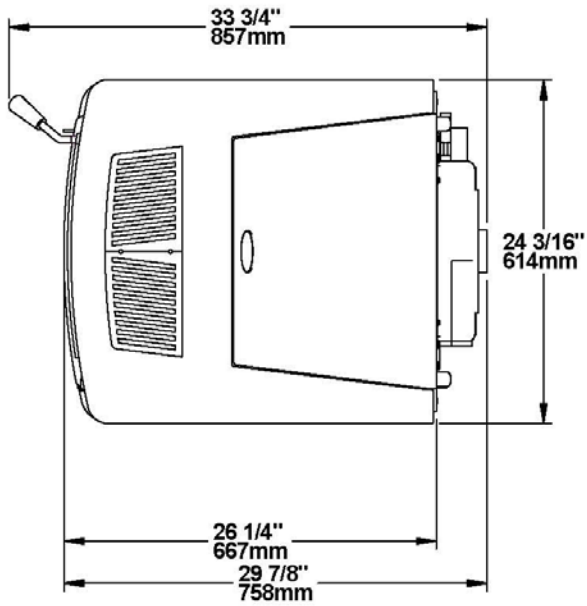

A: FRESH AIR INTAKE    B: EXHAUST

## **PART A – INSTALLATION**

### **2 INSTALLATION SAFETY INFORMATION**

#### **2.1 Installation Warnings, Cautions and Recommendations**

- **PROFESSIONAL INSTALLATION IS HIGHLY RECOMMENDED.**
- **YOU MAY NEED TO OBTAIN A BUILDING PERMIT FOR THE INSTALLATION OF THIS STOVE AND ITS VENTING SYSTEM. CONSULT YOUR MUNICIPAL BUILDING DEPARTMENT OR FIRE DEPARTMENT BEFORE INSTALLATION TO DETERMINE THE NEED TO OBTAIN ONE. WE RECOMMEND THAT YOU ALSO INFORM YOUR HOME INSURANCE COMPANY TO FIND OUT IF THE INSTALLATION WILL AFFECT YOUR POLICY.**
- **THIS STOVE MUST BE CONNECTED TO A STANDARD 120V. 60 HZ GROUNDED ELECTRICAL OUTLET. DO NOT USE AN ADAPTER PLUG OR SEVER THE GROUNDING PLUG. DO NOT ROUTE THE ELECTRICAL CORD UNDERNEATH, IN FRONT OR OVER THE STOVE.**
- **IF THIS STOVE IS NOT PROPERLY INSTALLED, A HOUSE FIRE MAY RESULT. TO REDUCE THE RISK OF FIRE, FOLLOW THE INSTALLATION INSTRUCTIONS EXACTLY.**
- **BURNING ANY SOLID FUELS GENERATES CARBON MONOXIDE IN LOW CONCENTRATION. THIS GAS IS EVACUATED BY THE VENTING SYSTEM. IN HIGHER CONCENTRATIONS, CARBON MONOXIDE IS TOXIC AND MAY CAUSE DEATH. TO PREVENT THIS, ENSURE THAT YOUR VENTING SYSTEM IS AIRTIGHT.**
- **THIS STOVE IS MOBILE HOME APPROVED AND REQUIRES INSTALLATION OF A FRESH AIR KIT, SOLD SEPARATELY. THE STOVE MUST BE ATTACHED TO THE STRUCTURE OF THE MOBILE HOME AND THE STRUCTURAL INTEGRITY OF THE MOBILE HOME FLOOR, WALL, AND CEILING/ROOF MUST BE MAINTAINED. DO NOT INSTALL IN A SLEEPING ROOM OF A MOBILE HOME.**
- **THIS STOVE IS NOT RECOMMENDED TO BE INSTALLED IN A SLEEPING ROOM.**
- **THIS STOVE HAS BEEN DEVELOPED AND BUILT FOR RESIDENTIAL SUPPLEMENTARY HEAT SOURCE. COMMERCIAL AND INDUSTRIAL USE IS PROHIBITED AND WILL VOID THE WARRANTY.**
- **THE INFORMATION GIVEN ON THE CERTIFICATION LABEL AFFIXED TO THE STOVE ALWAYS OVERRIDES THE INFORMATION PUBLISHED IN ANY OTHER MEDIA (OWNER’S MANUAL, CATALOGUES, FLYERS, MAGAZINES AND/OR WEB SITES).**
- **CONNECT THIS STOVE ONLY TO A LISTED PELLET VENT FOR USE WITH SOLID FUEL OR TO A LINED CHIMNEY CONFORMING TO NATIONAL AND LOCAL BUILDING CODES.**
- **DO NOT CONNECT THIS STOVE TO ANY OTHER EXISTING VENTING SYSTEM SERVING ANOTHER APPLIANCE.**

- **DO NOT CONNECT TO OR USE IN CONJUNCTION WITH ANY AIR DISTRIBUTION DUCTWORK.**
- **THE VENTING SYSTEM MUST BE COMPLETELY AIRTIGHT AND PROPERLY INSTALLED. ALL VENT CONNECTOR JOINTS MUST BE SEALED AND FASTENED IN ACCORDANCE WITH THE PELLET VENT MANUFACTURER'S INSTRUCTIONS TO ENSURE CONSISTENT PERFORMANCE AND AVOID SMOKE AND ASH SPILLAGE.**
- **THE VENTING SYSTEM SHOULD BE CHECKED, AT LEAST TWICE A YEAR FOR ANY BUILDUP OF SOOT OR CREOSOTE.**
- **NEVER BLOCK ANY LOUVERS OF THE STOVE.**
- **IF REQUIRED, A FRESH AIR KIT CAN BE INSTALLED TO SUPPLY COMBUSTION AIR TO THE ROOM OR SPACE (see Appendix F: *Combustion Air Supply*).**
- **MIXING OF APPLIANCE COMPONENTS FROM DIFFERENT SOURCES OR MODIFYING COMPONENTS IS PROHIBITED AND WILL VOID THE WARRANTY.**
- **ANY MODIFICATION OF THE STOVE THAT HAS NOT BEEN APPROVED IN WRITING BY THE TESTING AUTHORITY IS PROHIBITED AND VIOLATES CSA B365 (CANADA), AND ANSI NFPA 211 (USA).**
- **STOVE BUILDER INTERNATIONAL INC. (SBI) GRANTS NO WARRANTY, IMPLIED OR STATED, FOR THE POOR INSTALLATION OR LACK OF MAINTENANCE OF YOUR STOVE AND ASSUMES NO RESPONSIBILITY OF ANY CONSEQUENTIAL DAMAGES.**

## 2.2 Regulations Covering Pellet Stove Installation

When installed and operated as described in these instructions, this pellet stove is suitable for use as a freestanding heater in residential installations.

In Canada, the CSA B365 Installation Code for Solid Fuel Burning Appliances and Equipment and the CSA C22.1 Canadian National Electrical Code are to be followed in the absence of local code requirements. In the USA, the ANSI NFPA 211 Standard for Chimneys, Fireplaces, Vents and Solid Fuel-Burning Appliances and the ANSI NFPA 70 National Electrical Code are to be followed in the absence of local code requirements.

This stove must be connected to a pellet vent system complying with the requirements for Pellet Vent in the standards UL 103, ULC S629M, ULC S609 and UL 641 or to a code-approved masonry chimney with a stainless steel flue liner.

## 2.3 Before Operating Your Stove

Some minor installation and adjustment are required prior to use:

- If desired, LCD sliding support can be installed on the left at the back of the stove; (see **Appendix B: LCD Sliding Bracket Mounting**).
- The handle and door must be adjusted; (see **section 8.1.9 Door Adjustment**)
- The stove must be leveled using threaded legs;
- The decorative panels must be installed; (Refer to decorative panels instruction sheet)
- The door overlay must be installed on the door frame as shown:
- Position the overlay on the door frame and fix it in place from behind using the 4 screws.

**Note:** It is not necessary to remove the glass or any other component to install the overlay.

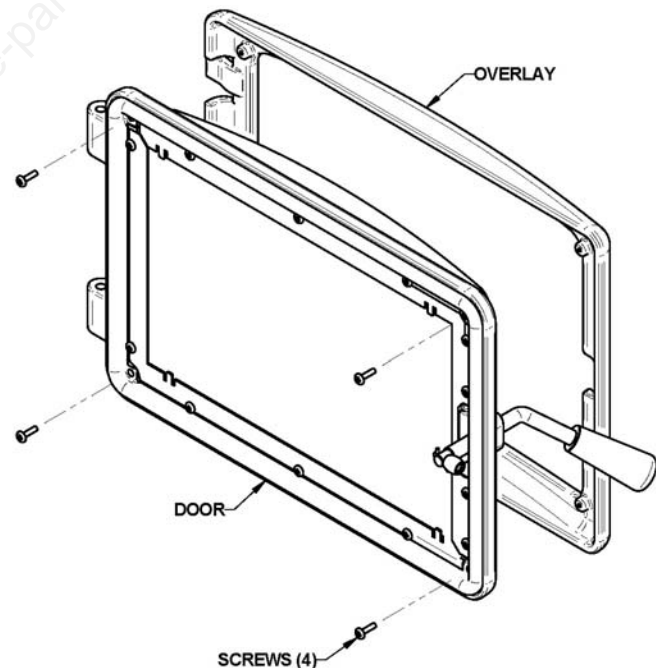

- Make sure the fresh air intake back draft shutter works freely.

### 3 CLEARANCES TO COMBUSTIBLE MATERIAL

The clearances shown in this section have been determined by test according to procedures set out in safety standards ULC S627 (Canada), ASTM E1509 (U.S.A). When the pellet stove is installed so that its surfaces are at, or beyond, the minimum clearances specified, combustible surfaces will not overheat under normal and even abnormal operating conditions.

**WARNING: NO PART OF THE STOVE MAY BE LOCATED CLOSER TO COMBUSTIBLES THAN THE MINIMUM CLEARANCES SPECIFIED ON THE CERTIFICATION LABEL.**

**CAUTION: NO PART OF THE PELLET VENT SYSTEM MAY BE LOCATED CLOSER TO COMBUSTIBLES THAN THE MINIMUM CLEARANCES SPECIFIED BY THE VENT MANUFACTURER.**

**CAUTION: DO NOT USE MAKESHIFT MATERIALS OR MAKE ANY COMPROMISES WHEN INSTALLING THIS STOVE.**

#### 3.1 Location of the Certification Label

Since the information given on the certification label affixed to the stove always overrides the information published in any other media (owner's manual, catalogues, flyers, magazines and/or web sites), it is important to refer to it in order to have a safe and compliant installation. In addition, you will find important information about your stove (model, serial number, etc.). You can find the certification label on the inner side of the hopper lid of the stove.

#### 3.2 Minimum Clearances to Combustibles

LETTER	CLEARANCES TO COMBUSTIBLES	
	CANADA	USA
A*	3" (76 mm)	3" (76 mm)
B	4" (102 mm)	4" (102 mm)
C	3" (76 mm)	3" (76 mm)
D	Refer to vent manufacturer's clearances	Refer to vent manufacturer's clearances
I	60" (1 525 mm)	60" (1 525 mm)

**Note: We recommend leaving 24" on each side of the stove and 12" at the back of the stove in order to facilitate access for maintenance.**

\* From the fresh air intake

### 3.3 Back Wall Installation

For a back wall installation, in order to allow the LCD sliding support to move freely and fully extend, you should allow a minimum of 4" (105 mm) clearance from the side wall (B) and 3" (80 mm) clearance at the back of the stove, from the fresh air intake (A). However, if you wish to install the stove with minimum clearances (see table in **Section 3.2 Minimum Clearances to Combustibles**), it is possible to locate the LCD touch screen elsewhere but within the maximum length of the Telco wire provided. You could also want to install the LCD sliding support on the left side of the stove (see **Appendix B: LCD Sliding Bracket Mounting**).

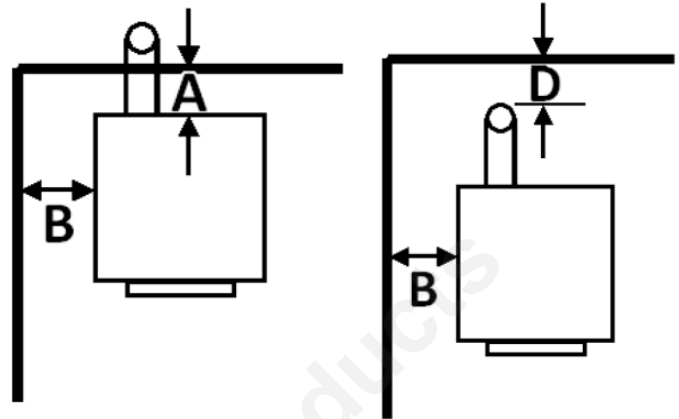

### 3.4 Corner Installation

For a corner installation, in order to allow the LCD sliding support to move freely and fully extend, you should allow a minimum of 6¼" (160 mm) clearance to the adjacent walls (C). However, if you wish to install the stove with minimum clearances (see table in **Section 3.2 Minimum Clearances to Combustibles**), it is possible to locate the LCD touch screen elsewhere but within the maximum length of the Telco wire provided. You could also want to install the LCD sliding support on the left side of the stove (see **Appendix B: LCD Sliding Bracket Mounting**).

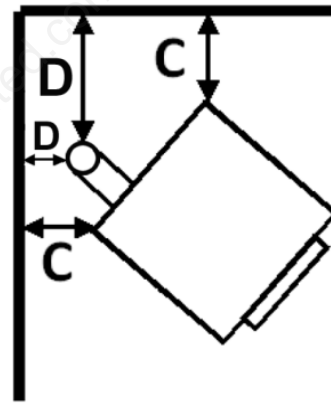

### 3.5 Ceiling Clearances

For ceiling clearances refer to the table in **Section 3.2 Minimum Clearances to Combustibles**.

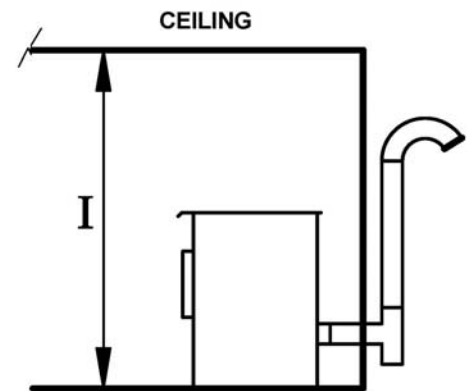

### 3.6 Floor Protection

For floor protection clearances refer to the following table:

	FLOOR PROTECTION	
LETTER	CANADA	USA
E	18" (460 mm)	6" (155 mm)
F	N/A (USA only)	6" (155 mm)
G	8" (205 mm)	N/A (Canada only)
H	8" (205 mm)	N/A (Canada only)

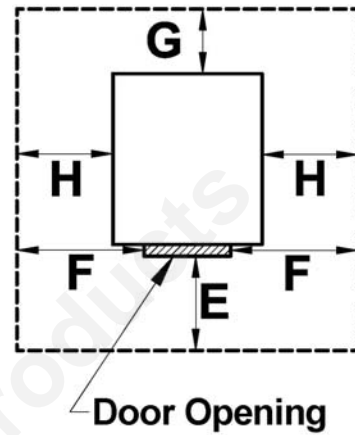

**CAUTION:** THE STOVE MUST BE PLACED ON A CONTINUOUS (GROUTED JOINTS) NONCOMBUSTIBLE MATERIAL SUCH AS CERAMIC TILE\*, CEMENT BOARD, BRICK, MILLBOARD OR EQUIVALENT, OR ANY OTHER APPROVED OR LISTED MATERIAL SUITED FOR FLOOR PROTECTION.

*\*Any type of tile will require a continuous non combustible sheet beneath to prevent the possibility of embers falling through to the combustible floor if cracks or separation should occur in the finished surface, this would include floor protection for built-in raised hearths. Check local codes for approved alternatives.*

## 4 VENTING SYSTEM

### 4.1 General

Even though the chimney draft is mechanical, a suitable venting system will ensure a natural draft which will prevent smoke spillage in your home if a power outage occurs. Moreover, a suitable venting system configuration will help getting the best efficiency out of your stove when installed in accordance with the required EVL (see **Section 4.3 Equivalent Vent Length (EVL)**).

Even the best stove will not function safely and efficiently as intended if it is not connected to a suitable venting system.

### 4.2 Recommendations

In Canada, we recommend that you use a listed pellet vent that meets the ULC S-609-M89/ORD C441-M90 Standard. A pellet vent listed to ULC S629M is also suitable for installation with this stove.

For the United States, we recommend that you use a listed pellet vent that meets the UL-641 Standard. A pellet vent listed to ULC 103 is also suitable for installation with this stove.

This stove can be vented in an existing factory-built or masonry chimney with the addition of a stainless steel liner, provided the chimney is more than 4" in diameter. The liner should be listed and should meet the ULC S-635/640 standard in Canada and the UL-1777 standard in the USA. Refer to the instructions provided by the vent manufacturer, especially when passing through a wall, ceiling or roof.

### 4.3 Equivalent Vent Length (EVL)

Recommended venting system inner pipe diameter is 3". Use a 4" pipe if you have more than 15 feet of Equivalent Vent Length (EVL)

To calculate the EVL of your installation, use the following conversions:

Qty	Type of pipe	EVL equivalent(ft)
1	90° elbow or "T"	5
1	45° elbow	3
1 ft	Horizontal pipe run	1
1 ft	Vertical pipe run	0.5

**NOTE:** Horizontal pipe runs shall not exceed 9 feet.

**NOTE:** Never exceed 30 feet of EVL.

**NOTE:** If the stove is located at an altitude of 3,000 feet or more, it is recommended to use a 4" venting system inner diameter if the ELV is 7 feet or more.

Here is an example to help you calculate Equivalent Vent Length. On the following figure the EVL can be calculated like this:

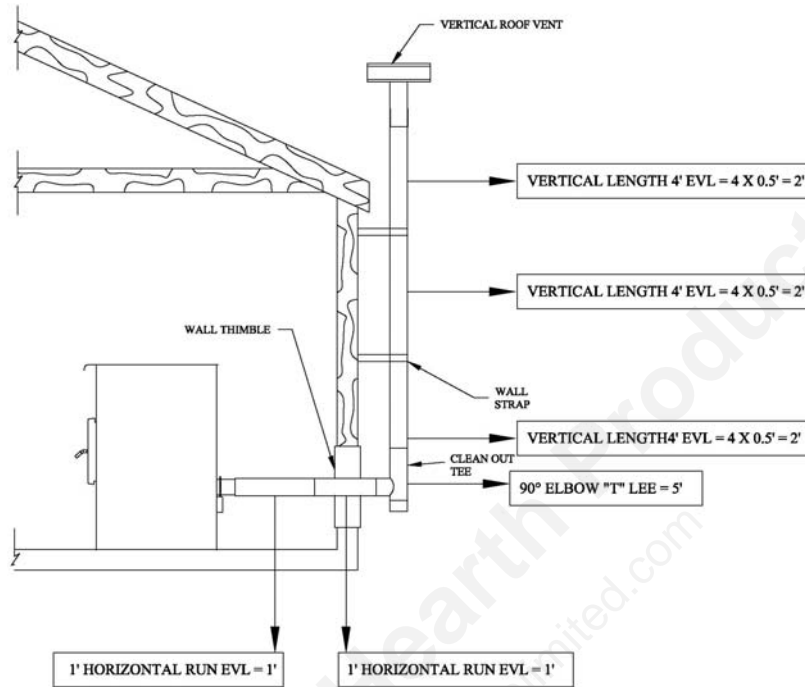

- 2 horizontal run of 1' =  $(2 \times 1') \times 1' = 2'$  of EVL
- 1 elbow 90° or "Tee" = 5' of EVL
- 3 vertical length of 4' =  $(3 \times 4') \times 0.5' = 6'$  of EVL
- Total EVL =  $(2' + 5' + 6') = 13'$ .

EVL is less than 15' therefore it is correct to use a 3" pipe.

**NOTE:** Do not include the exterior wall termination in the EVL calculation. (45° elbow and termination)

#### 4.4 Termination Location

Termination should not be located so that hot exhaust gases can be a hazard. They can reach temperatures of 500°F and cause serious burns.

**CAUTION:** TERMINATION COLLAR (SPARK ARRESTER) IS MANDATORY.

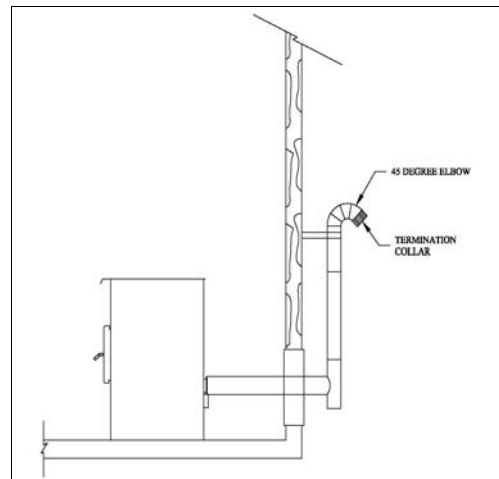

#### 4.4.1 Permitted Termination Location

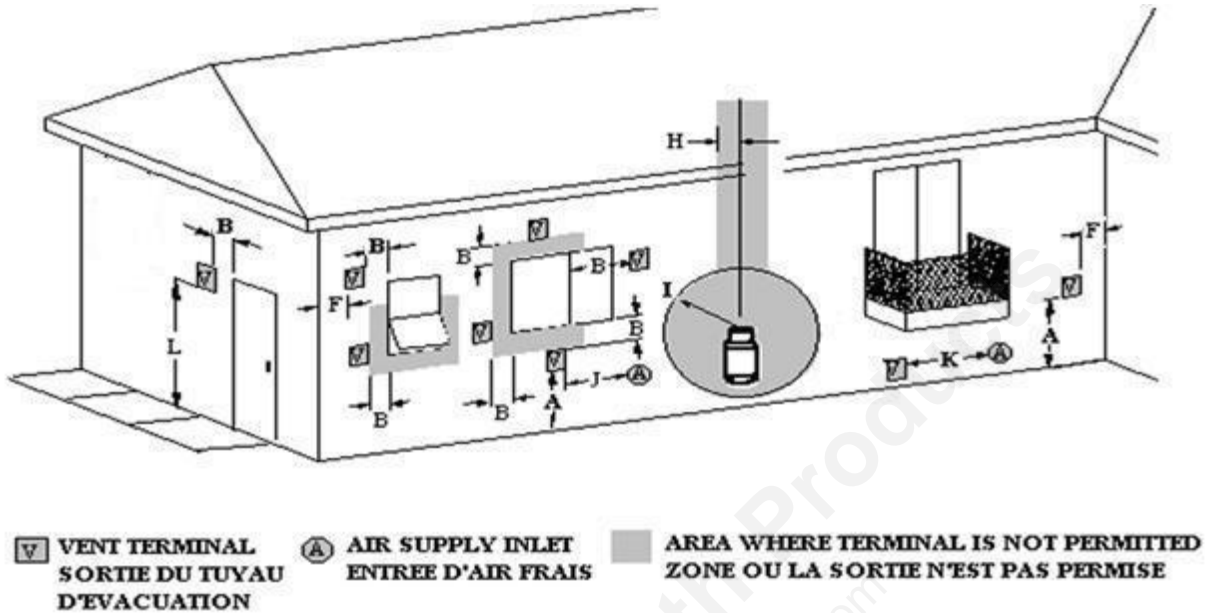

#### Canada:

Letter	Min. clearances	Description
A	12" (30 cm)	Clearances above grade, veranda, porch, deck, or balcony
B	36" (91 cm)	Clearance to window or door that may be opened
F	0" (0 cm)	Clearance to outside corner
H	36" (91 cm)	Not to be installed above a meter/regulator assembly within 36" (91 cm) horizontally from the vertical center-line of the regulator and for 15' vertically
I	72" (183 cm)	Clearance to gas service regulator vent outlet or within 36" (91 cm) of an oil tank vent or an oil tank fill inlet
J	36" (91 cm)	Clearance to non-mechanical air supply inlet to building or the combustion air inlet to any other stove
K	72" (183 cm)	Clearance to a mechanical air supply inlet
L	84" (213 cm)	Clearance above paved side-walk or a paved driveway located on public property
	36" (91 cm)	Clearance to property boundary

**United States:**

- Not Less than 36" (91 cm) above any forced air inlet located within 120" feet (305 cm);
- Not Less than 48" (122 cm) below or horizontally from, or one foot (30 cm) above, any door, window or gravity air inlet into any building;
- Not Less than 24" (61 cm) from an adjacent building and not less than 84" (213 cm) above grade when located adjacent to a public walkway.
- Other restrictions may apply, such as the need to maintain a minimum distance to a gas meter. See NFPA 211 for further information.

## **4.5 Installation Configurations**

### **4.5.1 Installation Warnings, Cautions and Recommendations Reminder**

- **PROFESSIONAL INSTALLATION IS HIGHLY RECOMMENDED**
- **THIS STOVE USES A PRESSURIZED VENTING SYSTEM. ALL VENT CONNECTOR JOINTS MUST BE SEALED AND FASTENED. CONSULT THE PELLET VENT MANUFACTURER'S INSTRUCTION TO ENSURE PROPER INSTALLATION, CONSISTENT PERFORMANCE, AND TO AVOID SMOKE AND ASH SPILLAGE.**
- **USE RTV, METALLIC TAPE, AND A MINIMUM OF THREE SELF-TAPING SCREWS AT ALL JOINT CONNECTIONS TO ENSURE A TIGHT SEAL.**
- **THE CHIMNEY CONNECTOR SHALL NOT PASS THROUGH AN ATTIC OR ROOF SPACE, CLOSET OR SIMILAR CONCEALED SPACE OR FLOORS OR CEILING.**
- **DO NOT INSTALL A FLUE DAMPER IN THE VENTING SYSTEM OF THIS STOVE.**
- **INSTALL VENTING SYSTEM AT CLEARANCES SPECIFIED BY THE VENT MANUFACTURER.**
- **THE USE OF A SPARK ARRESTER AT THE END OF THE TERMINATION IS MANDATORY.**

#### 4.5.2 Through Wall Installation (Main Floor or Basement)

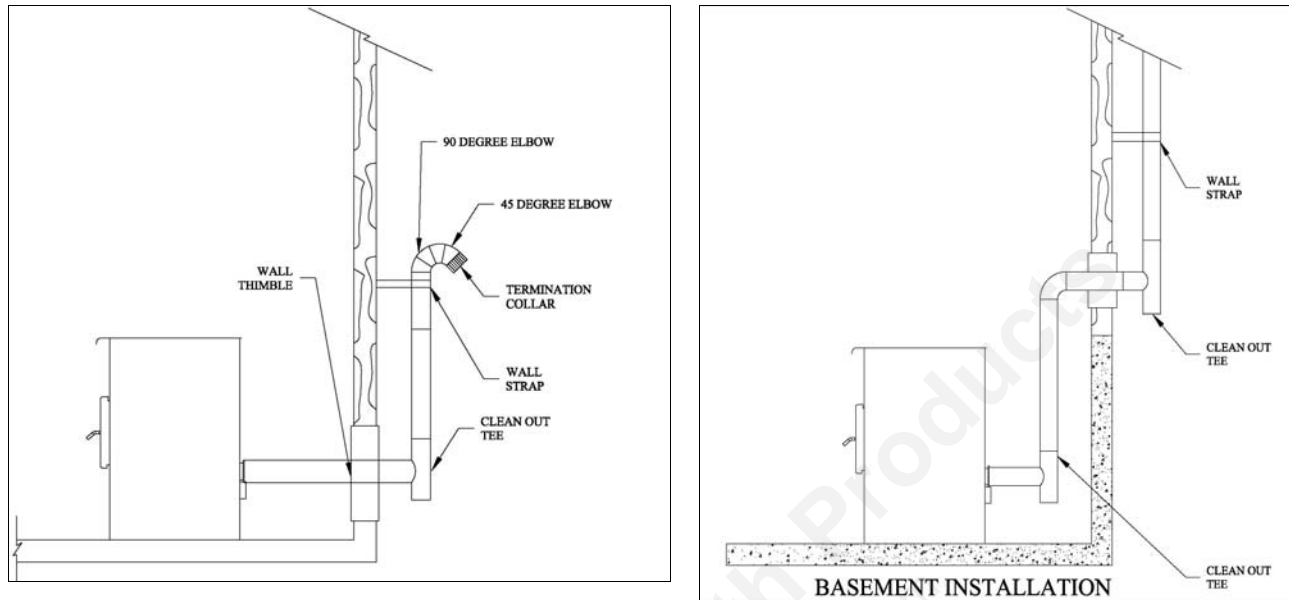

1. Position stove following clearances given in **Section 3, Clearances to Combustible Material** and following vent manufacturer's instructions. Then locate the position of the exhaust pipe in the wall.
2. Install wall thimble as per vent manufacturer's instructions.
3. Attach enough piping length to go through the wall thimble and extend at least 6 inches beyond the exterior wall.
4. Attach cap and seal outside wall thimbles with high temperature waterproof silicone sealant.

**CAUTION:** TO REDUCE THE RISK OF SMOKE SPILLAGE THERE SHOULD ALWAYS BE AT LEAST ONE FOOT OF VERTICAL RISE FOR EACH FOOT OF HORIZONTAL RUN. IN ALL CASES, AT LEAST 3 FEET OF VERTICAL RISE IS NEEDED.

**WARNING:** TERMINATION SHOULD NOT BE LOCATED SO THAT HOT EXHAUST GASES CAN BE A HAZARD. EXHAUST GASES CAN REACH TEMPERATURES OF 500°F AND CAUSE SERIOUS BURNS. SEE SECTION 4.4.1 PERMITTED TERMINATION LOCATION

### 4.5.3 Through Roof Installation

1. Position stove following clearances given in **Section 3.2 Minimum Clearances to Combustibles** and following vent manufacturer's instructions.
2. Install a cleanout tee to the stove exhaust. If necessary, use a horizontal additional length between the exhaust and the tee. If you wish to center the vertical part of the vent with the stove, a 45° elbow and a tee can be used to route the pipe from the exhaust towards the back center of the stove.
3. Drop the plumb bob over the center of the tee outlet and mark location on the ceiling. Install the ceiling support and the vent pipe by following the vent manufacturer's instructions.
4. Always follow vent manufacturer's clearances instructions from combustible materials. When passing through additional floors or ceilings, always install a fire stop spacer.
5. After lining up for hole in roof, cut either a round or square hole in roof. Install upper edge and sides of flashing under roofing materials. Nail it to the roof along upper edge. Do not nail lower edge. Seal nail heads with flexible waterproof sealant.
6. Apply high temperature waterproof silicone sealant where the storm collar meets the vent. Slide storm collar down until it sits on the flashing.
7. Seal and install vertical roof vent. If required, seal and install a storm collar.

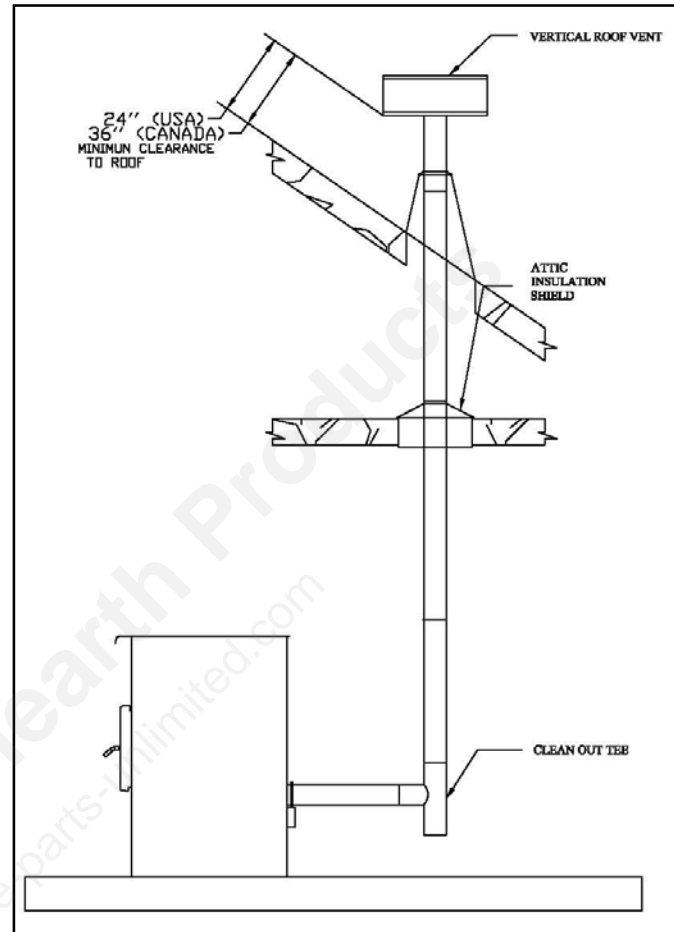

#### 4.5.4 Through a Prefabricated Chimney

The best method to make an installation through a prefabricated chimney is to run a 3" stainless steel liner inside the prefabricated chimney (or a 4" stainless steel liner depending on the Equivalent Vent Length calculated in **Section 4.3 Equivalent Vent Length (EVL)**).

1. Position stove following clearances given in **Section 3.2 Minimum Clearances to Combustibles** and following vent manufacturer's instructions.
2. Install a cleanout tee to the stove exhaust. If necessary, use a horizontal additional length between the exhaust and the tee. If you wish to center the vertical part of the vent with the stove, a 45° elbow and a tee can be used to route the pipe from the exhaust towards the back center of the stove.
3. Connect the pellet vent to the stainless steel liner according to the vent manufacturer's instructions.
4. Seal and install vertical roof vent. If required, seal and install a storm collar.

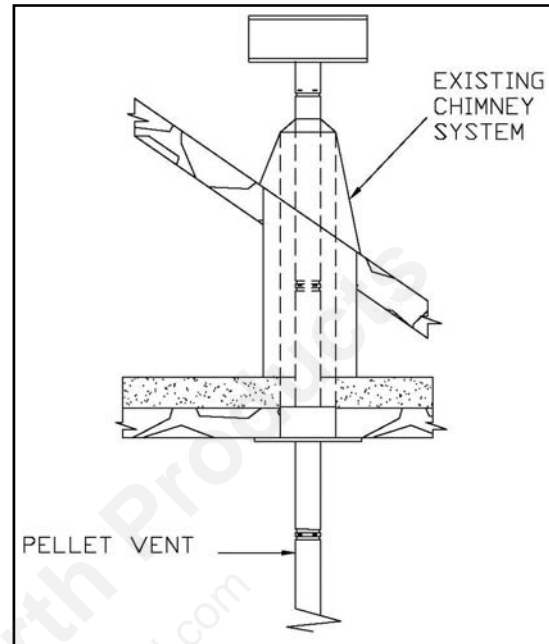

**WARNING:** IN THE U.S., THE USE OF A STAINLESS STEEL LINER IS MANDATORY. IN CANADA, IT IS NOT MANDATORY BUT IS STRONGLY RECOMMENDED.

**NOTE:** VENTING DIRECTLY IN AN OVERSIZED CHIMNEY AND OMIT THE USE OF A STAINLESS STEEL LINER CAN AFFECT CHIMNEY DRAFT AND DECREASE STOVE PERFORMANCES.

#### 4.5.5 Through an Existing Masonry Fireplace

1. Position stove, following clearances shown in **Section 3.2 Minimum Clearances to Combustibles** and following vent manufacturer's instructions.
2. Build and Install a blocking plate inside the chimney to seal the fireplace damper. Stainless steel plate and screws are recommended. Cut a hole for the exhaust pipe. If needed, cut a second hole for the air intake pipe (see **Appendix F: Combustion Air Supply**).
3. Attach a section of pipe and clean out tee to the exhaust, making sure the clean out tee is centered in the chimney flue area.
4. Build and install flashing above the fireplace. Stainless steel plate and screws are recommended. Cut a hole for the vent pipe. If needed, cut a second hole for the air intake pipe. Seal all joints with high temperature waterproof silicone sealant to prevent water leakage.
5. Seal and install vertical roof vent. If required, seal and install a storm collar.

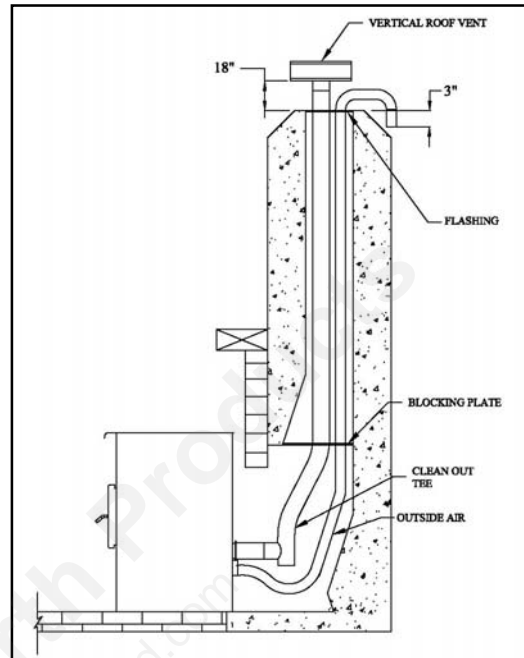

**NOTE: THE STRUCTURAL CONDITION OF THE MASONRY CHIMNEY MUST FIRST BE INSPECTED BY A QUALIFIED CHIMNEY SWEEP OR INSTALLER.**

**NOTE: YOU WILL NEED A PIPE LENGTH EQUAL TO THE CHIMNEY HEIGHT FROM THE HEARTH. IF OUTSIDE COMBUSTION AIR IS TO BE USED, YOU WILL NEED A PIPE LENGTH EQUAL TO THE CHIMNEY HEIGHT PLUS 18 INCHES.**

#### 4.5.6 Through an Existing Masonry Chimney

1. Position stove following clearances shown in **Section 3.2 Minimum Clearances to Combustibles** and following vent manufacturer's instructions.
2. Mark the center of the hole where the vent pipe will go through the masonry chimney.
3. It is necessary to make a hole in the masonry with a diameter of 4 " around the mark for a 3" pipe. For a 4" pipe, a hole of 5" in diameter.
4. Build and install flashing above the chimney. Stainless steel plate and screws are recommended. Cut a hole for the vent pipe. If needed, cut a second hole for the air intake pipe. Seal all joints with high temperature waterproof silicone sealant to prevent water leakage.
5. Install the cleanout tee at the bottom of the vertical vent system and lower it down the chimney until the center branch of the tee is aligned with the hole in the masonry.
6. Install and seal flashing with high temperature waterproof silicone sealant.
7. Seal and install vertical roof vent. If required, seal and install a storm collar.
8. Connect the horizontal vent pipe to the cleanout tee by pushing it through the hole in the masonry.
9. If desired, once the horizontal pipe is in place, the space between the pipe and masonry may be filled with high-temperature grout.
10. If desired, install a trim collar and use an additional horizontal vent pipe length, if required, to connect the stove to the chimney.

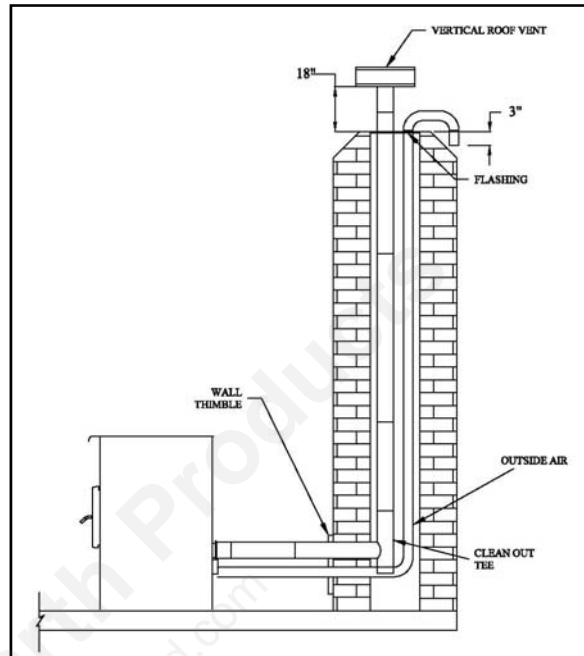

## **PART B - OPERATION**

### **5 GENERAL INFORMATION**

#### **5.1 Operation Warnings, Cautions and Recommendations**

- **KEEP THIS MANUAL FOR REFERENCE.**
- **IT IS HIGHLY RECOMMENDED THAT THE USER BUYS THIS PRODUCT FROM A RETAILER WHO CAN PROVIDE INSTALLATION AND MAINTENANCE ADVICES.**
- **DURING THE FIRST FEW FIRES, YOUR STOVE WILL EMIT AN ODOR AND A SMALL AMOUNT OF FUMES AS THE HIGH TEMPERATURE PAINT CURES OR BECOMES SEASONED TO THE METAL. MAINTAINING SMALLER FIRES WILL MINIMIZE THIS. AVOID PLACING ITEMS ON STOVETOP DURING THIS PERIOD TO AVOID DAMAGING THE PAINT SURFACE. MAKE SURE THE ROOM IS WELL-VENTILATED. OPEN WINDOWS. ODORS AND FUMES RELEASED DURING THIS PROCESS ARE UNPLEASANT BUT THEY ARE NOT TOXIC. ONCE YOU HAVE BURNED THE FIRST 40LBS OF PELLETS, IT IS RECOMMENDED TO INSPECT THE STOVE AND THE VENTING SYSTEM TO MAKE SURE THAT THERE IS NO LEAKS.**
- **HOT WHILE IN OPERATION, KEEP CHILDREN, CLOTHING AND FURNITURE AWAY. CONTACT MAY CAUSE SKIN BURNS. GLOVES MAY BE NEEDED FOR STOVE OPERATION.**
- **THIS STOVE MUST SERVE AS A SUPPLEMENTARY HEAT SOURCE. AN ALTERNATIVE HEAT SOURCE SHOULD BE AVAILABLE IN THE HOME IF NEEDED. THE MANUFACTURER CANNOT BE HELD RESPONSIBLE FOR ADDITIONAL HEATING COSTS ASSOCIATED WITH THE USE OF AN ALTERNATIVE HEAT SOURCE.**
- **USING A STOVE WITH CRACKED OR BROKEN COMPONENTS, SUCH AS GLASS OR BAFFLE MAY PRODUCE AN UNSAFE CONDITION AND MAY DAMAGE THE STOVE.**
- **NEVER USE GASOLINE, GASOLINE-TYPE LANTERN FUEL (NAPHTHA), FUEL OIL, MOTOR OIL, KEROSENE, CHARCOAL LIGHTER FLUID, OR SIMILAR LIQUIDS OR AEROSOLS. KEEP ALL SUCH LIQUIDS OR AEROSOLS WELL AWAY FROM THE STOVE WHILE IT IS IN USE.**
- **DO NOT STORE FUEL WITHIN STOVE MINIMUM CLEARANCES TO COMBUSTIBLE.**
- **THIS STOVE SHOULD BE MAINTAINED AND OPERATED AT ALL TIMES IN ACCORDANCE WITH THESE INSTRUCTIONS. NOT FOLLOWING THE INSTRUCTIONS OF THIS MANUAL MAY CAUSE SMOKE SPILLAGE AND OTHER POTENTIAL HAZARDS. IT IS ALWAYS RECOMMENDED TO INSTALL SMOKE DETECTORS AND FIRE EXTINGUISHER IN A CONVENIENT LOCATION.**
- **THE VIEWING DOOR MUST BE CLOSED AND LATCHED DURING OPERATION. ASH DRAWER ACCESS PANEL MUST ALSO BE CLOSED DURING OPERATION.**

- **NEVER TRY TO REPAIR OR REPLACE ANY PART OF THE STOVE UNLESS INSTRUCTIONS ARE GIVEN BY THE MANUFACTURER. ALL OTHER WORK SHOULD BE DONE BY A TRAINED TECHNICIAN.**
- **DO NOT OPERATE THE STOVE IF THE FLAME BECOMES DARK AND SOOTY OR IF THE BURN POT OVERFILLS WITH PELLETS. TURN THE STOVE OFF, INSPECT IT, AND CALL YOUR DEALER.**
- **TURNING THE STOVE OFF DOES NOT DISCONNECT ALL POWER FROM THE STOVE. DISCONNECT THE POWER CORD BEFORE PERFORMING ANY MAINTENANCE OR REPAIRS ON THE STOVE.**
- **ALLOW THE STOVE TO COOL BEFORE CARRYING OUT ANY MAINTENANCE OR CLEANING. ASHES SHOULD BE PLACED IN A METAL CONTAINER WITH A TIGHT FITTING LID. THE CLOSED METAL CONTAINER SHOULD BE PLACED ON A NONCOMBUSTIBLE FLOOR OR ON THE GROUND, WELL AWAY FROM ALL COMBUSTIBLE MATERIALS, PENDING FINAL DISPOSAL. IF THE ASHES ARE DISPOSED OF BY BURIAL IN SOIL OR OTHERWISE LOCALLY DISPERSED, THEY SHOULD BE RETAINED IN THE CLOSED CONTAINER UNTIL ALL ASHES HAVE BEEN THOROUGHLY COOLED.**
- **DO NOT OPERATE THE STOVE IF YOU SMELL OR SEE SMOKE. TURN IT OFF, MONITOR IT AND CALL YOUR DEALER IF NECESSARY. DO NOT UNPLUG IT. NEVER OPEN THE DOOR.**
- **IT IS RECOMMENDED TO UNPLUG THE STOVE WHEN IT'S NOT IN USE FOR PROLONGED AMOUNT OF TIME (I.E. DURING SUMMER). SENSORS ON THE STOVE ARE ACTIVATED BY HEAT AND COULD ACTIVATE THE FANS EVEN IF THE STOVE IS NOT IN FUNCTION.**
- **THIS STOVE REQUIRES REGULAR MAINTENANCE AND CLEANING. FAILURE TO FOLLOW THE MAINTENANCE SCHEDULE (SEE SECTION 8.1.1 RECOMMENDED MAINTENANCE SCHEDULE) WILL REDUCE THE STOVE PERFORMANCE AND COULD EVENTUALLY DAMAGE IT. IT MAY ALSO LEAD TO SMOKE SPILLAGE IN YOUR HOME.**
- **THIS STOVE IS DESIGNED AND TESTED SPECIFICALLY FOR USE ONLY WITH FOUR DIFFERENT TYPES OF PELLETS: STANDARD WOOD PELLETS, 100% BARK PELLETS, SAWDUST / HAY MIX PELLETS AND SWITCH GRASS PELLETS. ANY OTHER TYPE OF FUEL BURNED IN THIS HEATER WILL VOID THE WARRANTY AND SAFETY LISTING.**
- **HOPPER SHOULD ONLY CONTAIN PELLETS. HOPPER SHOULD BE KEPT FREE OF ANY FOREIGN OBJECTS AT ALL TIME TO PREVENT ANY DAMAGE THE STOVE.**
- **THE STOVE WILL NOT OPERATE DURING A POWER OUTAGE. IF AN OUTAGE DOES OCCUR, CHECK THE STOVE FOR SMOKE SPILLAGE. OPENING A WINDOW WILL PREVENT NEGATIVE PRESSURE AND SMOKE SPILLAGE IN THE ROOM.**
- **DO NOT UNPLUG THE STOVE IF YOU SUSPECT IT IS MALFUNCTIONING. TURN IT OFF, MONITOR IT AND CALL YOUR DEALER IF NECESSARY.**

- THIS STOVE IS DESIGNED TO PROVIDE THE OPTIMUM PROPORTIONS OF FUEL AND AIR TO THE FIRE IN ORDER TO BURN FREE OF SMOKE AND SOOT. ANY BLOCKAGE OF THE AIR SUPPLY TO OR FROM THE STOVE WILL SERIOUSLY DECREASE ITS PERFORMANCE AND WILL BE EVIDENT BY A SMOKING EXHAUST, A SOOT BUILDUP ON THE WINDOW AND ON OUTSIDE WALLS. FOR BEST OPERATION, THE ASH CONTENT OF THE PELLET FUEL SHOULD BE LESS THAN 1% AND THE CALORIFIC VALUE APPROXIMATELY 8,200 BTU/LB. OTHERS FUELS WITH A HIGH ASH CONTENT WILL REQUIRE A HIGHER LEVEL OF MAINTENANCE AND CLEANING.
- THE STOVE WILL NOT OPERATE USING NATURAL DRAFT OR WITHOUT A POWER SOURCE TO ACTIVATE THE BLOWER SYSTEMS AND FUEL FEED SYSTEM.
- STOVE BUILDER INTERNATIONAL INC. GRANTS NO WARRANTY, IMPLIED OR STATED, FOR BAD INSTALLATION OR LACK OF MAINTENANCE OF YOUR STOVE, AND ASSUMES NO RESPONSIBILITY OF ANY CONSEQUENTIAL DAMAGES.
- IF YOU NOTICE A SMOLDERING FIRE (BURNPOT FULL BUT NO VISIBLE FLAME) AND A HEAVY SMOKE BUILDUP IN FIREBOX, IMMEDIATELY TURN OFF THE STOVE, BUT DO NOT UNPLUG IT. DO NOT OPEN THE DOOR. MAKE SURE THAT THE FRESH AIR INTAKE SHUTTER WORKS FREELY. WAIT UNTIL SMOKE INSIDE THE FIREBOX CLEARS AND BLOWERS SHUT DOWN. DO AS INSTRUCTED IN "EVERYDAY STARTUP" THEN ATTEMPT TO RESTART THE STOVE. IF THE PROBLEM PERSISTS, CONTACT YOUR DEALER. NOTE THAT SMOKE BUILD-UP DURING IGNITION MAY OCCUR. SMOKE CAN ACCUMULATE IN THE FIREBOX FOR A FEW SECONDS JUST BEFORE THE IGNITOR IS HOT ENOUGH TO FIRE-UP THE PELLETS IN THE BURN POT. THIS IS NORMAL. AS SOON AS THERE IS FIRE IN THE BURN POT, SMOKE WILL DISAPPEAR.
- MAINTAIN PROPER VENTILATION. IT IS IMPORTANT THAT ADEQUATE OXYGEN IS BEING SUPPLIED TO THE FIRE FOR PROPER COMBUSTION. DURING THE WINTER SEASON, MAKE SURE THAT THE FRESH AIR INTAKE IS FREE OF ANY ICE AS THIS WILL STARVE THE FIRE OF AIR AND PREVENT THE PROPER OPERATION OF THE STOVE. MAKE SURE THE FRESH AIR INTAKE BACKDRAFT SHUTTER WORKS FREELY.
- OPERATING YOUR STOVE AT THE MAXIMUM SETTING DURING A LONG PERIOD OF TIME MAY REDUCE THE STOVE AND ITS COMPONENTS LIFE EXPECTANCY.

### **5.1.1 Zone Heating and How to Make It Work for You**

Your new pellet stove is a space heater, which means it is intended to heat the area it is installed in, as well as spaces that connect to that area, although to a lower temperature. This is called zone heating and it is an increasingly popular way to heat homes or spaces within homes.

Zone heating can be used to supplement another heating system by heating a particular space within a home, such as a basement family room or an addition that lacks another heat source.

Although the stove may be able to heat the main living areas of your house to an adequate temperature, this stove must serve as a supplementary heat source. We strongly recommend that you also have a conventional oil, gas or electric additional heating system to provide heating in the home if needed. The manufacturer cannot be responsible for additional heating costs associated with the use of an alternative heat source in case of stove failure or power outage.

Your success with zone heating will depend on several factors: Proper stove size, stove location, heating area, house layout and insulation and your climate zone.

## 5.2 Combustible

### 5.2.1 Proper Fuel

Each type of pellet has its properties and will burn differently. The amount of ashes produced can also vary greatly. Factory-approved pellets are those ¼” or 5/16” in diameter and not over 1” long. Longer or thicker pellets will prevent proper pellet feed.

The bottom-feed system of this stove is designed and tested specifically for use with four different types of pellets: standard wood pellets, 100% bark pellets, sawdust/hay mix pellets and switch grass pellets.

Pellet type	Composition	Ash quantity	Ignition
Wood pellets	Made of hard or soft wood	Small quantity	Easy
Wood and hay pellets	1/3 hay and 2/3 wood. It is important to respect that mix (+/- 10%).	More ashes than straight wood pellets.	Ignition may be more difficult than straight wood pellets.
Bark pellets	100% bark pellets	Produce a hard crust that will be pushed into the ash drawer. Their ash content is very high.	Ignition may be more difficult than straight wood pellets.
Switch grass pellets	100% switch grass	Vary from medium to high content depending on when switch grass is harvested. A light and friable crust will form in front of the burn pot. It should break easily and fall into the ash drawer.	Ignition may be more difficult than straight wood pellets.

**WARNING: BURNING OTHER TYPES OF PELLETS IS PROHIBITED. IT VIOLATES THE BUILDING CODES FOR WHICH THE STOVE HAS BEEN APPROVED AND WILL VOID THE WARRANTY.**

### 5.2.2 Where to Store Bags of Pellets

We recommend that you store your bags of pellets in a dry and well ventilated area if possible. Using dry pellets will increase the performance of your stove. You may want to have a bag or two in the same room as your stove for refueling but make sure to respect the minimum clearances to combustible materials and the space required for refilling and ash removal.

## 6 STOVE CONTROLS

### 6.1 General Information

The stove uses a LCD touch screen, the latest technology in control devices. The blowers and feed system are controlled from this screen.

The LCD touch screen is factory-installed on the right hand side of the stove when facing it. See **Appendix B: LCD Sliding Bracket Mounting** for left hand side installation.



#### 6.1.1 LCD Touch Screen Controls, Operation and Configuration

The LCD control is an electronic visual display as well as a touch screen that will light-up as you touch any location on the display area. The Main Status Page will then display different icons layout depending if manual or thermostat mode is selected.



Manual Mode Main Status Page



Thermostat Mode Main Status Page

**Description of each main status page icon:**



Indicates that the stove is in the manual mode. It will therefore run continuously on the selected setting until it is manually modified, turned OFF or if the stove runs out of pellets (see **Section 6.1.8 Selecting Manual or Thermostat Mode**).

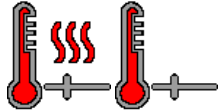

Indicates that the stove is in the thermostat mode. The red waves indicate that the thermostat is calling for heat. The waves will disappear once the thermostat has reached room temperature setting (see **Section 6.1.8 Selecting Manual or Thermostat Mode**).

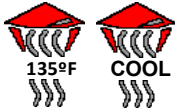

Indicates the exhaust temperature. If temperature is below 115°F, the numeric value will disappear and “COOL” will be displayed.



Selecting the flame icon will bring you to the heat control scroll bar. Moving the cursor to the left will reduce the feed of pellets therefore produce less heat and moving it to the right will increase the feed of pellets which will produce more heat (see **Section 6.1.6 Adjusting the Combustion Level (Heat Output)**).



Indicates that the stove is “Off”.



Indicates that the stove is either “On” in manual mode or calling for heat in thermostat mode.



Indicates that the stove is in thermostat mode, in pilot cycle waiting for heat



calling. Indicates that the stove is in thermostat mode but not calling for heat and pilot cycle is completed.



Selecting the letter icon will display a menu screen where you can access the following pages: Set-up, Trouble shoot, Statistics and Program (see **Section 6.1.2 Configuration and Operation Diagram**).

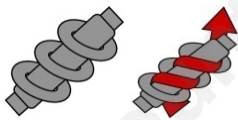

Selecting the grey auger icon will display the auger option menu. Once auger option is selected auger icon will show a red arrow and will blink until the end of the chosen option (see **Section 6.1.10 Filling or Purging Auger Housing**).



The grey fan icon indicates that the convection fan is on default setting. The grey fan icon with red arrows indicates that fan speed default setting has been reduced with the optional fan speed scroll bar (see **Section 6.1.7 Convection Fan Speed Reduction (Optional)**).

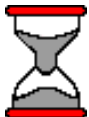

Indicates the selected pilot cycle. Once selected, one of the following cycles, (30min, 45min, 60min, Always On or Always Off) will display under the hourglass icon (see **Section 6.1.9 Selecting The Pilot Cycle**). Default setting is “Always Off”.



Indicates that unusual cycle has been detected. When this occurs, the envelope icon will be displayed in replacement of the convection fan icon. Press on the envelope to read the warning message.

## 6.1.2 Configuration and Operation Diagram

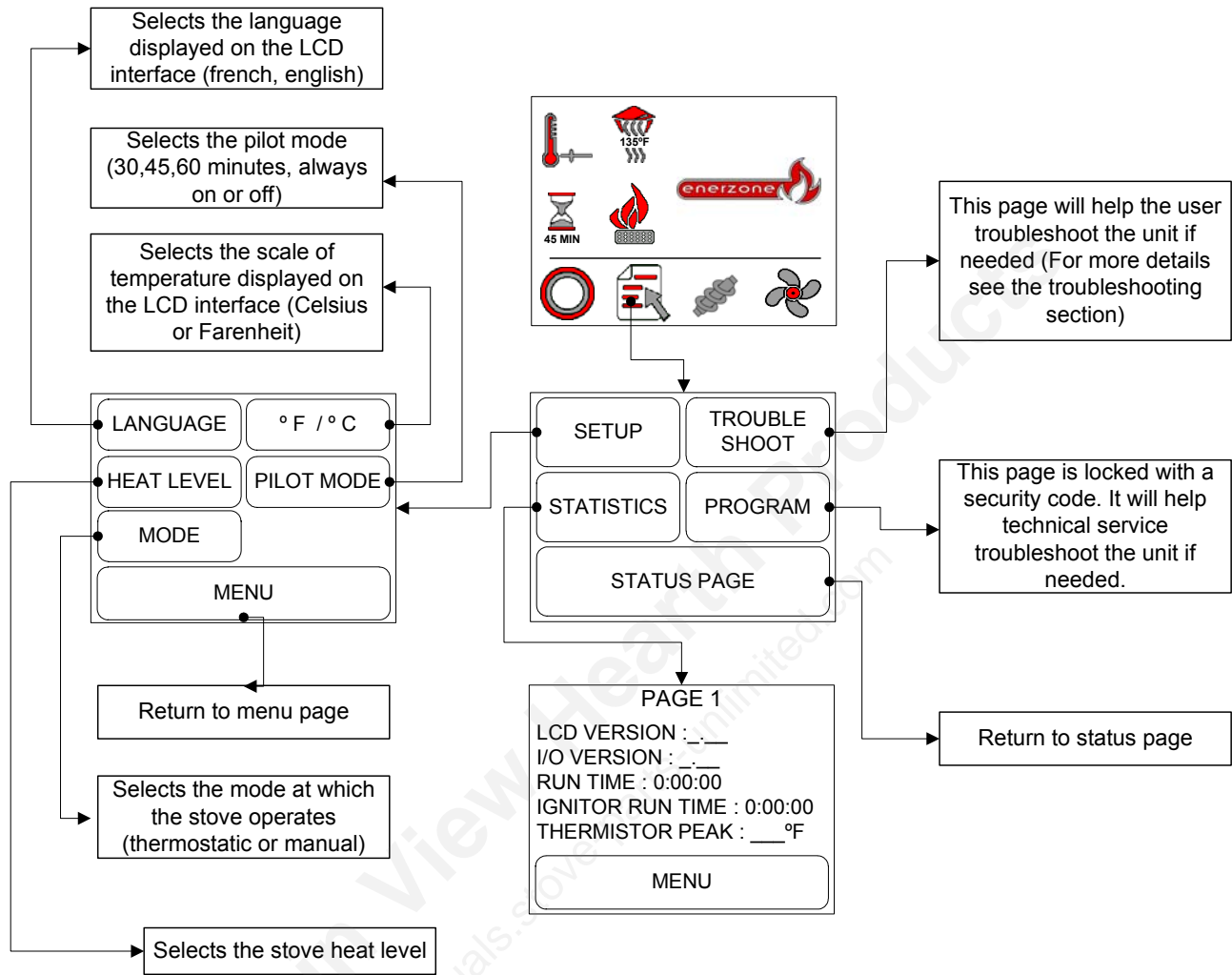

### 6.1.3 Selecting the Language



From the main status page, choose the letter icon . Select “SETUP” and then “LANGUAGE”. You can choose between two languages, English or French.

### 6.1.4 Viewing Statistics



From the main status page, choose the letter icon . Select “SETUP” and then “STATISTICS”. This page will display statistics that can be very useful to a service technician or SBI technical support.

### 6.1.5 Changing Temperature Unit (°F or °C)



From the main status page, choose the letter icon . Select “SETUP” and then “°F / °C”. Select icon °F or °C in order to display temperatures in the desired unit.

## 6.1.6 Adjusting the Combustion Level (Heat Output)

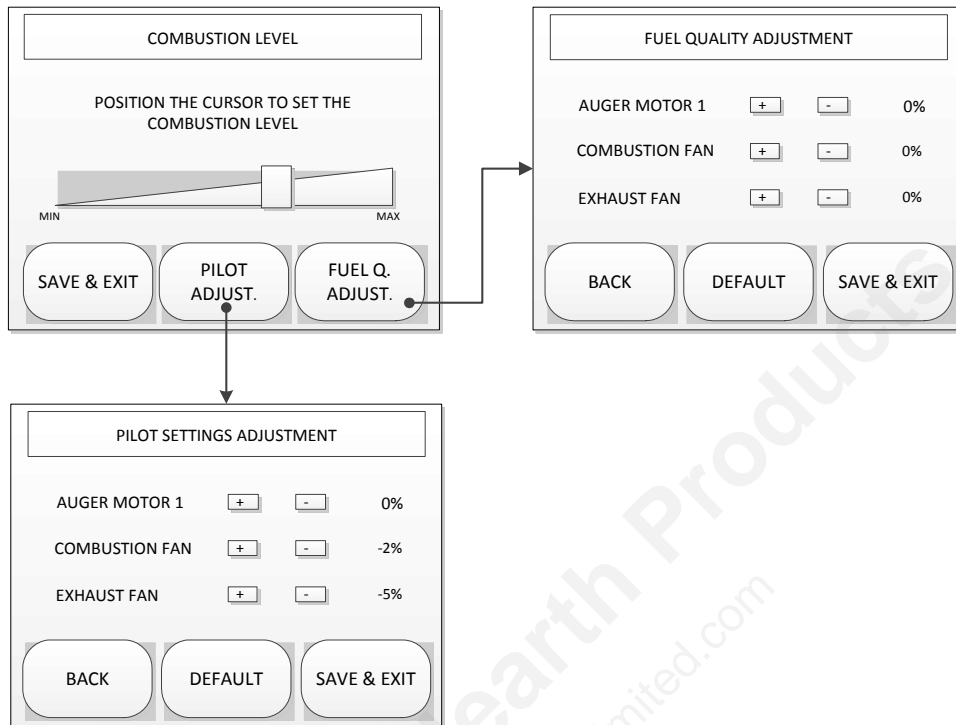

The stove's input range goes from 8,500 BTU to 50,000 BTU. To change combustion level, select

the flame icon  on the main status page to display the combustion level scroll bar. The scroll bar is linearly scaled between the minimum and maximum.

**Note:** Input range may vary according to the type of pellets being used.

Even though your stove can burn a large variety of pellets, we strongly recommend the use of high quality pellets to obtain maximum performance out of your stove (see **Section 5.2.1 Proper Fuel**). When using lower quality combustible, a restrictive venting system or using the stove in high altitude, you may need to adjust the "PILOT SETTING ADJUSTMENT" and the "FUEL QUALITY ADJUSTMENT". These two (2) settings are available from the "COMBUSTION LEVEL" page.

**Note:** To obtain optimal results make sure the venting system, heat exchanger and exhaust channels are cleaned before performing any setting changes.

### 6.1.6.1 PILOT ADJUST. (Pilot Settings Adjustment)

The "PILOT SETTINGS ADJUSTEMENT" will allow you to modify default settings by +/- 5% for auger motor 1 and +/- 10% for exhaust fan, but will only apply during pilot cycle:

To restore default setting, select "DEFAULT".

Refer to following section for settings adjustments explanation.

### 6.1.6.2 FUEL Q. ADJUST (Fuel Quality Adjustment)

The “FUEL QUALITY ADJUSTMENT” will allow you to modify default settings by +/- 5% for auger motor 1 and +/- 10% for combustion and exhaust fan.

To restore default setting, select “DEFAULT”.

Here are some situations where you may want to adjust these components:

#### Average speed of auger motor #1:

You may want to increase the auger motor #1 speed if fire goes out when combustion level is at minimum setting. When burning poor quality pellets you may also need to reduce the auger motor speed to avoid unburned pellets to fall into the ash drawer at any combustion level.

#### Speed of combustion fan:

You may want to reduce combustion fan speed if fire goes out when combustion level is at its minimum setting. You may also want to increase combustion fan speed to avoid unburned pellets to fall into the ash drawer at any combustion level.

#### Speed of exhaust fan:

You may want to reduce exhaust fan speed if natural draft is excessive and/or if the flame is low and almost at the same height at any combustion level. You may also want to increase the exhaust fan speed if vent configuration is too restrictive or flame height tends to be high at any combustion level (see **Appendix C: Flame Characteristics**).

### 6.1.7 Convection Fan Speed Reduction (Optional)



When the grey fan icon is displayed, the convection fan is on default setting. On default setting the speed is synchronized with the auger feed rate. Selecting the grey fan icon will display the “FAN SPEED CONTROL” screen. This will allow you to bypass the default settings. Sliding to the left will reduce fan speed and sliding it to the right will increase fan speed. Note that you will be able to decrease the fan speed to the lowest possible but not able to increase the fan speed higher than the default fan speed for the current combustion level setting.

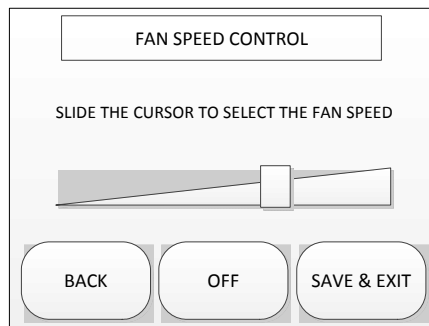

Fan with red arrows icon will display on the Main Status Page as you “SAVE & EXIT”. Fan speed reduction will be more noticeable on higher combustion level settings. To deactivate the fan speed reduction, select “OFF” from this page.

If overheating occurs, fan speed reduction will be automatically deactivated and an envelope icon



will replace the fan icon on the Main Status Page. Press on the envelope icon to view the warning message. Meanwhile, the convection fan will work at its highest setting until the stove reaches a safe temperature. Once the stove reaches that temperature, it will go back to the previously selected fan speed.

### 6.1.8 Selecting Manual or Thermostat Mode

To change operating mode press the thermometer icon , or, from the Main Status Page,

choose the letter icon  then select "SETUP" and "MODE".



Indicates that the stove is in manual mode. It will therefore run continuously on the selected setting until it is manually modified, turned OFF or if the stove runs out of pellets.



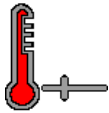

Indicates that the stove is in thermostat mode. The red waves indicate that the thermostat is calling for heat. It will heat at the selected combustion level until the thermostat has reached room temperature setting.



The waves will disappear once the thermostat has reached room temperature setting. At this time the combustion level will switch into the selected pilot mode until its cycle is completed. When thermostat calls for heat, the icon will change for the one with waves and combustion level will use the last setting.

### 6.1.9 Selecting the Pilot Cycle

**Note:** This icon will be visible on the Main Status Page only on thermostat mode.

To change the pilot cycle press the hourglass icon , or, from the Main Status Page, choose the letter icon  then select "SETUP" and "PILOT MODE".

You can choose from one of the five different pilot cycles: "ALWAYS OFF", "30 MINUTES", "45 MINUTES", "60 MINUTES" or "ALWAYS ON". The selected cycle will be displayed under the hourglass icon on the main status page. Default setting is "ALWAYS OFF" since this is the most fuel efficient configuration.



**Note:** Pilot feed rate is lower than the minimum combustion level feed rate.

#### 6.1.9.1 Always OFF

The pilot cycle begins when temperature set on the thermostat is reached. When the "ALWAYS OFF" pilot cycle is selected, the stove will shut down when the temperature set on the thermostat is reached. Every time the thermostat will call for heat, the stove will need to go through the complete ignition cycle.

#### 6.1.9.2 30 Minutes, 45 Minutes or 60 Minutes

The pilot cycle begins when temperature set on the thermostat is reached. It will last 30, 45 or 60 minutes depending of the selected pilot cycle. If the thermostat does not call for heat before the end of the selected pilot cycle delay, the stove will shut down and will need to go through the complete ignition cycle when the thermostat calls for heat again.

#### 6.1.9.3 Always ON

The pilot cycle begins when temperature set on the thermostat is reached. When the "ALWAYS ON" pilot cycle is selected, the stove stay on pilot mode until the thermostat calls for heat.

### 6.1.10 Filling or Purging Auger Housing

**Note:** This function is disabled when the stove is running.



To fill or purge the auger housing press the auger icon and select either “FEED AND START”, “PURGE SCREW” or “ADD PELLETS” in the displayed page.

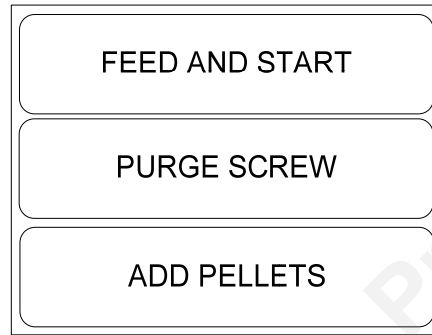

#### 6.1.10.1 Feed and Start

Use this option when you start the stove for the first time of the season or after the hopper ran out of pellets. The auger will turn for one minute then the stove will automatically start an ignition cycle.

#### 6.1.10.2 Purge Screw

Use this option to empty the auger at the end of the season. When selected, the auger will turn for two minutes.

#### 6.1.10.3 Add Pellets

Use this option to manually feed more pellet in the burn pot. When selected, the auger will turn for 20 seconds.

## 7 STOVE OPERATION

### 7.1 First Startup

Before starting your stove, make sure that the burn pot, the baffles and the maintenance access panels are properly installed. Also make sure that venting system is properly sealed and all doors are closed. Make sure the hopper is full; the hopper lid is closed and select the desired mode (manual or thermostat).



Press the auger icon on the Main Status Page followed by “FEED AND START” button in the displayed page.

If fire doesn't start within 20 minutes, a warning code **FAILED IGNITION** will appear. Refer to troubleshooting section for more details.

**WARNING: NEVER USE A GRATE OR OTHER MEANS OF SUPPORTING THE FUEL. ONLY USE THE STOVE APPROVED BURN POT.**

### 7.2 Everyday Startup

Before starting the stove, make sure there is enough pellets in the hopper and that the recommended maintenance schedule has been followed (see **Section 8.1.1 Recommended**

**maintenance schedule**) then press the “ON/OFF”  icon on the main status page.

### 7.3 Running Out of Pellets

If your stove runs out of pellets, the fire will slowly go out; the convection fan will run until the heat sensor on the exhaust fan reads 115°F. The cooling cycle will take a few minutes before all other motors stops. When this temperature is reached, a warning message “NO FUEL” will be displayed on the LCD screen.

To restart the stove, wait until all component stops running (usually 10 minutes after the warning message has been displayed). Press the “RESET” button, refill the hopper, and press the auger



icon on the Main Status Page followed by “FEED AND START” button in the displayed page.

### 7.4 Refilling



While the stove is running, you have up to 3 minutes to refill pellets in the hopper. Note that opening the hopper lid will stop the auger from feeding pellets to the stove. If the hopper lid is left open more than 3 minutes, the stove will stop and a warning code “HOPPER LID OPEN” will appear on the LCD screen. To restart the stove, close the lid, press the “RESET” button, and then



press the “ON/OFF” icon on the Main Status Page.

**NOTE: Keep hopper lid closed at all times except when refilling. Do not overfill the hopper.**

## 7.5 Shutting Down Procedure

To turn your stove off, press the “ON/OFF” icon  on the Main Status Page. The flame at the center of the icon will disappear  when the stove is turned off. The cooling cycle will take a few minutes and the blowers will continue to work while the stove is cooling down.

## 7.6 Signs of an Overheating Stove

Under normal conditions, the flame should have a bright yellow color and be very active, but stable (see **Appendix C: Flame Characteristics**). If you see the flame getting lazy, very high and orange, it may be a sign that there is something wrong. Usually, overheating issues are caused by too much restriction in the venting system, a blocked heat exchanger, a lack of combustion air or a lack of maintenance.

If this happens, your stove will become very hot. If the stove becomes too hot, “UNIT OVERHEAT” code will appear on the LCD screen. Before starting the stove again make sure the recommended maintenance has been done properly. Press the “RESET” button and then press the “ON/OFF”

icon  on the Main Status Page. If a “UNIT OVERHEAT” code occurs twice, call your dealer. He will be able to give you some advice so this code will not appear again. If the code appears more than three times, the LCD screen will lock itself up and you will need to call a service technician to unlock it.

**WARNING: IF YOU CHOOSE A STOVE THAT IS TOO SMALL FOR YOUR HOUSE AND YOU NEED TO OPERATE IT AT THE MAXIMUM SETTING FOR A LONG PERIOD OF TIME, YOU MAY END UP OVERHEATING THE STOVE. ALSO, STOVE AND COMPONENTS’S LIFE EXPECTANCY WILL BE REDUCED.**

**WARNING: IF ANY EXTERNAL PART OF THE STOVE BEGINS TO GLOW, YOU ARE OVERHEATING. IMMEDIATELY TURN YOUR STOVE OFF. DO NOT UNPLUG IT AND DO NOT OPEN THE DOOR. UNPLUGGING THE STOVE WILL DISABLE ALL THE SAFETY FEATURES ON THE STOVE.**

## 8 MAINTENANCE

### 8.1 Stove Maintenance

#### 8.1.1 Recommended Maintenance Schedule

Use this as a guide under average use conditions.

Components	Weekly or after +/- 250 pounds	Twice a year or after +/- 1 tons	Annually or per 2 tons of pellets
Baffle	Vacuum		
Bottom airwash inlet	Vacuum		
Burn Pot	Brush / Vacuum		
Glass	Clean		
Ash Drawer	Empty / Vacuum		
Combustion Chamber	Vacuum	Vacuum / Brush*	
Heat Exchanger Tubes	Brush	Scrape and Vacuum*	
Exhaust Channels (through access traps)		Vacuum*	
Exhaust Blower		Vacuum*	
Combustion Blower		Inspect*	
Convection Blower		Vacuum*	
Venting System		Inspect / Sweep*	Sweep and Clean
Gaskets		Inspect	
Hopper			Empty / Vacuum

\*Cleaning frequency may vary depending on the type of fuel used. Fuel with higher ash content will increase cleaning frequency. See **Section 5.2.1 Proper Fuel** for recommended combustibles.

**WARNING: FAILURE TO CLEAN AND MAINTAIN THIS STOVE AS INDICATED CAN RESULT IN POOR PERFORMANCE AND SAFETY HAZARDS.**

**WARNING: NEVER CLEAN WHEN HOT.**

**WARNING: THE USE OF A DOMESTIC, CENTRAL OR COMMERCIAL VACUUM CLEANER TO PERFORM THE MAINTENANCE OF YOUR PELLET STOVE IS NOT RECOMMENDED. ASH PARTICLES MAY DAMAGE THE MOTORS OF THESE APPLIANCES. FURTHERMORE, EMBERS THAT ARE STILL HOT MAY SET YOUR VACCUM CLEANER'S CONTENT ON FIRE. THE USE OF AN ASH VACCUM CLEANER IS HIGHLY RECOMMENDED.**

**WARNING: ASHES SHOULD BE PLACED IN A METAL CONTAINER WITH A TIGHT FITTING LID. THE CLOSED METAL CONTAINER SHOULD BE PLACED ON A NONCOMBUSTIBLE SURFACE, WELL AWAY FROM ALL COMBUSTIBLE MATERIALS, PENDING FINAL DISPOSAL. IF THE ASHES ARE DISPOSED OF BY BURIAL IN SOIL OR OTHERWISE LOCALLY DISPERSED, THEY SHOULD BE RETAINED IN THE CLOSED CONTAINER UNTIL ALL CINDERS HAVE BEEN THOROUGHLY COOLED.**

### 8.1.2 Cleaning the Baffle, the Heat Exchangers and the Combustion Chamber

Remove and clean the three parts of the baffle that are located inside the combustion chamber. Use the small metal tabs to remove the panels in the order shown on the following pictures. Vacuum heat exchanger tubes. Remove the panels in the order shown on the pictures below.



### 8.1.3 Cleaning the Burn Pot

Burn pot must stay clean and holes should not be obstructed by combustion residues (ashes, clinkers).

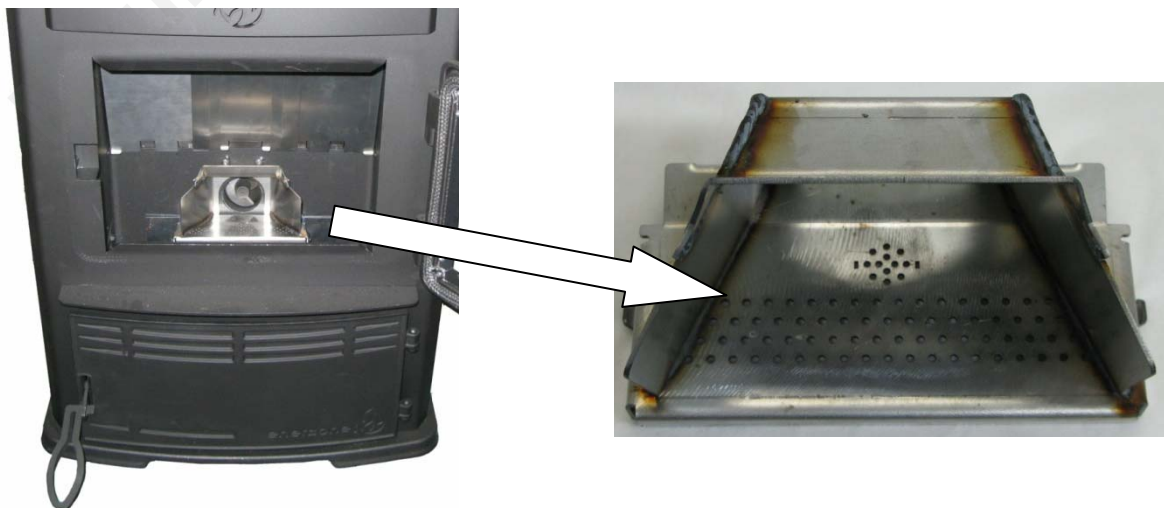

1. Clean the burn pot using the scraper provided with the stove or a brush.



2. Release the clips on both sides of the burn pot then, remove the burn pot by lifting and pulling it out. Once the burn pot is removed make sure all holes are clean. Clean thoroughly under the burn pot with an ash vacuum to remove ashes that may have accumulated.

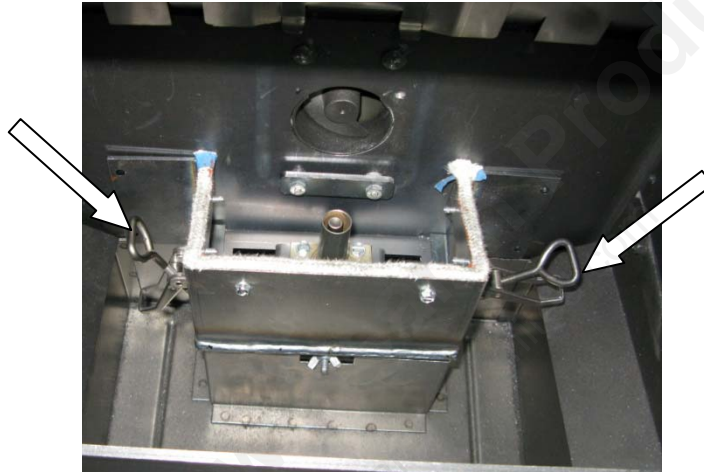

3. If necessary, clean the air intake channel. To reach the air intake channel clean out trap, open the ash drawer access door and remove the ash drawer. Unscrew the wing nut to open the clean out trap. Vacuum the combustion residues.

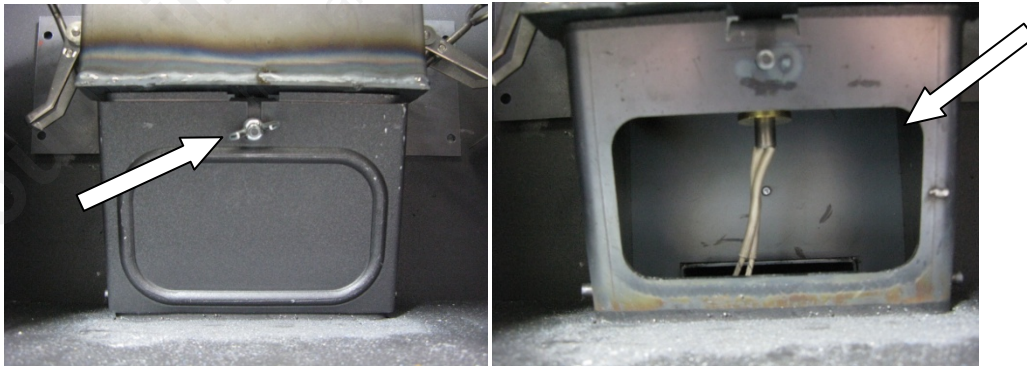

4. Verify that the clean out trap gasket is still in good condition, replace it if needed.



#### 8.1.4 Ash Removal

1. To empty the ash drawer of its contents, open the ash pan access door by lifting the latch with the drawer handle provided. (A bracket to hold the drawer handle is located on the right side of the stove, at the back).



2. Vacuum around the ash drawer and at the bottom of the combustion chamber.

**WARNING: ASH PAN MUST BE IN PLACE AND THE ASH PAN ACCESS DOOR MUST BE KEPT CLOSED WHEN THE STOVE IS IN USE.**



### 8.1.5 Cleaning the Air Wash System

Vacuum the ashes that may have accumulated in the airwash system inlet between the bottom glass retainer and the glass. This will allow an optimum air flow along the inside portion of the glass and prevents the glass from sooting-up.

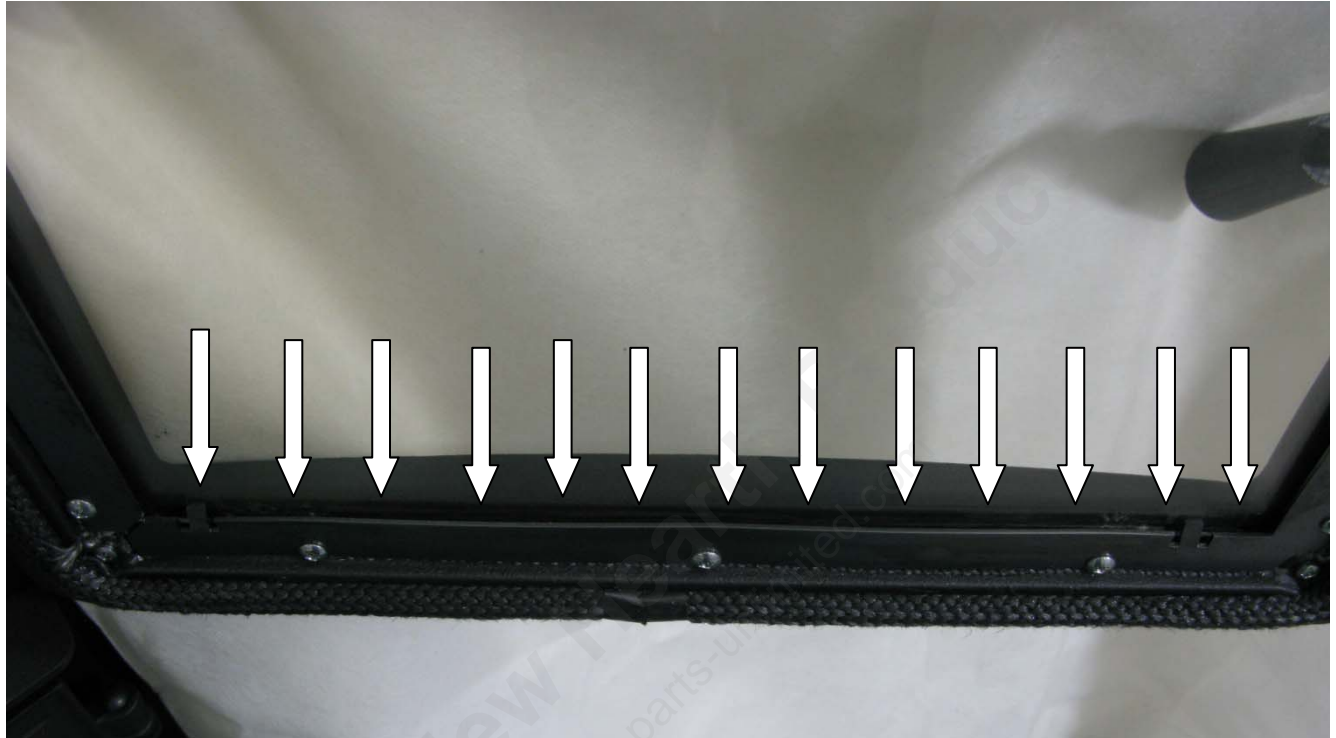

### 8.1.6 Glass Care

Clean door glass as necessary. The use of a stove glass cleaner is recommended. Regular household glass cleaners will not clean creosote.

**WARNING: NEVER USE ABRASIVE CLEANERS ON THE GLASS OR ON ANY PLATED PART.**

**WARNING: DO NOT CLEAN THE GLASS WHILE IT'S HOT.**

**WARNING: DO NOT FORCE, STRIKE OR ADOPT ANY BEHAVIOUR THAT COULD WEAKEN THE GLASS DOOR.**

**WARNING: DO NOT OPERATE THE STOVE WITH THE GLASS REMOVED, CRACKED OR BROKEN.**

### 8.1.7 Replacement of Broken Door Glass

Carefully remove any loose pieces of glass from the doorframe. Dispose all broken glass properly.

A broken glass must be replaced with an identical ROBAX (ceramic glass) 5 mm thick with the dimensions: 9" 11/64 x 14" 43/64". Refer to replacement parts section.

**WARNING: ALWAYS WEAR SUITABLE GLOVES WHILE HANDLING BROKEN GLASS.**

**WARNING: REPLACEMENT GLASS SHOULD ONLY BE PURCHASED FROM AN AUTHORIZED DEALER (SEE "REPLACEMENT PARTS" SECTION). TEMPERED GLASS OR ORDINARY GLASS WILL NOT WITHSTAND THE HIGH TEMPERATURES OF THE STOVE.**

**WARNING: IF YOU HAVE TO CHANGE THE DOOR GLASS, MAKE SURE YOU INSTALL THE NEW GASKETS AT THE SAME PLACE AS THE ORIGINAL IN ORDER TO KEEP THE AIRWASH WORKING PROPERLY.**

### 8.1.8 Door Gasket Maintenance

It is important to maintain the door gasket in good condition. After a while, the gasket will wear and compress; adjusting the door may then be required. If the door adjustment is not sufficient, replace the door gasket with a genuine one. If the stove door is not properly sealed, it will be difficult to keep the door glass clean and combustion gases may leak into the room.

### 8.1.9 Door Adjustment

In order for your stove to burn at its best efficiency, the door must provide a perfect seal with the firebox. Therefore, the gasket should be inspected periodically making sure to obtain an air tight fit. Airtightness can be improved with a simple latch mechanism adjustment. To adjust:

1. Remove the lock pin by pulling and turning with pliers and turn the handle counter clockwise one turn to increase pressure.
2. Re-install the lock pin (spring pin) with a small hammer

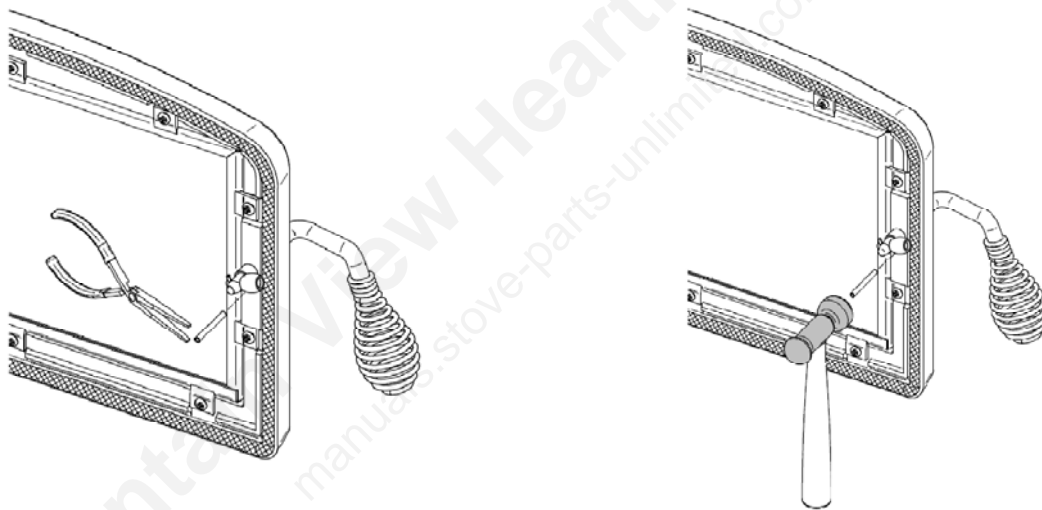

### 8.1.10 Exhaust Channel and Exhaust Blower Maintenance.

Exhaust channels and the exhaust blower are located on the left hand side of the stove. The following procedure demonstrates how to perform inspection and cleaning:

In order to access the exhaust channels, open the left side decorative panels. Remove them if necessary (Refer to decorative panel instruction sheet). Remove the two clean out trap. To remove the clean out traps, you will need to unlock them first. Using a Philips or Robertson screwdriver, push and turn the screw counter-clockwise and pull on the trap.

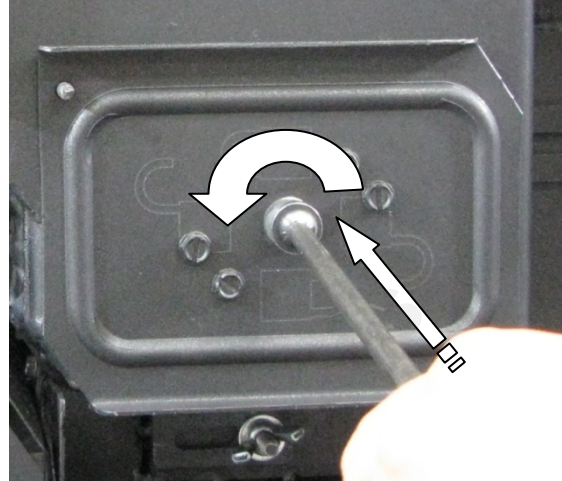
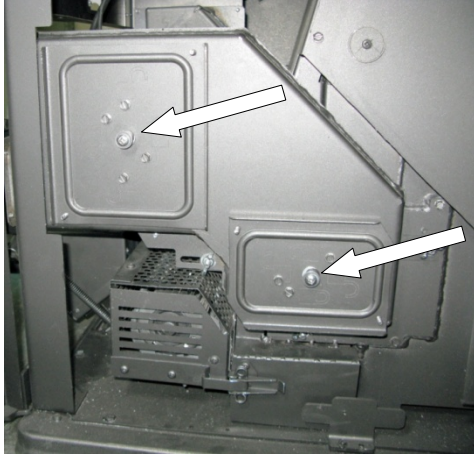

Clean and vacuum any dirt or ash build-up in the exhaust channels and exhaust blower housing being careful not to damage the blower's blades. Use the scraper provided with the stove to clean heat exchanger outlet.

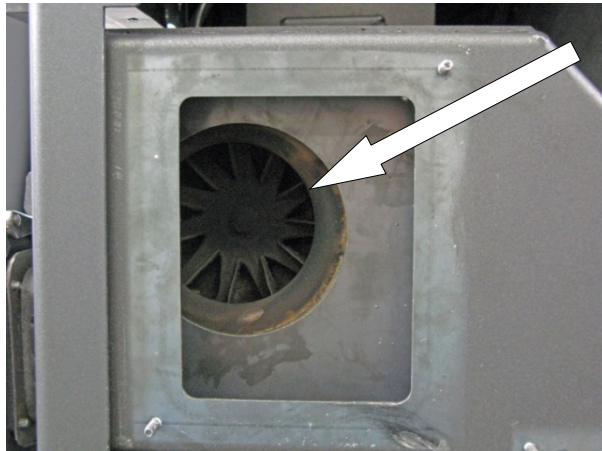

Make sure the gaskets are still in good condition, replace them if needed.



## 8.2 Venting System Maintenance

**CAUTION: REGULARLY EXAMINE THE VENTING SYSTEM, THE JOINTS, AND THE SEALING TRIMS TO ENSURE THAT THE SMOKE AND THE COMBUSTION GASES ARE NOT DRAWN BY THE CONVECTION BLOWER.**

The most efficient method to sweep the venting system is by using a 3" or 4" pellet brush depending on your installation. Brush downwards so ash, soot and creosote residues will come off the inner surface and fall at the bottom of the clean out tee where they can be easily removed. The venting system must be in good condition and kept clean.

**WARNING: IF A SIGNIFICANT LAYER OF CREOSOTE HAS ACCUMULATED (3MM / 1/8" OR MORE), IT MUST BE REMOVED IMMEDIATELY TO ELIMINATE THE RISK OF A CHIMNEY FIRE.**

### 8.2.1 Dealing With a Chimney Fire

Regular chimney maintenance and inspection can prevent chimney fires. If you have a chimney fire, follow these steps:

1. Alert your family of a possible danger.
2. If you need assistance, call the fire department;
3. If possible, use a dry chemical fire extinguisher, baking soda or sand to control the fire. Do not use water, as it may cause dangerous vapour explosions.
4. Check outside to ensure that sparks and hot embers coming out of the chimney are not igniting any combustible material close by;
5. Do not use the stove again until your chimney and stove have been inspected by a qualified chimney sweep or a Fire Department Inspector;

**CAUTION: CLEANOUT OF THE STOVE AND THE VENTING SYSTEM IS ESPECIALLY IMPORTANT AT THE END OF THE HEATING SEASON TO MINIMIZE CORROSION DURING THE SUMMER MONTHS, CAUSED BY ACCUMULATED ASH.**

### 8.2.2 Soot and Fly Ash

The combustion products contain small particles of fly ash. Fly ash can accumulate especially in horizontal sections of exhaust pipe and restrict the flow of combustion gases. Incomplete combustion, produced when igniting, shut down or misuse of the stove will cause some soot formation which can accumulate in venting system. The venting system must be inspected at least twice a year to determine if cleaning is necessary.

## 9 TROUBLESHOOTING

When you have issues with your stove, your first reaction may be to call technical support. This section will help you save time and money by enabling you to solve simple problems by yourself.

Most common problems are generally caused by the following five factors:

1. Wrong operation or lack of maintenance;
2. Bad installation;
3. Poor quality combustible;
4. Component failure;
5. Factory defect.

The stove is equipped with a pc board that allows the stove to diagnose itself. It is thus important not to unplug the stove if there is an issue with it. First, because unplugging the stove will disable all the security features of the stove, and second, because you will not be able to see the error code given by the stove to understand what is the problem. It is thus important to read carefully this section before calling technical support.

The following sections will help you test each component individually and will also give you many tips in how to solve any problems related to a specific error code.

**NOTE: IF YOU NEED TO CONTACT YOUR DEALER OR TECHNICAL SUPPORT, MAKE SURE TO HAVE THE MODEL OF YOUR STOVE AND THE SERIAL NUMBER ON HAND. (THEY CAN BE FOUND ON THE CERTIFICATION LABEL INSIDE THE HOPPER LID).**

### 9.1 Validating Status

When using your stove, you can validate at any time, the status of any of the following components:

- Electronic components (low power rated)
  - o *F160 (security heat sensor)*
  - o *L-250A (security heat sensor)*
  - o *Pressure switch (security sensor)*
  - o *Hopper switch (mechanical security sensor)*
  - o *Thermostat (temperature regulator device)*
- Electrical components (high power rated)
  - o *Igniter (heater)*
  - o *Combustion blower (will feed fire with fresh air)*
  - o *Convection blower (will send hot air into the room)*
  - o *Exhaust blower (will extract combustion gas out of the stove)*
  - o *Auger motor 1 (located under the hopper)*
  - o *Auger motor 2 (will feed the fire with pellets)*



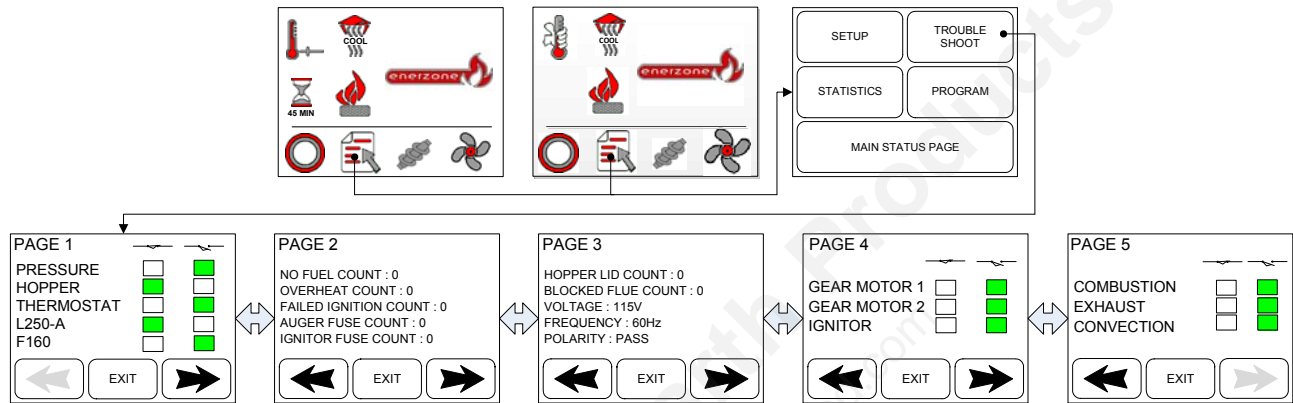

**WARNING: RISK OF ELECTRICAL SHOCK. IF YOU NEED TO MANUALLY TEST, MANIPULATE OR REPLACE ANY COMPONENTS, THE STOVE NEEDS TO BE DISCONNECTED FROM THE WALL OUTLET.**

To validate the status of a component, you need to go to the “TROUBLESHOOT” page. From the

Main Status Page, Press the “LETTER” icon  and choose “TROUBLESHOOT” in the menu. Once there you will be able to navigate through 5 pages.



On page 1 you will see a list of every electronic component status. If the square has a green color, it means the status of the component is normal, regardless if it is on the left or right column. If the square has a red color, it means that its status is abnormal. This screen will give you status in real time, meaning that when the stove is running, if a component status change, you will see it right away. Page 2 and 3 will give you statistics on how many times you had a specific error code.

WITH GREEN ICONS		
PRESSURE		Pressure switch is at closed state. This is normal state.
PRESSURE		Pressure switch is at opened state. This is normal state.
WITH RED ICONS		
PRESSURE		Pressure switch is at closed state. This is abnormal state.
PRESSURE		Pressure switch is at opened state. This is abnormal state.

## 9.2 Testing Components

If you suspect an electrical component to be defective, you can test it from the “TROUBLESHOOT”

page. From the Main Status Page, Press the “LETTER” icon  and choose “TROUBLESHOOT”

in the menu. Page 4 and 5 will allow you to test every electrical component. Note that you will be able to test only components when the stove is cold (showing this icon  ).

For example, if you press on the white square next to “GEAR MOTOR 1”, the auger 1 will turn for 30 seconds. This will give you the possibility to see the auger turning and hear the motor running as well.

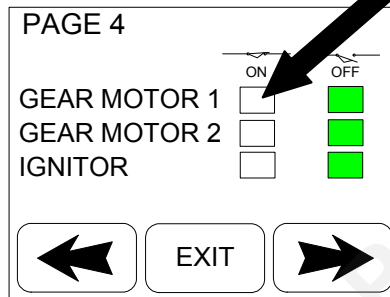

### 9.3 Main Error Codes, Possible Causes and Solutions

**WARNING: RISK OF ELECTRICAL SHOCK. IF YOU NEED TO MANUALLY TEST, MANIPULATE OR REPLACE ANY COMPONENTS, THE STOVE NEEDS TO BE DISCONNECTED FROM THE WALL OUTLET.**

This section contains main error codes, possible causes and many suggestions to guide you in resolving them. After giving an error code, your stove will shut down by itself and start a cool down

cycle. If you want to start your stove again, you will need to press on the



button

and then on the “ON/OFF” button . Your stove will only restart when the cool down cycle is completed.

**NOTE: IF, AFTER PERFORMING ALL THE POSSIBLE SOLUTIONS MENTIONED IN THE FOLLOWING SECTION, YOU ARE STILL EXPERIENCING PROBLEMS WITH YOUR STOVE, CALL YOUR LOCAL DEALER OR A SERVICE TECHNICIAN AT (418) 878-3040. YOU CAN ALSO WRITE AN EMAIL TO [TECH@SBI-INTERNATIONAL.COM](mailto:TECH@SBI-INTERNATIONAL.COM). ALL EMAILS ARE ANSWERED WITHIN A 24H DELAY.**

**NOTE: IF YOU NEED TO CONTACT YOUR DEALER OR TECHNICAL SUPPORT, MAKE SURE TO HAVE THE MODEL OF YOUR STOVE AND THE SERIAL NUMBER ON HAND. (THEY CAN BE FOUND ON THE CERTIFICATION LABEL INSIDE THE HOPPER LID).**

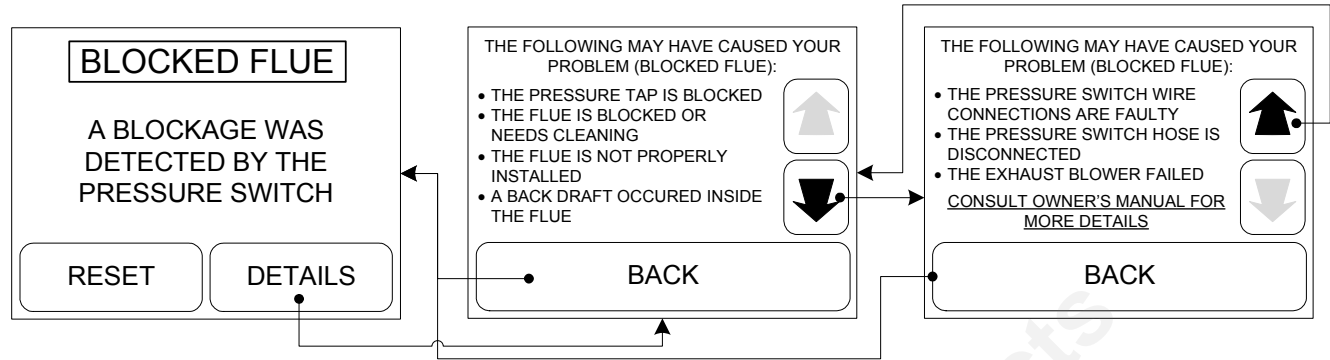

- ❖ **Pressure tap (located on the exhaust blower) is blocked.** Pull off the air hose from the exhaust blower pressure tap and the white (-) pressure switch tap. Use a thin wire to clear the pressure tap blockage and blow through the hose. If air flows freely, the hose is fine. If air does not flow through the hose, use a thin wire to clear the blockage.
- ❖ **The flue is blocked or needs cleaning.** One of the following components is obstructed or blocked by ashes or by a foreign object; air intake shutter, combustion blower, burn pot, heat exchangers and exhaust channels, exhaust blower and or venting system. Refer to the maintenance section.
- ❖ **The flue is not properly installed.** Make sure the venting system meets the criteria in the installation section of this manual as well as the venting system manufacturer's instructions.
- ❖ **A back draft occurred inside the flue.** This can occur on a very windy day or if your venting system does not have a proper termination.
- ❖ **The pressure switch wire connections are faulty.** Make sure that the pressure switch wires and connections are not grounded or loose. Replace or replug wires if necessary.
- ❖ **The pressure switch hose is disconnected.** Make sure the pressure switch hose is well installed on the exhaust blower pressure tap and on the white (-) pressure switch tap. If not, reinstall it.
- ❖ **The exhaust or combustion blower failed.** Go to the troubleshooting page on the LCD screen and test the combustion and the exhaust blowers independently (see **Section 9.2 Testing Components**). If one of them does not work, make sure there is power and that blowers are well connected. If they still don't work, check F4 and F5 fuse on the control board. If the fuses are good, the combustion or exhaust blower is probably defective; Replace part.
- ❖ **Pressure switch is defective.** Even if this is very rare, the pressure switch could be defective. To test it, go to the troubleshooting page on the LCD (see **Section 9.2 Testing Components**) and start the exhaust blower. If the pressure switch square switch from the right column to the left column, it means the pressure switch works. If not, the pressure switch is defective and needs to be replaced.

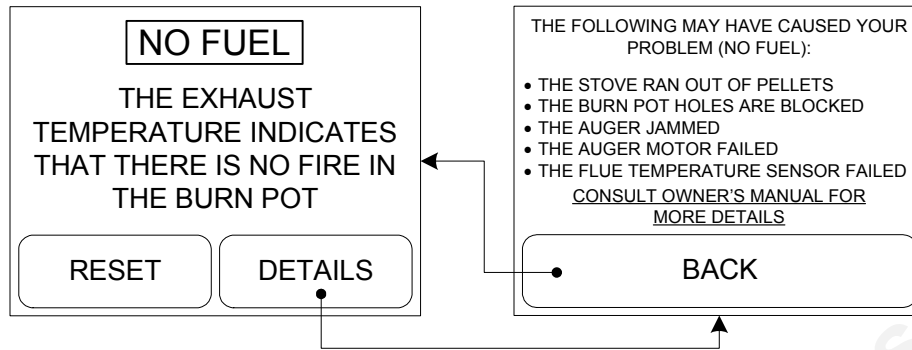

- ❖ **The stove ran out of pellets.** Refill the hopper. Press “Reset” then “Feed and Start”.
- ❖ **The burn pot holes are blocked.** Remove the burn pot and clean it thoroughly.
- ❖ **The auger is jammed or auger motor failed.** Go to the troubleshooting page on the LCD (see **Section 9.2 Testing Components**) screen and test auger motors. If one of the motors is not running check if motor is defective or if the auger is jammed.

**NOTE:** IF THE HOPPER AUGER MOTOR FAILED OR THE HOPPER AUGER IS JAMMED, TO AVOID PELLET SPILLAGE, EMPTY THE HOPPER OF ITS CONTENTS BEFORE EXECUTING THE FOLLOWING TESTS.

- If the auger motor is defective, check to make sure that electrical connections are not loose and check the fuses F2 and F6 on the control board. If the fuses are good, remove the faulty auger motor from its auger housing and retest the motor separately still using the troubleshooting test mode. Make sure the hopper lid is closed. If the motor works, the auger may be jammed by a foreign object. If no signs of obstruction are found, call your dealer or a service technician to perform a complete testing.
- If the hopper auger is jammed, start by emptying the hopper. If it is the burn pot auger you don’t need to empty the hopper. To remove both augers from their housing you need to disconnect auger motor and then remove the four screws on the steel plate that holds the auger shaft to the auger housing. You may need to remove the rear panel for an easier access. Pull out the auger from the housing. Once the auger has been removed, make sure the auger is straight, his surface is not damaged and there are no burrs, or broken welds. Remove any foreign material that may have caused the jam. Inspect the auger housing for signs of damage such as burrs, rough spots, or grooves cut into the metal that could have caused a jam. Clean the auger housing thoroughly to remove all pellet dust.
- ❖ **The flue temperature sensor failed.** The “Thermistor” is a heat sensor located on the exhaust motor housing. Its function is to tell the control board that the stove has ignited properly by measuring the heat at the exhaust. When your stove is cold, check if the exhaust



blower temperature icon is showing cool . If yes, start the stove and monitor temperature. If after 10 minutes, the icon is still showing cool, the sensor is disconnected or defective. If the icon changes and the temperature rise, you may have a problem on minimum feed rate or pilot mode. Depending on many factors (ambient temperature, pellet quality, etc) the heat produced by the stove may not be sufficient to keep the exhaust temperature high enough. To resolve the situation increase feed rate (see **Section 6.1.6 Adjusting the Combustion Level (Heat Output)**).

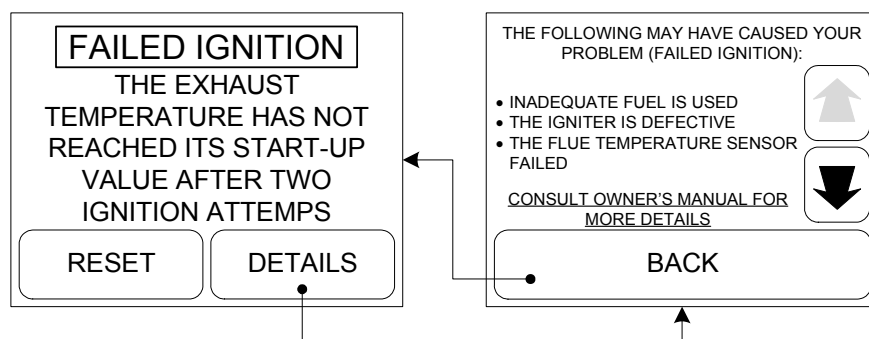

- ❖ **Inadequate fuel is used.** Remove the burn pot, make sure that all openings are clear and check that no ash has filled the tube around the igniter. Refer to the maintenance section. Also, make sure that recommended fuel is used (see **Section 5.2.1 Proper Fuel**).
- ❖ **The igniter is defective.** Go to the troubleshooting page (see **Section 9.2 Testing Components**) and follow instructions for component check. Test the ignitor to see if it glows. It should take no longer than two minutes. If it does not glow, check the wiring and the F3 fuse. If the wiring is properly connected and the fuse is good, test the continuity of the igniter with a multimeter.
- ❖ **The flue temperature sensor failed.** The “Thermistor” is a heat sensor located on the exhaust motor housing. Its function is to tell the control board that the stove has ignited properly by measuring the heat at the exhaust. When your stove is cold, check if the exhaust



blower temperature icon is showing cool . If yes, start the stove and monitor temperature. If after 10 minutes, the icon is still showing cool, the sensor is disconnected or defective. If the icon changes and the temperature rise, you may have a problem on minimum feed rate or pilot mode. Depending on many factors (ambient temperature, pellet quality, etc) the heat produced by the stove may not be sufficient to keep the exhaust temperature high enough. To resolve the situation increase feed rate, (see **Section 6.1.6 Adjusting the Combustion Level (Heat Output)**).

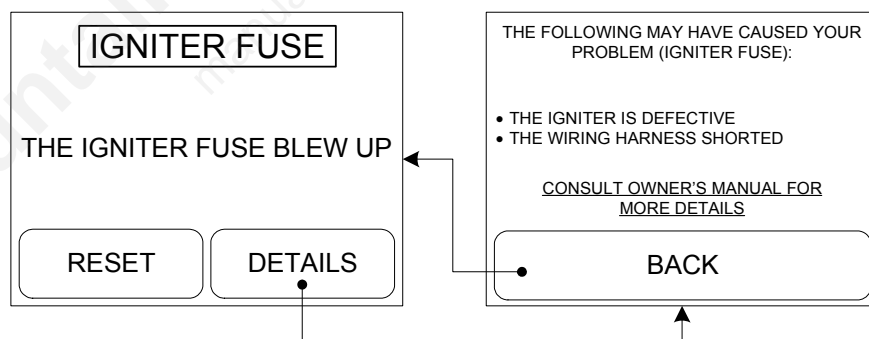

- ❖ **The igniter is defective:** Test the continuity of the igniter with a multimeter. If it is good, the ignitor is good. If it is defective, replace it and the F3 fuse.
- ❖ **The wiring harness shorted.** Inspect the wiring and replace any defective wire and or connector. Make sure the wires are not shorted to the stove frame. Locate the fuse F3 on the control board and replace it. Go to the troubleshooting page (see **Section 9.2 Testing Components**) and follow instructions for component check. Test the ignitor to see if it glows. It should take no longer than two minutes.

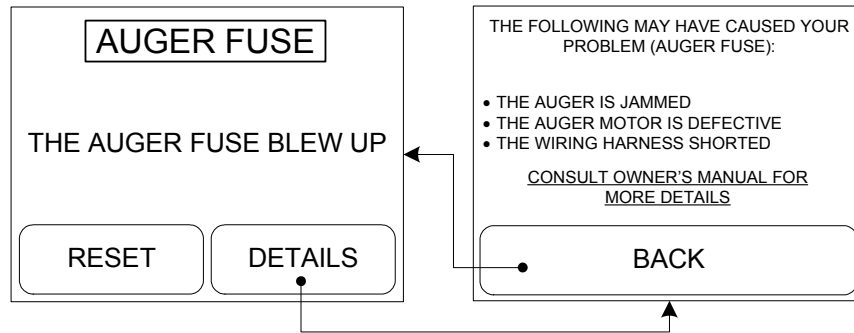

- ❖ **The auger is jammed or auger motor failed.** Go to the troubleshooting page (see **Section 9.2 Testing components**) on the LCD screen and test auger motors. If one of the motors is not running check if motor is defective or jammed.

**NOTE :** IF THE HOPPER AUGER MOTOR FAILED OR THE HOPPER AUGER IS JAMMED, TO AVOID PELLET SPILLAGE, EMPTY THE HOPPER OF ITS CONTENTS BEFORE EXECUTING THE FOLLOWING TESTS.

- If the auger motor is defective, check to make sure that electrical connections are not loose and check the fuses F2 and F6 on the control board. If the fuses are good, remove the faulty auger motor from its auger housing and retest the motor separately still using the troubleshooting test mode. Make sure the hopper lid is closed. If the motor works, the auger may be jammed by a foreign object. If no signs of obstruction are found, call your dealer or a service technician to perform a complete testing.
- If the hopper auger is jammed, start by emptying the hopper. If it is the burn pot auger you don't need to empty the hopper. To remove both augers from their housing you need to disconnect auger motor and then remove the four screws on the steel plate that holds the auger shaft to the auger housing. You may need to remove the rear panel for an easier access. Pull out the auger from the housing. Once the auger has been removed, make sure there are no bent flights, burrs, or broken welds. Remove any foreign material that may have caused the jam. Inspect the auger housing for signs of damage such as burrs, rough spots, or grooves cut into the metal that could have caused a jam. Clean the auger housing thoroughly to remove all pellet dust.

- ❖ **The wiring harness shorted.** Make sure the auger motor wiring is properly connected and not shorted.

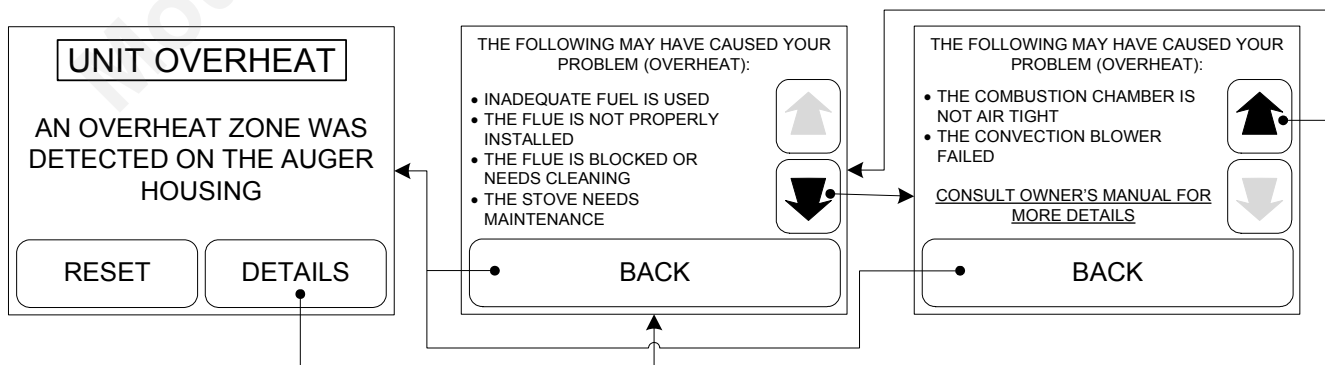

- ❖ **Inadequate fuel is used.** Remove the burn pot, make sure that all openings are clear and check that no ash has filled the tube around the igniter. Refer to the maintenance section. Also, make sure that recommended fuel is used (see **Section 5.2.1 Proper Fuel**).

- ❖ **The flue is not properly installed.** Make sure the venting system meets the criteria in the installation section of this manual as well as the venting system manufacturer's instructions.
- ❖ **The flue is blocked or needs cleaning.** One of the following components is obstructed or blocked; air intake shutter, combustion blower, burn pot, heat exchangers and channels, exhaust blower and or venting system. Refer to the maintenance section.
- ❖ **The stove needs maintenance.** Refer to maintenance section.
- ❖ **The burn pot is not installed properly.** Make sure the burn pot is well installed and locked in place.
- ❖ **The baffle is not installed properly.** Make sure all three panels are well installed.
- ❖ **The convection blower is defective.** Go to the troubleshooting page (see **Section 9.2 Testing Components**) on the LCD screen and test the convection blower.
- ❖ **The convection blower needs maintenance.** Carefully clean blower housing and make sure blower louvers are not blocked.

**NOTE: IF THE CODE APPEARS MORE THAN THREE TIMES, THE LCD SCREEN WILL LOCK ITSELF UP AND YOU WILL NEED TO CALL A SERVICE TECHNICIAN TO UNLOCK IT.**

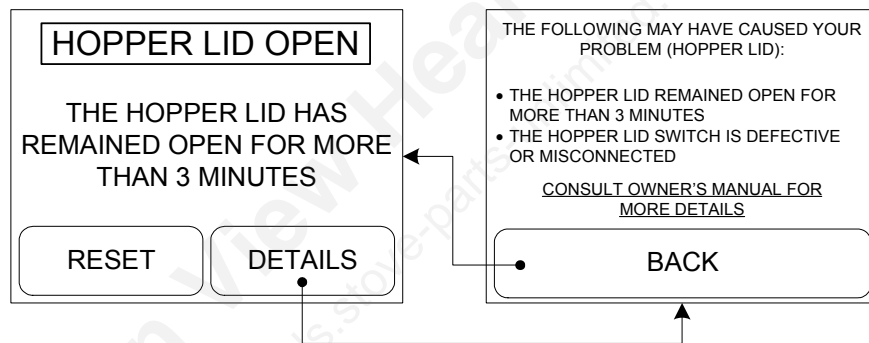

- ❖ **The hopper lid remained open for more than 3 minutes.** As a security measure, the auger stops turning and feeding pellets as soon as the hopper lid opens. It will resume normal operation as soon as the hopper lid is closed. If the hopper lid stays open for more than 3 minutes, the stove will stop.
- ❖ **The hopper lid switch is defective or misconnected.** Make sure the switch is properly connected. If it is, the hopper switch may be defective. Go to the troubleshooting page (see **Section 9.2 Testing Components**) and check the functionality of the switch. Replace if necessary.

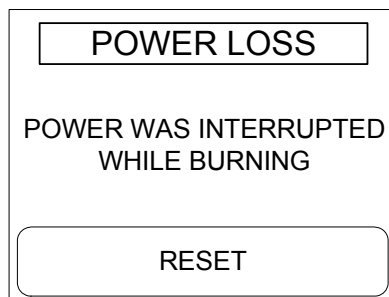

- ❖ **Power was interrupted while burning.** After the cool down cycle, the stove will restart using the last settings. Press “RESET” to go back to the Main Status Page.

**Note:** For a short power failure (less than 5 seconds), the stove will continue to function at the selected speed.

### **SMOKE SMELL**

- ❖ **Venting system leaks.** Inspect all vent connections. This is a pressurized venting system. All vent connector joints must be sealed and fastened in accordance with the pellet vent manufacturer's instructions to ensure consistent performance and avoid smoke and ash spillage.
- ❖ **Worn gasket.** Gaskets may be leaking (Doors, clean out traps, etc). Make sure that all gaskets are in good condition and replace them with original parts if necessary. Make sure the door is well adjusted (see **Section 8.1.9 Door Adjustment**).
- ❖ **Negative pressure.** A faint wood-burning odor during ignition or shut down is normal. Although, if this increases beyond normal or if you notice an unusual soot build-up on walls or furniture, check your venting system carefully for leaks and make sure all gaskets are in good condition. Also, make sure recommended maintenance schedule has been performed. Note that you may need to add a fresh air kit to your stove to solve this problem. (see **Appendix F : Combustion Air supply**)

### **COMBUSTION AIR STARVATION**

- ❖ **Venting system is dirty.** Refer to the maintenance section of this manual.
- ❖ **The flue is not properly installed.** Make sure the venting system meets the criteria in the installation section of this manual as well as the venting system manufacturer's instructions.
- ❖ **Inadequate fuel is used.** Remove the burn pot, make sure that all openings are clear and check that no ash has filled the tube around the igniter. Refer to the maintenance section. Also, make sure that recommended fuel is used (see **Section 5.2.1 Proper Fuel**) and settings are adjusted to the type of pellets that are being used (see **Section 6.1.6 Adjusting the Combustion Level (Heat Output)**).
- ❖ **Air intake channel is restricted.** Visually inspect the air intake channel that leads to the burn pot for foreign material. Make sure that the air-intake shutter is functional and free of any obstruction.
- ❖ **The combustion/exhaust blower failed.** Go to the troubleshooting page on the LCD screen and test the combustion and the exhaust blowers independently (see **Section 9.2 Testing Components**). If one of them does not work, make sure there is power and that blowers are well connected. If they still don't work, check F4 and F5 fuse on the control board. If the fuses are good, the combustion or exhaust blower is probably defective; Replace part.

### **THE LCD TOUCH SCREEN DOES NOT LIGHT.**

- ❖ **There is no current going to the stove.** Check if the stove is connected and if there is current in the wall outlet. Check if the F7 fuse is blown. Replace it if necessary.
- ❖ **TELCO wire is defective or not connected properly.** Convection blower, combustion blower, exhaust blower and burn pot auger will start but the stove will beep continuously and the LCD touch screen will remain black. Check connection and change wire, if necessary.

# 10 WIRING DIAGRAM

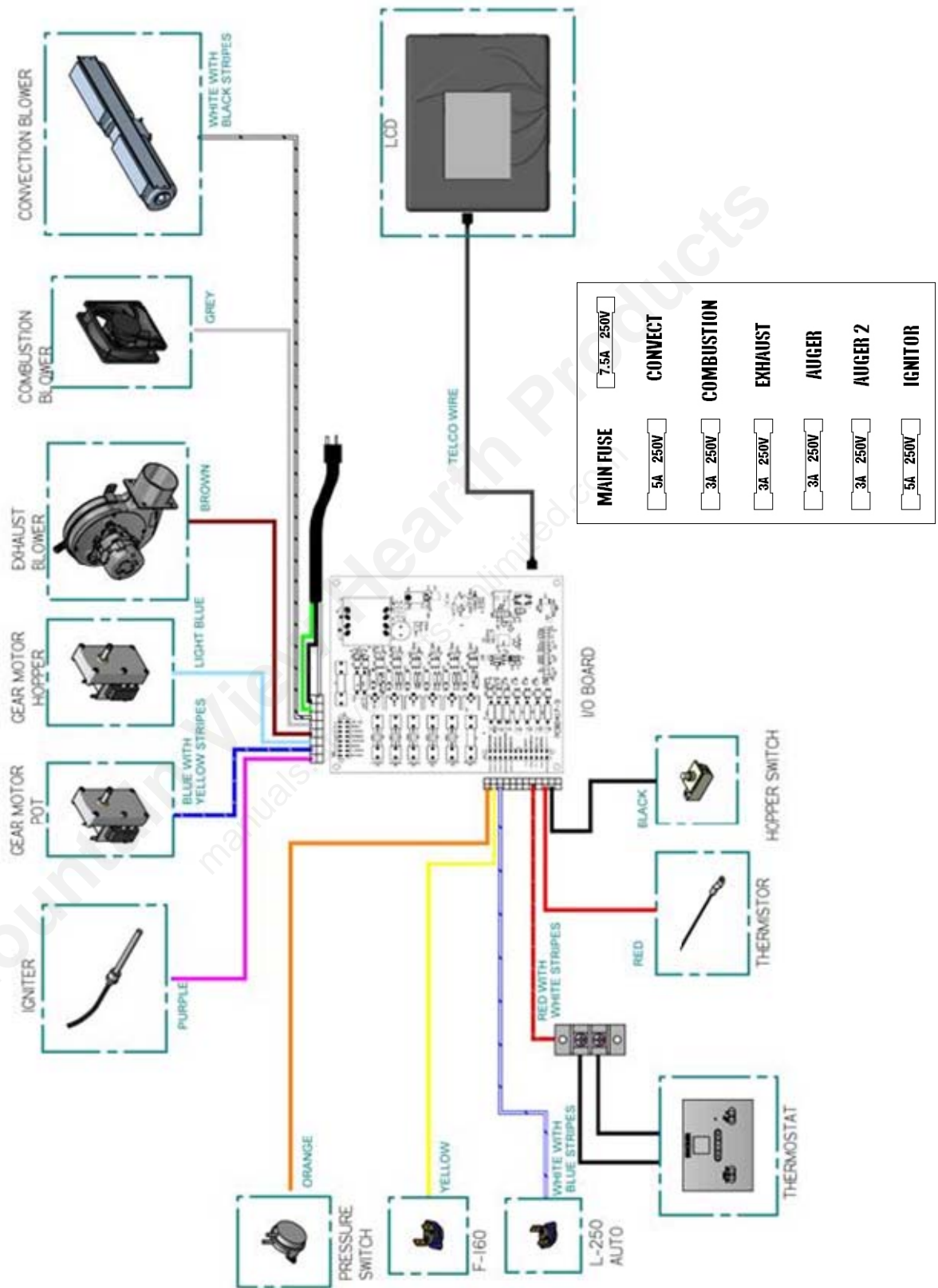

## 11 FUSES ACCESS

**WARNING: UNPLUG THE STOVE BEFORE CHANGING THE FUSES.**

All fuses are located inside the housing of the electronic board; the housing is on the back of your stove. Unplug your stove and turn the four spring clip to open the housing.

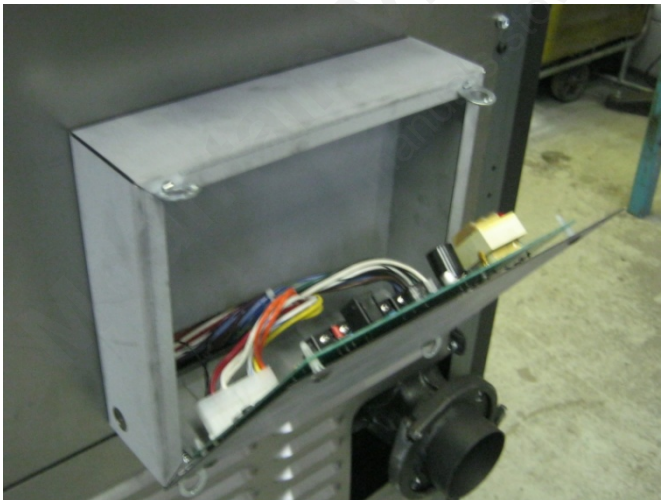

# 12 COMPONENT LOCATION

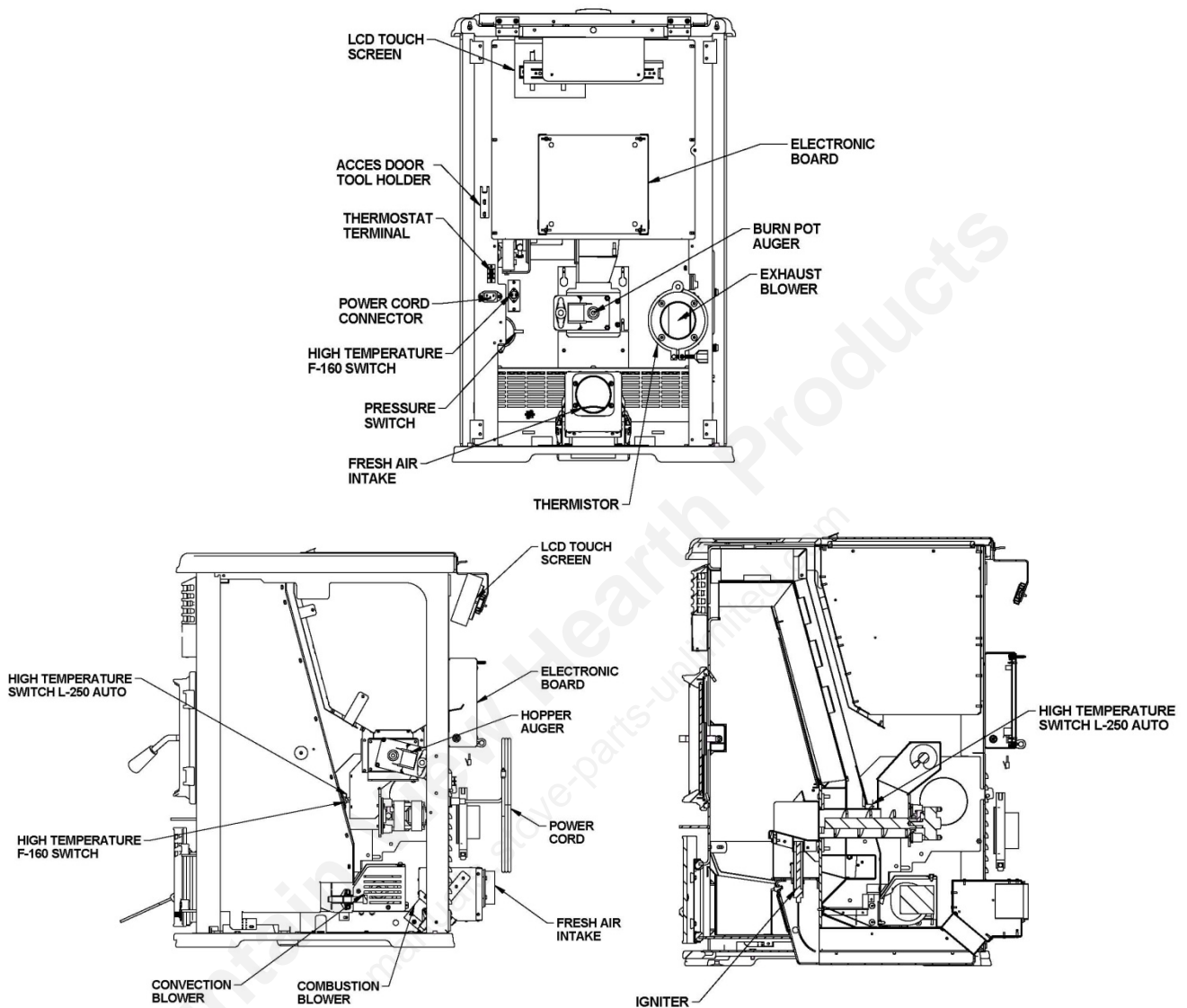

# 13 EXPLODED VIEW AND REPLACEMENT PARTS

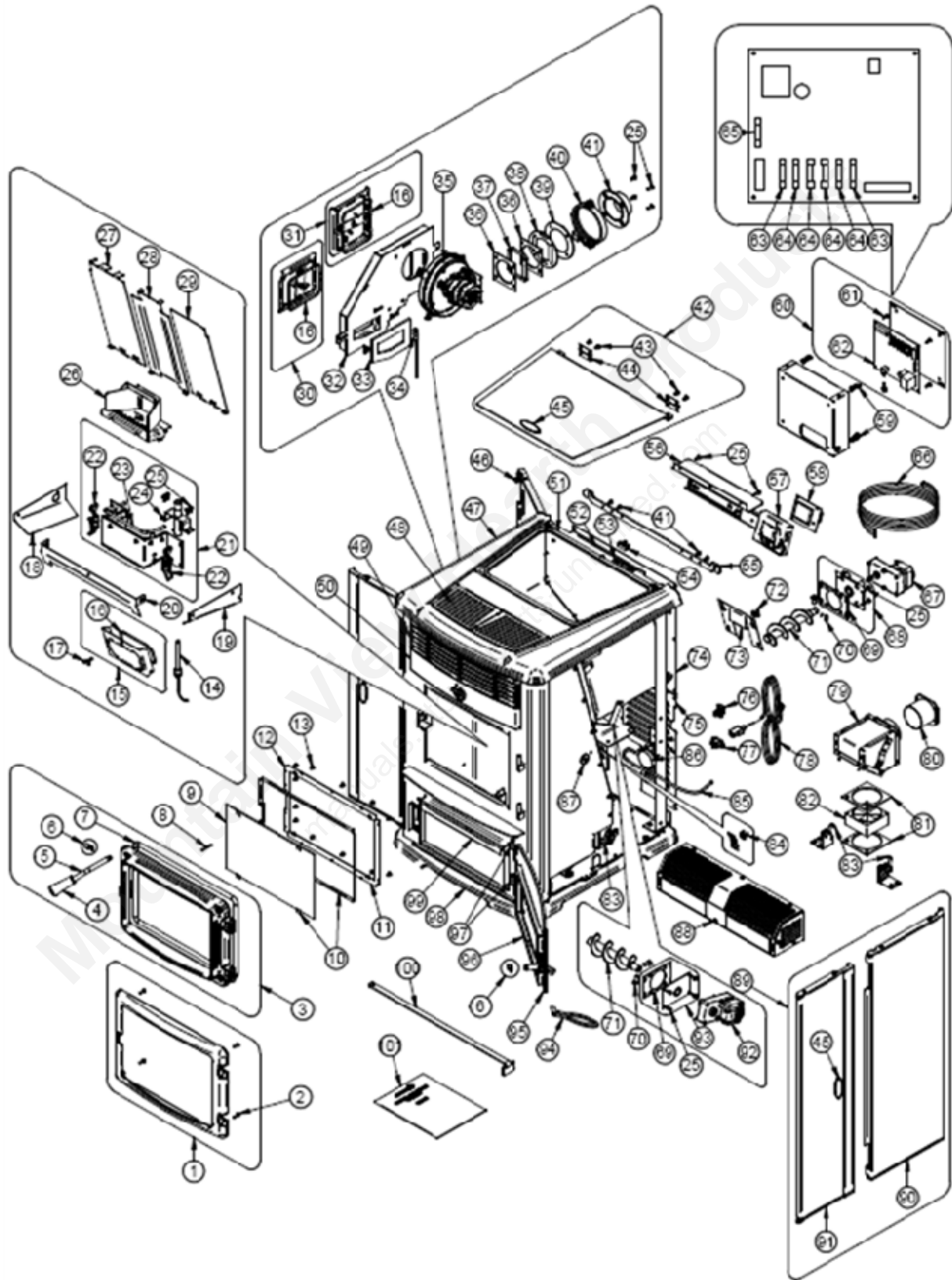

**IMPORTANT:** THIS IS DATED INFORMATION. When requesting service or replacement parts for your stove, please provide the model number and the serial number. We reserve the right to change parts due to technology upgrade or availability. Contact an authorized dealer to obtain any of these parts. Never use substitute materials. Use of non-approved parts can result in poor performance and safety hazards.

#	Item	Description	Qty
1	AC01220	BLACK CAST IRON DOOR OVERLAY	1
1	AC01222	BRUSHED NICKEL CAST IRON DOOR OVERLAY	1
2	30123	SCREW #8 - 32 X 5/8" PAN QUADREX ZINC	4
3	SE24179-01	DOOR ASSEMBLY WITH HANDLE AND GASKET	1
4	30569	ROUND WOODEN HANDLE BLACK	1
5	PL62296	DOOR HANDLE	1
6	AC09185	DOOR LATCH KIT	2
7	AC06900	BLACK 1/2" ROUND X 9' GASKET KIT WITH ADHESIVE	1
8	30101	SPRING TENSION PIN 5/32" DIA X 1 1/2" LONG	1
9	PL62418	REPLACEMENT GLASS 9 11/64" X 14 11/16"	1
10	AC06810	GASKET KIT SELF ADHESIVE BLACK 1/8" X 3/8"	1
11	PL64472	HINGE SIDE GLASS RETAINER	1
12	PL64473	HANDLE SIDE GLASS RETAINER	1
13	30124	SCREW #8 - 32 X 5/16" TRUSS QUADREX ZINC	12
14	SE44132	PELLET IGNITER ASSEMBLY 120 V	1
15	SE64289	BURN POT RECEPTACLE MAINTENANCE ACCESS DOOR	1
16	AC06815	GASKET KIT SELF ROUND BLACK 3/16"	1
17	30485	WING NUT 1/4-20 X 1/2" ZINC	1
18	PL64276	LEFT ASH DEFLECTOR	1
19	PL64277	RIGHT ASH DEFLECTOR	1
20	PL64290	FRONT ASH DEFLECTOR	1
21	SE64309	BURN POT RECEPTACLE	2
22	30686	FIRE POT LATCH	2
23	AC06300	ROUND GASKET AND SILICONE KIT 5/16" X 6.6'	1
24	44146	IGNITER TUBE	1
25	30026	THREAD CUTTING SCREW 10-24 F 5/8" HEX WASHER HEAD	14
26	SE64313	BURN POT	1
27	PL64264	LEFT BAFFLE	1
28	PL64458	MIDDLE BAFFLE	1
29	PL64252	RIGHT BAFFLE	1
30	SE64379	EXHAUST BLOWER MAINTENANCE ACCESS DOOR	1
31	SE64378	EXHAUST CHANNEL MAINTENANCE ACCESS DOOR	1
32	SE64375	EXHAUST CHANEL ASSEMBLY	1
33	21384	EXHAUST GASKET	1
34	44095	THERMISTOR	1

#	Item	Description	Qty
35	SE44144	EXHAUST FAN ASSEMBLY	1
36	21382	OUTLET EXHAUST BLOWER GASKET	2
37	PL64462	BLOWER OUTLET SPACER	1
38	PL64463	ROUND EXHAUST PLATE	1
39	21392	EXHAUST ADAPTER GASKET	1
40	30762	VENT ADAPTER SECURE CLAMP	1
41	SE64345	VENT ADAPTER	1
42	SE64493	HOPPER LID	1
43	30029	CUTTING THREAD SCREW 10-24 TYPE "F" X 3/8" HEX WASHER	10
44	30013	HINGE 2" X 1-1/2"	2
45	30693	HOPPER LID HANDLE	3
46	30757	RUBBER BUMPER	4
47	24229	CAST IRON TOP	1
48	SE64394	TOP GRILL	1
49	24177	CAST IRON UPPER GRILLE EUROZONE 35(DRILL & TAP)	1
50	SE62334	FRONT DECORATIVE PANEL	1
51	AC06820	EPDM GASKET KIT 4.5 FT	1
52	99999	BUILD TO ORDER	1
53	99999	BUILD TO ORDER	1
54	44098	HOPPER LID SAFETY SWITCH	1
55	PL64490	HOPPER LID SUPPORT	1
56	SE62421	LCD BRACKET	1
57	SE64358	LCD WITH HOUSING	1
58	PL64358	EUROSTAR TOUCH SCREEN ELECTRONIC BOARD (LCD)	1
59	30710	SPRING CLIP	4
60	SE64459	PC BOARD WITH HOUSING	1
61	30408	ELECTRONIC BOARD CLIP	4
62	PL64357	MOTHER BOARD 6 OUPUT	1
63	44015	FUSE 5A / 250V / 1/4" DIA. X 1 1/4" LONG	2
64	44016	FUSE 3A / 250V / 1/4" DIA. X 1 1/4" LONG	4
65	44013	FUSE 7.5A / 250V / 1/4" DIA. X 1 1/4" LONG	1
66	60330	MAIN BOARD WIRE HARNESS	1
67	44106	GEAR MOTOR FOR PELLET STOVE 1.7 RPM	1
68	SE24233	GEAR MORTOR SUPPORT ASSEMBLY	1
69	21193	AUGER SUPPORT GASKET	2
70	30092	BOLT 5/16"-18 X 3/4" HEX GRADE 5	4
71	24017	CAST IRON AUGER	2
72	44059	THERMODISC 36T11 L250-25 AUTOMATIC	1
73	99999	BUILD TO ORDER	1
74	PL64337	TOP REAR PANEL	1

#	Item	Description	Qty
75	PL64259	BOTTOM REAR PANEL	1
76	60036	THERMOSTAT TERMINAL	1
77	60196	POWER CORD RECEPTACLE	1
78	60331	POWER CORD 6'	1
79	SE64363	COMBUSTION AIR INLET BOX	1
80	30761	PLASTIC BACKDRAFT DAMPER	1
81	21391	COMBUSTION BLOWER GASKET	2
82	SE44147	AXIAL BLOWER ASSEMBLY	1
83	30439	TENSION CLAMP	4
84	44058	THERMODISC 36T12 F160	1
85	49006	3/8" X 24" SILICONE HOSE	1
86	44029	PRESSURE SWITCH	1
87	30758	MAGNET IN STEEL RECEPTACLE	2
88	SE64373	DOUBLE CAGE BLOWER WITH HOUSING	1
89	AC01325	BLACK SIDE PANELS KIT - EUROSTAR	2
89	AC01326	CREME ENAMELED SIDE PANELS KIT - EUROSTAR	2
89	AC01327	RED ENAMELED SIDE PANELS KIT - EUROSTR	2
90	99999	BUILD TO ORDER	1
91	99999	BUILD TO ORDER	1
92	44038	AUGER GEAR MOTOR 1 RPM	1
93	SE64319	HOPPER AUGER SUPPORT WITH BUSHING AND GASKET	1
94	PL64439	REMOVABLE DRAWER HANDLE	1
95	SE24230	ASH DRAWER ACCESS DOOR WITH HANDLE AND GASKET	1
96	AC06725	GLUE & 3/4" WHITE GASKET KIT	1
97	30172	DOOR PIN 1/4" DIA X 1-1/4" LONG	2
98	24234	CAST IRON BASE	1
99	SE64320	ASH DRAWER	1
100	PL64498	SCRAPER	1
101	SE45546	EUROSTAR INSTRUCTION MANUAL KIT	1

# APPENDIX A: HORIZONTAL AND VERTICAL VENT CHART

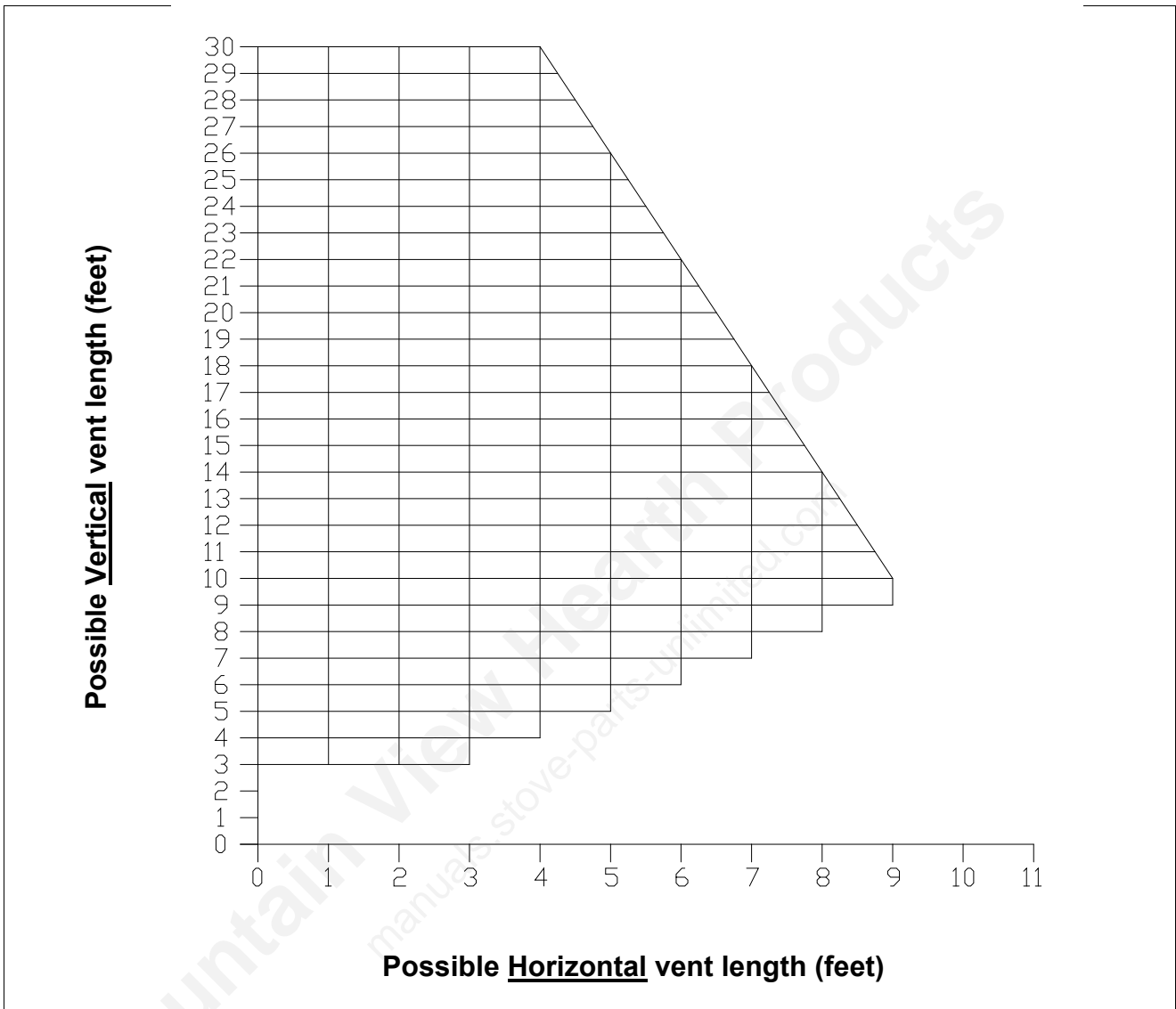

For example, let's imagine an installation consisting of a horizontal vent coming out at the back of the stove on a total distance of 8 feet. This horizontal run is followed by a tee and a 6-foot vertical rise. This type of installation is not acceptable. As you can see, the vent termination is clearly outside the allowed configuration zone on the chart because the venting system proposed **does not have at least one foot of vertical rise for each foot of horizontal run.**

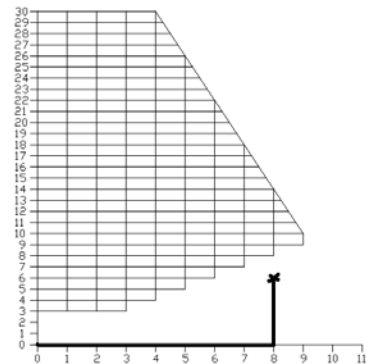

Instead, if the installation consisted of a horizontal vent coming out at the back of the stove on a total distance of 4 feet, followed by a tee and a 6-foot vertical rise, it would be acceptable. The installation end should be within the allowable configuration zone on the chart since it would have at least one foot of vertical rise for each foot of horizontal run. Furthermore, the total vertical rise would be at least 3-foot high.

**WARNING:** To reduce the risk of smoke spillage there should always be at least one foot of vertical rise for each foot of horizontal run. In all cases, at least 3 feet of vertical rise is needed.

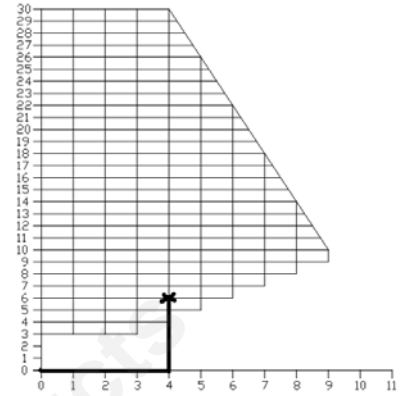

## APPENDIX B: LCD SLIDING BRACKET MOUNTING

### Step 1

The LCD sliding bracket is preassembled on the right hand side when facing the stove. To reverse the assembly to a left side configuration, extend the rail with the LCD support (E) in order to access the two screws (A) which secures the rail mechanism to the mounting bracket. Remove the screws, rotate the rail 180° and reassemble the rail to the mounting bracket using the screws previously removed.

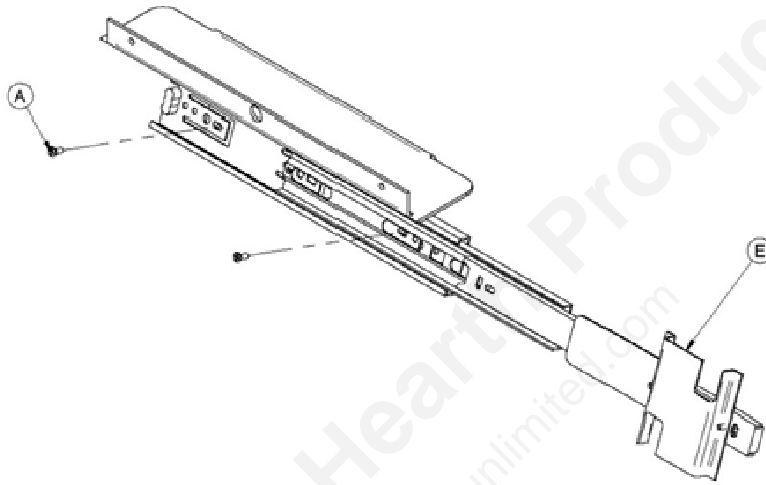

### Step 2

Remove the screws (C) located on the top edge of the back of the stove. Secure the mounting bracket (B) in place with the same screws.

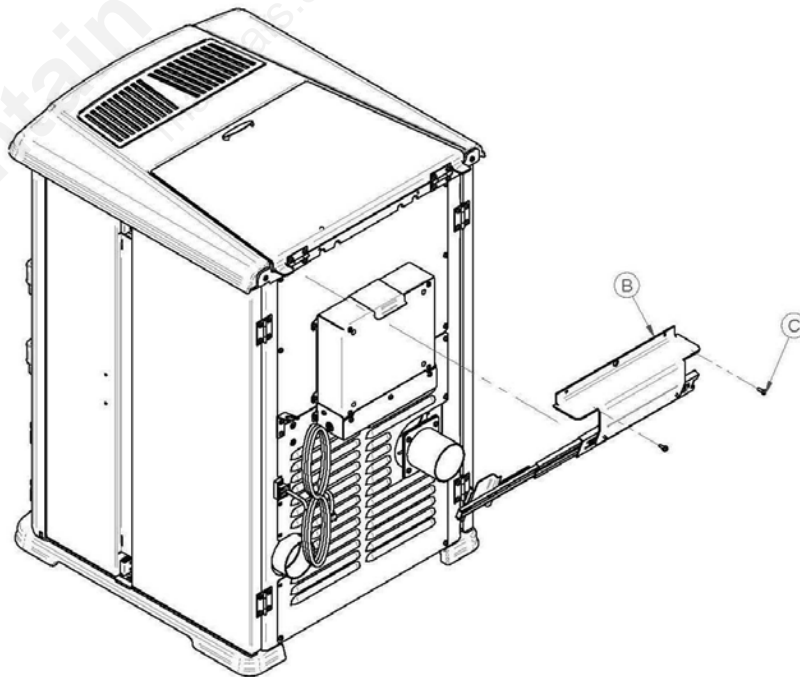

### Step 3

Take the Telco black wire (D) which is located on the rear bottom panel and plug it into the back of the LCD touch screen interface receptacle.

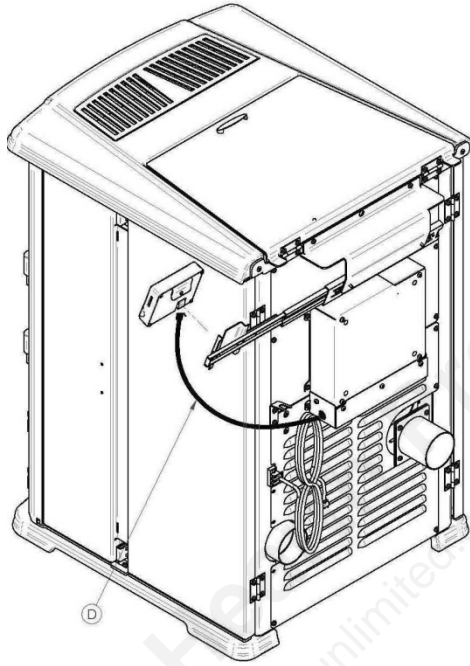

### Step 4

Finally, secure the LCD touch screen housing (F) on the rail (E).

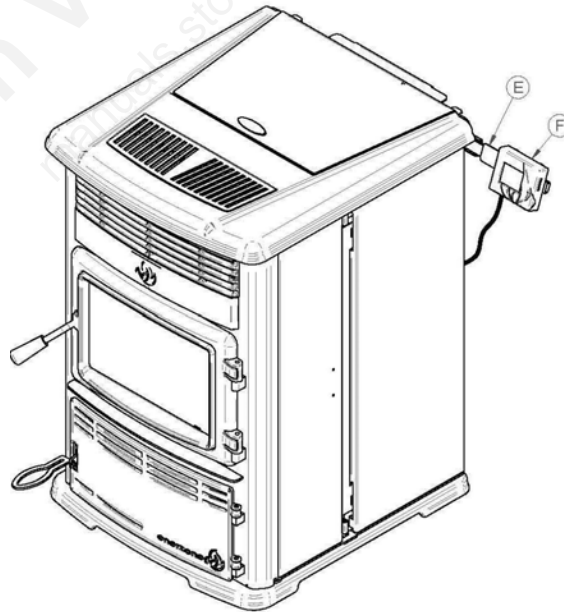

## APPENDIX C: FLAME CHARACTERISTICS

### Efficient flame

An efficient flame should be bright but not too vigorous. The flame should also have a yellow to bright look. There should also be some small embers or spark exiting the flame and burn pot. The following picture is the flame pattern that will produce optimum efficiency.



### Fire with too much air

A small blow torch flame as in the image below is a result of too much oxygen being supplied to the fire. This causes the flame to be very short with a bright yellow to almost white, flame look. This pattern does not allow optimum heat transfer to the exchanger therefore reduces convection efficiency. Depending on the quality of the pellets, there are usually more embers or sparks exiting the flame and burn pot. To rectify this condition, reduce combustion air flow to obtain a flame pattern as in the image above.



### **Fire with not enough air**

If the flame pattern is tall, lazy and orange with black smoky tips it is generally a result of insufficient air flow through the system. The possible causes are either a lack of oxygen to the fire, high moisture content pellet, obstructed channel or vent. This situation will lead to excessive black soot accumulation on the baffle and the glass. To rectify this condition, make sure the stove and the vent system is clean, the pellet being used is dry and increase combustion air flow if necessary.



## APPENDIX D: INSTALLING A THERMOSTAT

Using a thermostat will help you maintain a constant temperature throughout the house. A low voltage thermostat is required. A fixed wall mount or hand held model can be used.

**Note:** Thermostat manufacturer's instruction always overrides the information published in the following section.

### Thermostat location

Location of the thermostat is very important to obtain comfort and efficiency from your stove. Locate the thermostat 4 to 5 feet above the floor in accordance with applicable building codes. Install the thermostat in a location that provides good airflow characteristics and avoid areas behind doors, near corners, air vents, direct sunlight or heat generating devices. It should also be located at least 15 to 20 feet from the stove. To prevent cycling, you should avoid installing the thermostat on a poorly insulated outside wall or directly in front of the stove.

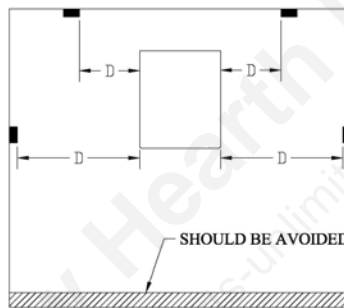

D = MINIMUM DISTANCE 15 FEET

### Wired thermostat

Before installing the thermostat, unplug the stove from the power outlet.

First, connect the two thermostat wires to the terminal block located at the rear on the right hand side of the stove while facing it. Loosen the two middle screws and insert the wires in the terminals. Tighten the two screws. Then, open the thermostat and connect the wires as per manufacturer's instructions.



Here is an example of what your thermostat could look like:

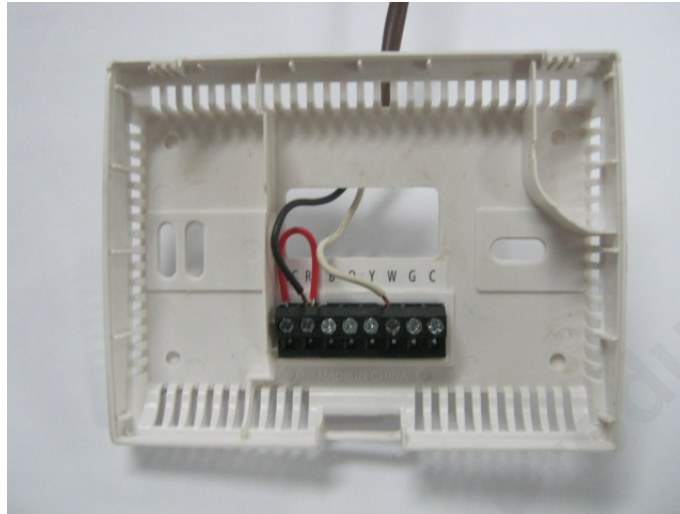

Connect one wire on “RH” and the other wire on “W”. Red wire jumper can be left installed. For further information refer to the manufacturer’s instructions.

### **Wireless thermostat**

If you are using a wireless thermostat or a hand held thermostatic remote control, connect the two thermostat wires to the terminal block located at the rear on the right hand side of the stove while facing it. If the receiver wires are equipped with quick-connect terminals you can connect them directly to the stove’s wiring harness.

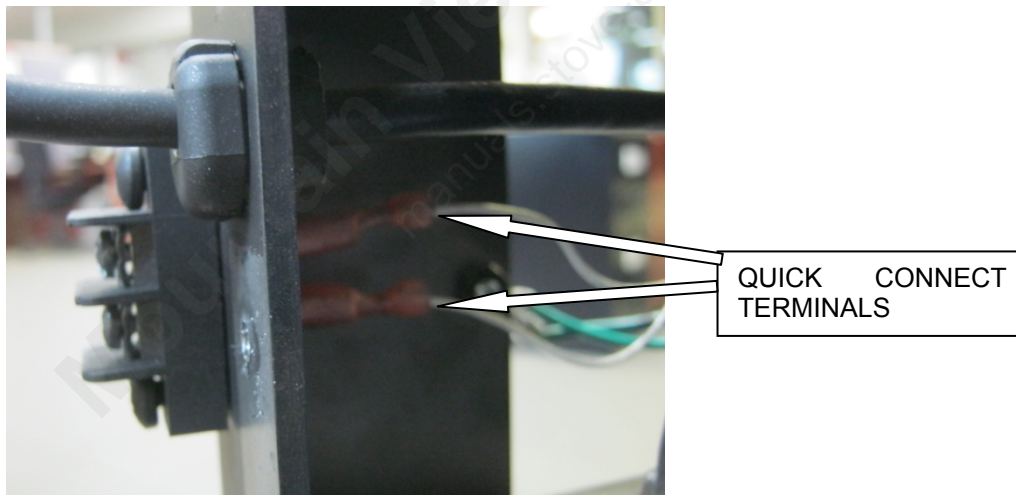

To do so, open the right hand side decorative panels and disconnect the two (2) harness wires attached to the rear of the terminal block and connect them to the receiver wires.

## APPENDIX E: MOBILE HOME INSTALLATION

### Anchor the stove

**WARNING: FOR MOBILE HOME INSTALLATION, IT IS MANDATORY TO CONNECT THE STOVE TO AN OUTSIDE COMBUSTION AIR SOURCE. (SEE APPENDIX F)**

When installed in a mobile home, the stove must be anchored to the floor with two screws. Use the two holes located for this purpose on each side of the pedestal, as shown on the following image.

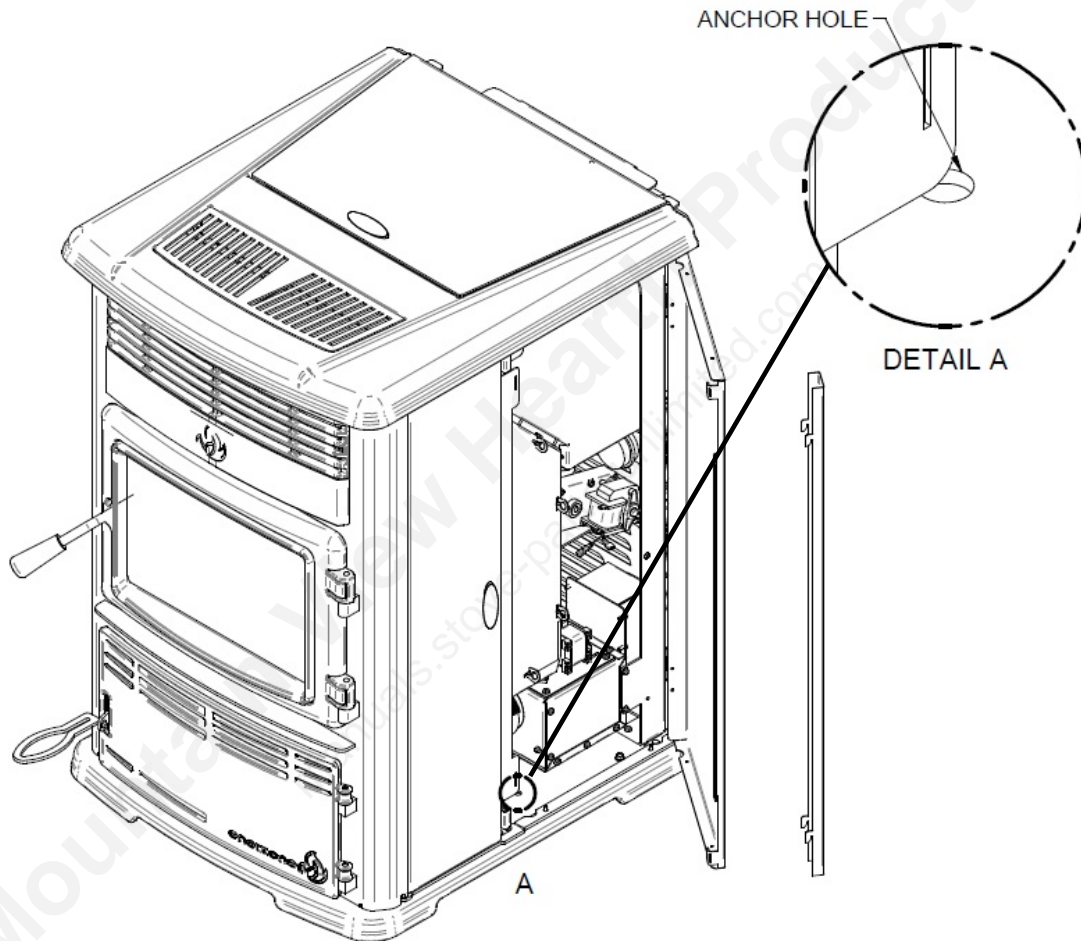

## APPENDIX F: COMBUSTION AIR SUPPLY

**WARNING:** FOR MOBILE HOME INSTALLATION, IT IS MANDATORY TO CONNECT THE STOVE TO AN OUTSIDE COMBUSTION AIR SOURCE. INSULATED PIPE SHOULD NEVER EXCEED 10 FEET.

It is recommended to install an outside air inlet in or near the room where the stove is installed. When doing so, it is preferable to choose a wall which is not exposed to dominant winds, depending on the conditions surrounding your house.

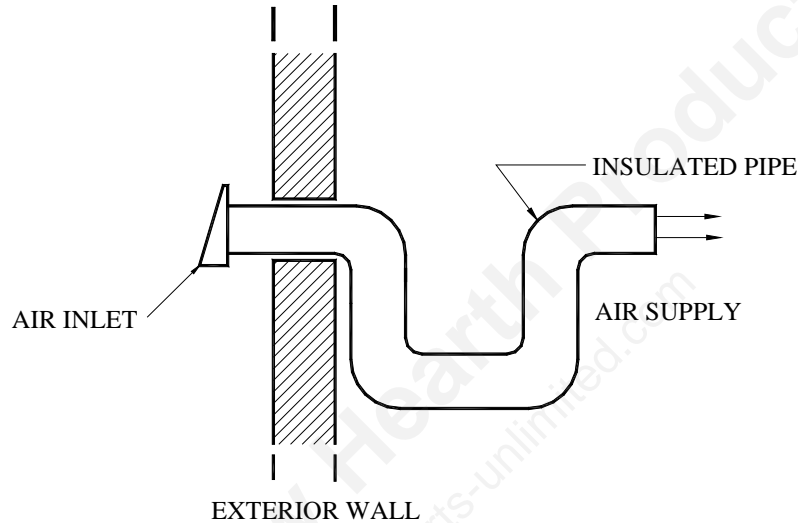

An insulated 3" inside diameter metallic pipe, either flexible or rigid, must be attached to the fresh air intake (A).

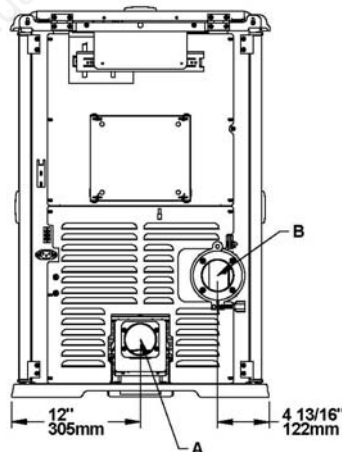

A: FRESH AIR INTAKE

B: EXHAUST

A rodent guard (minimum 1/4" wire mesh) must be used at the termination. All connections must be secured and airtight by either using the appropriately sized hose clamp and/or UL-181-AP foil tape.

Also make sure that the fresh air intake backdraft shutter (A) works freely. The fresh air intake backdraft shutter is located at the middle of the stove's right hand side.

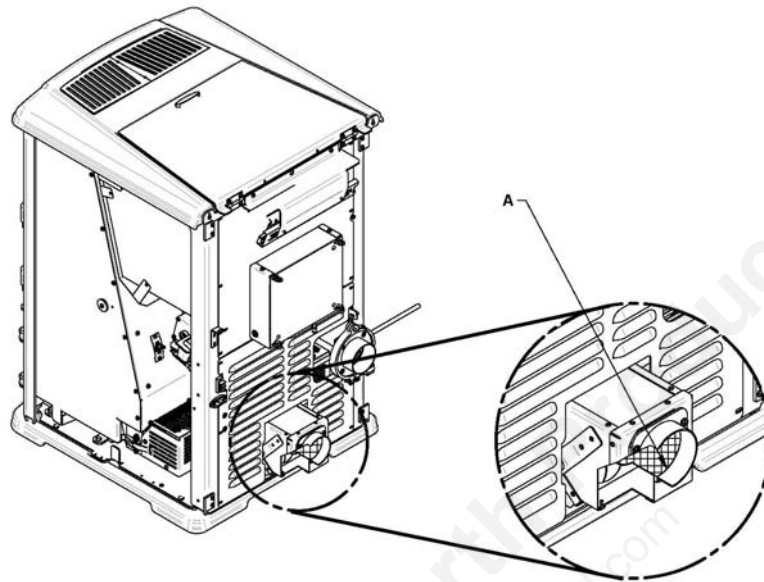

### **Sources of Outside Combustion Air**

- You can draw air from a ventilated crawl space underneath the floor.
- You can draw air directly from an outside wall, behind the stove.

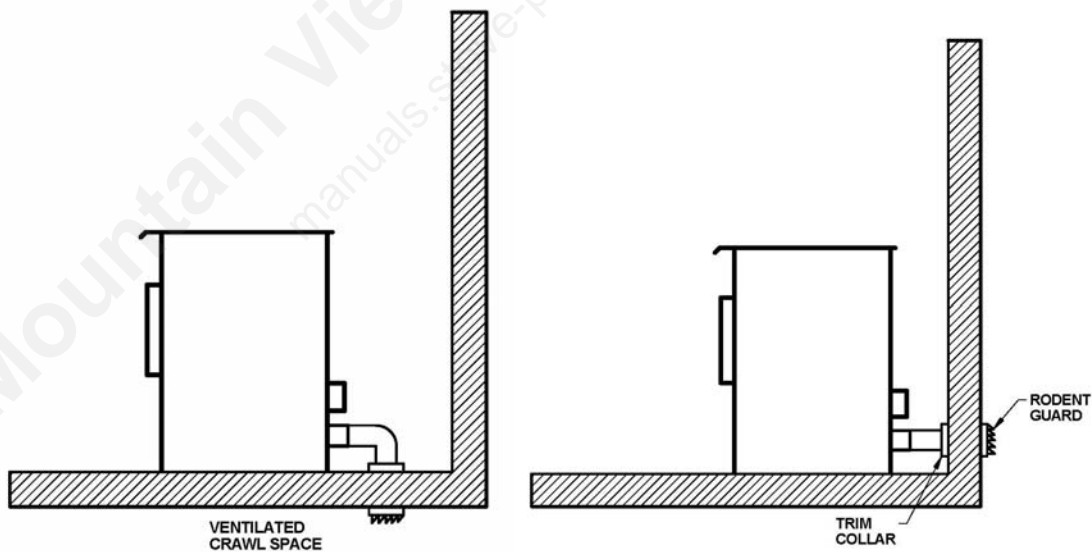

**NOTE:** The stove exhaust blower produces a negative pressure in the room. It draws air from the inside to the outside. In the same way, other appliances can also create a bigger negative pressure. In this case, as the air naturally flows from high pressure point to low pressure point, the bigger negative pressure may draw the smoke from the inside of the stove into the room. The stove can also affect other ventilation appliances, causing the same effect to them. Using a fresh air intake will prevent negative pressure.

## ENERZONE LIMITED LIFETIME WARRANTY

The warranty of the manufacturer extends only to the original consumer purchaser and is not transferable. This warranty covers brand new products only, which have not been altered, modified nor repaired since shipment from factory. Proof of purchase (dated bill of sale), model name and serial number must be supplied when making any warranty claim to your ENERZONE dealer.

**This warranty applies to normal residential use only. Damages caused by misuse, abuse, improper installation, lack of maintenance, over firing, negligence or accident during transportation, power failures, downdrafts, or venting problems are not covered by this warranty.**

This warranty does not cover any scratch, corrosion, distortion, or discoloration. Any defect or damage caused by the use of unauthorized parts or others than original parts void this warranty. An authorized qualified technician must perform the installation in accordance with the instructions supplied with this product and all local and national building codes. Any service call related to an improper installation is not covered by this warranty.

The manufacturer may require that defective products be returned or that digital pictures be provided to support the claim. Returned products are to be shipped prepaid to the manufacturer for investigation. If a product is found to be defective, the manufacturer will repair or replace such defect. Transportation fees to ship the product back to the purchaser will be paid by the manufacturer. Repair work covered by the warranty, executed at the purchaser's domicile by an authorized qualified technician requires the prior approval of the manufacturer. Labour cost and repair work to the account of the manufacturer are based on predetermined rate schedule and must not exceed the wholesale price of the replacement part. All parts and labour costs covered by this warranty are limited according to the table below.

The manufacturer at its discretion may decide to repair or replace any part or unit after inspection and investigation of the defect. The manufacturer may, at its discretion, fully discharge all obligations with respect to this warranty by refunding the wholesale price of any warranted but defective parts. The manufacturer shall in no event be responsible for any special, indirect, consequential damages of any nature, which are in excess of the original purchase price of the product. A one-time replacement limit applies to all parts benefiting from a lifetime coverage. This warranty applies to products purchased after October 1<sup>st</sup>, 2011.

DESCRIPTION	WARRANTY APPLICATION	
	PARTS	LABOUR
Combustion chamber (welds only), castings, heat exchanger (welds only), auger, and ceramic glass (thermal breakage only*).	Lifetime	4 years
Plating* (defective manufacture) – subject to limitations above.	Lifetime	n/a
Stainless steel firebox components, surrounds and heat shields, ash drawer, pedestal, and trims (aluminum extrusions).	5 years	3 years
Carbon steel firebox components, burn pot, glass retainers, and handle assembly.	3 years	2 years
Blowers, ignitor, PC board, auger motor, heat sensors, switches, wiring, rheostat, and other controls.	2 years	1 year
Paint (peeling), gaskets, insulation, ceramic logs, masonry-like panels, and ceramic fibre blankets.	1 year	n/a

*\*Pictures required*

Shall your unit or a components be defective, contact immediately your **ENERZONE** dealer. Prior to your call make sure you have the following information necessary to your warranty claim treatment:

- Your name, address and telephone number;
- Bill of sale and dealer's name;
- Serial number and model name as indicated on the nameplate fixed to the back of your unit;
- Nature of the defect and any relevant information.

**Before shipping your unit or defective component to our plant, you must obtain from your ENERZONE dealer an Authorization Number. Any merchandise shipped to our plant without authorization will be refused automatically and returned to sender.**