

**SHERWOOD**
INDUSTRIES LTD.

FOR INSTALLERS AND SERVICE TECHNICIANS ONLY



**PELLET
STOVE
SERVICE
MANUAL**

Sherwood Industries Ltd. Duplication of this document is prohibited. All rights reserved.

August 2003

C-10097

This is a service guide designed by SHERWOOD INDUSTRIES LTD.
 We hope this manual will assist you to identify and correct operational concerns you might experience in all ENVIROFIRE pellet stoves.
 This service guide is designed for SERVICE TECHNICIANS AND INSTALLERS ONLY.
 This guide is not to be used by the homeowner.
 If after using this service manual and following our recommendations and the problem still exists, please do not hesitate to call our technical department.

Technical Division
 Sherwood Industries Ltd.

TABLE OF CONTENTS

PAGE

Timer Control.....	1
1) STOVE WILL NOT START.....	1
2) STOVE WILL NOT OPERATE WHEN HOT.....	2
3) THE COMBUSTION (EXHAUST) BLOWER WILL NOT FUNCTION.....	2
4) THE CONVECTION BLOWER WILL NOT FUNCTION PROPERLY.....	3
5) THE AUGER MOTOR DOES NOT FUNCTION PROPERLY.....	5
6) DIAL-A-FIRE HAS NO EFFECT ON THE FIRE.....	8
7) THE STOVE WILL NOT SHUT DOWN.....	9
CIRCUIT BOARD.....	10
1) MANUAL MODE, FACTORY SETTINGS, NO THERMOSTAT OR WALL SWITCH....	10
2) HI/LO MODE, WITH THERMOSTAT OR WALL SWITCH.....	11
3) ON/OFF MODE, WITH THERMOSTAT OR WALL SWITCH.....	13
CIRCUIT BOARD CONTROLS.....	16
THERMOSTAT PIN SET-UP.....	16
1) LIGHT #2 ON HEAT OUTPUT BAR FLASHING.....	17
2) LIGHT #3 ON HEAT OUTPUT BAR FLASHING.....	18
3) AUGER LIGHT FLASHES BUT AUGER MOTOR DOES NOT TURN AT ALL.....	21
GENERAL.....	22
1) THE IGNITOR DOES NOT WORK.....	22
2) THE STOVE KEEPS GOING OUT.....	23
COMPONENTS OF A PELLET STOVE.....	24
FLAME CHARACTERISTICS.....	26
WIRING DIAGRAMS.....	27
GLOSSARY.....	36

SUGGESTED TOOLS LIST

Cordless drill / Screwdriver	Magnehelic Pressure Gauge
Multimeter	Ratchet and Sockets: 1/4" to 5/8"
Open ended Wrenches: 1/4" to 1/2"	Electrical Tape
Screwdrivers (T20 TORX) Robertson, Straight Blade	
Wire Cutters, Strippers, Crimpers and Needle Nose Pliers	
Penetrating Lubricant (WD-40)	
High Temperature Silicone (RTV) 500°F	
1/4" Insulated connectors	

DIAL-A-FIRE
1) STOVE WILL NOT START

Make sure that the stove is plugged in and the receptacle is supplying power.

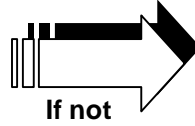

Plug the unit in or fix receptacle if necessary.

Push the start up switch.

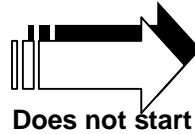

Check all wiring for damage and that all the wiring is correct against the wiring diagram.

EF 2

Attempt to bypass the auto/manual switch with a jumper wire between the grey and black wires.

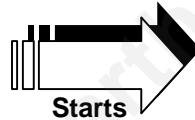

Replace the switch.

EF 3, 4, 5

Attempt to by pass the start up switch with a jumper wire between the red and white wires. Plug the stove back into wall outlet.

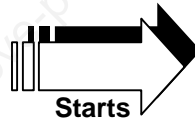

Replace the switch.



Replace the start up timer.

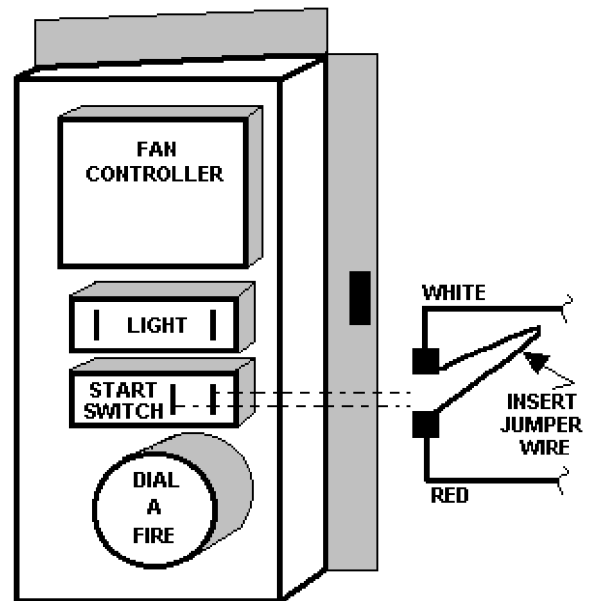

2) STOVE WILL NOT OPERATE WHEN HOT

Unplug the stove; place a jumper wire across the two brown wires on the exhaust temperature sensor. Plug unit back in.

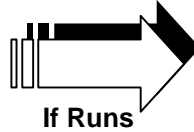

Replace the sensor if necessary.

EF-2--120°F (49°C)

EF-3--140°F (60°C)

EF-4--120°F (49°C)

EF-5--120°F (49°C)

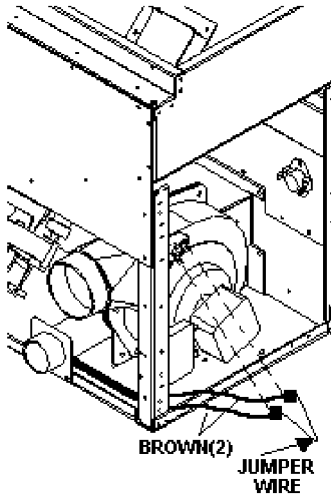

EF-2

By pass the auto side of the switch with a jumper wire. Plug the unit back in, if it starts replace the switch.

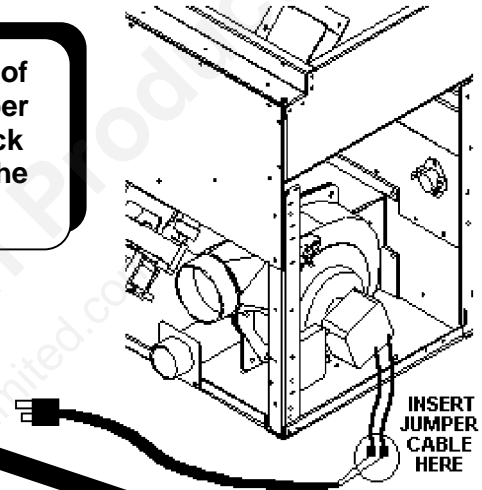

3) THE COMBUSTION (EXHAUST) BLOWER WILL NOT FUNCTION

Open the left side panel, check all connections and wiring against the wiring diagram.

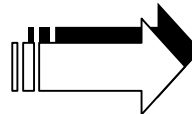

Correct if necessary.

Tap motor housing lightly this may loosen a tight motor.

Apply direct power to the exhaust blower with a test cord, by removing the two leads and plugging the motor in directly.

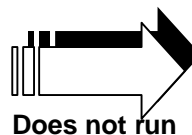

Replace the blower motor.

EF-4, 5

Replace the phase controller.

**4) THE CONVECTION
BLOWER WILL NOT
FUNCTION PROPERLY**

Check all the wires
against the wiring
diagram.

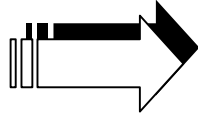

Correct if necessary.

Apply direct power to the
convection blower with a
test cord.
See next page.

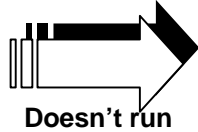

Replace the blower.

If the convection blower
runs on high all the time.

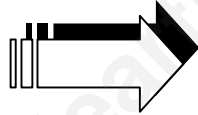

Remove one of the wires
from the 160 °F (71°C)
temperature sensor.

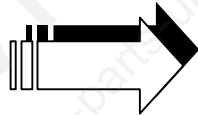
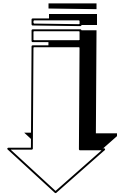

If the blower shuts off
replace the 160° F (71°C)
fan temperature sensor.

If the motor is still running
on high, replace the fan
controller.

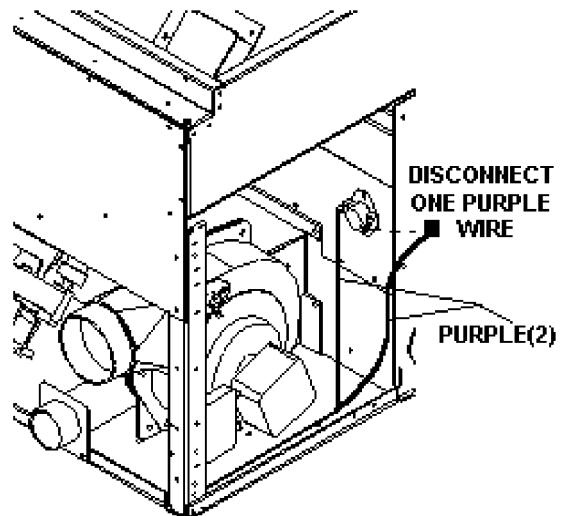

If the fan has a low pitched
rumble.

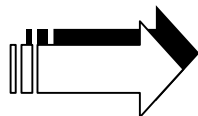

Replace the fan controller.

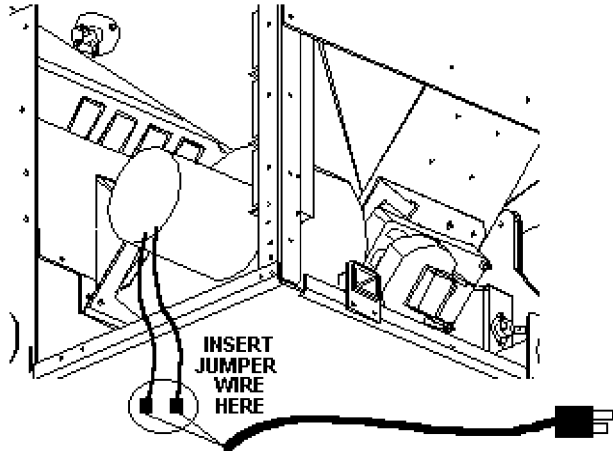

Applying direct power to the convection blower.

Bypassing the 200°F 93°C manual reset temperature sensor.

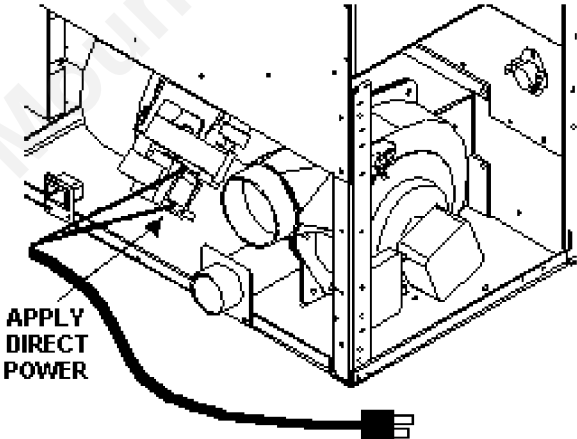
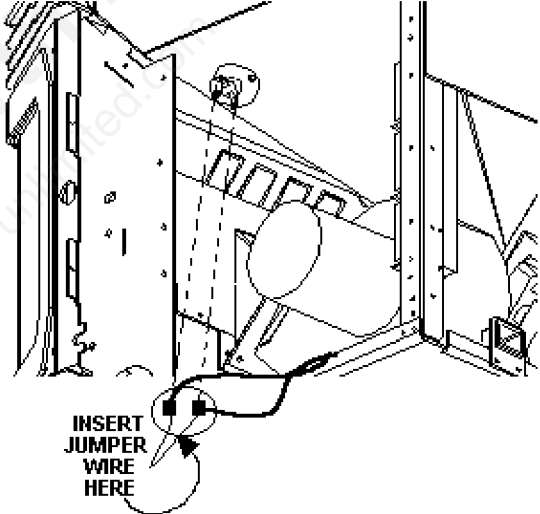

Applying direct power to the auger motor.

**5) THE AUGER MOTOR
DOES NOT FUNCTION
PROPERLY**

Make sure that the exhaust blower is operating correctly.

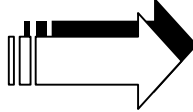

If NO see section #3 in this manual.

Make sure the dial-a-fire is turned to the "ON" position.

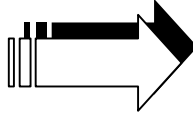

Turn knob clockwise to the "ON" position.

Check to make sure all wires are correct to the auger motor, dial-a-fire, vacuum sensor, 200°F (93°C) temperature sensor and the timing control module.



Correct if necessary.

Using a test cord apply direct power to the auger motor. See previous page.



Replace the auger motor.

Doesn't run

Check the vacuum hose to make sure there are no cracks or breaks.

Check to make sure that the reset button on the 200° F (93°C) temperature has not been tripped.

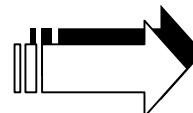

IF THIS SENSOR HAS BEEN TRIPPED FIND THE REASONS FOR THE OVER HEATING **BEFORE PUSHING BUTTON IN.**

By pass the 200° F (93°C) temperature sensor with a jumper wire. See previous page.

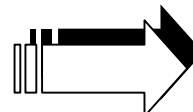

Replace the 200° F (93°C) temperature sensor.

If it works

CONTINUED ON NEXT PAGE

AUGER MOTOR DOES NOT FUNCTION PROPERLY
CONTINUED

Check the vacuum switch by placing a jumper wire between the two blue leads from the vacuum switch.

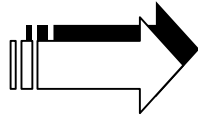

If the auger motor works make sure the exhaust motor is producing enough vacuum.

Using a Magnehelic pressure gauge, disconnect the vacuum hose from the exhaust channel, these reading should be greater than:
0.4" wc (EF 2-3).
0.2" wc (EF-4).

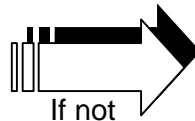
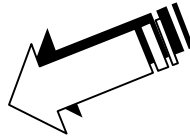

The unit may require a thorough cleaning. If thoroughly cleaned. Replace the combustion exhaust blower.

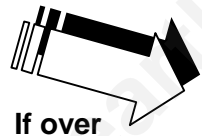

Replace the vacuum sensor.

Test the dial-a-fire; place a jumper wire across the (2) two pins on the timing control module

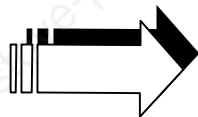

If the auger motor cycles very quickly, test the dial-a-fire.

Using a multimeter test the dial-a-fire, the values from this test should be between 68k and 850k plus or minus 10%.

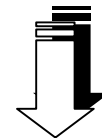

Replace the Dial A Fire.

If all these procedures are O.K. replace the auger-timing module

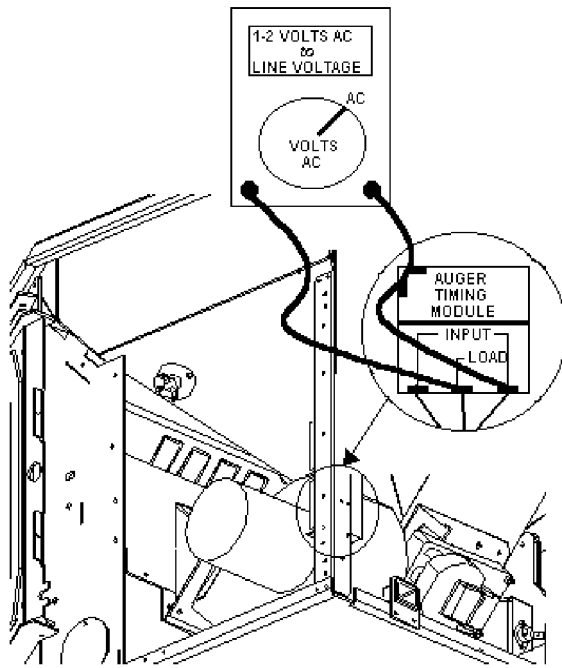

Checking the auger timing control module.

Bypassing the vacuum switch.

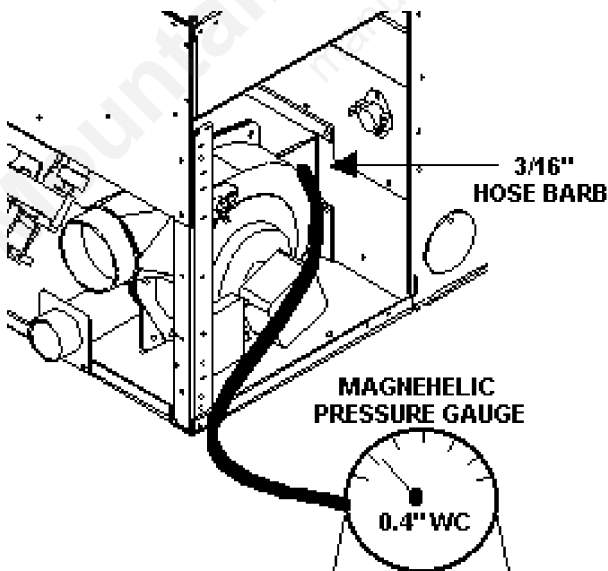
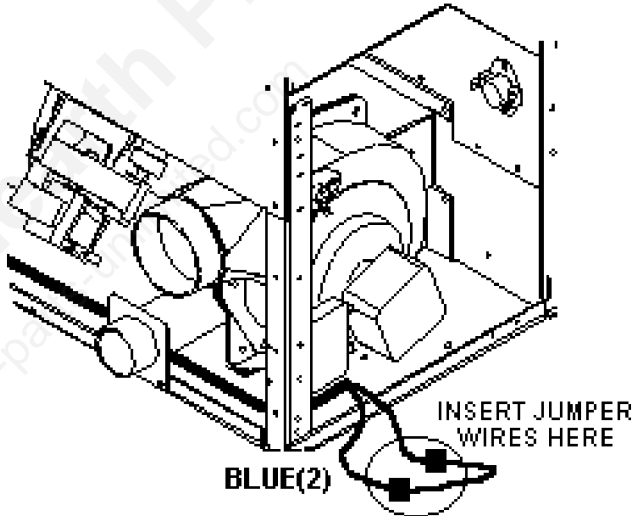

Testing the exhaust vacuum.

6) DIAL-A- FIRE HAS NO EFFECT ON THE FIRE

Test the dial-a-fire potentiometer resistance by placing the multimeter leads into the leads of the potentiometer. Remove leads from the timing control.

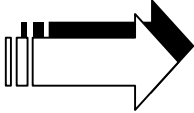

EF 2, 3, 5
Low fire 800-900k ohms.
High fire 71-73k ohms.

EF 4
Low-Fire 800-900k ohms.
High fire 36.5k ohms.

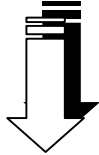

Replace the potentiometer or dial-a-fire.

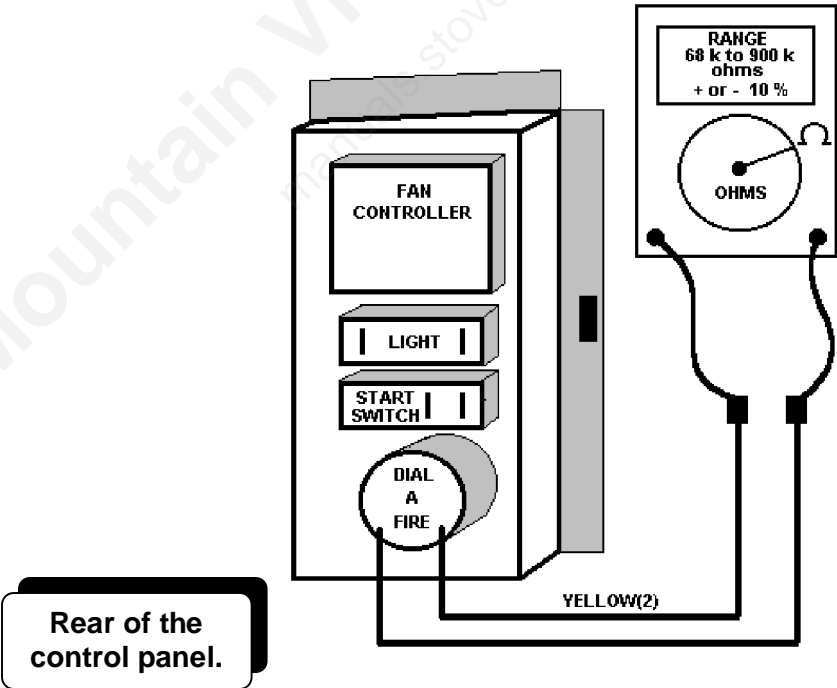

Mountain View Hearth Products | manuals.stove-parts-unlimited.com

7) THE STOVE WILL NOT SHUT DOWN

Check all wiring to the exhaust temperature sensor, start-up switch and the start up timer.

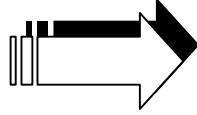

Correct if necessary.

EF 3, 4, 5

Disconnect one brown wire from the exhaust temperature sensor.

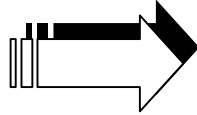

If the unit shuts down, replace the exhaust temperature sensor.

If the unit does not shut down test the switch.

The unit must be cold, unplug the unit and then plug it back in.

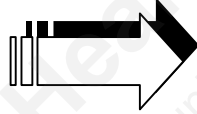

If the unit starts without pushing the start up switch, test the 15 minutes start up timer.

Open the right hand side panel. Remove the red wire from the 15 minute start up timer, unplug the unit and then plug the stove back in.

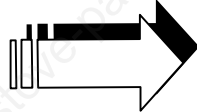

If the unit does not start replace the switch.

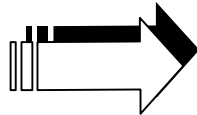

If the unit starts by itself replace the (15) fifteen minute timer.

EF-2

With one of the brown wires from the exhaust temperature sensor disconnected.

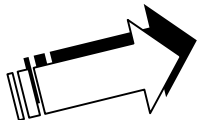

If the unit shuts down replace the auto/manual switch.

EF-2

Remove the gray wire from the auto/ manual switch.

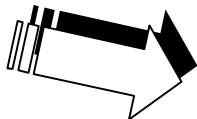

If the unit did not shut down replace the wiring harness.

CIRCUIT BOARD

OPERATION

1) Manual Mode, Factory Settings, No Thermostat or Wall Switch

START-UP SEQUENCE (15 minutes)

Push the ON/OFF button to start.

The ON/OFF light turns on solid.

The ON/OFF lights starts to flash after the vacuum sensor has closed (approx. 15 seconds).

Auger light flashes:

- 3 seconds ON.

- 8 seconds OFF.

The combustion blower comes on at full speed.

The ignitor comes on.

The convection blower stays off.

The operator has no control over the start-up sequence. (The operator can press and hold the manual feed button to run the auger continuously. The operator can also pre-set the heat output setting for operation. When the unit reaches operating temperature the heat output will go to that setting.)

The unit should light after 5 to 12 minutes.

Once the 120 °F (49 °C) exhaust temperature sensor closes, the Convection blower will come on.

15 minutes after pushing the start button, the On/Off light changes to solid. This signals that the unit is at operating temperature.

Normal Operation

The operator can now set the heat output, low feed trim and whether the convection blower is ON or OFF. (Please note: when the heat output is changed, the combustion blower and convection blower speed change as well.)

Shut Down

Push the ON/OFF button to turn stove off.

All the lights will turn off.

The auger will stop feeding.

The combustion blower goes to full speed until the exhaust temperature sensor opens, stopping all motors

2) HI/LOW Mode, With Thermostat or Wall Switch

START-UP SEQUENCE

(15 minutes)

Thermostat contacts closed at time of start-up.

Push the ON/OFF button to start.

The ON/OFF light turns on solid.

The ON/OFF lights starts to flash after the vacuum sensor has closed (approx. 15 seconds).

Auger light flashes:

- 3 seconds ON.

- 8 seconds OFF.

The combustion blower comes on at full speed.

START-UP SEQUENCE CONT.

The ignitor comes on.

The convection blower stays off.

The operator has no control over the start-up sequence. (The operator can press and hold the manual feed button to run the auger continuously. The operator can also pre-set the heat output setting for operation. When the unit reaches operating temperature the heat output will go to that setting.)

The unit should light after 5 to 12 minutes.

Once the 120 °F (49 °C) exhaust temperature sensor closes, the convection blower will come on.

15 minutes after pushing the start button, the On/Off light changes to solid. This signals that the unit is at operating temperature.

Note: The circuit board can only be turned OFF during start-up if vacuum has been established and the thermostat contacts are closed. The ON/OFF light will continue flashing

START-UP SEQUENCE (15 minutes)

Thermostat contacts open at time of start-up.

**Same as "START-UP SEQUENCE (15 minutes)
Thermostat contacts closed at time of start-up."**

NORMAL OPERATION Thermostat contacts are closed.

The ON/OFF light is solid.

Operator can now set; heat output, low feed trim and convection blower ON/OFF (combustion blower, convection blower and heat output all change together.)

NORMAL OPERATION
Thermostat contacts are open.

The ON/OFF light starts flashing.

All functions drop to LOW speed (combustion blower speed, convection blower speed and heat output all change to LOW together.)

Operator has no control over the heat output, but can control the low feed trim and convection blower ON/OFF.

SHUT DOWN
Thermostat contacts are closed.

Push ON/OFF button to turn stove off.

All lights turn off.

Auger stops feeding.

Combustion blower goes to full speed until exhaust sensor opens and blower stops.

SHUT DOWN
Thermostat contacts are open.

Push ON/OFF button to turn stove off.

The ON/OFF light continues to flash.

Auger stops feeding.

Combustion blower goes to full speed until exhaust sensor opens and blower stops.

The ON/OFF light will continue to flash (unless power is disconnected).

**3) ON/OFF Mode, With Thermostat or
Wall Switch**

**START-UP SEQUENCE
(15 minutes)**

Thermostat contacts closed at time of start-up.

Push the ON/OFF button to start.

The ON/OFF light turns on solid.

The ON/OFF lights starts to flash after the vacuum sensor has closed (approx. 15 seconds).

Auger light flashes:

- 3 seconds ON.

- 8 seconds OFF.

The combustion blower comes on at full speed.

The ignitor comes on.

The convection blower stays off.

The operator has no control over the start-up sequence. (The operator can press and hold the manual feed button to run the auger continuously. The operator can also pre-set the heat output setting for operation. When the unit reaches operating temperature the heat output will go to that setting.)

The unit should light after 5 to 12 minutes.

Once the 120 °F (49 °C) exhaust temperature sensor closes, the convection blower will come on.

15 minutes after pushing the start button, the On/Off light changes to solid. This signals that the unit is at operating temperature.

If the thermostat contacts are opened during start up the circuit board and all motors turn OFF and the ON/OFF light remains flashing.

**START-UP SEQUENCE
(15 minutes)**

Thermostat contacts open when the ON/OFF button is pushed.

The circuit board will not turn on.

NORMAL OPERATION
Thermostat contacts are closed.

Unit starts the start-up sequence.

After 15 minutes start-up, operator can set; heat output, low feed trim and convection blower ON/OFF (combustion blower, convection blower and heat output all change together).

NORMAL OPERATION
Thermostat contacts are open.

Unit shuts down.

SHUT DOWN
Thermostat contacts are closed.

Stove will not shut off.

If you push ON/OFF button the circuit board will go through a start-up sequence (see start-up section above).

SHUT DOWN
Thermostat contacts are open.

All lights turn off.

Auger stops feeding.

Combustion blower goes to full speed until exhaust sensor opens and blower stops.

CIRCUIT BOARD CONTROLS

HEAT LEVEL (OUTPUT) LIGHTS – shows the heat setting that the stove is operating in. lowest setting is at the bottom.

HEAT LEVEL SWITCH – press this button to set the heat level. The light will scale up through the range then back to the lowest.

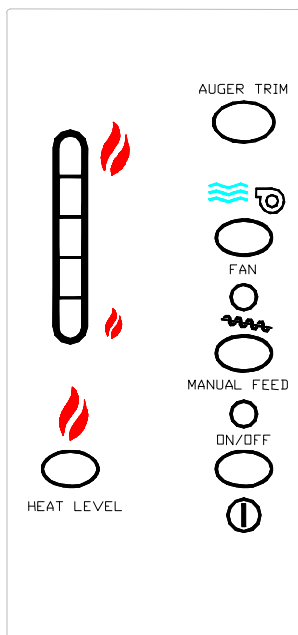

AUGER TRIM SWITCH – Press this button to choose between three different ON times when the heat output in the low setting. Only the bottom heat level light on shows that the on time is set at 3 seconds ON (factory setting). Push the switch and the lights change to the bottom and the top light being on, this means the auger ON time has been increased to 4 seconds. Push the button again and the lights change to the bottom and the second from the top position. The auger ON time is now 2 seconds.

CONVECTION FAN SWITCH – press this switch to turn the convection blower OFF, press again to turn the blower on to the preset speed that corresponds to the heat level.

MANUAL FEED SWITCH – hold this button down to manually run the auger continuously. The auger returns to automatic when the switch is released.

ON/OFF SWITCH – push this switch to start or stop the unit when the unit is operating in “manual” or HI/LOW thermostat mode (ON/OFF is automatic once the stove has been started once).

THERMOSTAT PIN SET-UP

CAUTION: The use of the thermostats with timers may result in the unit shutting off during start-up. This may allow smoke to enter the house through the air wash system.

Jumper pins J9
the HI / LOW
mode

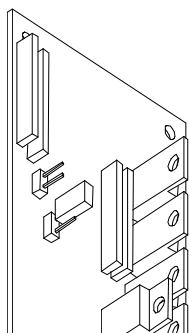

Jumper pins
in the ON /
OFF mode

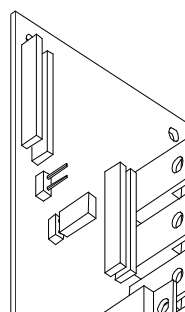

CIRCUIT BOARD
1) LIGHT #2 ON HEAT
OUTPUT BAR FLASHING

If light #2 on the heat output bar is flashing, the vacuum switch contacts have been open for more than 15 seconds.

Possible causes:

Pinch, break or blockage in vacuum hose.

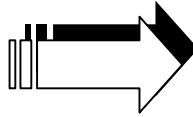

Check hose for pinch points or damage. Replace or re-route as required, blow out vacuum hose.

Blocked hose barb on exhaust channel.

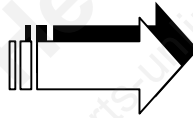

Use a paper clip to clean out hose barb or remove the vacuum hose from the vacuum switch and blow into the hose to remove blockage. *To prevent further build up install, the Windsor Hose Barb Shield (part# 50-472).*

Blocked exhaust/venting system.

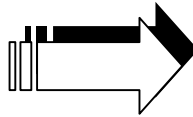

Have stove and venting cleaned and inspected.

Severe negative pressure in area where unit is installed.

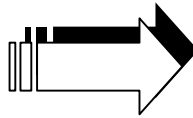

Check the operation by opening a window.

Does this solve the problem?

If it does, install fresh air intake to unit or room. Venting system may require vertical section to move termination into a low-pressure zone.

CONTINUED ON NEXT PAGE

LIGHT #2 ON HEAT OUTPUT BAR FLASHING CONTINUED

Vacuum switch failure.

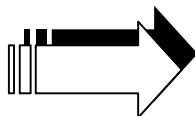

Bypass the vacuum switch, if this corrects the problem check for above problems before replacing the vacuum switch.

Damage to gray wires between circuit board and vacuum switch.

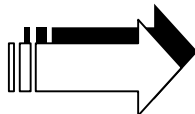

Inspect wires and connectors.

Combustion blower failure.

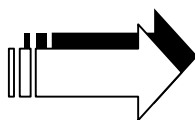

The combustion blower is not turning fast enough to generate the proper vacuum in the exhaust channel.

Visual check – is the blower motor turning?

Check the exhaust blower voltage across the blower wires ($\geq 114V$ on #5 setting and $\geq 82V$ on #1 setting).

Replace the circuit board if the voltage reading is less than 82V with a line voltage $>115vac$.

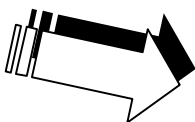

Check vacuum levels in the exhaust channel by bypassing the vacuum switch, and then remove the vacuum hose from vacuum switch. Check exhaust vacuum readings by placing the open end of the vacuum hose on a Magnahelic gauge (readings must be above .10" W.C. on low fire).

If the motor fails to reach a 0.10" w.c. reading, then *replace the combustion blower (part# 50-473).*

**2) LIGHT #3 ON HEAT
OUTPUT BAR FLASHING**

If light #3 on the heat output bar is flashing, the exhaust temperature sensor contacts have opened.

Possible causes:

Fire has gone out.

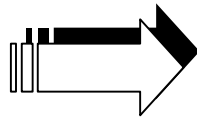

Check the hopper for fuel level.

Fill if required.

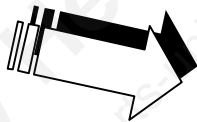

The air damper setting is incorrect.

Excessive air may consume the fire to quickly before the next drop of fuel. Leaving completely unburned fuel in the burn pot liner.

Insufficient air will cause build up, further restricting the airflow through the burn pot liner. This in turn will cause the fuel to burn cold and very slowly. Fuel may build up and smother the fire.

(NOTE: unit may require a change to the vent system or installation of fresh air to correct Air to Fuel ratio problems).

CONTINUED ON NEXT PAGE

LIGHT #3 ON HEAT OUTPUT BAR FLASHING CONTINUED

Fire has gone out continued.

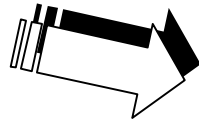

The combustion blower is not turning fast enough to generate the proper vacuum in the exhaust channel.

Visual check – is the blower motor turning?

Check the exhaust blower voltage across the blower wires ($\geq 114V$ on #5 setting and $\geq 82V$ on #1 setting).

Replace the circuit board if the voltage reading is less than 82V with a line voltage $>115vac$.

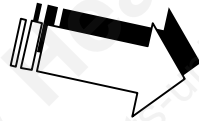

Check vacuum levels in the exhaust channel by bypassing the vacuum switch, and then remove the vacuum hose from vacuum switch. Check exhaust vacuum readings by placing the open end of the Vacuum Hose on a Magnahelic gauge (readings must be above .10" W.C. on low fire).

If the motor fails to reach a 0.10" w.c. reading, then *replace the Combustion Blower (part# 50-473)*.

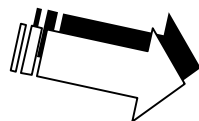

Poor quality fuel. Insufficient energy in the fuel to produce enough heat to keep the stove burning or operational.

CONTINUED ON NEXT PAGE

LIGHT #3 ON HEAT OUTPUT BAR FLASHING CONTINUED

Exhaust temperature sensor failure.

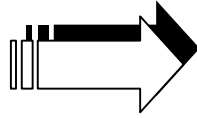

Replace sensor.

To reset the circuit board after a trouble code – push the ON/Off button.

**3) AUGER LIGHT FLASHES
BUT AUGER MOTOR DOES
NOT TURN AT ALL**

Possible causes:

The 200°F (93°C) high limit temperature sensor has tripped.

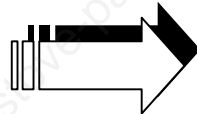

Reset sensor and determine cause – was it Convection Blower failure or 160°F (71°C) temperature sensor failure if unit is equipped.

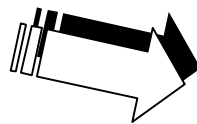

If the auger gearbox does not turn but the motors armature does try to spin then the auger is jammed. Try to break apart jam by poking at the jam through the drop tube. If this fails then empty the hopper and remove the auger cover

****Remember to re-seal the cover after installation****

GENERAL
1) THE IGNITOR DOES NOT WORK

THE UNIT WILL NOT LIGHT

Make sure the burn pot liner is pushed tight against the ignitor tube.

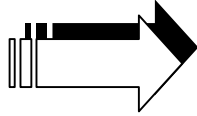

Correct if necessary.

EF-2, 3, 4, 5

Place a jumper wire across the two leads at the 120° F (49°C) ignitor sensor.

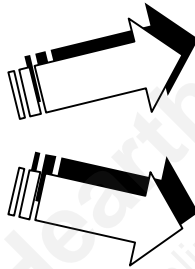

If the ignitor works replace the sensor.

If the ignitor does not work, replace the ignitor.

CHECK THE COLOR OF THE IGNITOR

CHECK THE FUSES ON THE CIRCUIT

Remove the burn pot and the burn pot liner and look into the ignitor tube.

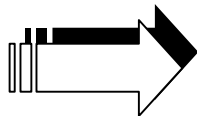

If it does not come to the right color, replace the ignitor.

THE COLOR OF THE IGNITOR SHOULD BE BRIGHT ORANGE.

2) THE STOVE KEEPS GOING OUT

If the stove goes out and leaves fresh unburned pellets or cigarette like ashes, the fire has gone out before the 140° F (60°C) temperature sensor shuts the stove off.

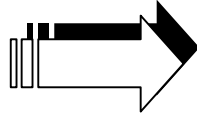

Check the position of the slider damper to make sure it is the correct position.

Turn the dial-a-fire up slightly (poor quality pellets).

If the stove goes out and there are partially unburned pellets left in the burn pot liner, and the unit shuts off due to the exhaust sensor opening before the fire went out. Too much/little air, power failure or poor quality fuel.

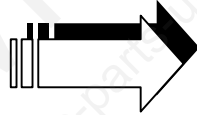

Adjust the air at the slider damper.

Check to see if the stove needs a more complete cleaning.

If the stove goes out and there are no pellets in the burn pot liner and the auger is stopping. (REFER TO #3 and #5 in the dial-a-fire section of this manual).

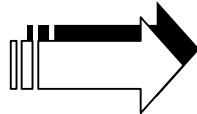

Turn the Dial A Fire up slightly (poor Quality pellets require a little higher setting).

Did the power go out?

If the auger is stopping (refer sections #5 in the dial-a-fire section of this manual).

COMPONENTS OF A PELLET STOVE

AUGER AND AUGER MOTOR

This 1 RPM motor is responsible for turning the auger shaft, which in turn transports pellets to be dropped into the burn pot. The Timing Control Module and the Dial-A-Fire control the auger motor.

GREEN LIGHT

(EF 3, 4) This light will flash in conjunction with the pulses of the Auger.

(EF 2) Signals you to put the stove into the auto position

CONVECTION BLOWER

This blower mounted on the right hand side of the stove draws room air from the back of the stove and passes the air through the heat exchanger tubes and back into the room. The sealed system keeps the room air separate from the combustion air. The fan controller controls this fan.

CONVECTION FAN CONTROLLER

This controller is responsible for varying the speed of the convection blower. The stove does have a fan control override. Should the convection blower be set on low and the Dial A Fire set on high, the convection blower will by-pass the fan controller and go to high speed. This will cool the stove until control is given back to the fan controller. To eliminate the possibility of the fan cycling the fan controller and the Dial A Fire should be set proportionately to one and other.

DIAL A FIRE (HEAT OUTPUT CONTROL)

This unit is responsible for controlling the timing of the auger motor. When turned clockwise it will cause the OFF time between auger pulses to shorten, resulting in more heat output and pellet consumption. Turn the counter clockwise and the reverse will happen. When it is turned fully counter clockwise until it clicks the auger will stop.

COMBUSTION/ EXHAUST BLOWER

This fan mounted on the left hand side of the stove is responsible for drawing outside fresh air into the combustion chamber for burning. The hot air then continues to be drawn over the heat exchanger tubes and then into the exhaust channel. It is then pushed out through the exhaust system.

START UP SWITCH (EF 3, 4)

When this switch is pressed it will initiate a start up timer including the igniter if installed in the unit.

AUTO/MANUAL SWITCH

This starts the stove in the manual position, when the green light comes on push the switch to the auto position.

120°F(49°C) N/C IGNITER TEMPERATURE SENSOR

this sensor (mounted on the exhaust channel) will turn the igniter OFF when the exhaust temperature reaches 120°F(49°C)

START UP TIMER(EF 3, 4)

This start up timer bypasses the exhaust temperature sensor allowing the stove to operate when the unit is cold. The timing cycle is initiated by pressing the start up switch. The start up timer is located right under the timing control module on the right hand side rear pillar. This is also responsible for turning the igniter ON

TIMING CONTROL MODULE

The timing control module is mounted above the start up timer located on the right rear support pillar. This module controls the switching of power to the auger. The timing control modules switching duty is controlled by the Dial A Fire.

VACUUM SWITCH

This safety device (located on the left rear support pillar) detects vacuum in the exhaust system. If the blower fails or the vent pipe becomes plugged, this switch will sense that there is no air flow through the exhaust vent and will stop the auger from feeding pellets and then finally shutting the stove OFF.

CONTROL BOARD

This device controls the operation of the unit. This device has been designed to fully operate the unit; the control board can change the amount of fuel that delivered to the burn pot as well as room air blower (convection blower) functions. This device is also responsible for turning the unit ON and OFF. This control board can be operated manually or a wall thermostat can be installed on this unit as well

EXHAUST TEMPERATURE SENSOR

This sensor mounted on the exhaust blower housing has two functions:

- Should the fire go out, this sensor will shut the stove off when the exhaust temperature drops below its set point.
- When the auger is turned OFF via the Dial A Fire, the exhaust temperature will drop, when the exhaust temperature drops below set point the sensor will shut the stove OFF.

160°F(71°C) CONVECTION FAN SENSOR

When this sensor mounted on the left side firewall reaches 160°F(71°C) the convection blower will go to high cooling the unit before it overheats.

200°F(93°C) MANUAL RESET HIGH LIMIT TEMPERATURE SENSOR

This sensor (located on the right hand side of the firewall) has a red push button in the center of the sensor. This is a safety device. In the event that the convection blower fails, this sensor will detect the stove might overheat and will shut the power OFF to the auger motor.

IGNITOR

A heating element used to ignite the pelletized fuel when the start up switch is activated; the ignitor is activated by the start up timer. Air passes through the igniter tube, which the air becomes super heated drying the fuel and then igniting the fuel through convection

PHASE CONTROLLER (EF-4)

The EF 4 has a phase controller which is responsible for reducing the speed of the Combustion/Exhaust blower as the Dial-A-Fire is turn down to a lower flame setting, this will decrease the air flow through the appliance helping the stove run more efficiently.

FLAME CHARACTERISTICS

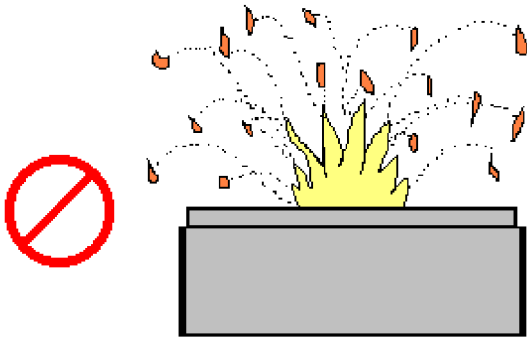

A SMALL BLOW TORCH LIKE FLAME IS A RESULT OF TOO MUCH AIR BEING SUPPLIED TO THE FIRE CAUSING THE FLAME TO BECOME VERY SHORT AND BRISK WITH A BRIGHT YELLOW ALMOST WHITE FLAME APPEARANCE THERE WILL ALSO BE A LOT OF EMBERS OR SPARKS EXITING THE FLAME AND BURN POT LINER
TO FIX THIS CONDITION OPEN THE SLIDER DAMPER UNTIL AN EFFICIENT FLAME IS ACHIEVED

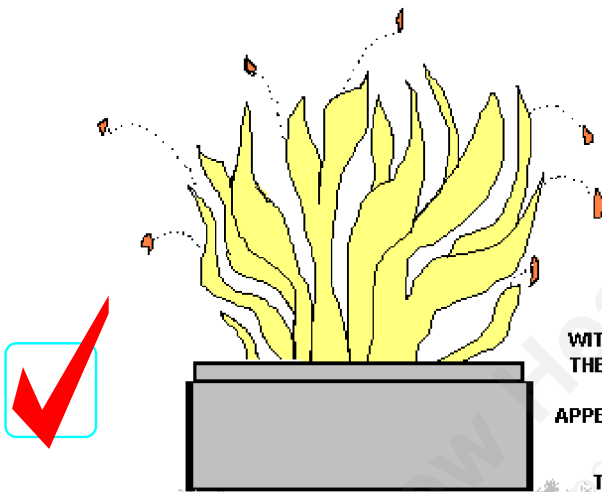

WITH THE SLIDER DAMPER SET IN THE CORRECT LOCATION THE FLAME WILL BE BRISK, BUT NOT BLOWING. THE FLAME WILL ALSO HAVE A YELLOW TO BRIGHT ORANGE APPEARANCE. THERE SHOULD ALSO BE SOME SMALL EMBERS OR SPARKS EXITING THE FLAME AND BURNPOT LINER.
THIS IS AN EFFICIENT FLAME AND IS THE BEST FOR PROPER OPERATION.

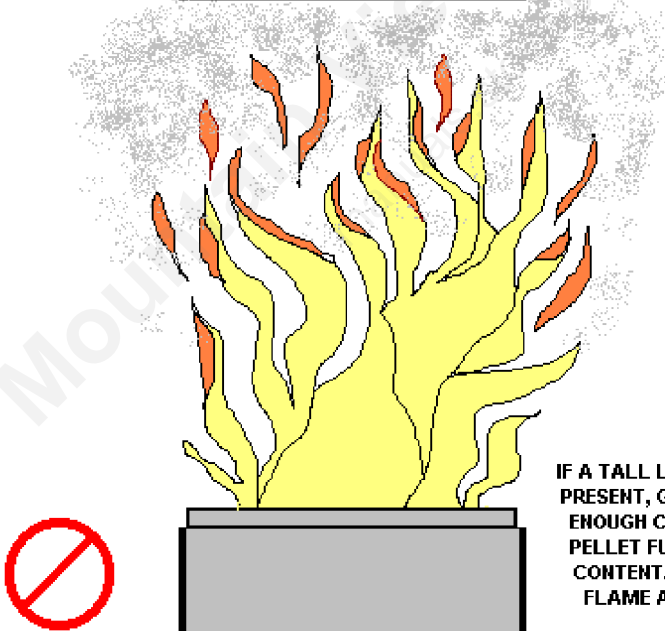

IF A TALL LAZY ORANGE WITH BLACK TIPPED FLAME IS PRESENT, GENERALLY THIS COULD BE A RESULT OF NOT ENOUGH COMBUSTION AIR TO THE FIREPLACE, OR THE PELLET FUEL BEING USED HAS A VERY HIGH MOISTURE CONTENT. ALSO A TRAIL OF SMOKE WILL LEAVE THE FLAME AND WILL END UP SOOTING THE APPLIANCE.

TO FIX THIS CONDITION OPEN THE SLIDER DAMPER TO LET MORE AIR TO THE FIRE, ALSO MAKE SURE THE PELLET FUEL BEING USED IS DRY.

EF 2 WIRING DIAGRAM

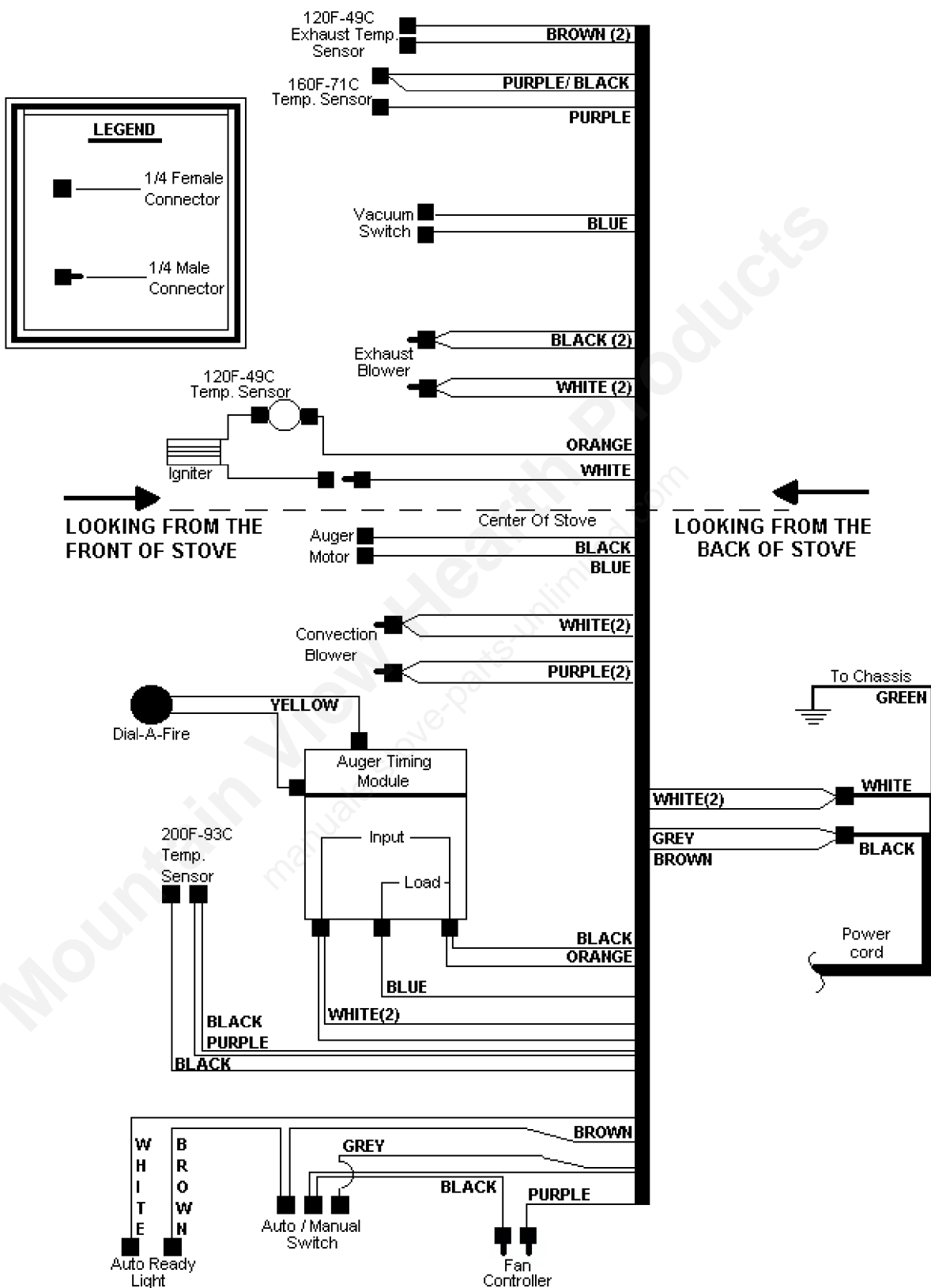

EF 3 Bay i WIRING DIAGRAM

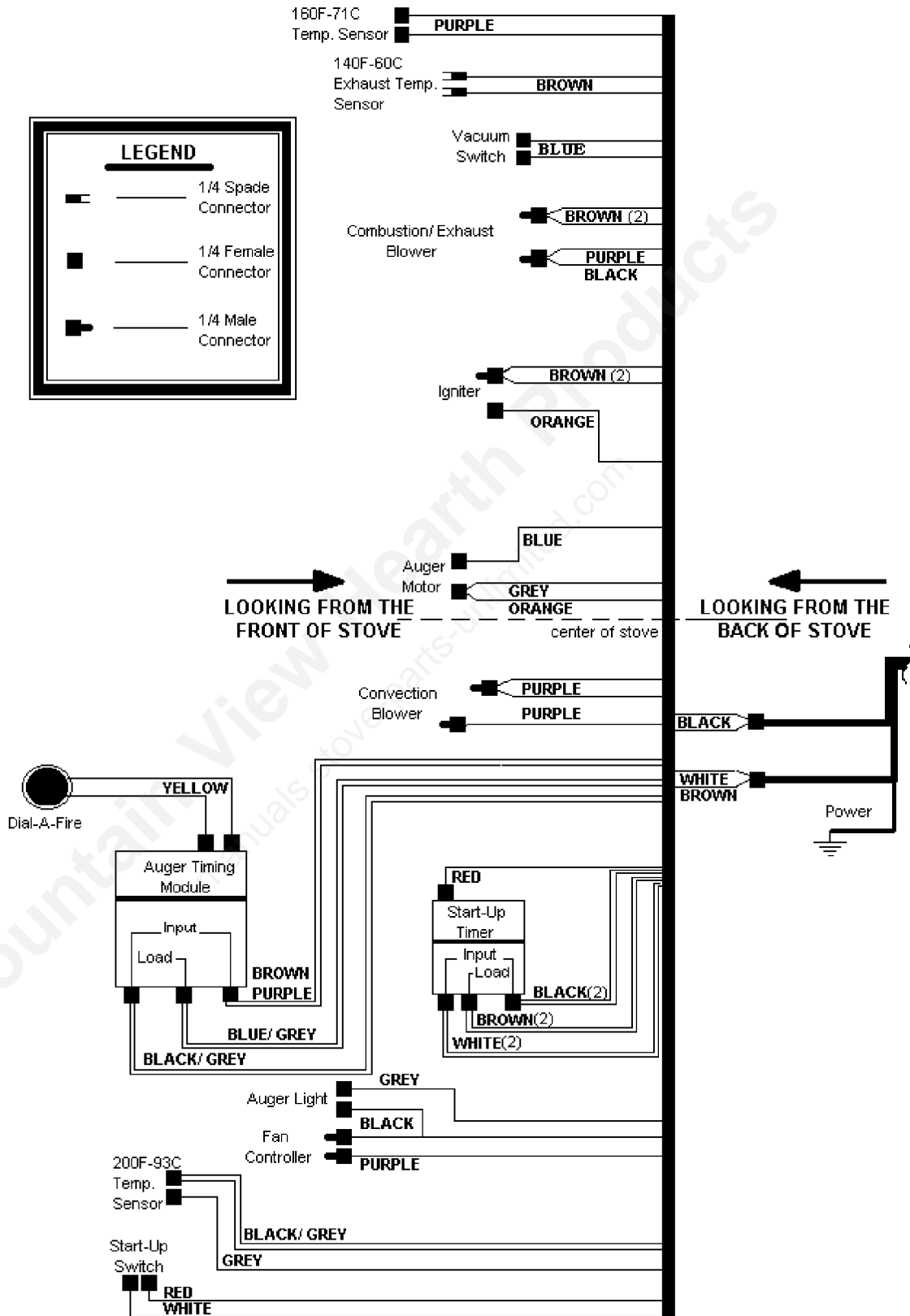
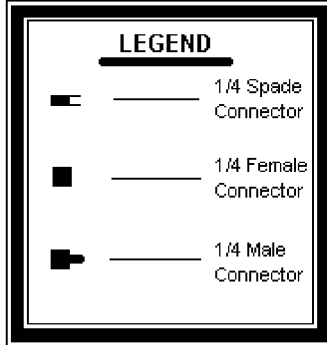

EF 2-3 WIRING DIAGRAM (THERMOSTAT INTERFACE)

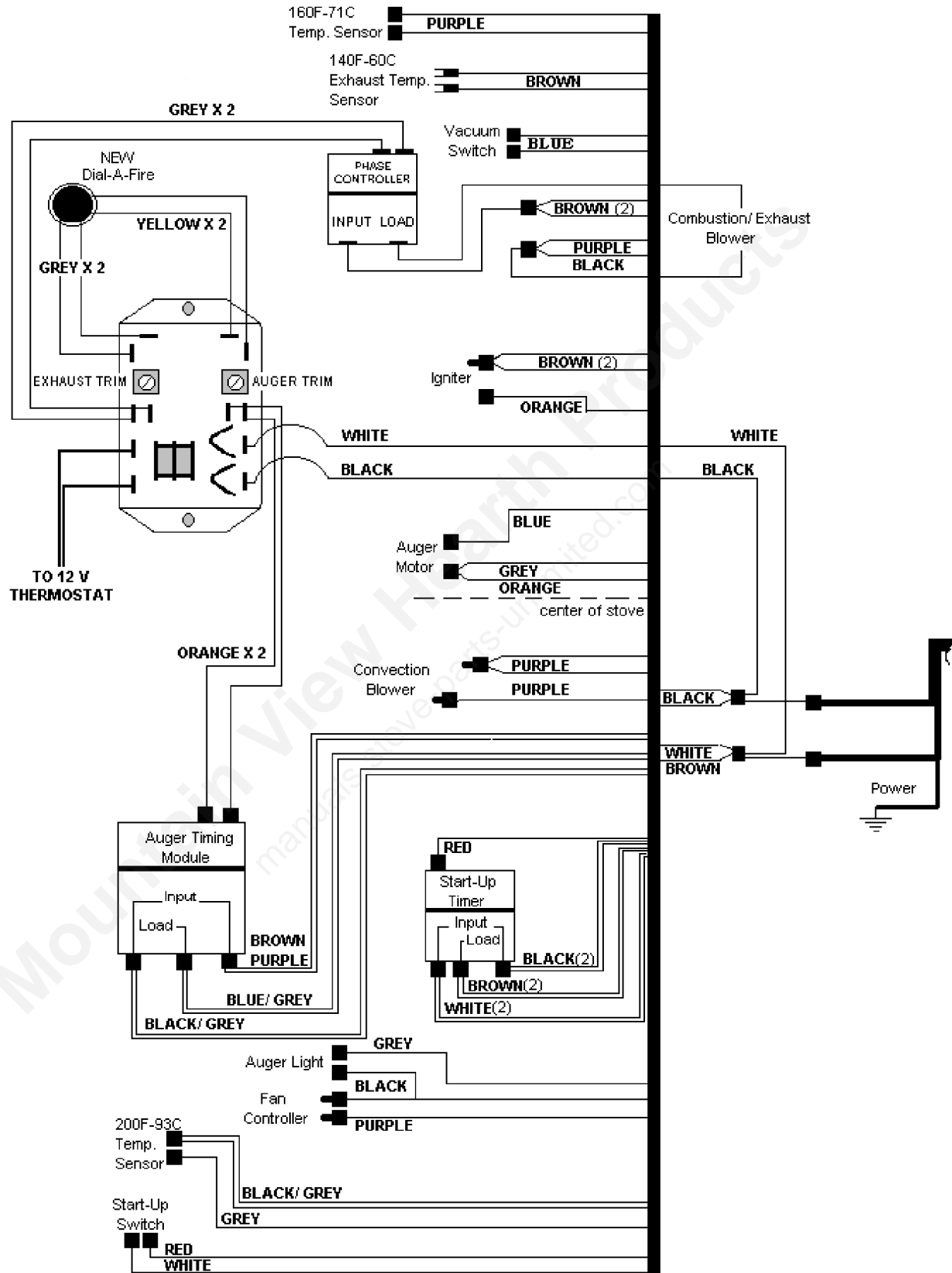

EF 4 WIRING DIAGRAM (THERMOSTAT INTERFACE)

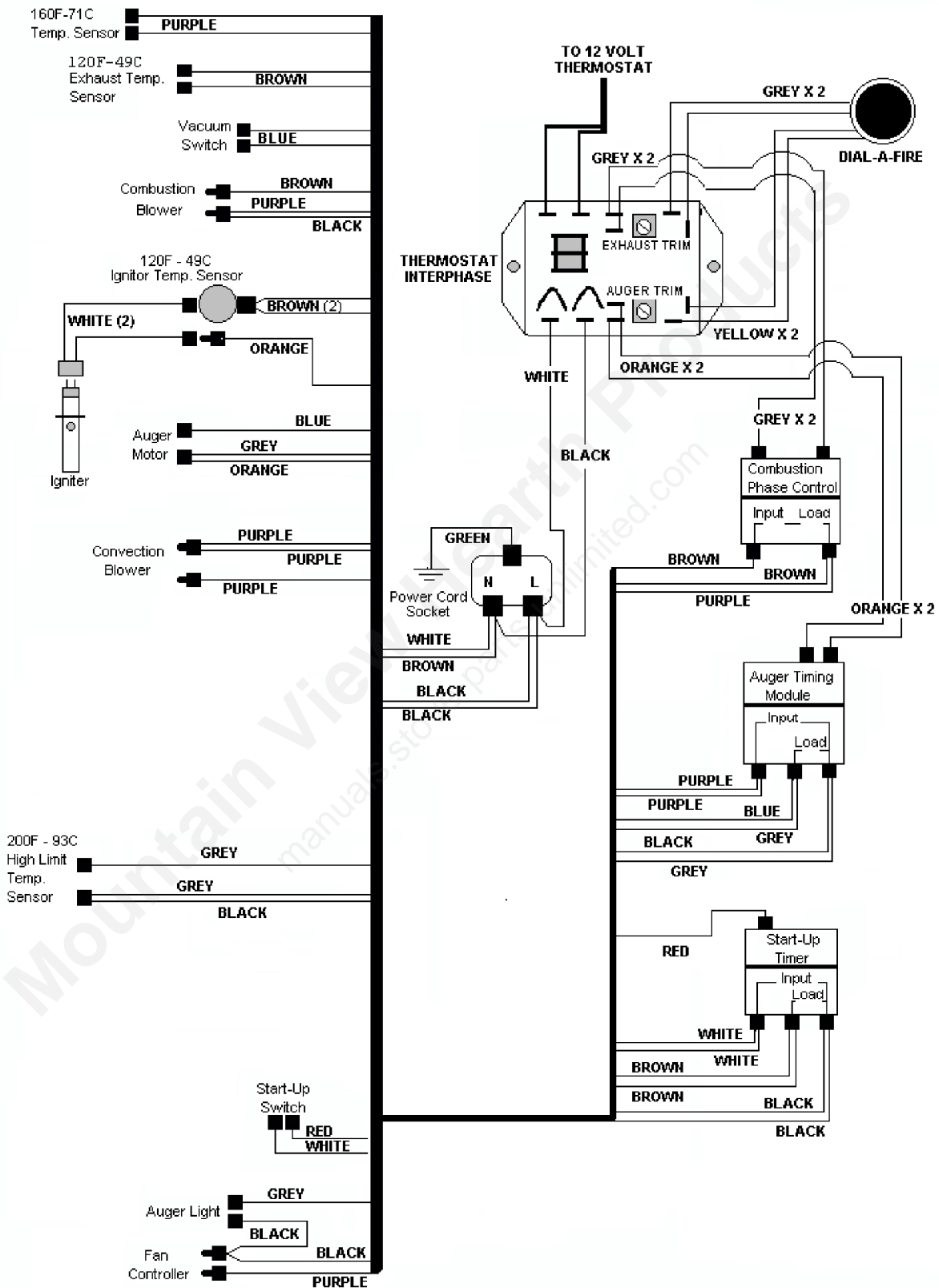

EF 4 WIRING DIAGRAM

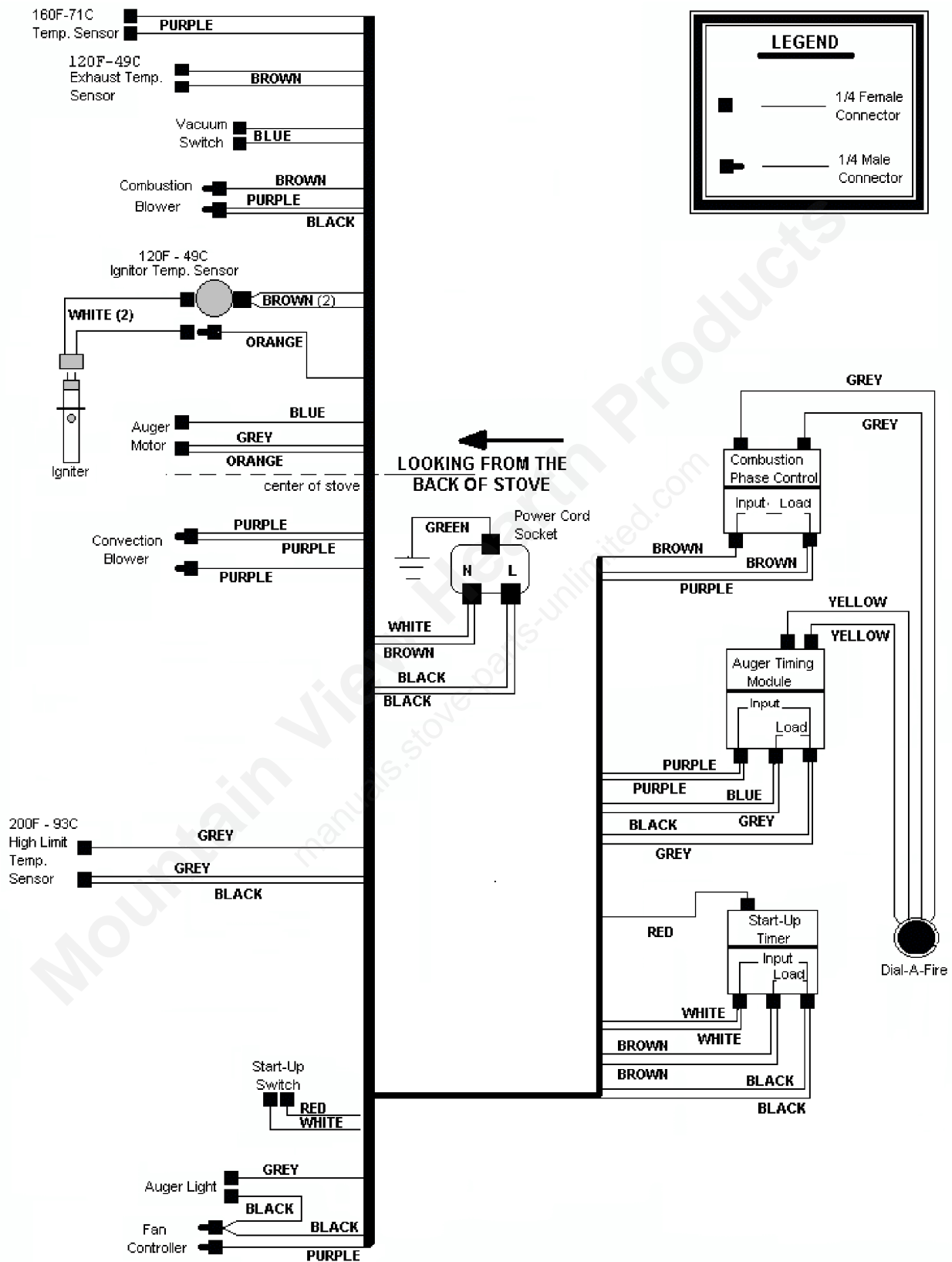

EF 5 WIRING DIAGRAM – Dial-a-Fire

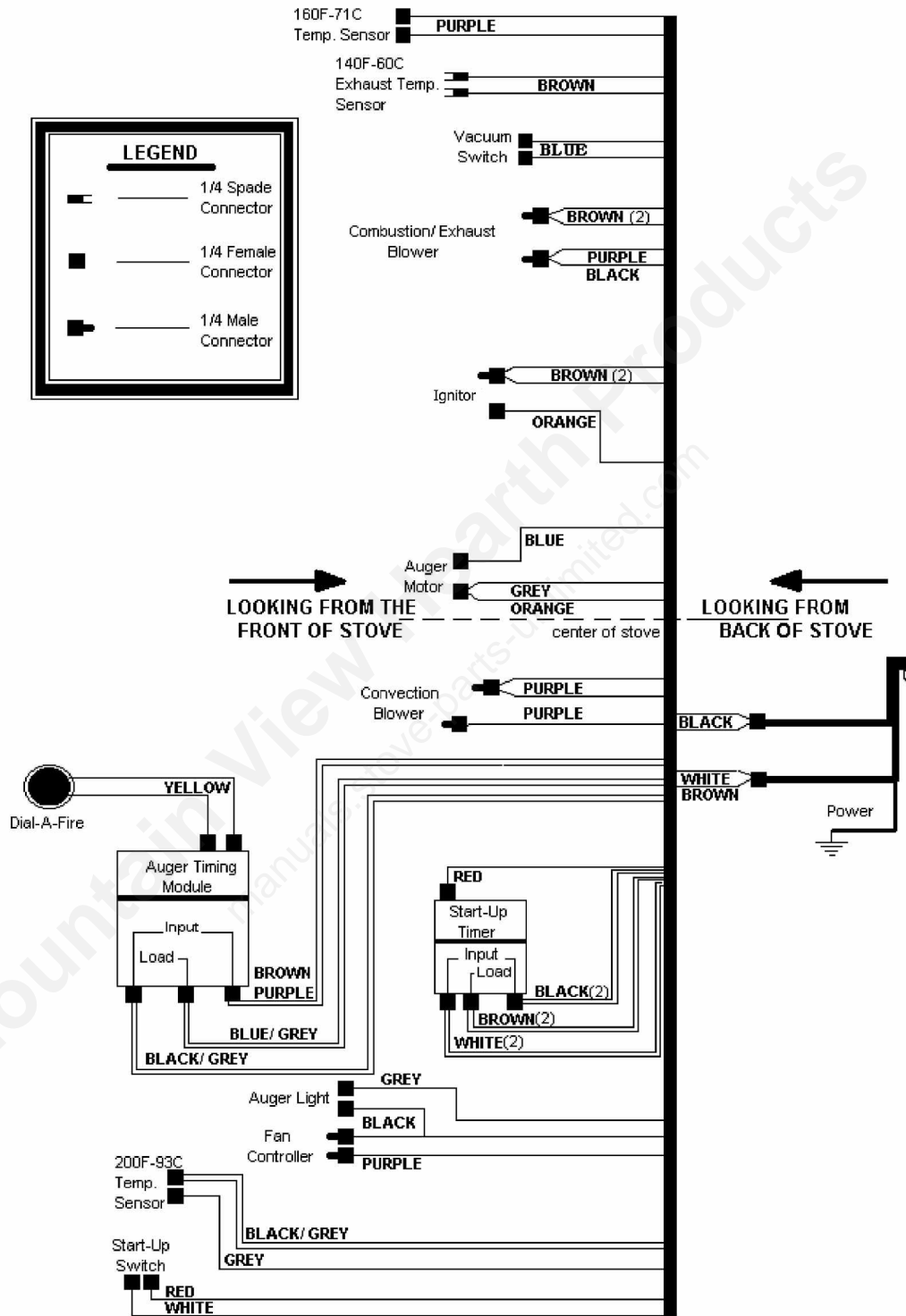

EF 5 WIRING DIAGRAM – Circuit Board

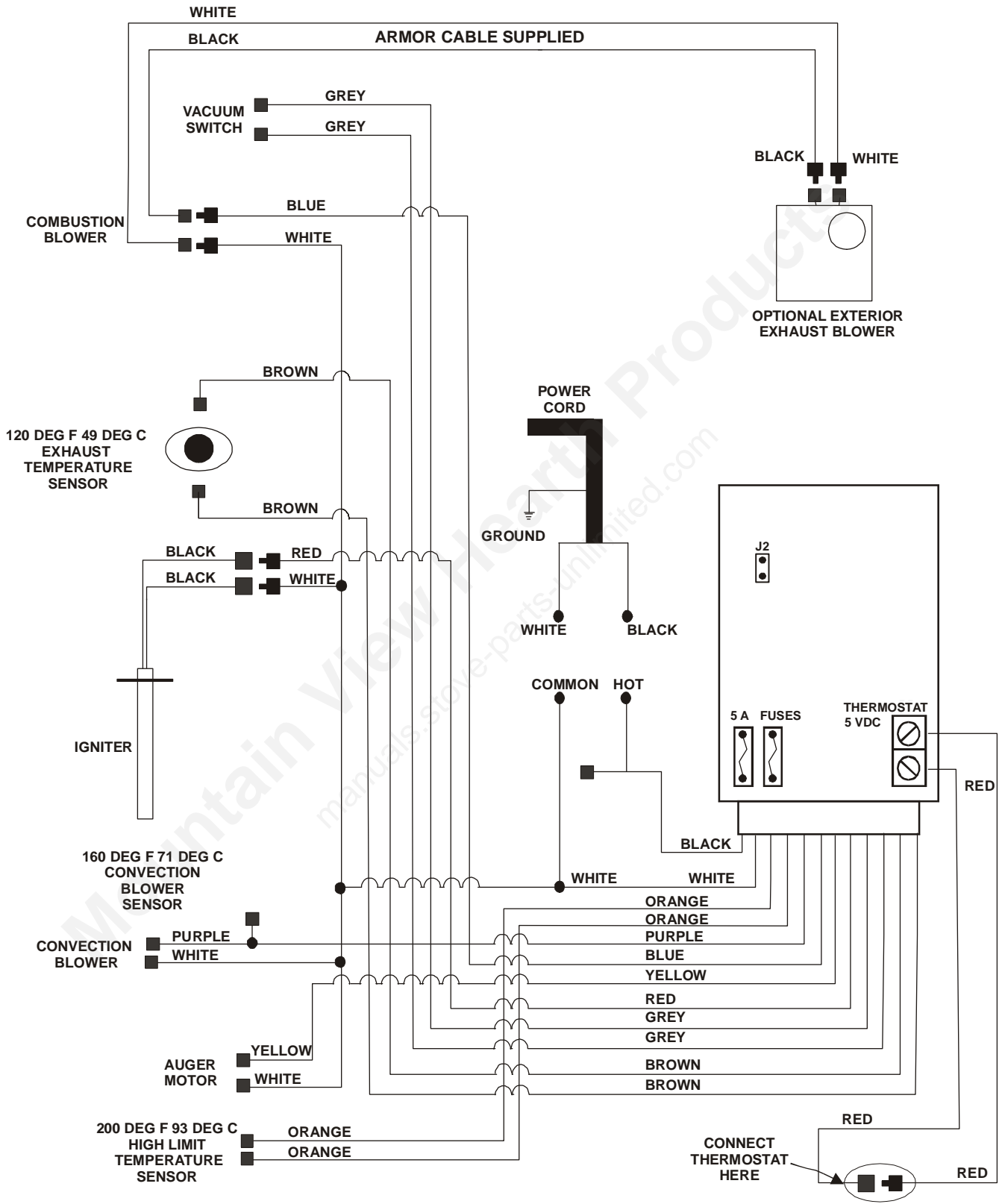

WINDSOR WIRING DIAGRAM

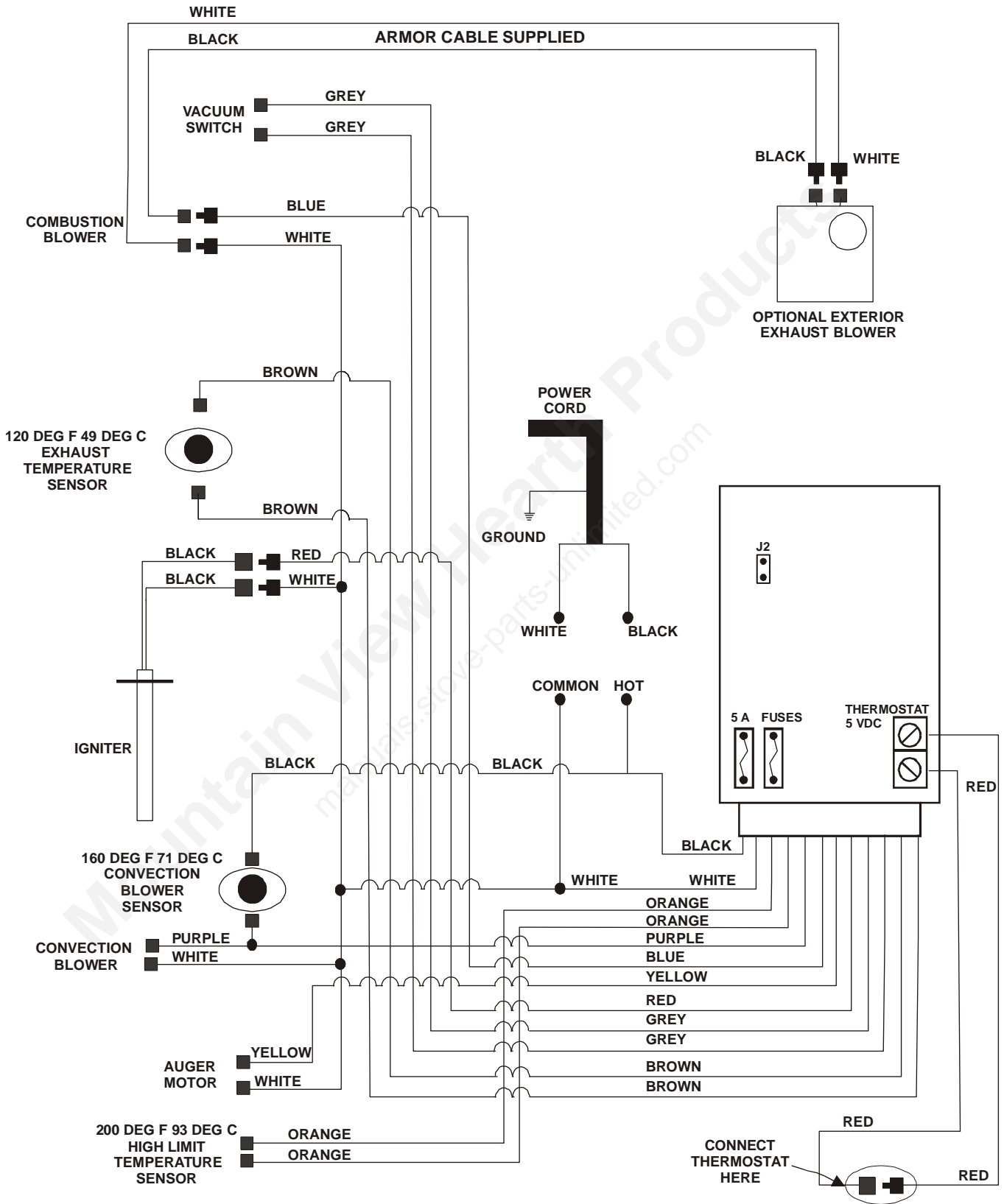

MERIDIAN WIRING DIAGRAM

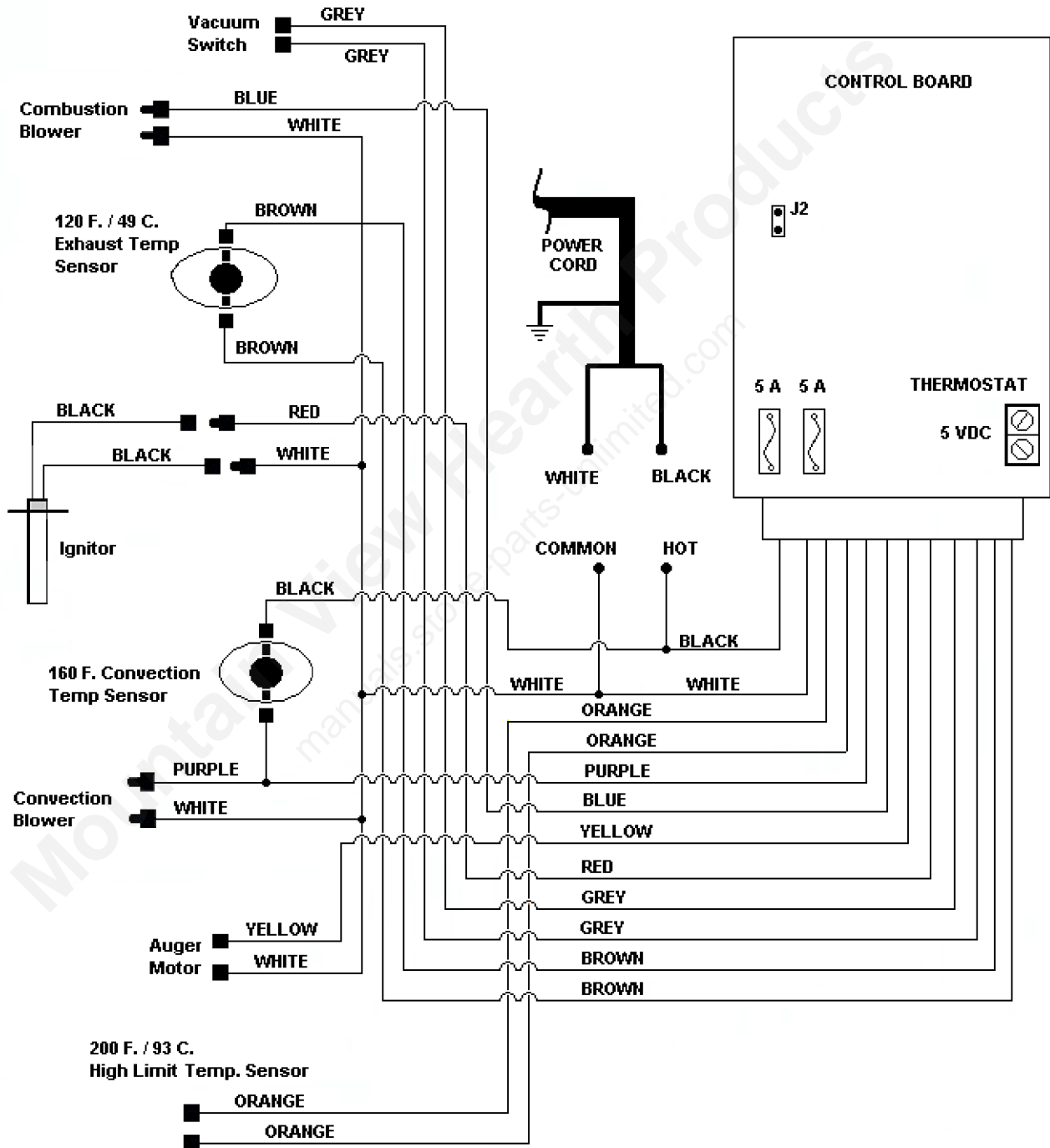

04/22/02

11) GLOSSARY

BURN POT AND BURN POT LINER

This is where the pellets are dropped from the hopper and then burned.

BLOWER MECHANISM

Device used either to remove exhaust gases from the stove or move air over the heat exchanger and into the room

CLEARANCE TO COMBUSTIBLES

The distance required to maintain a safe operating distance to a combustible material.

CLINKERS

Creosote builds up from a higher water content pellet or insufficient fresh air supply.

COMBUSTION CHAMBER

An area in the stove where the fire is or where combustion of the fuel takes place.

CONTINUITY TEST

By using a multimeter set the instrument on OHMS, this is determine if the circuit is complete, or continuous.

CREOSOTE

Black tar like build up produced by high water content pellets or incomplete combustion.

EFFICIENT FLAME

Is it a short or brisk forced flame with no black tips or lazy appearance.

EXHAUST SYSTEM

Designed to remove products of combustion from the house in a safe and proper fashion.

FRESH AIR INTAKE

This is a supply of fresh air pulled into the appliance to help combustion of the fire.
(Fresh air can also be pulled in from a vented crawl space)

MAGNETIC PRESSURE GAUGE

This is an extremely sensitive measuring device that measures vacuum in the stove.
(this measurement is in inches of water column. (Example: .01"wc)

MULTIMETER

An instrument used to measure Voltage (VAC VDC), Resistance (OHMS)

PELLET VENT

Is a listed component vent made of stainless steel inside and either a stainless steel or galvanized outer pipe. Can also be a stainless flexible vent for fireplace insert applications.

PELLETIZED WOOD FUEL

Recycled sawdust from sawmills or furniture manufactures. The fuel is compressed and squeezed through an extrusion, all aspects of the fuel are considered.
(Example ash content, water content, fines etc.)

PYROCERAMIC

Is a type of glass used on the stove, this glass is rated for a very high temperature.
Temperature rating on this glass is 1400°F.

RATING PLATE

A plate in or on the appliance, which shows all certifications as well as the Serial number and Model number of the stove.

RICH BURN

Lazy orange black tipping flames resulting in soot build up as well as the production of carbon monoxide.

SLIDER DAMPER

Is a device used to adjust the amount of air to the fire to achieve an efficient flame in the stove.