

PLEASE SAVE THESE INSTRUCTIONS FOR FUTURE REFERENCE.

Enviro Maxx-1 Heat Distribution Kit MANUAL

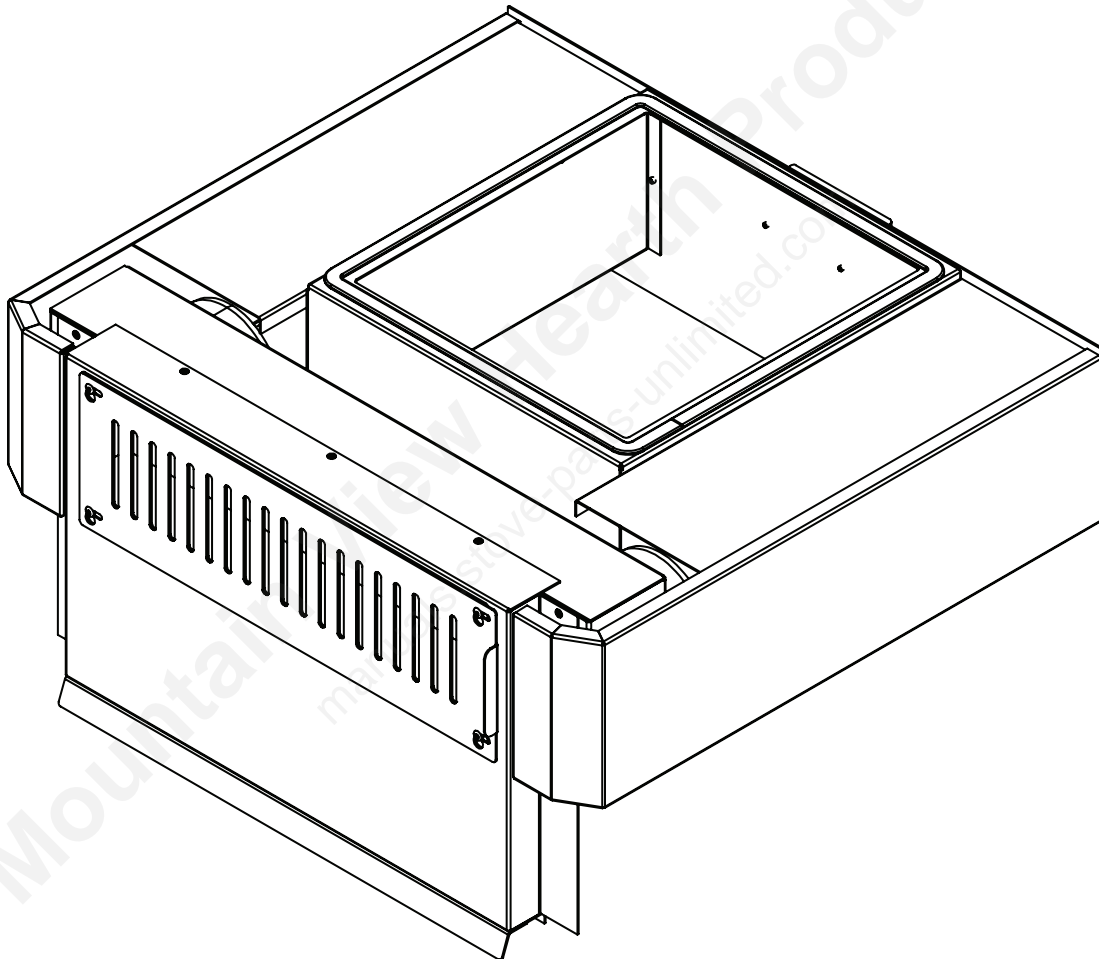

50-3067



PLEASE READ THIS ENTIRE MANUAL BEFORE INSTALLATION AND USE OF THIS PELLET-BURNING ROOM HEATER. FAILURE TO FOLLOW THESE INSTRUCTIONS COULD RESULT IN PROPERTY DAMAGE, BODILY INJURY OR EVEN DEATH.

CONTACT YOUR LOCAL BUILDING OR FIRE OFFICIALS ABOUT RESTRICTIONS AND INSTALLATION INSPECTION REQUIREMENTS IN YOUR AREA.

Intertek

TABLE OF CONTENTS

Safety Warnings & Recommendations.....	2
Installation.....	3
Heat Distribution Kit.....	3
Ducting Specifications.....	8
Wiring.....	9
Wiring Diagram.....	10
Parts List.....	11

SAFETY WARNINGS & RECOMMENDATIONS

Please read this entire Manual before installing or operating your Enviro Pellet Stove with Heat Distribution Kit. Failure to follow these instructions may result in property damage, bodily injury or even death. Any unauthorized modification of the stove or Heat Distribution Kit is prohibited. All national and local regulations must be followed when operating this pellet stove with Heat Distribution Kit option.

WARNING: DO NOT INSTALL IN A SLEEPING ROOM.

CAUTION: THE STRUCTURAL INTEGRITY OF THE MANUFACTURED HOME FLOOR, WALL, AND CEILING/ ROOF MUST BE MAINTAINED.

Minimum ducting run must be atleast 36" vertical before going through a wall or the ceiling above. Maximum ducting runs should be 20ft or less, output will greatly decline after this length.

The wiring can not be modified in anyway, wire exactly as stated in this manual. Inproper wiring can lead to burns and property damage. Warranty is void if wired incorrectly or modified.

Unit **MUST** be set to Hi/Lo or Auto/Off mode for Heat Distribution Kit to function properly. The high limit switch will turn off unit in manual mode if wired correctly.

Installation: Ducting must have 1" clearance to any combustible material when going through a wall or floor, unless specifically stated in this manual.

Do not use plastic registers, metal registers must be used for Heat Distribution Kit installation. Do not cover or block outlet registers.

Do not have combustible materials touching or directly in front of outlet registers. Give wall registers at least 6 inches of clearance to any combustible materials, furniture, clothing ect.

Do not place anything directly above or in contact with floor registers. The installer must use supplied 1/4 inch insulation between register boot and combustible building materials. Ducting register boots/ adapter can not be installed with zero clearance.

Unit can not be ducted into previously existing heating appliance/ central heating ducts. Ducts for HDK must be installed as per manual.

Operation: Metal registers attached to Heat Distribution Kit ducting must be open during operation.

Do not touch any part of stove or Heat Distribution Kit while stove is running. **Unit is hot during operation. Keep children, clothing and furniture away. Contact may cause skin burns.** After unit is off give at least one hour before touching stove, registers, or refueling.

To access Heat Exchanger cleaning rods remove front grills. Wait until unit is cool to access.

Cycling down to a low mode regularly is normal, this keeps air discharge temperatures safe.

INSTALLATION INSTRUCTIONS

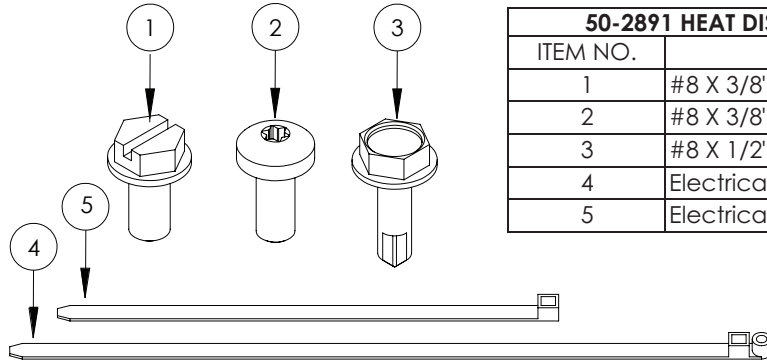

50-2891 HEAT DISTRIBUTION KIT HARDWARE		
ITEM NO.	DESCRIPTION	QTY.
1	#8 X 3/8" Sheet Metal Screw	12
2	#8 X 3/8" T-20 Screw	4
3	#8 X 1/2" Self Drilling Screw	5
4	Electrical Wire Tie 6in with Hole	4
5	Electrical Wire Tie 4in	2

1. Remove combustion adjustment slider knob as well as lock collar on left side of unit. Unscrew knob to remove. To remove the lock collar you will need a 3/32 Allen key.

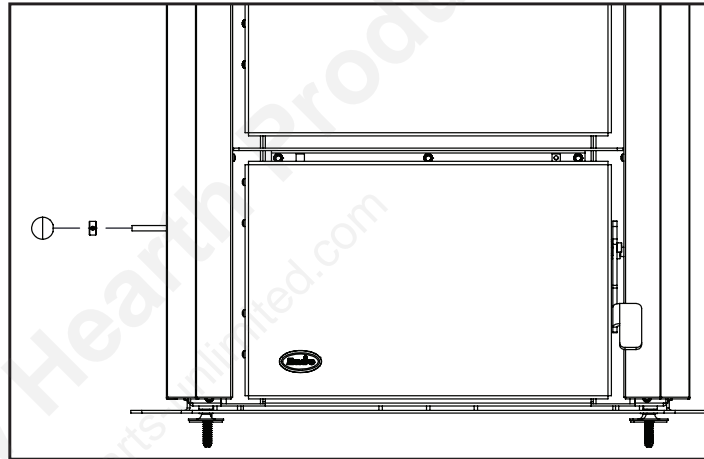

Figure 1: Adjustment knob and lock collar removal.

2. Remove cabinet sides by opening firebox and ash pan door handles, and loosen four #8 T-20 mounting screws on each side of stove.

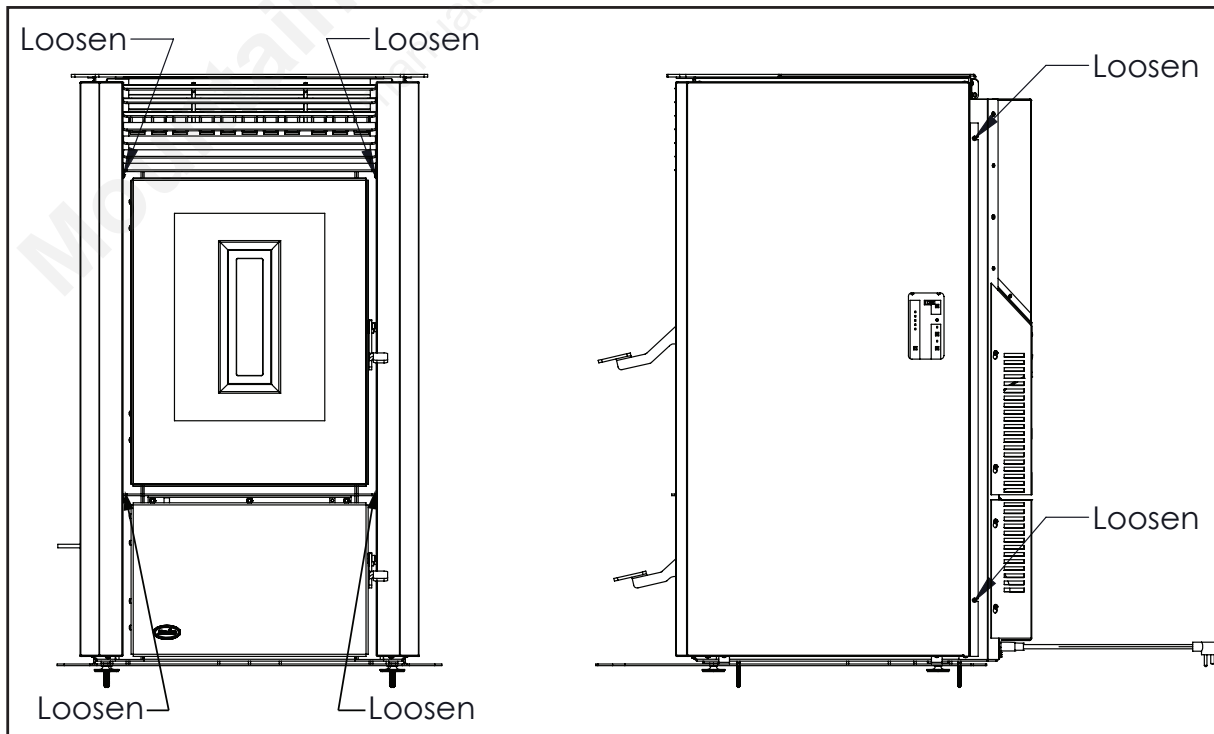

Figure 2: Cabinet side screws.

3. After loosening the screws holding on the cabinet sides, slide the sides toward front of stove to remove, figure 3.
4. Remove the four T-20 screws securing the Front Grill assembly, see figure 4.

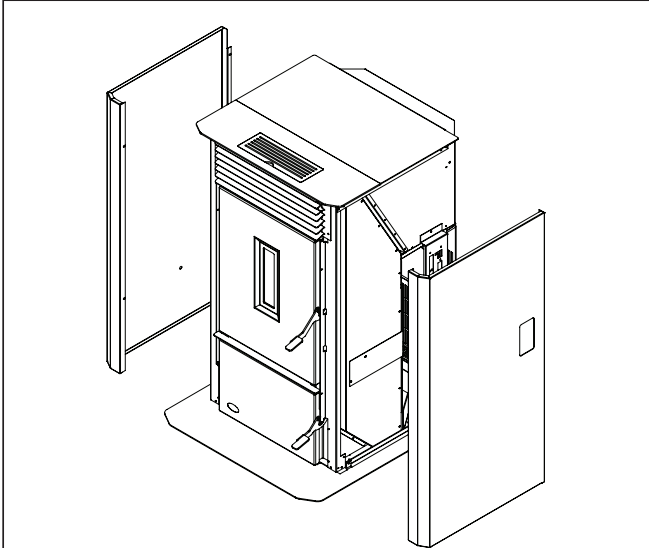

Figure 3: Cabinet sides removal.

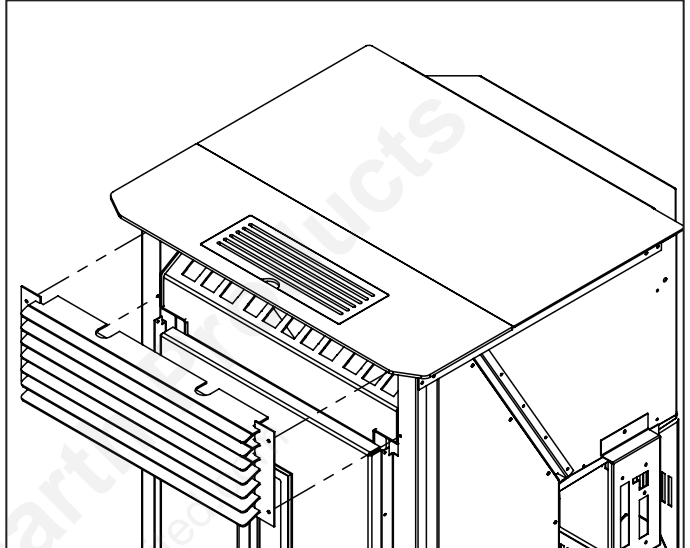

Figure 4: Original front grill removal.

5. Remove Front Top assembly, four screws, figure 5.
6. Remove four screws that are mounting the lid hinges. This will allow you to remove hinges and lid, see figure 6.

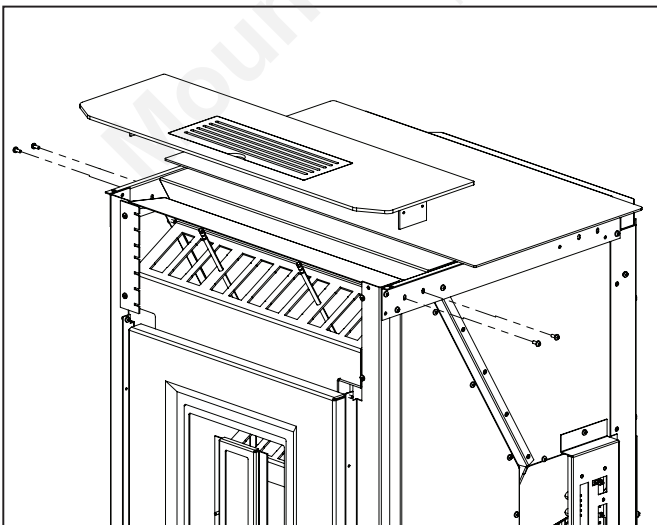

Figure 5: Front Top assembly removal.

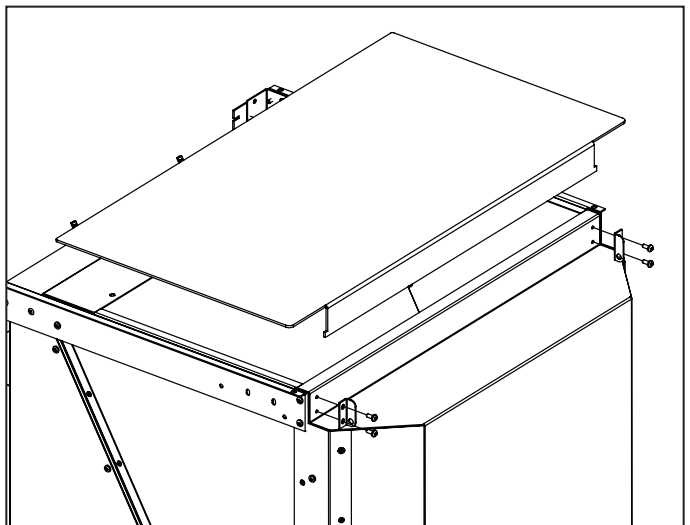

Figure 6: Lid and hinges removal.

7. Remove old lid gasket, a utility knife may be required, figure 7.

8. Install the Air deflectors, remove three screws from each side shown in figure 8, pull the vertical frame part forward slightly so the deflector can be fit behind. Re-install the screws two of them will secure the deflector.

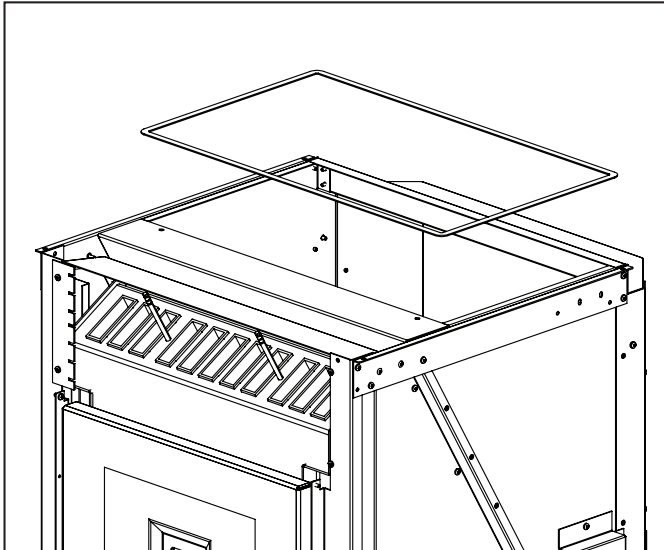

Figure 7: Original lid gasket removal.

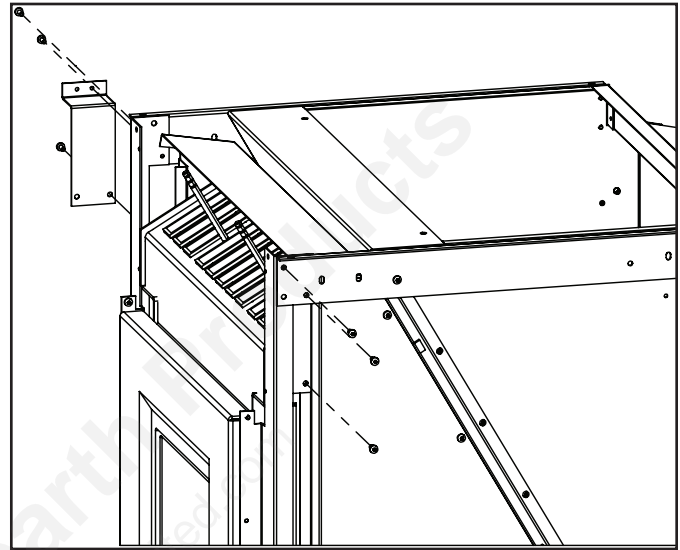

Figure 8: Front HDK assembly install.

9. Install Front HDK assembly. Assembly should slide downward into place and is secured using two #8 sheet metal screws. Screws thread into top holes where front original grill was mounted, figure 9

10. Install Back HDK assembly, first attach back plate using the original screws and existing hinge mount holes, figure 10.

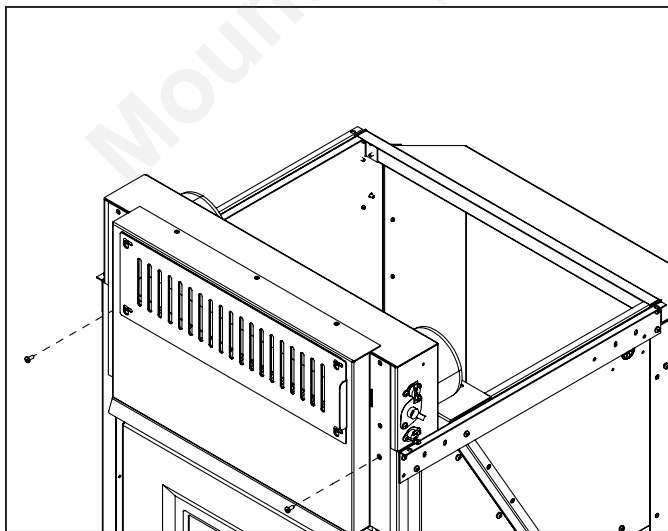

Figure 9: Front HDK assembly install.

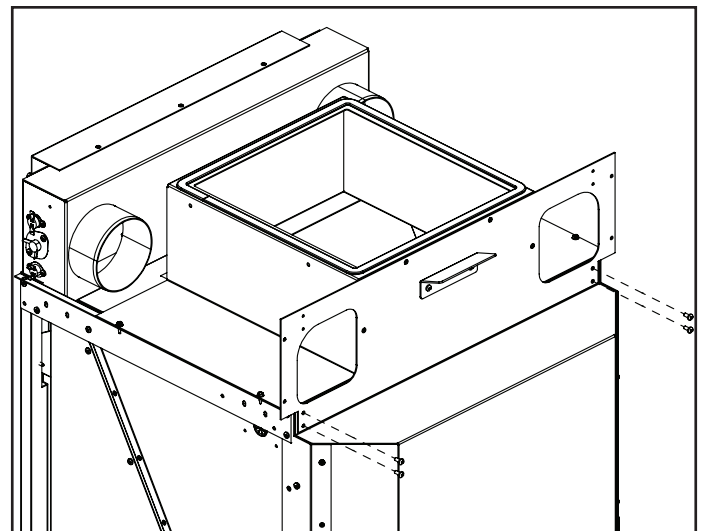

Figure 10: Back HDK assembly install.

11. Attach the hopper extension side flanges where the screw clearance holes are cut, line up edge of hopper extension with edge of support rail and use self drilling screws to secure. Attach the front flange on hopper extension using self drilling screw, figure 11.

12. Attach the Duct Shields using four provided #8 sheet metal screws, figure 12.

13. **You should now wire the kit.** Refer to page 10 for wiring instructions.

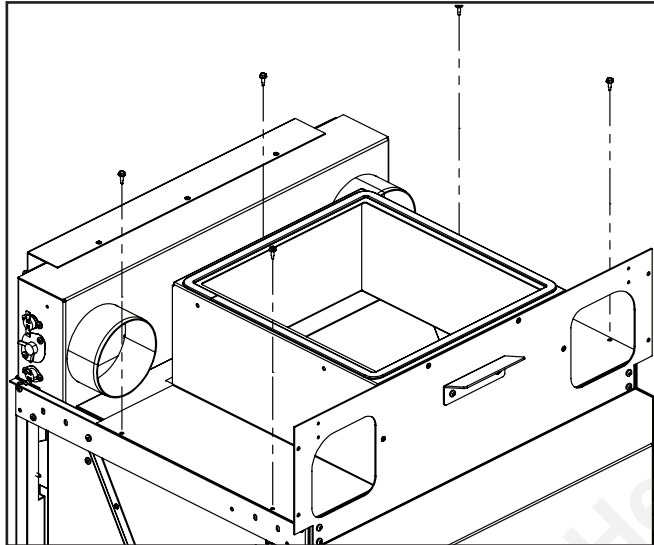

Figure 11: Back HDK assembly secure.

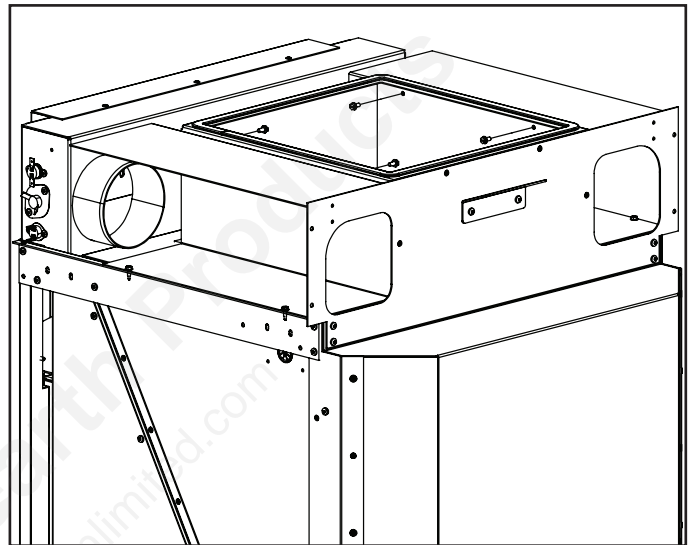

Figure 12: Install of duct shields.

14. Re-install original Front Top assembly with two #8 sheet metal screws. Use the front hole on the original Front top assembly side flanges. These will match up to holes on the sides of the Front HDK assembly.

15 Install Cab Side Extensions, flange on front will slide into slot on Front HDK assembly, figure 14

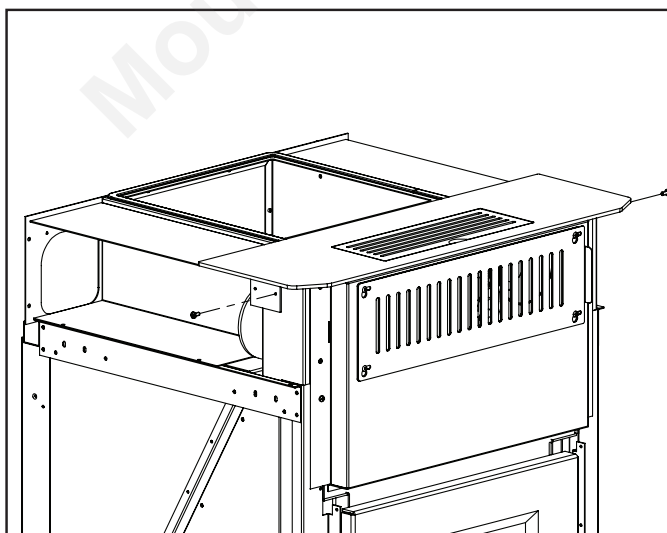

Figure 13: Re-install original front top assembly

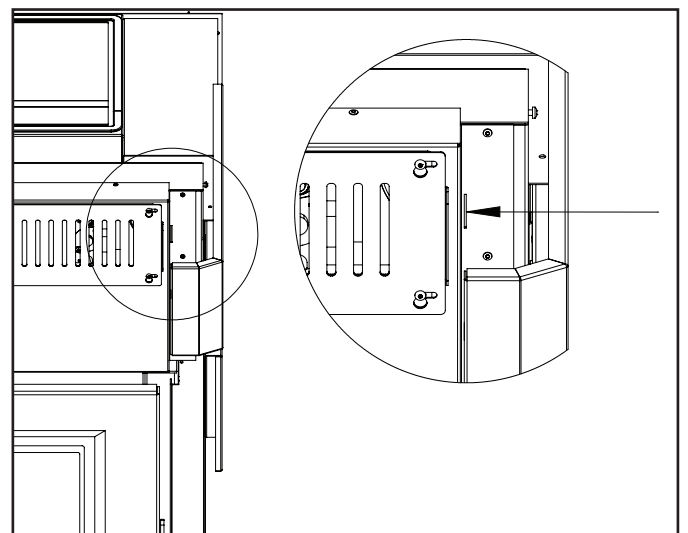

Figure 14: Cabinet side extension install slot.

14. Attach Cab Extensions to back plate using two #8 sheet metal screws on each side. Mount one hinge using #8 T-20 screws, see figure 15.

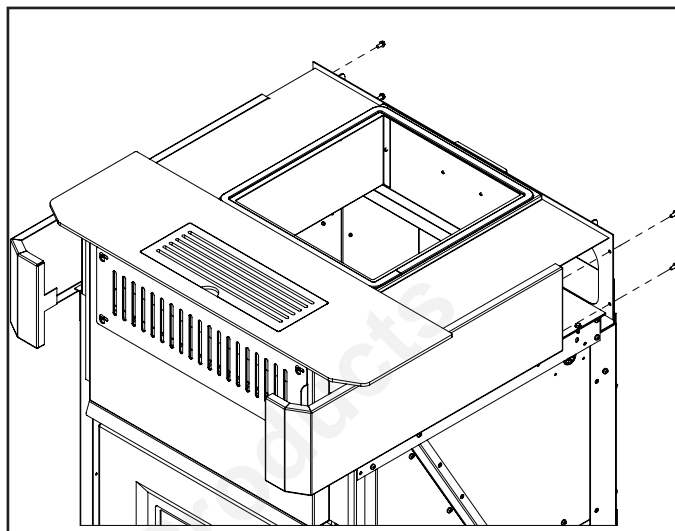

Figure 15: Cabinet side extension install.

15. Re-install hinges and lid. Hinge mounting holes have been shifted vertically up on the back plate. Mount one hinge then slide lid pivot in to hinge hole. Next slide other hinge on to opposite lid pivot and secure the hinge. Open and close lid a few times to check that lid is pivoting properly.

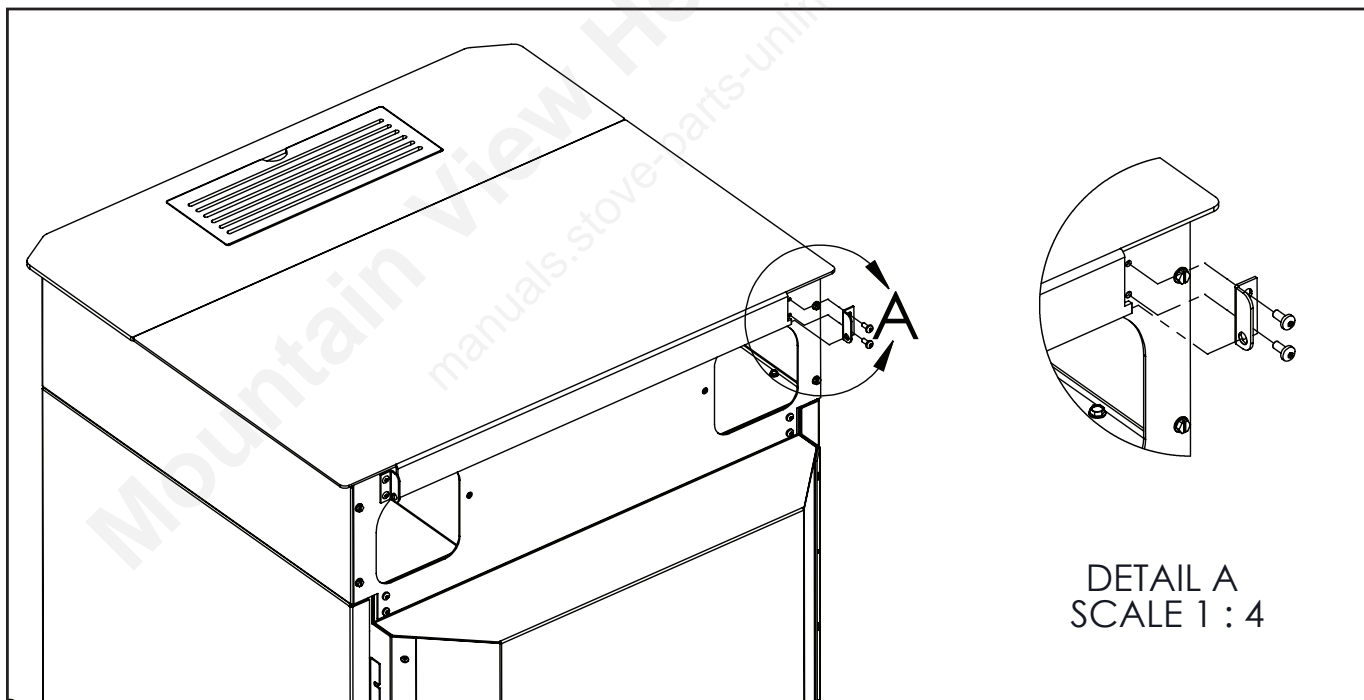

Figure 16: Lid and hinge install.

16. Re-attach the cabinet sides then the lock collar and adjustment knob. The opposite of steps 1 & 2.
17. Attach 4" diameter 20-30 gauge galvanized or aluminum ducting to outlets on HDK. Ducts should slide through holes in the back plate and on to outlet tubes.
18. Install ducting according to clearances stated in the warning section as well as the building and fire code in your local area.

DUCTING SPECIFICATIONS

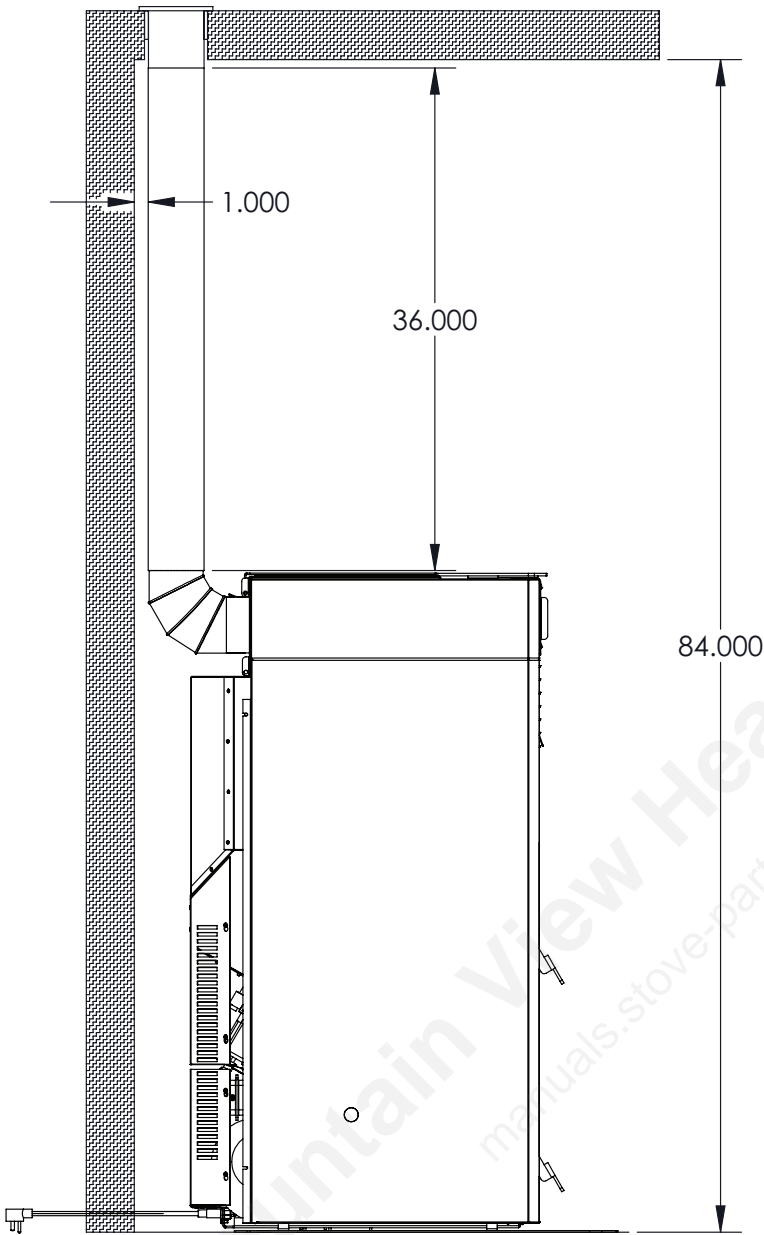

Figure 17: Ducting minimum

Ducting coming from the Heat Distribution Kit must have a one inch clearance to any combustible materials. Ducts must be installed with a minimum 36" vertical section before the register boot. Maximum recommend run would be 20ft with 1-2 elbows, performance will decline as the length is increased and with changes in direction. One of the ducts may be capped off.

Wall and floor registers must be installed with supplied 1/4" insulation between ducting to register adapter and the combustible building materials. Metal registers are required and can not be installed with zero clearance.

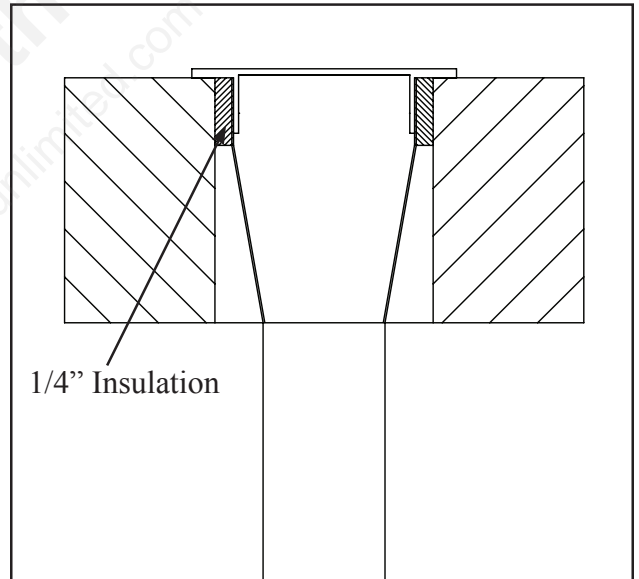

Figure 18: Register install.

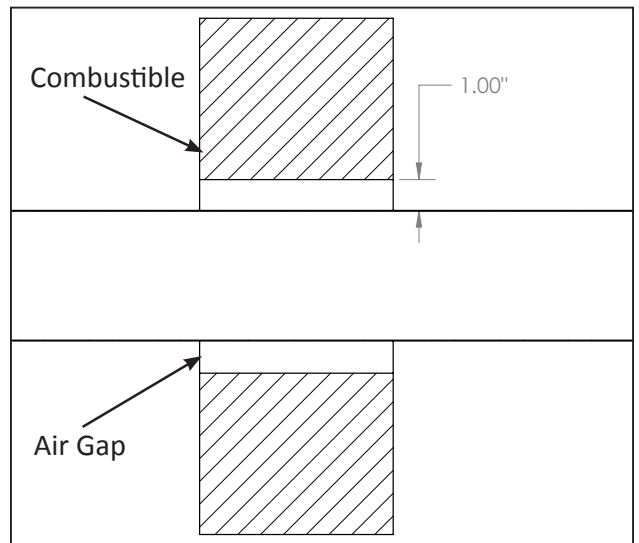

Figure 19: Duct install clearance.

WIRING

DISCONNECT POWER FROM UNIT BEFORE WIRING OR SERVICING

- Check sensor connections are correct. The top sensor should have white wires, middle sensor should have black wires, and the bottom sensor should have grey wires. Route the wires as shown and use the 6" wire ties to secure the harness at the circled screw locations, figure 20. Use other Zip ties to cleanup wiring if needed.
- The grey wires will be wired inline with the High Limit Switch located at the back of the hopper. Disconnect one of the orange wires already attached to the High Limit, now attach one of the grey wires from the HDK to the wire you just disconnected. The other grey wire from the HDK will connect to the High Limit Switch, see figure 22 for high limit location.
- The white wires from the HDK will have no connectors and will be wired to the Thermostat connection on the back side of the circuit board. The circuit board will need to be detached from the frame, a small flat head screw driver will be required to secure the wires, see Figure 21.
- There will be a purple wire coming from the circuit board that is connected to a black wire coming from the convection fan at the rear of the unit, disconnect these wires. One of the black wires from the HDK has a small purple wire connected to it, connect this to purple wire from the circuit board. Connect the black fan wire to the connector that join the black and purple HDK wires.
- Locate where the power cord enters the unit at the back see Figure 23. Disconnect the black wire going to the power cord connection. The other black wire from the HDK will connect to the disconnected wire and the power cord connection. **Note: See page 10 for full wiring diagram.**

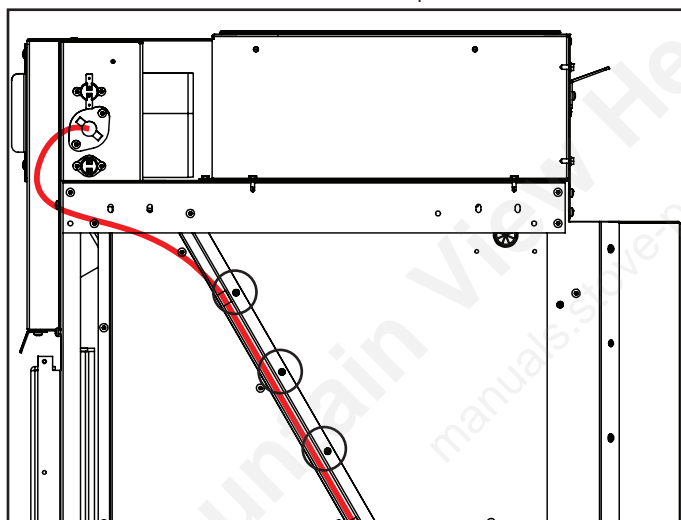

Figure 20: Wiring path

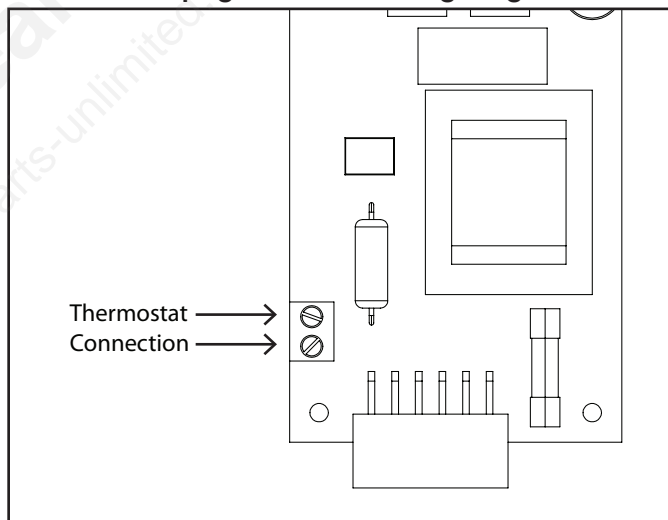

Figure 21: Back of Circuit Board

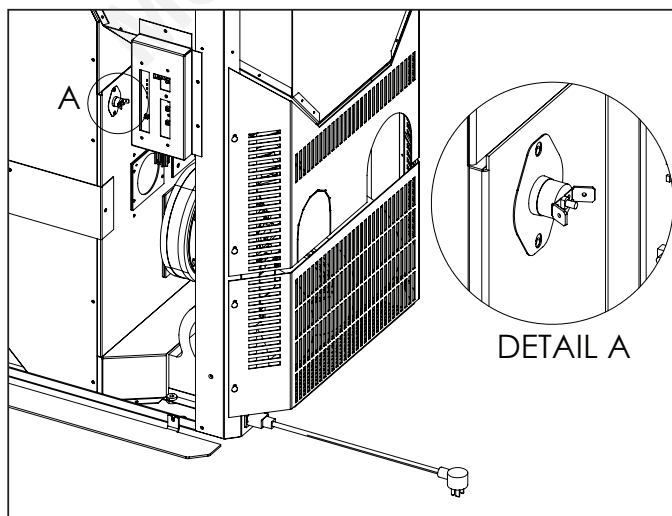

Figure 22: High Limit Switch Detail

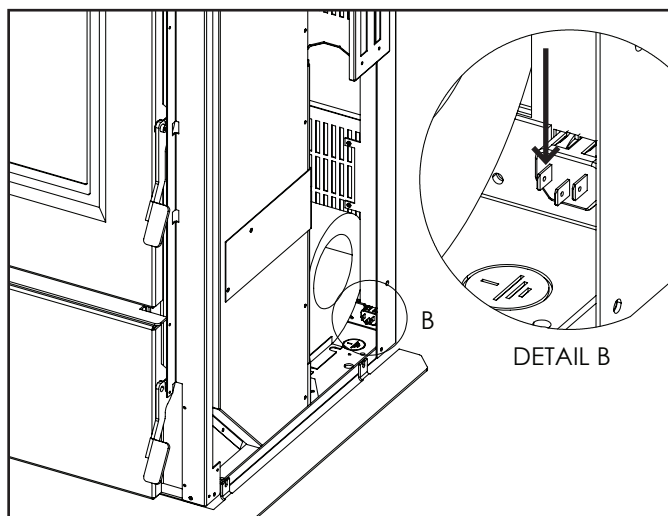
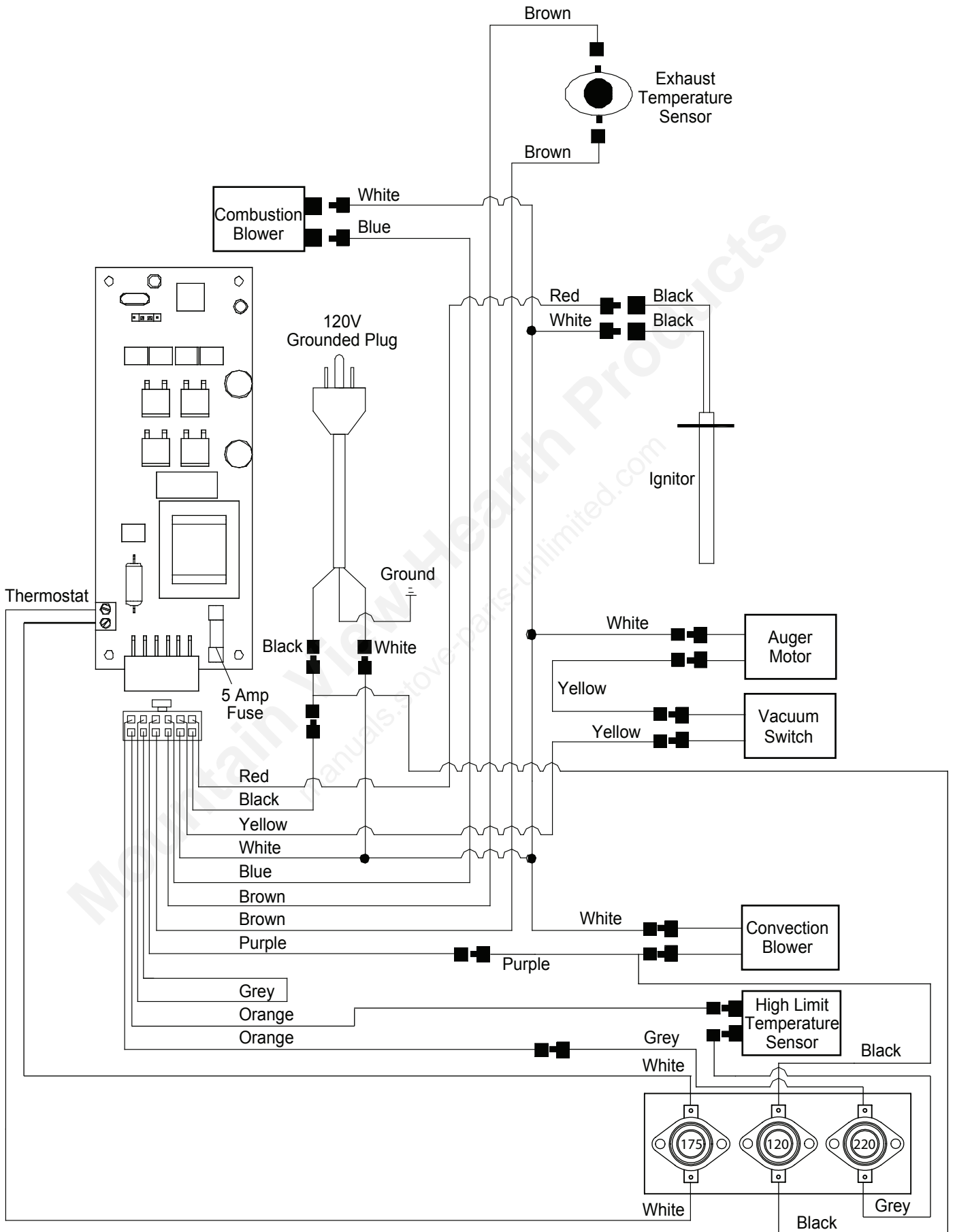

Figure 23: Power Cord Connection Detail

WIRING DIAGRAM



PARTS LIST

PART NO.	DESCRIPTION	REPLACEMENT NO.
1	HDK Back Assembly	
2	HDK Front Assembly	
3	Lid Gasket	EF-208
4	Cabinet Side Extensions	
5	Duct Shields	
6	Adjustable Grill	50-2887
7	Grill	50-2886
8	Air Deflectors	
9	Control Sensor (175F)	EC-002
10	Fan Sensor (120F)	EC-001
11	High Limit Sensor (220F)	50-2888

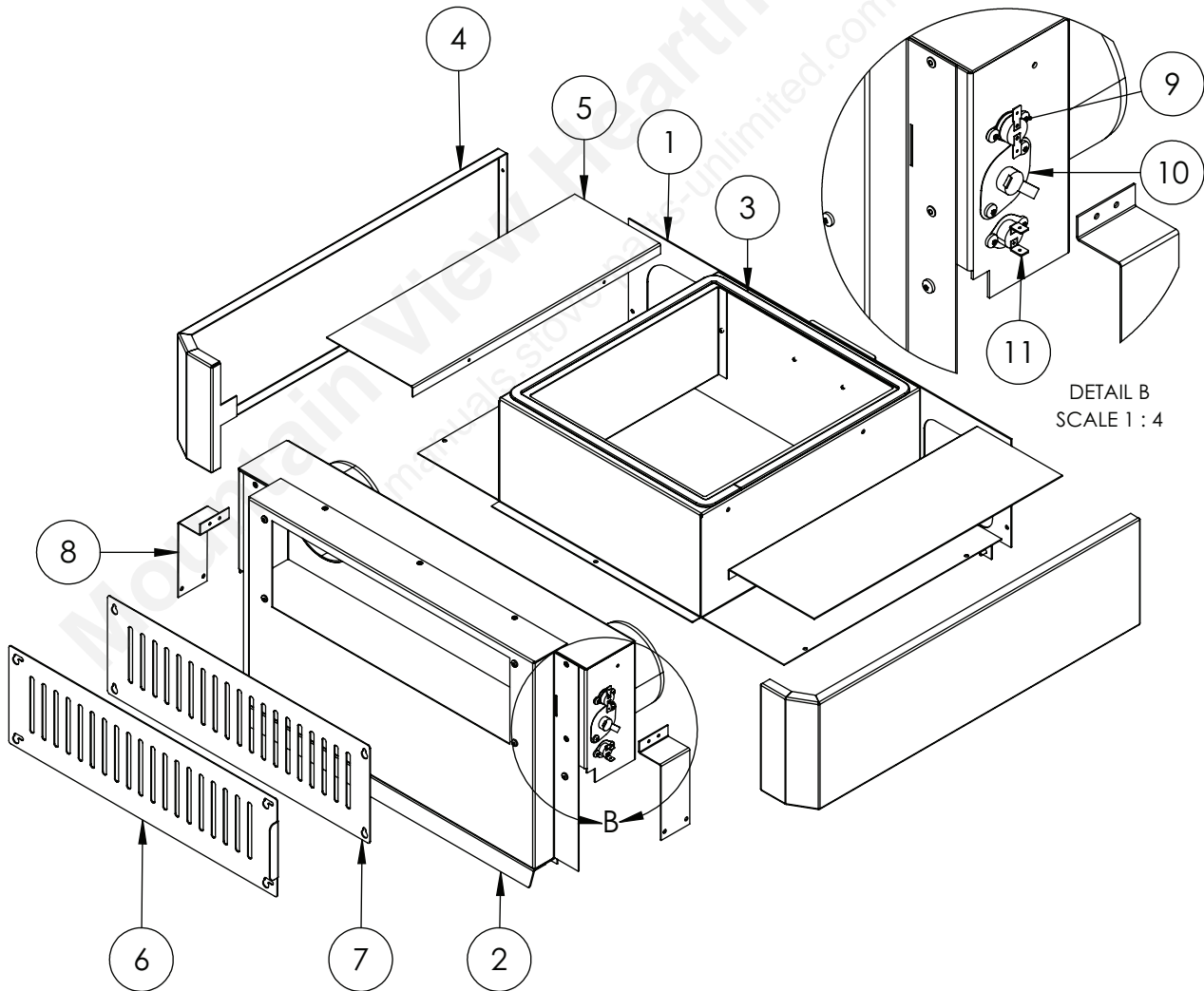

Mountain View Hearth Products
manuals.stove-parts-unlimited.com

MANUFACTURED BY:
SHERWOOD INDUSTRIES LTD.
6782 OLDFIELD RD. SAANICHTON, BC, CANADA V8M 2A3
www.enviro.com
July 17 2015
C-14699