

50-2025 & 50-2026 Hopper Extension Kit

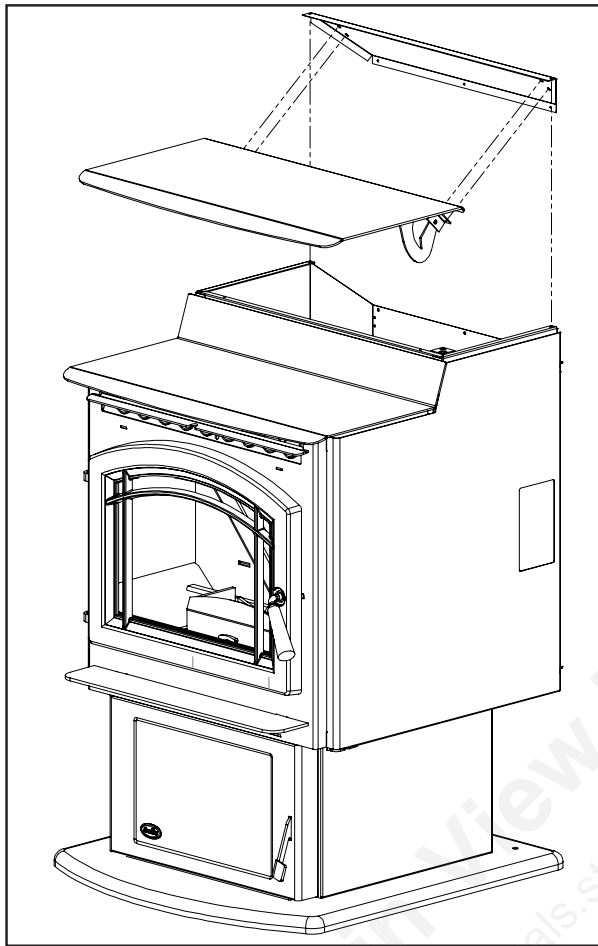

Figure 1: Removing the hopper lid and back top.

4. Remove the three (3) screws on the back of hopper that hold the hopper top back on. Save the hopper top back so the stove can be converted back.
5. Remove the two (2) screws under firebox top that hold the hopper switch on.
6. Mount the hopper lid to the hopper extension and adjust it so it seals on gasket.
7. Mount the hopper extension onto the unit using three (3) screws on the back and two (2) screws on front edge.
8. Mount the hopper switch bracket, route the wires through the grommet in front of the hopper, and hook it up in series with the high limit switch.
9. Check the hopper switch height; it should be about $\frac{1}{16}$ " away from the magnet at the bottom of the hopper lid.

Please ensure that your Hopper Extension Kit has not been damaged and all components are included.

Quantity	Description
12	8-32 x $\frac{3}{8}$ " T-20 Screws
1	Hopper Switch With Extension Wires
1	Hopper Extension
1	Hopper Switch Relocation Bracket

1. Remove the hopper lid by removing four (4) screws on the top back of the hopper.
2. Remove the gasket.
3. Using an $\frac{1}{8}$ " drill remove the two (2) rivets on the top edge of hopper that hold hopper back top on.

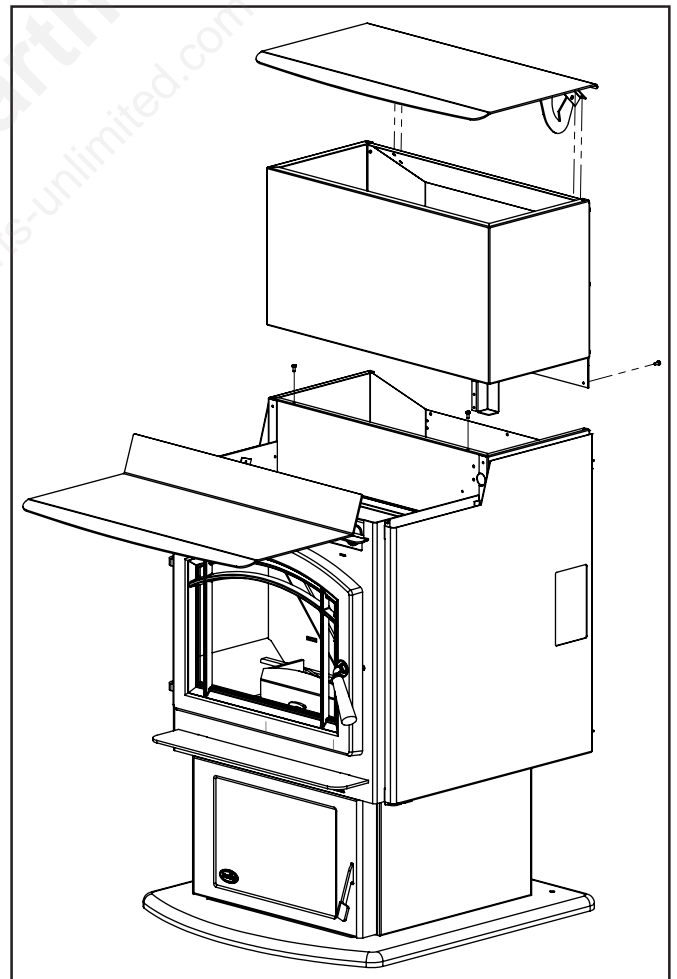

Figure 2: Installing Hopper Extension Kit.

MANUFACTURED BY:
SHERWOOD INDUSTRIES LTD.
6782 OLDFIELD RD. SAANICHTON, BC, CANADA V8M 2A3
August 5, 2009
C-11993