

Owner's Manual

Care and Operation

INSTALLER: Leave this manual with party responsible for use and operation.

OWNER: Retain this manual for future reference.

Contact your local dealer with questions on installation, operation or service.

NOTICE: SAVE THESE INSTRUCTIONS

HARMAN®

BUILT TO A STANDARD, NOT A PRICE

Model(s):

Accentra 52i Pellet Insert

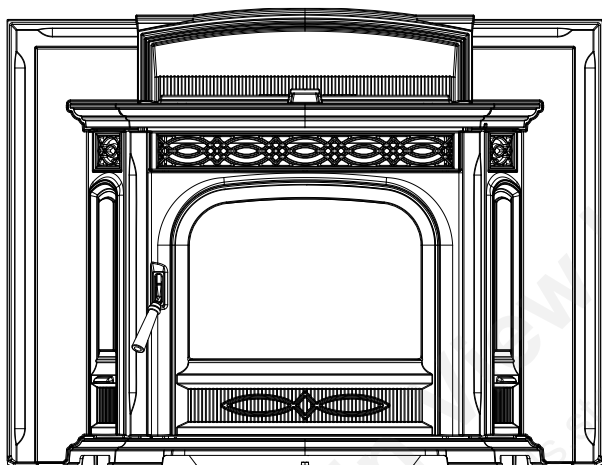

Scan to view
Accentra 52i
Owner's Video



The Harman, Inc. unit
shown is designed for
operation and certified by
professionals who are
certified in the U.S. for
the National Fireplace
Institute (NFI) by the
International



CAUTION

Tested and approved for wood pellets and shelled field corn fuel only. Burning of any other type of fuel voids your warranty.



CAUTION

Check building codes prior to installation.

- Installation **MUST** comply with local, regional, state and national codes and regulations.
- Contact local building or fire officials about restrictions and installation inspection requirements in your area.



WARNING



Please read this entire manual before installation and use of this pellet fuel-burning room heater.

Failure to follow these instructions could result in property damage, bodily injury or even death.

- Do not store or use gasoline or other flammable vapors and liquids in the vicinity of this or any other appliance.
- Do not overfire - If any external part starts to glow, you are overfiring. Reduce feed rate. Overfiring will void your warranty.
- Comply with all minimum clearances to combustibles as specified. Failure to comply may cause house fire.



WARNING



HOT SURFACES!

Glass and other surfaces are hot during operation and cool down.

Hot glass will cause burns.

- Do not touch glass until it is cooled
- **NEVER** allow children to touch glass
- Keep children away
- **CAREFULLY SUPERVISE** children in same room as stove.
- Alert children and adults to hazards of high temperatures.
High temperatures may ignite clothing or other flammable materials.
- Keep clothing, furniture, draperies and other flammable materials away.

NOTE

To obtain a French translation of this manual, please contact your dealer or visit www.harmanstoves.com

Pour obtenir une traduction française de ce manuel, s'il vous plaît contacter votre revendeur ou visitez www.harmanstoves.com

▲ Safety Alert Key:

- **DANGER!** Indicates a hazardous situation which, if not avoided will result in death or serious injury.
- **WARNING!** Indicates a hazardous situation which, if not avoided could result in death or serious injury.
- **CAUTION!** Indicates a hazardous situation which, if not avoided, could result in minor or moderate injury.
- **NOTICE:** Used to address practices not related to personal injury.

Table of Contents

1 Welcome

- A. Congratulations 2
- B. Limited Lifetime Warranty 4-5

2 Product Specific and Important Safety Information

- A. Appliance Certification 6
- B. Mobile Home Approved 6
- C. Glass Specifications (Ceramic) 6
- D. Electrical Rating 6
- E. BTU & Efficiency Specifications 6

3 General Information

- A. Appliance Safety 7
- B. Clear Space 7
- C. Control Explanation 8
- D. Fuel Specification 9
- E. General Operating Information 10

4 Operating Instructions

- A. Starting Your First Fire 11
- B. Fire Characteristics 11
- C. Feed Rate Adjustment Instructions 11
- D. Ignition Cycles 12
- E. Automatic Ignition 13-14
- F. Manual Ignition 15-16

5 Maintenance and Service

- A. Proper Shutdown Procedure 17
- B. Quick Reference Maintenance Chart 17
- C. General Maintenance 17
- D. Glass Maintenance 18
- E. Burnpot Maintenance 19
- F. Combustion Blower Chamber 20
- G. Pellet Feeder Chamber 21

6 Troubleshooting and Frequently Asked Questions

- A. Error Code Description 22
- B. Frequently Asked Questions 23
- C. Troubleshooting 24

7 Reference Materials

- A. Safety Reminders 25
- B. Motor and Component Location 26
- C. Loss of Power 27
- D. Service Parts 28
- E. Contact Information 34

➔ = Contains updated information

B. Limited Lifetime Warranty

Hearth & Home Technologies LIMITED LIFETIME WARRANTY

Hearth & Home Technologies, on behalf of its hearth brands ("HHT"), extends the following warranty for HHT gas, wood, pellet, coal and electric hearth appliances that are purchased from an HHT authorized dealer.

WARRANTY COVERAGE:

HHT warrants to the original owner of the HHT appliance at the site of installation, and to any transferee taking ownership of the appliance at the site of installation within two years following the date of original purchase, that the HHT appliance will be free from defects in materials and workmanship at the time of manufacture. After installation, if covered components manufactured by HHT are found to be defective in materials or workmanship during the applicable warranty period, HHT will, at its option, repair or replace the covered components. HHT, at its own discretion, may fully discharge all of its obligations under such warranties by replacing the product itself or refunding the verified purchase price of the product itself. The maximum amount recoverable under this warranty is limited to the purchase price of the product. This warranty is subject to conditions, exclusions and limitations as described below.

WARRANTY PERIOD:

Warranty coverage begins on the date of original purchase. In the case of new home construction, warranty coverage begins on the date of first occupancy of the dwelling or six months after the sale of the product by an independent, authorized HHT dealer/ distributor, whichever occurs earlier. The warranty shall commence no later than 24 months following the date of product shipment from HHT, regardless of the installation or occupancy date. The warranty period for parts and labor for covered components is produced in the following table.

The term "Limited Lifetime" in the table below is defined as: 20 years from the beginning date of warranty coverage for gas appliances, and 10 years from the beginning date of warranty coverage for wood, pellet, and coal appliances. These time periods reflect the minimum expected useful lives of the designated components under normal operating conditions.

Warranty Period		HHT Manufactured Appliances and Venting							Components Covered
Parts	Labor	Gas	Wood	Pellet	EPA Wood	Coal	Electric	Venting	
1 Year		X	X	X	X	X	X	X	All parts and material except as covered by Conditions, Exclusions, and Limitations listed
2 years				X	X	X			Igniters, electronic components, and glass
		X	X	X	X	X			Factory-installed blowers
			X						Molded refractory panels
3 years				X					Firepots and burnpots
5 years	1 year			X	X				Castings and baffles
7 years	3 years		X	X	X				Manifold tubes, HHT chimney and termination
10 years	1 year	X							Burners, logs and refractory
Limited Lifetime	3 years	X	X	X	X	X			Firebox and heat exchanger
90 Days		X	X	X	X	X	X	X	All replacement parts beyond warranty period

See conditions, exclusions, and limitations on next page.

B. Limited Lifetime Warranty (*continued*)

WARRANTY CONDITIONS:

- This warranty only covers HHT appliances that are purchased through an HHT authorized dealer or distributor. A list of HHT authorized dealers is available on the HHT branded websites.
- This warranty is only valid while the HHT appliance remains at the site of original installation.
- This warranty is only valid in the country in which the HHT authorized dealer or distributor that sold the appliance resides.
- Contact your installing dealer for warranty service. If the installing dealer is unable to provide necessary parts, contact the nearest HHT authorized dealer or supplier. Additional service fees may apply if you are seeking warranty service from a dealer other than the dealer from whom you originally purchased the product.
- Check with your dealer in advance for any costs to you when arranging a warranty call. Travel and shipping charges for parts are not covered by this warranty.

WARRANTY EXCLUSIONS:

This warranty does not cover the following:

- Changes in surface finishes as a result of normal use. As a heating appliance, some changes in color of interior and exterior surface finishes may occur. This is not a flaw and is not covered under warranty.
- Damage to printed, plated, or enameled surfaces caused by fingerprints, accidents, misuse, scratches, melted items, or other external sources and residues left on the plated surfaces from the use of abrasive cleaners or polishes.
- Repair or replacement of parts that are subject to normal wear and tear during the warranty period. These parts include: paint, wood, pellet and coal gaskets, firebricks, grates, flame guides, batteries and the discoloration of glass.
- Minor expansion, contraction, or movement of certain parts causing noise. These conditions are normal and complaints related to this noise are not covered by this warranty.
- Damages resulting from: (1) failure to install, operate, or maintain the appliance in accordance with the installation instructions, operating instructions, and listing agent identification label furnished with the appliance; (2) failure to install the appliance in accordance with local building codes; (3) shipping or improper handling; (4) improper operation, abuse, misuse, continued operation with damaged, corroded or failed components, accident, or improperly/incorrectly performed repairs; (5) environmental conditions, inadequate ventilation, negative pressure, or drafting caused by tightly sealed constructions, insufficient make-up air supply, or handling devices such as exhaust fans or forced air furnaces or other such causes; (6) use of fuels other than those specified in the operating instructions; (7) installation or use of components not supplied with the appliance or any other components not expressly authorized and approved by HHT; (8) modification of the appliance not expressly authorized and approved by HHT in writing; and/or (9) interruptions or fluctuations of electrical power supply to the appliance.
- Non-HHT venting components, hearth components or other accessories used in conjunction with the appliance.
- Any part of a pre-existing fireplace system in which an insert or a decorative gas appliance is installed.
- HHT's obligation under this warranty does not extend to the appliance's capability to heat the desired space. Information is provided to assist the consumer and the dealer in selecting the proper appliance for the application. Consideration must be given to appliance location and configuration, environmental conditions, insulation and air tightness of the structure.

This warranty is void if:

- The appliance has been over-fired or operated in atmospheres contaminated by chlorine, fluorine, or other damaging chemicals. Over-firing can be identified by, but not limited to, warped plates or tubes, rust colored cast iron, bubbling, cracking and discoloration of steel or enamel finishes.
- The appliance is subjected to prolonged periods of dampness or condensation.
- There is any damage to the appliance or other components due to water or weather damage which is the result of, but not limited to, improper chimney or venting installation.

LIMITATIONS OF LIABILITY:

- The owner's exclusive remedy and HHT's sole obligation under this warranty, under any other warranty, express or implied, or in contract, tort or otherwise, shall be limited to replacement, repair, or refund, as specified above. In no event will HHT be liable for any incidental or consequential damages caused by defects in the appliance. Some states do not allow exclusions or limitation of incidental or consequential damages, so these limitations may not apply to you. This warranty gives you specific rights; you may also have other rights, which vary from state to state. EXCEPT TO THE EXTENT PROVIDED BY LAW, HHT MAKES NO EXPRESS WARRANTIES OTHER THAN THE WARRANTY SPECIFIED HEREIN. THE DURATION OF ANY IMPLIED WARRANTY IS LIMITED TO DURATION OF THE EXPRESSED WARRANTY SPECIFIED ABOVE.

2 Product Specific and Important Safety Information

A. Appliance Certification

MODEL:	Accentra 52i Pellet Insert
LABORATORY:	OMNI Test Laboratories, Inc
REPORT NO.	135-S-31-2
TYPE:	Pellet Fueled Insert/Supplementary For Residential Use
STANDARD(s):	ASTM E1509-12, ULC-S628-93

NOTE: This installation must conform with local codes. In the absence of local codes you must comply with the ASTM E1509-12, ULC-S628-93 & **(UM) 84-HUD**

The Accentra 52i Pellet Insert by Harman® is exempt from Environmental Protection Agency certification under 40 CFR 60.531 by definition [Wood Heater (A) "Air to Fuel Ratio"].

B. Mobile Home Approved

This appliance is approved for mobile home installations when not installed in a sleeping room and when an outside combustion air inlet is provided.

The structural integrity of the mobile home floor, ceiling, and walls must be maintained. The appliance must be properly grounded to the frame of the mobile home and use only listed pellet vent, Class "PL" connector pipe.

A Harman® Outside Air Kit must be installed in a mobile home installation.



CAUTION

THE STRUCTURAL INTEGRITY OF THE MANUFACTURED HOME FLOOR, WALL, AND CEILING/ ROOF MUST BE MAINTAINED.



WARNING

DO NOT INSTALL IN SLEEPING ROOM.

C. Glass Specifications

This appliance is equipped with 5mm ceramic glass. Replace glass only with 5mm ceramic glass. Please contact your dealer for replacement glass.

D. Electrical Rating

120 VAC, 60 Hz, Start 5.0 Amps, Run 4.0 Amps

NOTE: Some generator or battery back-up systems may not be compatible with the micro-processor electronics on this appliance. Please consult the power supply manufacturer for compatible systems.

E. BTU & Efficiency Specifications

Particulate Emissions Rating:	N/A
*BTU Output:	8,000 - 52,000 / hr
Heating Capacity:	up to 2,300 sq. ft. depending on climate zone
Hopper Capacity:	64.5 lbs
Fuel:	Wood Pellets or Shelled Corn
Shipping Weight:	475 lbs

*BTU output will vary, depending on the brand of fuel you use in your appliance. Consult your Harman® dealer for best results.

WARNING! Risk of Fire! *Hearth & Home Technologies disclaims any responsibility for, and the warranty and agency listing will be voided by the below actions.*

DO NOT:

- Install or operate damaged appliance
- Modify appliance
- Install other than as instructed by *Hearth & Home Technologies*
- Operate the appliance without fully assembling all components
- Overfire
- Install any component not approved by *Hearth & Home Technologies*
- Install parts or components not Listed or approved.
- Disable safety switches

Improper installation, adjustment, alteration, service or maintenance can cause injury or property damage.

For assistance or additional information, consult a qualified installer, service agency or your dealer.



NOTE: *Hearth & Home Technologies, manufacturer of this appliance, reserves the right to alter its products, their specifications and/or price without notice.*

Harman® is a registered trademark of *Hearth & Home Technologies.*

3 General Information

A. Appliance Safety

WARNING! DO NOT operate stove before reading and understanding operating instructions. Failure to operate stove according to operating instructions could cause fire or injury.

 WARNING	
	HOT SURFACES! Glass and other surfaces are hot during operation and cool down. Hot glass will cause burns.
	<ul style="list-style-type: none">• DO NOT touch glass until it is cooled• NEVER allow children to touch glass• Keep children away
<ul style="list-style-type: none">• CAREFULLY SUPERVISE children in same room as stove.• Alert children and adults to hazards of high temperatures.	
High temperatures may ignite clothing or other flammable materials.	
<ul style="list-style-type: none">• Keep clothing, furniture, draperies and other flammable materials away.	

If you expect that small children or vulnerable adults may come into contact with this appliance, the following precautions are recommended:

- Install a physical barrier such as:
 - A decorative fire screen.
 - Adjustable safety gate.
- Never leave children alone near a hot stove, whether operating or cooling down.
- Teach children to NEVER touch the stove.
- Consider not using the stove when children will be present.

Contact your dealer for more information, or visit: www.hpba.org/safety-information.

To prevent unintended operation when not using your stove for an extended period of time (summer months, vacations, trips, etc):

- Unplug stove from receptical.

B. Clear Space

WARNING! RISK OF FIRE! Do NOT place combustible objects in front or to the sides of the appliance. High temperatures may ignite clothing, furniture or draperies.

Mantel: Avoid placing candles and other heat-sensitive objects on mantel or hearth. Heat may damage these objects.

NOTICE: Clearances may only be reduced by means approved by the regulatory authority having jurisdiction.

WARNING! RISK OF FIRE! Keep combustible materials, gasoline and other flammable vapors and liquids clear of appliance.

- Do NOT store flammable materials in the appliance's vicinity.
- Do NOT use gasoline, lantern fuel, kerosene, charcoal lighter fluid or similar liquids to start or "freshen up" a fire in this heater.

Keep all such liquids well away from the heater while it is in use as combustible materials may ignite.

C. Control Explanation

Power Light

Indicates power to the control.

Status Light

Will be lit in either stove or room temp mode when pointer is not within off position band except after normal shut down.

Indicates power to distribution blower.

Indicates power to combustion blower

Indicates power to the feed motor.

Indicates igniter is on.

Temp dial

Allows you to adjust the room temperature setting, in Room Temp Mode, using the outer scale marked in degrees Fahrenheit. It also allows you to adjust the stove temperature setting, while in Stove Temp Mode, using the inner scale marked from 1 to 7.

Dealer Diagnostic Port

For dealer maintenance only. Requires special DDM monitor supplied to Harman® Dealers exclusively.

Mode Selector

Allows you to choose between Room Temp Mode, Stove Temp Mode, or OFF. Also allows you to vary the distribution blower speed by turning the knob to the high or low side of each mode.

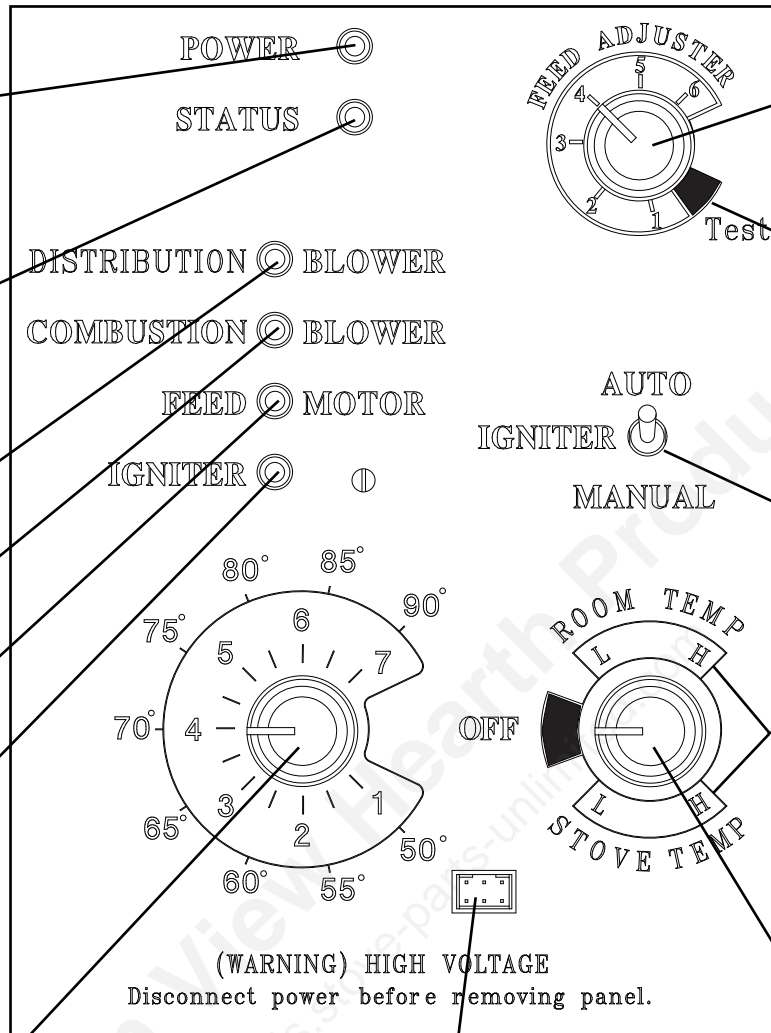

Feed adjuster

Sets the maximum feed rate

Test

Runs all motors at full speed for one minute to check operation. Afterwards the control will simulate a minimum burn with the combustion blower remaining on low.

Igniter switch

Set to appropriate Start-Up mode.

Distribution Blower speed adjustment range.

L = low

H = high

Variable speed anywhere between L and H; although as the stove temp. goes up, so does the L and H scale.

D. Fuel Specifications

Fuel and Fuel Storage

Pellet fuel quality can fluctuate from manufacturer to manufacturer, and even from bag to bag.

Hearth & Home Technologies recommends using only fuel that is certified by the Pellet Fuels Institute (PFI).

Fuel Material

- Made from sawdust and/or other wood by-products
- Shelled field corn (must be mixed with up to 50% wood pellets)
- Source material typically determines ash content

Higher Ash Content Material

- Hardwoods with high mineral content
- Bark and leaves as source material
- "Standard" grade pellets, corn and other biomass

Lower Ash Content Material

- Softwood; pine, fir, etc.
- Materials with lower mineral content
- "Premium" grade pellets

Shelled field corn

- Must be 15% moisture content or less
- Must be clean and free of debris
- Must be mixed with wood pellets. (Up to 50%)
- Stalk parts, excessive fines and cob remnants may cause feed system jams or blockage

CAUTION! Do not burn fuel that contains an additive; (such as soybean oil)

- May cause hopper fire
- Damage to product may result

Read the list of ingredients on the packaging. If you are buying field corn, the only ingredient listed should be field corn.

WARNING! Risk of Chemical Poisoning!

Do **NOT** burn treated seed corn

- Chemical pesticides are harmful or fatal if swallowed
- Burning treated seed corn will void the product warranty

Clinkers

Minerals and other non-combustible materials, like sand, will turn into a hard glass-like substance when heated.

Trees from different areas will vary in mineral content. For this reason, some fuels will produce more clinkers than others.

Moisture

Always burn dry fuel. Burning fuel with high moisture content takes energy to dry and tends to cool the appliance thus, robbing heat from your home. Damp pellet fuel could turn back into sawdust which does not flow properly through the feed system.

Size

- Pellets are either 1/4 inch or 5/16 inch (6-8mm) in diameter
- Length should be no more than 1-1/2 inches (38mm)
- Pellet length can vary from lot to lot from the same manufacturer.

Performance

- Higher ash content requires more frequent maintenance.
- "Premium" grade pellets will produce the highest heat output.
- Burning pellets longer than 1-1/2 inches (38mm) can cause inconsistent feeding and/or ignition.

We recommend that you buy fuel in multi-ton lots whenever possible. However, we do recommend trying different brands prior to purchasing multi-ton lots, to ensure your satisfaction.

CAUTION! Tested and approved for use with wood pellets and up to a 50% mixture of shelled field corn and wood pellets ONLY. Burning of any other fuel will void your warranty.

When changing from wood pellets to a corn/pellet mixture, the FEED ADJUSTER will likely need adjusted to a lower setting. When under maximum demand, ensure there is no unburned fuel being pushed into the ash pan.

Storage

- Wood pellets should be left in their original sealed bag until ready to use, to prevent moisture.
- Shelled corn should be stored in a tightly sealed container to prevent moisture and to deter pests
- Do not store fuel within the specified clearance areas, or in a location that will interfere with routine cleaning and maintenance procedures.



CAUTION

Tested and approved for use with wood pellets and a 50% mixture of shelled field corn and wood pellets ONLY. Burning of any other fuel will void your warranty.

NOTICE

Hearth & Home Technologies is not responsible for stove performance or extra maintenance required as a result of using fuel with higher ash or mineral content.

E. General Operating Information

Room Sensor

The appliance is like most modern furnaces; when the room sensor calls for heat, your appliance will automatically light and deliver heat.

When the room is up to temperature and the room sensor is satisfied, the appliance will shut down.

Heat Output Controls

The appliance will turn on and off as the room sensor demands. When the room sensor calls for heat, the appliance will always start up on High. After burning approximately 7-10 minutes, the appliance will then burn at the rate at which it was originally set. If the appliance is set at one of the lower settings, it will run quieter but take longer to heat up an area than if it were set at a higher burn rate.

Regardless of the burn rate, when the area is warm enough to satisfy the room sensor, the appliance will shut off.

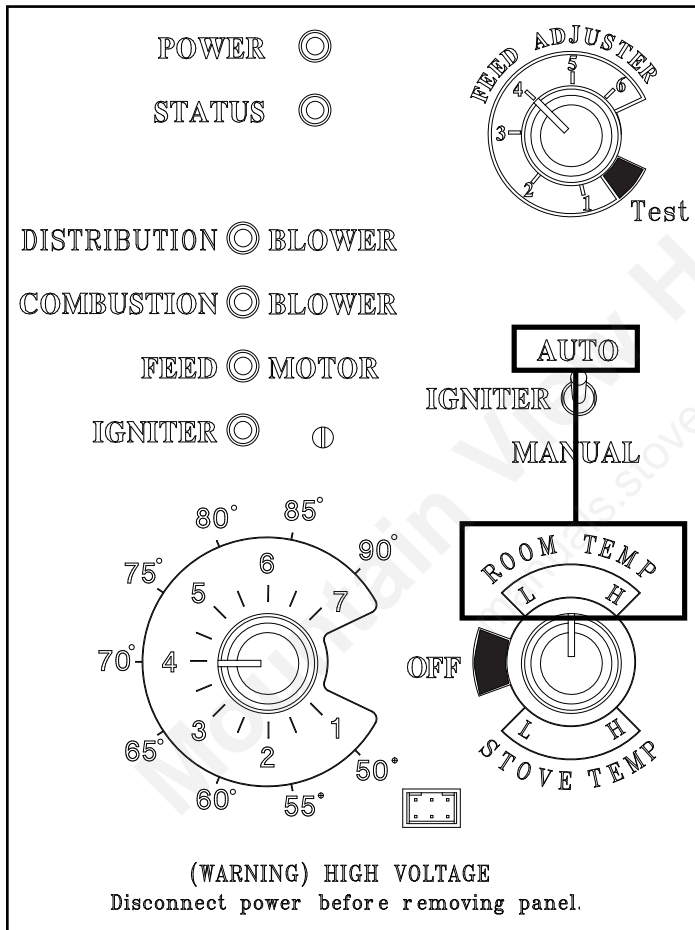

Figure 3.1

WARNING



Fire Hazard

Keep combustible materials, gasoline and other flammable vapors and liquids clear of appliance.

- Do NOT store flammable materials in the appliance's vicinity.
- NEVER USE GASOLINE, GASOLINE-TYPE LANTERN FUEL, KEROSENE, CHARCOAL LIGHTER FLUID, OR SIMILAR LIQUIDS TO START OR "FRESHEN UP" A FIRE IN THIS HEATER. KEEP ALL SUCH LIQUIDS WELL AWAY FROM THE HEATER WHILE IT IS IN USE.
- DO NOT BURN GARBAGE OR FLAMMABLE FLUIDS SUCH AS GASOLINE, NAPHTHA OR ENGINE OIL.
- DO NOT USE CHEMICALS OF FLUIDS TO START THE FIRE.
- Combustible materials may ignite.

Before Your First Fire

1. First, make sure your appliance has been properly installed and that all safety requirements have been met. Pay particular attention to the fire protection and venting instructions.
2. Double check that the ash pan and firebox are empty!
3. Close the front door.

4 Operating Instructions

A. Starting Your First Fire

1. A room sensor is required for proper operation of this appliance in “Room Temp” mode. At this time, fill the hopper with pellets, ensure the control is set to “OFF”. Figure 4.2. Plug the power cord into a properly grounded, nearby outlet.
2. Once power is present, the unit will run through a quick diagnostics test to insure the control is operating properly. This is normal.
3. For your first fire it may be necessary to purge the auger system by putting the feed adjuster knob to “Test” prior to starting the unit. Figure 4.3. This insures that plenty of fuel enters the burn pot for proper ignition.
4. Flip toggle switch to desired mode “auto or manual”. Figure 4.4. Set feed adjuster knob to desired setting and turn mode dial to “Room Temp” or “Stove Temp” Figure 4.5.
Note: Feed rate of #4 is a good starting point. Adjustments may need to be made depending on fuel quality and/or heat output desired.
5. The fuel feed system and the igniter should now be on.
6. Once the appliance has ignited, let it burn for approximately 7-10 minutes. After this time, the igniter light should turn off and the unit should begin to operate per the settings at the control.

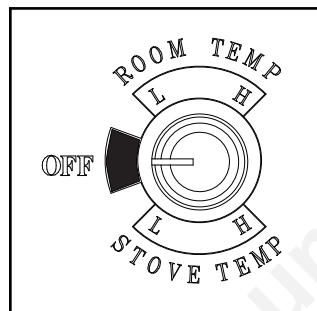

Figure 4.2

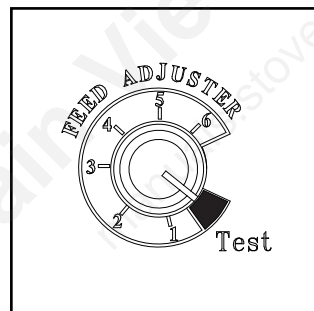

Figure 4.3

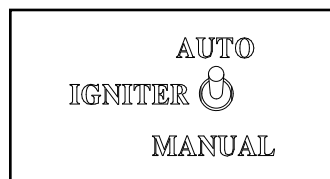

Figure 4.4

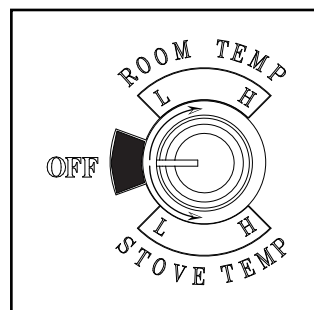

Figure 4.5

B. Fire Characteristics

A properly adjusted fire has an active flame pattern.

C. Feed Rate Adjustment Instructions

The feed adjustment control is factory set at #4, and should be adequate for most fuels.

However, if the flame height is too high or too low, you will need to adjust the feed rate. Wait until the appliance has been burning for 15 minutes before making your adjustments and allow 15 minutes for feed adjustment to take effect.



CAUTION

Odors and vapors released during initial operation.

- Curing of high temperature paint.
- Open windows for air circulation.

Odors may be irritating to sensitive individuals.

D. Ignition Cycles

1. At the beginning of each ignition cycle, it is normal to see some smoke in the firebox. The smoke will stop once the fire starts.
2. The distribution blower will automatically turn on after your appliance has reached the set temperature.

This blower transfers heat from your appliance into the room, and will continue to run in both “room temp” and “stove temp” mode at the speed you have the control knob set to.

3. Occasionally the appliance may run out of fuel and shut itself down. When this happens, the unit will need to be turned to the off position and restarted. If needed, follow the instructions on “Starting Your First Fire” section of this manual.



WARNING



Fire Risk

Do NOT operate appliance:

- With appliance door open.
- Hopper Lid open.

Do NOT store fuel:

- Closer than required clearances to combustibles to appliance
- Within space required for loading or ash removal.

E. Automatic Ignition

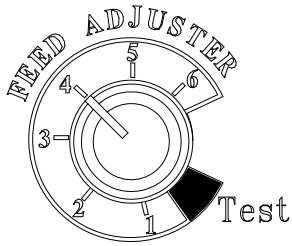

Figure 4.6

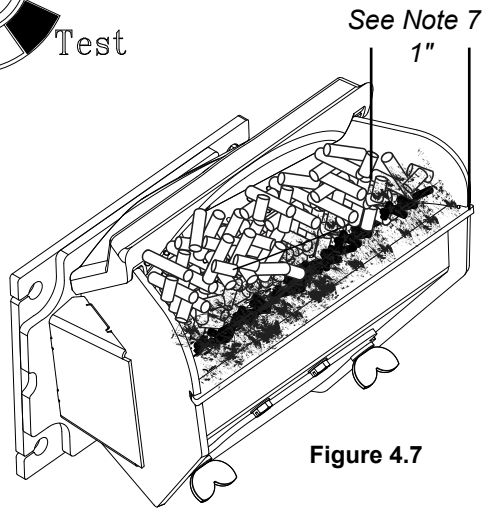

Figure 4.7

1. Fines are small pieces of broken pellets (sawdust). Fines do not flow easily and often build up on the hopper funnel bottom angles. These fines can be pushed into the feeder opening and then fill the hopper with pellets. As the system works, they will be burned.
2. The "TEST" cycle will operate the feed motor for exactly one minute. Turning to "TEST" again and again may load too much fuel into the burn pot causing excessive smoke on start-up.
3. The firebox low pressure switch will not allow the auger motor or the igniter element to operate if the view door is open.
4. Adjust Feed Rate. If this is your first fire or you are trying different pellets, set the feed adjuster to #4, Figure 4.6 This is a conservative number and will probably need to be increased. After you know a feed rate setting that works well, use that setting. Remember, if your feed rate is too high you may waste fuel.
5. This is usually a weekly maintenance procedure. Cleaning the burn pot with the scraper with a small amount of new fuel in the bottom is not a problem. First, scrape the ashes off the front of the burn pot into the ash pan. Then scrape the holed surface downward into the burn pot. When the stove feeds, these scrapings will be pushed out by the feeder.
6. The ash pan can hold the ashes from approximately 10 bags of premium fuel.
7. Setting the feed adjuster # for maximum burn: With the unit burning in "AUTO", turn to "Stove Mode" and put the fan on "H". Set the Temperature Dial to #7. Allow the unit to burn for about 30 minutes and check ash on front of burn pot. Figure 4.7. If the ash line is larger than 1", turn the feed adjuster from #4 to #5. Allow another 30 minutes of burn time and check again. If, at #6 setting, a 1" or less ash bed is not obtainable, it is not a problem. The 1" ash bed is only at maximum burn rate and during normal operation, the ash bed will be larger.

Igniter Switch to "AUTO" (up position)

Make sure the unit is plugged into a properly grounded, 120 VAC, 60 Hz electrical source. The power light should be the only light lit.

Note: Be sure there is no fuel or other combustibles in the ash pan prior to lighting.

1. Turn Mode Selector to "OFF".
2. Fill hopper with pellets.
3. Clean burn pot with scraper, if necessary.
4. If starting after an empty hopper, turn Feed Adjuster to "TEST" (for one 60 second cycle). This will flow pellets into the auger tube and also allow you to check the motors for operation.

NOTE: The auger motor will not operate with the view door open.

5. Turn Feed Adjuster to #4.
6. Flip the Igniter Switch up into the "AUTO" position.
7. Turn the Temperature Dial to the desired room temperature.
8. Turn Mode Selector to Room Temperature or Stove Temperature.
9. Fill hopper with pellets and remove ashes as required. Keep the hopper lid and firebox doors closed while in operation. Failure to do so will affect operation of the appliance and may permit escape of smoke or gases into the living space.



WARNING

BURNING GARBAGE, USE OF IMPROPER FUELS, FIRE STARTERS OR ALTERING THE STOVE FOR HIGHER HEAT OUTPUT MAY CAUSE DAMAGE TO THE STOVE AND COULD RESULT IN A HOUSE FIRE. USE ONLY APPROVED FUELS AND FOLLOW ONLY THESE OPERATION GUIDELINES.



WARNING

NEVER USE GASOLINE, GASOLINE-TYPE LANTERN FUEL, KEROSENE, CHARCOAL LIGHTER FLUID, OR SIMILAR LIQUIDS TO START OR 'FRESHEN UP' A FIRE IN THIS HEATER. KEEP ALL SUCH LIQUIDS WELL AWAY FROM THE HEATER, WHILE IN USE.

E. Automatic Ignition (Continued)

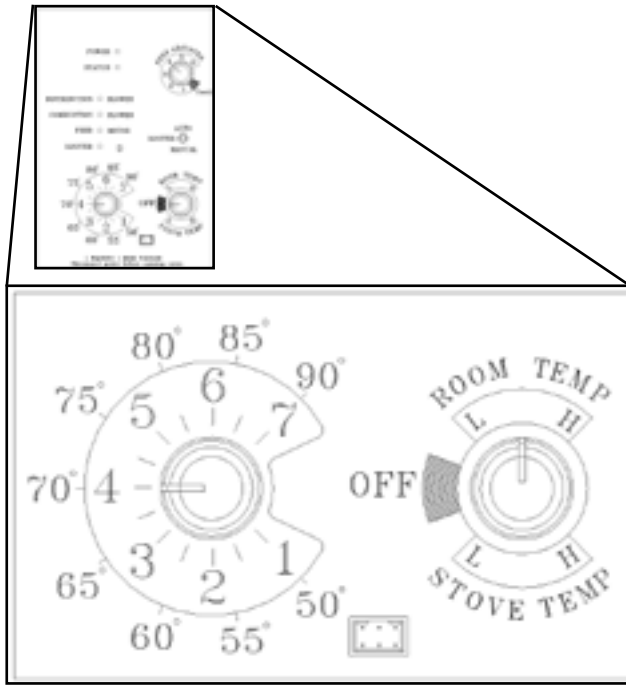

Room Temperature Mode: This setting will produce a room temperature of 70 degrees with the distribution blower at medium speed.

Stove Temperature Mode

This setting will produce medium heat with the distribution blower on "low".

This setting will produce continuous maximum heat output with the distribution blower at full speed.

The Accentra 52i Pellet Insert is more than just automatic ignition, it is also automatic temperature control. The automatic system will allow the fire size to be adjusted to match the heating needs and even put the fire out if necessary. If heat is needed after the fire is out, the Pellet Insert will automatically re-ignite and adjust the fire size to match the heating need. The totally automatic room sensor mode is recommended because of its efficiency. The unit can be switched between "AUTO" and "MANUAL" at any time during operation.

Igniter switch to "AUTO"

Room Temperature Mode

In "Room Temp Mode" heat output is controlled automatically by the Room Sensing Probe. When the Room Sensing Probe calls for heat, the stove will increase output. When the Room Sensing Probe is getting close to the set temperature, the stove will begin to level off output and keep the fire burning at just the right temperature to maintain that setting.

High output is determined by the feed rate setting. This setting, generally on #4, can be increased if higher burn rates are necessary (Figure 4.6). The unit's maximum burn rate should not create less than 1" of ash on the burn pot front edge (Figure 4.7). Overfeeding is not a safety concern, but fuel may be wasted if unburned pellets fall into the ash pan.

In "Room Temp Mode" a constant fuel consumption rate is sacrificed for exact room temperature. Therefore, as it gets colder more pellets will be burned automatically.

The distribution blower speed will vary according to the position of the mode selector pointer and fire size.

Igniter switch to "AUTO"

Stove Temperature Mode

This allows for automatic ignition upon start-up only. The unit can then be set at any desired setting. The heat output and fuel consumption will remain constant regardless of room temperature. The unit's maximum feed rate should not create less than 1" of ash on the burn pot front edge. Figure 4.7.

The unit's low burn or maintenance setting is as low as it will go. It will not go out unless it runs out of fuel or is turned off.

Shut-Down Procedure

To kill the fire or stop burning the stove, turn the Mode Selector to "OFF". This will cause the fire to diminish and burn out. When the fire burns out and the stove cools down everything will stop.

If you pull the plug to shut down the stove, all motors will stop. This may cause incomplete combustion and smoke in the firebox. If the load door is opened, the smoke may escape.

NOTE: At the end of the season the best way to shut down the stove is simply let it run out of pellets, then the stove will shut down automatically.

F. Manual Ignition

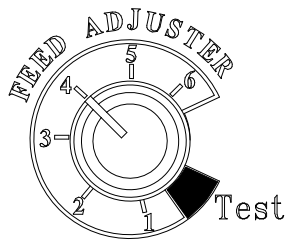

Figure 4.8

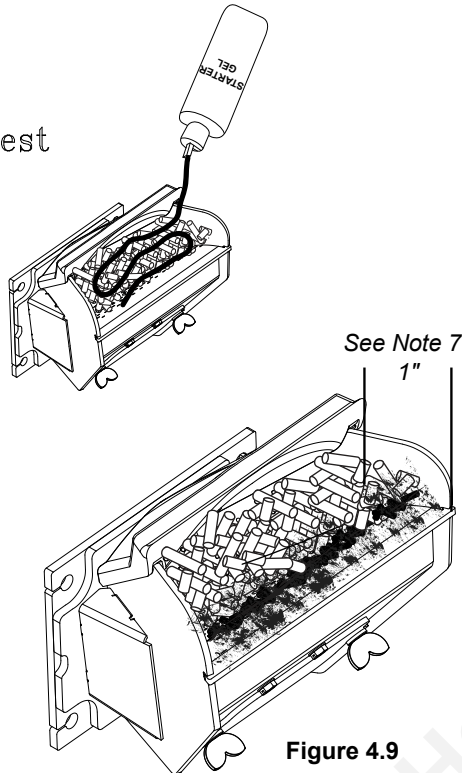

Figure 4.9

1. *Fines are small pieces of broken pellets (sawdust). Fines do not flow easily and often build up on the hopper funnel bottom angles. These fines can be pushed into the feeder opening and then fill the hopper with pellets. As the system works, they will be burned.*
2. *The "TEST" cycle will operate the feeder motor for exactly one minute. Turning to "TEST" again and again may load too much fuel into the burn pot causing excessive smoke on start-up.*
3. *The low pressure switch will not allow the feed motor to operate if the viewing door is open.*
4. *Adjust Feed Rate. If this is your first fire or you are trying different pellets, set the feed adjuster to #4, Figure 4.8. This is a conservative number and will probably need to be increased. After you know a feed rate setting that works well, use that setting. Remember, if your feed rate is too high you may waste fuel.*
5. **Setting the feed adjuster # for maximum burn:** *With the unit burning in "AUTO", turn to "Stove Mode" and put the fan on "H". Set the Temperature Dial to #7. Allow the unit to burn for about 30 minutes and check ash on front of burn pot. Figure 4.9. If the ash line is larger than 1", turn the feed adjuster from #4 to #5. Allow another 30 minutes of burn time and check again. If , at #6 setting, a 1" or less ash bed is not obtainable, it is not a problem. The 1" ash bed is only at maximum burn rate and during normal operation, the ash bed will be larger.*

Igniter Switch to "MANUAL" (down position) Make sure the unit is plugged into a 120 VAC, 60 Hz electrical source. The power light should be the only light lit.

NOTE: Be sure there is no fuel or other combustibles in the ash pan prior to lighting.

1. Turn FEED ADJUSTER to desired feed rate. No. 4 is good for most pellets.
2. Turn the MODE SELECTOR to "OFF" and then to the desired mode. This will reset control and start the combustion motor.
3. Turn the TEMPERATURE DIAL to the desired setting.
4. Clean burn pot with scraper if necessary.
5. Fill burn pot with pellets, only level with front edge. (Do Not Over Fill).
6. Add starting gel on top of the pellets. Stir gel into pellets for fast lighting.
7. Light starting gel with a match, and close the door. Operation will begin when the fire reaches the proper temperature.
8. Fill hopper with pellets and remove ashes as required.

Store fuel in a dry area, away from all ignition sources and outside all limits of the stove's clearance requirements to combustibles. Do not store the fuel where it interferes with the refueling of the stove or emptying of ashes. Do not store any ashes removed from the stove near the fuel or other combustible materials.



WARNING

BURNING GARBAGE, USE OF IMPROPER FUELS, FIRE STARTERS OR ALTERING THE STOVE FOR HIGHER HEAT OUTPUT MAY CAUSE DAMAGE TO THE STOVE AND COULD RESULT IN A HOUSE FIRE. USE ONLY APPROVED FUELS AND FOLLOW ONLY THESE OPERATION GUIDELINES.



WARNING

NEVER USE GASOLINE, GASOLINE-TYPE LANTERN FUEL, KEROSENE, CHARCOAL LIGHTER FLUID, OR SIMILAR LIQUIDS TO START OR 'FRESHEN UP' A FIRE IN THIS HEATER. KEEP ALL SUCH LIQUIDS WELL AWAY FROM THE HEATER WHILE IN USE.

F. Manual Ignition (Continued)

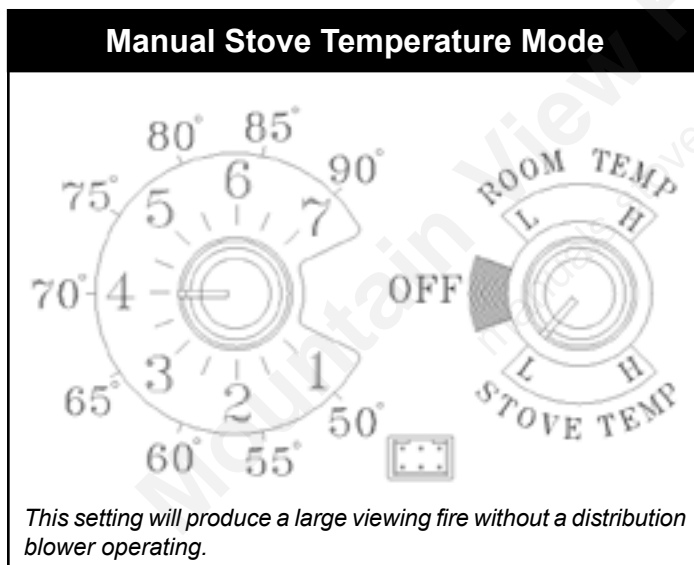
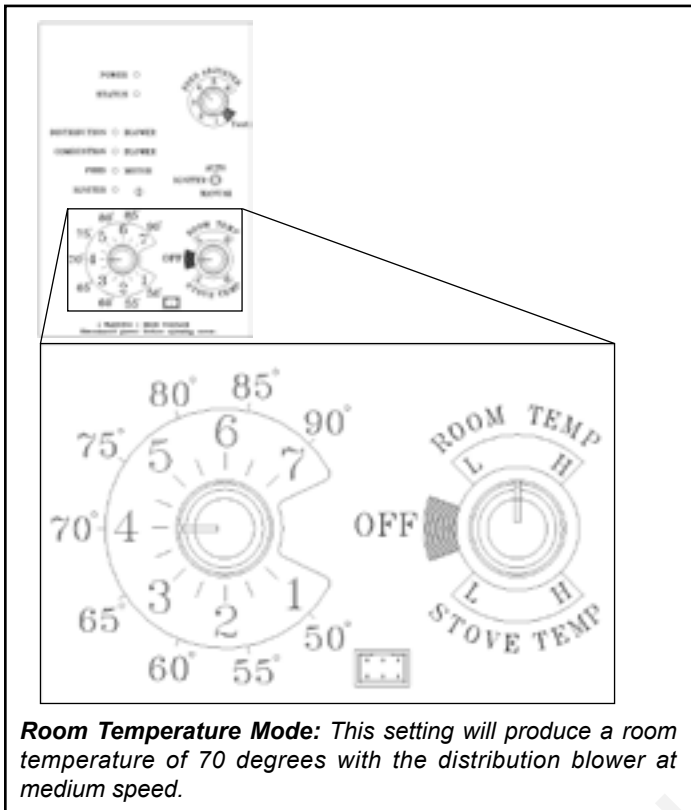

The Accentra 52i Pellet Insert is capable of manual operation. This also allows the operator to manually control operation during an emergency (i.e. igniter failure, when using a 512H battery backup, or when using certain generators.)

The unit can be switched between "AUTO" and "MANUAL" at any time during operation.

NOTE: When starting the unit in the "AUTO" mode and switching to "MANUAL", you may switch at any time. Once an ignition cycle is started, it will continue regardless of mode.

Igniter Switch to "MANUAL"

Room Temperature Mode

The fire will have to be lit with starting gel and a match, or started automatically, see "Automatic Operation". Turn to "Manual" position once the start cycle begins.

The difference between "AUTO" Room Temperature Mode and "Manual" Room Temperature Mode is that the fire will not go out as the room temperature goes above the control board setting. The unit can only go to low burn and will remain there until it runs out of fuel or until more heat is needed and the feed rate increases. Feed rate adjustments and dial settings are the same as "AUTO" settings.

Igniter Switch to "MANUAL"

Stove Temperature Mode

The advantage of this mode is to allow the operator to have a large viewing fire without blowing extra heat into the room.

During operation, with the temperature dial set at #4 or less, the distribution fan will not operate. A #4 on the temperature dial and a #4 on the feed adjuster is approximately 80% output. It is not necessary to operate the distribution blower below this point. Therefore, there can be a higher feed rate (a larger viewing fire) without an excess of hot air blowing into the room.



An example of when to use the Manual Stove Temperature Mode is if you want to watch a large fire and the room is already up to temperature. The Stove Temperature Mode allows you to have a larger fire and a lower sound level, without the distribution blower.

NOTE: During the use of this mode, if you keep increasing the temperature dial setting to increase the fire size, the distribution blower will automatically come on when the ESP Temperature reaches 350° F, or 81% output.

5 Maintenance & Service

When properly maintained, your stove will give you many years of trouble-free service. **Contact your dealer** to answer questions regarding proper operation, trouble-shooting and service for your appliance. Visit www.harmanstoves.com to find a dealer. We recommend annual service by a qualified service technician.

A. Proper Shutdown Procedure

 CAUTION	
	Shock and Smoke Hazard
	• Turn unit to the off position, let appliance completely cool and combustion blower must be off. Now you can unplug appliance before servicing.
	• Smoke spillage into room can occur if appliance is not cool before unplugging.
	• Risk of shock if appliance not unplugged before servicing appliance.

Follow the detailed instructions found in this section for each step listed in the chart below.

B. Quick Reference Maintenance Chart

Cleaning or Inspection	Frequency		Daily	Weekly	Monthly	Yearly
Ash Pan	Every 10 bags of fuel depending on the fuel type or ash build-up	OR		X		
Ash Removal from Firebox	Every 5 bags or more frequently depending on the fuel type or ash build-up	OR		X		
Heat Exchanger	Every 1 ton of fuel	OR			X	
Blower, Combustion (Exhaust)	More frequently depending on the fuel type	OR				X
Blower, Distribution	Prior to heating season	OR				X
Door Gasket Inspection	Prior to heating season	OR				X
Exhaust Path	More frequently depending on ash build-up	OR				X
Firebox - Prepare for Non-Burn Season	At end of heating season	OR				X
Burnpot - Burning pellets - hardwood	Every 3 bags	OR	X			
Burnpot - Burning pellets - softwood	Every 5 bags	OR	X			
Glass	When clear view of burnpot becomes obscure	OR		X		
Hopper / Hopper Lid Gasket	Every 50 bags of fuel or when changing fuel types	OR			X	
Venting System	More frequently depending on the fuel type	OR				X

NOTICE: These are recommendations. Clean more frequently if you encounter heavy build-up of ash at the recommended interval or you see soot coming from the vent. **Not properly cleaning your appliance on a regular basis will void your warranty.**

C. General Maintenance

Types of Fuel

The type of fuel you are burning will dictate how often you have to clean your burnpot.

If the fuel you are burning has a high dirt or ash content or you are burning shelled field corn, it may be necessary to clean the burnpot more than once a day.

Dirty fuel will cause clinkers to form in the burnpot. A clinker is formed when dirt, ash or a non-burnable substance is heated to 2000° F (1093° C) and becomes glass-like.

Once a year the removal of the fireplace insert should be done for the purpose of inspecting the fireplace insert and fireplace.

Be sure to inspect and clean exhaust venting system regularly.

D. Glass Maintenance

The glass used in your stove is manufactured to exact standards to withstand the high heat of the fire, but like all glass, it must be treated with common sense and care. Never abuse the glass by slamming the door shut or striking the glass with a heavy object. If the glass is broken or damaged, do not operate the stove until it has been replaced.

Glass - Replacement

If the stove's glass is cracked or broken, you must replace it before operating your stove. Remove pieces carefully. Replace glass only with Harman® replacement glass; **do not use substitutes.**

Carefully remove damaged glass, gasket material, and hold down clips (set aside).

Install the self adhesive 1/4" gasket material around the front face of the glass. Set the glass panel and gasket gently onto the door. Install the hold down clips and tighten with bolts.

Glass - Cleaning

Sometimes it will be necessary to clean accumulated ash from the glass surface; allowing this ash to remain on the glass for long periods can result in "etching" due to the acidity of the ash. Never clean the glass while it is hot, and **do not** use abrasive substances. Wash the surface with cool water, and rinse thoroughly. You may wish to use a non-abrasive cleaner specifically designed for use on stove glass. In any case, dry thoroughly before relighting your stove.

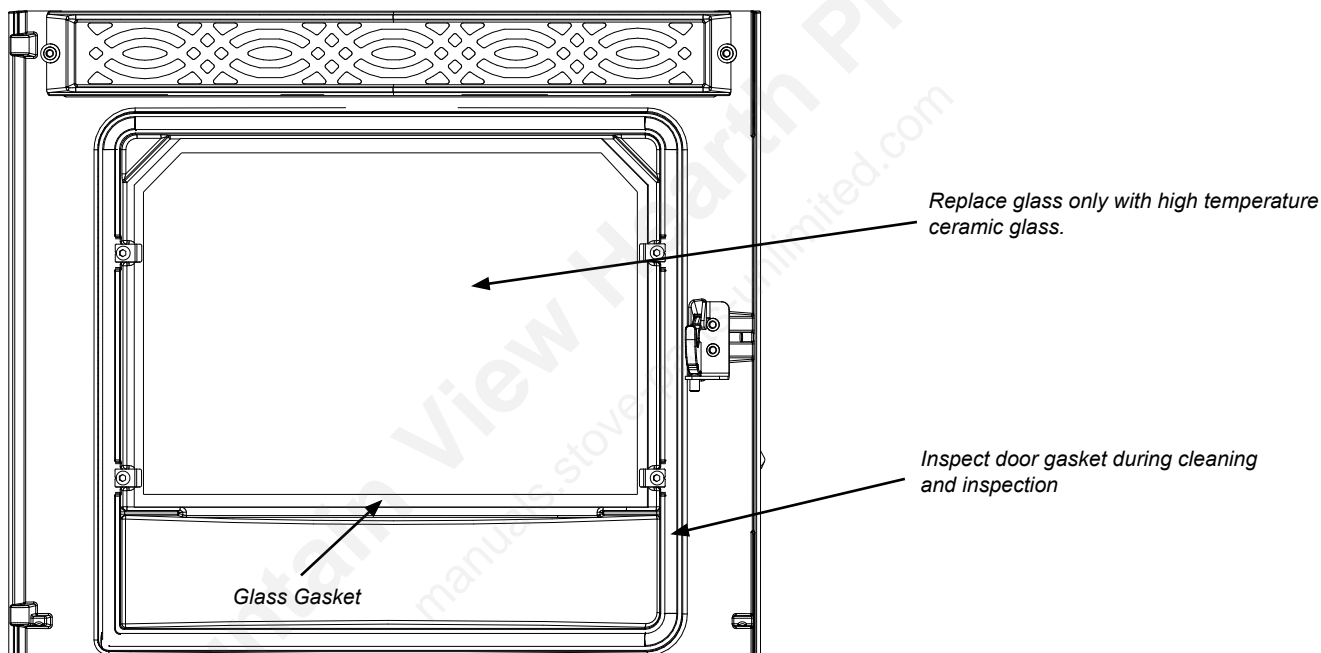

E. Burnpot Maintenance

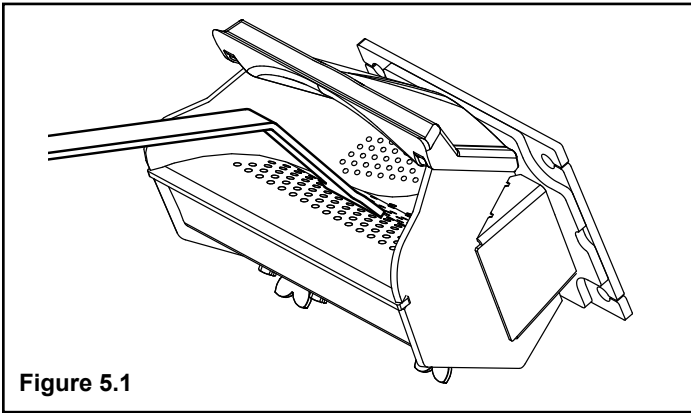

Figure 5.1

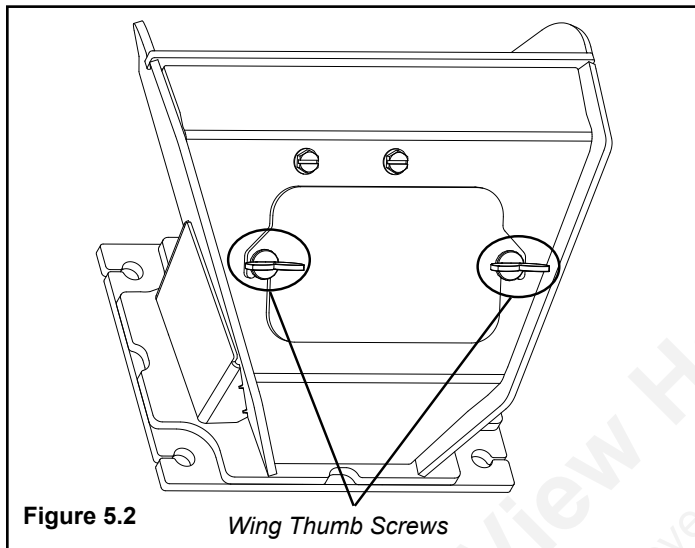

Figure 5.2
Wing Thumb Screws

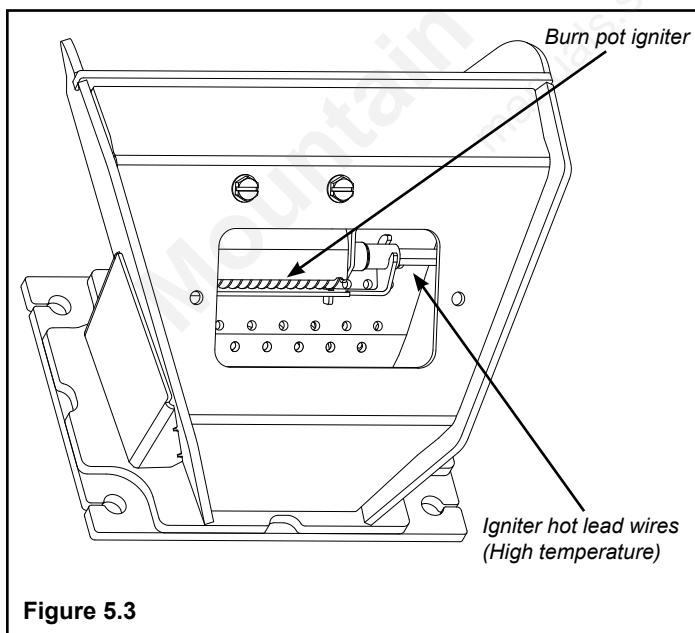

Figure 5.3

Viewed from below through the ash pan opening.

Whenever adding fuel, take the opportunity to clean the burn pot. **(Weekly at minimum)**

- Scrape the top holed surface and sides of the burn pot down to auger tube Figure 5.1. It is not necessary to completely remove all material from the burn pot. The excess will be pushed out during the next use.

Monthly, or after each ton of fuel burned:

- Loosen the (2) wing thumb screws on the lower front angle of the burn pot. Figure 5.2
- Lift off the clean-out cover to open the bottom clean-out chamber. Figure 5.3



DANGER

Disconnect the power to the unit before removing cover.

- Clean ash buildup from inside the chamber while cover is off. Use the scraper to tap on the top front edge of the burn pot. This will help knock pieces of ash, loosened by the scraping process, down through the holes. It also helps knock scale off of the igniter element.

Figure 5.3

The igniter is made to be removable for service by insulated male/female wire connectors. These connections between the hot leads (the wires inside the burn pot) and the cold leads (the wires from the control board) are always pulled to the inside rear of the feeder body. **(Not coiled inside the burn pot.)**

It is very important that these connections are to the inside rear of the feeder body. Also, the extra wire of the igniter wire service loop must be pulled out through the rear of the feeder and tied up so that it will not be damaged by any moving parts.



WARNING

Use caution when cleaning burn pot clean-out chamber. Do not damage the high temperature igniter wires.

Note: The hot lead/cold lead connection must always be pulled to the rear of the feeder body before operation.

F. Combustion Blower Chamber

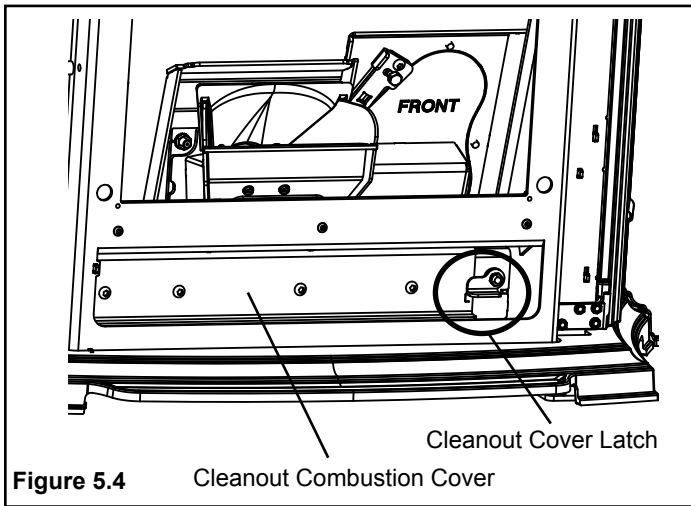

Monthly Cleaning- continued:

There is a cleanout cover latch located on the lower right hand side of the firebox that holds the Cleanout Combustion Cover in place Figure 5.4. In order to gain access to this area the medallion and cast rear covers must be removed. Once cast components are removed, pull up on cleanout cover latch to remove the cleanout combustion cover. This gives you access to the lower combustion chamber. Figure 5.5.

Once cleanout combustion cover is removed you can remove the combustion cover assembly Figure 5.5. To do this, pull up on the combustion cover latch Figure 5.6, and pull the combustion cover assembly toward you and out. **NOTE:** When re-installing the Combustion Cover Assembly make sure you insert the bottom of the cover first prior to putting it into place.

Once combustion cover assembly is removed you now have access to clean the combustion blower chamber area. Figure 5.7.

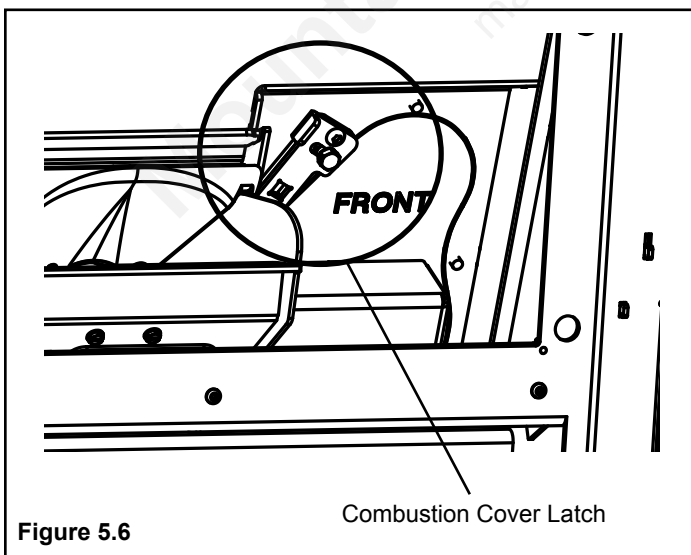
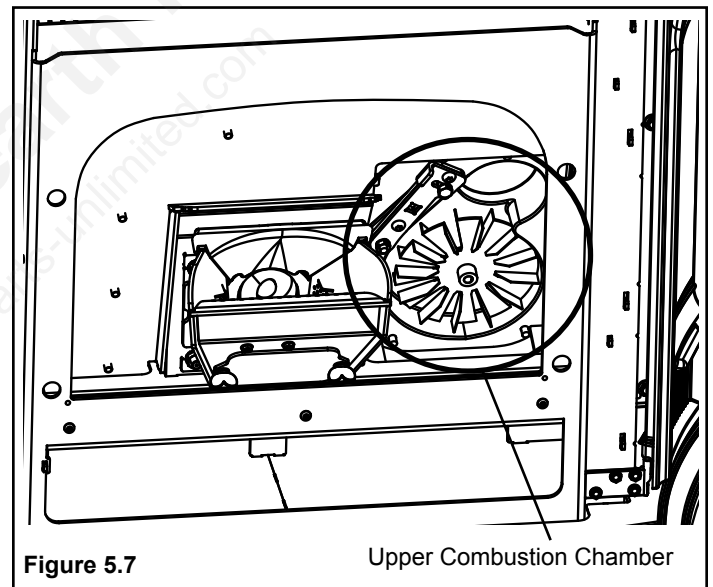
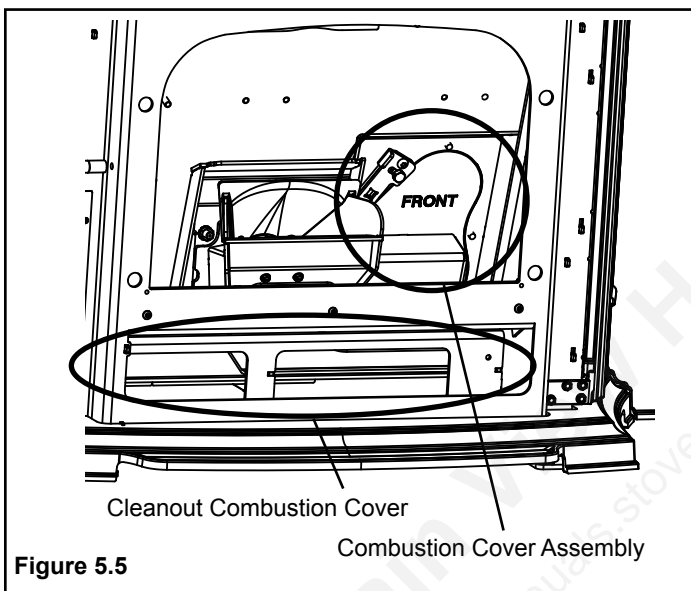

G. Pellet Feeder Chamber

Figure 5.8

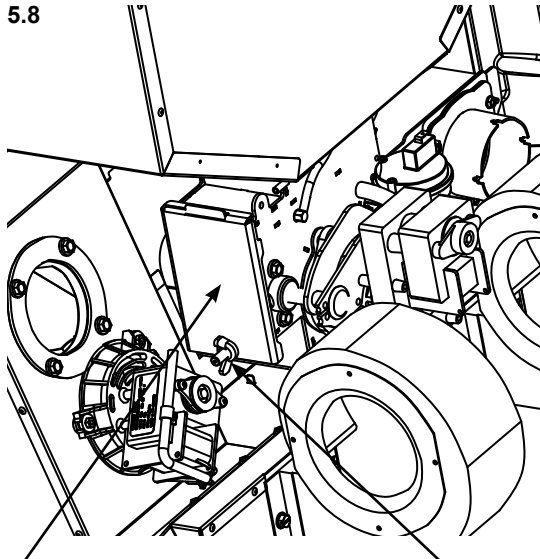

Feeder clean out cover

5/16" Wing Nut

Feeder Chamber

This chamber may get a buildup of fines from the feeder mechanism movement. This area should be checked and cleaned at least once a year.

To remove the feeder cover:

- Loosen the 5/16" wing nut Figure 5.8.
- Lift up and slide the cover off of the threaded stud.
- Inspect and clean the inner chamber if necessary. Figure 5.9.
- Reinstall the cover making certain it is seated properly on the feeder body and tighten as tightly as you can by hand.

NOTE: Views are shown with the exhaust tube and covers removed for better viewing.

Figure 5.9

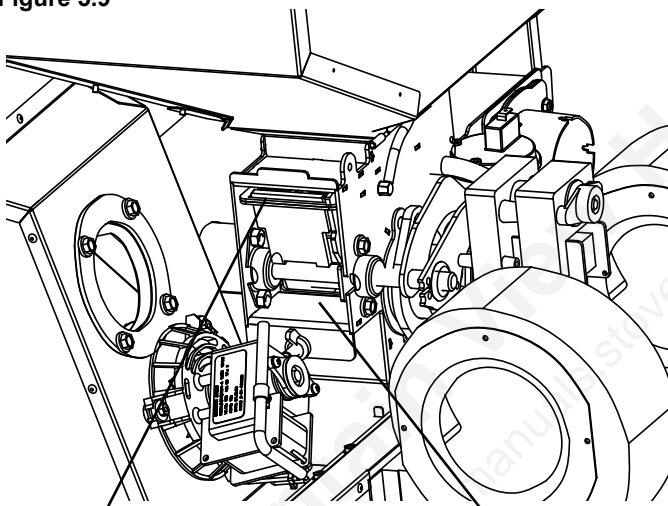

Pellet Metering
Slide Plate

Possible pellet fines
buildup area.

6 Troubleshooting and Frequently Asked Questions

A. Error Code Description

Status light error messages:

3 Blinks: Indicates that the ESP (Exhaust Sensing Probe) has failed, has a broken connection, or has gone out of range too many times. This requires a manual reset*.

4 Blinks: Can occur only in Room Temp Mode and indicates Room Sensing Probe failed or not installed. If a Room Sensing Probe is then installed, the status light will automatically reset.

NOTE: Unit will not start in "AUTO" with this status error.

5 Blinks (In Igniter Auto. Mode Only): Indicates that the unit has failed to light within the 36 minute start cycle. To reset - Turn Mode Selector to "OFF", then turn to either mode again.)

6 Blinks : Indicates that the control has calculated poor or incomplete combustion occurring for more than 25 minutes.

A six blink status may occur if the stove is allowed to run out of pellets. To reset, turn mode selector to "OFF" then back on to the desired mode.

* **Manual reset** - disconnect power cord for a few seconds and reconnect. If error still occurs call your Dealer.

B. Frequently Asked Questions

ISSUES	SOLUTIONS
1. Metallic noise.	1. Noise is caused by metal expanding and contracting as it heats up and cools down, similar to the sound produced by a furnace or heating duct. This noise does not affect the operation or longevity of your appliance.
2. White ash buildup on glass.	2. This is normal. Clean the glass using any non-abrasive glass cleaner.
3. Glass has buildup of black soot	3. Excessive build-up of ash. See solution #4. The lower burn settings will produce more ash, the higher burn settings produce less. The more it burns on low the more frequent cleaning of the glass is required.
4. Glass has turned dirty.	4. Excessive build up of ash. The lower burn settings will produce more ash, the higher burn settings produce less. The more it burns on low the more frequent cleaning of the glass is required.
5. Fire has tall flames with black tails and is lazy.	5. The feed rate needs to be reduced or the burnpot needs cleaning. Heat exchanger or exhaust blower needs cleaning.
6. Smokey start-up or puffs of smoke from the airwash.	6. Either the burnpot is dirty or there is too much fuel at start-up and not enough air.
7. Large flame at start-up.	7. This is normal. Flame will settle down once the fire is established.

Contact your dealer for additional information regarding operation and troubleshooting. Visit www.harmanstoves.com to find a dealer.

C. Troubleshooting

With proper installation, operation, and maintenance your appliance will provide years of trouble-free service. If you do experience a problem, this troubleshooting guide will assist a qualified service person in the diagnosis of a problem and the corrective action to be taken. This troubleshooting guide can only be used by a qualified service technician.

STOVE DOES NOT FEED

1. No fuel in hopper.
2. Firebox draft may be too low for sensing switch in feeder circuit to operate. **Check for closed doors**, loose or missing gasket on doors or hopper lid.
3. Feed motor will not run until the ESP control senses a certain temperature. Maybe you did not put enough fuel or starting gel in the burn pot before manually lighting the fire.
4. Restriction in the hopper or feeder. Remove all fuel and examine. Clear the obstruction.
5. Feed motor has failed.

PARTIALLY BURNED PELLETS

1. Feed rate too high.
2. Poor air to fuel mixture. (Check burn pot clean-out cover and air intake).
3. Burn pot or heat exchanger may need to be cleaned.
4. Combination of all the above.
5. #6 status blink: A 6 blink control board status indication is caused by poor or incomplete combustion. The circuit board has the ability to track the combustion through feed settings and ESP temperatures. When the control board has calculated poor or incomplete combustion, it will shut down the unit as a safety feature. (Poor or incomplete combustion is a contributor of creosote which may cause a chimney fire)

A 6 blink status may be caused by several things:

1. Blocked or partially blocked flue.
2. Blocked or partially blocked inlet air.
 - a. Backdraft damper on the inlet pipe may be stuck closed.
 - b. If outside air is installed, the inlet cover may be blocked.
3. The air chamber under the burnpot may be filled with fines and small bits of ash.
4. The holes in the burnpot may be getting filled with ash or carbon buildup.
5. Combustion blower fan blades may need cleaned.
6. Fuel restrictions as noted above.

SMOKE SMELL

Seal the vent pipe joints and connection to stove with silicone. The exhaust vent is the only part of the system that is under positive pressure.

FIRE HAS GONE OUT- Check for status light.

1. No fuel in hopper.
2. Draft is too low, blocked flue.
3. Something is restricting fuel flow.
4. Feed motor or combustion blower has failed.

SMOKE IS VISIBLE COMING OUT OF VENT

1. Air-fuel ratio is too rich.
 - a. Feed rate too high.
 - b. Draft too low caused by a gasket leak.

LOW HEAT OUTPUT

1. Feed rate too low
2. Draft too low because of gasket leak.
3. Poor quality or damp pellets
4. Combination of 1 and 2.

HELPFUL HINTS

Cleaning Burn Pot

Whenever your stove is not burning, take the opportunity to scrape the burn pot to remove carbon buildup. A vacuum cleaner is handy to remove the residue. Be sure the stove is cold if you use a vacuum.

Carbon buildup can be scraped loose with the fire burning using the special tool provided with your stove. Scrape the floor and sides of the burn pot. The carbon will be pushed out by the incoming fuel. Always wear gloves to do this.

Removing Ashes

Turn the Temp Dial to number 1 approximately 30 minutes before removing ashes. This will result in a cooler stove and ash pan.

Maximum Feed Adjuster settings are not needed in most cases. Operating in the normal range (#4) is recommended when maximum heat output is not required. The ESP probe prevents the stove from being over-fired.

Keep the stove free of dust and dirt.

Fuel

This Pellet Insert is approved for burning any grade of wood pellet fuel. It is also approved for burning shelled corn in a mixture with wood pellets, up to 50%.

It should be noted, however, that higher ash content will require more frequent ash removal, scraping of the burn pot, and may provide less BTU's per pound.

The moisture content of pellets must not exceed 8%, and corn must not exceed 15%. Higher moisture will rob BTU's and may not burn properly.

Fuel should **not** be stored within the stove installation clearances or within the space required for charging and ash removal.

7 Reference Material

A. Safety Reminders

When operating your Harman® Pellet Stove, respect basic safety standards. Read these instructions carefully before you attempt to operate the Pellet Stove. Failure to do so may result in damage to property or personal injury and may void the product warranty.

CAUTION: This appliance must be vented to the outside.

Due to high temperatures, this stove should be placed out of traffic and away from furniture and draperies.

Children and adults should be alerted to the hazards of high surface temperatures and should stay away to avoid burn to skin and/or clothing.

Young children should be carefully supervised when they are in the same room as the stove.

Clothing and other flammable materials should not be placed on or near this stove.

Installation and repair of this stove should be done by a qualified service person. The appliance should be inspected before use and at least annually by a qualified service person. More frequent cleaning will be required. It is imperative that control compartments, burners, and circulating air passageways of this stove be kept clean.

Disposal of ashes: Ashes should be placed in a metal container with a tight fitting lid. The closed container of ashes should be placed on a non-combustible floor or on the ground, well away from all combustible materials, pending final disposal. If the ashes are disposed of by burial in soil or otherwise locally dispersed, they should be retained in the closed container until all cinders have thoroughly cooled.

Soot and fly ash: Formation and need for removal. The products of combustion contain small particles of fly ash. The fly ash will collect in the exhaust venting system and will restrict the flow of the flue gases. Pellet fuels have different ash contents depending on what type of wood has been used to make the pellets. **We recommend cleaning the system after approximately 1 ton of pellets have been burned and judge from that how often the stove should be cleaned, remember if you change pellets it may change how often you have to clean your stove.**

When burning wood slowly, the potential exists for creosote to form. The venting system should be inspected periodically throughout the heating season to determine if a creosote buildup has occurred. If a significant layer of creosote has accumulated (3mm or more), it should be removed to reduce the risk of a chimney fire. If a fire occurs, call the fire department, shut down the stove, and evacuate the residence. Before using the appliance, have the venting system thoroughly inspected and replace any damaged components.

WARNING

MOBILE/MANUFACTURED HOME GUIDELINES DO NOT ALLOW INSTALLATION IN A SLEEPING ROOM.

CAUTION

THE STRUCTURAL INTEGRITY OF THE MOBILE HOME FLOOR, WALL, AND CEILING/ROOF MUST BE MAINTAINED.

CAUTION

THE STOVE IS HOT WHILE IN OPERATION. KEEP CHILDREN, CLOTHING AND FURNITURE AWAY. CONTACT MAY CAUSE SKIN BURNS.

WARNING

KEEP COMBUSTIBLE MATERIALS SUCH AS GRASS, LEAVES, ETC. AT LEAST 3 FEET AWAY FROM THE POINT DIRECTLY UNDER THE VENT TERMINATION.

WARNING

USE OF IMPROPER FUELS, FIRE STARTERS OR ALTERING THE STOVE FOR HIGHER HEAT OUTPUT MAY CAUSE DAMAGE TO THE STOVE AND COULD RESULT IN A HOUSE FIRE. USE ONLY APPROVED FUELS AND OPERATION GUIDELINES

B. Motor and Component Location

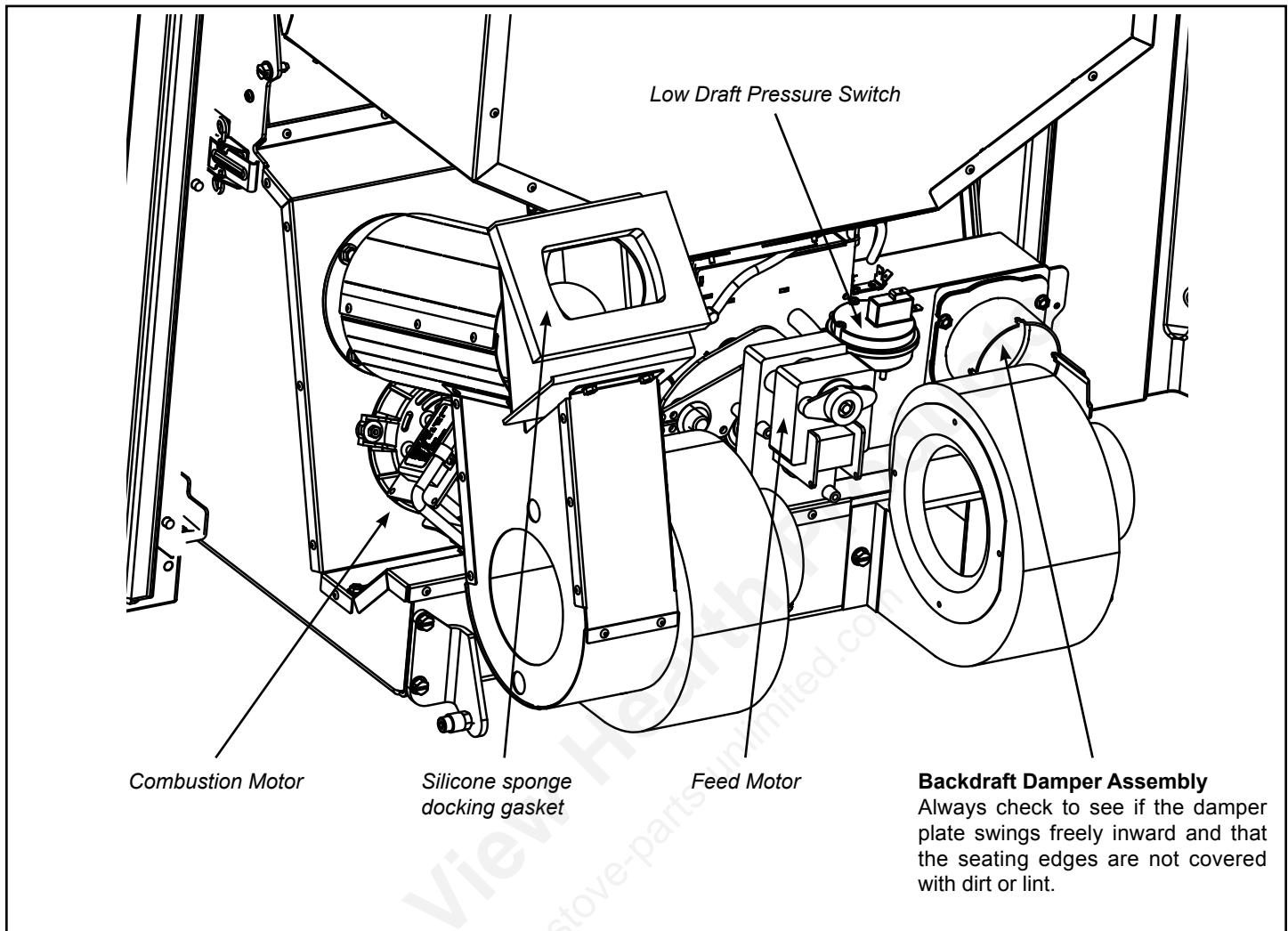

Accentra 52i Pellet Insert Safety Devices

The **Control Board/ESP** combination is responsible for all high limit safety control. There are 2 high limits, one normal operation high limit and one backup high limit. The control has an automatic diagnostic circuit that continuously monitors the ESP and Room Sensor for faults. If a fault should occur, the control sends a status alert and at the same time the unit goes down to minimum feed/minimum burn as a safety condition.

The **Low Draft Pressure Switch** is a differential pressure switch that monitors the negative pressure (Draft) in the firebox. If the draft becomes too low for proper combustion, the switch opens, cutting power to the feed motor and the igniter circuits. This switch is connected into the AC (high voltage) wiring.

In the event of component failure, replace component(s) equivalent to the original. See Service Parts section of this manual.

C. Loss of Power

Minimizing Smoke During Loss of Power Using Battery Back-up

Harman® strongly recommends installing battery back-up to minimize entry of smoke into the room in the event of power loss.

Your pellet/biomass burning appliance relies on a combustion blower to remove exhaust. A power failure will cause the combustion blower to stop. This may lead to exhaust seeping into the room. Vertical rise in the venting may provide natural draft. It is, however, no guarantee against leakage.

There are two Harman® approved battery back-up options for your appliance:

Uninterruptible Power Supply (UPS) UPS battery back-ups are available online or at computer and office equipment stores. Your Harman® appliance with Rev E or later software available beginning in November 2010 may be plugged directly into a Harman® approved UPS:

- The APC (American Power Conversion) model #BE750G and the TrippLite model INTERNET750U are tested and approved. Other brands or models may not be compatible.

When power is lost, a fully charged UPS will power a safe, combustion blower only shut-down. Your appliance will pulse the blower every few seconds to clear exhaust until the fire is out. **NOTE: The UPS provides safe shut-down only. It is not intended for continued operation.**

Your appliance will recognize when power is restored. What happens depends on ESP temperature and whether it is equipped with automatic ignition:

- In **“Automatic” setting**, units equipped with automatic ignition will respond to the set point and ESP temperature and resume normal operation.
- In **“Manual” setting** or for units without automatic ignition:
 - If the ESP is cool, the appliance will remain shut down.
 - If the fire is out and the ESP is still warm, the feeder may restart. Since the fire is out, the ESP temperature will not rise. The unit will then shut-down, and may flash a six-blink status error. (See ESP error codes)
 - If the fire is still burning, it will resume normal operation.

Contact your dealer if you have questions about UPS compatibility with your appliance.

Harman® Surefire 512H Battery Back-up The 512H connects to a 12 volt deep cycle battery that will run your appliance for up to eight (8) hours. It includes a trickle charge feature that keeps your battery charged when power is available. **NOTE: If the power is out for longer than battery life, smoke leakage may still occur unless your stove has been safely shut down.**

CAUTION! Always keep appliance doors and hopper lid closed and latched during operation and during power failures to minimize risk of smoke or burn-back.

CAUTION! Use only Harman® approved battery back-up devices. Other products may not operate properly, can create unsafe conditions or damage your appliance.

D. Service Parts



Service Parts

ACC52i

Pellet Insert

Beginning Manufacturing Date: July 2013
Ending Manufacturing Date: Active

20" Hopper:
1-90-574200-1 (Black)
1-90-574200-14 (Majolica Brown)

22" Hopper:
1-90-574220-1 (Black)
1-90-574220-14 (Majolica Brown)

24" Hopper:
1-90-574240-1 (Black)
1-90-574240-14 (Majolica Brown)

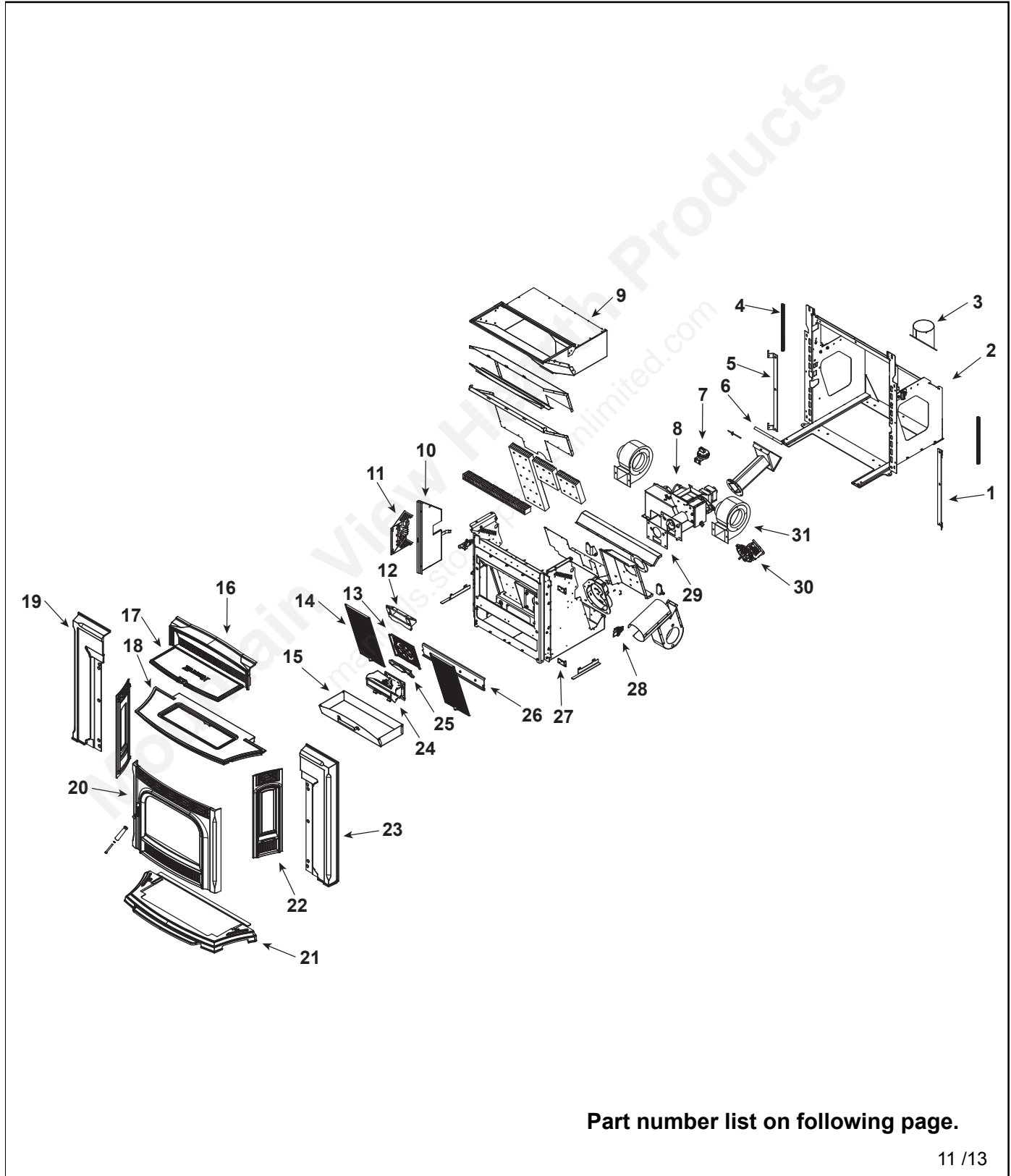

Part number list on following page.

IMPORTANT: THIS IS DATED INFORMATION. Parts must be ordered from a dealer or distributor. **Hearth and Home Technologies does not sell directly to consumers.** Provide model number and serial number when requesting service parts from your dealer or distributor.



Stocked at Depot

ITEM	Description	COMMENTS	PART NUMBER	
1	Cast Side Hinge	Right & Left	1-00-574075	
2	Mounting Frame Assembly		1-10-574077A	
	Roller hardware	4 sets	1-00-02243	Y
3	Pipe Stub for 4 in. Flex/PL w/gasket		1-00-574034	Y
	Pipe Stub Plate Gasket	Pkg of 5	3-44-574045	Y
4	All Thread .500-13 x 12, Frame Jacking	Qty 2 req	3-31-00949	
5	Cast Side Hinge	Right & Left	1-00-574075	
6	Docking Gasket Red Silicone		3-44-06108	Y
7	Differential Switch		3-20-6866	Y
	Silicone Tubing, 1/8"	5 Ft	1-00-5113574	Y
8	Feeder Assembly		Refer to page 4	
9	Hopper Assembly - Height 20"		1-10-574334A	Y
	Hopper Assembly - Height 22"		1-10-574339A	Y
	Hopper Assembly - Height 24"		1-10-574038A	Y
	Gasket, Hopper Top	20 ft	1-00-375501	Y
	Gasket, Hopper Throat		3-44-677185	Y
10	Control Heat Shield		2-00-574082B	
11	Control Board Mounting Plate		1-10-574121	
	Circuit Board w/Knobs & Shafts		1-00-05886	Y
	D-Shape Knob/ Shaft	25 Sets	1-00-015605	Y
	Control Board Label		3-90-06655A	
	Fuse 6 AMP	Pkg of 5	3-20-49447-5	Y
12	Medallion Holder		1-10-574098W	
13	Cast Center Medallion		3-00-674060	Y
14	Cast Heat Exchanger CVR	Qty 2 req	3-00-674050	Y
15	Ash Pan		1-10-574007A	Y
16	Cast Wing Center	Black Paint	4-00-574323P	Y
		Majolica Brown	1-10-574323-14	Y
17	Cast Hopper Lid	Black Paint	4-00-574320P	
		Majolica Brown	1-10-574320-14	
	Label, Large Caution		3-90-00247	
18	Cast Top	Black Paint	4-00-574319P	
		Majolica Brown	1-10-574319-14	
19	Cast Wing Left	Black Paint	4-00-574321P	Y
		Majolica Brown	1-10-574321-14	Y

Additional service parts on following page.

IMPORTANT: THIS IS DATED INFORMATION. Parts must be ordered from a dealer or distributor. **Hearth and Home Technologies does not sell directly to consumers.** Provide model number and serial number when requesting service parts from your dealer or distributor.



Stocked at Depot

ITEM	Description	COMMENTS	PART NUMBER	
20	Door Assembly	Black Paint	4-00-674053A	Y
		Majolica Brown	4-00-674053-14A	Y
	Door Latch		3-00-249119P	Y
	Glass		3-40-677000	Y
	Glass Clip	Pkg of 4	1-00-249140	Y
	Rope 3/16" Gasket w/PSA (Glass)	10 Ft	1-00-1186258229	Y
	Rope 3/8" Gasket (Door)	30 Ft	1-00-00888	Y
	Trim Plate		2-00-674206P	
	Wood Handle & Bolt	Pkg of 2	1-00-00247	Y
	Latch Roller hardware		1-00-05230	Y
21	Cast Bottom Ashlip	Black Paint	3-00-574318P	
		Majolica Brown	1-10-574318-14	
	Magnetic Latch Assembly w/3/16" Hole	2 Sets	1-00-08288	
22	Cast Side Panel, Qty 2 req	Black Paint	4-00-674054P	
		Majolica Brown	1-10-574054-14	
23	Cast Wing Right	Black Paint	4-00-574322P	Y
		Majolica Brown	1-10-574322-14	Y
24	Burn Pot Weldment		1-10-574128A	Y
			3-20-677200	Y
	Igniter Element	Pkg of 10	1-00-677200	Y
	Igniter Cradle, Holder, Flat bottom	3 Sets	1-00-06620	Y
	Superwool Gasket	Qty 2 req	3-44-724114	Y
	Cleanout Cover	2 sets	1-00-06623	Y
	Thumb Screw	Pkg of 10	3-31-782108-10	Y
25	Flame Guide		3-00-03000	Y
26	Cleanout cover		1-00-574086	
	Cleanout cover latch asy		1-00-574080	
	Cleanout cover gasket	3.5 ft	1-00-10025	Y
27	Hinge Plate	Qty 2 req	3-00-674047	
28	Spring Latches with hardware	Set of 2	1-00-00927	Y
29	Burn Pot Gasket	Pkg of 5	1-00-07381	Y
30	Combustion Blower		3-21-08639	Y
	Motor Blade, 5" Double Paddle		3-20-502221	Y
	Blower Mounting Screws	Pkg of 100	1-00-53483208	
31	Distribution Blower	Qty 2 req	3-21-33647	Y

Additional service parts on following page.

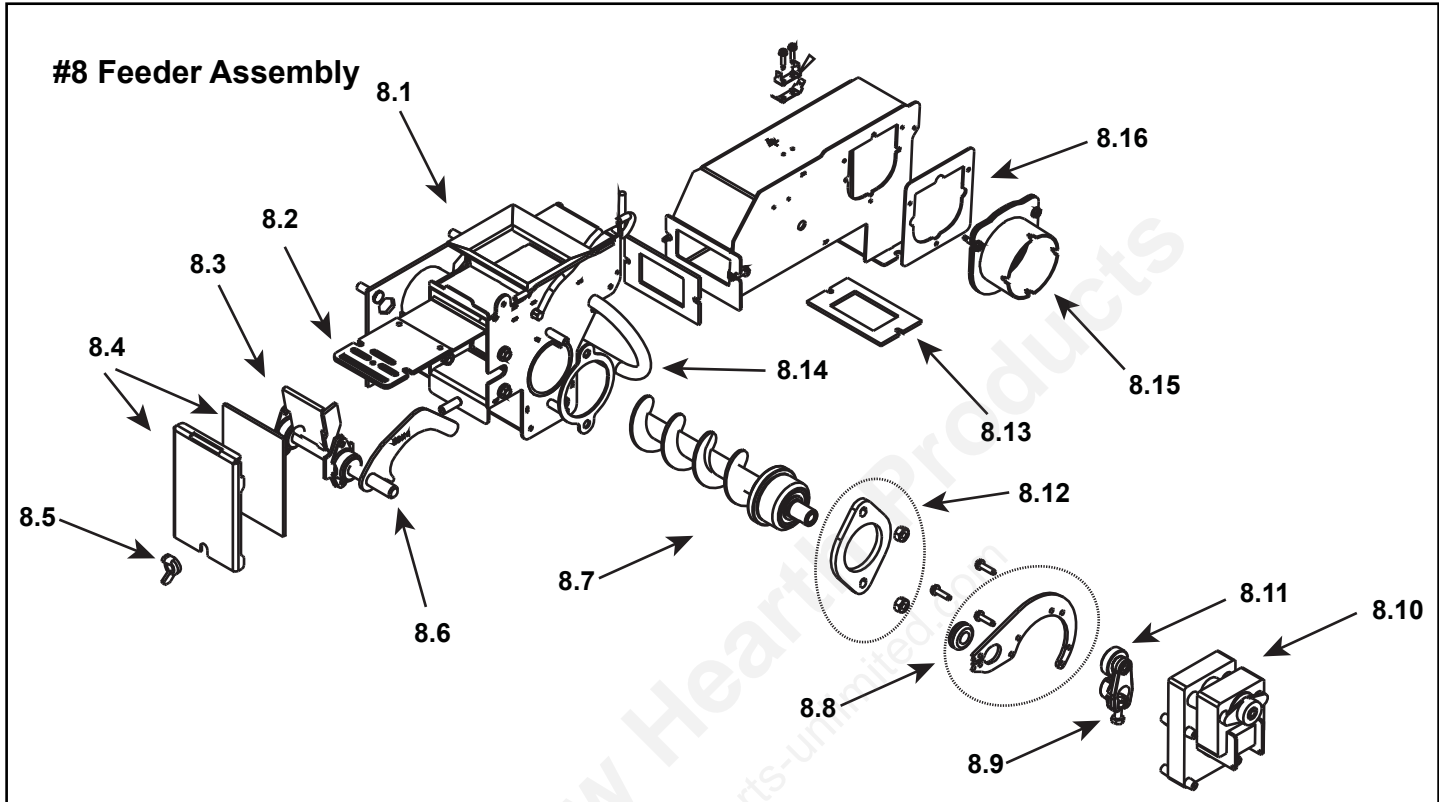

IMPORTANT: THIS IS DATED INFORMATION. Parts must be ordered from a dealer or distributor. **Hearth and Home Technologies does not sell directly to consumers.** Provide model number and serial number when requesting service parts from your dealer or distributor.



Stocked
at Depot

ITEM	Description	COMMENTS	PART NUMBER	
8	Feeder Assembly		1-10-574055A	
8.1	Ultra Feeder Weldment		1-10-724132	Y
8.2	Slide Plate Assembly		1-10-677121A	Y
8.3	Pusher Arm Pillow Block	Pkg of 4	3-31-3614087-4	Y
8.4	Gasket, UL Feeder Cover		1-00-677122	Y
8.5	5/16-18 wing screw	Pkg of 25	3-30-8012-25	
8.6	UL Feeder Pusher Arm		1-10-677187W	Y
8.7	UL Feeder Auger Assembly		3-50-00565	Y
8.8	UL Feeder Gear Motor Bracket w/Grommet		1-00-247406	Y
8.9	UL Feeder Cam Block		3-00-677154	Y
8.10	Pellet Feeder Gear Motor, 4 RPM		3-20-60906	Y
8.11	UL Feeder Cam Bearing		3-31-3014	Y
8.12	Bearing Flange w/Hardware		1-00-04035	Y
8.13	Gasket Ultra Air Intake	Pkg of 10	3-44-677160-10	Y
8.14	Feeder Air Crossover Kit		1-00-67900	Y
	9MM Silicone Tube	5 Ft	1-00-511427	Y
8.15	Pellet Air Intake Assembly		1-10-06810A	
8.16	Gasket Feeder Air Intake	Pkg of 6	3-44-72224-6	Y

Mountain View Hearth Products
manuals.stove-parts-unlimited.com

