

# Installation & Operating Manual

# HARMAN™

BUILT TO A STANDARD, NOT A PRICE

## The HydroFlex 60 Pellet Boiler

**DANGER: RISK OF FIRE OR EXPLOSION - DO NOT BURN GARBAGE, GASOLINE, DRAIN OIL OR OTHER FLAMMABLE LIQUIDS IN THIS APPLIANCE.**

**WARNING: RISK OF FIRE**

**- DO NOT OPERATE WITH FUEL LOADING OR ASH REMOVAL DOORS OPEN.**

**- DO NOT STORE FUEL OR OTHER COMBUSTIBLE MATERIAL WITHIN MARKED INSTALLATION CLEARANCES.**

**- INSPECT AND CLEAN ENTIRE VENTING SYSTEM INCLUDING ALL FLUES AND CHIMNEY REGULARLY.**

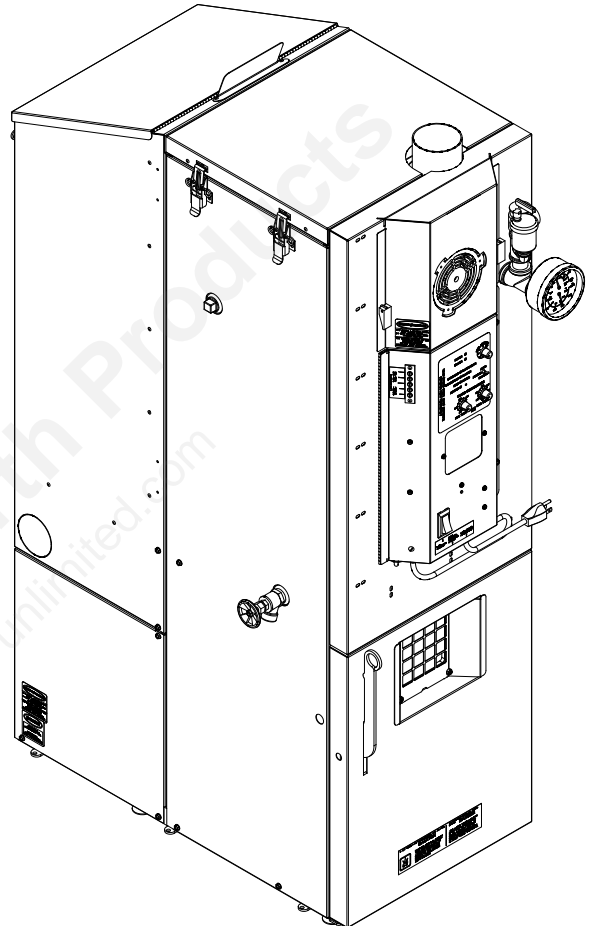

We suggest that our hearth products be installed and serviced by professionals who are certified in the U.S. by the National Fireplace Institute (NFI) as NFI Specialists.

Tested & Listed By



Portland Oregon, USA

OMNI-Test Laboratories, Inc

R14

## SAFETY NOTICE

**PLEASE READ THIS ENTIRE MANUAL BEFORE YOU INSTALL AND USE YOUR NEW BOILER. FAILURE TO FOLLOW INSTRUCTIONS MAY RESULT IN PROPERTY DAMAGE, BODILY INJURY, OR EVEN DEATH.**

**FOR RESIDENTIAL USE IN THE U.S. AND CANADA.**

**IF THIS PELLET BOILER IS NOT PROPERLY INSTALLED, A HOUSE FIRE MAY RESULT. FOR YOUR SAFETY, FOLLOW INSTALLATION DIRECTIONS.**

**CONTACT LOCAL BUILDING OR FIRE OFFICIALS ABOUT RESTRICTIONS AND INSTALLATION INSPECTION REQUIREMENTS IN YOUR AREA.**

**CONTACT YOUR LOCAL AUTHORITY (SUCH AS MUNICIPAL BUILDING DEPARTMENT, FIRE DEPARTMENT, FIRE PREVENTION BUREAU, ETC.) TO DETERMINE THE NEED FOR A PERMIT.**

**CETTE GUIDE D'UTILISATION EST DISPONIBLE EN FRANCAIS. CHEZ VOTRE CONCESSIONNAIRE DE HARMAN**

## SAVE THESE INSTRUCTIONS

3-90-232000

Mountain View Hearth Products  
manuals.stove-parts-unlimited.com

# HF60 Parts

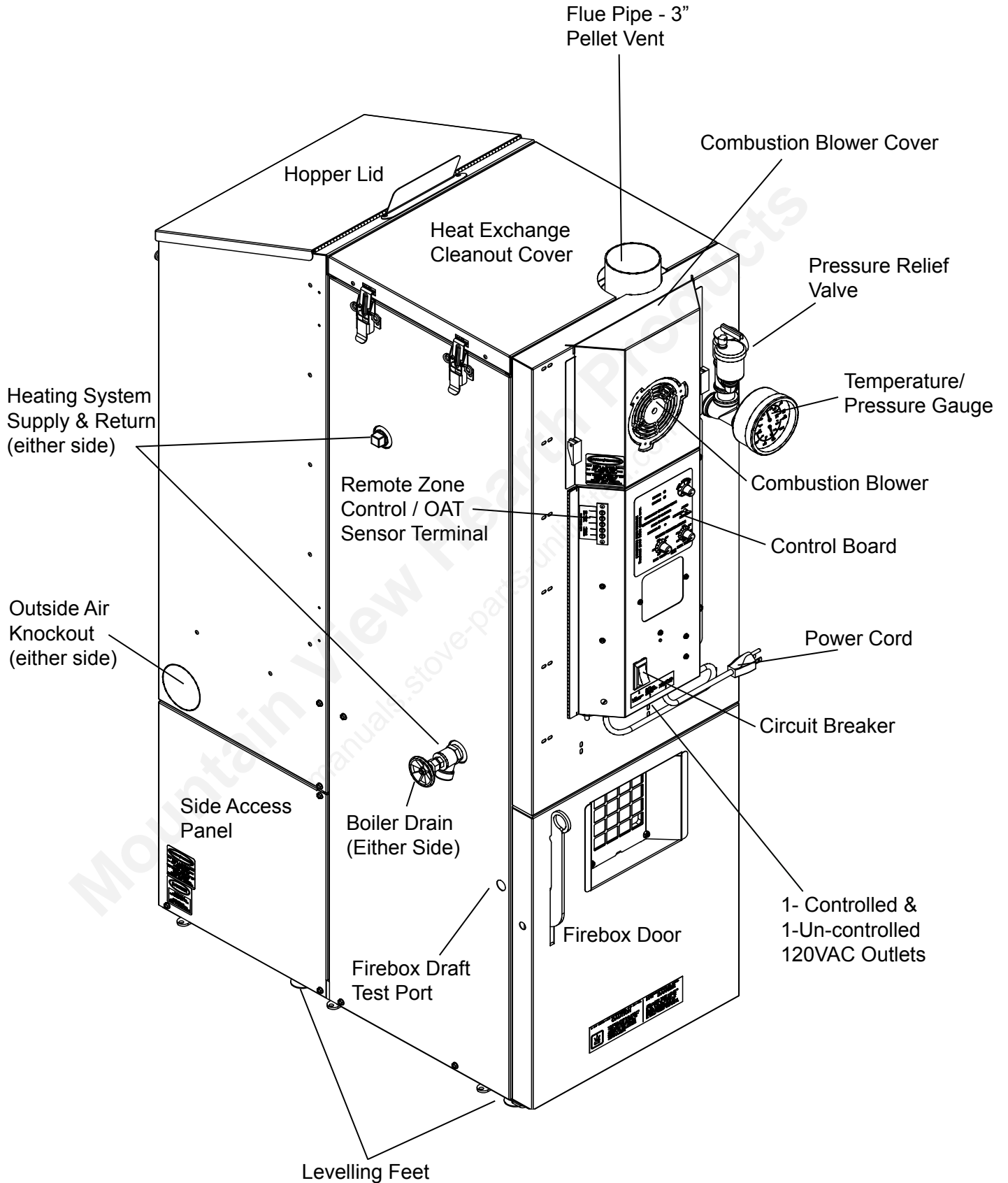

# Table of Contents

<b>Options</b>	<b>5</b>
<b>Installation</b>	<b>6</b>
<b>Venting</b>	<b>9</b>
<b>Plumbing</b>	<b>14</b>
<b>Electrical</b>	<b>20</b>
<b>Operation</b>	<b>26</b>
<b>Maintenance</b>	<b>33</b>
<b>Troubleshooting</b>	<b>38</b>
<b>Specifications</b>	<b>39</b>
<b>Wiring Diagram</b>	<b>40</b>
<b>Warranty</b>	<b>41</b>
<b>Testing Label</b>	<b>42</b>
<b>Service Parts</b>	<b>43</b>
<b>Start-Up Quick Reference</b>	<b>Back Cover</b>

Please read this entire manual before you install and use your new boiler. Failure to follow instructions may result in property damage, bodily injury, or even death.

## **SAVE THESE INSTRUCTIONS**

### **Hearth & Home Technologies**

352 Mountain House Road  
Halifax, PA 17032

# Options

## Outside Air Components

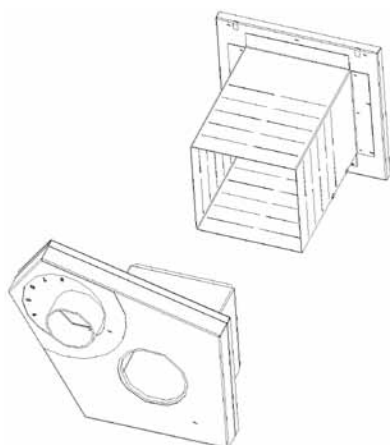

**Direct Vent Wall Passthrough**  
Item # 1-10-677077 provides for safe passing of the 3" pellet vent pipe through an outside wall, while providing the attachment for outside air. No extra holes needed.

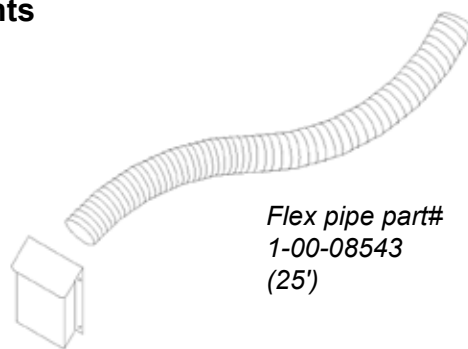

*Flex pipe part#  
1-00-08543  
(25')*

*Inlet Cover part#  
1-10-08542*

Standard method of attaching outside air. Be sure to use the inlet cover to prevent birds and/or rodents from entering the intake pipe. This method requires a hole to the outside, separate from the vent passage.

## Water Piping Supports-

Item # 2-00-232044B, secures to the boiler and gives the support needed for the expansion tank and circulator, while keeping them at a workable distance from the boiler.



## Bulk Storage Hopper-

Item #1-00-73450, with 1500 lb pellet capacity, it will automatically re-fill the unit hopper when it falls below a certain level.



## Atmospheric Conversion-

Item # 1-00-232200, provides automatic fill, and converts the heating system plumbing from pressurized to a zero pressure system. Allows for installation into more places where codes and standards restrict pressurized systems.



# Installation

## Boiler Kit Materials: (Refer to page 3)

List of items shipped with the unit.

- 1 - 3/4" Boiler Drain
- 1 - 3/4" Safety Relief Valve
- 1 - 1/2" Dual Temperature/Pressure Gauge
- 1 - Outdoor Air Sensor
- 2 - Piping Support Brackets
- 1 - Scraper Tool
- 4 - 1 1/2" Levelling Feet. (page 7)

## Preparation For Installation:

1. Install 3/4" MPT boiler drain in the fitting as shown. Either side can be utilized. Note: If using the supply and return on each side, either one of the returns is going to need the drain valve incorporated.

**Note: Use Teflon pipe thread sealant or Teflon tape on ALL threads before connections are made.**

2. Install the 1/2" MPT temperature/pressure gauge in fitting where shown.

3. Locate and install the outside air temperature sensor. Location of this sensor should be on the North side of the home or building and out of direct sunlight. Use a cat3 cable or 18-2 thermostat wire to attach the sensor to the terminals located beside the control board. The wires can be connected to the sensor with wire nuts or butt splice connectors.

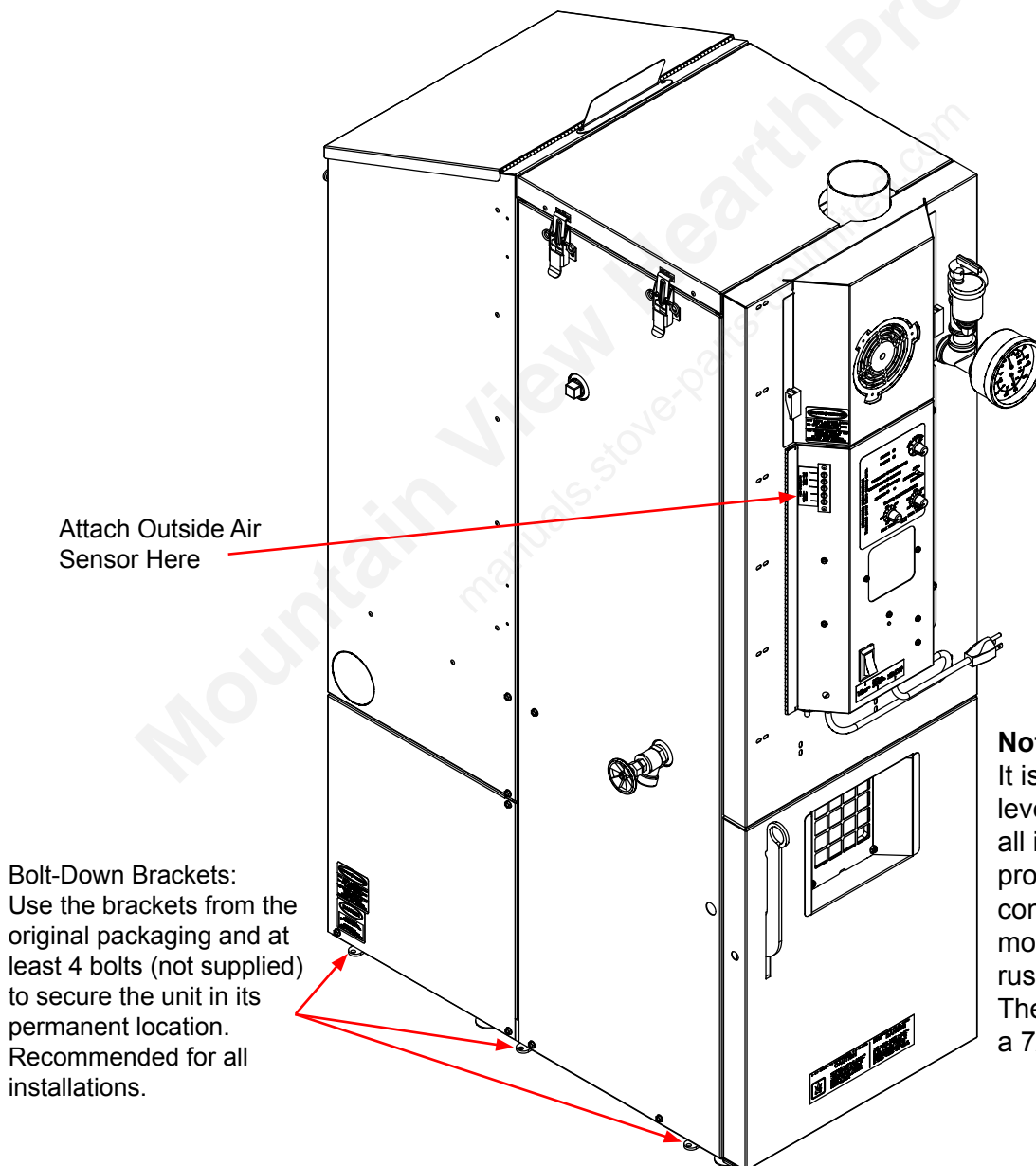

### Note:

It is recommended that the levelling feet be installed in all installations. The air space provided will help to prevent condensation or trapped moisture which may lead to rust on the bottom of the unit. The feet can be adjusted using a 7/16" open end wrench.

# Installation

## Minimum non-combustible floor protection area

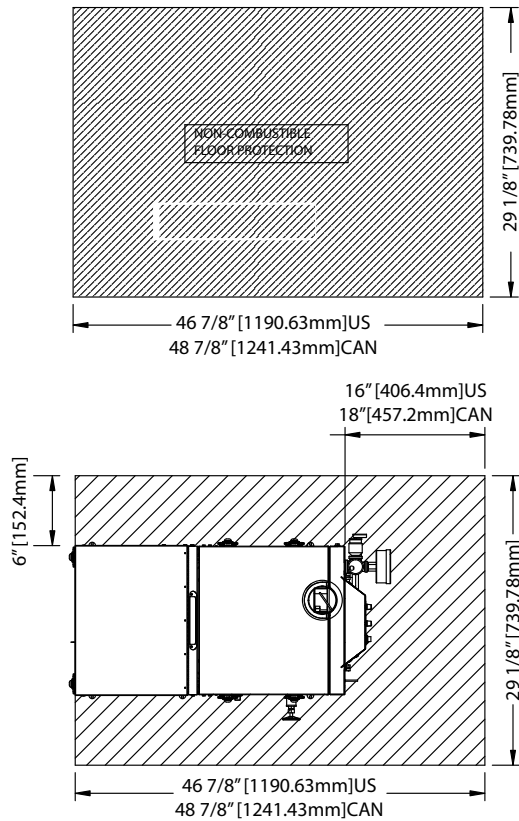

### Floor Protection:

The striped area indicates the minimum required floor protection area if the boiler is going to be placed on a combustible floor. **Special Note: When installing on a protected floor, the levelling feet need to be adjusted so that the bottom of the unit is 1¼ inches off the floor protector (see illustration below).** This boiler requires 46<sup>7</sup>/<sub>8</sub>" X 29<sup>1</sup>/<sub>8</sub>" (48<sup>7</sup>/<sub>8</sub>" X 29<sup>1</sup>/<sub>8</sub>" in Canada) of non combustible floor protection as shown above. 16" (US) or 18" (Canada) of the floor protection must be in front of the boiler as shown, with 6" extending on either side. CSA/CAN B366.1 requires floor protection extending 2" (50mm) under horizontal section of chimney connector. Floor protection must be a minimum of 26 gauge sheet metal.

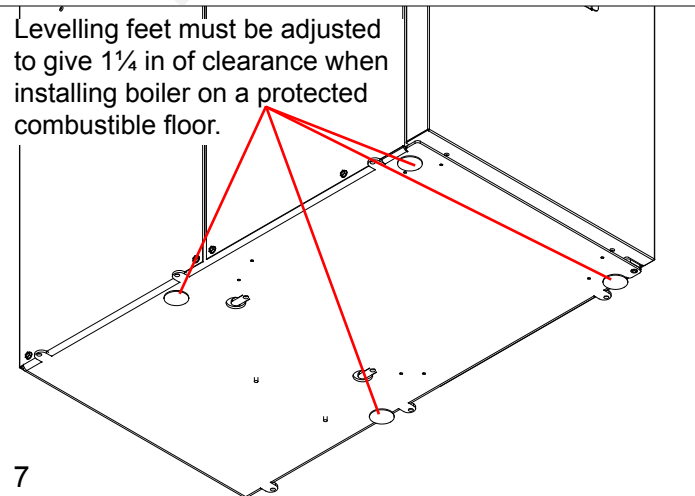

### Placement and System Design:

The first thing that needs to be done is deciding where and how the boiler will be installed.

Things that need to be taken into consideration are the intended use of the boiler. For example, is the boiler going to be used as a secondary or backup heating system? If it is to be used in conjunction with an existing oil or gas boiler system will it be piped in parallel or in series? The answers to these and other questions can be determined by talking to your certified dealer or a qualified HVAC or plumbing contractor. This will ensure that the boiler is installed and piped to best accommodate your needs and expectations.

Much consideration must be given to the venting. Due to low exhaust gas temperatures, the boiler should be placed where the venting system can be as short as possible. Pay particular attention to electrical connection needs and combustible/service clearance requirements.

After the boiler is set into place the venting can be installed.

Make sure any exhausting devices or appliances used in the area are installed so as not to create negative pressure in the room where the boiler is located.

This boiler must not be installed in an area or room where chemicals or solvents are used or stored in quantities above that of normal use.

### Note:

It is recommended that the levelling feet be installed in all installations. The air space provided will help to prevent condensation or trapped moisture which may lead to rust on the bottom of the unit.

The feet can be adjusted using a 7/16" open end wrench.

**This appliance is also approved for installation into a shop.**

# Installation

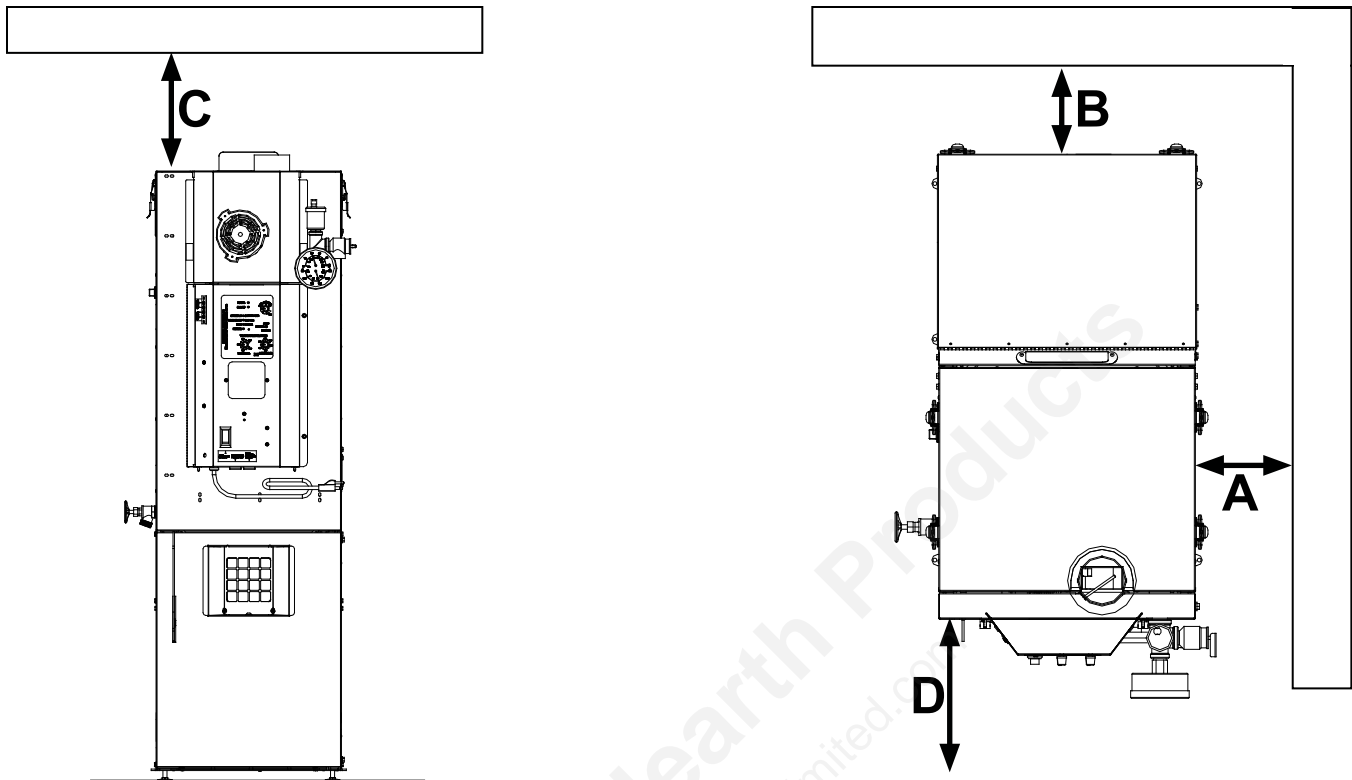

## Minimum Clearances To Combustible Materials

Sidewall To Appliance A	6" (152 mm)	Mur Latéral à l'Appareil
Backwall To Appliance B	6" (152 mm)	Mur Arrière à l'Appareil
Stove Top To Ceiling C	16" (406 mm)	Haut du Poêle au Plafond
Stove Front To Combustibles D	48" (1219 mm)	Des Combustibles au Devant du Poêle
Combustibles To Pellet Vent	3" (76 mm)	Matériaux Combustibles au Conduit de Fumée
Minimum Alcove Height	72" (1829 mm)	Hauteur de l'Alcôve
Minimum Alcove Width	48" (1219 mm)	Largeur de l'Alcôve
Minimum Alcove Depth	60" (1524 mm)	Profondeur de l'Alcôve

**WARNING! RISK OF FIRE!** Hearth & Home Technologies disclaims any responsibility for, and the warranty and agency listing will be voided by the following actions:

**DO NOT:**

- Install or operate a damaged appliance
- Modify the appliance
- Install other than as instructed by Hearth & Home Technologies
- Operate the appliance without fully assembling all components
- Overfire the appliance
- Install any component or part not approved by Hearth & Home Technologies

Improper installation, adjustment, alteration, service, or maintenance can cause injury or property damage. For assistance or additional information, consult a qualified installer, service agency or your dealer.

# Venting

## Requirements for Terminating the Venting

**WARNING:** Venting terminals must not be recessed into a wall or siding.

**NOTE:** Only PL vent pipe wall pass-throughs and fire stops should be used when venting through combustible materials.

**NOTE:** Always take into consideration the effect the prevailing wind direction or other wind currents will cause with flyash and /or smoke when placing the termination.

### In addition, the following must be observed:

- A. The clearance above grade must be a minimum of 18".<sup>1</sup>
- B. The clearance to a window or door that may be opened must be a minimum of 48" to the side, 48" below the window/door, and 12" above the window/door.<sup>1</sup>
- C. A 12" clearance to a permanently closed window is recommended to prevent condensation on the window.
- D. The vertical clearance to a ventilated soffit located above the terminal within a horizontal distance of 2 feet (60 cm) from the center-line of the terminal must be a minimum of 18".
- E. The clearance to an unventilated soffit must be a minimum of 12".
- F. The clearance to an outside corner is 11" from center of pipe.
- G. The clearance to an inside corner is 12". *If you see deposits developing on the wall, you may need to extend this distance to accommodate your installation conditions.*
- H. A vent must not be installed within 3 feet (90 cm)

above a gas meter/regulator assembly when measured from the horizontal center-line of the regulator.<sup>1</sup>

I. The clearance to service regulator vent outlet must be a minimum of 6 feet.<sup>1</sup>

J. The clearance to a non-mechanical air supply inlet to the building or the combustion air inlet to any other appliance must be a minimum of 48".<sup>1</sup>

K. The clearance to a mechanical air supply inlet must be a minimum of 10 feet.<sup>1</sup>

L. The clearance above a paved sidewalk or a paved driveway located on public property must be a minimum of 7 feet.<sup>1,2</sup>

M. The clearance under a veranda, porch, deck or balcony must be a minimum of 12 inches.<sup>1,3</sup> **(See B. also)**

**NOTE:** The clearance to vegetation and other exterior combustibles such as mulch is 36" as measured from the center of the outlet or cap. This 36" radius continues to grade or a minimum of 7 feet below the outlet.

<sup>1</sup>Certain Canadian and or Local codes or regulations may require different clearances.

<sup>2</sup>A vent shall not terminate directly above a sidewalk or paved driveway which is located between two single family dwellings and serves both dwellings.

<sup>3</sup>Only permitted if veranda, porch, deck, or balcony is fully open on a minimum of 2 sides beneath the floor.

**NOTE:** Where passage through a wall, or partition of combustible construction is desired, the installation shall conform to CAN/CSA-B365. (if in Canada)

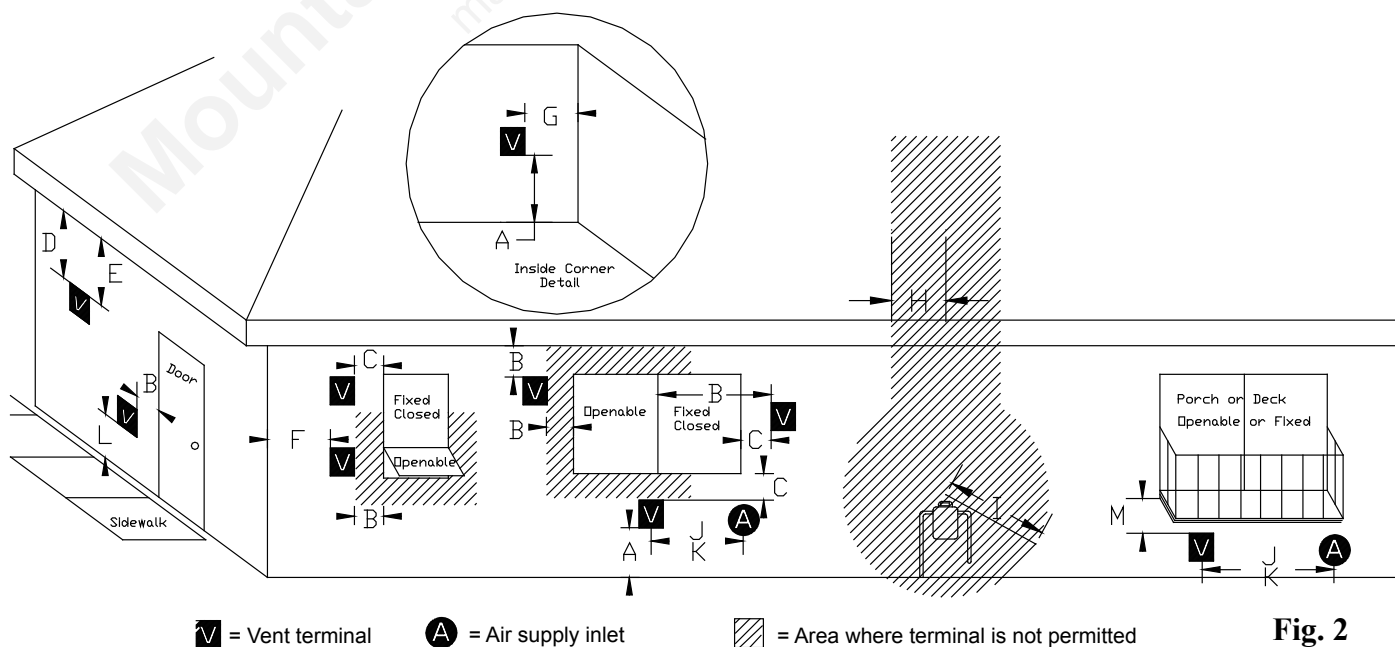

**Fig. 2**

# Venting

## Venting

Use only 3" pellet vent pipe to vent your pellet boiler. A combustion blower is used to extract the combustion gases from the firebox. This creates a negative pressure in the firebox and a positive pressure in the venting system as shown in Fig. 4. The longer the vent pipe and more elbows used in the system, the greater the flow resistance, and the greater the chance for creosote accumulation. Because of these facts we recommend using as few elbows as possible and 18 feet or less of vent pipe. The maximum horizontal run should never exceed 8 feet.

**Be sure to use wall and ceiling pass through fittings (which are approved for pellet vent pipe ) when going through combustible materials.** Be sure to use a starting collar to attach the venting system to the stove. **The starting collar must be sealed to the stove flue collar with high temp silicone caulking or aluminum tape, and screwed into the units' flue collar in a minimum of three (3) places.**

**Due to low exhaust temperatures, increasing the diameter of the venting or exceeding the recommendations of the venting graph, is strongly discouraged.**

## Vent Pipe

3" pellet vent pipe (also known as "L or PL" vent) is constructed of two layers with air space between the layers. This air space acts as an insulator and reduces the outside surface temperature to allow a minimum clearance to combustibles as low as 1 inch. In Canada the minimum clearance to combustibles is 3 inches. Check with the venting manufacturer to be certain of specified clearances.

The sections of pipe lock together to form an air tight seal in most cases; however, in some cases a perfect seal is not achieved. For this reason and the fact that the unit operates with a positive vent pressure, **we specify that all joints within the structure should be secured with at least 3 screws, and sealed with silicone caulking.**

**Creosote - Formation and Need for Removal** - When wood is burned slowly, it produces tar and other organic vapors, which combine with expelled moisture to form creosote. The creosote vapors condense in the relatively cool chimney flue of a slow-burning fire. As a result, creosote residue accumulates on the flue lining. When ignited, this creosote makes an extremely hot fire. The pellet vent pipe should be inspected at least twice monthly during the heating season to determine if a creosote buildup has occurred. If creosote has accumulated it should be removed to reduce the risk of a chimney fire.

*Guidance on minimizing creosote formation and the need for periodic creosote removal:* The chimney should be inspected during the heating season to determine if a creosote build-up has occurred. If a significant layer of creosote has accumulated, 1/8" (3mm) or more, it should be removed to reduce the risk of a chimney fire.

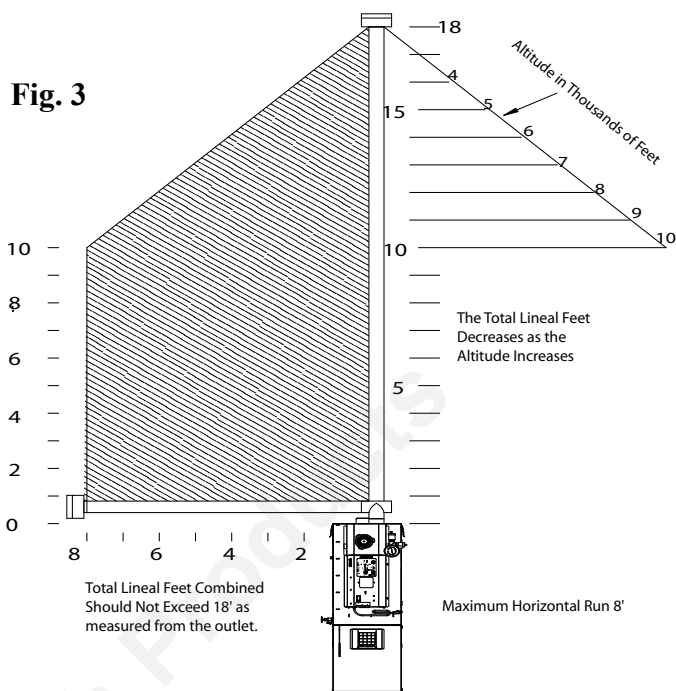

**NOTE: Use only 3" diameter type "L" or "PL" venting system. Be sure to inspect and clean exhaust venting system frequently.**

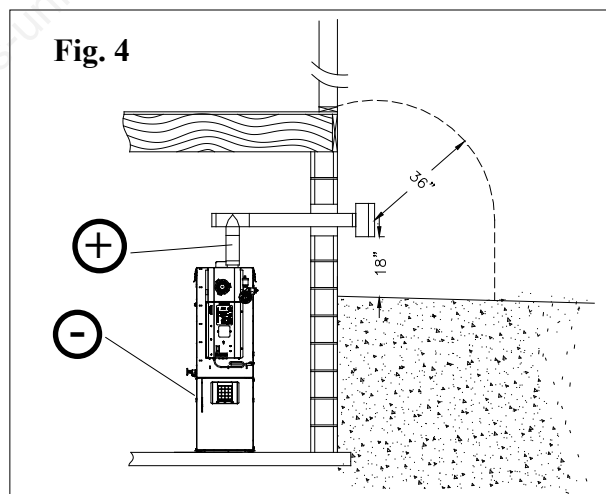

# Venting

The minimum vent configuration is a 90° or Tee on a starter collar and a 24" length horizontal through an exterior wall. A cap on the end should direct the flue gases down and away from the structure. See Fig. 5.

The maximum horizontal length is 8 feet. The minimum termination height above the exterior grade is 18". The maximum total length of any configuration is 18 feet\*.

\* (see venting graph on page 10 for exceptions)

**NOTE: Cleanout Tee's should always be used on the transitions to horizontal pipe to allow easy access for cleaning.**

The venting graph allows for one(1) 90 deg. or Tee fitting in any configuration.

If more 90's, T's, or 45's are needed the total length must be adjusted to allow for the added restriction.

Up to four (4) additional 90's, Tee's, or equivalent 45's can be added as long as the overall length is adjusted in accordance with the values listed below.

(See the venting graph on page 10.)

Each Vertical ---- 90 deg. or T	subtract 2.5 feet
Each Vertical ---- 45 deg.	subtract 1.5 feet
Each Horizontal - 90 deg. or T	subtract 5.0 feet
Each Horizontal - 45 deg.	subtract 2.5 feet

## Venting Into An Existing Chimney

The boiler may be vented into an existing masonry or Class A metal chimney, providing that the chimney is less than 20 feet above the connector. A flue liner, no more than 4-inch diameter, must be installed, along with a termination cap and the proper flashing to seal the existing flue.

**The venting Can Not** be installed in a chimney serving another appliance.

The chimney should be cleaned and/or inspected before installation of the vent liner.

Due to low exhaust temperatures, and the increased possibility of condensation and creosote formation, additional measures may need taken to increase the flue temperature. One such measure would be to remove the two rear-most spiral baffles, above the burn pot, from their heat exchange tubes. Although some efficiency will be lost, an increased flue temperature will result.

The flue liner should be inspected frequently, during operation, to monitor its performance and cleanliness.

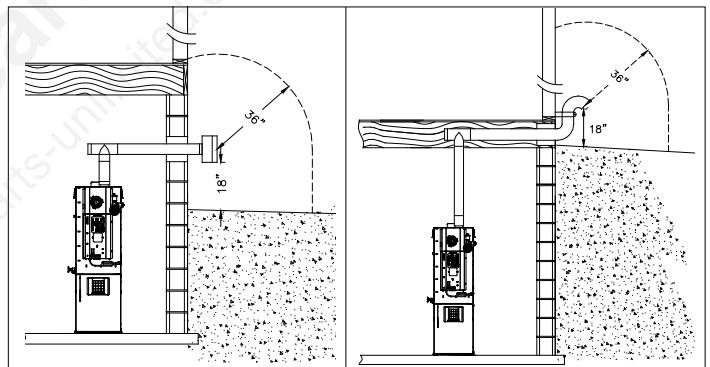
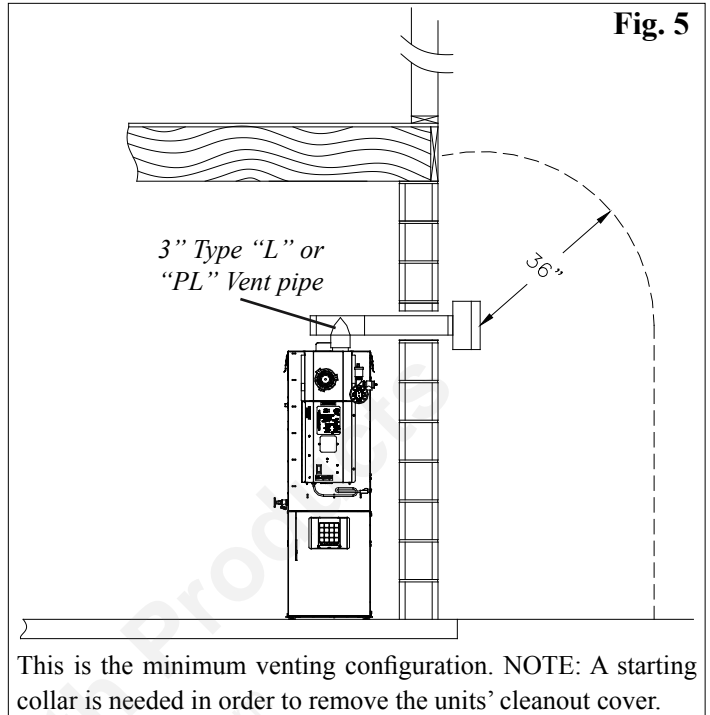

Other examples of possible installations of the venting.

**Any exterior venting (vent pipe exposed to outside ambient temperatures) should be kept to a minimum, due to potential condensation problems.** This is especially important in high humidity-cold weather climates, such as maritime areas, lake shores, and low river valleys.

**NOTE: Use only 3" diameter type "L" or "PL" venting system. Be sure to inspect and clean exhaust venting system frequently.**

# Venting Installation

To reduce probability of reverse drafting during a power failure, Hearth & Home Technologies strongly recommends:

- Installing the pellet vent with a minimum vertical rise of five feet. Preferably terminating above the roof line.

- Installing an outside air connection to the appliance.

**To prevent soot damage to exterior walls, and to prevent re-entry of soot or ash into the home:**

- Maintain specified clearances to windows, doors and air inlets, including air conditioners.

- Vents should not be placed below ventilated soffits.

- Avoid venting into alcove locations.

- Vents should not terminate under overhangs, decks or onto covered porches.

- Maintain minimum clearance of 12” from the vent termination to the exterior wall.

**Hearth & Home Technologies assumes no responsibility for, nor does the warranty extend to, smoke damage caused by reverse drafting of pellet appliances under power failure conditions.**

*NOTE: Read and follow all of the vent pipe manufacturers’ instructions on the proper installation and support of the vent pipe. Adhere to all clearances to combustibles.*

## WARNING

**KEEP COMBUSTIBLE MATERIALS SUCH AS GRASS, LEAVES, ETC. AT LEAST 3 FEET AWAY FROM THE POINT DIRECTLY UNDER THE VENT TERMINATION. (BETWEEN THE VENT AND THE GROUND)**

## CAUTION

**KEEP COMBUSTIBLES AWAY FROM FLUE OUTLET.**

**INSTALLATION IS TO BE PERFORMED BY A QUALIFIED INSTALLER.**

*NOTE: All installation clearances and restrictions must be adhered to.*

*NOTE: Use only 3” diameter type “L” or “PL” venting system. Be sure to inspect and clean exhaust venting system frequently.*

**INSTALLATION IS TO BE PERFORMED BY A QUALIFIED INSTALLER.**

**DO NOT INSTALL A FLUE DAMPER IN THE EXHAUST VENTING SYSTEM OF THIS UNIT.**

**DO NOT CONNECT THIS UNIT TO A CHIMNEY FLUE SERVING ANOTHER APPLIANCE.**

**INSTALL VENT WALL PASS-THROUGHS AT CLEARANCES SPECIFIED BY THE VENT MANUFACTURER.**

# Installation

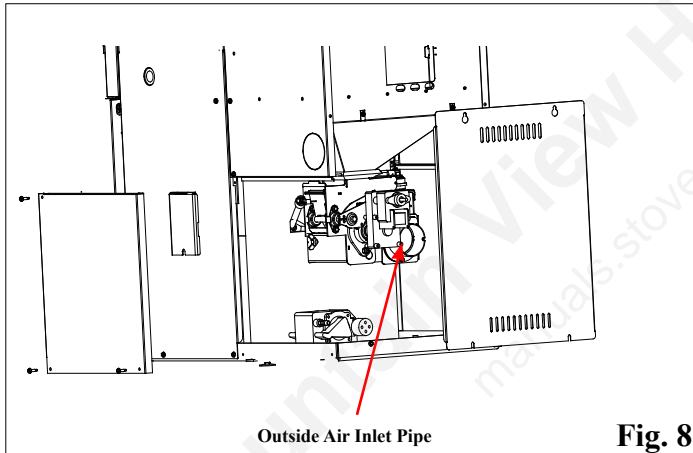
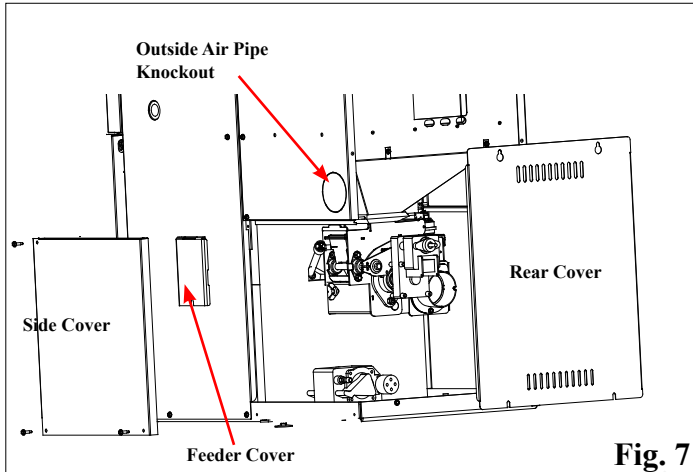
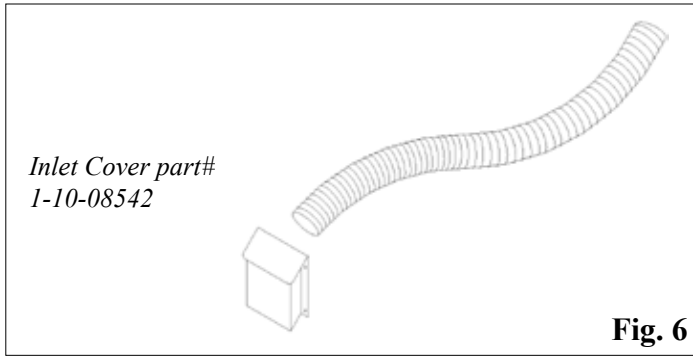

## Outside Air

Although strongly recommended, the use of outside air is optional, except where required by local building codes. To install outside air, use metal flex pipe, part # 1-00-08543 (25' roll) See Fig. 6. There is a break-away hole on either rear panel which must be removed before connecting the flex pipe. See Fig. 7. The pipe should be run outside and terminate 3 feet or more below or 1 foot or more to the side of the vent pipe outlet. Never terminate the outside air above the vent pipe outlet. The maximum length of this pipe is 15 feet. Inlet cover part number 1-10-08542 should be used to keep birds, rodents etc.out of the inlet pipe. See Fig.6.

**NOTE:** If outside air is installed, the inlet cover should not be placed in an area where drifting of snow or ice will build up, blocking the intake air supply.

Hearth & Home Technologies strongly recommends the use of outside air for all pellet boiler applications.

Per national building codes, consideration must be given to combustion air supply for all appliances in the vicinity of the pellet boiler. Failure to supply adequate combustion air for all appliance demands may lead to backdrafting of those appliances. Consult with your HVAC Professional to determine that all combustion air requirements are met.

**When the appliance is side-wall vented:** The air intake is best located on the same exterior wall as, and lower than the exhaust vent outlet.

**When the appliance is roof vented:** The air intake is best located on the exterior wall oriented towards the prevailing wind direction, during the heating season.

The Outside Air Intake Pipe is inside the Rear Cover and to the right of the feeder motor. The flex pipe is made to slide inside the Air Intake Pipe. See Fig. 8. It should be held into place with silicone, foil tape, or a hose clamp. (not supplied)

## Negative Pressure and Electrical Power Failure

To reduce the probability of back-drafting or burn-back in the pellet appliance during a power failure, the appliance must be able to draft naturally without exhaust blower operation. Negative pressure in the house will resist this natural draft if not accounted for in the pellet appliance installation.

Heat rises in the house and leaks out at upper levels. This air must be replaced with cold air from outdoors which flows into lower levels of the house. Vents and chimneys into basements and lower levels can become the conduit for air supply and reverse under these conditions.

The outside air supply will supply most of the demands of the pellet appliance to resist back-drafting, but consideration must be given to the total house demand. It may be necessary to add additional ventilation to the space in which the pellet appliance is located. Consult with your HVAC professional to determine the ventilation demands for your house.

**During a loss of electrical power the hopper lid must be kept in a closed and latched position. Opening the lid while the combustion blower is non-operational will allow smoke into the home and potential overheating of the hopper and fuel. This can lead to a fire in the hopper.**

# Installation-Plumbing

TYPICAL BOILER HOT WATER PIPING SHOWING AIR REMOVAL SYSTEM, PROVISIONS FOR THE EXPANSION OF WATER AND THE AUTOMATIC COLD WATER SUPPLY. ALSO SHOWN BUT NOT NECESSARILY NEEDED IS THE BOILER BYPASS LINE. THE NECESSITY OF THIS LINE WILL BE DETERMINED BY THE INSTALLING CERTIFIED PLUMBER OR HVAC CONTRACTOR.

NOTE: ALWAYS REFER TO THE INDIVIDUAL COMPONENTS RECOMMENDED INSTALLATION INSTRUCTIONS FOR THE PROPER MOUNTING POSITION AND LOCATION WITHIN THE PIPING SYSTEM.

**NOTICE:** When installing with the Atmospheric Conversion, all of the pressurized system components shown are not necessary. Air vents or bleeders should be removed from the plumbing system to prevent air from entering the lines.

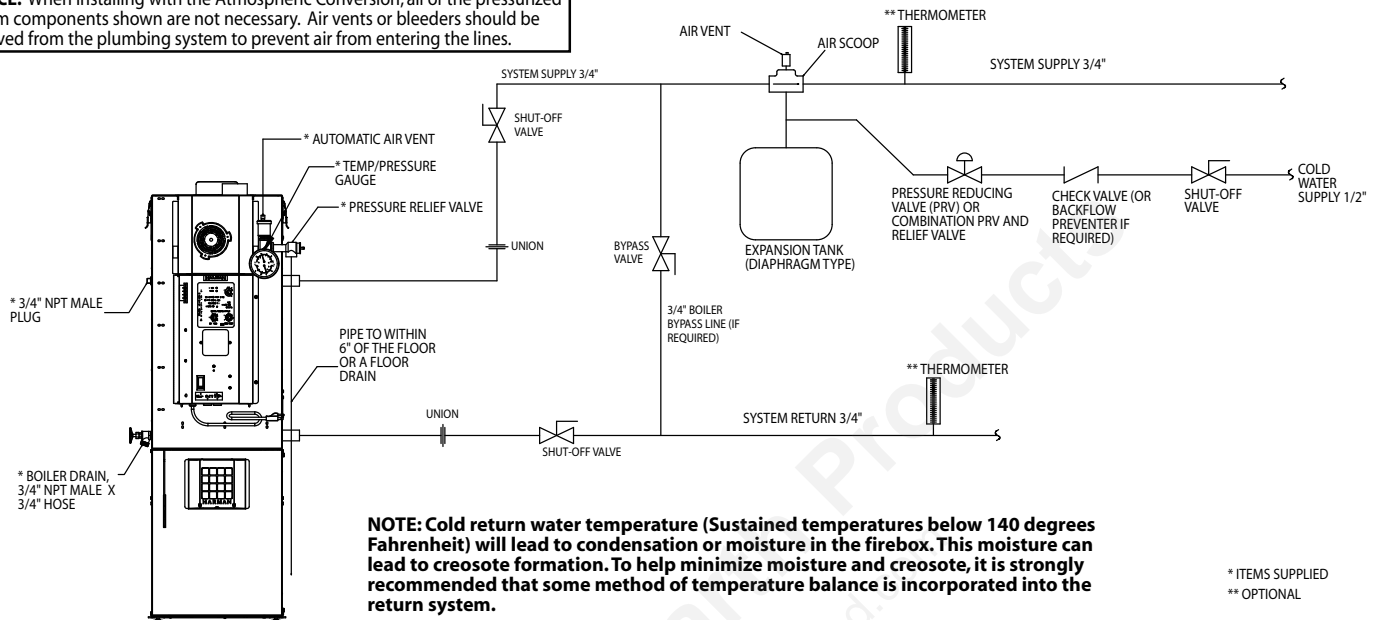

EXAMPLE OF A TYPICAL MULTI-ZONE HEATING SYSTEM WITH BOILER BYPASS AND INDIRECT DOMESTIC HOT WATER ZONE

**NOTICE:** When installing with the Atmospheric Conversion, all of the pressurized system components shown are not necessary. Air vents or bleeders should be removed from the plumbing system to prevent air from entering the lines.

NOTE: ALWAYS REFER TO THE INDIVIDUAL COMPONENTS RECOMMENDED INSTALLATION INSTRUCTIONS FOR THE PROPER MOUNTING POSITION AND LOCATION WITHIN THE PIPING SYSTEM.

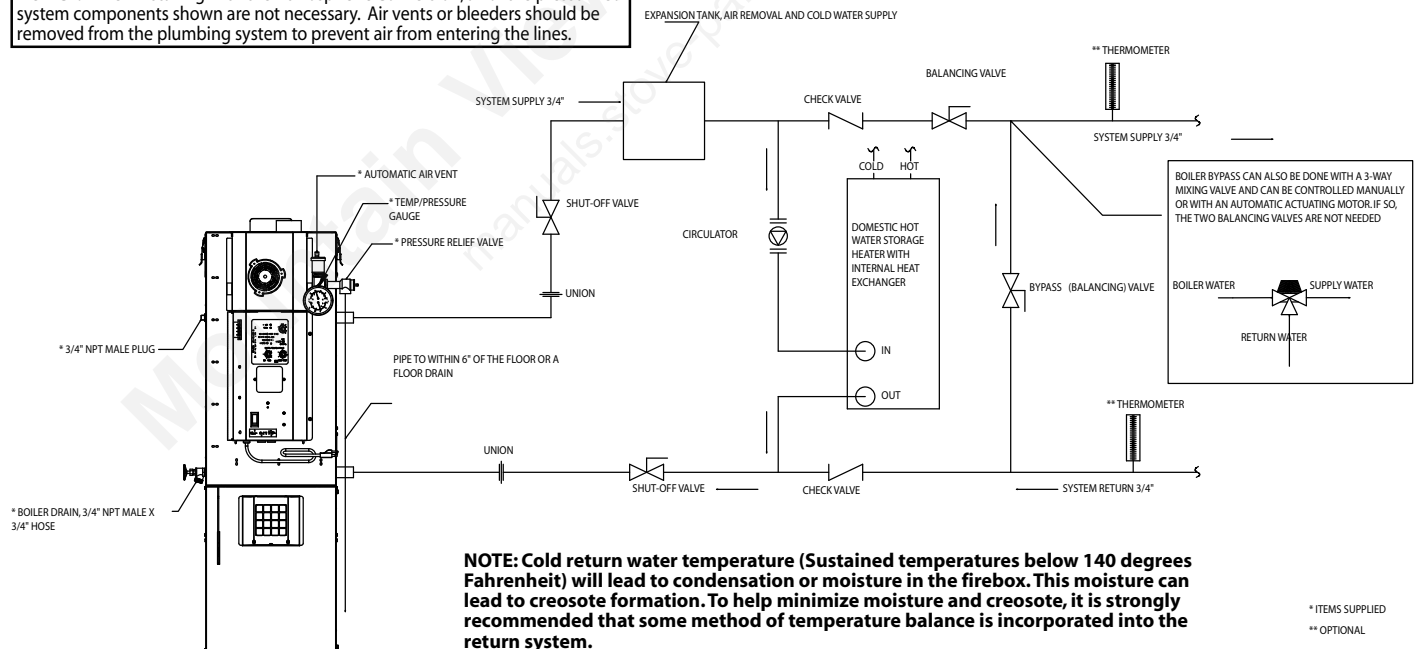

# Installation-Plumbing

## Boilers intended to be connected to an existing boiler or boiler system shall:

1. Be capable of being installed without interfering with the normal delivery of heated water from the original boiler to the radiation system.
2. Be capable of being installed to operate as intended without affecting the operation of the electrical and mechanical safety controls of the original boiler.
3. Provide, upon completion of the installation, for a change over from one fuel to the other without requiring the manual adjustment of any controls or components other than the thermostats.
4. Be compatible with the operation of a service water-heating coil within the original boiler without bypassing the operation of the solid-fuel boiler.
5. Have provision for preventing, or adequate water capacity within the boiler to prevent, damage to the boiler from loss of circulation due to electrical power failure.
6. Be capable of being installed without changing the function of the control or rewiring of the original boiler. A wiring interconnection is permitted. The electrical system of both boilers shall be powered from a single branch circuit without exception.

(CAN/CSA-B366.1-M91)

7. Pertaining to CAN/CSA- B365-01, Have a clearly labelled device, located at each entrance to the boiler area, which can be thrown to discontinue operation to the feed system.

## Anti-freeze and/or boiler water treatment:

There is no restriction on the type of commercial antifreeze used. When filling the boiler water system, it is recommended that some form of boiler water treatment be used.

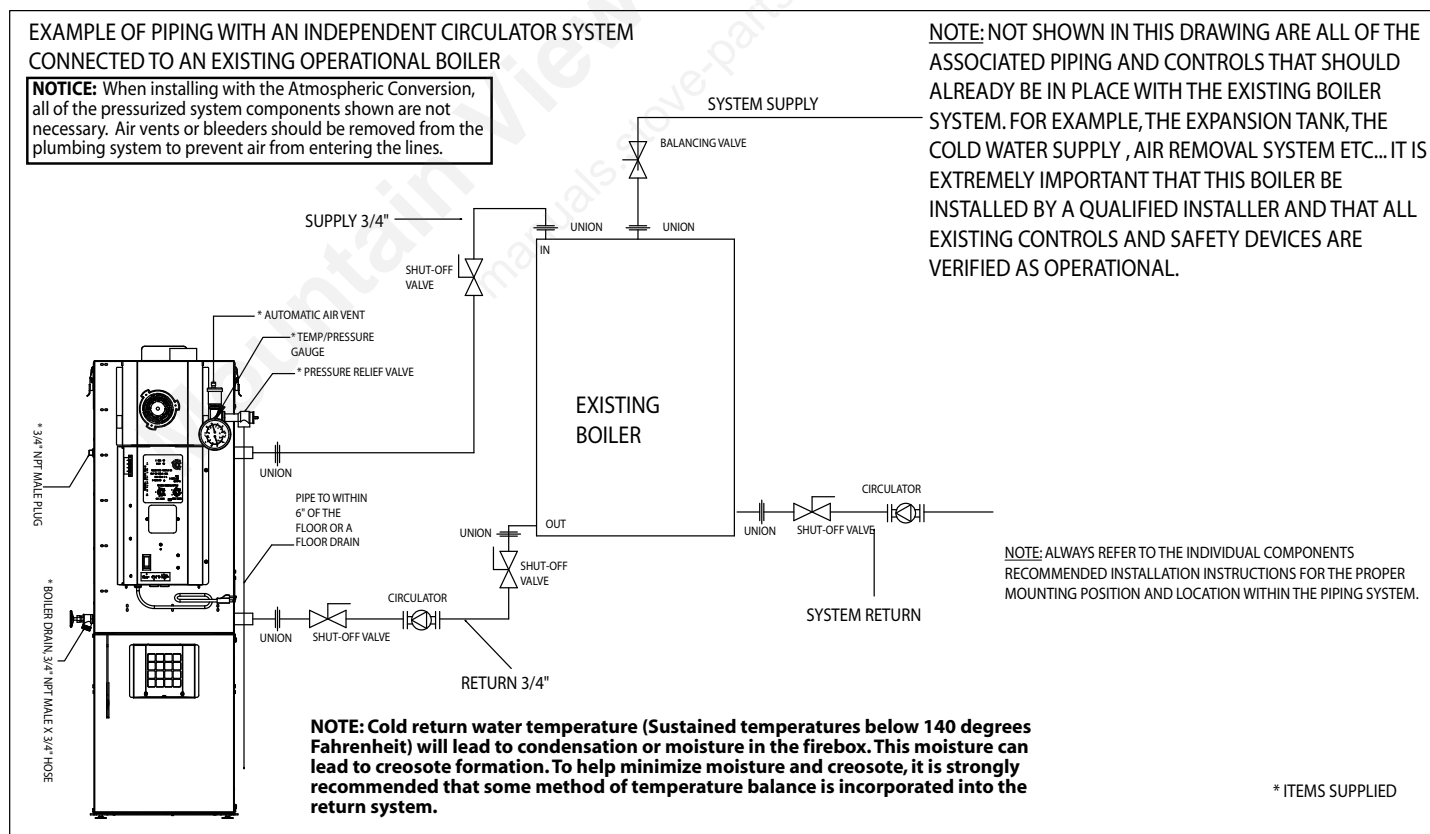

# Installation-Plumbing

## EXAMPLE OF PIPING IN SERIES WITH AN EXISTING OPERATIONAL BOILER

**NOTICE:** When installing with the Atmospheric Conversion, all of the pressurized system components shown are not necessary. Air vents or bleeders should be removed from the plumbing system to prevent air from entering the lines.

**NOTE:** ALWAYS REFER TO THE INDIVIDUAL COMPONENTS RECOMMENDED INSTALLATION INSTRUCTIONS FOR THE PROPER MOUNTING POSITION AND LOCATION WITHIN THE PIPING SYSTEM.

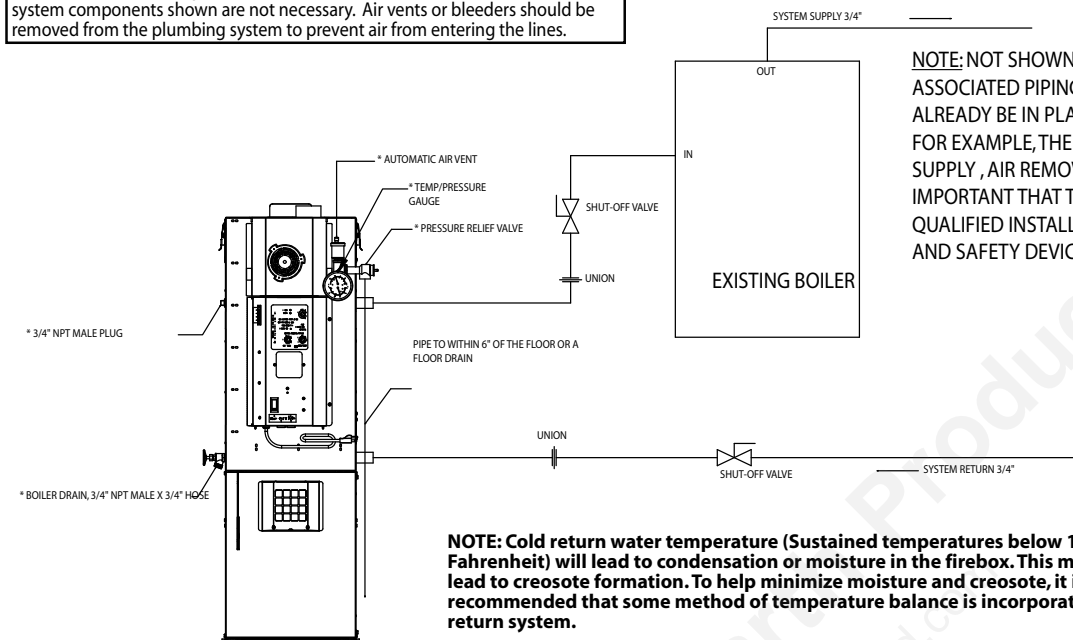

**NOTE:** NOT SHOWN IN THIS DRAWING ARE ALL OF THE ASSOCIATED PIPING AND CONTROLS THAT SHOULD ALREADY BE IN PLACE WITH THE EXISTING BOILER SYSTEM. FOR EXAMPLE, THE EXPANSION TANK, THE COLD WATER SUPPLY, AIR REMOVAL SYSTEM ETC... IT IS EXTREMELY IMPORTANT THAT THIS BOILER BE INSTALLED BY A QUALIFIED INSTALLER AND THAT ALL EXISTING CONTROLS AND SAFETY DEVICES ARE VERIFIED AS OPERATIONAL.

## EXAMPLE OF PIPING IN PARALLEL WITH AN EXISTING OPERATIONAL BOILER

**NOTICE:** When installing with the Atmospheric Conversion, all of the pressurized system components shown are not necessary. Air vents or bleeders should be removed from the plumbing system to prevent air from entering the lines.

**NOTE:** ALWAYS REFER TO THE INDIVIDUAL COMPONENTS RECOMMENDED INSTALLATION INSTRUCTIONS FOR THE PROPER MOUNTING POSITION AND LOCATION WITHIN THE PIPING SYSTEM.

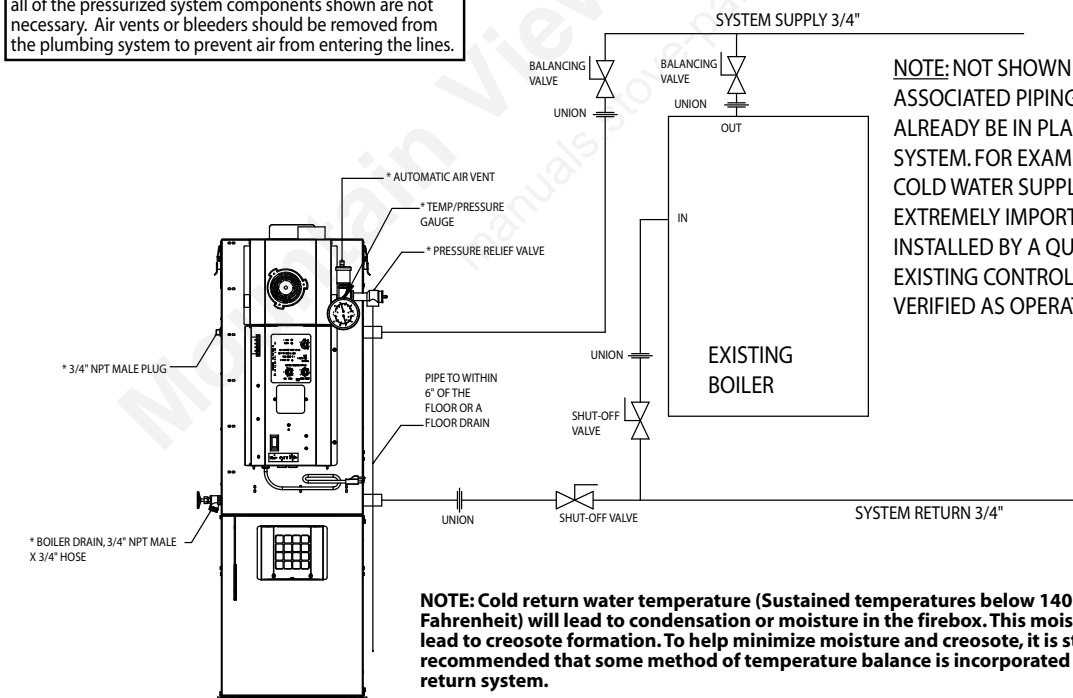

**NOTE:** NOT SHOWN IN THIS DRAWING ARE ALL OF THE ASSOCIATED PIPING AND CONTROLS THAT SHOULD ALREADY BE IN PLACE WITH THE EXISTING BOILER SYSTEM. FOR EXAMPLE, THE EXPANSION TANK, THE COLD WATER SUPPLY, AIR REMOVAL SYSTEM ETC... IT IS EXTREMELY IMPORTANT THAT THIS BOILER BE INSTALLED BY A QUALIFIED INSTALLER AND THAT ALL EXISTING CONTROLS AND SAFETY DEVICES ARE VERIFIED AS OPERATIONAL.

# Installation-Plumbing

TYPICAL BOILER HOT WATER PIPING SHOWING AIR REMOVAL SYSTEM, PROVISIONS FOR THE EXPANSION OF WATER AND THE AUTOMATIC COLD WATER SUPPLY. ALSO SHOWN IS THE AUTOMATIC MIXING VALVE. THIS COULD ALSO BE DONE BY (2) CLOSELY SPACED TEE'S. THE PROPER PIPING FOR THE INTENDED USE WILL BE DETERMINED BY THE INSTALLING CERTIFIED PLUMBER OR HVAC CONTRACTOR.

**NOTE:** ALWAYS REFER TO THE INDIVIDUAL COMPONENTS RECOMMENDED INSTALLATION INSTRUCTIONS FOR THE PROPER MOUNTING POSITION AND LOCATION WITHIN THE PIPING SYSTEM.

**NOTICE:** When installing with the Atmospheric Conversion, all of the pressurized system components shown are not necessary. Air vents or bleeders should be removed from the plumbing system to prevent air from entering the lines.

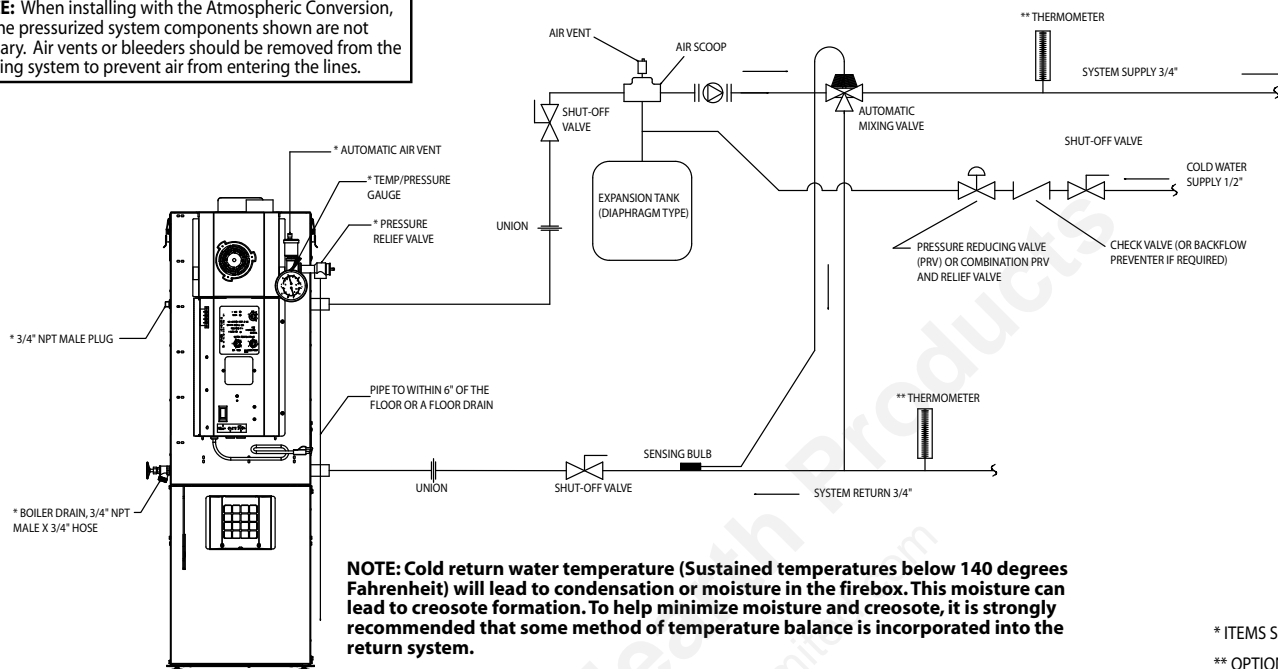

## EXAMPLE OF TYPICAL TANKLESS DOMESTIC HOT WATER PIPING

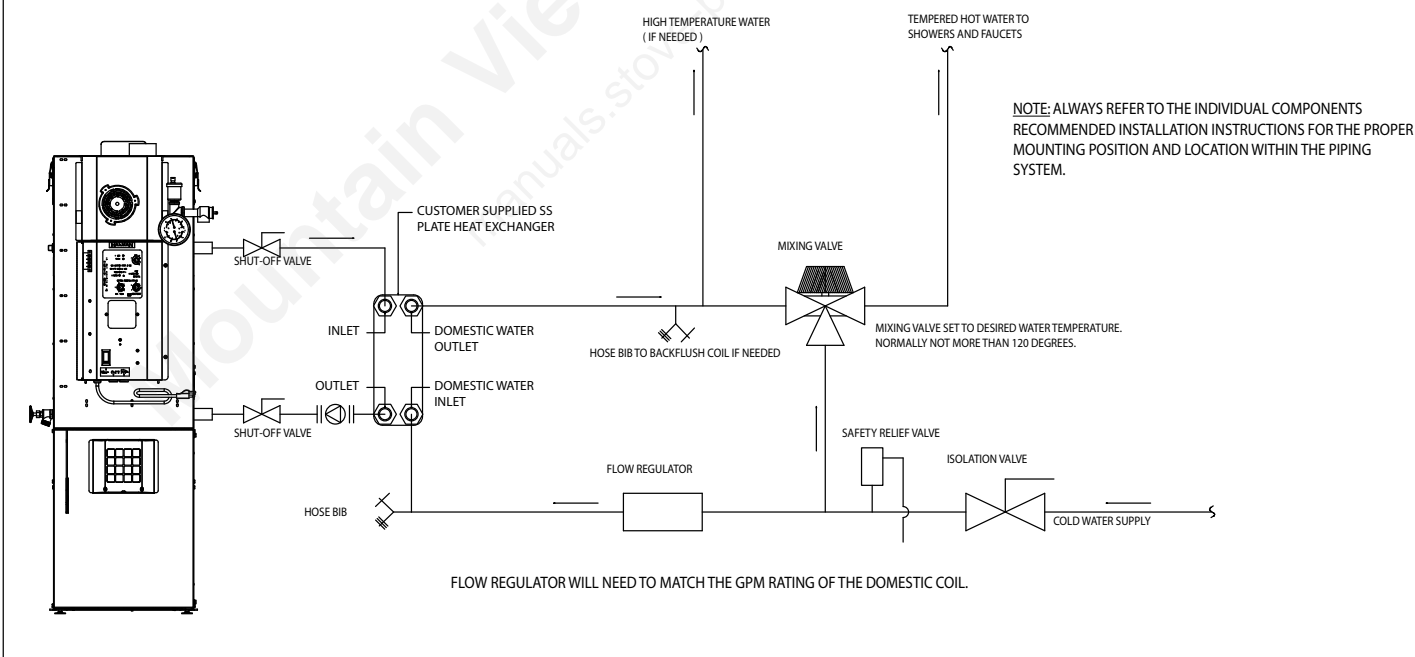

# Installation-Plumbing

## EXAMPLES OF TYPICAL DOMESTIC HOT WATER STORAGE PIPING

EXAMPLE #1

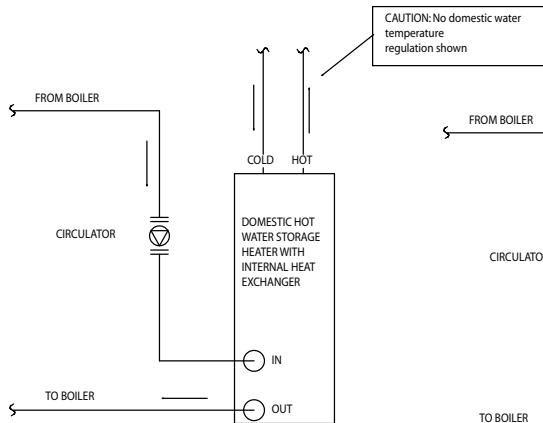

EXAMPLE #2

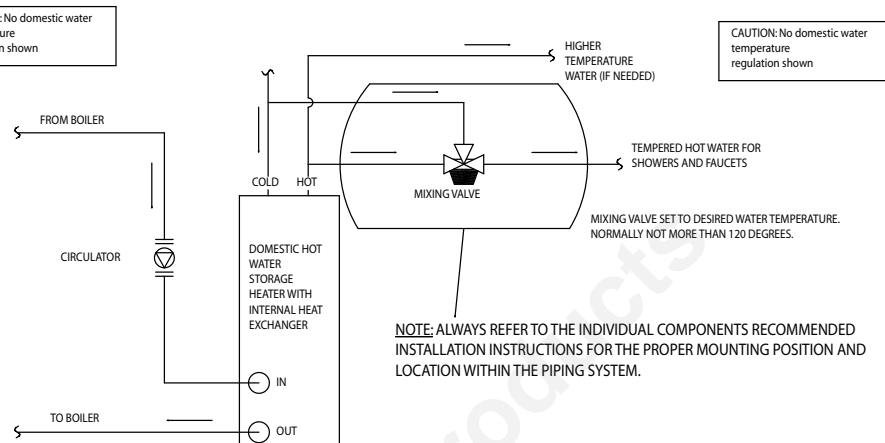

## EXAMPLE OF A TYPICAL MULTI-ZONE HEATING SYSTEM WITH A SINGLE CIRCULATOR AND INDIVIDUAL ZONE VALVES

NOTE: ALWAYS REFER TO THE INDIVIDUAL COMPONENTS RECOMMENDED INSTALLATION INSTRUCTIONS FOR THE PROPER MOUNTING POSITION AND LOCATION WITHIN THE PIPING SYSTEM.

**NOTICE:** When installing with the Atmospheric Conversion, all of the pressurized system components shown are not necessary. Air vents or bleeders should be removed from the plumbing system to prevent air from entering the lines.

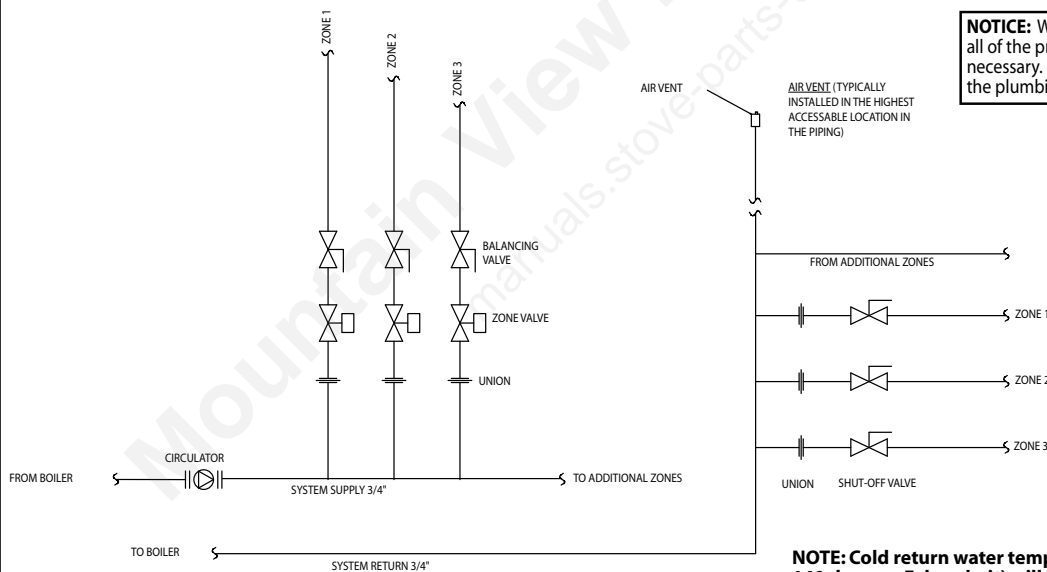

**NOTE:** Cold return water temperature (Sustained temperatures below 140 degrees Fahrenheit) will lead to condensation or moisture in the firebox. This moisture can lead to creosote formation. To help minimize moisture and creosote, it is strongly recommended that some method of temperature balance is incorporated into the return system.

# Installation-Plumbing

## EXAMPLE OF A COMBINATION HIGH/LOW MULTI-ZONE HEATING SYSTEM WITH INDIVIDUAL ZONE CIRCULATORS

**NOTICE:** When installing with the Atmospheric Conversion, all of the pressurized system components shown are not necessary. Air vents or bleeders should be removed from the plumbing system to prevent air from entering the lines.

NOTE: IF CIRCULATOR DOES NOT HAVE CHECK VALVE THEN A FLOW CONTROL VALVE WILL ALSO BE NEEDED AND INSTALLED IN THIS LOCATION

CIRCULATORS WITH INTEGRAL CHECK VALVE (SEE NOTE)

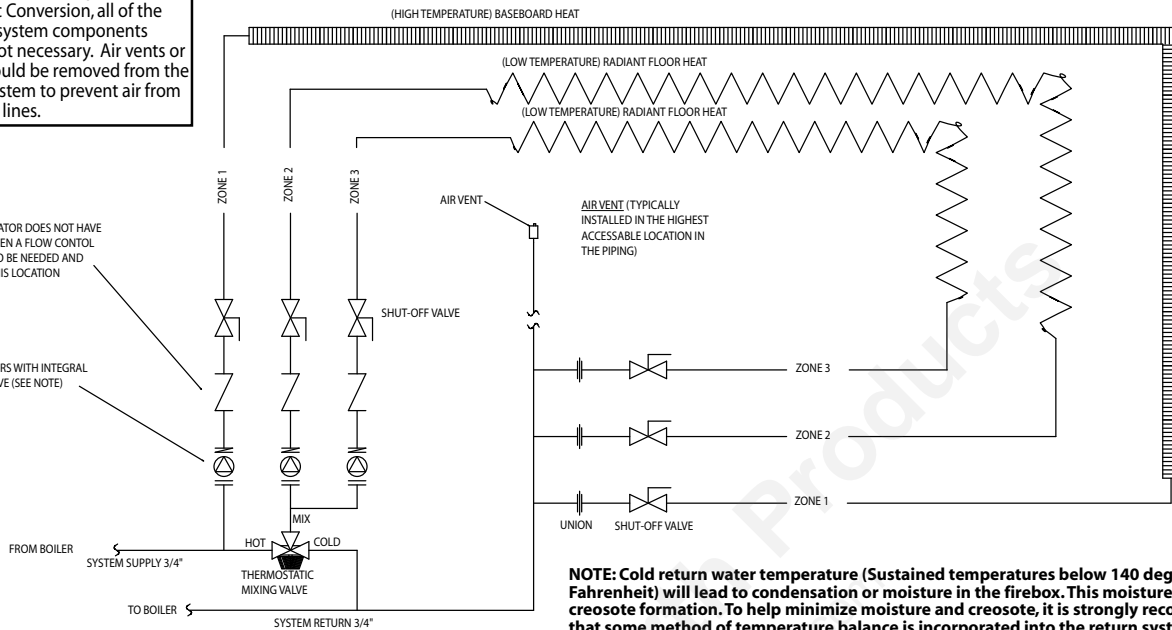

**NOTE:** ALWAYS REFER TO THE INDIVIDUAL COMPONENTS RECOMMENDED INSTALLATION INSTRUCTIONS FOR THE PROPER MOUNTING POSITION AND LOCATION WITHIN THE PIPING SYSTEM.

**NOTE:** Cold return water temperature (Sustained temperatures below 140 degrees Fahrenheit) will lead to condensation or moisture in the firebox. This moisture can lead to creosote formation. To help minimize moisture and creosote, it is strongly recommended that some method of temperature balance is incorporated into the return system.

## EXAMPLE OF A TYPICAL FORCED HOT AIR HEATING SYSTEM WITH THE BOILER DIRECT TO AN IN DUCT HOT WATER COIL

**NOTICE:** When installing with the Atmospheric Conversion, all of the pressurized system components shown are not necessary. Air vents or bleeders should be removed from the plumbing system to prevent air from entering the lines.

**NOTE:** ALWAYS REFER TO THE INDIVIDUAL COMPONENTS RECOMMENDED INSTALLATION INSTRUCTIONS FOR THE PROPER MOUNTING POSITION AND LOCATION WITHIN THE PIPING SYSTEM.

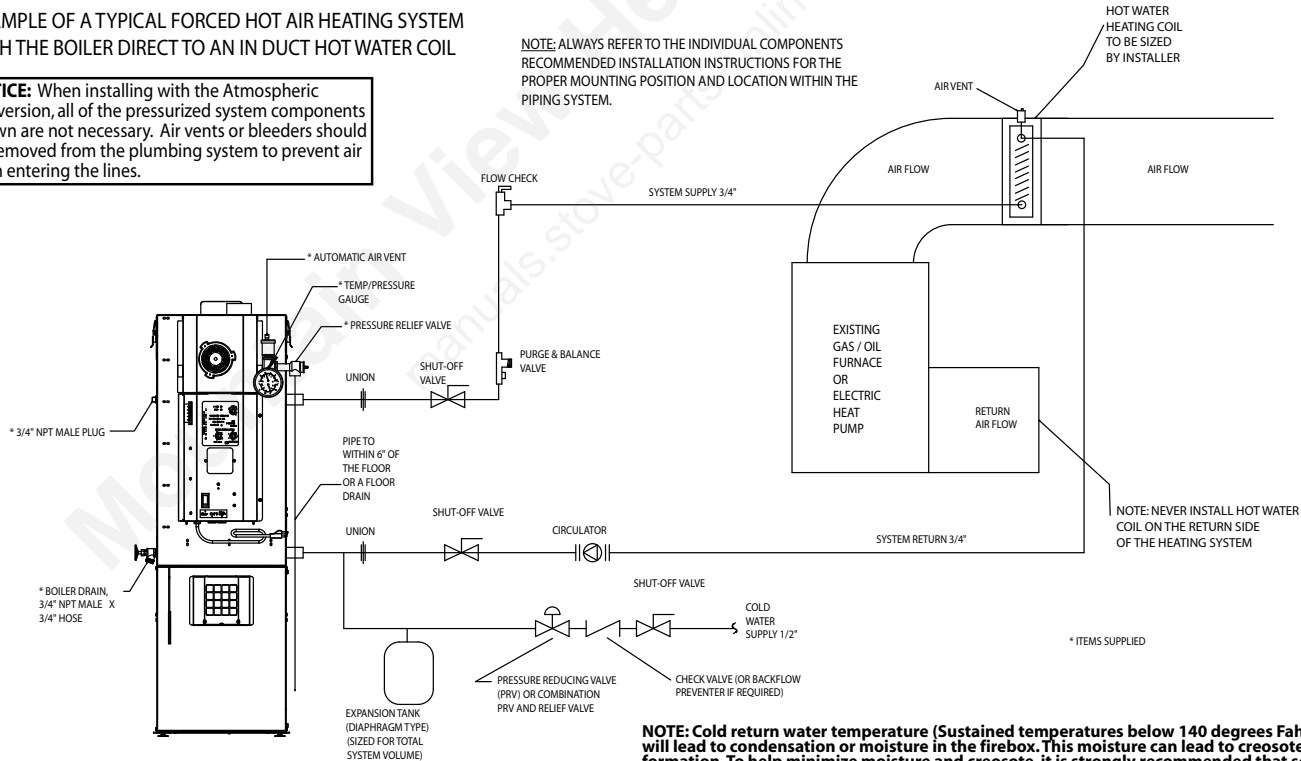

**NOTE:** Cold return water temperature (Sustained temperatures below 140 degrees Fahrenheit) will lead to condensation or moisture in the firebox. This moisture can lead to creosote formation. To help minimize moisture and creosote, it is strongly recommended that some method of temperature balance is incorporated into the return system.

# Installation With A Hot Air System

## Electrical interconnection of the HF60 to an existing heat pump, or fuel-fired hot air furnace:

Interconnection with a heat pump will generally require a second thermostat to be installed. It is recommended that a new electronic thermostat be installed as close to the existing thermostat as possible. Installing within one foot of the existing thermostat is recommended for ease of interconnection and similar temperature sensing ability.

If programmability is desired, both thermostats should have this capability. If only the new thermostat is programmable, you'll need to keep the existing thermostat set several degrees below the lowest programmed temperature setting of the new thermostat. NOTE: In this configuration, if the HF60 cannot maintain the desired thermostat setting, the room will be allowed to cool to the lower set point of the existing thermostat before allowing the heat pump to operate.

Special note: Even if the heat pump has a multi-stage thermostat, it cannot be re-wired to make the first stage control the HF60, and the second stage control the heat pump. All multi-stage heat pump thermostats are interconnected so that the compressor unit and/or the changeover solenoid activate with the first stage only.

### Controlling the existing furnace fan during overheat situation.

Following the wiring diagram on the next page, you will need to supply and install a piece of 18/3 Thermostat wire between the low-voltage control terminal strip on the upper left-hand side of the HF60's control cover, to the low-voltage control of the existing furnace.

**Note: Some systems may have external terminals and some may have them enclosed within the unit. If the connections to the existing system need to be made internally, be sure to use the proper protective grommet or connector where passing through the cabinet of the existing unit.**

If the wiring used does not match the colorings listed, follow the corresponding numbers on the terminal strips to ensure proper connection.

Step 1. Disconnect electrical power to the existing heating system.

Step 2. Install the above mentioned thermostat wire between the two systems

Step 3. Connect the three (3) wires to the HF60 control terminal strip as indicated.

Step 4. Remove the green wire which comes from the existing thermostat and connects to the terminal marked "G" on the existing system and splice it to the green (or #1) wire from the HF60.

Step 5. Connect the white wire (or #5) from the HF60 to the "G" terminal of the existing system. This white wire should be the only wire connected to "G".

Step 6. Now, the red (#3) wire from the HF60 should be added to the "R" terminal of the existing system. Do not remove or replace any existing wires from "R", just add this one to them.

Restore power to the existing system only. Using the existing thermostat, increase the setting to verify that the system works as it did prior to the interconnection. Increase and decrease the thermostat a few times to verify proper reaction. In the case of a heat pump system, be sure the outdoor compressor unit is also cycling. Notice: Most compressors have a built in lockout timer (usually 5 minutes) so you may need to wait between thermostat adjustments to verify proper operation.

Once you are certain that nothing changed with the operation of the existing system, turn the existing system's thermostat down far enough that it won't come on during the test. Connect power to the HF60, and turn on the circuit breaker on the front of the unit. With the control in the "OFF" position, turn the feed adjuster knob to "Test". When the OVERHEAT SAFETY ZONE light illuminates, the fan on the existing system should come on. Be sure that the fan is the only thing on. There should be no power to the compressor or the oil or gas burner.

# Installation With A Hot Air System

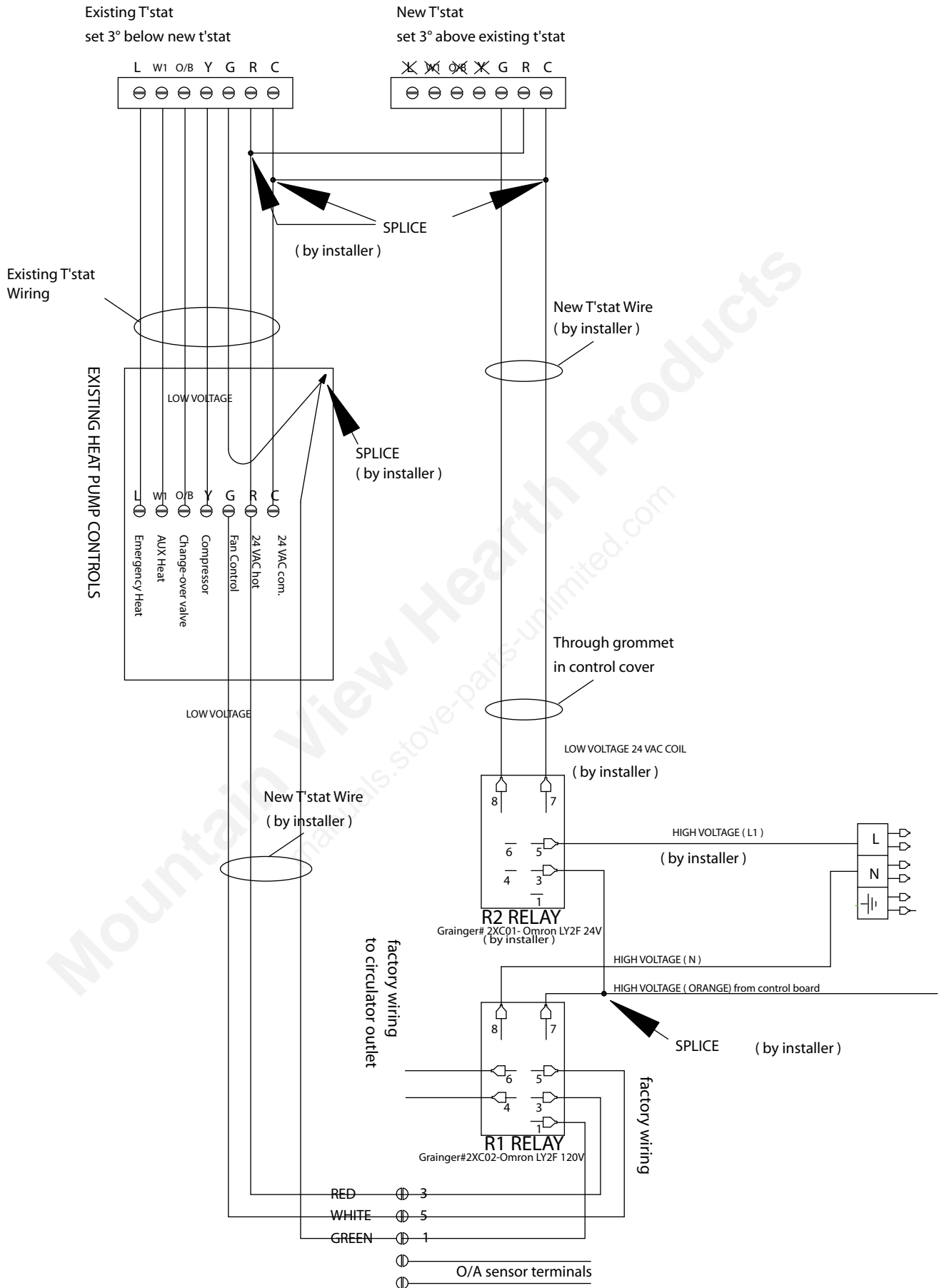

# Installation With A Hot Air System - fan only capable

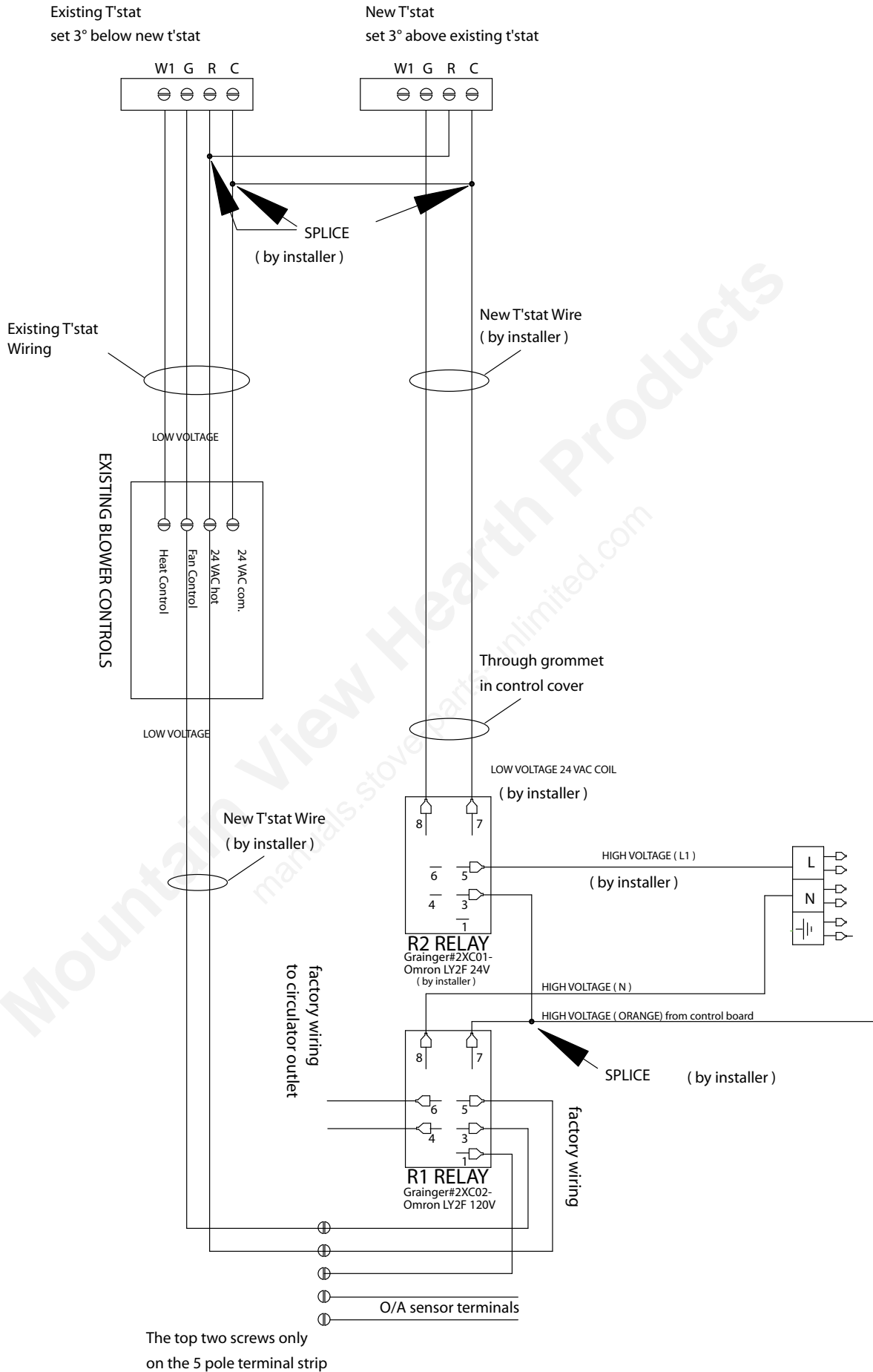



# Connection with a wireless thermostat

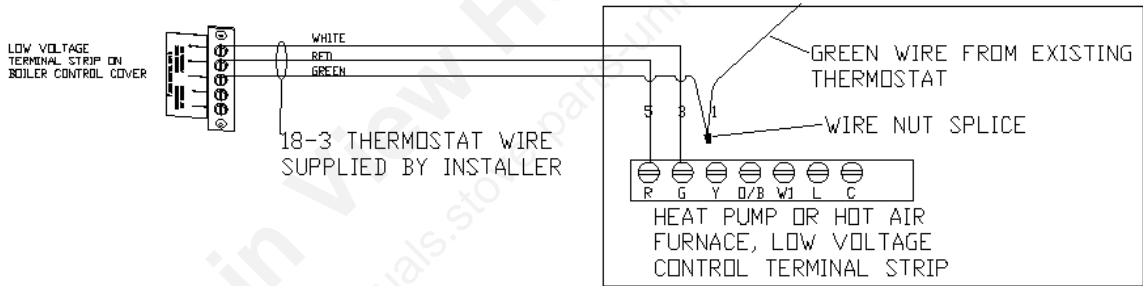
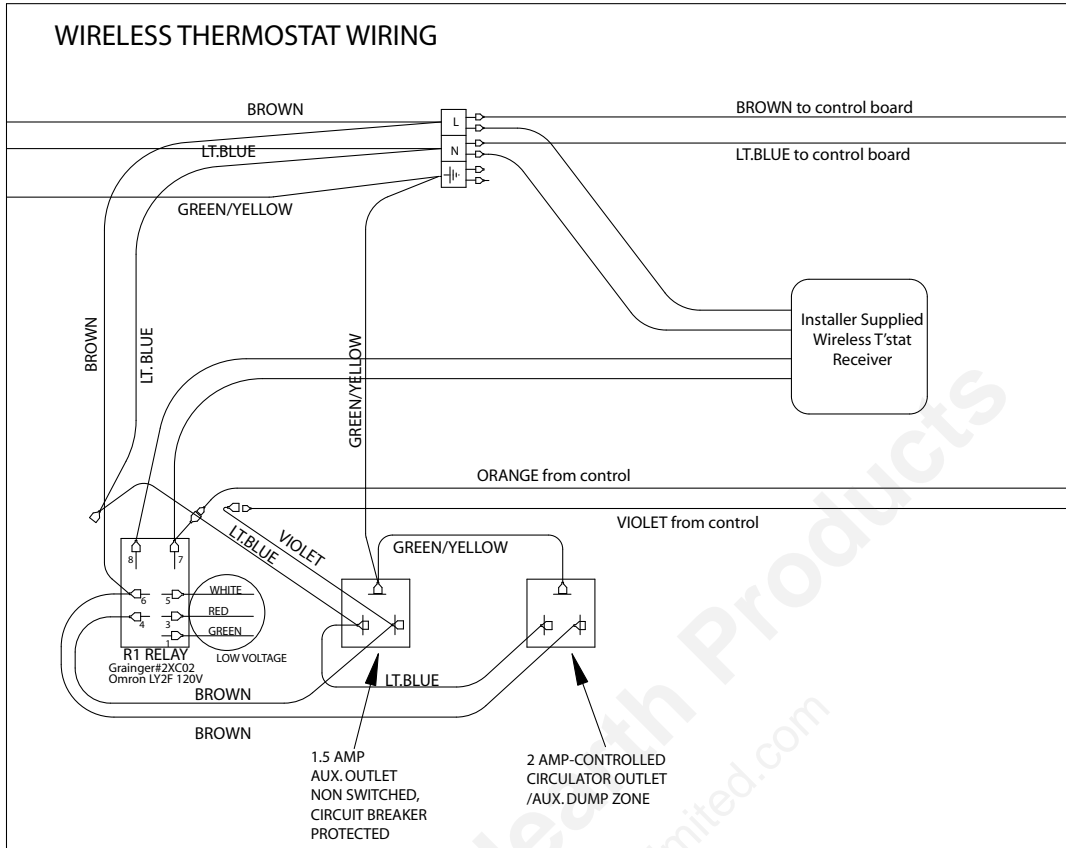

EXTERNAL WIRING FOR UNITS WITH 4 POLE TERMINAL STRIP  
WHEN USING AN RC T'STAT or OTHER DUAL T'STATS

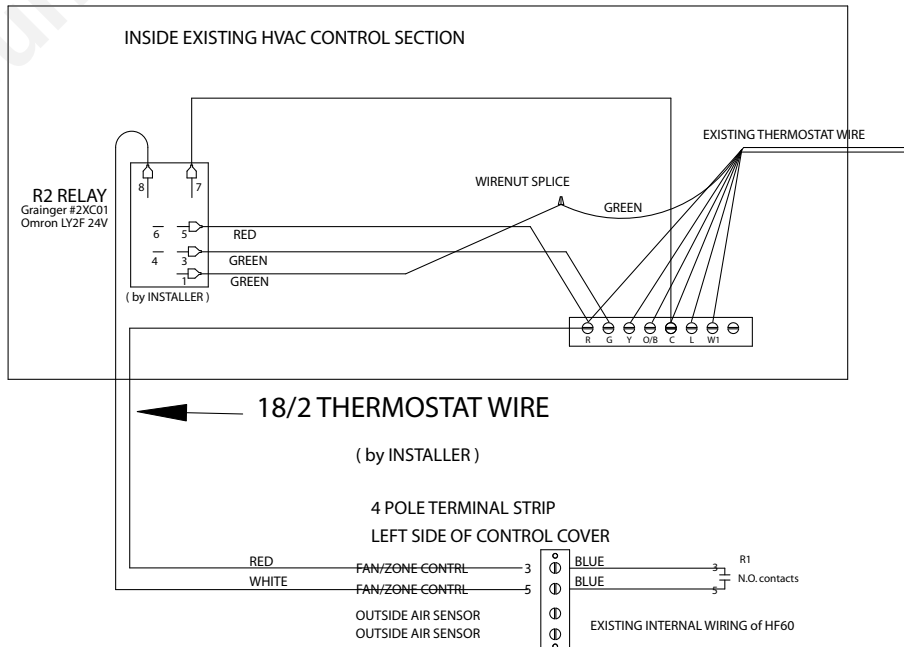

# Installation

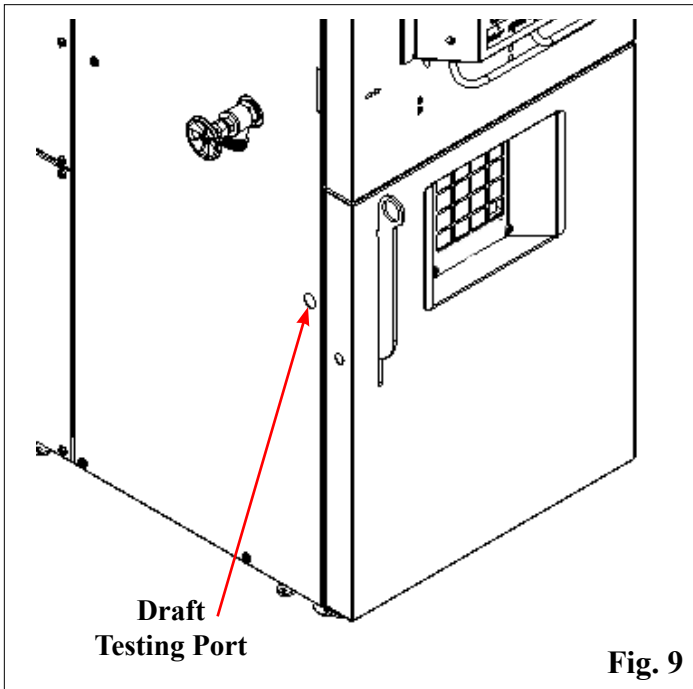

Fig. 9

## Draft Test Procedure

After the venting is completed, the firebox draft will need to be checked and possibly adjusted. After removing the plug bolt from the draft hole (3/16" hex key wrench) shown in Fig. 9, insert the draft meter tube. The hopper lid must be latched during this test. (It is recommended that the draft meter have a scale of 0 to 1" WC.)

Turn the feed adjuster to "Test". This will start the combustion blower and allow you to check and record the High Draft \_\_\_\_\_ - IWC date \_\_\_\_\_. The maximum draft allowed is -.9" Water Column (-224 Pa). There is no adjustment for the High Draft, other than re-positioning the combustion blower fan blade on its shaft, or a change in the venting configuration.

After the first 60 seconds the "Test" mode lowers the combustion blower voltage to the Low Burn voltage. During this lowered voltage cycle, the **Low Draft must be checked** and adjusted if necessary. The recommended low draft setting should be between -.45 and -.55 IWC. Depending on the amount of vertical rise, it may not be possible to get a low draft reading in this range. In this case, re-positioning the fan blade further on the motor shaft may be helpful.

There is a low draft voltage adjustment screw located through the small hole to the right of the Igniter Light. See Fig. 10. Adjusted Low Draft is \_\_\_\_\_ -IWC. To increase the draft in higher altitudes, High Altitude kit # 1-00-232059 may be needed.

**Don't forget to turn the feed adjuster off of "Test", and reinstall the draft test plug bolt into the boiler.**

**CAUTION: Hot While In Operation. Do Not Touch. Keep Children, Clothing And Furniture Away. Contact May Cause Skin Burns. See Nameplate And Instructions.**

**WARNING: Keep Doors Closed During Operation.**

**WARNING: Do Not Store Fuel or Other Combustible Material Within Installation Clearance Area.**

**WARNING: Risk of Fire - Do Not Operate With the Flue Draft Exceeding -.9" Water Column (-224 Pa).**

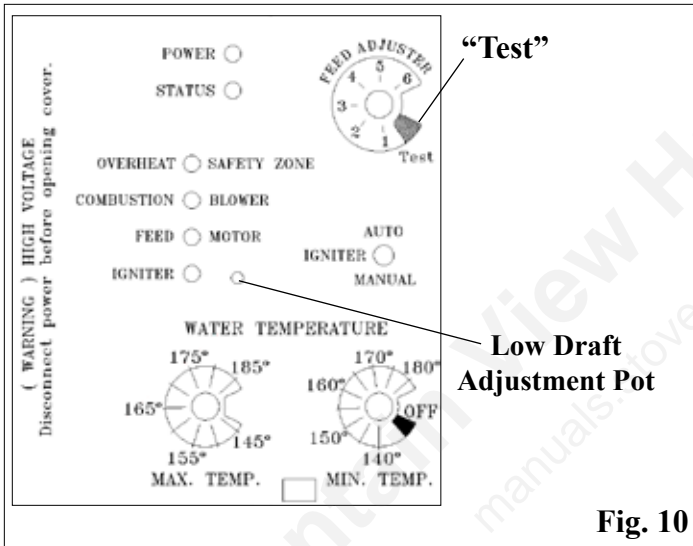
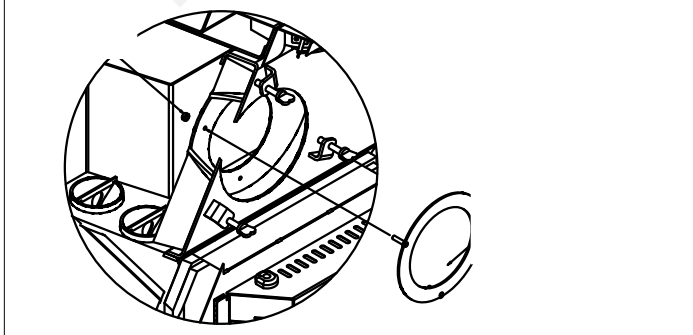

Fig. 10

## High altitude kit #1-00-232059.

Install this ring to increase draft in higher altitude installation locations.



# Operation

## Power Light

Indicates power to the control board. (Ready)

## Status Light

Will be lit anytime the unit is in operation.

## Overheat Safety Zone Light

Indicates that the boiler water temperature has reached 210 Degrees F.

## Combustion Blower Light

Indicates Power to combustion blower

**Feed Motor Light** Indicates Power to the feed motor.

## Igniter Light

Indicates power to the igniter

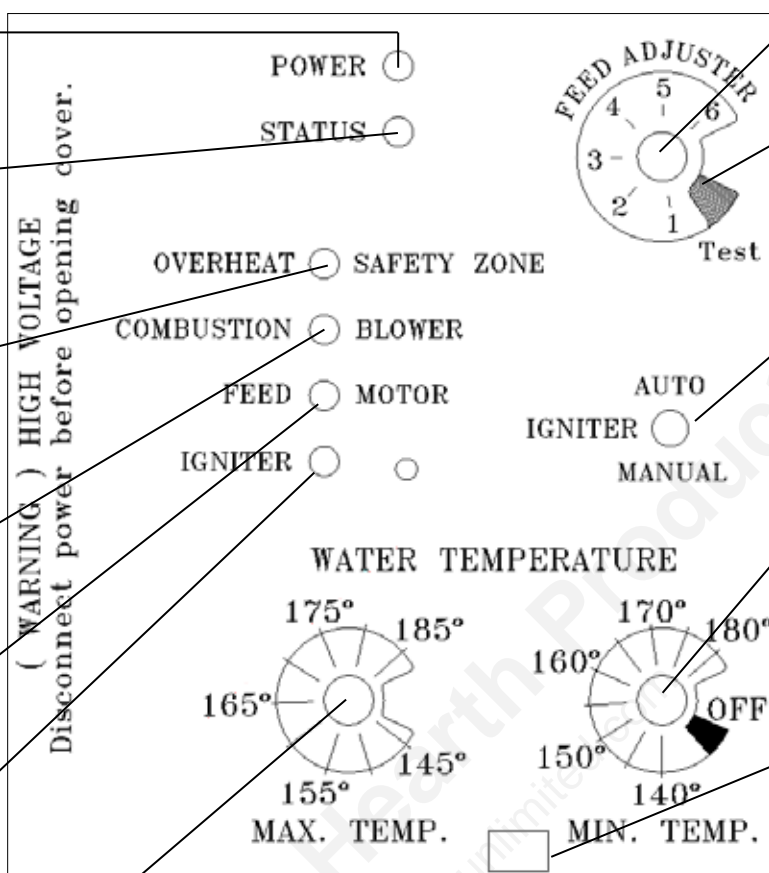

## Feed adjuster

Sets the maximum feed rate

## Test

Combustion blower, feed motor and safety dump zone are fully energized for the first minute. Then, the combustion blower will stay on low.

## Lighting Mode Selector

Switched between Auto and Manual lighting.

## Mode Selector/Min Temp Dial

Used to turn the boiler on or off and set the desired minimum operating temperature of the boiler.

## Diagnostic Port

For maintenance only. Requires special DDM monitor supplied to trained technicians exclusively.

## Max Temp dial

The "Max Temp Dial" is used to set the desired maximum operating temperature of the boiler.

## Status light error messages:

**3 Blinks:** Indicates that the ESP (Exhaust Sensing Probe) has gone out of range too many times. If the unit is operating correctly, perform a manual reset by cycling the main power off at the circuit breaker for a few seconds. If the 3 blinks persist, contact your service technician.

**4 Blinks:** Indicates mis-communication with the aquastat, or the aquastat is not attached properly. May require a manual reset (turn off power at circuit breaker). Note that in some optional control methods, this status will occur during normal operation and reset automatically.

## 5 Blinks: (In Auto Light Mode Only)

Indicates that the igniter has failed to light the fire after 40 Minutes. To reset - Turn the Mode Selector/Min. Temp. to OFF and then back to the desired temperature.

**6 Blinks:** Indicates that the control has calculated poor or incomplete combustion occurring for 25 or more minutes.

A six blink status may occur if the stove is allowed to run out of pellets. To reset, turn Mode Selector/Min Temp dial to "OFF" then back on to the desired temperature. If the unit was not out of pellets, see Troubleshooting section, Page 38, for more details.

**7 Blinks:** Boiler water overheat safety shut down (220 Degrees F.) This requires a manual reset by cycling the main power off for a few seconds and re-connect.

## Explanation and Importance of the OverHeat Safety Zone

When the unit is operating at High burn, and all demand from the heating system stops, the control will reduce the feed rate and shut down completely as necessary. This may take several minutes, and the remaining heat may cause the water temperature to rise to over 210 degrees F. When this happens, the OVERHEAT SAFETY ZONE light on the control will illuminate and the relay R1 is energized. This will close contacts #5 and #3 (Fan Contacts on the interconnection Page 20), and will also energize the controlled circulator outlet, for the hot water dump zone.

When using a hot water coil in an air duct system, if you do not want the living space heated beyond the thermostat setting during an over heat dump, an alternate dump zone will need to be installed and some internal control re-wiring will be necessary.

Label from unit control panel showing outlets



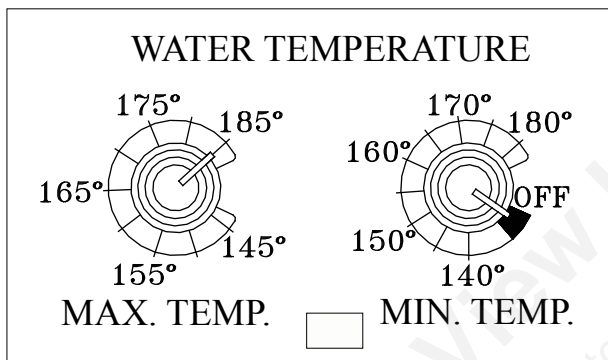
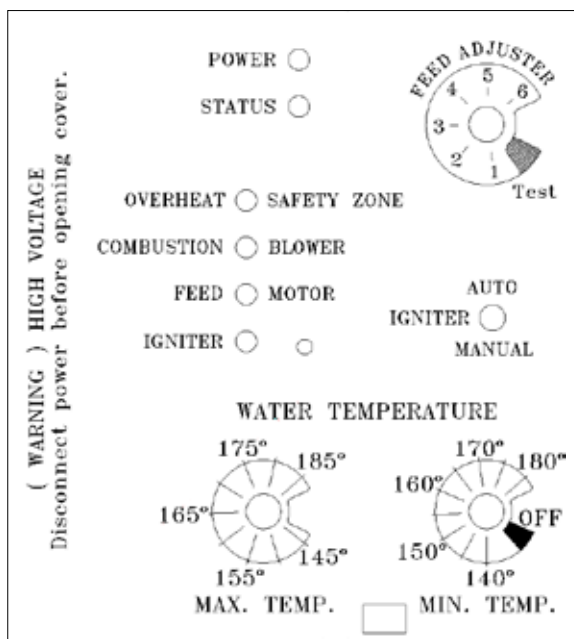

## Setting The Boiler Temperature

### Without the Outdoor Air Temp - Sensor Installed

To set the maximum boiler water temperature, simply turn the Max. Temp. water temperature dial to the desired setting. The control and the boiler will then perform to achieve and maintain the set temperature.

The Min. Temp. Knob is the boiler water temperature minimum, or the lowest temperature the water will go before the unit re-starts. Turning the knob fully counterclockwise is the “OFF” position, while turning the knob fully clockwise, past the 140 degree marking, is the “ON” position.

### With The Outdoor Air Temp - Sensor Installed

Maximum boiler temp setting is as described above, with the added feature of automatic maximum water temp controlled by the OAT sensor.

The MIN. TEMP. knob, in addition to being the mode setting (on or off), also has the function of setting the minimum boiler water temperature. This would be the lowest boiler water temperature that you want to have based on the following factors;

- 1.) Outdoor Air Temperature (OAT)
- 2.) Domestic Hot Water Use
  - a.) Hot Water Coil Option
  - b.) Indirect Hot Water Storage
- 3.) Overall Volume of the Heating System

## Control Board Operation

**Aquastat Sensor** - This sensor is located behind the control panel. This sensor, along with the outdoor air sensor, is what the control board uses to regulate the burn rate based on the observed conditions. (Boiler Temp. & Outdoor Air Temperature)

**Outdoor Air Temp - Sensor (OAT):** This sensor is located outside the building (on the north side of the house and out of direct sunlight). The Outdoor Air Sensor is used to perform hot water reset based on outdoor air temperatures.

When the OAT sensor is installed, at 20° F. or below (outside temperature), the boiler will operate at the temperature set on the MAX. TEMP. knob. The boiler water temperature will decrease by 1 degree F. for every 1 degree F. in temperature rise (above 20°) of the outdoor air.

**NOTE:** Pellet Boiler Outdoor Air Reset Operation Graph located on page 28.

*The boiler is designed to withstand lower return water temperatures. However, extended return temperatures below 140 degrees F can cause condensation.*

### NOTE:

*If the system is run at the lower temperature settings, conditions of the firebox, boiler tubes, secondary ash chamber and venting should be monitored closely. If any indications show excess condensation, the boiler water temperature will need to be increased until condensation does not occur.*

## Pellet Boiler Outdoor Air Reset Operation

When the outdoor sensor is installed, at 20° F. or below OAT (Outdoor Air Temperature), the boiler will operate at the temperature set on the Maximum Temperature knob. The boiler water temperature will decrease by 1 degree for every 1 degree in temperature rise of the Outside Air.

### WATER TEMPERATURE

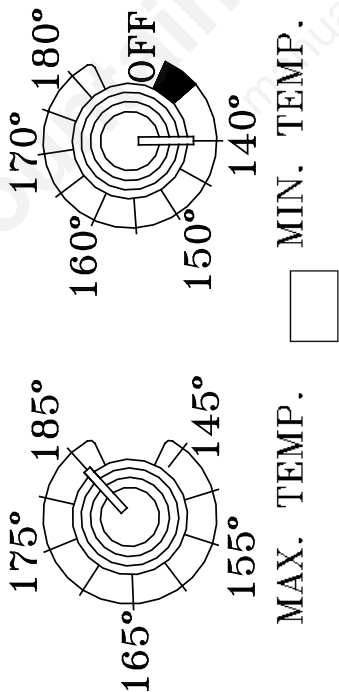

**Example 1**

	OAT	Water Temp	Degree Change
Max set at 185°	65°	140°	-45°
Min set at 140°	60°	145°	-40°
	55°	150°	-35°
	50°	155°	-30°
	45°	160°	-25°
	40°	165°	-20°
	35°	170°	-15°
	30°	175°	-10°
	25°	180°	-5°
	20°	185°	0°
	15°	185°	0°
	10°	185°	0°
	5°	185°	0°
	0°	185°	0°

### WATER TEMPERATURE

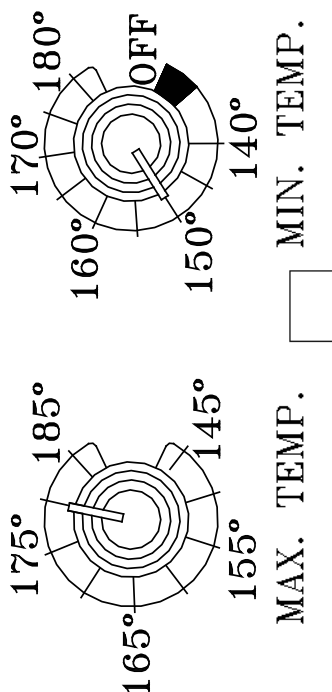

**Example 2**

	OAT	Water Temp	Degree Change
Max set at 180°	65°	150°	*
Min set at 150°	60°	150°	*
	55°	150°	*
	50°	150°	-30°
	45°	155°	-25°
	40°	160°	-20°
	35°	165°	-15°
	30°	170°	-10°
	25°	175°	-5°
	20°	180°	0°
	15°	180°	0°
	10°	180°	0°
	5°	180°	0°
	0°	180°	0°

\* No change in boiler temperature after reaching minimum setpoint temperature.

# Operation

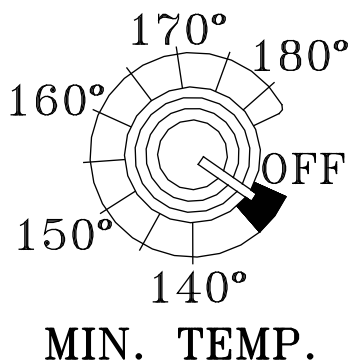

## Starting A Fire Automatically

### 1. Turn Mode Selector to “OFF”.

This resets the control in addition to turning it off.

### 2. Clean Burnpot with scraper.

This is typically a weekly maintenance procedure, but, depending on the fuel being burned, may need done more frequently. Cleaning the burn pot with the scraper with a small amount of new fuel in the bottom is not a problem. First, scrape the ashes from the front of the burn pot into the ash pan. Then scrape the hole grid surface downward into the burn pot. When the stove is ignited these scrapings will be pushed out by the feeder.

**CAUTION: Wear Heat-Resistant Gloves To Perform The Scraping Procedure.**

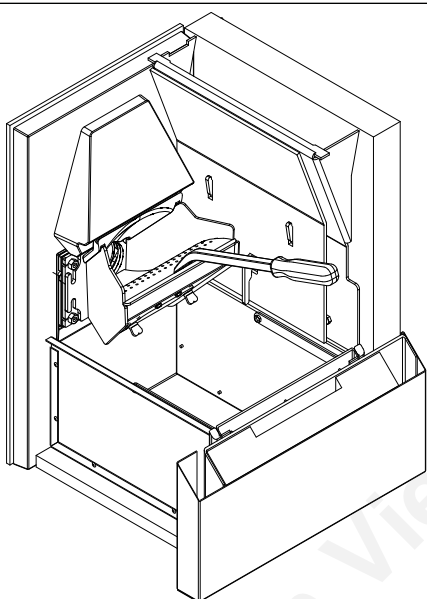

Access the burnpot through the firebox door. Scraping can be done while the unit is in operation. \*see caution

### 3. Fill Hopper with pellets.

Before refilling the hopper, check for excessive fines in the bottom of the hopper. Fines are small pieces of broken pellets (sawdust). Fines do not flow easily and often build up on the hopper funnel bottom angles. These fines can be pushed into the feeder opening and then fill the hopper with pellets. As the system works, they will be burned.

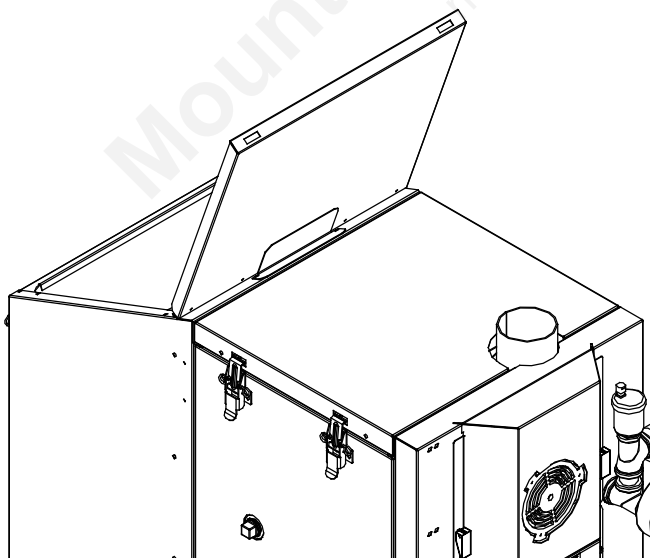

# Operation

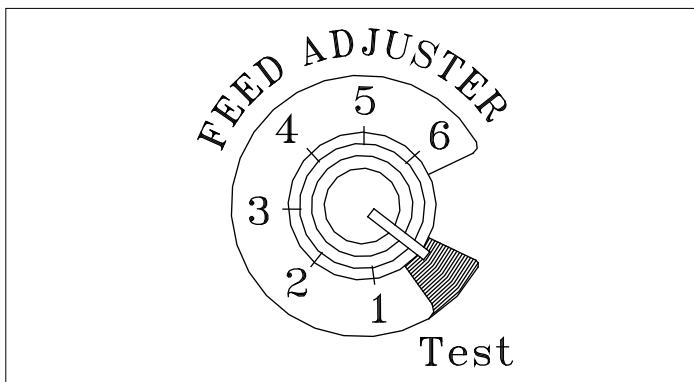

4. **If Starting After an Empty Hopper, Turn Feed Adjuster to “TEST”** (for one 60 second cycle). This will charge pellets into the auger tube and also allow you to check the motors for operation. **NOTE: The auger motor will not operate with any of the doors or hopper lid open.**

5. **Turn Feed Adjuster to #5.**

If this is your first fire or you are trying a new fuel, set the feed adjuster to #5. This setting works well with the average wood pellets, but may need adjusted for your particular fuel. After you know a feed rate setting that works well for your application, stick with that setting. **NOTE:** You know your feed rate is too high when: The overheat safety feature is energized each time the heating zone demand turns off during a high burn. OR, If unburned or partially burned pellets are found in the ash pan. (this may also indicate a need for scraping the burn pot)

*If you need to keep the feed adjuster on it's maximum setting, your unit is under-sized for the heating system. Continuous operation at maximum burn rate may cause pre-mature failure of the firebox baffles.*

**Note: The firebox baffles (#1-10-232052) are considered to be a consumable item, and are therefore not covered by the product warranty.**

6. **Flip the Igniter Switch up** into the “AUTO” position.

**Due to low water temperature, the initial start will be a longer process than when the water temperature is closer to the minimum setting.**

7. **Turn the MAX. TEMP. Dial** on the control board to the desired temperature. This setting must always be at least 5° F. higher than the MIN. TEMP. setting.

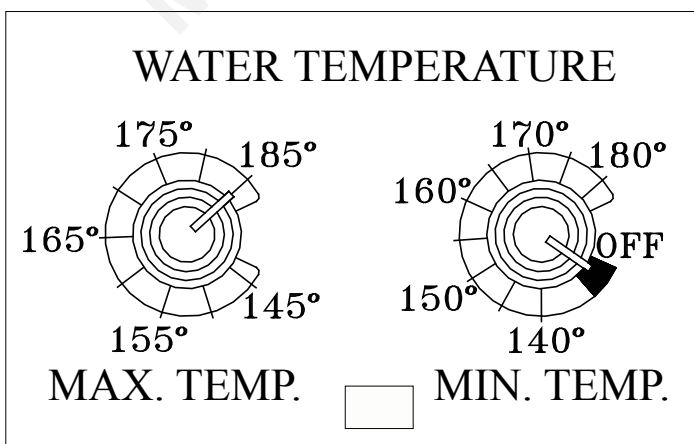
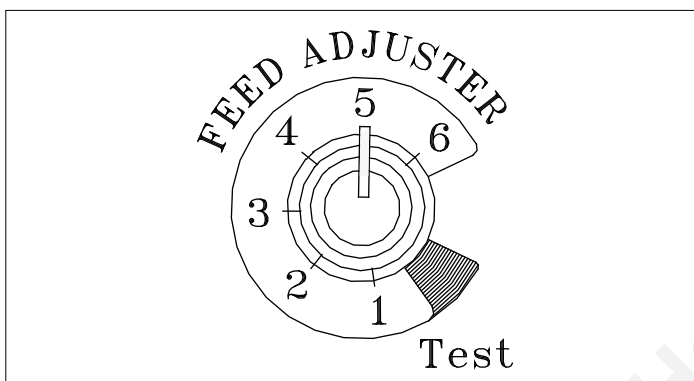

**WARNING: HOT WHILE IN OPERATION. DO NOT TOUCH. KEEP CHILDREN, CLOTHING, AND FURNITURE AWAY. CONTACT MAY CAUSE SKIN BURNS.**

# Operation

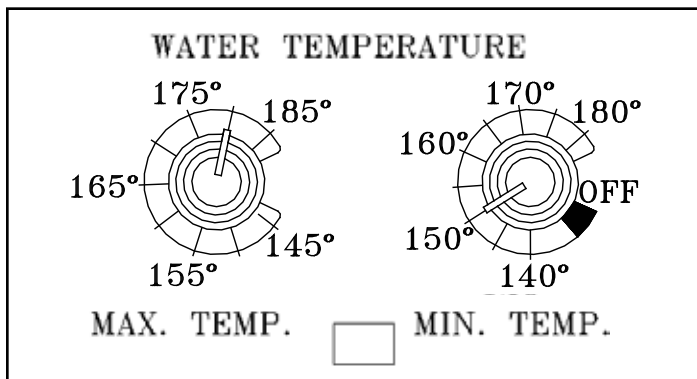

8. Turn the **MIN. TEMP. Dial** on the control board to the desired Minimum temperature. This will start the lighting process if the temperature at the aquastat sensor is approximately 5° F. less than the set temperature on the **MAX TEMP.** dial.

9. Fill **hopper** with pellets and **remove ashes** as required.

## Type of Fuel

Use pelletized wood only. The lower the ash content of the pellets the less cleaning that will be needed of the heat exchanger tubes. The cleaner these tubes are kept, the more efficient the boiler will be.

**NOTE: Do not burn garbage, gasoline, naphtha, engine oil, or other inappropriate materials in this appliance.**

Store pellets in the manufacturer's wrapping until needed to prevent pellets from absorbing moisture. Do not store fuel within the appliance installation clearances, or within the space required for fueling, ash removal, and other routine maintenance operations.

**Never attempt to start a fire if there is no power or if the combustion blower is not operating.**

**Never open the hopper lid during a fire if there is no power or if the combustion blower is not operating.**

## Lighting A Fire Manually

Lighting the fire manually will not be necessary unless the ignition system fails.

Follow steps 1 through 5 of the instructions for automatic lighting.

6. Flip the **Igniter Switch Down** into the "MANUAL-LIGHT" position. See Fig. 12.



Fig. 12

7. Open the firebox door to access the burnpot.

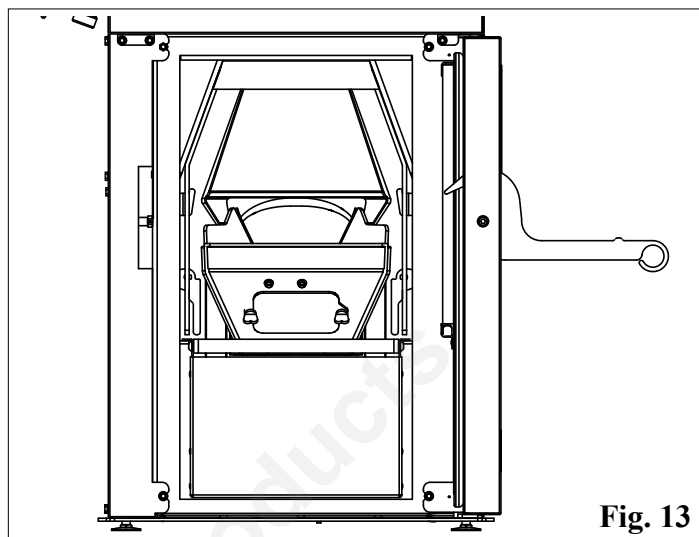

Fig. 13

8. Fill the burnpot with pellets as shown. See Fig. 14. Only fill level with the front edge. (----- **DO NOT OVERFILL** -----)

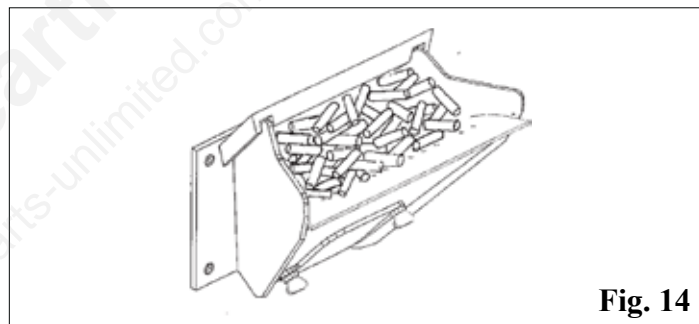

Fig. 14

9. Have matches or other ignition source ready.

10. Turn **Mode Selector** to desired **MIN TEMP** setting.

This will start the combustion blower and allow the ESP to control the fire in relation to the **MAX TEMP Dial** setting. (The **MAX TEMP dial** setting must always be set above the **MIN TEMP** setting) Once the fire is well established the **MAX TEMP dial** can remain on any temperature setting desired.

## DURING MANUAL OPERATION:

**SPECIAL NOTE:** When the **Switch** is set to **Manual ignite position**, the boiler will function as in **auto mode**, except the fire will not be allowed to go out. It will only be allowed to go to a minimum burn rate between the times the aquastat is calling for heat. This rate is about 1.1 pound of fuel per hour. If used in manual mode, be sure there is an **overheat dump in place**. Note that if the **overheat dump zone** does not provide sufficient cooling, and the water temperature reaches 220 deg, the feed motor will be forced to shut off. Because the unit is set on **Manual Ignition**, it will not re-ignite when the water temperature cools below the settings.

# Operation

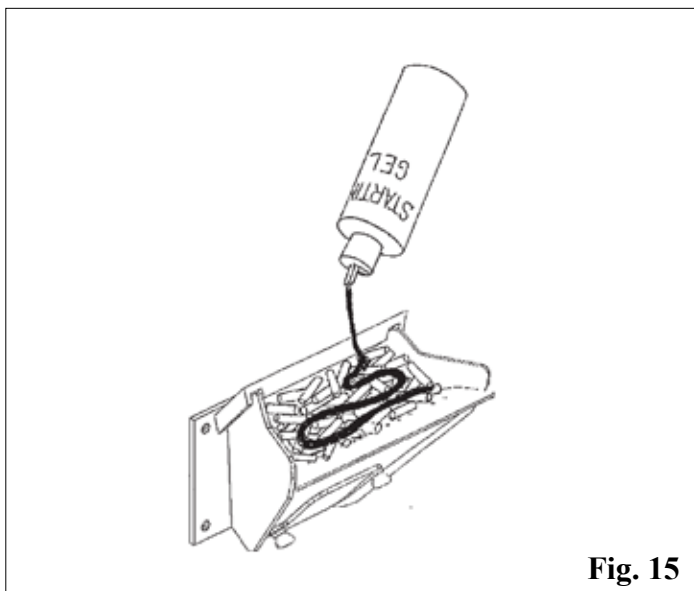

Fig. 15

**NOTE:** Stirring the starting gel into the pellets usually allows the fire to become established quicker.

**CAUTION:** A vapor flash could occur if too much time is allowed to pass before lighting the starting gel.

**CAUTION:** Care must be taken not to get starting gel on your hands or clothing. Serious burns could occur during the lighting process.

**CAUTION:** Never try to apply more starting gel to an already burning fire, or a fire with smoldering pellets.

**“NEVER USE GASOLINE, GASOLINE-TYPE LANTERN FUEL, KEROSENE, CHARCOAL LIGHTER FLUID, OR SIMILAR LIQUIDS TO START OR “FRESHEN UP “ A FIRE IN THIS BOILER. KEEP ALL SUCH LIQUIDS WELL AWAY FROM THE UNIT WHILE IN USE”.**

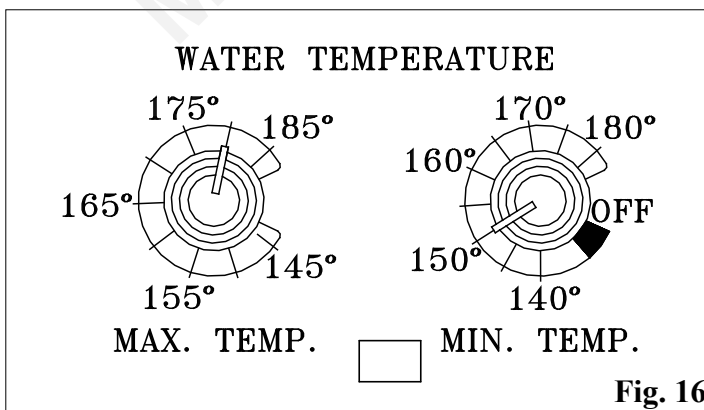

Fig. 16

## 11. Apply starting gel as shown in Fig.15



## 12. Light The Starting Gel With A Match.

## 13. Close The Doors

The fire will light and the control will adjust the rate of burn to the proper level, according to the MAX TEMP dial setting.

**NOTICE: When burning the boiler in the manual ignition mode, there must be an overheat dump zone incorporated into the plumbing system.**

If heating demand stops during manual operation, the control will take the unit to low burn. If no heat is used during this time, the water temperature will continue to rise. When the aquastat senses 220°F, the feeder will be turned off and the fire will go out. This will require a manual re-start of the system. (see page 26 “7 Blinks”)

Solid-fuel burning appliances need to be cleaned frequently because soot, creosote, and ash may accumulate. If you suspect a chimney/vent pipe fire do the following:

1. Call the fire department.
2. Remove fuel from the burn pot using the burnpot scraping tool to scrape the pellets into the ash pan.
3. Remove the ash pan from the unit and take outside. **Do not** place the ash pan on a combustible material.
4. Turn off circuit breaker at unit.
5. Do not use the unit until a qualified person has inspected your appliance and venting.

# Maintenance

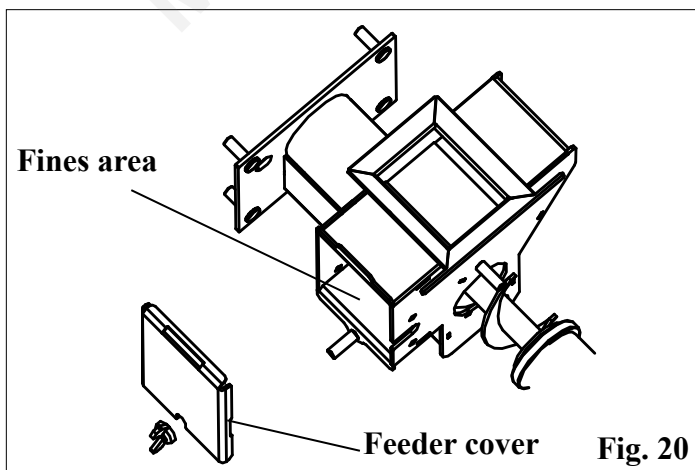
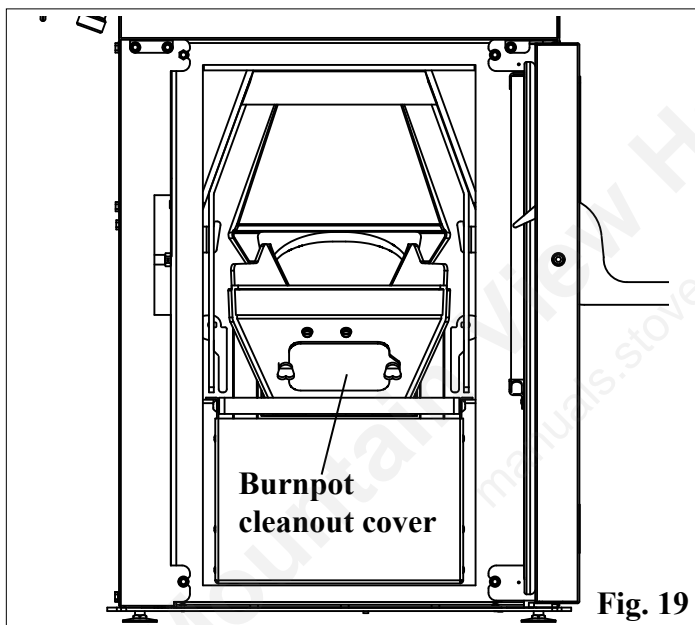
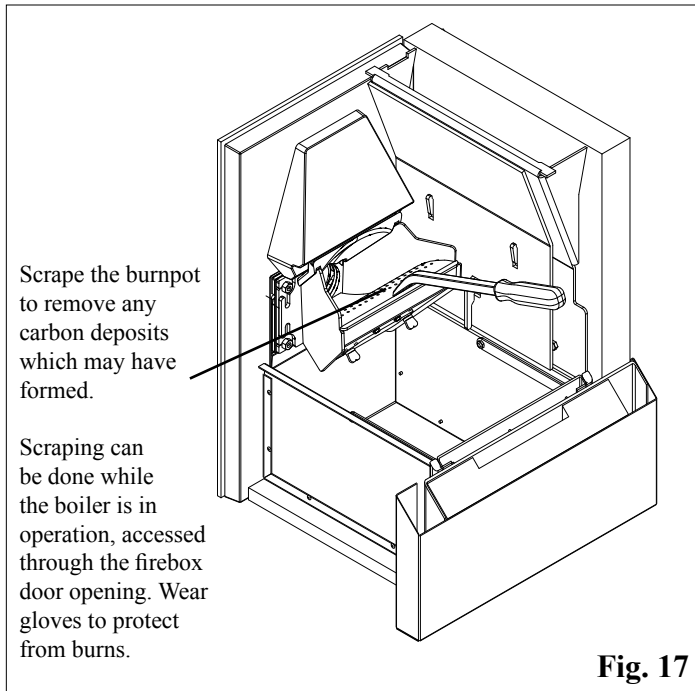

## Burnpot Cleaning:

The burnpot should be cleaned no less than once a week. For best operation the burnpot should be cleaned every time the hopper is filled with pellets. The fire does not have to be out to scrape the burnpot although it is recommended the boiler be on minimum burn at the time of cleaning.

**CAUTION: Wear Gloves To Prevent Burns.**

Use the flat end of the scraper provided to scrape down over the holed surface of the burnpot grate. See Fig. 17. It is not necessary to clean out the scrapings from this cleaning because they will be pushed out as the auger operates.

*Note: Make a special effort to scrape the bottom inside corners of the burnpot where the auger tube enters the burnpot. Carbon deposits can build up over time in this area that may cause a restriction to the flow of pellets into the burnpot.*

*Note: The end of the scraper may need sharpened occasionally, for best results.*

While scraping the burnpot, you can also use the scraper tool to tap on each of the visible heat exchange spirals. This will help to maintain maximum efficiency between cleanings.

## Cleaning the Burnpot Air Chamber:

This area only needs to be cleaned twice a heating season, unless excessive buildup is noticed during scheduled cleanings.

There is a cover on the front of the burnpot to gain access to the air chamber. The cover is held into place by two thumb screws. Loosen the thumb screws and remove the cover. See Fig. 19. The air chamber can be cleaned of any ash that has fallen through the holes during operation and cleaning.

**NOTE: ALWAYS REMEMBER TO CLOSE THE CLEANOUT COVER AFTER CLEANING.**

## Feeder Chamber (Fig. 20):

This chamber may get a buildup of fines from the feeder mechanism movement. This area should be checked and cleaned at least once a year.

### To remove the feeder cover:

- Loosen the 5/16" wing nut.
- Slide the cover off of the threaded stud and lift upward.
- Inspect and clean the inner chamber as necessary. See Fig. 20.
- There is a removable plate in this area that deflects fines into the auger. To remove this plate, roll it out under the pusher arm.
- Reinstall the cover making certain it is centered on the feeder body and hand-tighten the wing nut.

## Inner Refractory Lining

The firebox and heat exchanger tube access areas are lined with high-temperature, fibrous ceramic insulation panels (much like spacecraft tiles). The surface of these panels is hardened to resist normal wear from brushing with a non-metal brush. The panels are not designed to be cleaned with the scraper or other sharp objects. Caution must be taken when cleaning these panels because damage to them is not covered by the warranty. The ash pan slides into the unit on a rail system. This keeps the ash pan from contacting the sides and floor refractory panels. Caution must be taken to ensure there is nothing on the floor surface prior to inserting the ash pan.

## Ash Removal

It is recommended to remove the ashes when the boiler is not in operation. This lessens the chances of coming in contact with hot surfaces. Ashes can be removed while in operation but, extra care must be taken including wearing protective gloves.

## Open The Firebox Door

Swing the latch downward and open the door as shown in fig. 21.

**NOTE:** *Keep hopper lid, and firebox door closed during operation and maintain all seals in good condition. Air leaks will cause low draft conditions, which will result in feeder shutdown.*

## Disposal of Ashes:

Ashes should be placed in a steel container with a tight fitting lid. The closed container of ashes should be moved outdoors immediately and placed on a non-combustible floor or on the ground, well away from all combustible materials, pending final disposal. If ashes are disposed of by burial in soil or otherwise locally dispersed, they should be retained in the closed container until all cinders have thoroughly cooled. Other waste shall not be placed in this container.

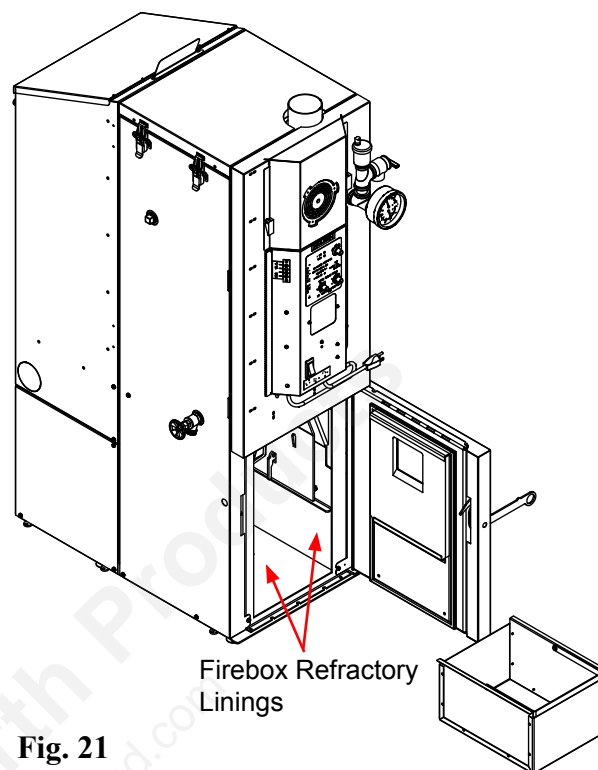
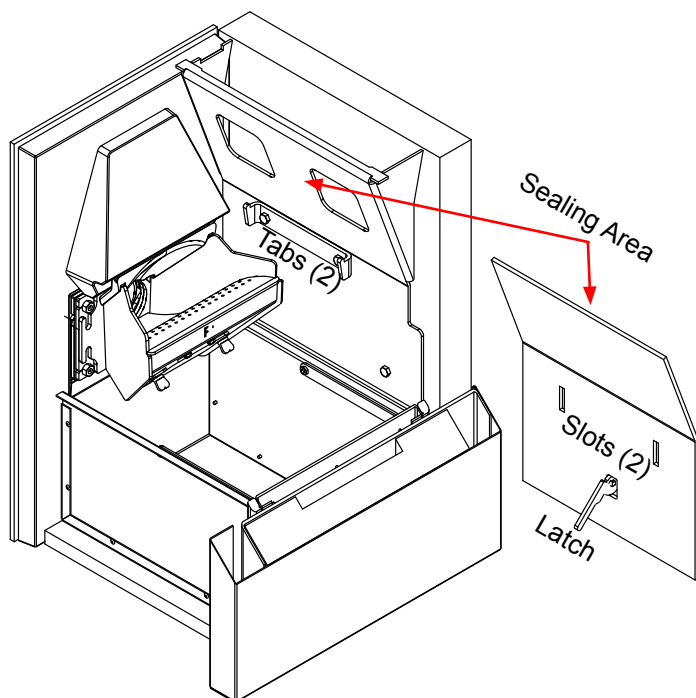

Fig. 21

## Soot and Flyash: Formation and Need for Removal

The products of combustion will contain small particles of flyash. The flyash will collect in the exhaust venting system and restrict the flow of the flue gases. Incomplete combustion, such as occurs during startup, shutdown, or incorrect operation of the boiler will lead to some soot formation which will collect in the exhaust venting system. The exhaust venting system should be inspected at least twice monthly until an appropriate cleaning schedule is determined.

## Firebox Baffle Removal



The tabs go into the slots on the baffle and the latch flips downward to seal at the angle. Lift the latch and lift the baffle off of the tabs for removal. Ashes from the heat exchange tubes can be cleaned from this area. Sliding the firebrick from one side to the other will allow more space for baffle removal.

### Cleaning

To maintain maximum heating efficiency, this cleaning should be performed weekly during the burn season. The frequency of this cleaning will be directly related to the quality and quantity of fuel being consumed. Keep in mind that the cleaner the heat exchanger tubes are kept, the higher the heat transfer efficiency will be.

Due to the ease of restarting, it is recommended that the boiler be turned **OFF** for an hour before cleaning.

Start by removing the two firebox baffles as shown above, then reinstall the ash pan. Next, remove the top heat exchanger cover to expose the heat exchanger tubes. Vacuum this upper exhaust chamber. Some of the tubes contain a spiral baffle which you can use as a cleaning device. Simply work the spiral up and down, approximately 6 inches, to scrape the inside surface of the heat exchange tube(s). The removed debris will fall to the ash pan and on the angled chamber of the firebox. Once all tubes are cleaned, remove the ash pan and clean the remainder from the angles.

With a wisp brush, paint brush or a soot vac, clean the firebox walls and any fly ash that has accumulated in the burnpot, or burnpot opening. At this time you can scrape and clean the burnpot and fines cleanout area.

Spirals can be used to scrape the heat exchange tubes.

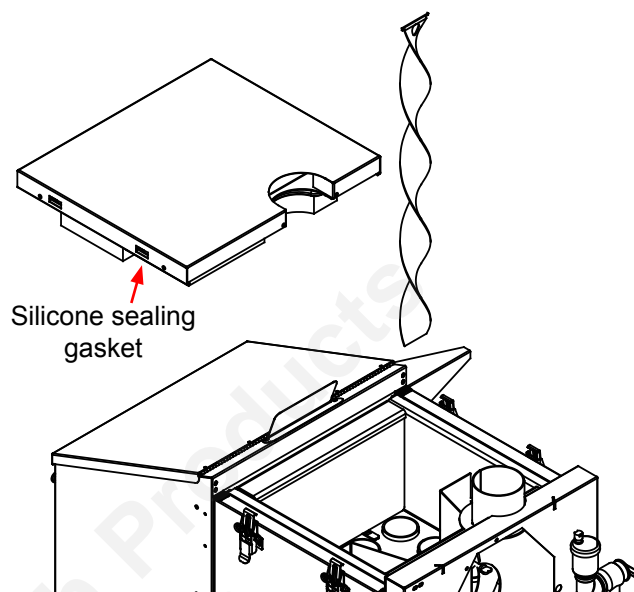

Inspect all sealing gaskets to ensure a proper seal and re-install all components removed for cleaning.

**Note: The firebox baffles(#1-10-232052) are considered to be a consumable item. Check for signs of warping or damage, and replace if necessary.**

**CAUTION: For your safety, do not vacuum hot ashes or embers. Some portions will remain hot, long after shut-down. Wear gloves to protect skin from burns.**

**CAUTION: Cleaning of the heat exchangers, flue pipe, chimney, and combustion blower fan, is especially important at the end of the heating season to minimize corrosion during the summer months, caused by accumulated ash.**

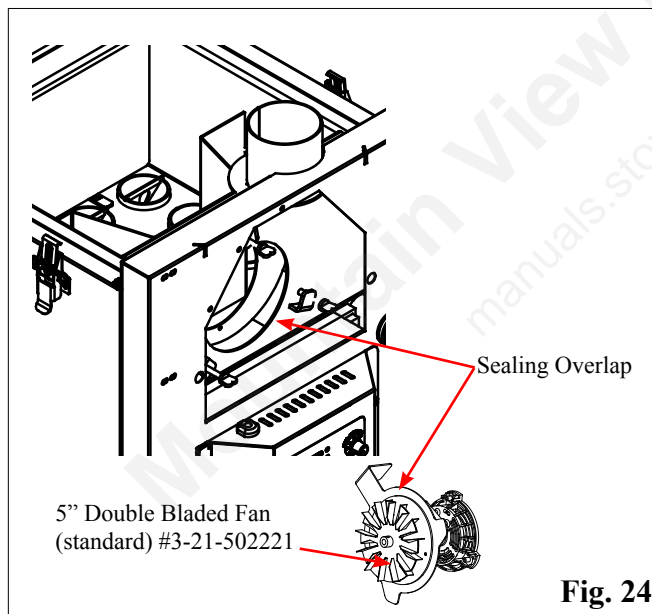
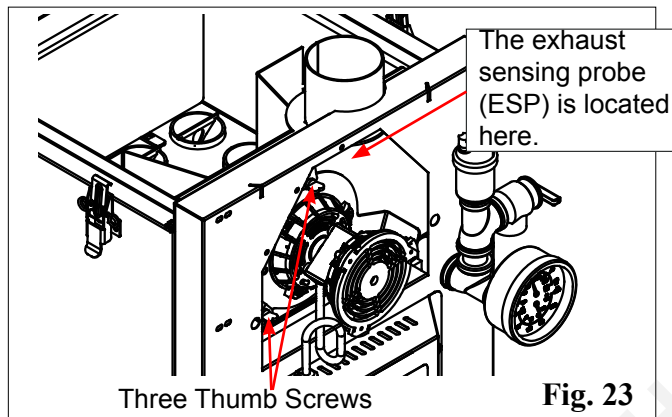
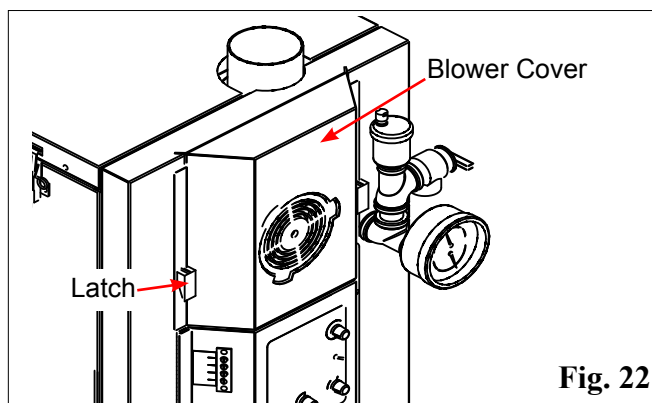

## Combustion Blower Cleaning

Remove the combustion blower cover. There are two latches that hold the shield in place (Fig. 22). Flip the latches up and pull the shield away from the boiler.

The boiler **MUST be OFF at the circuit breaker, and COOL** before you attempt to clean the combustion blower.

The wire to the combustion blower doesn't need to be disconnected during the cleaning process.

Loosen the three (3) thumb screws about 4 turns each. See Fig. 23. Hold the motor head with one hand and the blower plate handle with the other hand. Pull outward on the plate handle until the complete unit comes loose. Now rotate the plate counter-clockwise about 1/8 turn. This will allow the complete assembly to be removed from the blower chamber.

Clean the blower fan blade and the blower plate sealing overlap. See Fig. 24.

**NOTE: Be careful not to bend the fan blade, this will throw the fan blade out of balance or it may rub the inner chamber, which may affect the performance of the boiler. Any horizontal and vertical flue pipe directly above the unit should be cleaned at this time**

**NOTE: The horizontal flue pipe directly above the boiler is the first place fly ash will settle, due to the slowing of flue gas velocity through horizontal pipe. Cleaning of horizontal venting pipes is very important to the efficiency of this boiler.**

**NOTE: The exhaust probe sensing tip extends into this same area. CARE MUST BE TAKEN NOT TO DAMAGE THE ESP DURING CLEANING. Bending of the ESP will make it difficult to remove if it should become necessary. See Fig. 23.**

Clean the boiler blower plate sealing overlap. See Fig 24. Make sure there is no fly ash buildup that may block the easy flow of flue gases into the combustion blower inlet hole. (A flashlight may be necessary.)

**CAUTION: Inspect flue pipes, flue pipe joints and flue pipe seals regularly to ensure that smoke and flue gases are not entering the home.**

# Special Instructions/ Power Failure

Requirements as specified by CAN/CSA- B366.1

**Operation of the HF60 During a Power Failure** - A supply of 120 VAC is required for operation. In the event of a power failure, the unit will not operate. The boiler can be powered alternatively using the Surefire 512 Battery Back-up system, or a generator. The generator must be properly filtered to maintain a constant sine wave of 60 cycle, with a steady 120 Volt output.

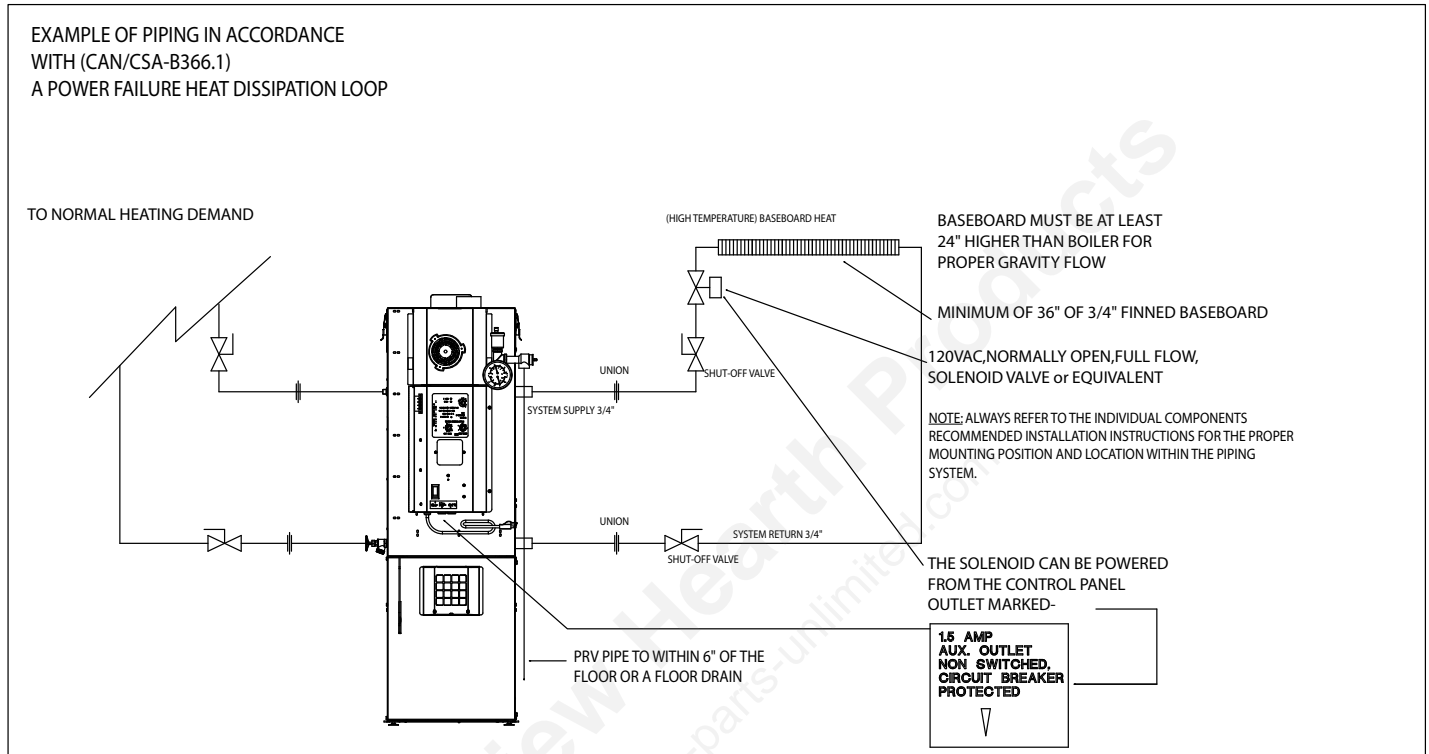

## ASH DOOR GLASS REPLACEMENT

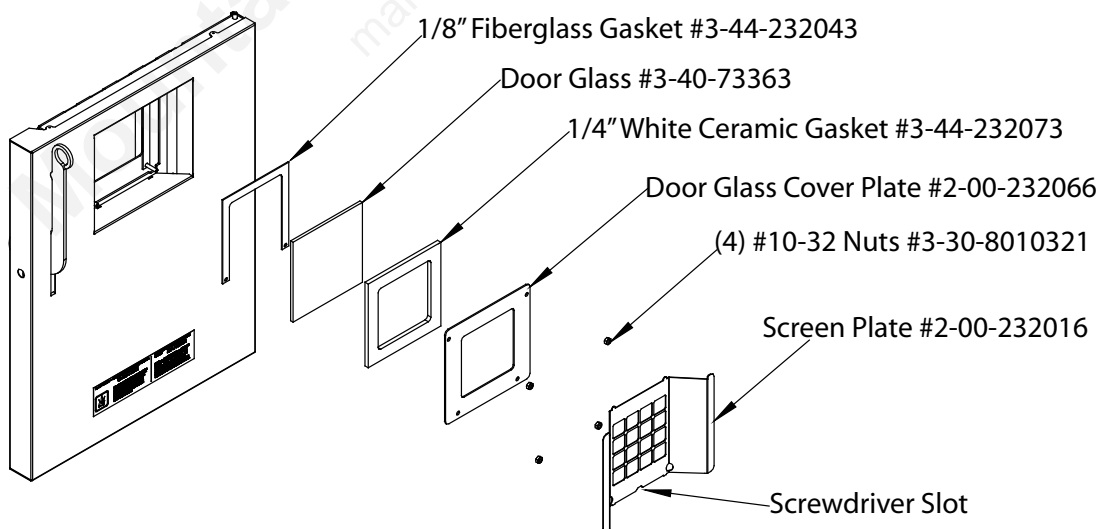

Using a flat screwdriver, pry up and out to remove the screen plate. Remove the (4) 10-32 nuts with a 3/8" wrench or socket. Remove the cover plate, the broken glass, and the gaskets. Install a new 1/8" gasket, a new glass, and a new 1/4" white gasket. Re-install the cover plate. While making sure that everything is centered, tighten the (4) nuts to secure the glass. To install the screen plate, insert it into the slots at the top of the opening, then push in the bottom.

# Troubleshooting

## FEEDER DOES NOT FEED

1. No pellets in hopper.
2. Firebox draft may be too low for low draft pressure switch in feeder circuit to operate. **Check for improperly closed doors**, loose or missing gasket on doors or hopper lid, or a faulty pressure switch.
3. Feed motor will not run until the ESP senses 170 deg. F. Maybe you did not put enough pellets in the burn pot before lighting the fire manually.
4. Something is restricting flow in the hopper or causing the slide plate to stick.
5. Feed motor has failed.

## PARTIALLY BURNED PELLETS

1. Feed rate too high.
2. Draft too low. (Check burn pot clean-out slide and door gasket).
3. Burn pot or heat exchanger tubes may need to be cleaned.
4. Combination of all the above.
5. **#6 status blink:** A 6 blink control board status indication is caused by poor or incomplete combustion. The Automatic Ignition circuit board has the ability to track the combustion through feed settings and ESP temperatures. When the control board has calculated poor or incomplete combustion, it will shut down the unit as a safety feature. (Poor or incomplete combustion is a contributor of creosote which may cause a chimney fire)  
A 6 blink status may be caused by several things:
  1. Blocked or partially blocked flue.
  2. Blocked or partially blocked inlet air.
    - a. Backdraft damper on the inlet pipe may be stuck closed.
    - b. If outside air is installed, the inlet cover may be blocked.
  3. The air chamber under the burnpot may be filled with fines and small bits of ash.
  4. The holes in the burnpot may be getting filled with ash or carbon buildup.
  5. Combustion blower fan may need cleaned.
  6. There is no fuel in the hopper.

## SMOKE SMELL

Seal the vent pipe joints and connection to unit with silicone.

## FIRE HAS GONE OUT

1. No pellets in hopper.
2. Draft setting is too low.
3. Something is restricting fuel flow.
4. Feed motor or combustion blower has failed.
5. Power failure or blown fuse.
6. Firebox door or hopper left open.

## SMOKE IS VISIBLE COMING OUT OF VENT

1. Air-fuel ratio is too rich.
  - A. Feed rate too high.
  - B. Draft too low caused by a gasket leak.

## LOW HEAT OUTPUT

1. Feed rate too low
2. Draft too low because of gasket leak.
3. Poor quality or damp pellets
4. Combination of 1 and 2.

## Helpful Hints

### Cleaning Burn Pot

Whenever your boiler is not burning, take the opportunity to scrape the burn pot to remove carbon buildup. A vacuum cleaner is handy to remove the residue. **Be sure of no hot embers if you use a vacuum.**

Carbon buildup can be scraped loose with the fire burning using the special tool provided with your boiler. Scrape the floor and sides of the burn pot. The carbon will be pushed out by the incoming fuel. Always wear gloves to do this.

### Removing Ashes

Ashes can be removed while in operation, but extra care must be taken and always wear gloves.

Maximum Feed Adjuster settings are not needed in most cases. Operating in the normal range (#4) is recommended when maximum heat output is not required. The ESP prevents the stove from being over-fired.

Keep the boiler free of dust and dirt.

## Fuel

Pellet fuels are put into 3 categories in terms of ash content. Premium at 1% or less, Standard at 3% or less and all others at 3% or more.

The HF60 is capable of burning all 3 categories of pellets, due to a patented feeder and burn pot system.

It should be noted, however, that higher ash content will require more frequent ash removal, scraping of the burn pot, and may provide less BTU's per pound. Normally, standard and high ash pellets cost less than premium pellets and can be cost effective when burned in the HF60.

The moisture content must not exceed 8%. Higher moisture will rob BTU's and may not burn properly.

# Specifications

**BTU Input Range= 0, and 9350 to 60,000\***

0 BTU if system is satisfied.

Min. Burn = 1.1 pound per hour

Max. Burn = 7 pounds per hour

\* 8500 BTU per pound figures

**Electrical 120 VAC 60 Hz**

Combustion blower

1.4 AMP

Auger motor

.7 AMP

Igniter element

2.3 AMP

Control board

.05 AMP

Approximate operating wattage

2 KWH

Shipping Weight (Includes Packaging) 525 Lbs.

**Duty Cycle 80%** - Although this model is rated for 60,000 BTU on high burn, it is not intended to remain on high burn continuously.

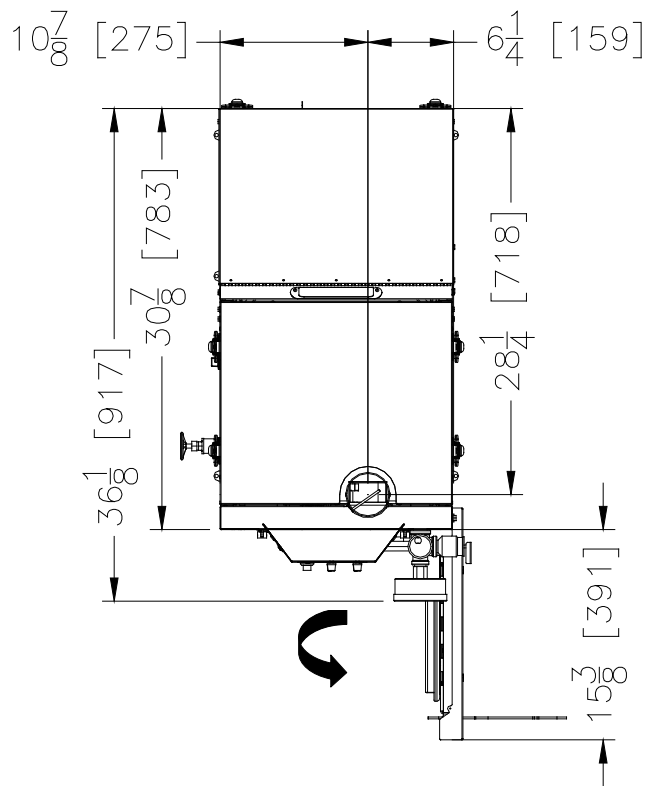
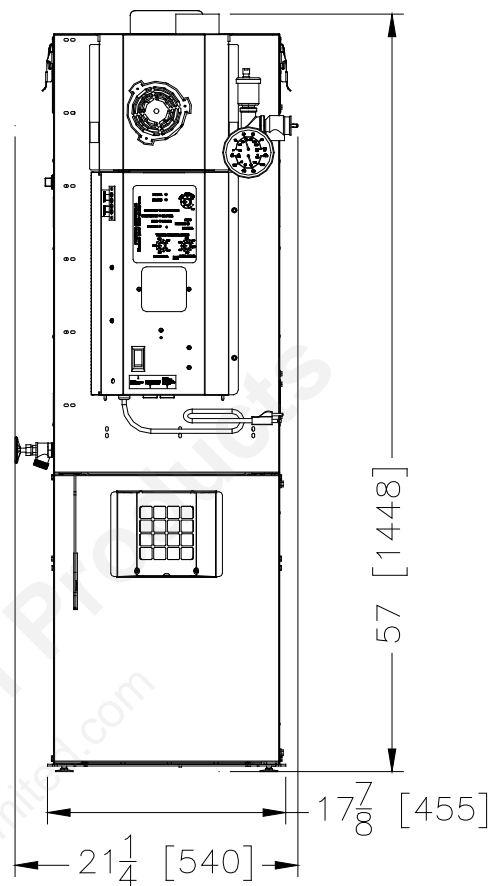
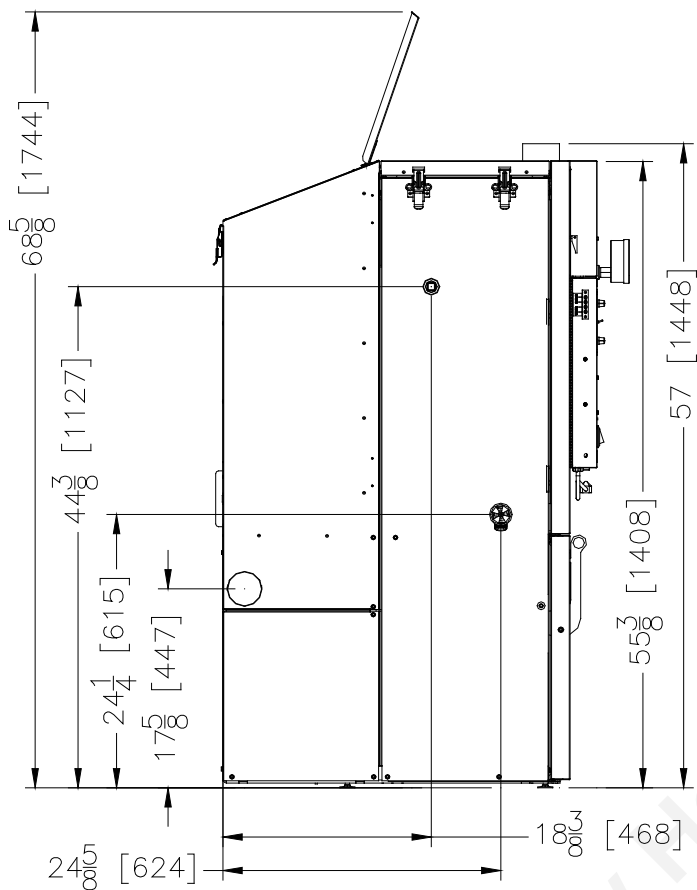

# Wiring Diagram

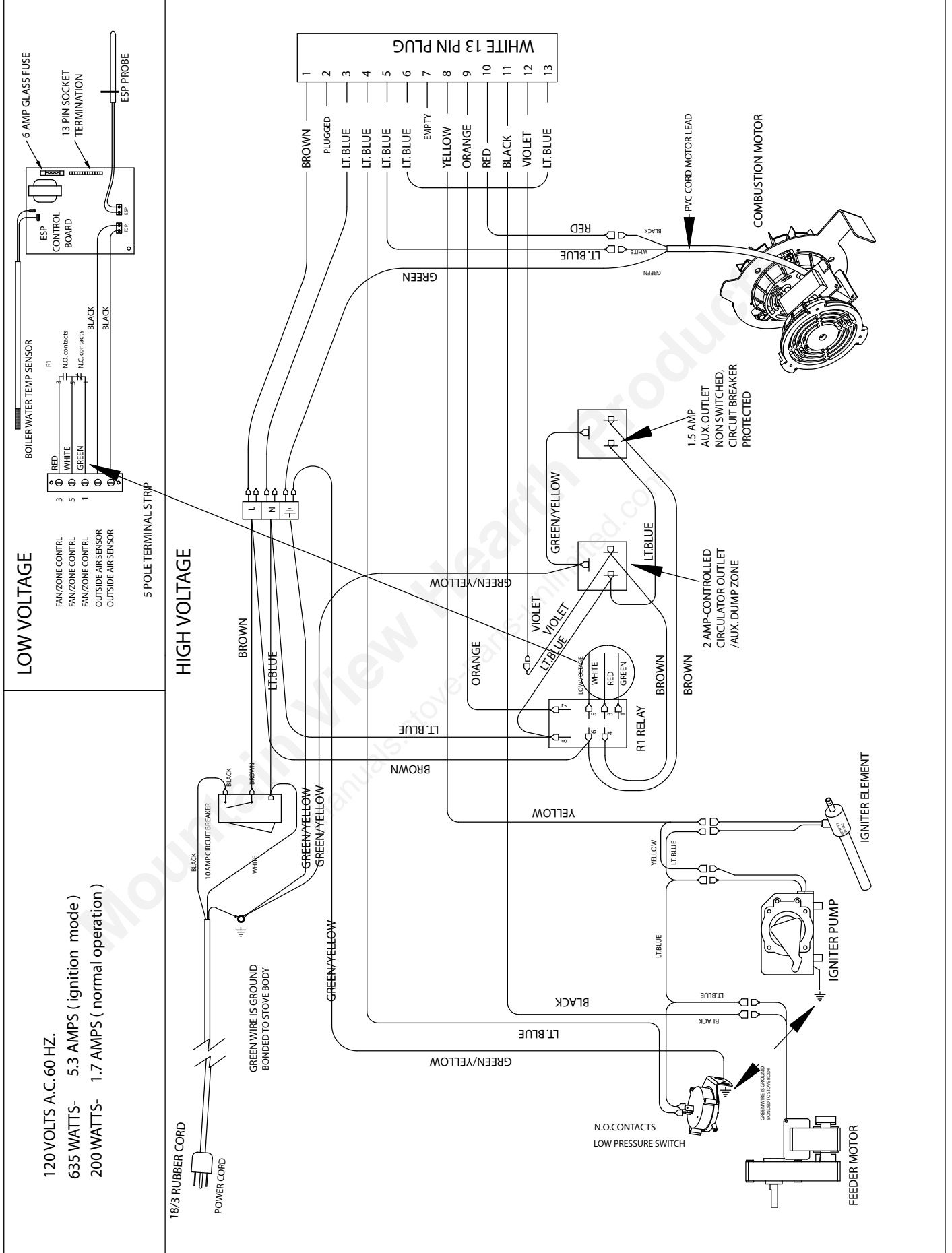

# Warranty

## HARMAN™ CENTRAL HEATING PRODUCTS LIMITED WARRANTY

Hearth & Home Technologies Inc., on behalf of its Harman™ brand ("HHT"), extends the following warranty for all Harman™ furnace and boiler products ("Products") that are purchased from an HHT authorized dealer.

**Warranty Coverage:** Subject to the conditions, exclusions and limitations set forth below, HHT warrants to the original owner of the Products, and to any transferee taking ownership of the Products at the site of original installation within two years following the date of original purchase, that the Products will operate free from defects in material and workmanship under normal conditions and use, as described in the operating instructions furnished with the Product, during the warranty period described below. HHT will, at its option, repair or replace any Product covered by this warranty that is determined to be defective in material or workmanship.

**Warranty Period:** The warranty period runs for six years, except for mechanical and electrical components, which are warranted for three years. The warranty period begins on the earlier of: (i) the date of invoice for the Product; (ii) in the case of new home construction, the date of first occupancy of the residence or six months after the date of sale of the Product by an HHT authorized dealer, whichever occurs first; or (iii) the date 24 months following the date of Product shipment from HHT, regardless of the invoice or occupancy date.

**Warranty Conditions:** This warranty applies only to Products: (i) installed, operated, and maintained as recommended in the Product user's manual; (ii) purchased through an HHT authorized dealer; (iii) while remaining at the site of original installation; and (iv) that have not been altered after leaving the factory.

**How to File a Claim:** Claims must be made within the warranty period to the dealer who sold the Product. If that dealer cannot provide the warranty service, contact the nearest HHT authorized dealer. Additional service fees may apply if you are seeking warranty service from a dealer other than the dealer from whom you originally purchased the Product. Travel and shipping charges for parts are not covered by this warranty.

**Warranty Exclusions:** This warranty does not cover the following: (1) consumable and normal wear items, including, without limitation, flame guides, grates, coal bars, afterburner hoods, fire brick, gaskets, paint, glass discoloration, burnpot housing weldments, burnpot grate weldments (pellet or corn), burnpot front plates (pellet or corn), burnpot front plate locks, corn auger extensions, ceramic inserts, and ceramic insert plates; (2) noise caused by minor expansion, contraction or movement of parts; (3) damage resulting from: (i) failure to install, operate or maintain the Product according to the installation and operating instructions and listing agent identification label furnished with the Product; (ii) failure to install the Product according to local building codes; (iii) shipping or improper handling; (iv) abuse, misuse, continued operation with damaged, corroded or failed components, accident, or incorrectly performed repairs; (v) environmental conditions, inadequate ventilation, negative pressure or drafting caused by tightly sealed construction, insufficient make-up air supply, or handling devices such as exhaust fans or forced air furnaces or other such causes; (vi) use of fuels other than those specified in the operating instructions; (vii) installation or use of components or accessories not supplied with the Product or authorized and approved in writing by HHT; (viii) modification of the product not expressly authorized and approved by HHT in writing; or (ix) interruptions or fluctuations of electrical power supply to the Product; (4) non-HHT components or accessories used in conjunction with the Product; (5) the Products' capability to heat a desired space; information is provided to assist the consumer and the dealer in selecting the proper Product for the application; consideration must be given to Product location and configuration, environmental conditions, insulation and air tightness of the structure; or (6) additional or unusual utility bills incurred due to any malfunction or defect in Products.

**Limitations of Liability:** Repair or replacement in accordance with the provisions of this warranty will be the owner's exclusive remedy for and will constitute HHT's sole obligation under this warranty, under any other warranty (express or implied), or in contract, tort or otherwise. No employee, agent, dealer, or other person is authorized to give any warranty on behalf of HHT. TO THE EXTENT ALLOWED BY LAW, HHT MAKES NO OTHER WARRANTY, EXPRESS OR IMPLIED, INCLUDING ANY WARRANTY OF MERCHANTABILITY OR FITNESS FOR A PARTICULAR PURPOSE. HHT WILL NOT BE LIABLE FOR ANY CONSEQUENTIAL OR INCIDENTAL DAMAGES ARISING OUT OF DEFECTS IN OR USE OF THE PRODUCTS. Some states do not allow exclusions or limitation of incidental or consequential damages, so these limitations may not apply to you. This warranty gives you specific rights; you also may have other rights, which vary from state to state. The duration of any implied warranty is limited to the duration of the warranty period specified herein.

# Testing Label



Tested & Listed By **OMNI-Test Laboratories, Inc.** Portland Oregon USA  
 Report #/Rapport #135-O-20-6,2  
 Certified for U.S.A. and Canada  
 Certifié pour les États-Unis et le Canada

## HydroFlex 60

LISTED PELLET FUEL CENTRAL OR SUPPLEMENTARY FURNACES FOR RESIDENTIAL USE/  
 APPAREIL DE CHAUFFAGE CENTRAL OU SUPPLÉMENTAIRE ENREGISTRÉ DE BOULETTES COMBUSTIBLES POUR USAGE DANS LES RÉSIDENCES



Serial No. **008**  
 N° de série

Tested Oct. 2008 to: CAN/CSA B366.1-M91, UL 391  
 Install and use only in accordance with the manufacturer's installation/operating instructions. Refer to authorities having jurisdiction for proper installation. Contact local building or fire officials about restrictions and installation inspection in your area. If there are no applicable local codes, follow ANSI/NFPA 211 and CAN/CSA B365. Special precautions are required for passing the chimney through a combustible wall or ceiling. Inspect and clean exhaust venting system frequently in accordance with manufacturer's instructions. Use a 3" diameter type "L" or "PL" venting system.

Testé en Oct. 2008 à: CAN/CSA B366.1-M91, UL 391  
 Installez et utilisez en accord avec les instructions du fabricant. Référez-vous à des professionnels du fabricant. Contactez le bureau de la construction ou des restrictions et de l'inspection d'ins. S'il n'y a pas de codes locaux, suivez l'ANSI/NFPA 211 et le CAN/CSA B365. Prenez des précautions spéciales pour passer la cheminée à travers un mur ou un plafond. Inspectez et nettoyez fréquemment le système de ventilation conformément aux instructions du fabricant. Utilisez un système de ventilation de type "L" ou "PL".

Model / Modèle	Fuel / Combustible	Chimney Connector Size / Grandeur du Tuyau de Cheminée	BTUH/Kw Input Pellet / Rendement des Boulettes BTU"	Overcurrent Protection / Section Maximum du Courant
HF60	Wood Pellets / Boulettes	3"	60,000 BTUH (17.6 Kw)	20 AMP

Clearances to Combustibles / Distances aux Combustibles	
Sidewall to Appliance / Mur à l'Appareil	6" (152 mm)
Backwall to Appliance / Arrière à l'Appareil	6" (152 mm)
Combustibles to Pellet Vent / Matériaux Combustibles au Conduit de Fumée	6" (152 mm)
Stove Top to Ceiling / Haut du Poêle au Plafond	6" (152 mm)
Alcove Height / Hauteur de l'Alcôve	829 mm
Alcove Width / Largeur de l'Alcôve	48" (1220 mm)
Alcove Depth / Profondeur de l'Alcôve	60" (1524 mm)
Combustibles from Front of Stove / Des Combustibles au Devant du Poêle	48" (1220 mm)

Flooring / Revêtement de sol: Must be non-combustible and extend 6" to the sides, and 16" (USA) or 18" (Canada) in front of the door. / Le revêtement de sol doit être de l'étendre de matériel incombustible 6" aux côtés, et 16" (USA) ou 18" (Canada) devant la porte d'enlèvement de cendre.

Essential parts and subassemblies provided for field assembly are as follows / Pièces essentielles et sous-assemblées procurées pour l'assemblage sont les suivantes:	
(1) Drain Plug / (1) Boutonnet de Vidange 3/4"	(1) Outdoor Air Sensor / (1) Sonde Extérieure
(1) 1/2" Temperature/Pressure Gauge / (1) Double Indicateur Température/Pression 1/2"	(1) 3/4" Safety Relief Valve / (1) Soupape de Sécurité 3/4"

**DO NOT CONNECT THIS UNIT TO A CHIMNEY FLUE SERVING ANOTHER APPLIANCE**

**NE PAS CONNECTER CET APPAREIL À UN TUYAU DE CHEMINÉE SERVANT UN AUTRE APPAREIL**

**DANGER!** Risk of Fire or Explosion – Do not burn garbage, gasoline, naphtha, engine oil, or other inappropriate materials.

**DANGER!** Risque de feu ou d'explosion. Ne pas brûler des ordures, de l'essence, du pétrole, de l'huile moteur ou autres matériaux inappropriés.

**WARNING: Risk of fire** – Do not operate with the flue draft exceeding -0.9 in Water Column / -224Pa.

**ATTENTION: Risque de feu** – Ne fonctionnez pas avec l'ébauche de conduite de cheminée excédant -0.9" colonne de l'eau / -224Pa.

**WARNING!** Do not operate with fire chamber or ash removal doors open. Do not store fuel or other combustible material within installation clearance area.

**ATTENTION!** Ne pas opérer si la porte du combustible ou la porte de la cuvette des cendres sont ouvertes. Ne pas placer le combustible et les matières combustibles à l'intérieur de l'espace désignée pour l'installation.

**CAUTION!** Hot while in operation. DO NOT touch. Keep children, clothing, furniture and other combustible material out of the installation clearance area.

**ATTENTION!** Chaud lors de l'opération. NE PAS toucher. Gardez les enfants, les vêtements, les meubles et les matériaux combustibles loin de l'espace désignée pour l'installation.

**In the event of loss of electrical power:** Consult owner's manual for restarting your furnace after power is restored.

**Dans le cas d'un manque d'électricité:** Consultez le manuel du propriétaire pour remettre la fournaise en marche lorsque l'électricité est revenue.

Manufactured by/Fabriqué par: **Hearth & Home Technologies**  
 352 Mountain House Road-Halifax, PA 17032

Date of Manufacture/Date de Fabrication														
2009	2010	2011	Jan	Feb	Mar	Apr	May	Jun	Jul	Aug	Sep	Oct	Nov	Dec
■	■	■	■	■	■	■	■	■	■	■	■	■	■	■

Made in U.S.A./Fait aux États-Unis Do Not Remove or Cover This Label/Ne pas enlever ou recouvrir cette étiquette IGN

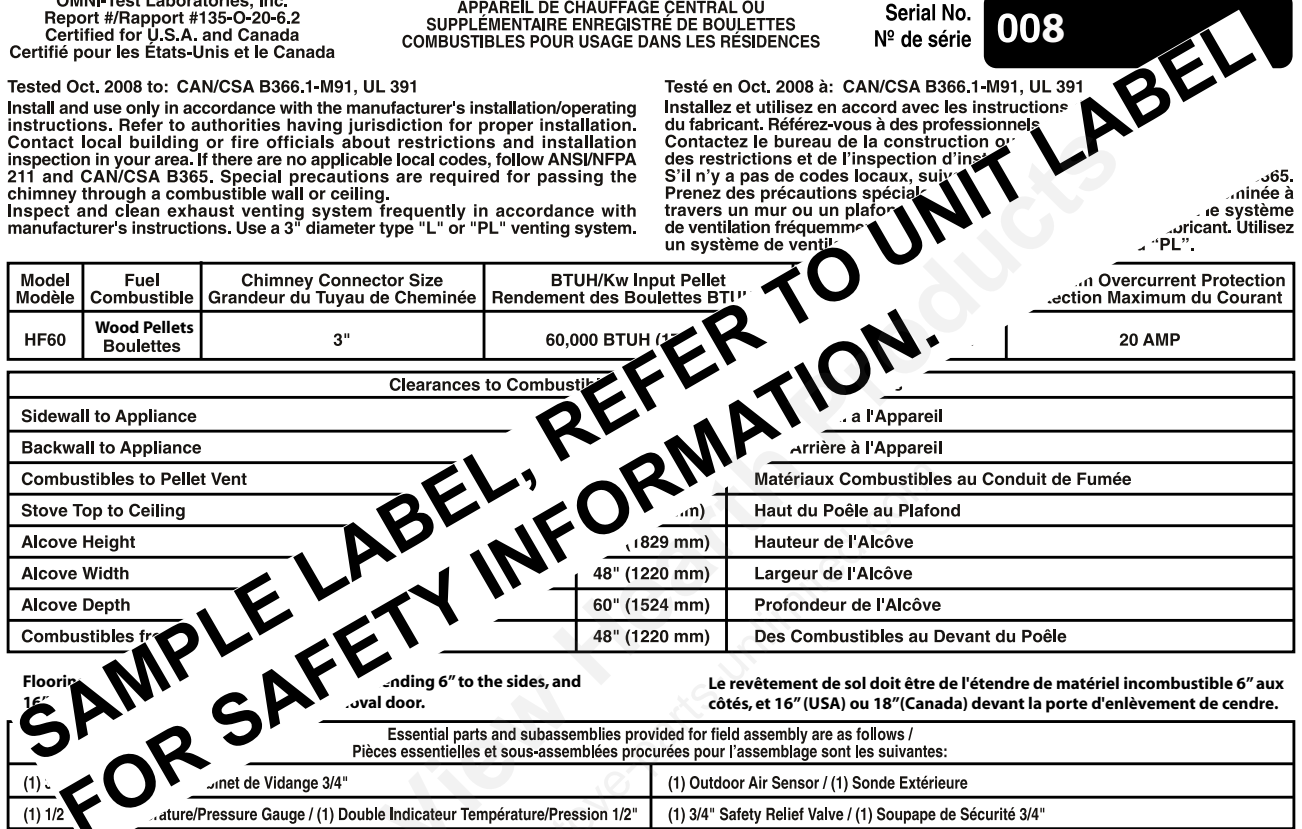

1-90-232000

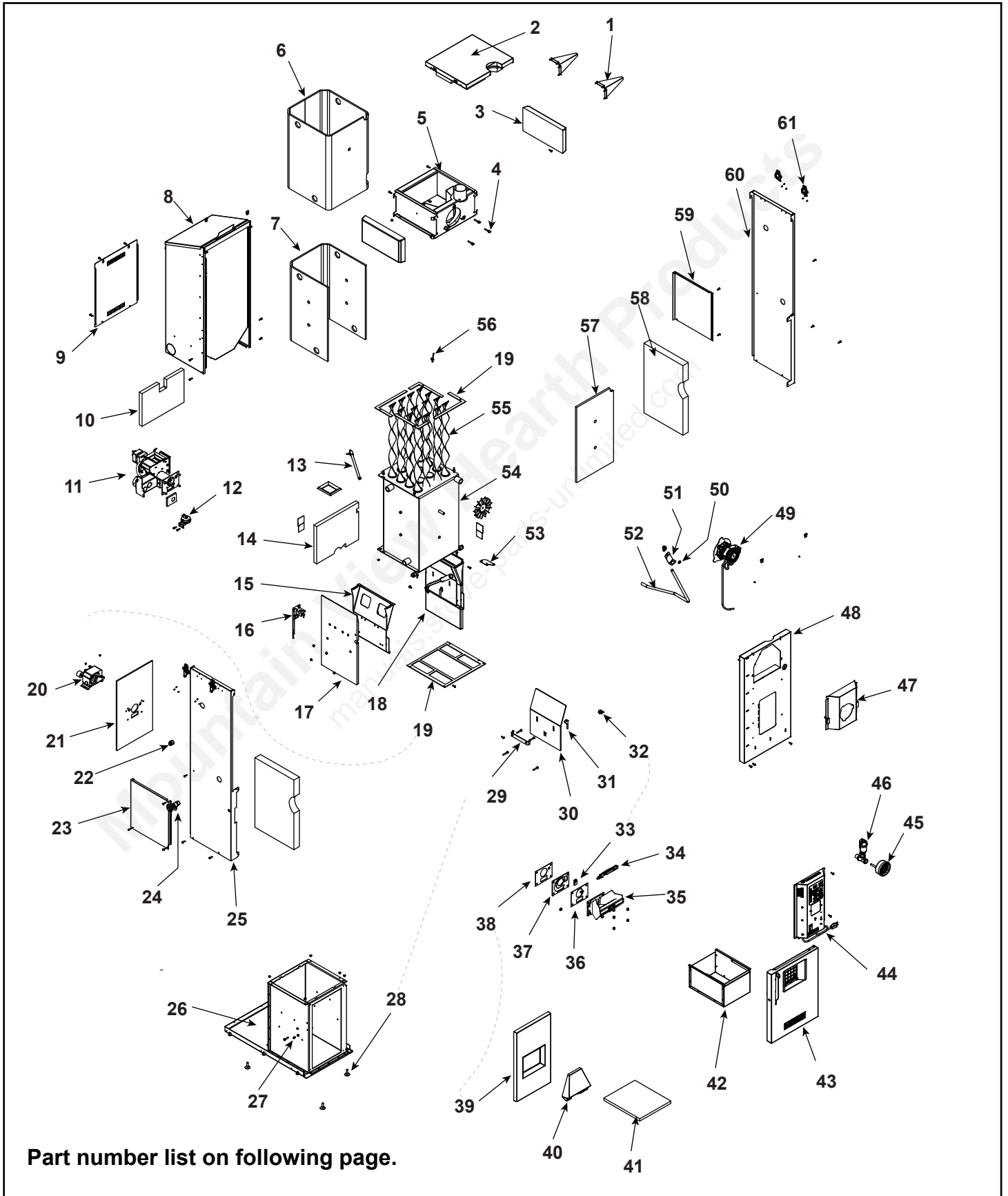

Part number list on following page.

IMPORTANT: THIS IS DATED INFORMATION. When requesting service or replacement parts for your appliance please provide model number and serial number. All parts listed in this manual may be ordered from an authorized dealer.



**Stocked at Depot**

ITEM	Description	COMMENTS	PART NUMBER	
1	Plumbing Support Kit - Qty. 2 req.		1-10-232044	
2	Firetube Cleanout Door Assembly		1-10-232060A	
3	Draft Section Refractory Side	Qty. 2 req.	3-40-232054	
4	1/4-20 x 1-1/2" Wingscrew with Collar	Pkg of 10	3-31-782124-10	Y
5	Draft Section Weldment		1-10-232011W	
6	1/2" Foam Insulation Wrap Around		3-44-232089	
7	1/2" Foam Insulation		3-44-232088	
8	Hopper Assembly		1-10-232034A	Y
	Gasket, Hopper Throat		3-44-677185	Y
	Gasket, Hopper Top	20 Ft	1-00-375501	Y
9	Feeder Shield Rear		2-00-232039B	Y
10	1" Foil Faced Fiberglass Insulation		3-44-232085	

### #11 Feeder Assembly

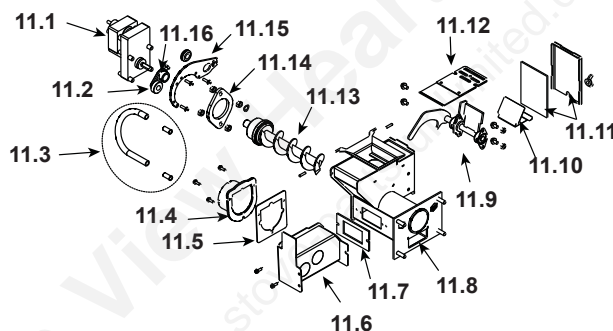

11	UL Feeder Assembly		1-10-232108A	
11.1	Pellet Feeder Gear Motor, 6RPM		3-20-09302	Y
	Feed Motor Fan Blade	Pkg of 3	3-20-09302-3	Y
11.2	UL Feeder Cam		3-31-3014	Y
11.3	Feeder Air Crossover Kit		1-00-67900	Y
	9MM Silicone Tube	5 Ft	1-00-511427	Y
11.4	Pellet Air Intake Assembly		1-10-06810A	
11.5	Gasket Feeder Air Intake	Pkg of 6	3-44-72224-6	Y
11.6	UL Feeder Air Intake		1-10-232114	
11.7	Gasket Ultra Air Intake	Pkg of 10	3-44-677160-10	Y
11.8	Ultra Feeder Weldment		1-10-72226S	Y
11.9	UL Feeder Pusher Arm		1-10-677187W	Y
11.10	Fines Deflector	<b>No longer available</b>	2-00-677138-10	
11.11	Gasket, UL Feeder Cover	Set of 2	1-00-677122	Y
11.12	Slide Plate Assembly		1-10-677121A	Y
11.13	UL Feeder Auger Assembly		3-50-00565	Y
11.14	Bearing Flange w/Hardware		1-00-04035	Y
11.15	UL Feeder Gear Motor Bracket w/Grommet		1-00-247406	Y
11.16	UL Feeder Cam Block		3-00-677154	Y

Additional service part numbers on the following page.

IMPORTANT: THIS IS DATED INFORMATION. When requesting service or replacement parts for your appliance please provide model number and serial number. All parts listed in this manual may be ordered from an authorized dealer.



**Stocked  
at Depot**

ITEM	Description	COMMENTS	PART NUMBER	
12	Differential Switch		3-20-6866	Y
13	Tempco 450W Igniter		3-20-00450	Y
14	1" Foil Faced Fiberglass Insulation		3-44-232086	
15	Tube Cleanout Plate	Qty. 2 req.	2-00-232008B	
16	Hopper Stiffener Bracket Left		2-00-232031-1B	
	Hopper Stiffener Bracket Right		2-00-232031-2B	
17	Firebox Refractory Side	Qty. 2 req.	3-40-232010	
18	Burn Pot Scraper		3-99-7498	
19	Water Jacket Gasket	Combustion	3-44-232094-1	
		Long Bottom	3-44-232094-2	
		Short Bottom	3-44-232094-3	
20	Air Pump		3-20-02679	Y
	Fitting & Filter		1-00-02679	Y
21	1/4" Ceramic Paper Feeder Insulation		3-44-232078	
22	3/4" NPT Square Plug	Qty. 4 req.	3-10-00600	
23	Feeder Cover Left		2-00-232096B	
24	3/4" NPT Boiler Drain		3-10-07560	
25	Outer Skin Left		2-00-232026B	
26	Combustion Section Weldment		1-10-232005W	
27	Steel Sleeve Bushing 3/8 OD x 1/2 OAL		3-50-05229	
28	Elevator Bolt 3/8-16 x 1-1/2"	Qty. 4 req.	3-30-937161501	
29	Firebox Cleanout Cover Retainer	Qty. 2 req.	2-00-232056B	
30	Tube Cleanout Cover Plate	Qty. 2 req.	2-00-232052B	Y
31	Tube Cleanout Latch	Qty. 2 req.	2-00-232009L	
32	3/8" Flex Connector	Qty. 2 req.	3-20-1000	
33	Ceramic Insert	Pkg of 10	3-20-05238-10	Y
34	Flame Guide		3-00-03000	Y
35	Burnpot Assembly		1-10-232079A	Y
	Clean Out Cover	2 Sets	1-00-06623	Y
	Thumb Screw	Pkg of 10	3-31-782108-10	Y
36	Ceramic Insert Gasket		3-44-724114	Y
37	Ceramic Insert Plate		2-00-724104	Y
38	Burn Pot Gasket		3-44-724115	Y
39	Firebox Refractory Rear		3-40-232015	Y
40	Firebrick		3-40-232093	Y
41	Firebox Refractory Bottom		3-40-232006	Y
42	Ash Pan Assembly		1-10-232049A	Y

Additional service part numbers on the following page.

IMPORTANT: THIS IS DATED INFORMATION. When requesting service or replacement parts for your appliance please provide model number and serial number. All parts listed in this manual may be ordered from an authorized dealer.



**Stocked  
at Depot**

ITEM	Description	COMMENTS	PART NUMBER	
43	Ash Door Assembly		1-10-232019A	
	Ash Door Spacer Set w/Gasket		1-00-232074	
	Glass 5.25 x 5.25		3-40-5555	
	Refractory		3-40-232023	
44	Control Board Plate Assembly		1-10-232055A	
	Control Board		1-00-06143	Y
	Fuse, 6 AMP	Pkg of 5	3-20-49447-5	Y
45	Pressure / Temperature Gauge		3-10-78427	Y
46	Plumbing Assembly		1-10-232080A	
47	Combustion Motor Cover	Pre SN 004490643	2-00-232028A	
		Post SN 004490643	2-00-232028B	
48	Outer Skin Front		2-00-232027B	
49	Combustion Blower		3-21-08639	Y
	Blade 5" Single		3-20-502221	Y
	Combustion Blower Mount		1-10-73416	
50	External Retaining Ring		3-31-004357	
51	Flex Conduit Support Bracket		2-00-232071B	
52	3/8" Flex Conduit		1-00-25043	Y
53	Ash Door Hinge		2-00-232020L	
54	Water Jacket Weldment		1-10-232001W	
55	Spiral Fire Tube Baffle	Pkg of 8	2-00-232053-8	Y
56	ESP Probe		3-20-00844	Y
	Aqua Temp Sensor Cable		3-20-72180	Y
57	1/2" Foam Insulation		3-44-232087	
58	2" Fiberglass Insulation	Qty. 2 req.	3-44-232090	
59	Feeder Cover Right		2-00-232097B	Y
60	Outer Skin Right		2-00-232025B	
61	Spring Latch	Qty. 4 req.	3-31-00927	Y
	3/8"-16 x 1/4" Alloy Steel Black Oxide Cup Point SSS	Pkg of 25	3-30-2014-25	Y
	Circuit breaker 10 Amp (orange - on/off switch)		3-20-334110	Y
	Diagnostic Display Module		3-20-05401	Y
	Draft Meter Assembly		1-00-00637	Y
	High Altitude Intake Reduction		1-00-23059	
	Wiring Harness		3-20-232076	Y



## Quick Reference ( Auto-Light )

- 1 Turn Mode Selector to OFF.
- 2 Scrape the air holes in the burnpot.\*\*
- 3 Fill the hopper with pellets.
- 4 Turn Feed Adjuster to "Test".\*
- 5 Check the Combustion Blower and Feeder Motor for operation.\*
- 6 Turn Feed Adjuster back to the #4, or previously known setting.
- 7 Turn the MAX TEMP dial to the desired temperature.
- 8 Turn MIN TEMP dial to the desired settings.\*
- 9 Flip the igniter switch to Auto.\*

The boiler will ignite if the temperature of the boiler water is less than the temperature set on MAX TEMP dial..

**\*See the section on Operation for information about Manual Lighting and Emergency Power.**

**\*\*See the section on Maintenance for more details about cleaning.**

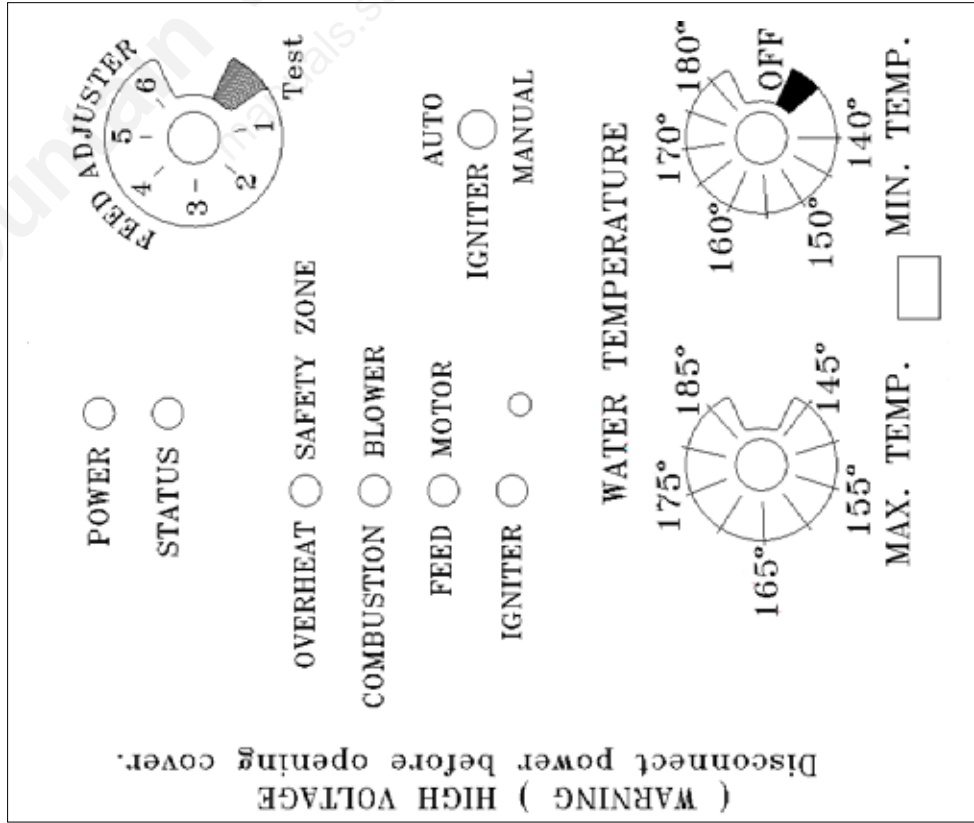

Mountain View Hearth Products  
manuals.stove-parts-unlimited.com

**HARMAN**<sup>TM</sup>

**BUILT TO A STANDARD, NOT A PRICE**

Proudly Printed On 100% Recycled Paper

