

Installation & Operating Manual

The Harman PB 105 Pellet Boiler

HARMANTM
BUILT TO A STANDARD, NOT A PRICE

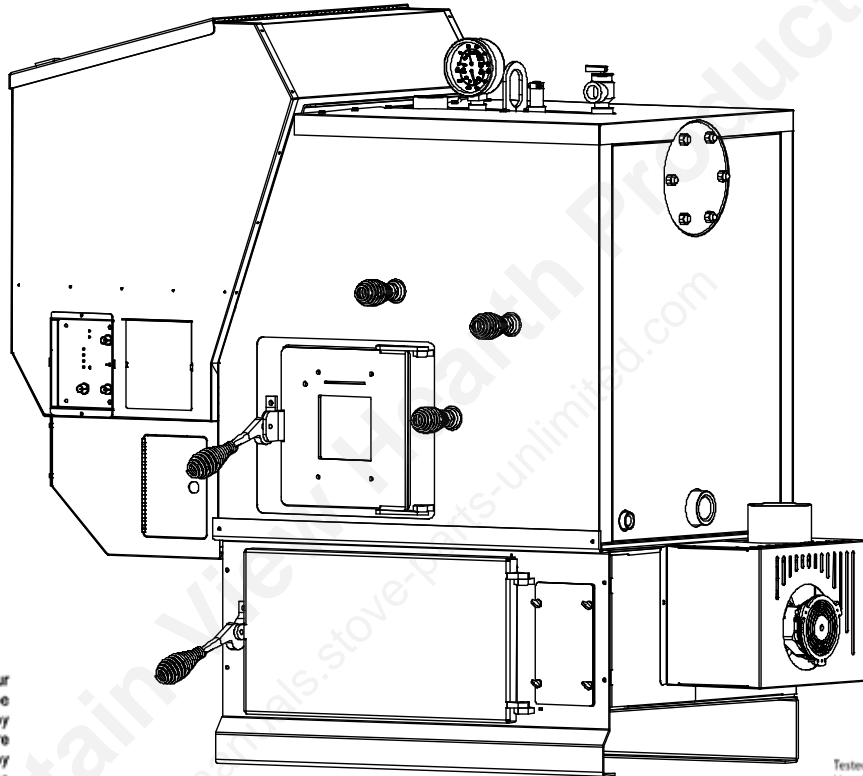

We suggest that our hearth products be installed and serviced by professionals who are certified in the U.S. by the National Fireplace Institute (NFI) as NFI Specialists.

“Ce manuel est disponible en Français sur demande”



R14

SAFETY NOTICE

WARNING! RISK OF FIRE OR EXPLOSION!

- IMPROPER INSTALLATION, OPERATION OR MAINTENANCE OF THIS BOILER CAN CAUSE INJURY OR DEATH.
- FOLLOW ALL INSTRUCTIONS CONTAINED IN THIS MANUAL

BEFORE INSTALLATION AND USE OF THIS BOILER:

- PLEASE READ AND UNDERSTAND THIS ENTIRE MANUAL.

CONSULT YOUR LOCAL AUTHORITIES HAVING JURISDICTION.

- CONTACT YOUR MUNICIPAL BUILDING DEPARTMENT, FIRE DEPARTMENT, OR OTHER LOCAL AUTHORITIES BEFORE INSTALLING THIS BOILER.
- LOCAL BUILDING REGULATIONS MAY REQUIRE SPECIAL PERMITS, RESTRICTIONS AND INSPECTION REQUIREMENTS.

SAVE THESE INSTRUCTIONS

3-90-07205

Mountain View Hearth Products
manuals.stove-parts-unlimited.com

Parts Locations

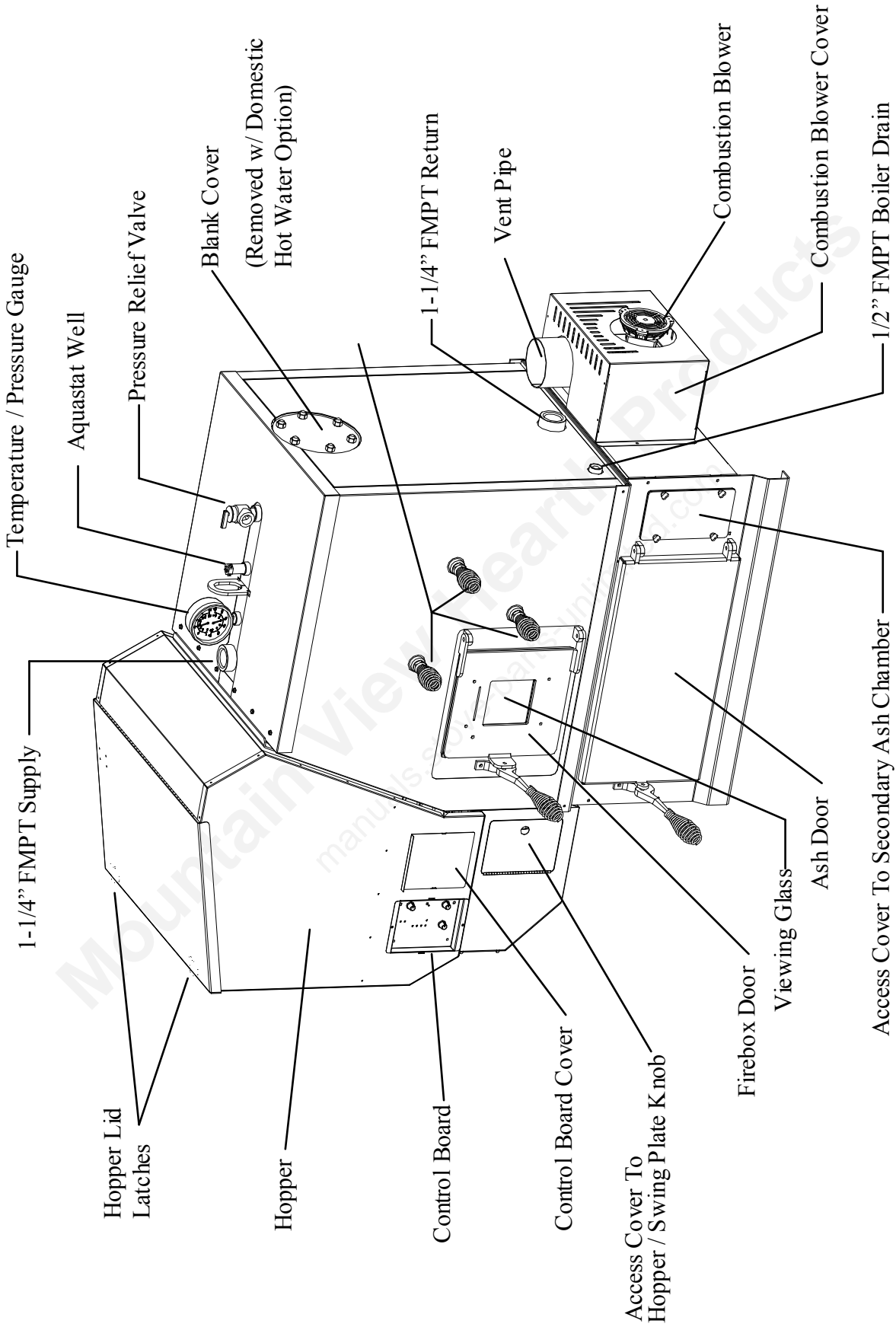

Introduction

Table Of Contents

Warranty	5
Assembly	6
Venting	9
Installation	12
Fuel Specifications	22
Operation	23
Maintenance	30
Troubleshooting	34
Atmospheric Conversion	35
Service Parts	36
Specifications	41
Wiring Diagram	42
Testing Label	44
Quick Reference Start-Up	Back Cover

Appliance Certification.

Model: Pellet Burning Boiler - PB105

Test Lab: Omni-Test Laboratories, Inc.

Report #: 135-S-16-6

Type: Pellet Fueled Central/Supplementary For Residential Use

Standard(s): CAN/CSA B366.1-M91, and UL 391

Note: This appliance is also approved for installation into a shop.

WARNING! RISK OF FIRE! Hearth & Home Technologies disclaims any responsibility for, and the warranty and agency listing will be voided by the following actions:

DO NOT:

- Install or operate a damaged appliance
- Modify the appliance
- Install other than as instructed by Hearth & Home Technologies
- Operate the appliance without fully assembling all components
- Operate the appliance without water in the system
- Overfire the appliance
- Install any component or part not approved by Hearth & Home Technologies

Improper installation, adjustment, alteration, service, or maintenance can cause injury or property damage. For assistance or additional information, consult a qualified installer, service agency or your dealer.

Please read this entire manual before you install and use your new boiler. Failure to follow instructions may result in property damage, bodily injury, or even death.

SAVE THESE INSTRUCTIONS

Hearth & Home Technologies, Inc.

352 Mountain House Road
Halifax, PA 17032

Warranty

HARMAN™ CENTRAL HEATING PRODUCTS LIMITED WARRANTY

Hearth & Home Technologies Inc., on behalf of its Harman™ brand ("HHT"), extends the following warranty for all Harman™ furnace and boiler products ("Products") that are purchased from an HHT authorized dealer.

Warranty Coverage: Subject to the conditions, exclusions and limitations set forth below, HHT warrants to the original owner of the Products, and to any transferee taking ownership of the Products at the site of original installation within two years following the date of original purchase, that the Products will operate free from defects in material and workmanship under normal conditions and use, as described in the operating instructions furnished with the Product, during the warranty period described below. HHT will, at its option, repair or replace any Product covered by this warranty that is determined to be defective in material or workmanship.

Warranty Period: The warranty period runs for six years, except for mechanical and electrical components, which are warranted for three years. The warranty period begins on the earlier of: (i) the date of invoice for the Product; (ii) in the case of new home construction, the date of first occupancy of the residence or six months after the date of sale of the Product by an HHT authorized dealer, whichever occurs first; or (iii) the date 24 months following the date of Product shipment from HHT, regardless of the invoice or occupancy date.

Warranty Conditions: This warranty applies only to Products: (i) installed, operated, and maintained as recommended in the Product user's manual; (ii) purchased through an HHT authorized dealer; (iii) while remaining at the site of original installation; and (iv) that have not been altered after leaving the factory.

How to File a Claim: Claims must be made within the warranty period to the dealer who sold the Product. If that dealer cannot provide the warranty service, contact the nearest HHT authorized dealer. Additional service fees may apply if you are seeking warranty service from a dealer other than the dealer from whom you originally purchased the Product. Travel and shipping charges for parts are not covered by this warranty.

Warranty Exclusions: This warranty does not cover the following: (1) consumable and normal wear items, including, without limitation, flame guides, grates, coal bars, afterburner hoods, fire brick, gaskets, paint, glass discoloration, burnpot housing weldments, burnpot grate weldments (pellet or corn), burnpot front plates (pellet or corn), burnpot front plate locks, corn auger extensions, ceramic inserts, and ceramic insert plates; (2) noise caused by minor expansion, contraction or movement of parts; (3) damage resulting from: (i) failure to install, operate or maintain the Product according to the installation and operating instructions and listing agent identification label furnished with the Product; (ii) failure to install the Product according to local building codes; (iii) shipping or improper handling; (iv) abuse, misuse, continued operation with damaged, corroded or failed components, accident, or incorrectly performed repairs; (v) environmental conditions, inadequate ventilation, negative pressure or drafting caused by tightly sealed construction, insufficient make-up air supply, or handling devices such as exhaust fans or forced air furnaces or other such causes; (vi) use of fuels other than those specified in the operating instructions; (vii) installation or use of components or accessories not supplied with the Product or authorized and approved in writing by HHT; (viii) modification of the product not expressly authorized and approved by HHT in writing; or (ix) interruptions or fluctuations of electrical power supply to the Product; (4) non-HHT components or accessories used in conjunction with the Product; (5) the Products' capability to heat a desired space; information is provided to assist the consumer and the dealer in selecting the proper Product for the application; consideration must be given to Product location and configuration, environmental conditions, insulation and air tightness of the structure; or (6) additional or unusual utility bills incurred due to any malfunction or defect in Products.

Limitations of Liability: Repair or replacement in accordance with the provisions of this warranty will be the owner's exclusive remedy for and will constitute HHT's sole obligation under this warranty, under any other warranty (express or implied), or in contract, tort or otherwise. No employee, agent, dealer, or other person is authorized to give any warranty on behalf of HHT. TO THE EXTENT ALLOWED BY LAW, HHT MAKES NO OTHER WARRANTY, EXPRESS OR IMPLIED, INCLUDING ANY WARRANTY OF MERCHANTABILITY OR FITNESS FOR A PARTICULAR PURPOSE. HHT WILL NOT BE LIABLE FOR ANY CONSEQUENTIAL OR INCIDENTAL DAMAGES ARISING OUT OF DEFECTS IN OR USE OF THE PRODUCTS. Some states do not allow exclusions or limitation of incidental or consequential damages, so these limitations may not apply to you. This warranty gives you specific rights; you also may have other rights, which vary from state to state. The duration of any implied warranty is limited to the duration of the warranty period specified herein.

Assembly

Boiler Kit Materials: (Refer to page 3)

List of items contained within the boiler kit shipped with the unit.

- 1 - Control board cover
- 1 - Access cover (Hopper Swing Plate Knob)
- 5 - Spring Handles
- 1 - 1/2" Boiler Drain
- 1 - 3/4" Safety Relief Valve
- 1 - 1/2" Aquastat Well
- 1 - 1/2" Dual Temperature/Pressure Gauge
- 1 - 100ft. Sensor Cable (Outdoor Air Sensor)
- 1 - Outdoor Air Sensor
- 1 - Flue Tunnel Weldment
- 1 - Combustion Blower Assembly
- 1 - Heat Shield (Comb. Blower)
- 2 - UY Connectors
- 2 - Terminals 1/4 Female
- 1 - #8 X 1/2" TEK
- 3 - 1/4-20 X 5/8" Wing Screw
- 4 - 1/4" Lock Washer
- 4 - 1/4-20 Nuts

Installation of the Flue Tunnel Weldment, Combustion Blower and Wiring, ESP and Heat Shield:

Step 1: First install the flue tunnel weldment by aligning the (4) studs with the (4) holes in the ash chamber base. Fasten the (4) nuts and lock washers provided, to the studs by removing the access cover on the secondary ash chamber.

Step 2: Place the combustion motor onto the flue tunnel weldment and tighten the (3) wing screws provided.

Step 3: Insert the Exhaust Sensing Probe (ESP) into the 1/8" hole provided on the flue pipe stub. Fasten with the (1) #8x1/2" TEK screw also provided. ESP will be taped to the sheet metal jacket for shipping purposes.

Step 4: Connect the flex conduit 90 degree elbow (Not Shown) to the heat shield in the hole provided. Then connect the (3) wires from the combustion blower with the (3) wires in the flex conduit by using the push-on connectors and matching the wire colors as follows: Red to Black, White to White and Green to Green.

Step 5: Place Heat Shield over combustion blower and align the swell latches with the holes in the sheet metal and tighten.

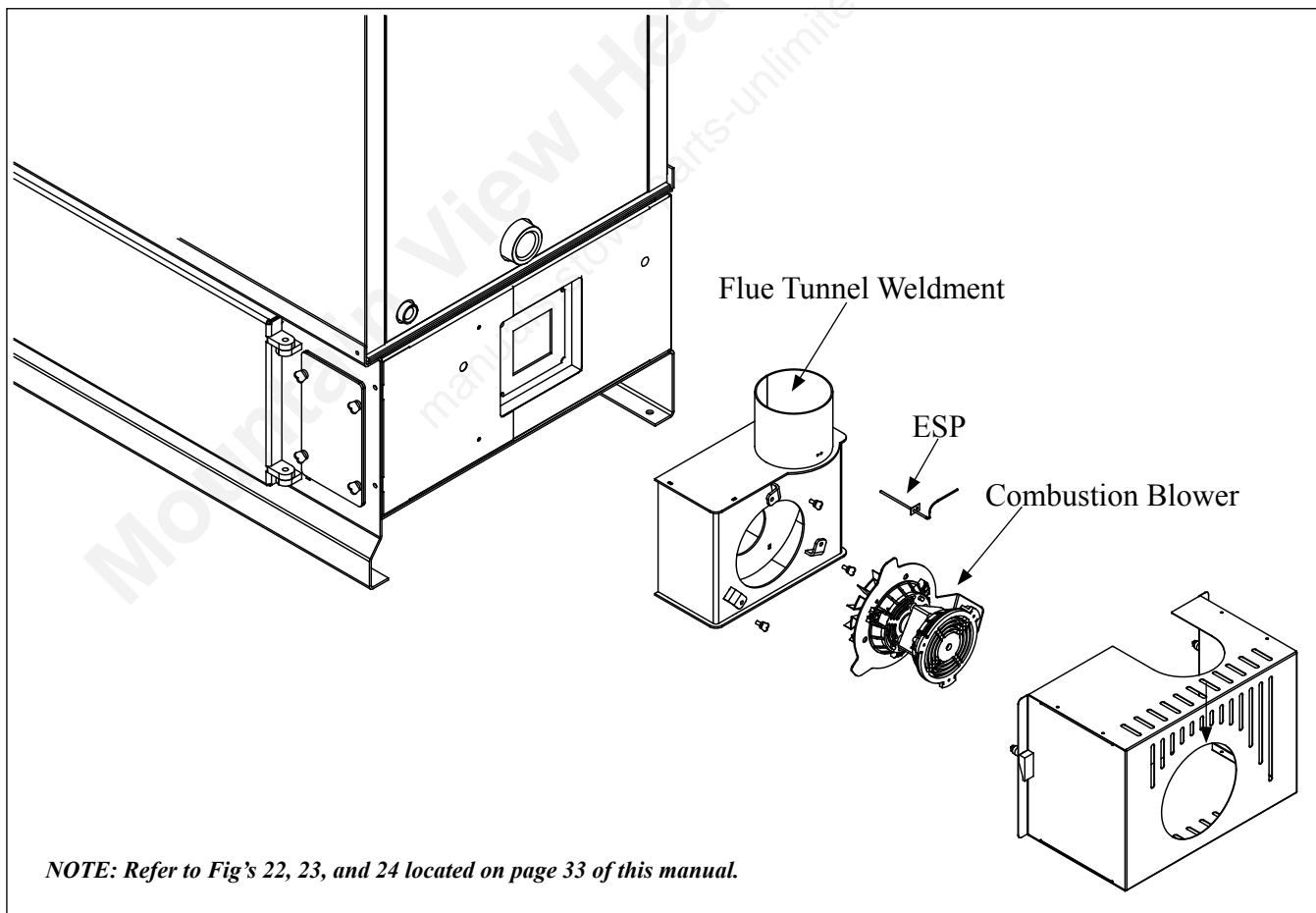

Assembly

Refer to the illustration on page 3 to identify the components listed below:

1. Install the control board cover as well as the access cover located on the feeder cover.

2. Install the spring handles provided with the unit on the ash door, firebox door and the heat exchanger cleanout rod handles. (Fasten handles by turning them counterclockwise and pushing inward simultaneously).

3. Install 1/2" MPT boiler drain in the fitting as shown.

Note: Use pipe thread sealant or teflon tape on ALL threads before connections are made.

4. Install 3/4" MPT pressure relief valve as shown.

5. Install the 1/2" MPT aquastat well in fitting as shown, then place aquastat in the well and fasten with a zip tie. The aquastat sensor is located under the top sheet metal jacket.

6. Install the 1/2" MPT temperature/pressure gauge in fitting as shown.

7. Locate and install outside air temperature sensor. Location of this sensor should be on the north side of the home or building and out of direct sunlight. Use the cable supplied with the boiler to attach the sensor to the terminals located on the hopper. (Place at the back side just above and to the right of the main power connection box) The wires can be connected to the sensor with the connectors supplied. Wire nut or butt splice connectors could also be used. The connections at the boiler can be done with the two 1/4" female push on connectors supplied.

8. Fasten the conduit to the ash base with the clamps provided.

Design:

The first thing that needs to be done is deciding where and how the boiler will be installed.

Things that need to be taken into consideration are the intended use of the boiler for example, is the boiler going to be used as your primary heating system or is it going to be used as a secondary or backup heating system. If it is to be used in conjunction with an existing oil or gas boiler system will it be piped in parallel or in series? The answers to these and other questions can be determined by talking to your certified dealer or a qualified HVAC or plumbing contractor. This will ensure that the boiler is installed and piped to accommodate your needs and expectations.

Consideration must be given to the venting as well as electrical and clearance requirements. (Clearances must be maintained to combustibles and also for service)

Make sure fans are not used in the fuel storage area, unless they are installed so as not to create a negative pressure in the room where the solid fuel burning appliance is located.

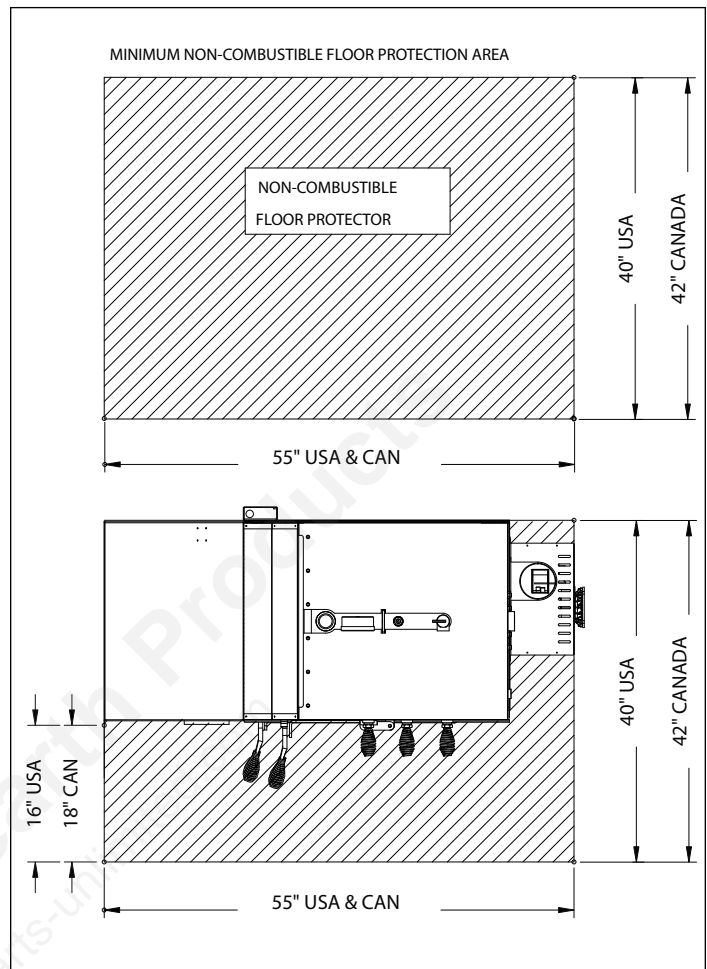

Floor Protection:

The striped area indicates the minimum required floor protection area if the boiler is going to be placed on a combustible floor. It requires 40" X 55"(US) or 42" X 55"(CAN) of non combustible floor protection as shown. 16"(US) or 18"(CAN) of the floor protection must be in front of the firebox door as shown. Floor protection must be a minimum of 26 gauge sheet metal. Floor protection must also be provided under any horizontal run of vent pipe equal to the outside diameter of the venting plus 2" to each side.

Example: 4" type "L" or "PL" vent pipe has an outside diameter of 4-1/2" + 2" on each side equals a protected floor area of 8-1/2" wide underneath the horizontal run.

Assembly

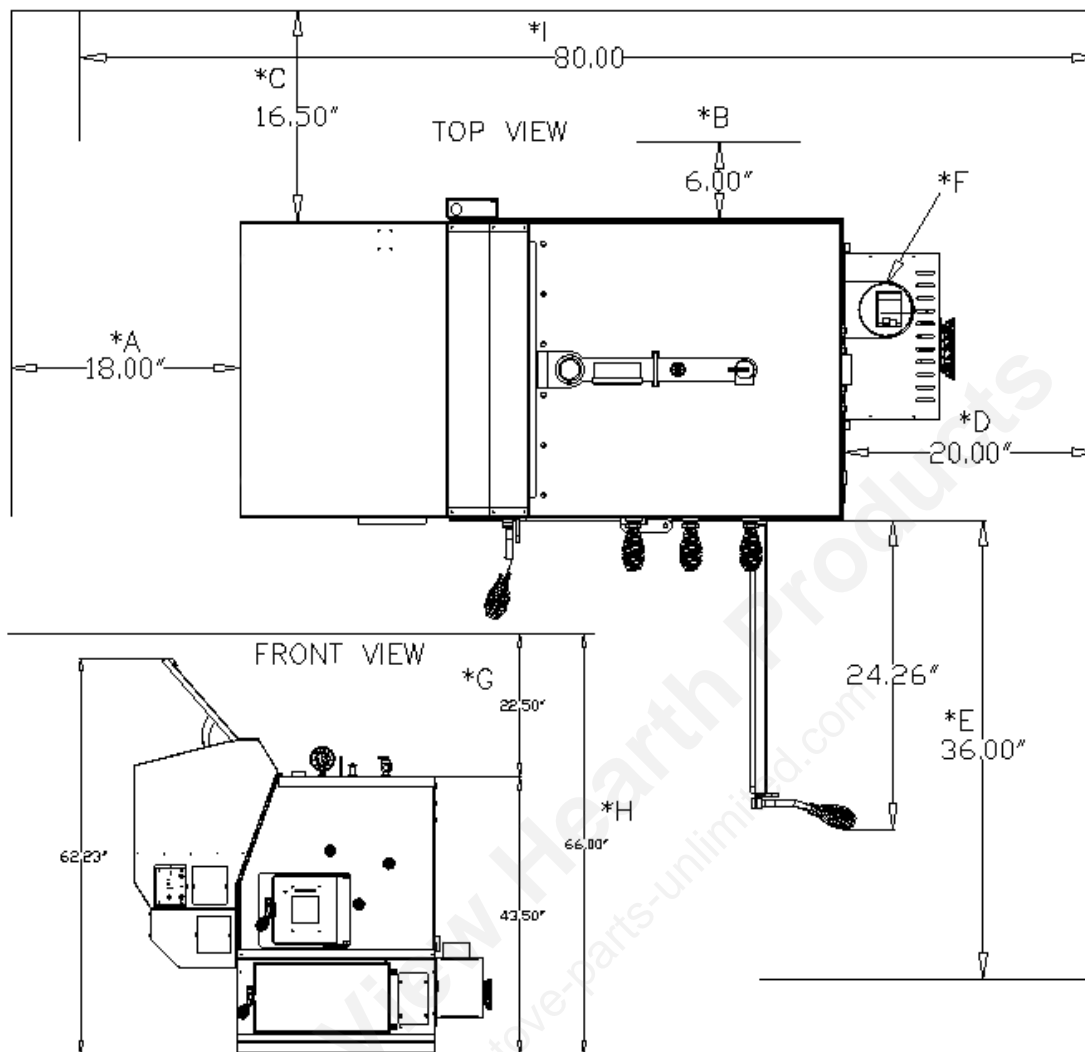

***NOTES:**

- A. Manufacturer Recommended minimum clearance.
- B. Minimum clearance to combustibles BUT NOT RECOMMENDED! (SEE NOTE C).
- C. Mfr's Recommendation to allow for full opening of feeder swing plate = 16.5"
- D. Minimum Clearance to allow servicing of combustion blower = 20"
- E. Minimum clearance to combustibles = 36"
- F. Pellet Vent clearance to combustibles = 1"
- G. Stovetop to ceiling = 22.5"
- H. Minimum ceiling height or alcove height = 66"
- I. Maximum alcove depth = 80"

INSTALLATION IS TO BE PERFORMED BY A QUALIFIED INSTALLER.

NOTE: All installation clearances and restrictions must be adhered to.

NOTE: Use only 4" diameter type "L" or "PL" venting system. Be sure to inspect and clean exhaust venting system frequently.

Venting

Requirements for Terminating the Venting

WARNING: Venting terminals must not be recessed into a wall or siding.

NOTE: Only PL vent pipe wall pass-throughs and fire stops should be used when venting through combustible materials.

NOTE: Always take into consideration the effect the prevailing wind direction or other wind currents will cause with flyash and /or smoke when placing the termination.

In addition, the following must be observed:

- A. The clearance above grade must be a minimum of 18".¹
- B. The clearance to a window or door that may be opened must be a minimum of 48" to the side, 48" below the window/door, and 12" above the window/door.¹
- C. A 12" clearance to a permanently closed window is recommended to prevent condensation on the window.
- D. The vertical clearance to a ventilated soffit located above the terminal within a horizontal distance of 2 feet (60 cm) from the center-line of the terminal must be a minimum of 18".
- E. The clearance to an unventilated soffit must be a minimum of 12".
- F. The clearance to an outside corner is 11" from center of pipe.
- G. The clearance to an inside corner is 12".
- H. A vent must not be installed within 3 feet (90 cm) above a gas meter/regulator assembly when measured from the horizontal center-line of the regulator.¹

I. The clearance to service regulator vent outlet must be a minimum of 6 feet.¹

J. The clearance to a non-mechanical air supply inlet to the building or the combustion air inlet to any other appliance must be a minimum of 48".¹

K. The clearance to a mechanical air supply inlet must be a minimum of 10 feet.¹

L. The clearance above a paved sidewalk or a paved driveway located on public property must be a minimum of 7 feet.^{1,2}

M. The clearance under a veranda, porch, deck or balcony must be a minimum of 12 inches.^{1,3} **(B Also applies)**

NOTE: The clearance to vegetation and other exterior combustibles such as mulch is 36" as measured from the center of the outlet or cap. This 36" radius continues to grade or a minimum of 7 feet below the outlet.

¹Certain Canadian and or Local codes or regulations may require different clearances.

²A vent shall not terminate directly above a sidewalk or paved driveway which is located between two single family dwellings and serves both dwellings.

³Only permitted if veranda, porch, deck, or balcony is fully open on a minimum of 2 sides beneath the floor.

NOTE: Where passage through a wall, or partition of combustible construction is desired, the installation shall conform to CAN/CSA-B365. (if in Canada)

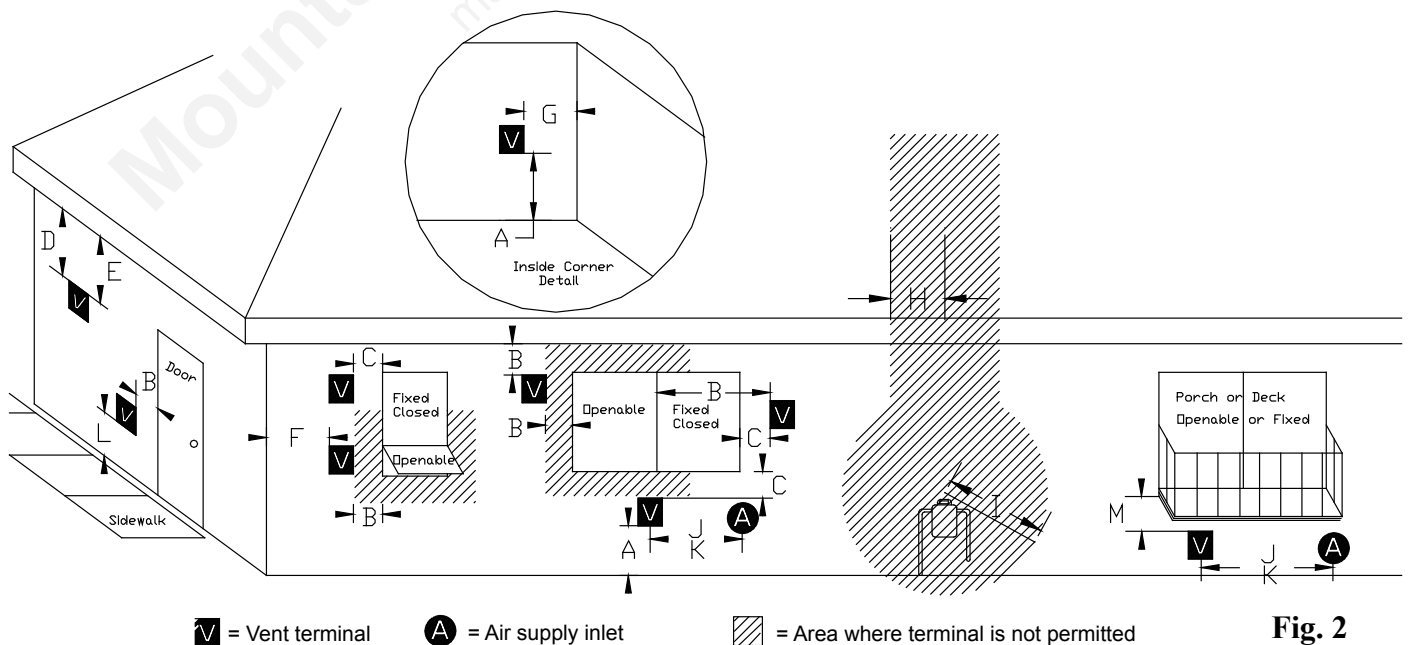
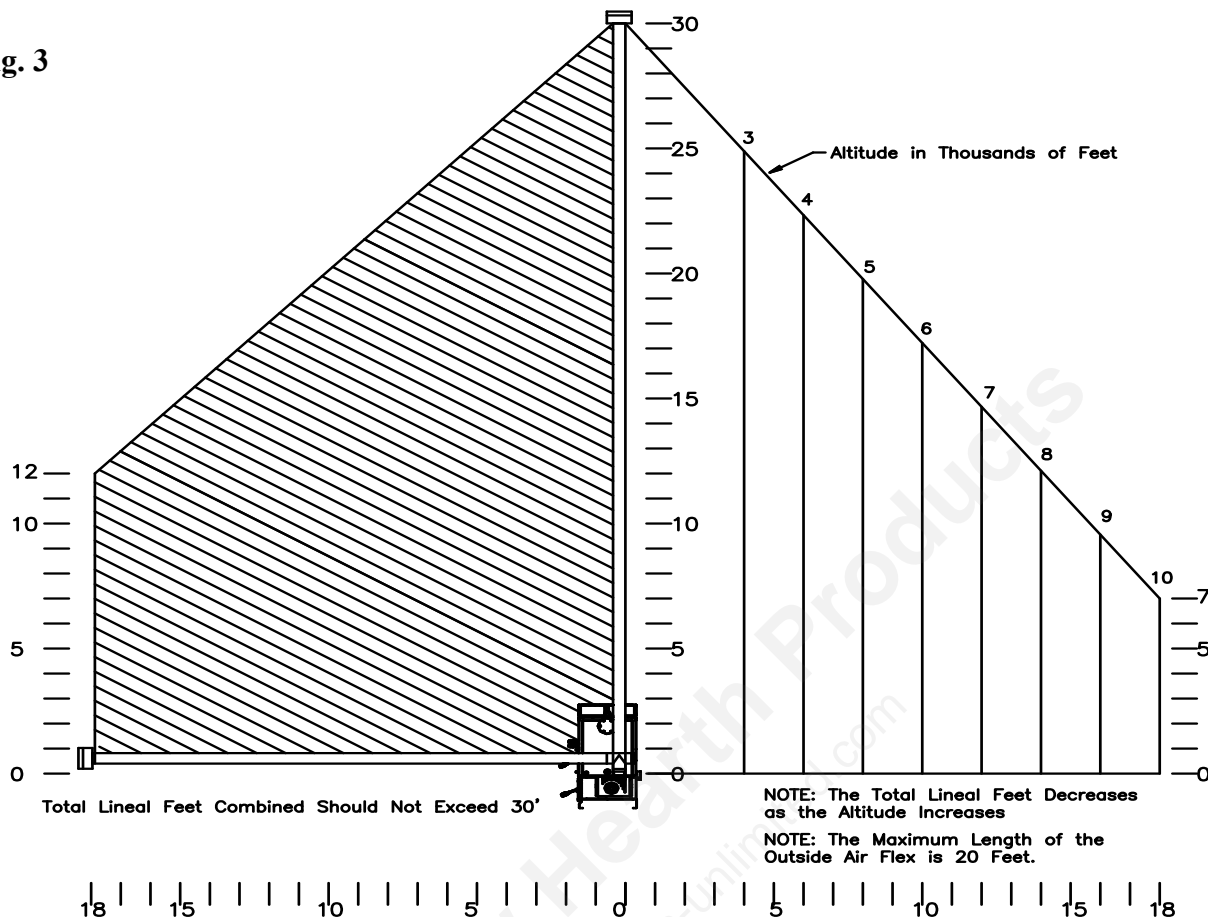

Fig. 2

Venting

Fig. 3



Avoiding Smoke and Odors - Negative Pressure, Shut-down and Electrical Power Failure.

To reduce the probability of back-drafting or burn back in the pellet boiler during a power failure, it must be able to draft naturally without exhaust blower operation. Negative pressure in the house will resist this natural draft if not accounted for during installation. Heat rises in a house, and leaks out at upper levels. This air must be replaced with air from outside the dwelling, which normally flows into lower levels. Vents and chimneys into basements and lower levels can become the conduit for return air and reverse under these conditions.

Hearth & Home Technologies strongly recommends the use of outside air in all pellet boiler installations, especially those on lower level and main floor locations. Per national building codes, consideration must be given to combustion air supply to all combustion appliances. Failure to supply adequate combustion air for all appliance demands may lead to back-drafting of those and other appliances within the home.

To reduce the probability of reverse drafting during shut-down conditions, Hearth & Home Technologies strongly recommends:

- Installing the pellet vent with a minimum vertical run of 5 feet. Preferably terminating above the roof line.
 - Installing the outside air intake at least four feet below the vent termination.
- To prevent soot damage to exterior walls, and to prevent re-entry of soot or ash into the house:
- Maintain specified clearances to windows, doors and air inlets, including air conditioners.
 - Vents should not be placed below ventilated soffits. Run the vent above the roof.
 - Avoid venting into alcove locations.
 - Vents should not terminate under overhangs, decks or onto covered porches.
 - Maintain minimum clearance of 12" from the vent termination to the exterior wall. Extending this distance may be required if visual accumulation occurs.

Venting

Venting

Use 4" pellet vent pipe only.

A combustion blower is used to extract the combustion gases from the firebox. This creates a negative pressure in the firebox and a positive pressure in the venting system as shown in Fig. 4. The longer the vent pipe and more elbows used in the system, the greater the flow resistance. Because of these facts we recommend using as few elbows as possible and 30 feet or less of vent pipe. The maximum horizontal run should not exceed 18 feet.

Be sure to use wall and ceiling pass through fittings (which are approved for pellet vent pipe) when going through combustibles materials. Be sure to use a starting collar to attach the venting system to the stove. **The starting collar must be sealed to the stove flue collar with high temp silicone caulking or aluminum tape, and screwed into the stove flue collar at least three (3) places.**

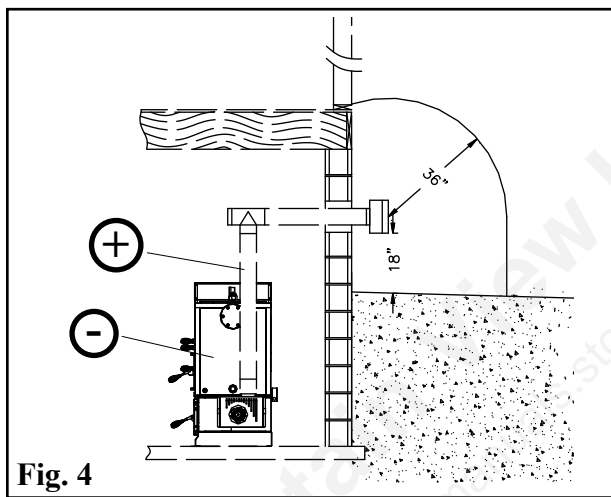

Vent Pipe

4" pellet vent pipe (also known as "PL" vent) is constructed of two layers with air space between the layers. This air space acts as an insulator and reduces the outside surface temperature to allow a minimum clearance to combustibles as low as 1 inch. In Canada the minimum clearance to combustibles is 3 inches.

The sections of pipe lock together to form an air tight seal in most cases; however, in some cases a perfect seal is not achieved. For this reason and the fact that the boiler operates with a positive vent pressure, **we specify that all joints within the structure should also be sealed with silicone.**

NOTE: Use only 4" diameter approved PELLET venting system. Be sure to inspect and clean exhaust venting system frequently.

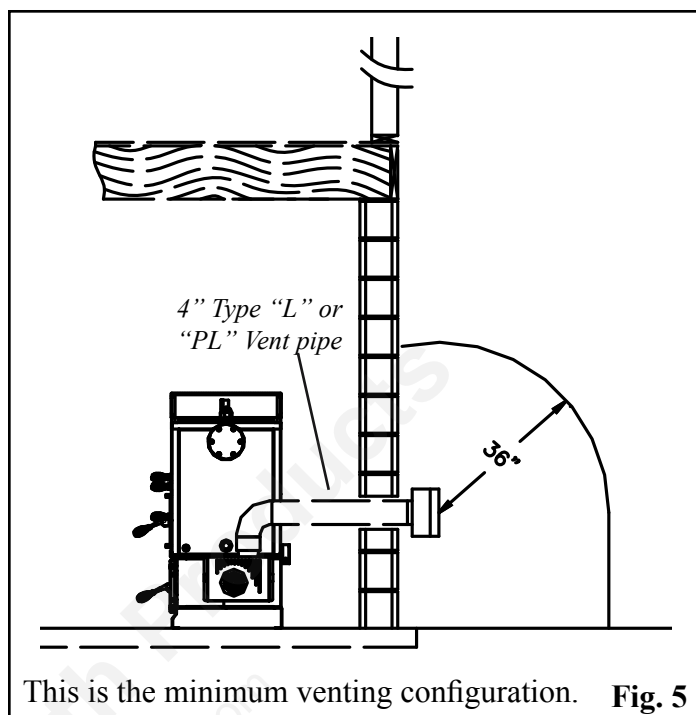

The minimum vent configuration is a 90° or Tee on a starter collar and a 24" length horizontal through an exterior wall. A cap on the end should direct the flue gasses down and away from the structure. See Fig. 5.

The maximum horizontal length is 18 feet. The minimum termination height above the exterior grade is 18". The maximum total length of any configuration is 30 feet*.

* (see venting graph on page 10 for exceptions)

NOTE: Cleanout Tee's should always be used on the transitions to horizontal pipe to allow easy access for cleaning.

The venting graph allows for one(1) 90 deg. or Tee fitting in any configuration.

If more 90's, T's, or 45's are needed, the total length must be adjusted to allow for the added restriction.

Up to four (4) additional 90's, Tee's, or equivalent 45's can be added as long as the overall length is adjusted in accordance with the values listed below.

(See the venting graph on page 10.)

Each Vertical ---- 90 deg. or T subtract 2.5 feet

Each Vertical ---- 45 deg. subtract 1.5 feet

Each Horizontal - 90 deg. or T subtract 5.0 feet

Each Horizontal - 45 deg. subtract 2.5 feet

Any exterior venting (vent pipe exposed to outside ambient temperatures) should be kept to a minimum, due to potential condensation problems.

This is especially important in high humidity cold weather climates, such as maritime areas, lake shores, and low river valleys.

Venting Installation

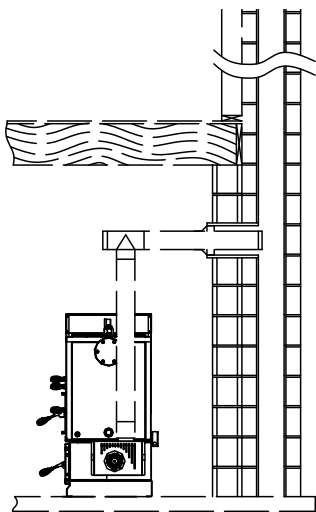

NOTE: Use only 4" diameter approved pellet venting system. Be sure to inspect and clean exhaust venting system frequently.

INSTALLATION IS TO BE PERFORMED BY A QUALIFIED INSTALLER.

DO NOT INSTALL A FLUE DAMPER IN THE EXHAUST VENTING SYSTEM OF THIS UNIT.

DO NOT CONNECT THIS UNIT TO A CHIMNEY FLUE SERVING ANOTHER APPLIANCE.

INSTALL VENT WALL PASS-THROUGHS AT CLEARANCES SPECIFIED BY THE VENT MANUFACTURER

NOTE: All installation clearances and restrictions must be adhered to.

NOTE: Read and follow all of the vent pipe manufacturers' instructions on the proper installation and support of the vent pipe. Adhere to all clearances.

Chimneys taller than 20' above the connection will require a draft test to determine if the draft is too high. Note: The high burn draft should not exceed .85 IWC. Some form of a restrictor plate may be required at the top of high chimneys to reduce the draft. See page 21 for the Draft Test procedure.

This boiler may be used and installed into an existing masonry or Class A metal chimney.

Certain Canadian and Local Codes may require that the chimney be fully relined.

The venting Can Not be installed in a chimney serving another appliance.

The chimney should be cleaned and or inspected before installation of the venting.

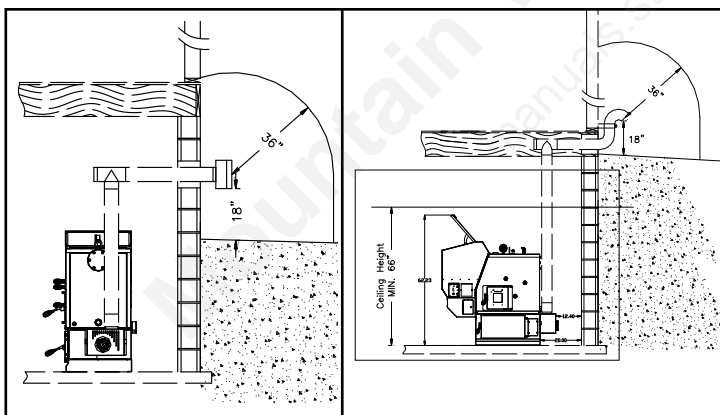

WARNING

KEEP COMBUSTIBLE MATERIALS SUCH AS GRASS, LEAVES, ETC. AT LEAST 3 FEET AWAY FROM THE POINT DIRECTLY UNDER THE VENT TERMINATION. (BETWEEN THE VENT AND THE GROUND)

CAUTION

KEEP COMBUSTIBLES AWAY FROM FLUE OUTLET.

Other examples of possible installations of the venting.

Creosote - Formation and Need for Removal - When wood is burned slowly, it produces tar and other organic vapors, which combine with expelled moisture to form creosote. The creosote vapors condense in the relatively cool chimney flue of a slow-burning fire. As a result, creosote residue accumulates on the flue lining. When ignited, this creosote makes an extremely hot fire. The pellet vent pipe should be inspected at least twice monthly during the heating season to determine if a creosote buildup has occurred. If creosote has accumulated it should be removed to reduce the risk of a chimney fire.

Guidance on minimizing creosote formation and the need for periodic creosote removal: The chimney should be inspected during the heating season to determine if a creosote build-up has occurred. If a significant layer of creosote has accumulated (3mm or more) it should be removed to reduce the risk of a chimney fire.

Installation

Outside Air

To install outside air, use 2 3/4" I.D. galvanized steel flex pipe, part # 2-00-08544 (12' 6" length) or part # 2-00-08545 (25' length) See Fig. 6. There is a break-away hole on the rear panel which must be removed before connecting the flex pipe. See Fig. 7.

When the appliance is side wall vented: The air intake is best located on the same exterior wall as the exhaust vent outlet, and located lower on the wall than the vent outlet.

When the appliance is roof vented: The air intake is best located on the exterior wall oriented toward the prevailing wind direction during the heating season.

Never terminate the outside air above the vent pipe outlet. The maximum length of this pipe is 20 feet. Inlet cover part number 1-10-09542 should be used to keep birds, rodents etc. out of the inlet pipe. See Fig. 6.

NOTE: The inlet cover should not be placed in an area where drifting of snow or ice will build up, blocking the intake air supply.

The Outside Air knockout is located on the face of the Feeder Cover. It is pre-cut except for several small tabs. There is also a filler plate screwed to the inside to cover the top of the hole after the Outside Air Pipe has been installed. This will allow for removal of the Feeder Cover without disconnecting the Outside Air Pipe. See Fig. 7.

Only metal Intake Flex should be used for the Outside Air Supply connection.

The Outside Air Intake Pipe is inside the Feeder Cover and to the right of the feeder motor. The 2 3/4" steel flex pipe is made to slide over the outside of the Air Intake Pipe. See Fig. 8. It should be held into place with some silicone, foil tape, or a hose clamp. (not supplied)

Heat Reclaiming Ventilation System (HRV)

When installing in a house with a Heat Reclaiming Ventilation System (HRV) be sure the system is balanced and is not creating a negative pressure in the house.

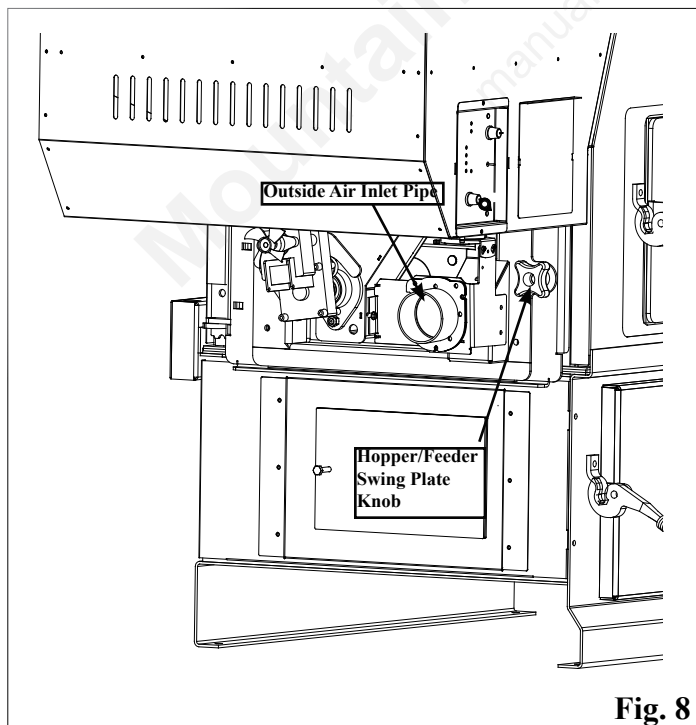
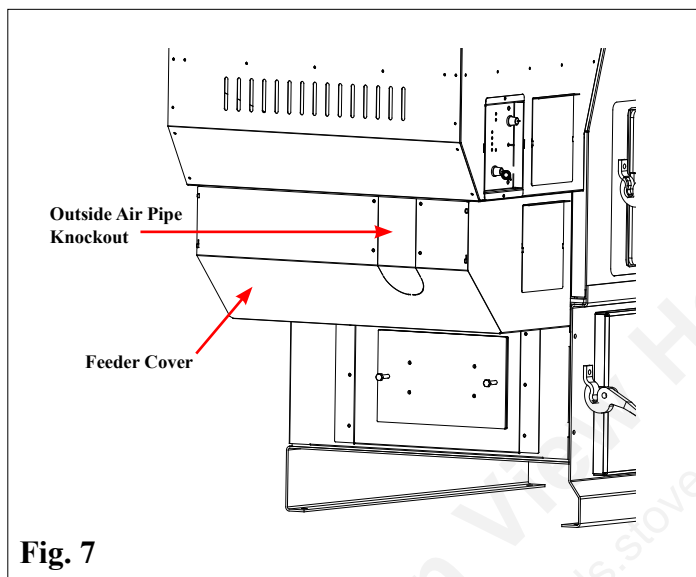
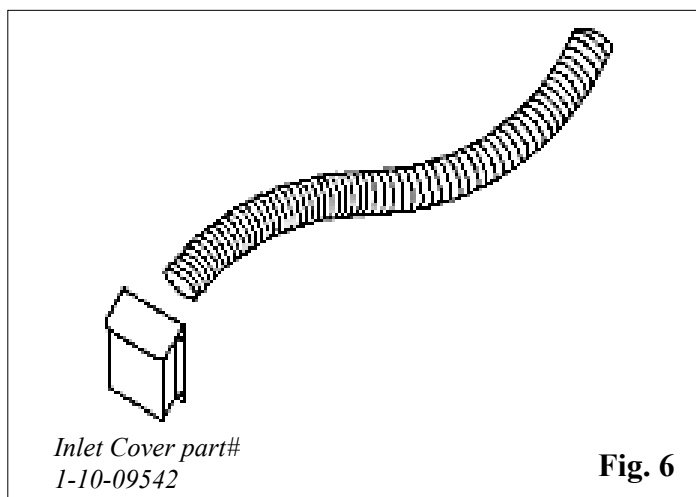

Main Wiring Installation

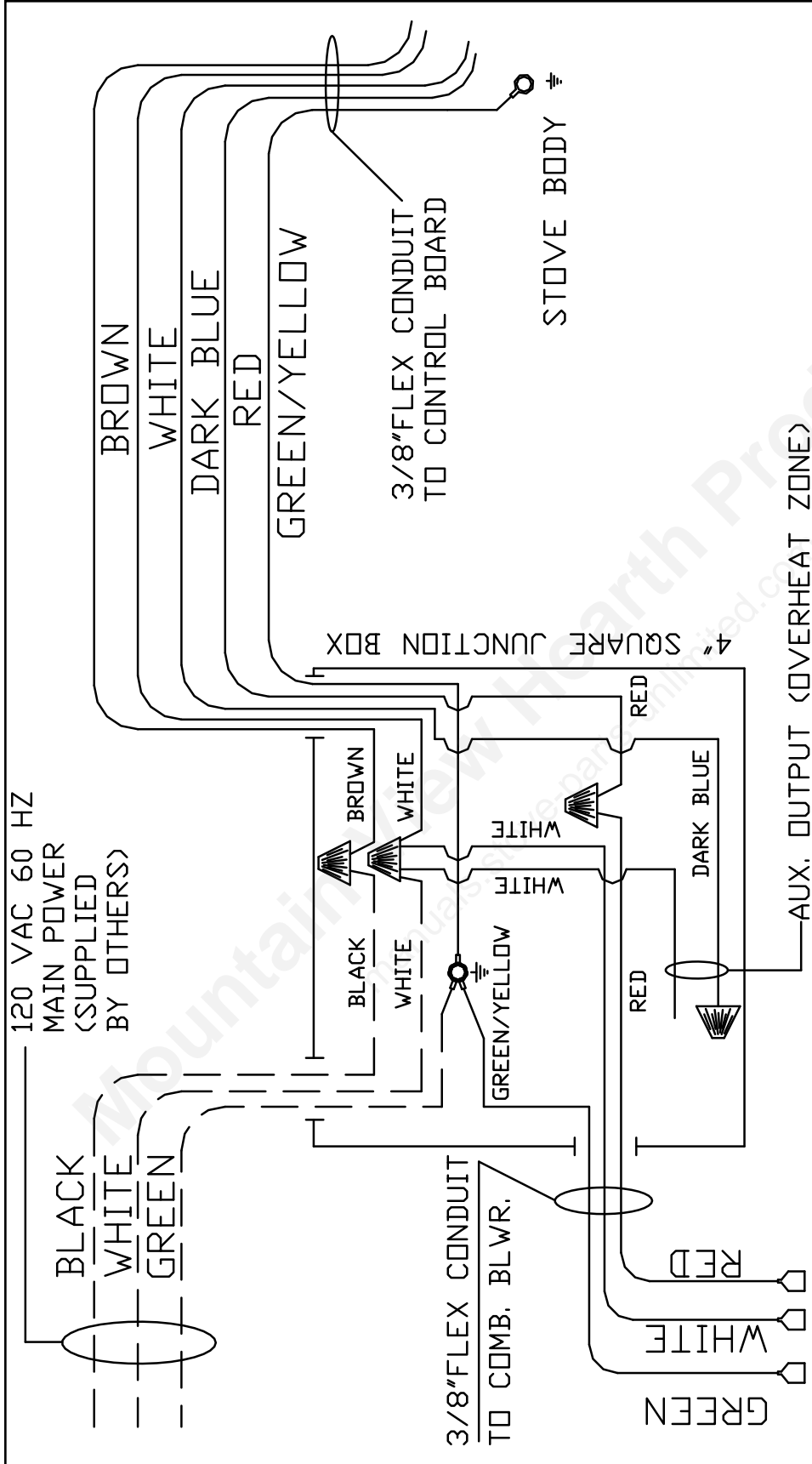

To install power to the boiler, first remove the cover on the 4" X 4" junction box located on the back of the unit. There are several knockout holes provided for the incoming main power wires. Also, a knockout hole can be used for the auxiliary output overhear zone (if used). The minimum recommended circuit is 6 AMP - 120 VAC - 60 HZ. This boiler should be the only appliance on the circuit.

This boiler should never be powered by the use of an extension cord.

The recommended high and low voltages are, 130 V.A.C. 60 Hz maximum high voltage, and 113 V.A.C. 60 Hz minimum low voltage. The furnace will continue to operate at voltages as low as 105 V.A.C., although it can not be guaranteed that automatic ignition will occur.

NOTE: If other sources of electrical power are to be used (such as a generator) for normal operation or emergency operation, this source should be checked before installation. Many generators and inverters may not supply 120V.A.C. 60Hz. power stable enough to operate the control board properly. (Control board damage could occur).

Installation

TYPICAL BOILER HOT WATER PIPING SHOWING AIR REMOVAL SYSTEM, PROVISIONS FOR THE EXPANSION OF WATER AND THE AUTOMATIC COLD WATER SUPPLY. ALSO SHOWN BUT NOT NECESSARILY NEEDED IS THE BOILER BYPASS LINE. THE NECESSITY OF THIS LINE WILL BE DETERMINED BY THE INSTALLING CERTIFIED PLUMBER OR HVAC CONTRACTOR.

NOTE: ALWAYS REFER TO THE INDIVIDUAL COMPONENTS RECOMMENDED INSTALLATION INSTRUCTIONS FOR THE PROPER MOUNTING POSITION AND LOCATION WITHIN THE PIPING SYSTEM.

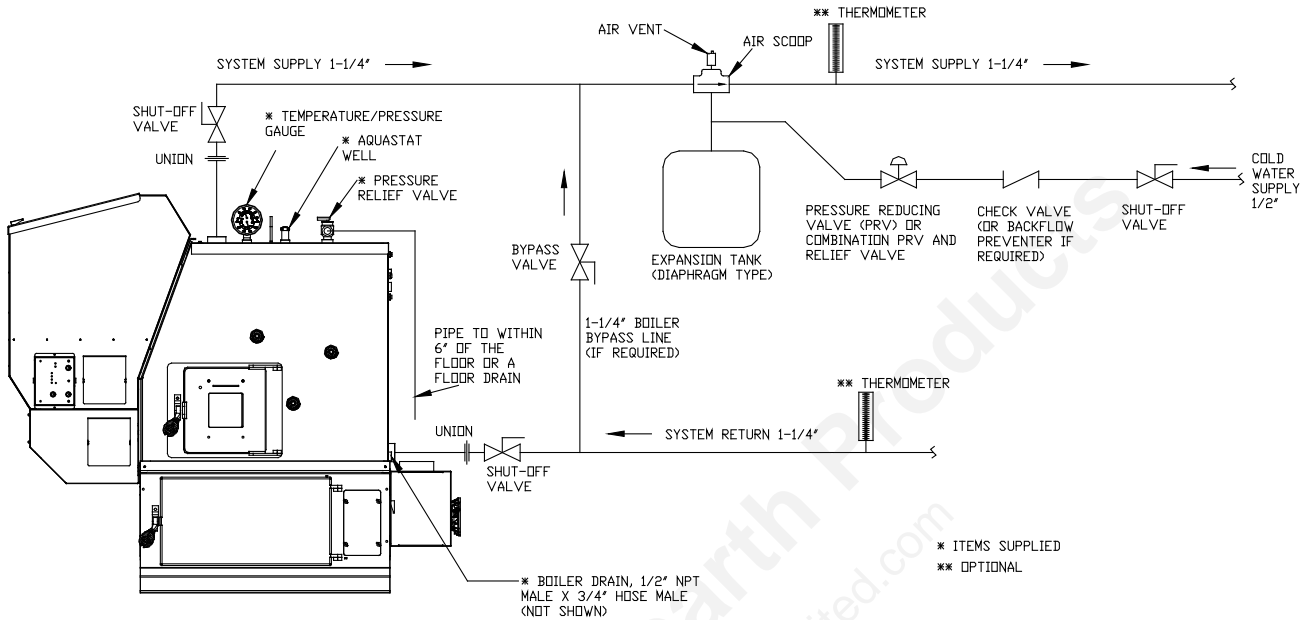

NOTE: Cold return water temperature (Sustained temperatures below 140 degrees Fahrenheit) will lead to condensation in the firebox. This moisture can lead to creosote formation. To help minimize moisture and creosote, it is strongly recommended that some form of temperature balance is incorporated into the return water system.

NOTICE: When installing with the atmospheric conversion: All of the pressurized system components shown are not necessary. Air vents or bleeders will need to be removed from the plumbing system to prevent air from entering the lines. Control Dipswitch #6 will need to be turned "ON".

EXAMPLE OF A TYPICAL MULTI-ZONE HEATING SYSTEM WITH BOILER BYPASS AND INDIRECT DOMESTIC HOT WATER ZONE

NOTE: ALWAYS REFER TO THE INDIVIDUAL COMPONENTS RECOMMENDED INSTALLATION INSTRUCTIONS FOR THE PROPER MOUNTING POSITION AND LOCATION WITHIN THE PIPING SYSTEM.

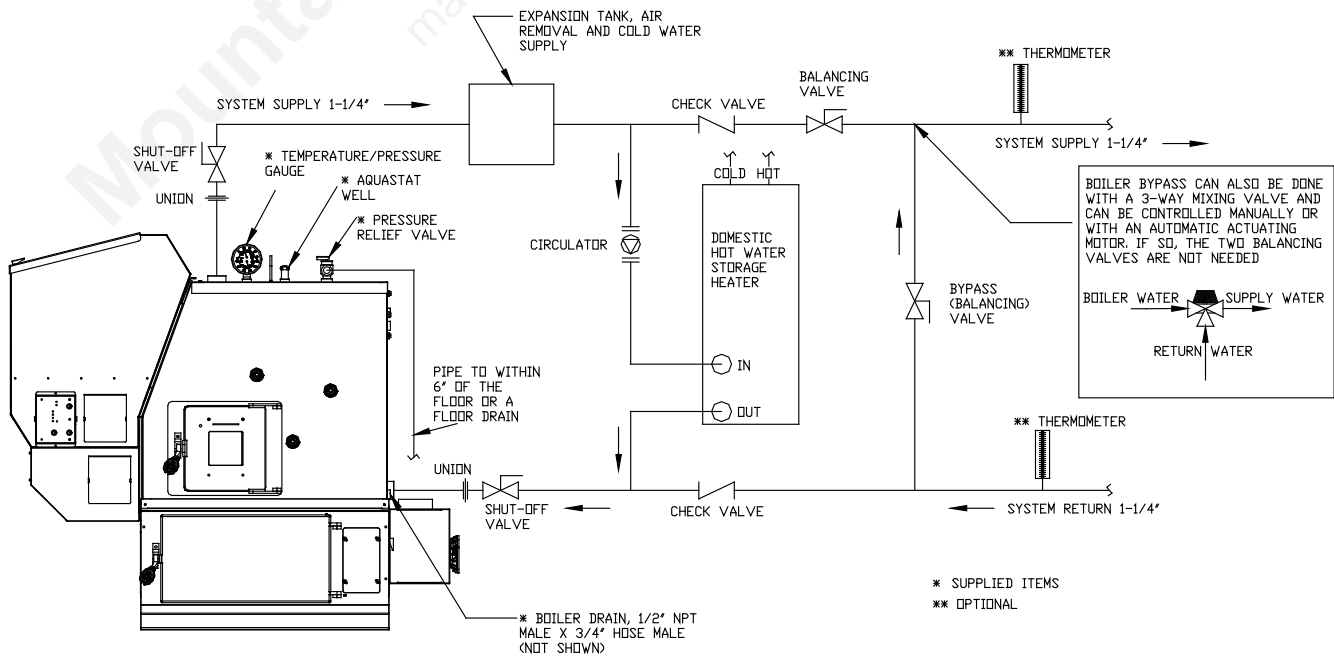

Installation

Boilers intended to be connected to an existing boiler or boiler system shall:

1. Be capable of being installed without interfering with the normal delivery of heated water from the original boiler to the radiation system.
2. Be capable of being installed to operate as intended without affecting the operation of the electrical and mechanical safety controls of the original boiler.
3. Provide, upon completion of the installation, for a change over from one fuel to the other without requiring the manual adjustment of any controls or components other than the thermostats.
4. Be compatible with the operation of a service water-heating coil within the original boiler without bypassing the operation of the solid-fuel boiler.
5. Have provision for preventing, or adequate water capacity within the boiler to prevent, damage to the boiler from loss of circulation due to electrical power failure.
6. Be capable of being installed without changing the function of the control or rewiring of the original boiler. A wiring interconnection is permitted. The electrical system of both boilers shall be powered from a single branch circuit without exception.
(CAN/CSA-B366.1-M91)
7. Pertaining to CAN/CSA- B365-01, Have a clearly labelled device, located at each entrance to the boiler area, which can be thrown to discontinue operation of the feed system.

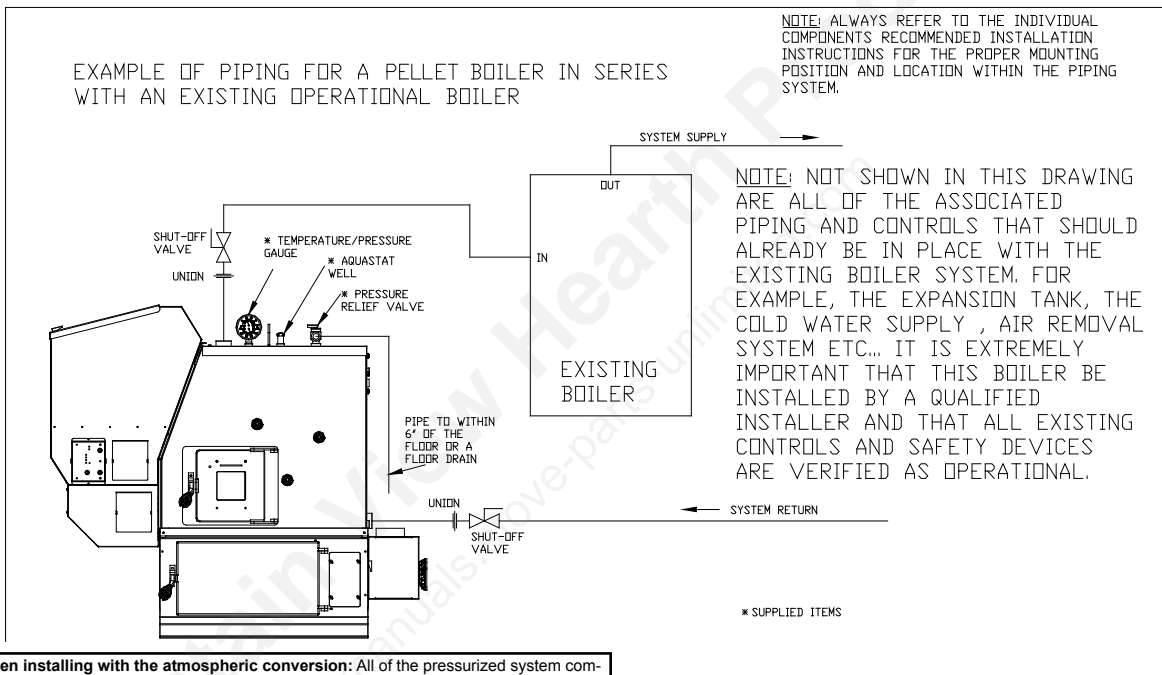

NOTICE: When installing with the atmospheric conversion: All of the pressurized system components shown are not necessary. Air vents or bleeders will need to be removed from the plumbing system to prevent air from entering the lines. Control Dipswitch #6 will need to be turned "ON".

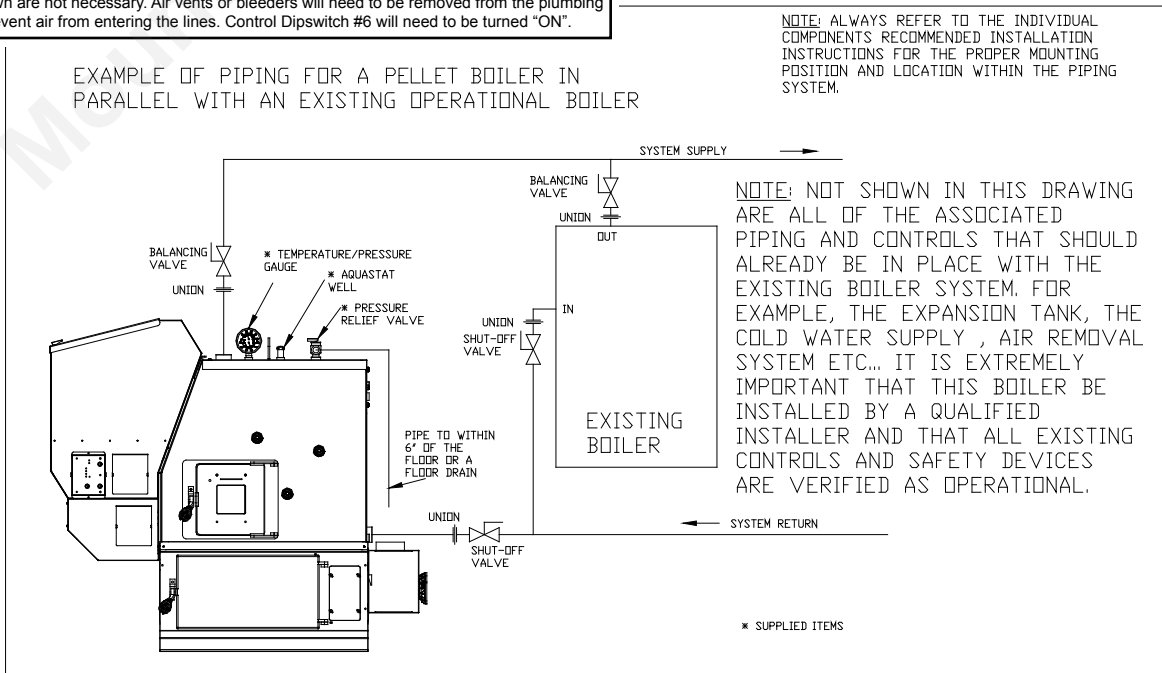

Installation

EXAMPLE OF TYPICAL TANKLESS DOMESTIC HOT WATER PIPING

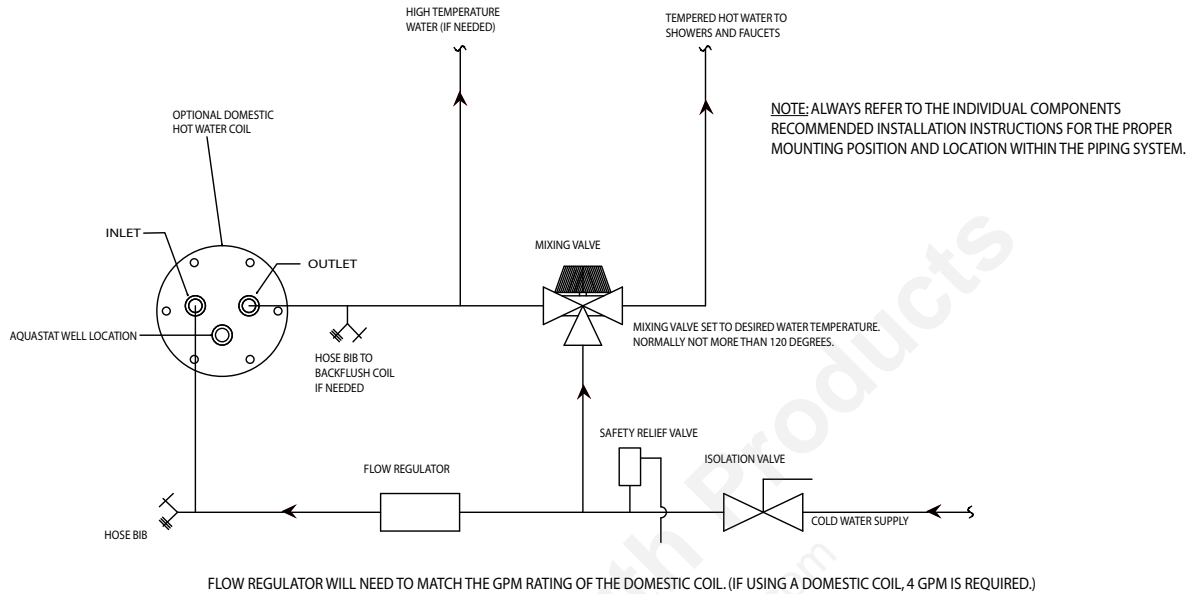

EXAMPLES OF TYPICAL DOMESTIC HOT WATER STORAGE PIPING

EXAMPLE #1

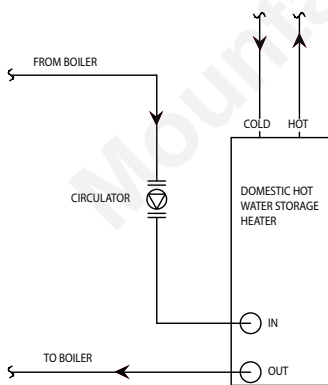

EXAMPLE #2

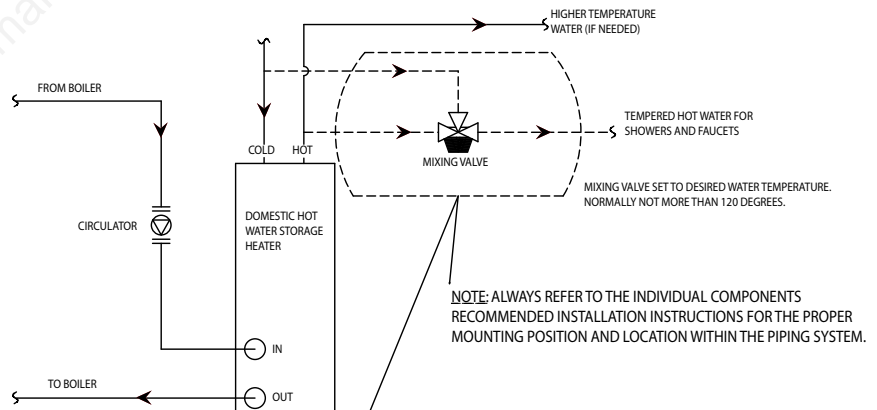

NOTE: TYPICALLY, AS LONG AS THE WATER TEMPERATURE NEEDED IS NOT MORE THAN 120°F, THE MIXING VALVE SHOWN ABOVE (EXAMPLE 2) IS NOT NEEDED

Installation

TYPICAL BOILER HOT WATER PIPING SHOWING AIR REMOVAL SYSTEM, PROVISIONS FOR THE EXPANSION OF WATER AND THE AUTOMATIC COLD WATER SUPPLY. ALSO SHOWN IS THE AUTOMATIC MIXING VALVE. THIS COULD ALSO BE DONE BY (2) CLOSELY SPACED TEE'S. THE PROPER PIPING FOR THE INTENDED USE WILL BE DETERMINED BY THE INSTALLING CERTIFIED PLUMBER OR HVAC CONTRACTOR.

NOTE: ALWAYS REFER TO THE INDIVIDUAL COMPONENTS RECOMMENDED INSTALLATION INSTRUCTIONS FOR THE PROPER MOUNTING POSITION AND LOCATION WITHIN THE PIPING SYSTEM.

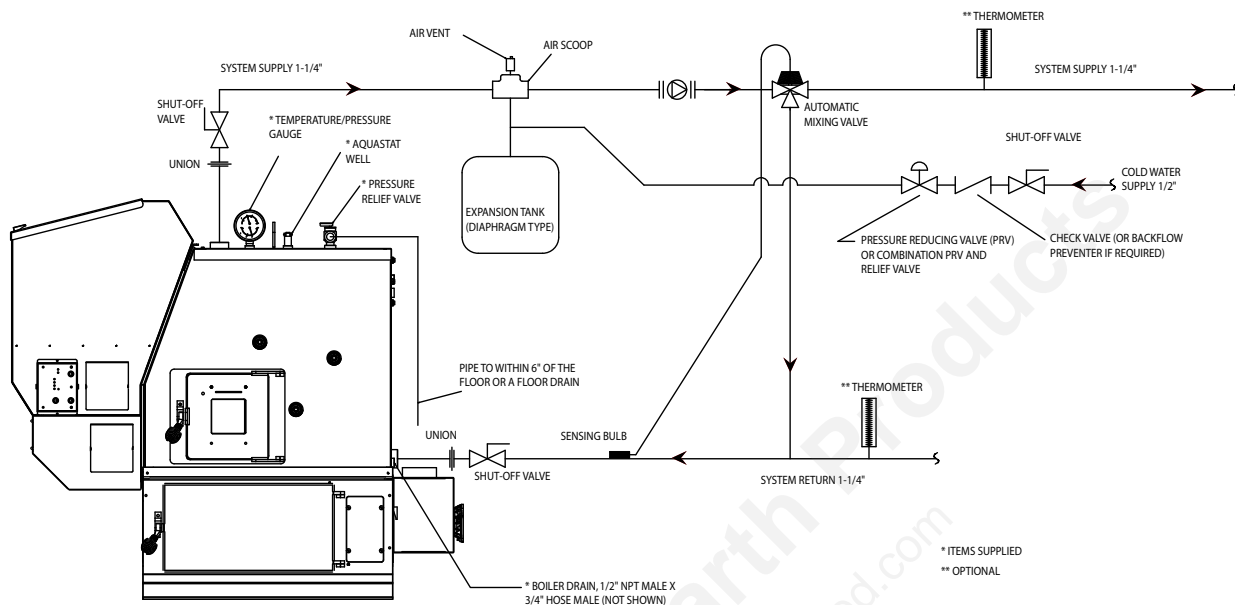

NOTE: Cold return water temperature (Sustained temperatures below 140 degrees Fahrenheit) will lead to condensation in the firebox. This moisture can lead to creosote formation. To help minimize moisture and creosote, it is strongly recommended that some form of temperature balance is incorporated into the return water system.

NOTICE: When installing with the atmospheric conversion: All of the pressurized system components shown are not necessary. Air vents or bleeders will need to be removed from the plumbing system to prevent air from entering the lines. Control Dipswitch #6 will need to be turned "ON".

EXAMPLE OF A TYPICAL MULTI-ZONE HEATING SYSTEM WITH INDIVIDUAL ZONE CIRCULATORS

NOTE: ALWAYS REFER TO THE INDIVIDUAL COMPONENTS RECOMMENDED INSTALLATION INSTRUCTIONS FOR THE PROPER MOUNTING POSITION AND LOCATION WITHIN THE PIPING SYSTEM.

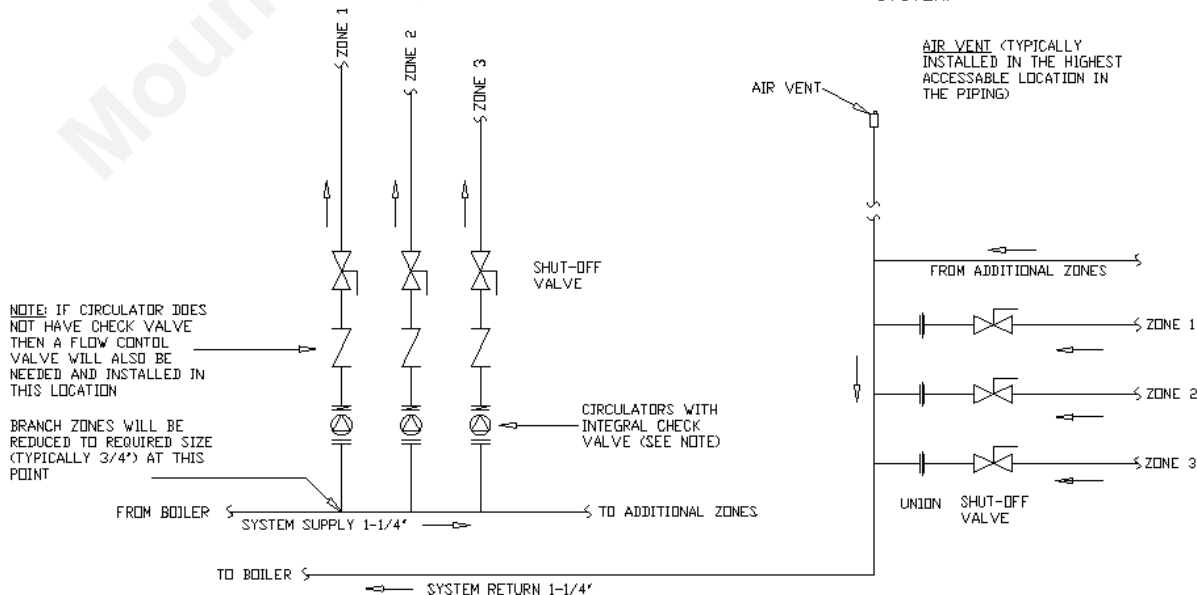

Installation

EXAMPLE OF A TYPICAL MULTI-ZONE HEATING SYSTEM WITH A SINGLE CIRCULATOR AND INDIVIDUAL ZONE VALVES

NOTE: ALWAYS REFER TO THE INDIVIDUAL COMPONENTS RECOMMENDED INSTALLATION INSTRUCTIONS FOR THE PROPER MOUNTING POSITION AND LOCATION WITHIN THE PIPING SYSTEM.

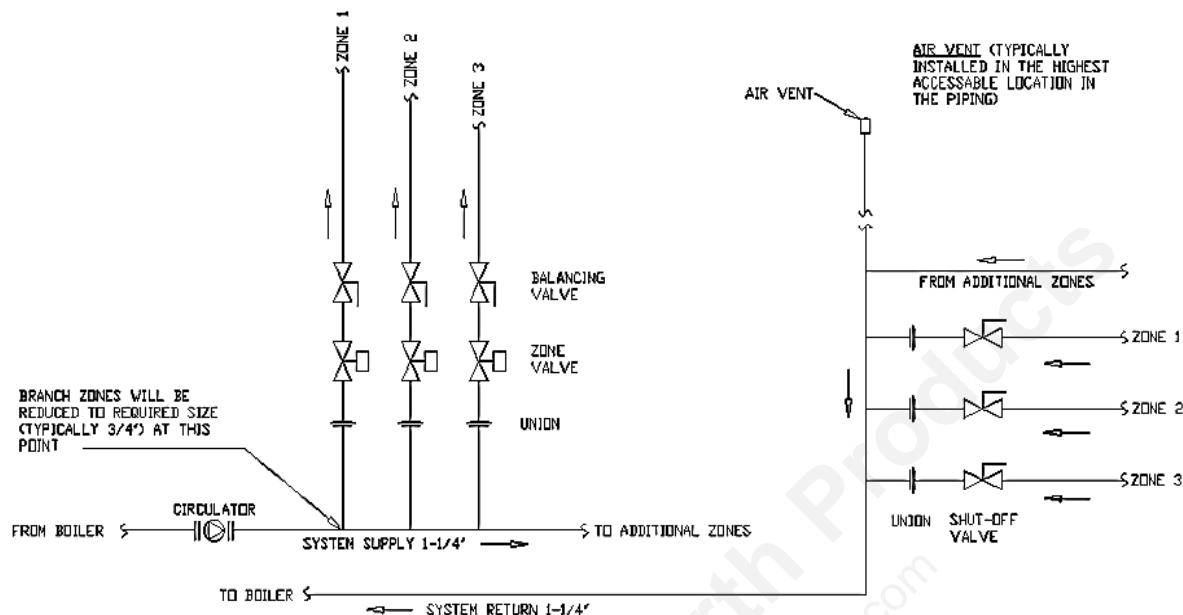

NOTE: Cold return water temperature (Sustained temperatures below 140 degrees Fahrenheit) will lead to condensation in the firebox. This moisture can lead to creosote formation. To help minimize moisture and creosote, it is strongly recommended that some form of temperature balance is incorporated into the return water system.

NOTICE: When installing with the atmospheric conversion: All of the pressurized system components shown are not necessary. Air vents or bleeders will need to be removed from the plumbing system to prevent air from entering the lines. Control Dipswitch #6 will need to be turned "ON".

EXAMPLE OF A COMBINATION HIGH/LOW MULTI-ZONE HEATING SYSTEM WITH INDIVIDUAL ZONE CIRCULATORS

NOTE: ALWAYS REFER TO THE INDIVIDUAL COMPONENTS RECOMMENDED INSTALLATION INSTRUCTIONS FOR THE PROPER MOUNTING POSITION AND LOCATION WITHIN THE PIPING SYSTEM.

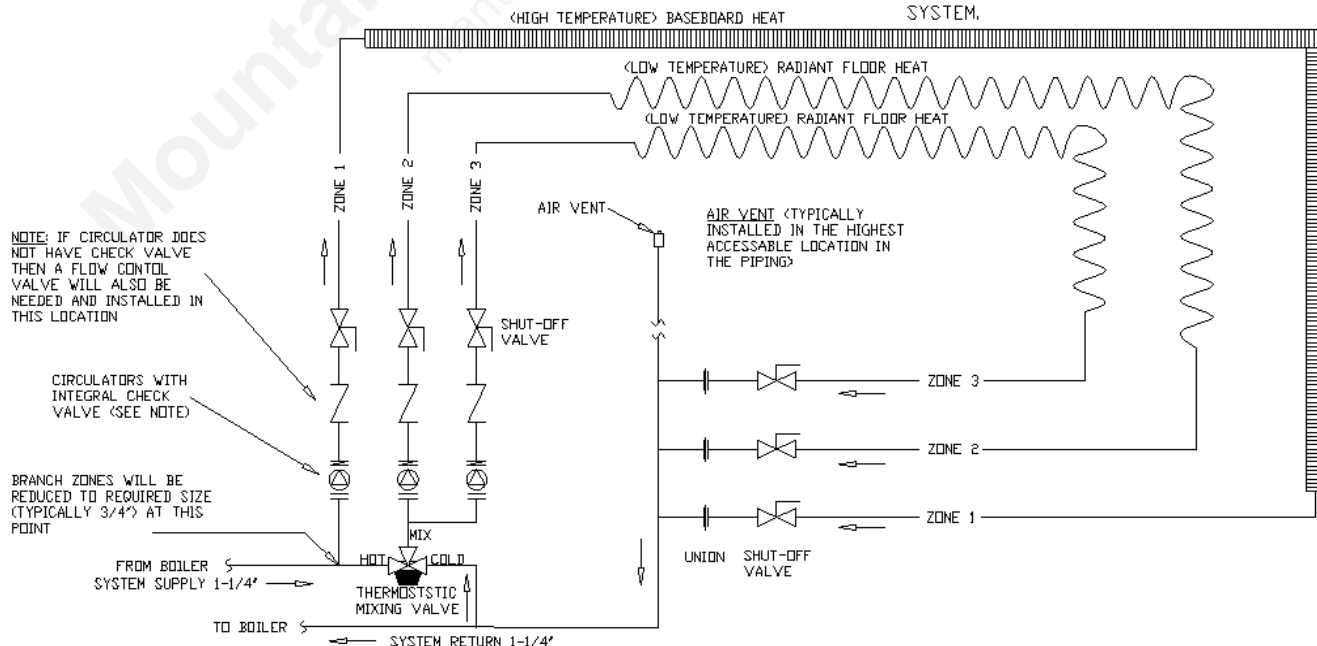

Over Heat Safety Zone

OverHeat Safety Zone (Dump Zone): STRONGLY RECOMMENDED in all installations.

When the pellet boiler is operating at High burn, and all demand from the heating system stops, the control will reduce the feed rate and shut down completely as necessary. This may take several minutes, and the remaining heat may cause the water temperature to continue to rise. If the temperature gets too high, the OVERHEAT SAFETY ZONE light on the control (see page 23) will illuminate, and the DARK BLUE circuit in the junction box is energized(see wiring diagram). This circuit will flow 120V to operate a circulator pump installed to flow to the overheat dump zone established in the original installation plan. If opening a zone valve is the chosen method of dumping the excess heat, a voltage reduction relay will most likely be needed. If the water temperature continues to rise to the risk of boiling point, the feed system will stop and the boiler will shut-down. A manual reset will then be required to operate the boiler. Without a dump zone in place, the excess temperature could build pressure to the point of opening the relief valve, or with the atmospheric conversion it may allow the water to boil and exit through the over-flow of the atmospheric tank. Both scenarios may create water damage and/or a slip hazard.

The boiling temperature of water varies at different altitudes and atmospheric pressures. Therefore, at elevations above 3000 feet, and when using the atmospheric conversion, circuit board dipswitch #6 must be in the "ON" position.

Power Failure / Heat Dissipation Loop

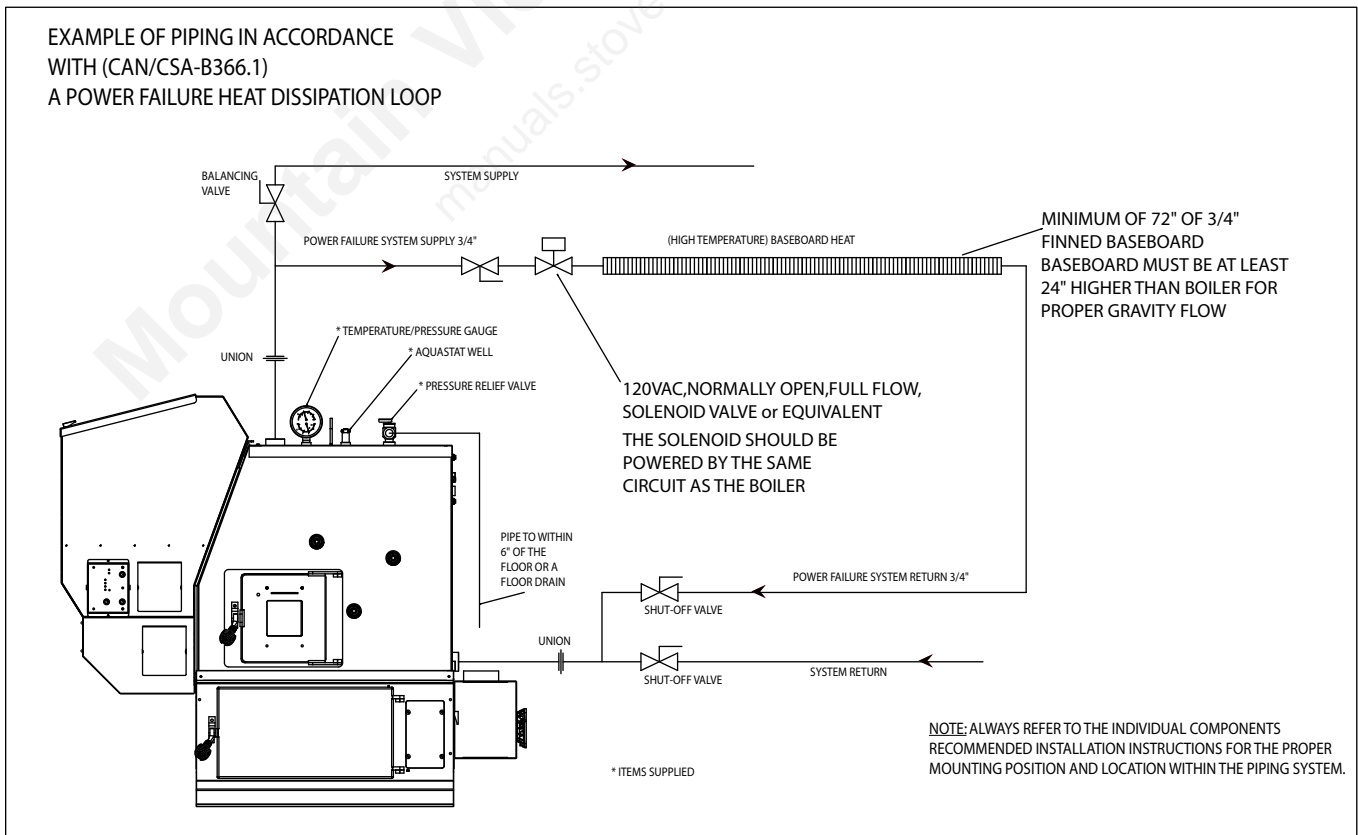

Installation

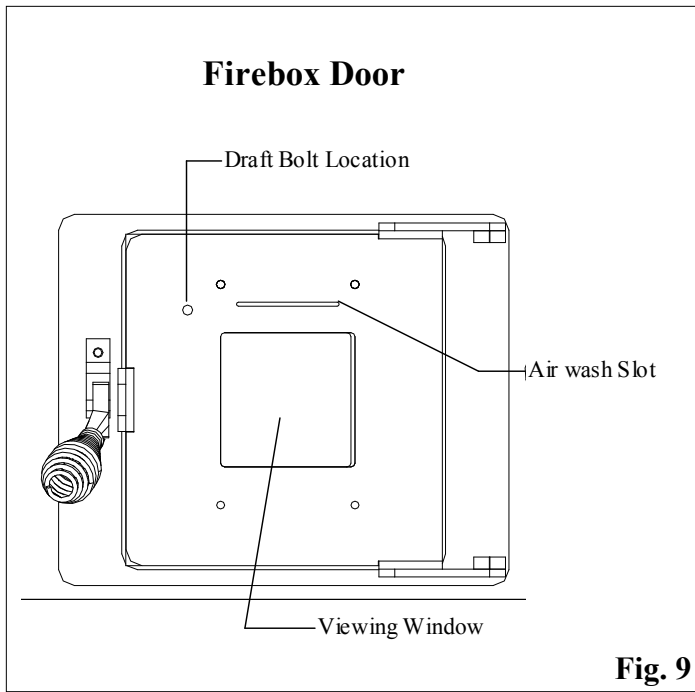

Fig. 9

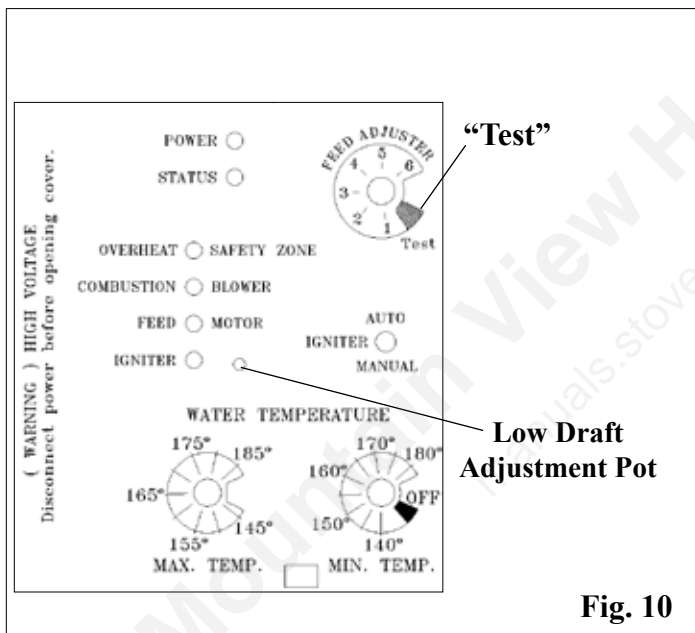

Fig. 10

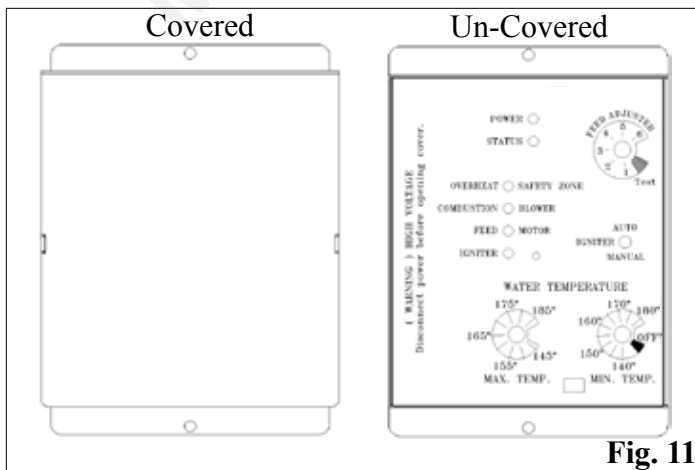

Fig. 11

Draft Test Procedure

After the venting is completed, the firebox low draft will need to be checked and possibly adjusted. After removing the 3/8" bolt from the draft hole shown in Fig. 9, insert the draft meter tube. The appliance doors and hopper lid must be latched during this test. (It is recommended that the draft meter have a scale of 0 to 1" WC.)

Turn the feed adjuster to "Test". this will start the combustion blower and allow you to check and record the High Draft _____ - IWC date _____. The maximum draft must not exceed -.85" W.C. Some form of vent restrictor may be needed. (There is no control board adjustment for the High Draft)

After the first 60 seconds the "Test" mode lowers the combustion blower voltage to the Low Burn voltage. During this lowered voltage cycle the **Low Burn Draft must be checked** and adjusted if necessary. The recommended low draft setting should be between -.25 & -.35 IWC. Depending on the amount of vertical rise, it may not be possible to get a low draft reading in this range. In this case, a maximum low draft of -.55 is acceptable.

The adjustment screw is through the small hole to the right of the Igniter Light. See Fig. 10. Adjusted Low Draft is _____ -IWC.

Don't forget to turn the feed adjuster off of "Test".

Do not operate if the high draft exceeds -.85" W.C.

Excessive draft readings may be due to restriction in the combustion air supply. Check for obstructions.

The Control

The boiler has the option to have the control panel covered or un-covered See Fig. 11. There is a pair of slots provided for each position. Simply move the cover to the desired position by placing the tabs on the cover in the proper slots.

CAUTION: Hot while in operation. Do not touch. Keep children, clothing, furniture, and other combustible material out of the installation clearance area.

WARNING: Do not operate with the hopper lid or fire chamber or ash removal doors open.

WARNING: Do not store fuel or other combustible material within installation clearance area.

Fuel Specifications

Fuel and Fuel Storage

Pellet fuel quality can fluctuate from manufacturer to manufacturer, and even from bag to bag.

Hearth & Home Technologies recommends using only fuel that is certified by the Pellet Fuels Institute (PFI).

Fuel Material

- Made from sawdust and/or other wood by-products
- Source material typically determines ash content

Higher Ash Content Material

- Hardwoods with high mineral content
- Bark and leaves as source material
- “Standard” grade pellets, corn and other biomass

Lower Ash Content Material

- Softwood; pine, fir, etc.
- Materials with lower mineral content
- “Premium” grade pellets

CAUTION! Do not burn fuel that contains an additive; (such as soybean oil)

- May cause hopper fire
- Damage to product may result

Read the list of ingredients on the packaging. If you are buying wood pellets, the only ingredient listed should be wood fiber or sawdust.

Clinkers

Minerals and other non-combustible materials, like sand, will turn into a hard glass-like substance when heated.

Trees from different areas will vary in mineral content. For this reason, some fuels will produce more clinkers than others.

Moisture

Always burn dry fuel. Burning fuel with high moisture content takes energy to dry and tends to cool the appliance thus, robbing heat from your home. Damp pellet fuel could turn back into sawdust which does not flow properly through the feed system.

Size

- Pellets are either 1/4 inch or 5/16 inch (6-8mm) in diameter
- Length should be no more than 1-1/2 inches (38mm)
- Pellet length can vary from lot to lot from the same manufacturer

Performance

- Higher ash content requires more frequent maintenance.
- “Premium” grade pellets will produce the highest heat output.
- Burning pellets longer than 1-1/2 inches (38mm) can cause inconsistent feeding and/or ignition.

We recommend that you buy fuel in multi-ton lots whenever possible. However, we do recommend trying different brands prior to purchasing multi-ton lots, to ensure your satisfaction.

CAUTION! Tested and approved for use with wood pellets ONLY. Burning of any other fuel will void your warranty.

When changing from “Premium” grade pellets to a “Standard” or “Economy” grade fuel, the FEED ADJUSTER will likely need adjusted to a lower setting. When under maximum demand, ensure there is no unburned fuel being pushed into the ash pan.

Storage

- Wood pellets should be left in their original sealed bag until ready to use, to prevent moisture.
- Do not store fuel within the specified clearance areas, or in a location that will interfere with routine cleaning and maintenance procedures.

CAUTION

Tested and approved for use with wood pellets ONLY. Burning of any other fuel will void your warranty.

NOTICE

Hearth & Home Technologies is not responsible for stove performance or extra maintenance required as a result of using fuel with higher ash or mineral content.

Operation

Power Light

Indicates power to the control board.

Status Light

Will be lit anytime there is a call for heat.

Overheat Safety Zone Light

Indicates elevated boiler water temperature. Power flowing to Overheat circuit.

Combustion Blower Light

Indicates Power to combustion blower

Feed Motor Light Indicates Power to the feed motor.

Igniter Light

Indicates power to the igniter

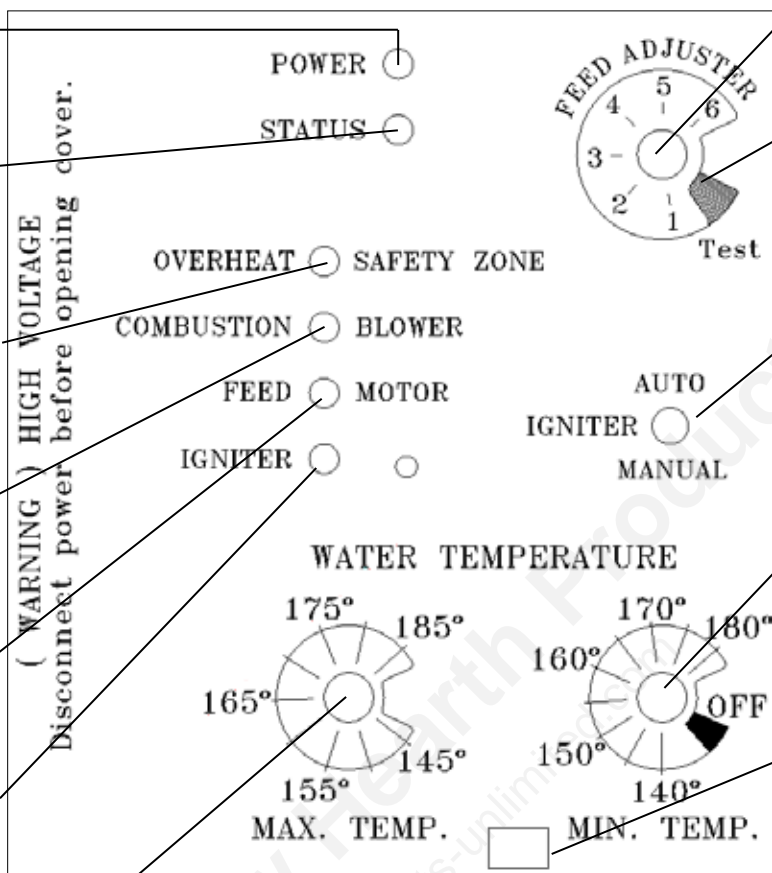

Feed adjuster

Sets the maximum feed rate

Test

Combustion blower, feed motor and safety dump zone are fully energized for the first minute. Afterward, combustion blower remains on low only.

Lighting Mode Selector

Switched between Auto and Manual lighting

Mode Selector/Min Temp Dial

Used to turn the boiler on or off and set the desired minimum operating temperature of the boiler.

Diagnostic Port

For diagnostic purposes only. Requires special DDM monitor supplied to trained technicians exclusively.

Max Temp dial

The "Max Temp Dial" is used to set the desired maximum operating temperature of the boiler.

Status light error messages:

3 Blinks: Indicates that the ESP (Exhaust Sensing Probe) has gone out of range, too many times. May indicate excessive ash build-up in the exhaust stream. If the unit seems to be operating normally, perform a manual reset by cycling the main power off for a few seconds and re-connect.

4 Blinks: Indicates miscommunication with the aquastat, or the sensor is not attached properly. May require a manual reset.

5 Blinks: (In Auto Light Mode Only)

Indicates that the igniter has failed to light the fire after 40 Minutes. To reset - Turn the Mode Selector/Min. Temp. to OFF and then back to the desired temperature.

6 Blinks : Indicates that the control has calculated poor or incomplete combustion occurring for 25 or more minutes. A six blink status may be set if the stove is allowed to run out of pellets. To reset, turn Mode Selector/Min Temp dial to "OFF" then back on to the desired temperature. If the unit was not out of pellets, see Troubleshooting section, Page 34, for more details.

7 Blinks: Boiler water over heat safety shut down. This requires a manual reset by cycling the main power off for a few seconds and re-connect. See explanation on page 20.

Mode Selector/Min. Temp.

Used to turn the boiler on or off and set the desired minimum operating temperature of the boiler.

Max. Temp./ Min. Temp. Water Temperature Settings

See "Setting the boiler temperature" found on page 24.

OFF Mode

Turning the Mode Selector/Min.Temp. to OFF will shut down the boiler.

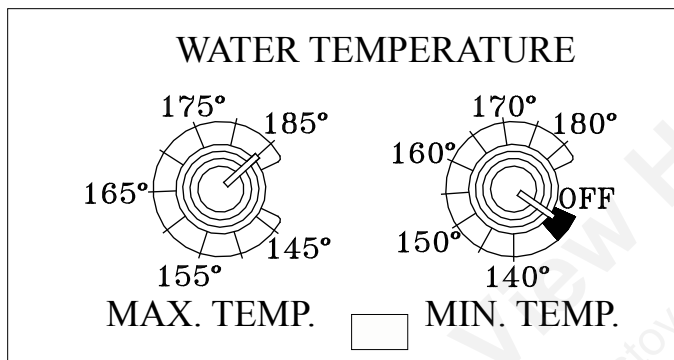
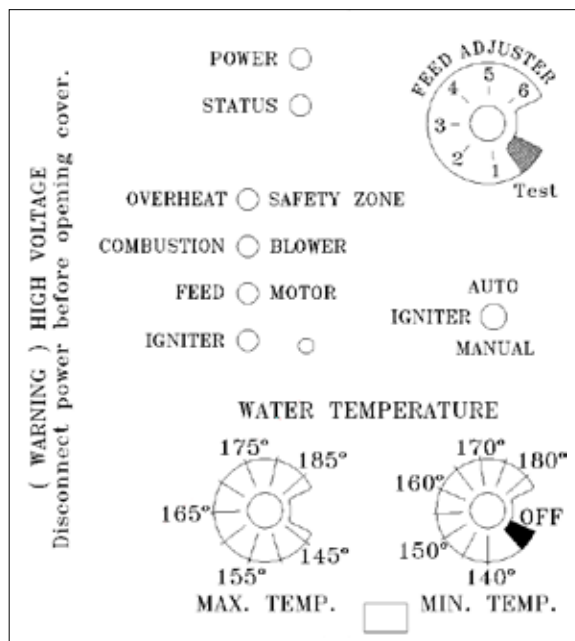

Control Board Operation

Aquastat Sensor - This sensor is located in the aquastat well on the top of the water jacket. This sensor along with the outdoor air sensor is what the control board uses to regulate the feed rate based on these two observed conditions. (Boiler Temp. & Outdoor Air Temperature)

Outdoor Air Temp. Sensor (OAT) - This sensor is located outside the building (on the north side of the house and out of direct sunlight). The Outdoor Air Sensor is used to perform hot water reset based on outdoor air temperatures.

When the OAT sensor is installed, at 20° F. or below (outside temperature), the boiler will operate at the temperature set on the MAX. TEMP. knob. The boiler water temperature will decrease by 1 degree F. for every 1 degree F. in temperature rise (above 20°) of the outdoor air.

NOTE: Pellet Boiler Outdoor Air Reset Operation Graph located on page 25.

Setting The Boiler Temperature

Without the Outdoor Air Temperature Sensor Installed

To set the maximum boiler water temperature, simply turn the Max. Temp. water temperature dial to the desired setting. The control and the boiler will then perform to achieve and maintain the set temperature.

The Min. Temp. Knob is the boiler water temperature minimum, or the lowest temperature the water will go before the unit re-starts. Turning the knob fully counter-clockwise is the “OFF” position, while turning the knob clockwise, past the 140 degree marking, is the “ON” position..

With The Outdoor Air Temp - Sensor Installed

Maximum boiler temp setting is as described above.

The MIN. TEMP. knob in addition to being the mode setting (on or off) now also has the function of setting the minimum boiler water temperature. This would be the lowest boiler water temperature that you want to have based on the following factors.

- 1.) Outdoor Air Temperature (OAT)
- 2.) Domestic Hot Water Use
 - a.) Hot Water Coil Option
 - b.) Indirect Hot Water Storage
- 3.) Overall Volume of the Heating System

The boiler is designed to withstand lower return water temperatures however, extended return temperatures below 140 degrees F can cause condensation in the secondary ash chamber area and also in the venting system, which could cause damage in these areas.

NOTE:

If the system is run at the lower temperature settings, conditions of the firebox, boiler tubes, secondary ash chamber and venting should be monitored closely. If conditions show excess condensation, the boiler water minimum temperature will need to be increased until condensation does not occur. You should also consider some form of tempering of the return water system. Discuss this with your plumber.

Pellet Boiler Outdoor Air Reset Operation

When the outdoor sensor is installed, at 20° F. or below OAT (Outdoor Air Temperature), the boiler will operate at the temperature set on the Maximum Temperature knob. The boiler water temperature will decrease by 1 degree for every 1 degree in temperature rise of the Outside Air.

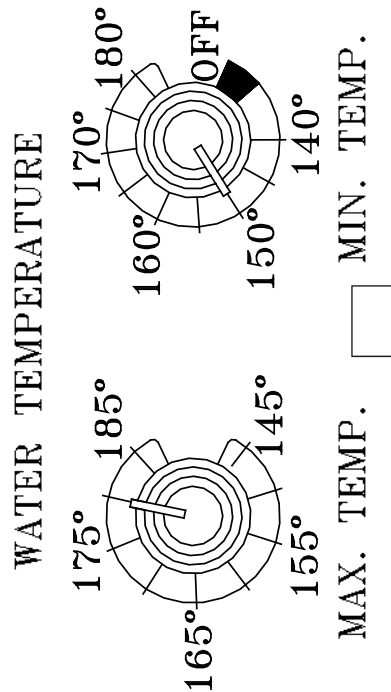
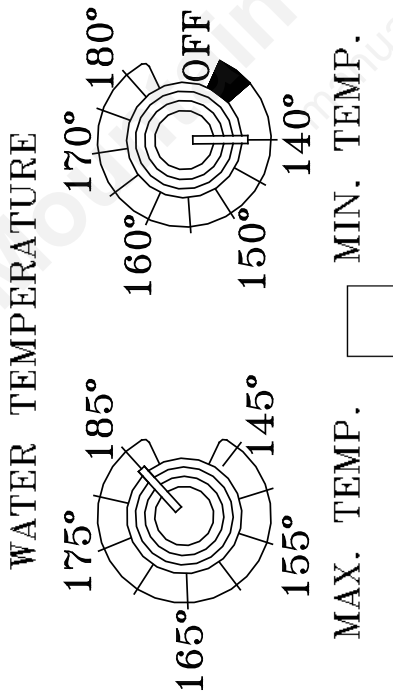

Example 1

	OAT	Water Temp	Degree Change
Max set at 185°	65°	140°	-45°
Min set at 140°	60°	145°	-40°
	55°	150°	-35°
	50°	155°	-30°
	45°	160°	-25°
	40°	165°	-20°
	35°	170°	-15°
	30°	175°	-10°
	25°	180°	-5°
	20°	185°	0°
	15°	185°	0°
	10°	185°	0°
	5°	185°	0°
	0°	185°	0°

Example 2

	OAT	Water Temp	Degree Change
Max set at 180°	65°	150°	*
Min set at 150°	60°	150°	*
	55°	150°	*
	50°	150°	-30°
	45°	155°	-25°
	40°	160°	-20°
	35°	165°	-15°
	30°	170°	-10°
	25°	175°	-5°
	20°	180°	0°
	15°	180°	0°
	10°	180°	0°
	5°	180°	0°
	0°	180°	0°

* No change in boiler temperature after reaching minimum setpoint temperature.

Starting A Fire Automatically

1. Turn Mode Selector to “OFF”.

This resets the control in addition to turning it off.

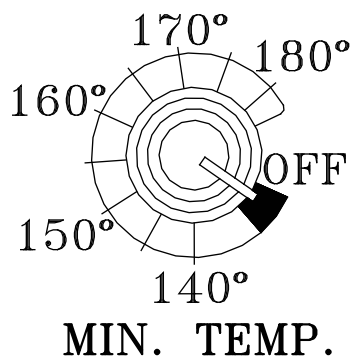

2. Clean Burnpot with scraper, if necessary.

This is usually a weekly maintenance procedure. Cleaning the burn pot with the scraper with a small amount of new fuel in the bottom is not a problem. First, scrape the ashes on the front of the burn pot into the ash pan. Then scrape the hole grid surface downward into the burn pot. When the stove is ignited these scrapings will be pushed out by the feeder.

The illustration at left shows the hopper swing plate open for easy access to the burn pot. The burn pot can also be reached through the firebox door.

NOTE: To minimize the amount of stress placed on the hopper swing plate hinges, opening of the hopper swing plate should be done with the least amount of fuel in the hopper as possible.

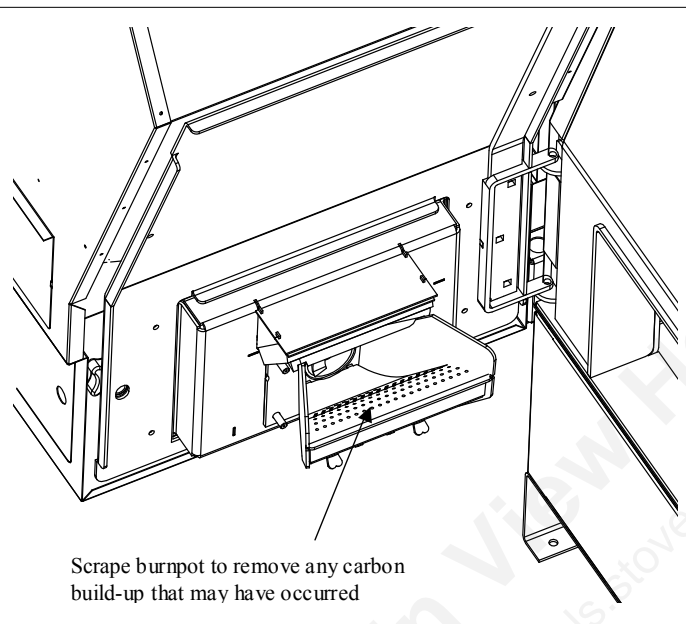

3. Fill Hopper with pellets.

When filling the hopper check for excessive fines in the bottom of the hopper. Fines are small pieces of broken pellets (sawdust). Fines do not flow easily and often build up on the hopper funnel bottom angles. These fines can be pushed into the feeder opening and then fill the hopper with pellets. As the system works, they will be burned.

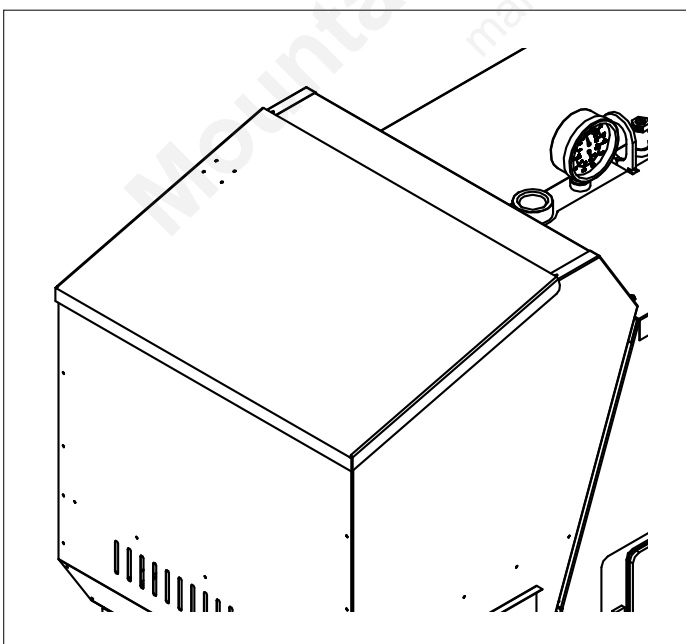

Operation

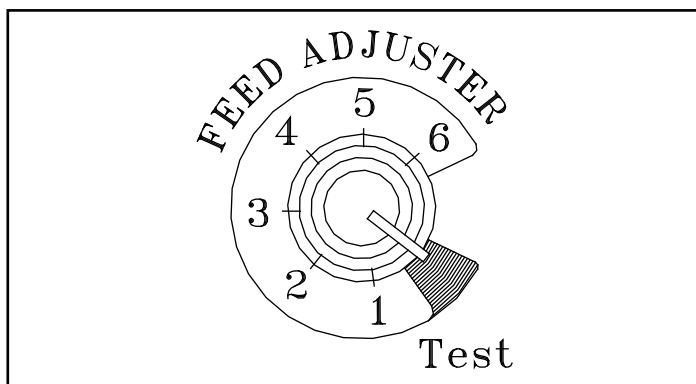

4. If Starting After an Empty Hopper, Turn Feed Adjuster to “TEST” (for one 60 second cycle). This will feed pellets into the auger tube and also allow you to check the motors for operation. **NOTE: The auger motor will not operate with any of the doors open.**

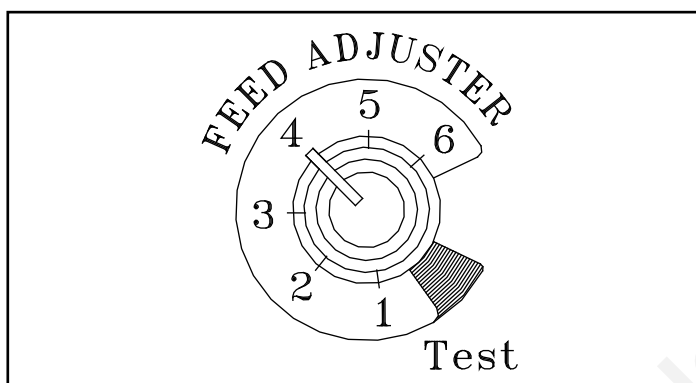

5. Turn Feed Adjuster to #4.

If this is your first fire or you are trying different pellets, set the feed adjuster to #4. This is an average number for most pellets and may need to be adjusted for your particular fuel. After you know a feed rate setting that works well for your application, use that setting.

NOTE: You know your feed rate is too high when: The overheat safety feature is energized each time the heating zone demand turns off during a high burn. OR, If unburned or partially burned pellets are found in the ash pan. (this may also be an indication of a burn pot in need of scraping.)



6. Flip the Igniter Switch up into the “AUTO” position.

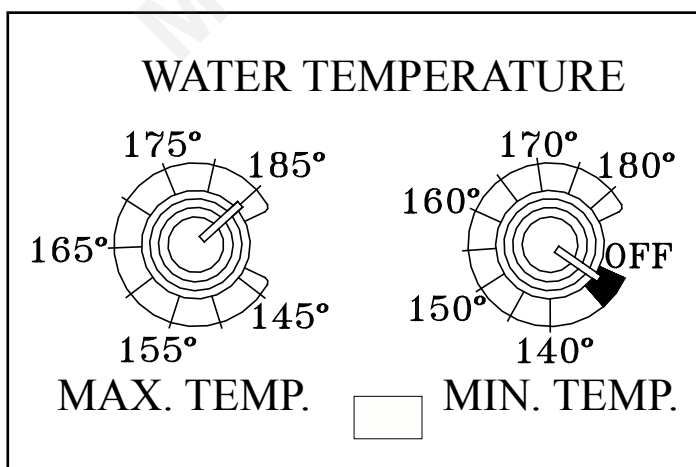

7. Turn the **MAX. TEMP. Dial** on the control board to the desired temperature. This setting must always be at least 5° F. higher than the **MIN. TEMP.** setting.

WARNING: HOT WHILE IN OPERATION. KEEP CHILDREN, CLOTHING, AND FURNITURE AWAY. CONTACT MAY CAUSE SKIN BURNS.

Operation

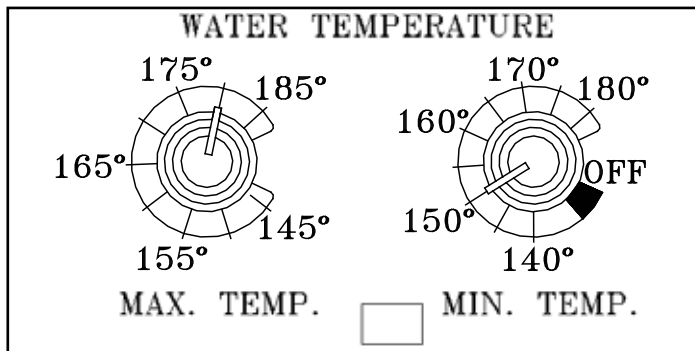

8. Turn the **MIN. TEMP. Dial** on the control board to the desired Minimum temperature. This will start the lighting process if the temperature at the aquastat sensor is approximately 5° F. less than the set temperature on the MAX TEMP dial.

This is more than just an automatic ignition pellet boiler. The automatic system will allow the fire size to be adjusted to match the heating needs and even put the fire out if necessary. If heat is needed after the fire is out, the boiler will automatically re-ignite and adjust the fire size to match the heating need.

9. **Fill hopper** with pellets and **remove ashes** as required.

Type of Fuel

Use pelletized wood only. The lower the ash content of the pellets the less cleaning that will be needed of the heat exchanger surfaces. The cleaner these surfaces are kept, the more efficient the boiler will be.

NOTE: Do not burn garbage, gasoline, naphtha, engine oil, or other inappropriate materials in this unit.

Store pellets in the manufacturer's wrapping until needed to prevent pellets from absorbing moisture. Do not store fuel within the appliance installation clearances, or within the space required for fueling, ash removal, and other routine maintenance operations.

Lighting A Fire Manually

Lighting the fire manually will not be necessary unless the igniter system fails.

Follow steps 1 through 5 of the instructions for automatic lighting.

6. **Flip the Igniter Switch Down** into the "MANUAL-LIGHT" position. See Fig. 12.



Fig. 12

7. **Open hopper swing plate** as shown in Fig. 13 (See "NOTE" on page 26.)

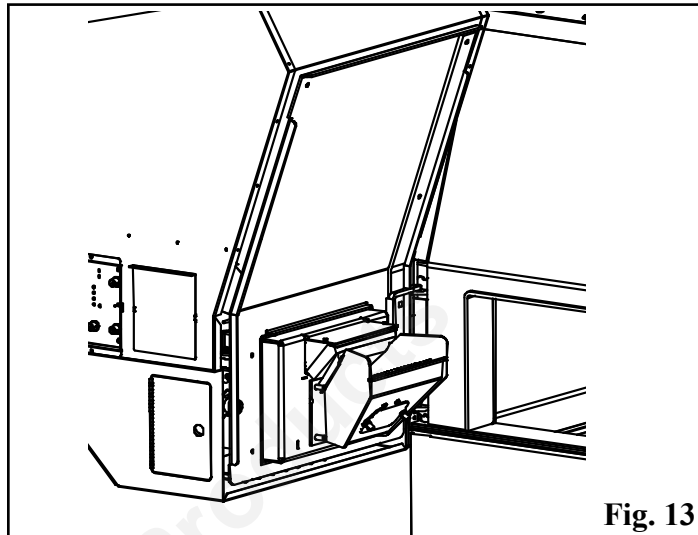

Fig. 13

8. **Fill burnpot with pellets** as shown. See Fig. 14. **Only fill level with the front edge.**

(----- DO NOT OVERFILL -----)

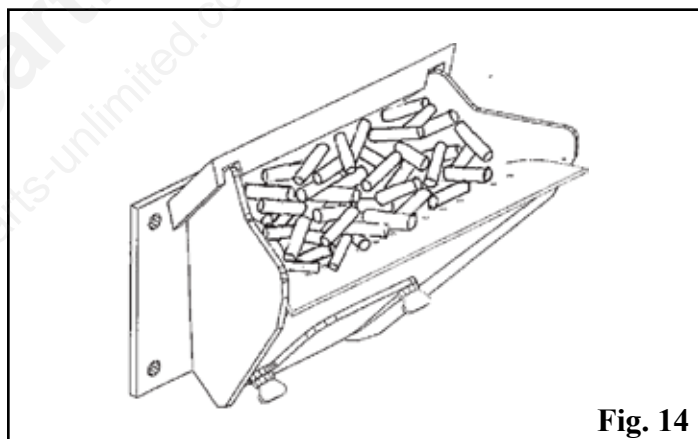

Fig. 14

9. **Have matches or other ignition source ready.**

10. **Turn Mode Selector** to desired MIN TEMP setting.

This will start the combustion blower and allow the ESP to control the fire in relation to the MAX TEMP Dial setting. (The MAX TEMP dial setting must always be set above the MIN TEMP setting) Once the fire is well established the MAX TEMP dial can remain on any temperature setting desired.

NOTE: When the Switch is set to Manual ignite position the boiler will function as in auto ignite except the fire will not be allowed to go out. It will only be allowed to go to a minimum burn rate between the times the aquastat is calling for heat. This rate is about 1.1 pound of fuel per hour. If used in the Manual ignite mode, be sure there is an overheat dump zone in place. Note that if the dump zone does not provide sufficient cooling, and the water temperature continues rising, the feed motor will be forced to shut off. Because the unit is in Manual Ignite mode, it will not re-ignite when the water temperature cools below the control settings.

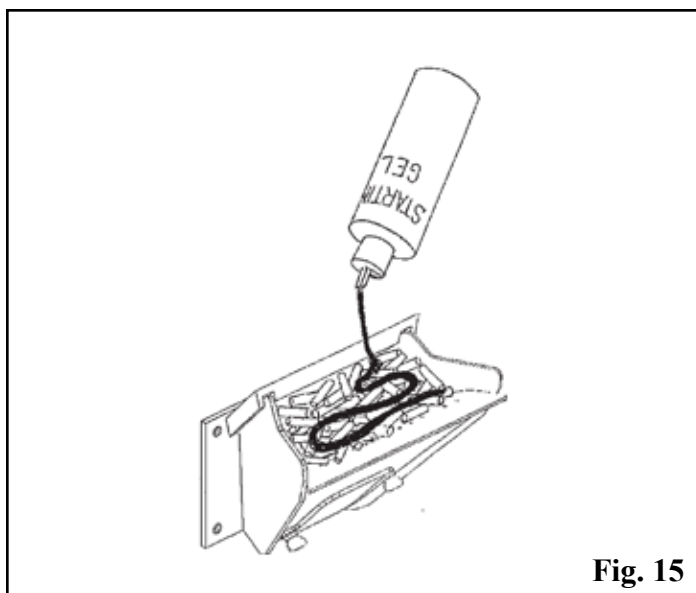

Fig. 15

NOTE: Stirring the starting gel into the pellets usually allows the fire to become established quicker.

CAUTION: A vapor flash could occur if too much time is allowed to pass before lighting the starting gel.

CAUTION: Care must be taken not to get starting gel on your hands or clothing. Serious burns could occur during the lighting process.

CAUTION: Never try to apply more starting gel to an already burning fire, or a fire with smoldering pellets.

“NEVER USE GASOLINE, GASOLINE-TYPE LANTERN FUEL, KEROSENE, CHARCOAL LIGHTER FLUID, OR SIMILAR LIQUIDS TO START OR “FRESHEN UP “ A FIRE IN THIS APPLIANCE. KEEP ALL SUCH LIQUIDS WELL AWAY FROM THE UNIT WHILE IN USE”.

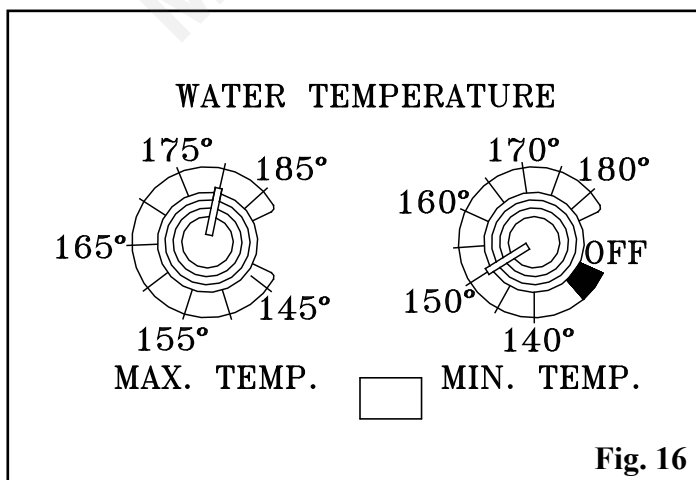

Fig. 16

11. Apply starting gel as shown in Fig.15



12. Light The Starting Gel With A Match.

13. Close The Doors

The fire will light and the control will adjust the fire to the proper level according to the MAX TEMP dial setting.

NOTICE: When burning the boiler in the manual ignition mode, there must be an overheat dump zone incorporated into the plumbing system.

If heating demand stops during manual operation, the control will take the unit to low burn. If no heat is used during this time, the water temperature will continue to rise. When the temperature gets too high, the feeder will be turned off and the fire will go out. This will require a manual re-start of the system. (see page 23 “7 Blinks”)

Solid-fuel burning appliances need to be cleaned frequently because soot, creosote, and ash may accumulate. **If you suspect a chimney/vent pipe fire do the following:**

1. Call the fire department.
2. Remove fuel from the burn pot using the burnpot scraping tool to scrape the pellets into the ash pan.
3. Remove the ash pan from the unit and take outside. Do not place ash pan on a combustible material.
4. Turn off circuit breaker at unit.
5. Do not use the unit until a qualified person has inspected your appliance and venting.

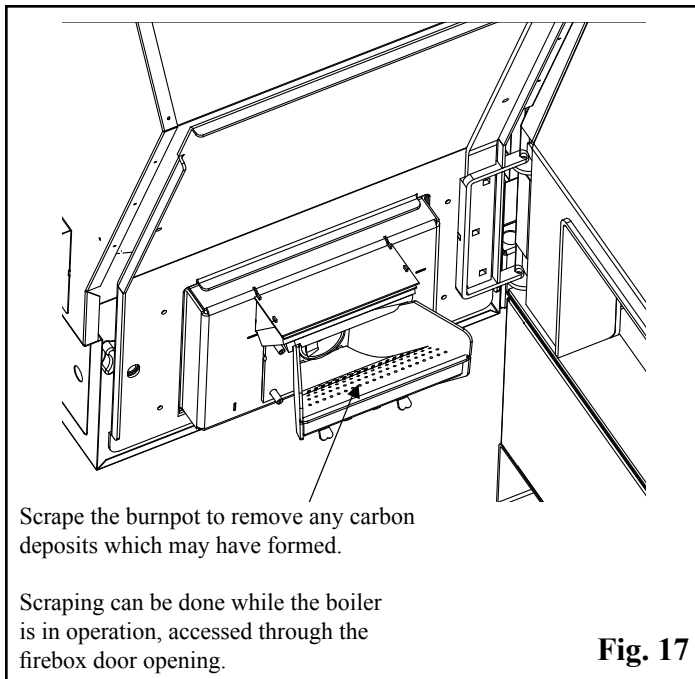

Burnpot Cleaning:

The burnpot should be cleaned no less than once a week. For best operation the burnpot should be cleaned every time the hopper is filled with pellets. The fire does not have to be out to scrape the burnpot although it is recommended the boiler be on minimum burn at the time of cleaning.

Note: Scraping can be done while in operation if performed through the firebox door opening. See Fig. 17

Use the flat end of the scraper provided to scrape down over the holed surface of the burnpot grate. See Fig. 18. It is not necessary to clean out the scrapings from this cleaning because they will be pushed out the next time the auger operates.

Note: Make a special effort to scrape the bottom inside corners of the burnpot where the auger tube enters the burnpot. Carbon deposits can build up over time in this area that may cause a restriction to the flow of pellets into the burnpot.

Note: An old long shank screwdriver with the end sharpened is an ideal aid in the removal of these deposits.

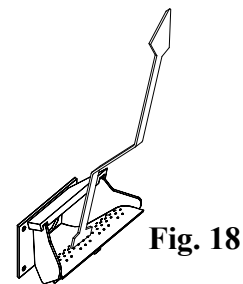
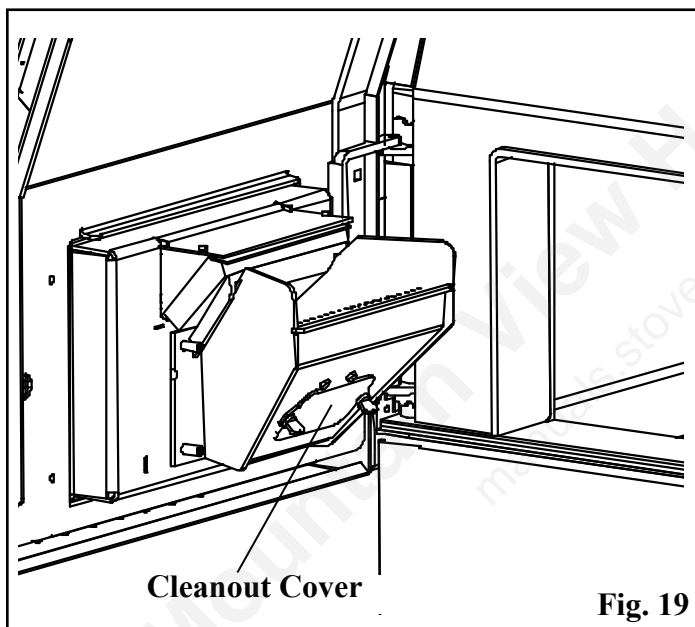

Cleaning the Burnpot Air Chamber:

This area only needs to be cleaned twice a heating season, unless excessive buildup is noticed during scheduled cleanings.

There is a cover on the front of the burnpot to gain access to the air chamber. The cover is held into place by two thumb screws. Loosen the thumb screws and remove the cover. See Fig. 19. The air chamber can be cleaned of any ash that has fallen through the holes during operation and cleaning. Also at this time, remove the feeder assembly cover and remove any fines that may have accumulated.

NOTE: ALWAYS REMEMBER TO CLOSE THE CLEANOUT COVER AFTER CLEANING.

Feeder Chamber (Fig. 20):

This chamber may get a buildup of fines from the feeder mechanism movement. This area should be checked and cleaned at least once a year.

To remove the feeder cover:

- Loosen the 5/16" wing nut.
- Slide the cover off of the threaded stud and lift upward.
- Inspect and clean the inner chamber if necessary. See Fig. 20.
- Reinstall the cover making certain it is centered on the feeder body and hand-tighten the wing nut.

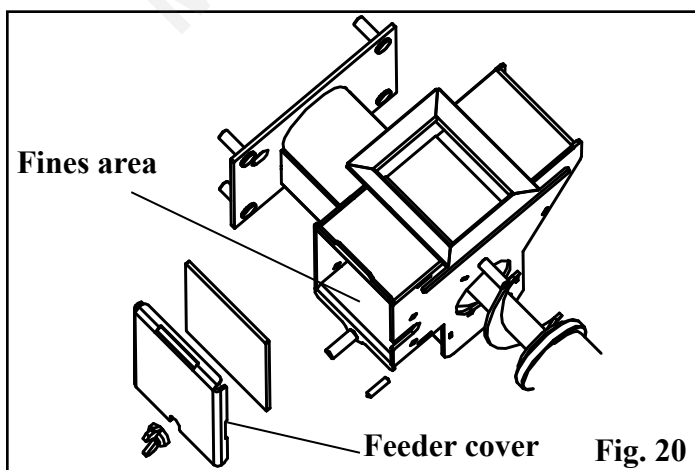

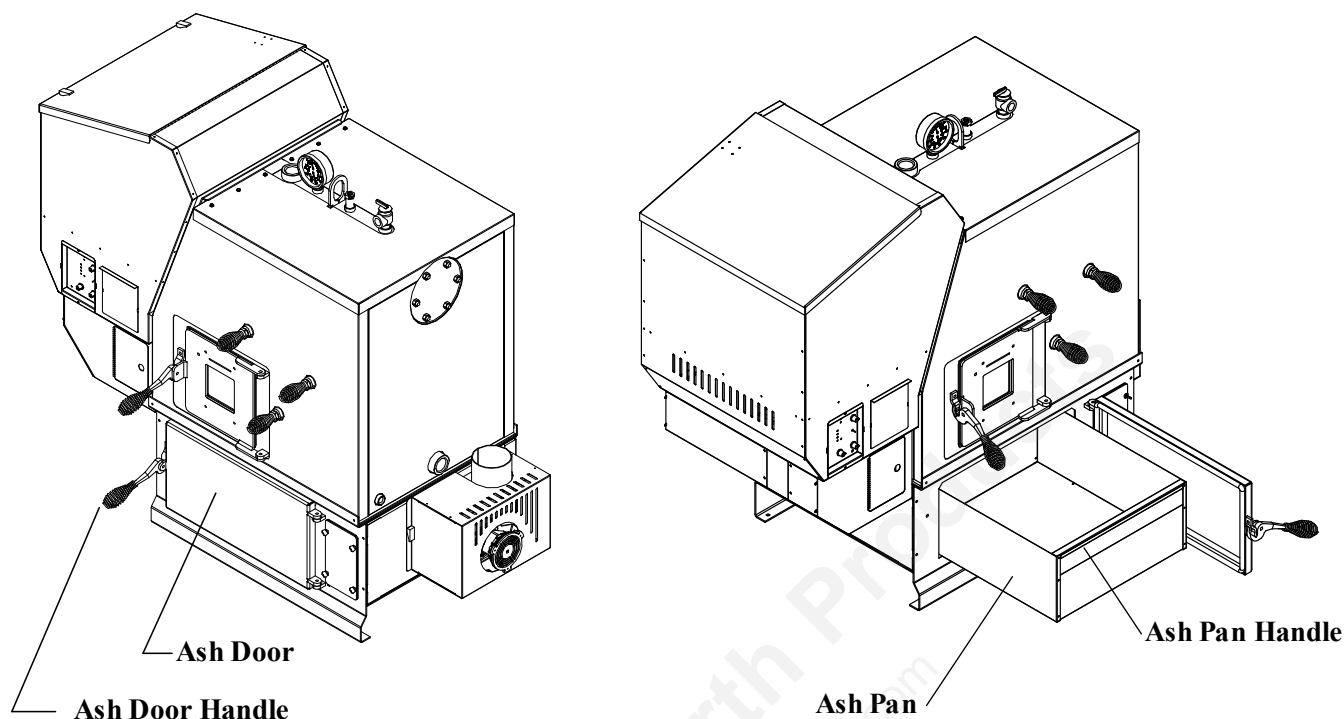

Fig. 21

WARNING! RISK OF FIRE!

- Ash, soot or creosote build-up may cause overheating or fire.
- Routine cleaning of heat exchangers and venting is required.

Ash Removal

It is recommended to remove the ashes when the boiler is not in operation. This lessens the chances of coming in contact with hot surfaces. Ashes can be removed while in operation but, extra care must be taken.

Open Ash Door

Lift the latch and open the door as shown in fig. 21.

NOTE: *Keep hopper lid, hopper swing plate, firebox door and ash pan door closed during operation and maintain all seals in good condition.*

Remove Ash Pan

Always wear gloves to remove ash pan. Grab the ash pan by the finger hold and pull it out of the boiler. Lift the ash pan by the finger hold and use it for carrying the ash pan. **Close the ash door before disposing the ashes.**

Disposal of Ashes

Ashes should be placed in a steel container with a tight fitting lid. The closed container of ashes should be moved outdoors immediately and placed on a non-combustible floor or on the ground, well away from all combustible materials, pending final disposal. If ashes are disposed of by burial in soil or otherwise locally dispersed, they should be retained in the closed container until all cinders have thoroughly cooled. Other waste shall not be placed in this container.

Soot and Flyash: Formation and Need for Removal

The products of combustion will contain small particles of flyash. The flyash will collect in the exhaust venting system and restrict the flow of the flue gases. Incomplete combustion, such as occurs during startup, shutdown, or incorrect operation of the room heater will lead to some soot formation which will collect in the exhaust venting system. The exhaust venting system should be inspected at least twice monthly to determine if cleaning is necessary. Pay particular attention to screening in the vent cap. The screen, if present, will accumulate with ashes rather quickly.

Maintenance

Heat Exchanger Cleanout Rod Handles

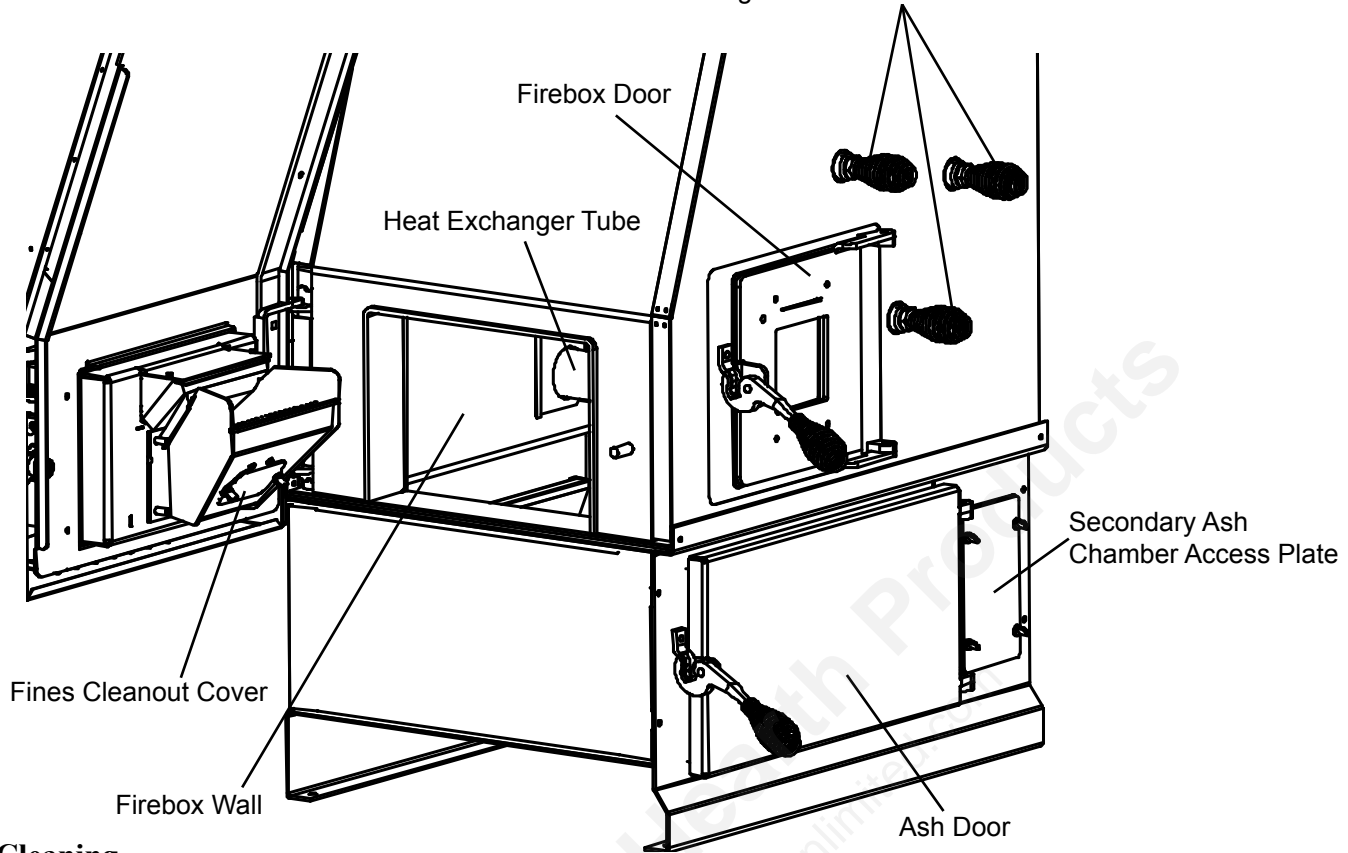

Cleaning

This cleaning should be done after each ton of pellets used. The frequency of this cleaning will be directly related to the quality and the ash content of the pellets being used. Keep in mind that the cleaner the heat exchanger surface is kept, the higher the heat transfer efficiency will be.

Due to its ease of restarting it is recommended that the boiler be **OFF** and **COOL** before cleaning.

Start by actuating the (3) heat exchanger cleanout rods by pulling and pushing these rods vigorously several times. This action will remove any fly ash built up on the heat exchanger tubes. This can also be done at any time during the operation of the boiler to maintain higher efficiencies. Make sure that these rods are pushed in when cleaning is completed.

Cleaning Steps

-Open the hopper swing plate to access burnpot and also the firebox. With a wisp brush, wire brush, stiff bristled paint brush or a soot vac, clean the firebox walls and any fly ash that has accumulated on the ledges of the burnpot, or burnpot opening. At this time you can scrape and clean the burnpot and fines cleanout area.

-Open firebox door and vacuum ash from ledges and ash deflector. You can also clean the firebox door viewing glass using a typical glass cleaner and soft cloth.

-Open the ash door and remove the ash pan. Dispose of any ash that has accumulated in the ash pan as well as any fly ash from within the ash pan area.

-Remove the (4) thumbscrews on the secondary ash chamber access plate and remove it to access the secondary ash chamber. Remove all fly ash from this area. This process should be done as needed.

-Inspect all sealing gaskets to ensure a proper seal and re-install all components removed for cleaning.

CAUTION: Cleanout of the heat exchanger, flue pipe, chimney, and combustion blower fan housing, is especially important at the end of the heating season to minimize corrosion during the summer months, caused by accumulated ash.

NOTE: To minimize the amount of stress placed on the hopper swing plate hinges, opening of the hopper swing plate should be done with the least amount of fuel in the hopper as possible.

Maintenance

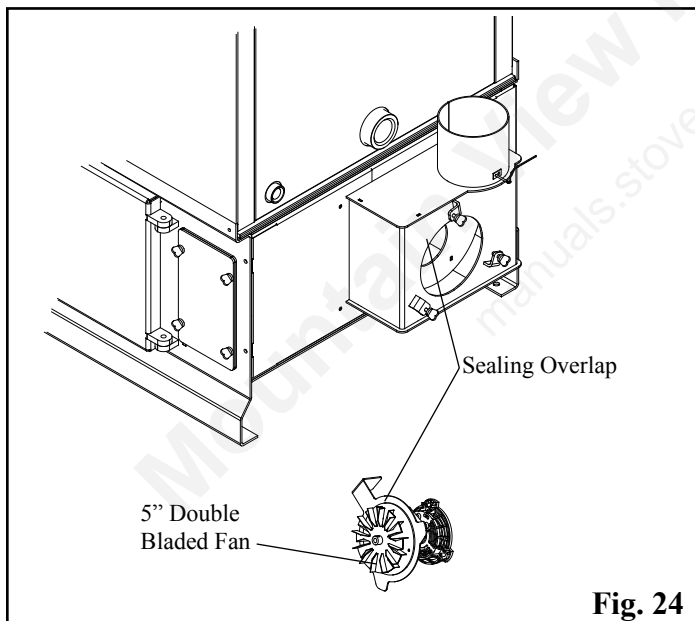
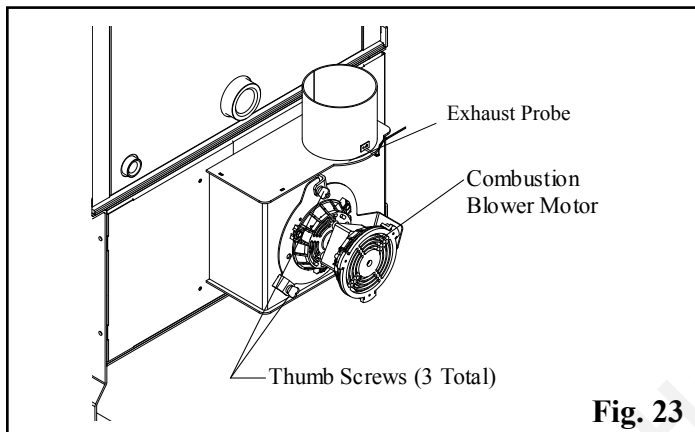
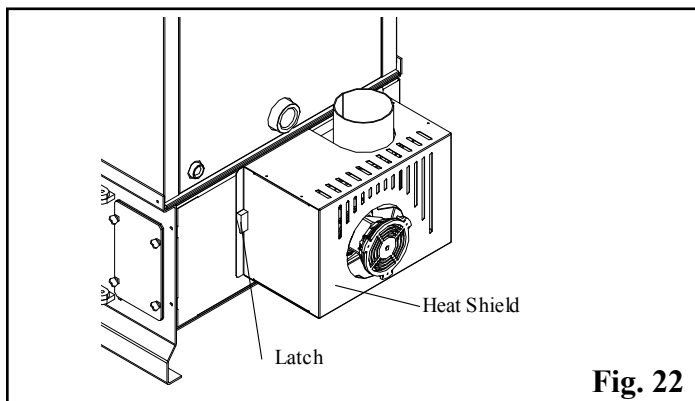

Combustion Blower Cleaning

Remove the combustion blower heat shield. There are two latches that hold the shield in place (See Fig. 22). Flip the latches up and pull the shield away from the boiler. It can not be fully removed, it can only be moved down over the wire until it hangs on the junction box.

The boiler **MUST be OFF and COOL** before you should attempt to clean the combustion blower.

The wire to the combustion blower doesn't need to be disconnected during the cleaning process.

Loosen the three (3) thumb screws about 4 turns each. See Fig. 23. Hold the motor head with one hand and the blower plate handle with the other hand. Pull outward on the plate handle until the complete unit comes loose. Now rotate the plate counter-clockwise about 1/8 turn. This will allow the complete assembly to be removed from the blower chamber.

Clean the blower fan blades and the blower plate sealing overlap. See Fig. 24.

NOTE: Be careful not to bend the fan blades, this will throw the fan blade out of balance or it may rub the inner chamber, which may affect the performance of the boiler. Any horizontal and vertical flue pipe directly above the unit should be cleaned at this time

NOTE: The horizontal flue pipe directly above the boiler is the first place fly ash will settle, due to the slowing of flue gas velocity through horizontal pipe. Cleaning of horizontal venting pipes is very important to the efficiency of this boiler.

Clean the flue outlet throat as well as the inner chamber of the flue tunnel (this is the hole that goes up into the flue pipe). See Fig. 24.

NOTE: The exhaust probe sensing tip extends into this same area. **CARE MUST BE TAKEN NOT TO DAMAGE THE ESP DURING CLEANING.** Bending of the ESP will make it difficult to remove if it should become necessary. See Fig. 23.

Clean the boiler blower plate, sealing overlap. See Fig 24. Make sure there are no fly ash buildups that may block the easy flow of flue gasses into the combustion blower inlet hole. (A flashlight may be necessary.)

Cleaning the Tube Heat Exchangers:

Three external cleaning rods allow scraping of the heat exchange tubes with a simple in-and-out motion. See picture on page 32.

This cleaning should be done at least once a week, however it can be done more often as desired. The cleaner the heat exchangers are, the more efficient the boiler will be. It is best to perform during a low fire period or when the fire is out. During high fire periods, the cleaning rods may stick due to heat related expansion.

CAUTION: Inspect flue pipes, flue pipe joints and flue pipe seals regularly to ensure that smoke and flue gases are not entering the home.

Troubleshooting

FEEDER DOES NOT FEED

1. No pellets in hopper.
2. Firebox draft may be too low for low draft pressure switch in feeder circuit to operate. **Check for improperly closed doors**, loose or missing gasket on doors or hopper lid, or a faulty pressure switch.
3. Feed motor will not run until the ESP senses 170 deg. F. Maybe you did not put enough pellets in the burn pot before lighting the fire manually.
4. Something is restricting flow in the hopper or causing the slide plate to stick.
5. Feed motor has failed.

PARTIALLY BURNED PELLETS

1. Feed rate too high.
2. Draft too low. (Check burn pot clean-out slide and door gasket).
3. Burn pot or heat exchanger tubes may need to be cleaned.
4. Combination of all the above.
5. #6 status blink: A 6 blink control board status indication is caused by poor or incomplete combustion. The Automatic Ignition circuit board has the ability to track the combustion through feed settings and ESP temperatures. When the control board has calculated poor or incomplete combustion, it will shut down the unit as a safety feature. (Poor or incomplete combustion is a contributor of creosote which may cause a chimney fire)
A 6 blink status may be caused by several things:
 1. Blocked or partially blocked flue.
 2. Blocked or partially blocked inlet air.
 - a. Backdraft damper on the inlet pipe may be stuck closed.
 - b. If outside air is installed, the inlet cover may be blocked.
 3. The air chamber under the burnpot may be filled with fines and small bits of ash.
 4. The holes in the burnpot may be getting filled with ash or carbon buildup.
 5. Combustion blower fan blades may need cleaned.
 6. There is no fuel in the hopper.

SMOKE SMELL

Seal the vent pipe joints and connection to stove with silicone.

FIRE HAS GONE OUT

1. No pellets in hopper.
2. Draft setting is too low.
3. Something is restricting fuel flow.
4. Feed motor or combustion blower has failed.
5. Power failure or blown fuse.

SMOKE IS VISIBLE COMING OUT OF VENT

1. Air-fuel ratio is too rich.
 - A. Feed rate too high.
 - B. Draft too low caused by a gasket leak.

LOW HEAT OUTPUT

1. Feed rate too low
2. Draft too low because of gasket leak.
3. Poor quality or damp pellets
4. Combination of 1 and 2.

Helpful Hints

Cleaning Burn Pot

Whenever your boiler is not burning, take the opportunity to scrape the burn pot to remove carbon buildup. A vacuum cleaner is handy to remove the residue. **Be sure the boiler is cold if you use a vacuum.**

Carbon buildup can be scraped loose with the fire burning using the special tool provided with your stove. Scrape the floor and sides of the burn pot. The carbon will be pushed out by the incoming fuel. Always wear gloves to do this.

Removing Ashes

Ashes can be removed while in operation, but extra care must be taken and always wear gloves.

Maximum Feed Adjuster settings are not needed in most cases. Operating in the normal range (#4) is recommended when maximum heat output is not required. The ESP prevents the stove from being over-fired.

Keep the boiler free of dust and dirt.

Fuel

Pellet fuels are put into 3 categories in terms of ash content. Premium at 1% or less, Standard at 3% or less and all others at 3% or more.

This unit is capable of burning all 3 categories of pellets due to a patented feeder and burn pot system.

It should be noted, however, that higher ash content will require more frequent ash removal, scraping of the burn pot, and may provide less BTU's per pound. Normally, standard and high ash pellets cost less than premium pellets and can be cost effective when burned in this boiler.

The moisture content must not exceed 8%. Higher moisture will rob BTU's and may not burn properly.

Atmospheric Conversion

Atmospheric Conversion: Item # 1-00-232200, provides automatic fill, and converts the heating system plumbing from pressurized to a zero pressure system. Allows for installation into more places where codes and standards restrict pressurized systems. Note that when using the atmospheric conversion, air bleeders and check valves may actually allow air into the lines. Another reason it is important to have a licensed Plumber involved in each phase of your installation.



When using the atmospheric conversion, the circuit board dipswitch #6 must be in the “ON” position. This will lower the overheat temperature parameters to prevent boiling of the water. Since altitude affects the boiling point, it is also recommended to set #6 to “ON” at elevations above 3000 ft.

1-90-07205

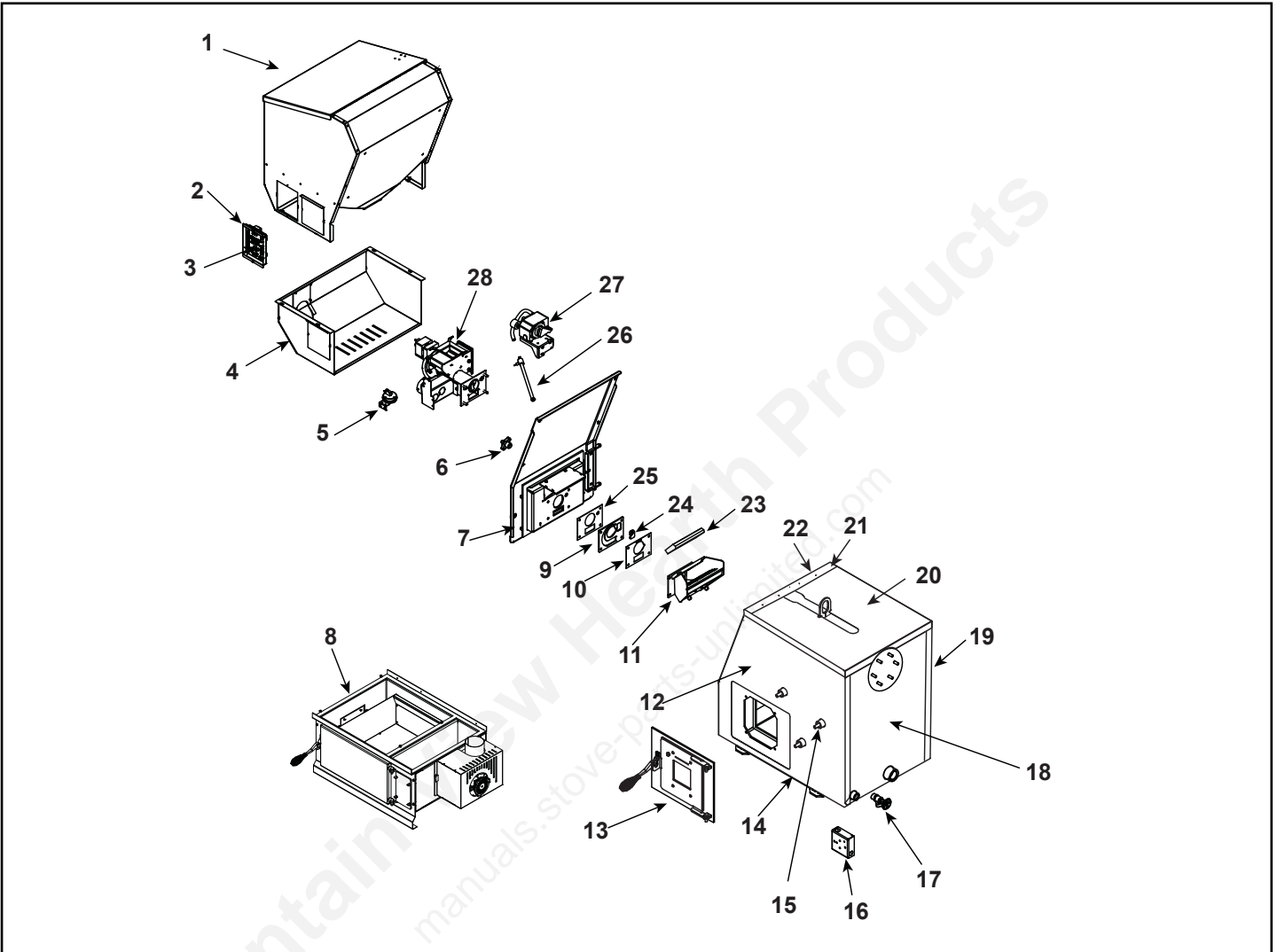

IMPORTANT: THIS IS DATED INFORMATION. When requesting service or replacement parts for your appliance please provide model number and serial number. All parts listed in this manual may be ordered from an authorized dealer.



Stocked at Depot

ITEM	DESCRIPTION	COMMENTS	PART NUMBER	
1	Hopper Assembly		1-10-72140A	
	Gasket, Hopper Throat		3-44-677185	Y
	Hopper Lid Spring Latch		3-31-00927	Y
2	Control Board Plate, Studded w/label		1-10-09330	
3	Control Board		1-00-06143	Y
	Control Knob/Shaft	25 Sets	1-00-015605	Y
	Fuse, 6 AMP	Pkg of 5	3-20-49447-5	Y
4	Feeder Cover Assembly		2-00-72158B	
5	Differential Switch		3-20-6866	Y
6	Red Nylon Knob		3-31-72196	
7	Swing Plate Assembly		1-10-72153A	

Additional service part numbers appear on following page.

#8 Ash Base Assembly

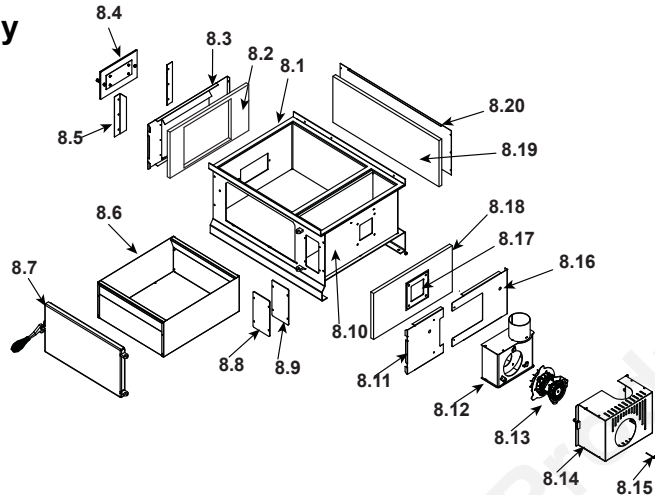

IMPORTANT: THIS IS DATED INFORMATION. When requesting service or replacement parts for your appliance please provide model number and serial number. All parts listed in this manual may be ordered from an authorized dealer.



**Stocked
at Depot**

ITEM	DESCRIPTION	COMMENTS	PART NUMBER	
8.1	Ash Base Gasket	20 Ft	1-00-88250	Y
8.2	Ash Chamber Insul Left Side		3-44-72182	
8.3	Ash Chamber Jacket Left with Relief Hole		2-00-72125B	
8.4	Relief Door/w Pressure Relief	Pre 008340000	1-10-72209	Y
	Relief Door Assembly	Post 008340000	1-10-72204	
	ReliefDamper Gasket		3-44-72206	
8.5	Sheet Metal Bracket	Qty 2 req	2-00-72203B	
8.6	Ash Pan Assembly		1-10-72129	Y
8.7	Ash Door Assembly		1-10-72137A	Y
8.8	Access Plate w/Gasket		2-00-72132	
	Screw, 1/4-20 x 3/4	Pkg of 100	3-30-1112-100	Y
	Wing Nut. 1/4 -20	Pkg of 25	3-30-8011-25	Y
8.9	Access Plate Gasket only		3-44-72207	Y
8.10	Base Weldment		1-10-00250W	
8.11	Ash Chamber Jacket Right, Left of Comb Hole		2-00-72126B	
8.12	Flue Tunnel Weldment		1-10-72145W	Y
8.13	Combustion Blower		3-21-08639	Y
	Blower Mounting Plate		1-10-73416	
	5" Double Blade		3-20-502221	Y
8.14	105 Blower Heat Shield		2-00-72140A	
8.15	ESP Probe		3-20-00844	Y
	ESP Wiring Extension		3-20-72225	Y
8.16	Ash Chamber Jacket Right, Right of Comb Hole		2-00-72127B	
8.17	Combustion Housing Gasket	5 Sets	1-00-07385	Y
8.18	Ash Chamber Insul Right Side		3-44-72183	
8.19	Ash Chamber Insul Back Side		3-44-72184	
8.20	Ash Chamber Jacket Back		2-00-72124B	

Additional service part numbers appear on following page.

IMPORTANT: THIS IS DATED INFORMATION. When requesting service or replacement parts for your appliance please provide model number and serial number. All parts listed in this manual may be ordered from an authorized dealer.



**Stocked
at Depot**

ITEM	DESCRIPTION	COMMENTS	PART NUMBER	
9	Ceramic Insert Plate		2-00-724104	Y
10	Ceramic Insert Gasket		3-44-724114	Y
11	Burn Pot		1-10-73546A	Y
	Clean Out Cover	2 Sets	1-00-06623	Y
	Flame Guide		3-00-08534	Y
	Igniter Cradle Assembly	3 Sets	1-00-06620	Y
	Thumb Screw	Pkg of 10	3-31-782108-10	Y
12	Jacket Side Front		2-00-72173B	
	Water Jacket Insulation Front		3-44-72175	
13	View Door Assembly		1-10-72120S	Y
	Mounting Plate Assembly		1-10-72121A	
	View Door Mounting Plate Gasket	10 Ft	1-00-88100	Y
14	Finished Body Weldment		1-89-07205W	
15	Cleanout Rod	Qty. 3 Req.	2-00-01036	Y
	Cleanout Rod Repair Kit		1-00-72210	
	Scraper Rod Guide	Qty. 3 Req.	3-50-72189	Y
16	4 x 4 Steel Box		3-20-52171	
17	1/2" NPT Boiler Drain	Pre 008341121	3-10-05060	
	3/4" NPT Boiler Drain	Post 008341121	3-10-07560	
18	Jacket Side Right		2-00-72171B	
	Water Jacket Insulation Right		3-44-72177	
19	Jacket Backside		2-00-72174B	
	Water Jacket Insulation Back		3-44-72178	
20	Jacket Top		2-00-72172B	
	Water Jacket Insulation Top		3-44-72179	
21	Jacket Top Angle		2-00-72170B	
22	Water Jacket Insulation Left		3-44-72176	
23	Flame Guide Insulator		3-44-35263	Y
24	Ceramic Insert	Pkg of 10	3-20-05238-10	Y
25	Burn Pot Gasket		3-44-724115	Y
26	306W/120V Igniter	Pre 008341121	3-20-677200	Y
	Tempco 450W Igniter	Post 008341121	3-20-00450	Y
27	Air Pump	Post 008341121	3-20-02679	Y
	Air Pump Filter/Fittings		1-00-02679	Y
	Bracket		2-00-853500B	Y
	Feet	Pkg of 4	3-20-02679-4	

Additional service part numbers appear on following page.

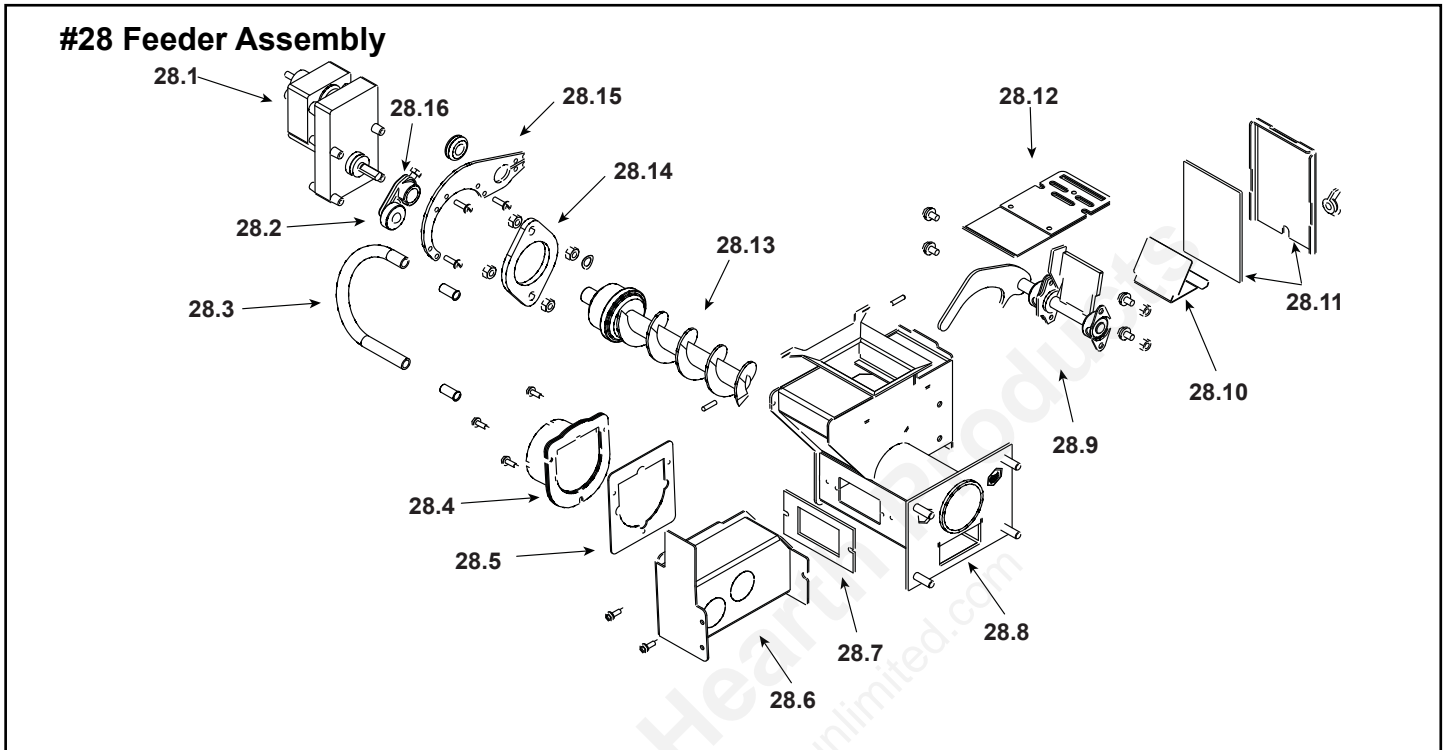

IMPORTANT: THIS IS DATED INFORMATION. When requesting service or replacement parts for your appliance please provide model number and serial number. All parts listed in this manual may be ordered from an authorized dealer.



Stocked at Depot

ITEM	Description	COMMENTS	PART NUMBER	
28.1	6RPM Gear Motor	Pre 008341121	3-20-09302	Y
	Pellet Feeder Gear Motor, 10RPM	Post 008341121	3-20-02524	Y
	Feed Motor Fan Blade	Pkg of 3	3-20-09302-3	Y
28.2	UL Feeder Cam		3-31-3014	Y
28.3	Feeder Crossover Kit		1-00-67900	Y
	9MM Silicone Tube	5 Ft	1-00-511427	Y
28.4	Pellet Air Intake Assembly		1-10-06810A	
28.5	Gasket Feeder Air Intake	Pkg of 6	3-44-72224-6	Y
28.6	UL Feeder Air Intake		1-10-72222	
28.7	Gasket Ultra Air Intake	Pkg of 10	3-44-677160-10	Y
28.8	Ultra Feeder Weldment		1-10-72226S	Y
28.9	UL Feeder Pusher Arm		1-10-677187W	Y
28.10	Fines Deflector	No longer available	2-00-677138-10	
28.11	Gasket, UL Feeder Cover	Set of 2	1-00-677122	Y
28.12	Slide Plate Assembly		1-10-677121A	Y
28.13	UL Feeder Auger Assembly		3-50-00565	Y
28.14	Bearing Flange w/Hardware		1-00-04035	Y
28.15	UL Feeder Gear Motor Bracket w/Grommet		1-00-247406	Y
28.16	UL Feeder Cam Block		3-00-677154	Y

Additional service part numbers appear on following page.

IMPORTANT: THIS IS DATED INFORMATION. When requesting service or replacement parts for your appliance please provide model number and serial number. All parts listed in this manual may be ordered from an authorized dealer.



Stocked at Depot

ITEM	DESCRIPTION	COMMENTS	PART NUMBER	
<div style="display: flex; justify-content: space-between;"> <div style="width: 30%;"> <p>#29 Boiler Kit</p> <p>29.1 </p> <p>29.2 </p> <p>29.3 </p> </div> <div style="width: 30%;"> <p>#30 WaterPlate kit</p> <p>30.1 </p> <p>30.2 </p> <p>30.3 </p> </div> <div style="width: 30%;"> <p>#31 Handle Kit</p> <p>31.1 </p> </div> </div>				
29.1	Press Temp Guage Bottom Mount		3-10-78422	Y
29.2	Immersion Well Wel11A-601R		3-10-935111	Y
29.3	Pressure Relief Valve		3-10-77382	Y
	Boiler Coil assembly		1-00-07006	
	Boiler Coil Washer	Pkg of 2	1-00-07007	
30.1	Water Plate Gasket		3-10-24758	Y
30.2	Steel Water Plate		2-00-01076L	
30.3	7/16-14 Grade 8 Yellow Zinc Finished Hex Nut	Pkg of 25	3-30-8009-25	Y
31.1	Spring Handle .500 Dia	Pkg of 3	3-40-00086-3-3	
	Aqua Temp Sensor		3-20-72180	Y
	Diagnostic Dsplay Module		3-20-05401	Y
	Draft Meter Assembly		1-00-00637	Y
	Rubber Grommet (Hopper Lid)	10 Ft	1-00-00248	Y
	3/8X13/8 RHST RIVET	Pkg of 20	3-30-3020-20	Y
	Door Latch Kit			
	Door Latch with Hardware	2 Sets	1-00-00036	Y
	5/16"-24 Grade 8 Yellow Zinc Finished Hex Nut	Pkg of 50	3-30-8007-50	Y
	5/16"-24 x 3/4" Alloy Steel Black Oxide ButtonHeadCapScrew	Pkg of 50	3-30-3018-50	Y
	Outdoor Air Extension		3-20-72181	
	Outdoor Air Temp Sensor		3-20-72180	Y
	Outdoor Air Wiring- CAT 3 Cable	100 Ft	3-20-02583	
	Wiring Harness	Pre 008341121	3-20-72195	
		Post 008341121	3-20-72230	
Hardware Packages				
	Nut, 1/4"-20 Zinc Plated Finished Hex	Pkg of 100	3-30-8004-100	Y
	Nut, 1/4-20 Zinc Plated Nylon Insert Lock	Pkg of 100	3-30-8022-100	Y
	Nut, 5/16"-18 Grade 8 Yellow Zinc Finished Hex	Pkg of 100	3-30-8006-100	Y
	Screw, #8-18 x 1/2" Hex Washer Head Self Drilling Zinc #2 Pt.	Pkg of 100	3-30-5002-100	Y
	Screw, 1/4-20 x 1" Grade 5 Zinc Plated Hex Cap	Pkg of 50	3-30-1115-50	Y
	Washer, 1/4" Zinc Plated Split Lock	Pkg of 100	3-30-0100-100	Y
	Washer, 5/16" Zinc Plated External Lock	Pkg of 100	3-30-0303-100	Y
	Washer, #10-16 x 3/4" Hex Head TEKS 3 SDS Climaseal Plated	Pkg of 100	3-30-5004-100	Y
	Wingscrew with Collar, 1/4-20 x 1-1/2"	Pkg of 10	3-31-782124-10	Y

Specifications

BTU Input Range= 0, and 9350 to 113,900*

0 BTU if system is satisfied.

Min. Burn = 1.1 pound per hour

Max. Burn = 13.4 pounds per hour

* 8500 BTU per pound figures

Electrical 120 VAC 60 Hz

Combustion blower

Auger motor

Igniter element

Control board

Approximate operating wattage

1.4 AMP

.7 AMP

3.6 AMP

.05 AMP

2 KWH

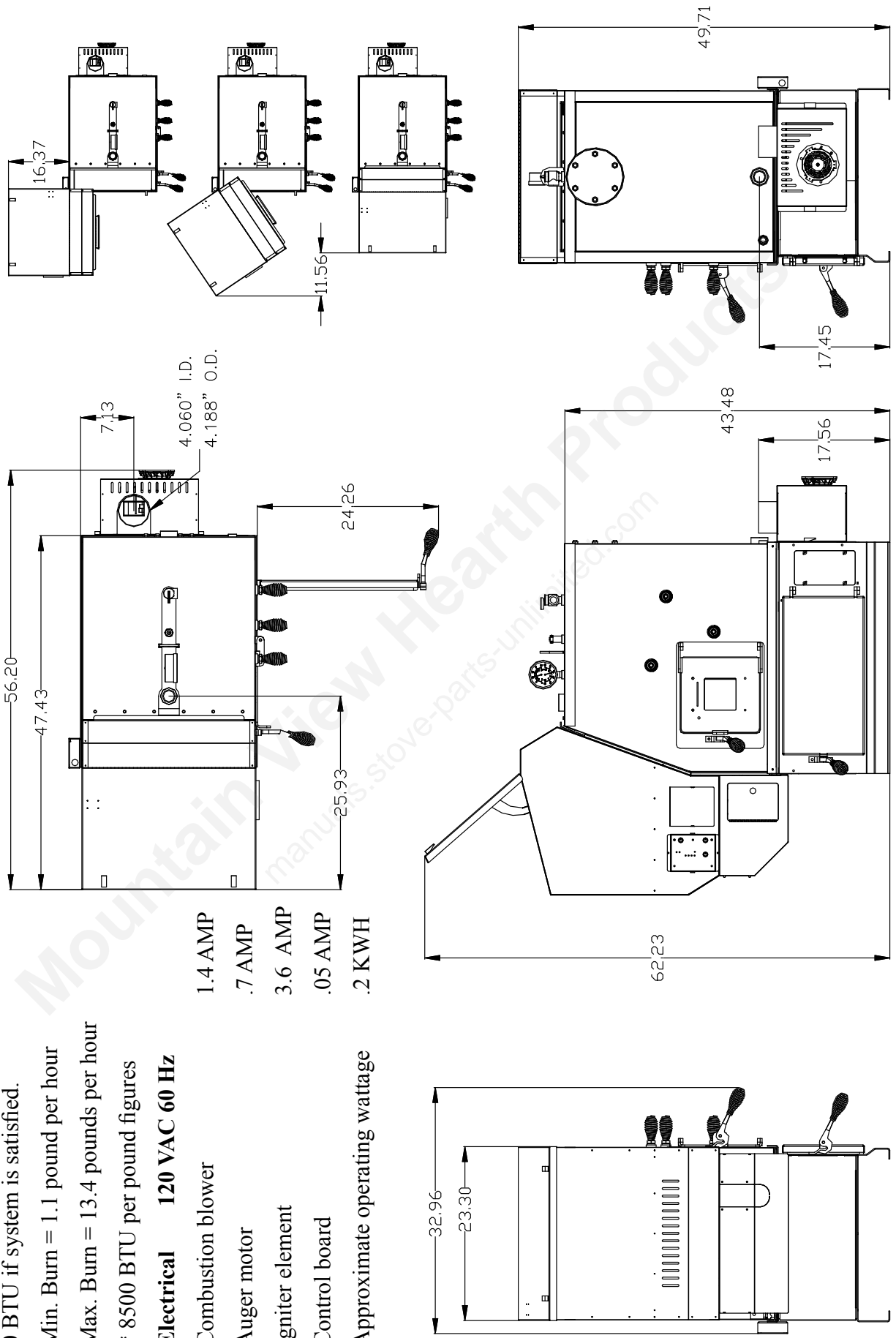

Wiring Diagram

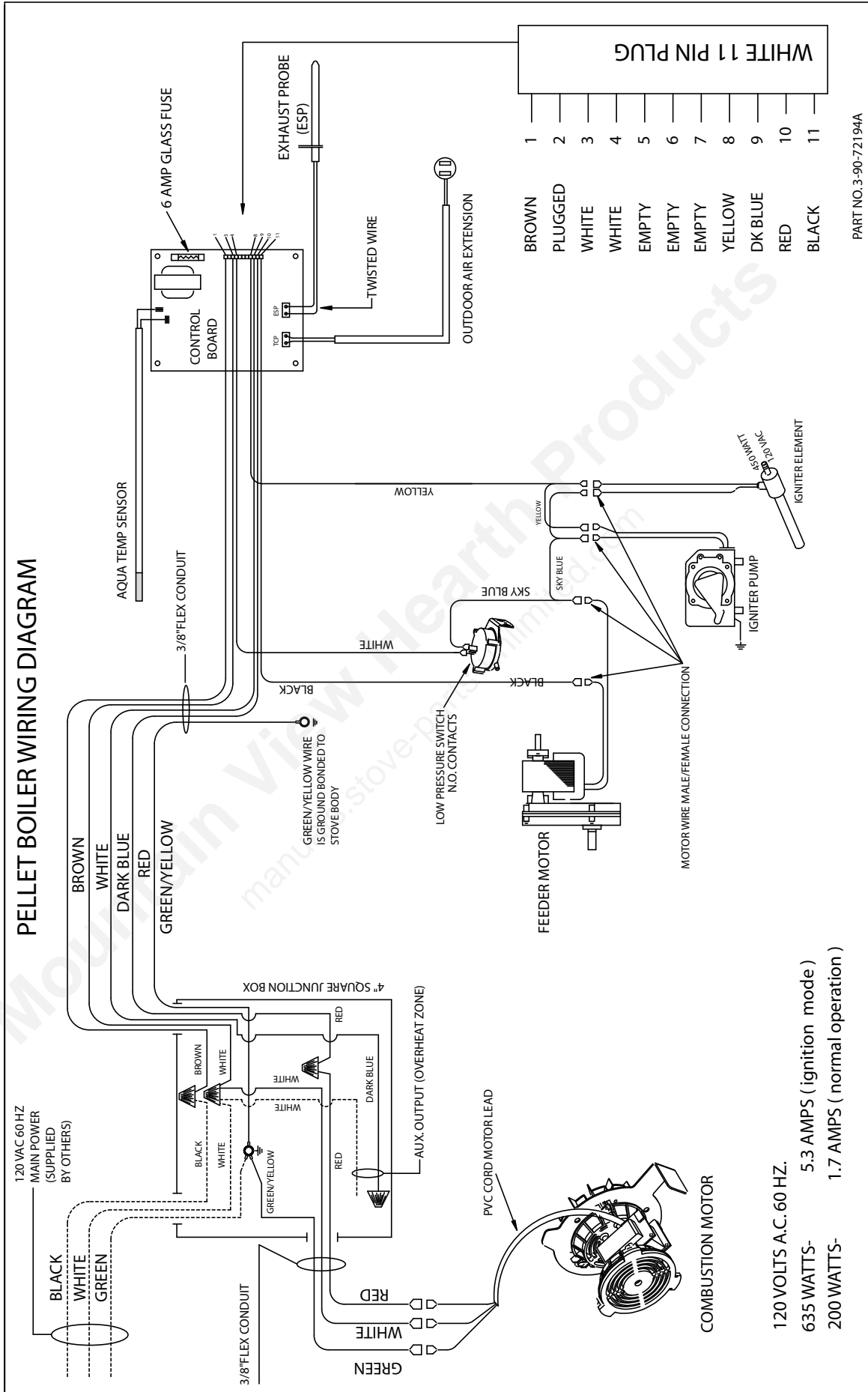

Power Failure Backup Supply

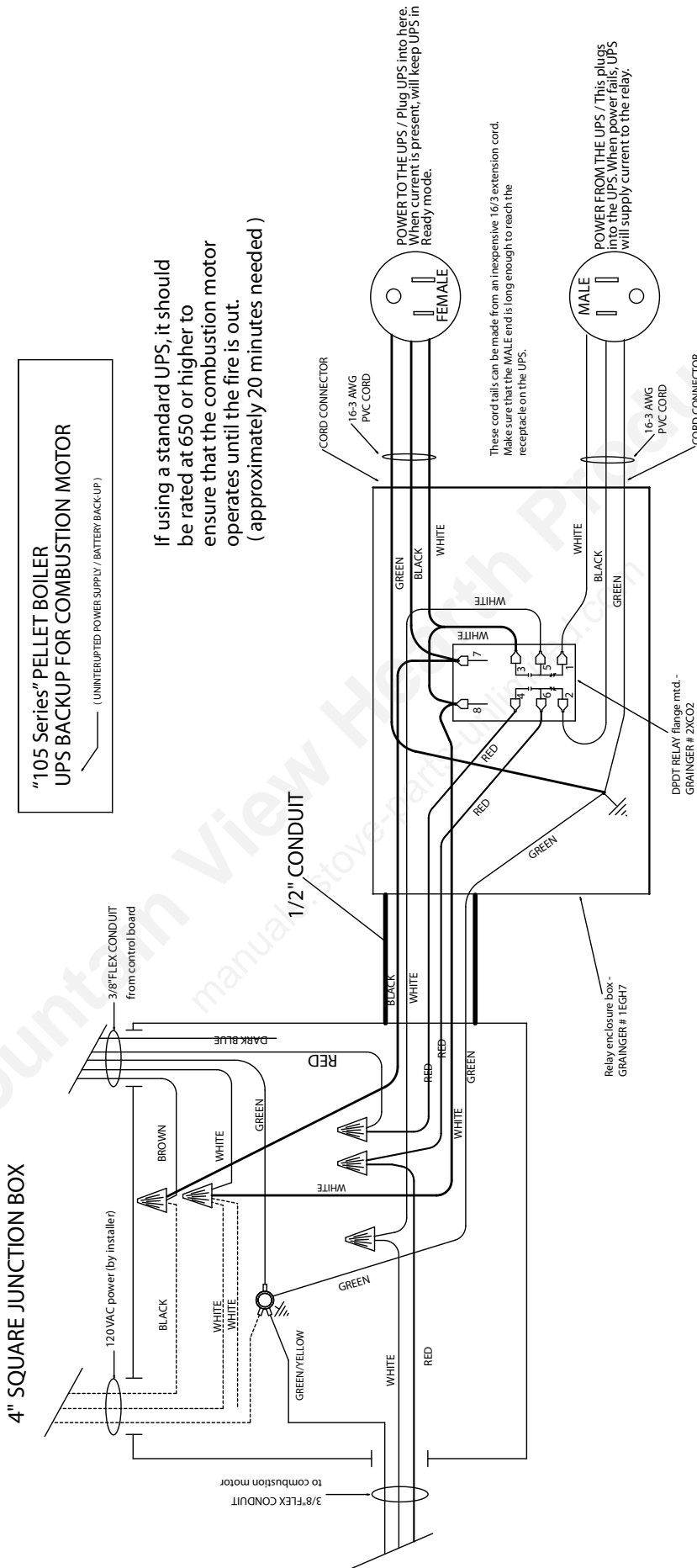

Testing Label

Tested & Listed By  Portland Oregon USA

OMNI-Test Laboratories, Inc.
Report #/Rapport #135-S-16-6
Certified for U.S.A. and Canada
Certifié pour les États-Unis et le Canada

Tested June 2006 to CAN/CSA B366.1-M91 & UL 391.

Install and use only in accordance with the manufacturer's installation/operating instructions. Refer to authorities having jurisdiction for proper installation. Contact local building or fire officials about restrictions and installation inspection in your area. If there are no applicable local codes, follow ANSI/NFPA 211 and CAN/CSA B365. Special precautions are required for passing the chimney through a combustible wall or ceiling. Inspect and clean exhaust venting system frequently in accordance with manufacturer's instructions. Use a 4" diameter type "L" or "PL" venting system.

Harman PB-105

LISTED PELLET FUEL CENTRAL OR SUPPLEMENTARY FURNACES FOR RESIDENTIAL USE/

APPAREIL DE CHAUFFAGE CENTRAL OU SUPPLÉMENTAIRE ENREGISTRÉ DE BOULETTES COMBUSTIBLES POUR USAGE DANS LES RÉSIDENCES



Serial No.
N° de série

008

Testé en Juin 2001 à CAN/CSA B366.1-M91, & UL 391.

Installez et utilisez en accord avec les instructions d'installation et d'opération du fabricant. Référez-vous à des professionnels avec autorité dans l'installation. Contactez le bureau de la construction ou le bureau des incendies au sujet des restrictions et de l'inspection d'installation dans votre région. S'il n'y a pas de codes locaux, suivez alors ANSI/NFPA 211 et CAN/CSA B365. Prenez des précautions spéciales lorsque vous passez la cheminée à travers un mur ou un plafond combustible. Inspectez et nettoyez fréquemment le système de ventilation conformément aux instructions du fabricant. Utilisez un système de ventilation de 4" de diamètre.

Model Modèle	Fuel Combustible	Chimney Connector Size Grandeur du Tuyau de Cheminée	BTUH/Kw Input Pellet Rendement des Boulettes BTUH/Kw	Electrical Classification	Overcurrent Protection Protection Maximum du Courant
PB-105	Wood Pellet Boulettes	4"	113,900 BTUH (33.4 Kw)		20 AMP

Clearances to Combustibles/Espaces Libres

Sidewall to Appliance	20" (507 mm)	Paroi à l'Appareil
Backwall to Appliance	6" (152 mm)	Arrière de l'Appareil
Combustibles to Pellet Vent	18" (457 mm)	Combustibles au Conduit de Fumée
Stove Top to Ceiling	36" (914 mm)	Haut du Poêle au Plafond
Alcove Height	48" (1219 mm)	Hauteur de l'Alcôve
Alcove Depth	36" (914 mm)	Profondeur de l'Alcôve
Combustibles from Stove Front	36" (914 mm)	Des Combustibles au Devant du Poêle

Flooring must be a non-combustible material, 18" in front of the appliance, and 18" in front of each loading door. Le plancher de l'espace désigné pour l'installation doit être fait de matière non-combustible, de 18" en avant, et de 8" de chaque côté des portes d'entrée du combustible.

Essential parts and subassemblies provided for field assembly are as follows / Les pièces essentielles et sous-ensembles procurées pour l'assemblage sont les suivantes:

(5) Spring Handle	(1) 100' Sensor Cable / (1) Câble de la Sonde 100'
(1) 1/2" Pipe	(1) Outdoor Air Sensor / (1) Sonde Extérieure
(1) Safety Coupler 3/4"	(1) Flue Tunnel Weldment / (1) Ensemble Mécano-soudé de Sortie des Gaz de Combustion
(1) Plunger de l'Aquastat 1/2"	(1) Combustion Blower Assembly / (1) Ensemble Ventilateur de Combustion
(1) Temperature/Pressure Gauge / (1) Double Indicateur Température/Pression 1/2"	(1) Heat Shield (Combustion Blower) / (1) Carter de Protection du Ventilateur de Combustion

DO NOT CONNECT THIS UNIT TO A CHIMNEY FLUE SERVING ANOTHER APPLIANCE

NE PAS CONNECTER CET APPAREIL À UN TUYAU DE CHEMINÉE SERVANT UN AUTRE APPAREIL

DANGER! Risk of Fire or Explosion – Do not burn garbage, gasoline, naphtha, engine oil, or other inappropriate materials.

DANGER! Risque de feu ou d'explosion. Ne pas brûler des ordures, de l'essence, du pétrole, de l'huile moteur ou autres matériaux inappropriés.

WARNING! Do not operate with fire chamber or ash removal doors open. Do not store fuel or other combustible material within installation clearance area.

ATTENTION! Ne pas opérer si la porte du combustible ou la porte de la cuvette des cendres sont ouvertes. Ne pas placer le combustible et les matières combustibles à l'intérieur de l'espace désignée pour l'installation.

WARNING: Risk of fire - Do not operate with the flue draft exceeding -.9 in Water Column / -224Pa.

ATTENTION: Risque de feu - Ne fonctionnez pas avec l'ébauche de conduite de cheminée excédant -.9" colonne de l'eau / -224Pa.

CAUTION! Hot while in operation. DO NOT touch. Keep children, clothing, furniture and other combustible material out of the installation clearance area.

ATTENTION! Chaud lors de l'opération. NE PAS toucher. Gardez les enfants, les vêtements, les meubles et les matériaux combustibles loin de l'espace désignée pour l'installation.

In the event of loss of electrical power: Consult owner's manual for restarting your furnace after power is restored.

Dans le cas d'un manque d'électricité: Consultez le manuel du propriétaire pour remettre la fournaise en marche lorsque l'électricité est revenue.

Manufactured by/Fabriqué par: **Hearth & Home Technologies, Inc.**
352 Mountain House Rd. • Halifax, PA 17032

Date of Manufacture/Date de Fabrication

2009 2010 2011 Jan Feb Mar Apr May Jun Jul Aug Sep Oct Nov Dec

Made in U.S.A./Fait aux États-Unis Do Not Remove or Cover This Label/Ne pas enlever ou recouvrir cette étiquette

IGN

Mountain View Hearth Products
manuals.stove-parts-unlimited.com

Mountain View Hearth Products
manuals.stove-parts-unlimited.com

Mountain View Hearth Products
manuals.stove-parts-unlimited.com

HARMANTM

BUILT TO A STANDARD, NOT A PRICE

Proudly Printed On 100% Recycled Paper



Quick Reference (Auto-Light)

- 1 Turn Mode Selector to OFF.
- 2 Use heat exchanger cleanout rods to clean the heat exchanger tubes.**
- 3 Scrape the air holes in the burnpot.**
- 4 Fill the hopper with pellets.
- 5 Turn Feed Adjuster to "Test".*
- 6 Check the Combustion Blower and Feeder Motor for operation.*
- 7 Turn Feed Adjuster back to the #4 setting.
- 8 Turn the MAX TEMP dial to the desired temperature.
- 9 Turn MIN TEMP dial to the desired settings.*
- 10 Flip the igniter switch to Auto.*

The boiler will ignite if the temperature of the boiler water is less than the temperature set on MAX TEMP dial..

***See the section on Operation for information about Manual Lighting and Emergency Power.**

****See the section on Maintenance for more details about cleaning.**

