

Installation & Operating Manual

The Harman PC 45 Corn/Pellet/Grain Stove

HARMAN™

BUILT TO A STANDARD, NOT A PRICE

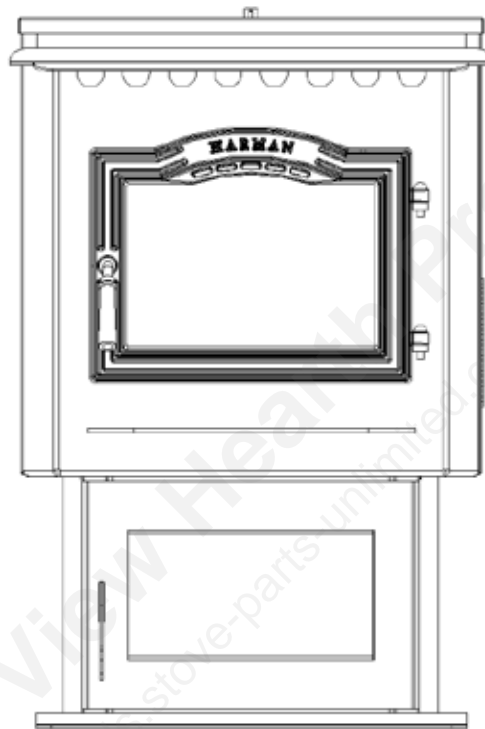

We suggest that our hearth products be installed and serviced by professionals who are certified in the U.S. by the National Fireplace Institute (NFI) as NFI Specialists.



SAFETY NOTICE

PLEASE READ THIS ENTIRE MANUAL BEFORE YOU INSTALL AND USE YOUR NEW ROOM HEATER. FAILURE TO FOLLOW INSTRUCTIONS MAY RESULT IN PROPERTY DAMAGE, BODILY INJURY, OR EVEN DEATH.

FOR USE IN THE U.S. AND CANADA. SUITABLE FOR INSTALLATION IN MOBILE HOMES.

IF THIS APPLIANCE IS NOT PROPERLY INSTALLED, A HOUSE FIRE MAY RESULT. FOR YOUR SAFETY, FOLLOW INSTALLATION DIRECTIONS.

CONTACT LOCAL BUILDING OR FIRE OFFICIALS ABOUT RESTRICTIONS AND INSTALLATION INSPECTION REQUIREMENTS IN YOUR AREA.

CONTACT YOUR LOCAL AUTHORITY (SUCH AS MUNICIPAL BUILDING DEPARTMENT, FIRE DEPARTMENT, FIRE PREVENTION BUREAU, ETC.) TO DETERMINE THE NEED FOR A PERMIT.

CETTE GUIDE D'UTILISATION EST DISPONIBLE EN FRANCAIS. CHEZ VOTRE CONCESSIONNAIRE DE HARMAN HOME HEATING.

SAVE THESE INSTRUCTIONS.

#3-90-02686

Mountain View Hearth Products
manuals.stove-parts-unlimited.com

Assembly and Installation

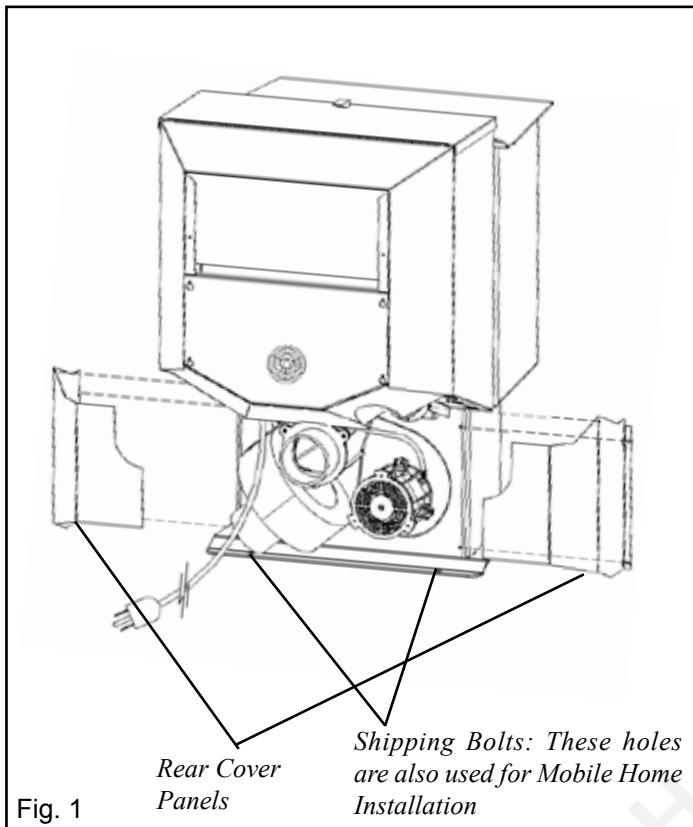

Follow these instructions along with all local codes regarding installation of this appliance.

Do **NOT** use makeshift compromises when installing this appliance, serious consequences may result.

With any hearth appliance, installation of smoke detectors is recommended on every level of the home.

Possible causes of smoke detector activation:

Paint curing process - Open a window near the appliance for the first few hours of burning.

Exhaust being drawn back inside the dwelling - Outside air connection to the appliance is necessary.

Vent leakage - All interior seams and joints should be sealed with silicone where applicable. Follow vent manufacturers instructions for proper sealing.

Unpacking

The PC 45 is bolted to the skid to prevent movement during shipping.

To free the stove from the skid you must remove the hold-down bolts in the rear of the pedestal base.

Removing or Installing rear panels

To remove the rear cover panels, loosen the screws slightly and slide the covers outward as shown in figure 1. To reinstall, simply slide back into place and retighten the screws.

Firebrick

Install the firebrick vertically on the angle above the burnpot.

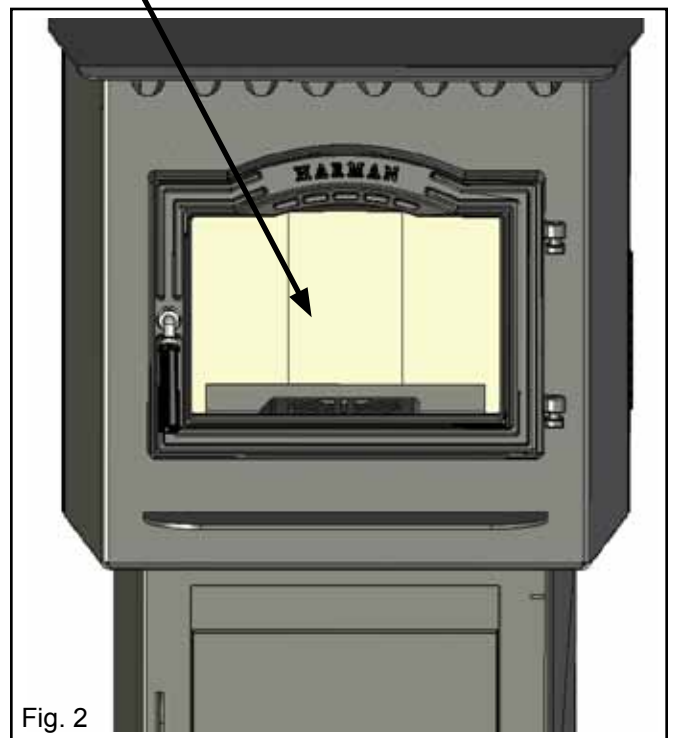

Installation

Location

Place the stove on a noncombustible floor or a floor protector; a minimum of 3/8" material with .84 k value per inch. Floor protection must extend 6 inches to the front, 6 inches to the sides and 1 inch to the rear of the stove. Place the stove away from combustible walls at least as far as shown in figures 3, 4 & 5. Please note the difference in side wall clearance with and without side shields.

Note that the clearances shown are minimum for safety but do not leave much room for access when cleaning or servicing. Please take this into account when placing the stove. **INSTALL VENT AT CLEARANCES SPECIFIED BY THE VENT MANUFACTURER.**

Connect the power cord to a 120 V.A.C. 60Hz grounded receptacle. (A surge protector is recommended to protect the circuit board).

Prior to installing the flue pipe, connect a draft meter to the stove as shown in fig. 6. (The draft meter must have a minimum range of 0"- 0.5"). Turn stove to "TEST" Mode and record the draft reading _____. After the flue pipe is connected, check the draft reading again making sure all doors and windows in the home are closed. If this reading is more than .05" higher than the unconnected reading, check for possible restrictions or the need for outside air. (See page 7). Clearances may only be reduced using methods approved by the regulating authority or NFPA-211.

Mobile Home Installation

When installing this unit in a mobile home several requirements must be followed:

1. The unit must be bolted to the floor. This can be done with 1/4" lag screws through the 2 holes in the base plate.
2. The unit must also be connected to outside air. See page 7.
3. Floor protection and clearances must be followed as shown.
4. Unit must be grounded to the metal frame of the mobile home.

CAUTION: This appliance must be vented to the outside.

Due to high temperatures, the stove should be placed out of traffic and away from furniture and draperies.

Children and adults should be alerted to the hazards of high surface temperatures and should stay away to avoid burn to skin and/or clothing.

Young children should be carefully supervised when they are in the same room as the stove.

Clothing and other flammable materials should not be placed on or near this unit.

Installation and repair of this Harman Stove should be done by a qualified service person. The appliance should be inspected before use and at least annually by a qualified service person. More frequent cleaning will be required. It is imperative that control compartments, burners, and circulating air passageways of the stove be kept clean.

WARNING!- DO NOT INSTALL IN A ROOM DESIGNATED FOR SLEEPING.

CAUTION: THE STRUCTURAL INTEGRITY OF THE MANUFACTURED HOME FLOOR, WALL, AND CEILING/ROOF MUST BE MAINTAINED.

Mobile home installation should be done in accordance with the Manufactured Home and Safety Standard (HUD), CFR 3280, Part 24.

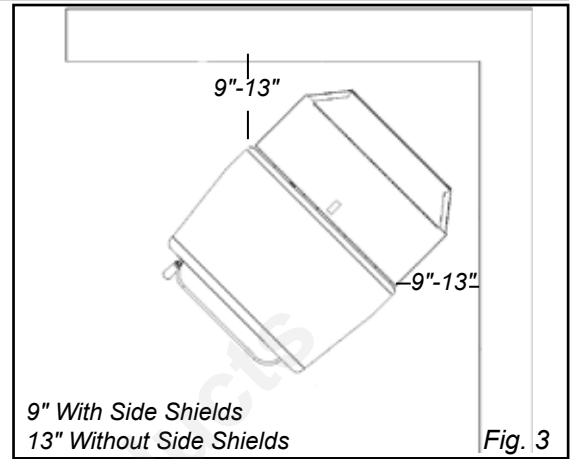

9" With Side Shields
13" Without Side Shields

Fig. 3

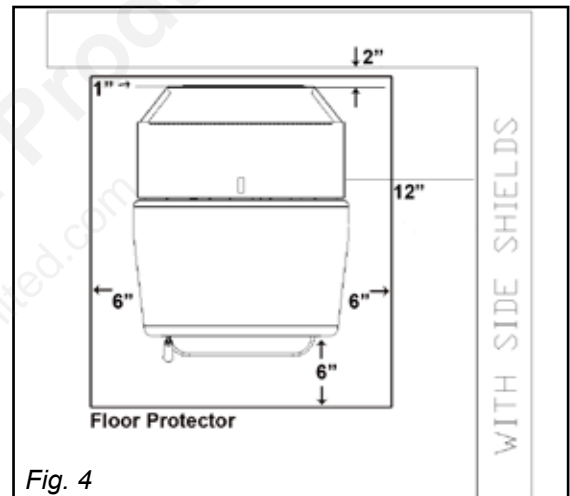

Fig. 4

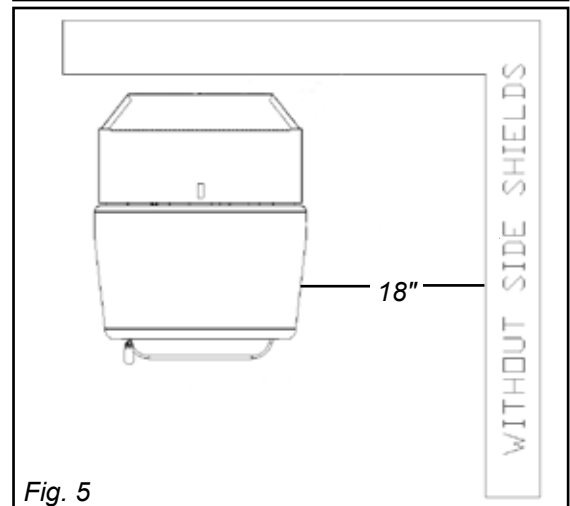

Fig. 5

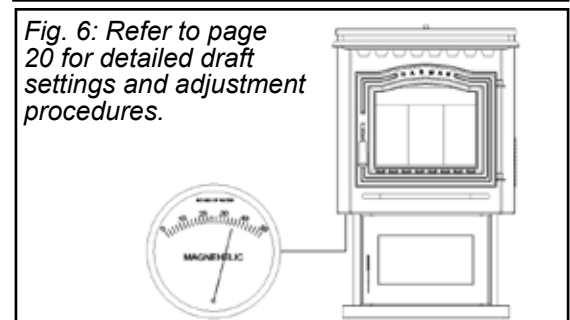
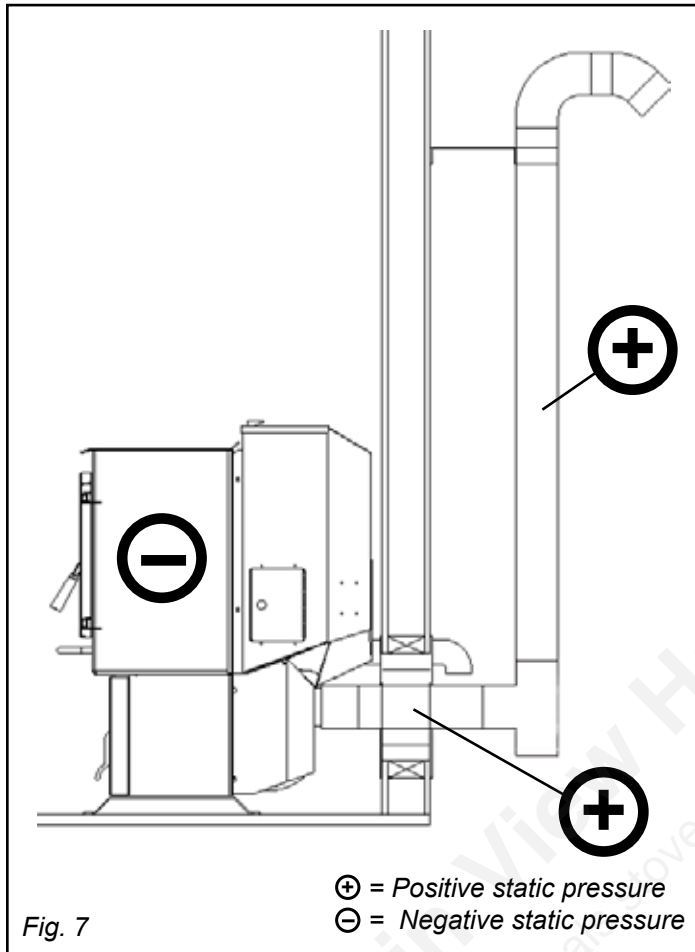

Fig. 6: Refer to page 20 for detailed draft settings and adjustment procedures.

Venting

IMPORTANT NOTICE

Only 3 inch or 4 inch Pellet Vent (PL) Pipe May be used.



A combustion blower is used to extract the combustion gases from the firebox. This causes a negative pressure in the firebox and a positive pressure in the venting system as shown in fig. 7. The longer the vent pipe and more elbows used in the system, the greater the flow resistance. Because of these facts we recommend using as few elbows as possible and 15 feet or less of vent pipe. The maximum horizontal run should not exceed 48". If more than 15 feet of pipe is needed, the diameter should be increased from 3" to 4" because a larger pipe creates less flow resistance. **Be sure to use approved pellet vent pipe wall and ceiling pass through fittings to go through combustible walls and ceilings. The starting collar must be secured to the flue collar with a minimum of two fasteners. Follow vent manufacturer's instructions for sealing each joint and/or seam.**

Vent Pipe

Pellet venting pipe (also known as "PL" vent) is constructed of two layers with air space between the layers. Some manufacturers produce PL vent designed specifically for corn-burning. If planning to burn corn or other grains, be sure venting system is approved and warranted for corn-burning. The sections of pipe lock together to form an air tight seal, however, in some cases a perfect seal is not achieved. For this reason and the fact that the PC45 operates with a positive vent pressure **we recommend that any interior joints also be sealed with silicone.**

Outside Air

Outside air is optional except in mobile homes and where building codes require. The benefit of outside air is mainly noticed in small very tight houses.

To install outside air use 2 3/8" I.D. flex pipe part number 1-00-08543. There is a break-away hole on the rear panel which must be removed before connecting the flex pipe. The pipe should be run outside and terminate 3 feet or more to the side or below the vent pipe outlet. Never terminate the outside air above the vent pipe outlet. The maximum length run of this pipe is 15 feet. If a longer run is needed the size must be increased to 3". Inlet cover part number 1-10-08542 should be used to keep birds, rodents etc. out of pipe.

HRV

When installing in a house with a Heat Reclaiming Ventilation System (HRV) be sure the system is balanced and is not creating a negative pressure in the house.

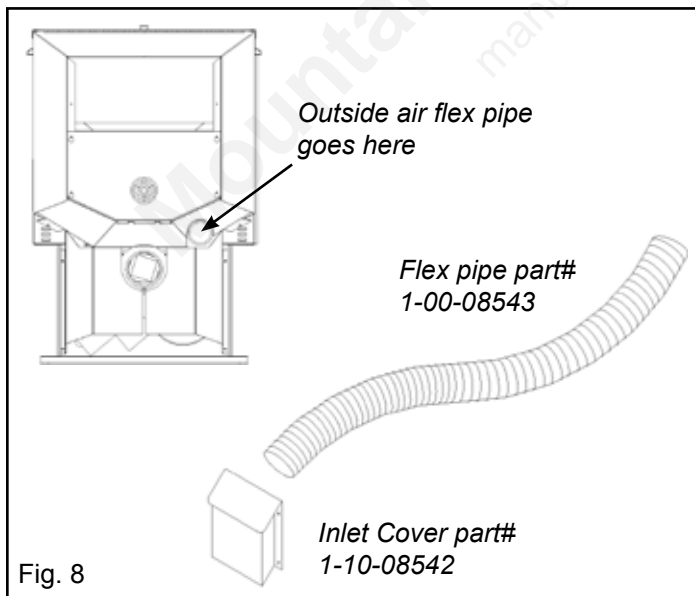

Venting

Avoiding Smoke and Odors

Negative Pressure and Electrical Power Failure:

To reduce the probability of back-drafting or burn back in the appliance during power failure conditions, the appliance must be able to draft naturally, without operation of the combustion blower. Negative pressure in the house may resist this natural draft if not accounted for during the pellet stove installation.

Heat rises in the house, and leaks out at upper levels. This air must be replaced with cold air from outdoors, which flows into lower levels of the house. Vents and chimneys into basements and lower levels of the house can become the conduit for air supply, and reverse under these conditions.

Hearth & Home Technologies recommends the use of outside air in all installations, especially lower level and main floor locations.

Per national building codes, consideration must be given to combustion air supply to all combustion appliances. Failure to supply adequate combustion air for all appliance demands may lead to backdrafting of this and other appliances.

When the appliance is side-wall vented;

The air intake is best located on the same exterior wall as the exhaust vent outlet, and located lower on the wall than the exhaust vent outlet.

When the appliance is roof vented;

The air intake is best located on the exterior wall oriented toward the prevailing wind direction, during the heating season.

The outside air connection will supply all of the demands of the appliance. However, consideration must be given to the total house demand. House demand may consume the air needed for the stove. It may be necessary to add additional ventillation to the space in which the appliance is located. Consult with your local HVAC professional to determine the ventillation demands for your house.

Venting Configurations

To reduce the possibility of reverse drafting during a power failure, Hearth & Home Technologies strongly recommends:

- Installing the vent pipe with a minimum vertical rise of five feet, preferably terminating above the roof line.
- Installing outside air with the intake located below the exhaust termination.

To prevent soot damage to exterior walls of the house, and to prevent re-entry of smoke, soot, or ash into the house:

- Maintain specified clearances to windows, doors, and other air inlets, including air conditioners.
- Vents should not be placed below ventilated soffits. Whenever possible, run the venting above the roof line.
- Avoid terminating the vent in an alcove location.
- Vents should not terminate under overhangs, decks or onto covered porches.
- Maintain a minimum clearance of 12" from the vent termination to the exterior wall. If you see deposits developing on the wall, you may need to extend this distance to accommodate your installation conditions.

Optional Battery Back-Up

Hearth & Home Technologies supplies an optional battery back up system to operate the appliance during a loss of electrical power. Whether you experience frequent power failures or not, this back up system is recommended.

Hearth & Home Technologies assumes no responsibility for, nor does the warranty extend to, smoke damage caused by reverse drafting of appliances during a power failure condition.

Venting

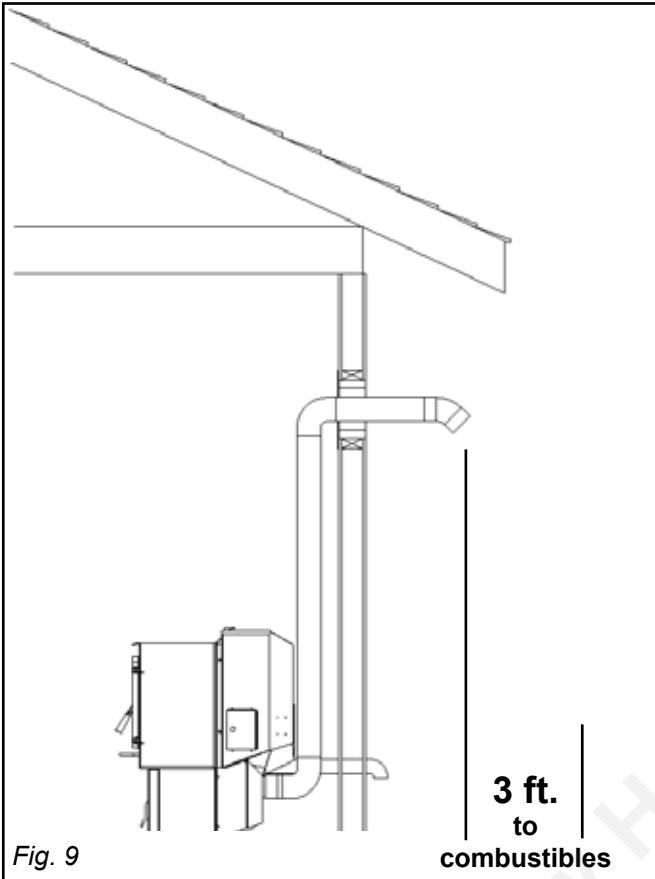

#1 Preferred method

This method provides excellent venting for normal operation and allows the stove to be installed closest to the wall. Two inches from the wall is safe; however, four inches allows better access to remove the rear panel. The vertical portion of the vent should be three to five feet high. This vertical section will help to provide natural draft in the event of a power failure.

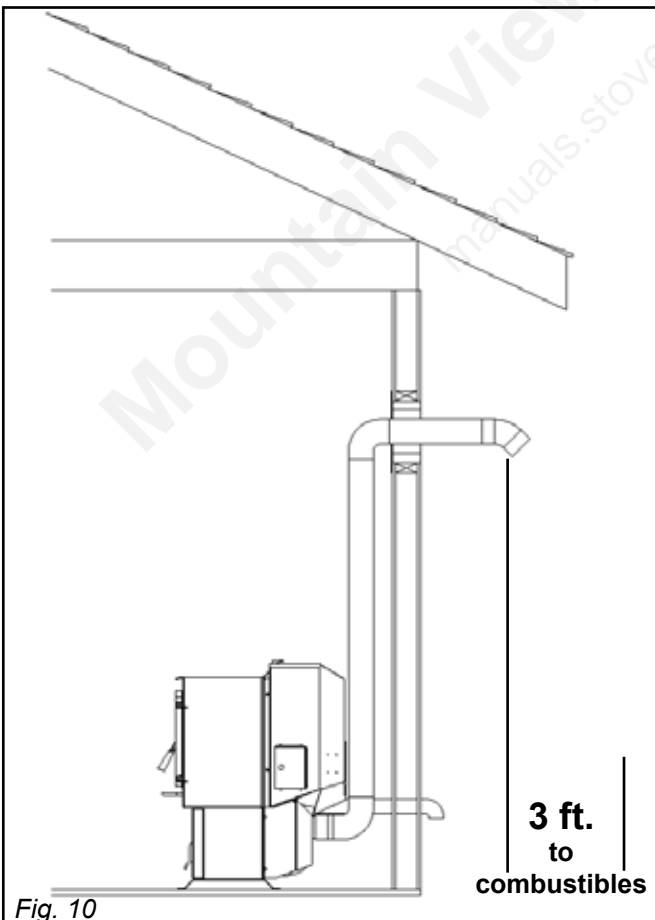

#2 Preferred method

This method also provides excellent venting for normal operation but requires the stove to be installed farther from the wall. The vertical portion of the vent should be three to five feet high and at least three inches from a combustible wall. This vertical section will help to provide natural draft in the event of a power failure. If the stove is installed below grade the vent termination should be at least 1 foot above grade.

CAUTION

Keep combustible materials (such as grass, leaves, etc.) at least 3 feet away from the flue outlet on the outside of the building.

Venting

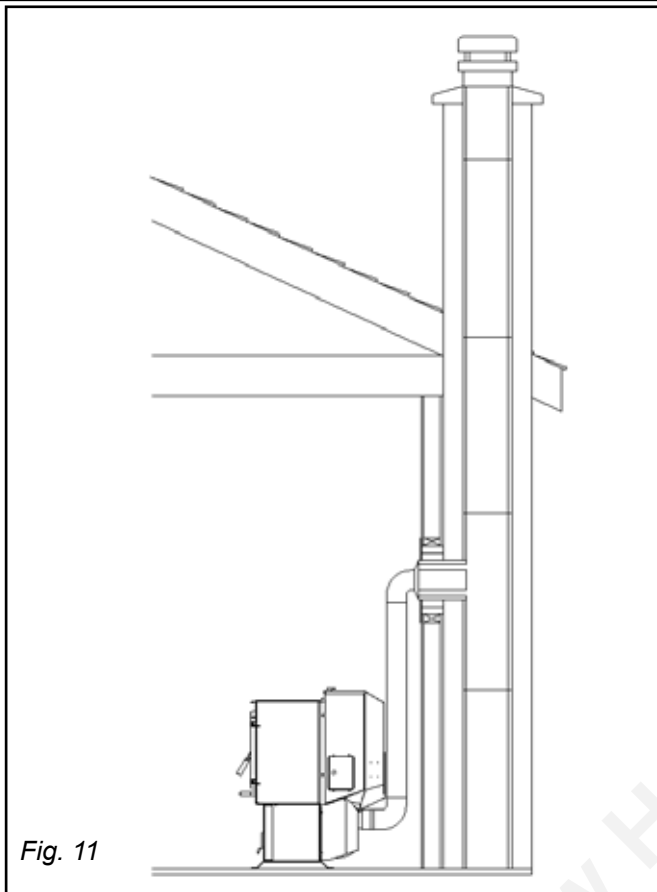

Fig. 11

#3 Installing into an existing chimney

This method provides excellent venting for normal operation. This method also provides natural draft in the event of a power failure. If the chimney condition is questionable you may want to install a liner as in method #6. Check with your local regulations, some municipalities require a complete liner.

Chimney must be of a type suitable for solid fuel burning.

Chimney and connector must be maintained in good condition and kept clean.

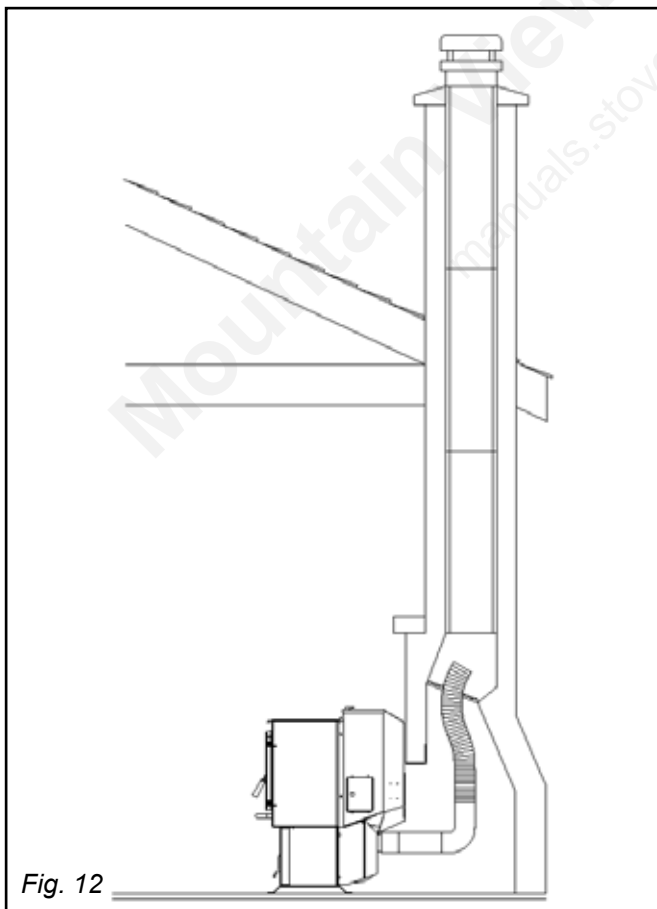

Fig. 12

#4 Installing into an existing fireplace chimney

This method provides excellent venting for normal operation. This method also provides natural draft in the event of a power failure.

The damper area must be sealed with a steel plate. Kaowool, mineral wool or an equivalent non-combustible insulation is recommended to be installed on top of the sealing plate to reduce the possibility of condensation. The connector pipe should extend through the smoke chamber to the base or into the first flue tile. A cap should be installed on the chimney to keep out rain. If the chimney condition is questionable you may want to install a liner all the way to the top as in method #5. Check with your local regulations, some municipalities require a complete liner.

Chimney must be of a type suitable for solid fuel burning.

Chimney and connector must be maintained in good condition and kept clean.

Venting

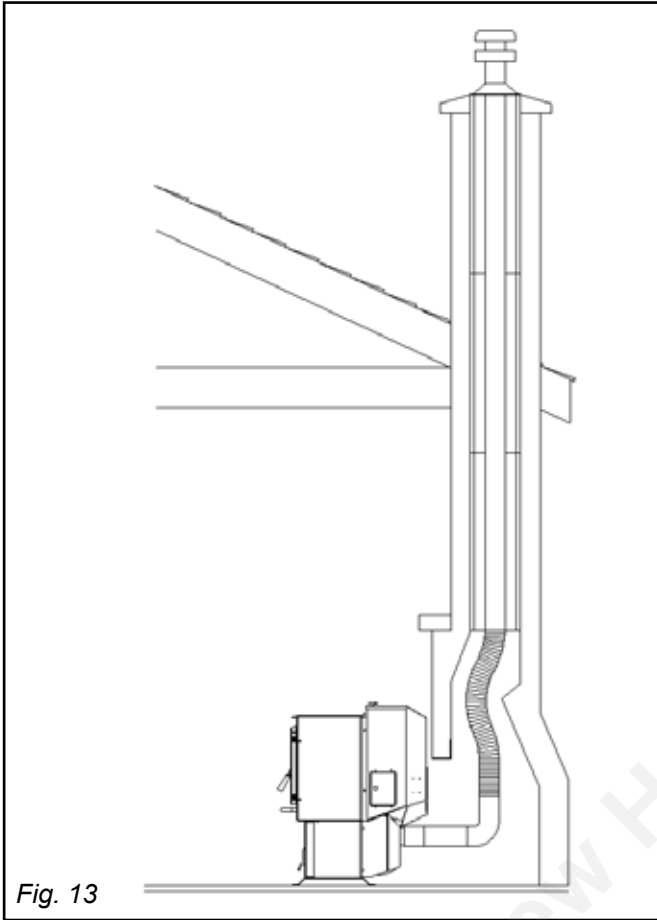

Fig. 13

#5 Installing into an existing fireplace chimney

This method provides excellent venting for normal operation. This method also provides natural draft in the event of a power failure.

In some places in the US and Canada, it is required that the vent pipe extend all the way to the top of the chimney. Check with your local codes.

In this method a cap should also be installed on the chimney to keep out rain. Be sure to use approved pellet vent pipe fittings. Seal pipe joints with silicone in addition to the sealing system used by the manufacturer. Pipe size should be increased to 4" using this method.

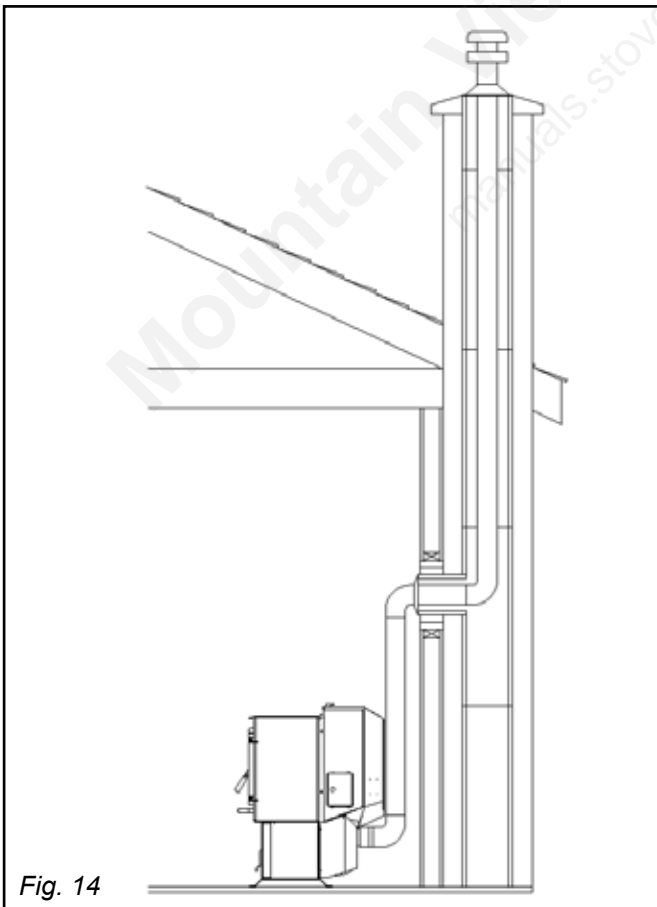

Fig. 14

6 Installing into an existing chimney

This method provides excellent venting for normal operation. This method also provides natural draft in the event of a power failure.

In some places in the US and Canada, it is required that the vent pipe extend all the way to the top of the chimney. Check with your local codes. The pipe or liner inside the chimney should be 4" diameter.

In this method a cap should also be installed on the chimney to keep out rain.

Venting

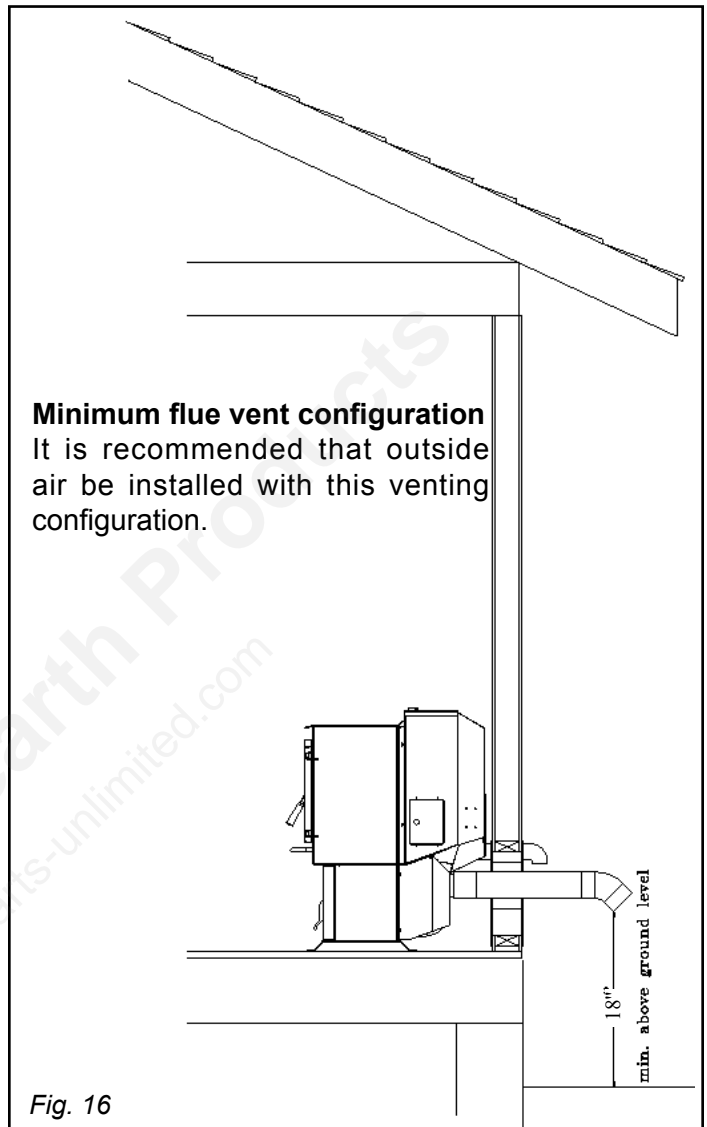
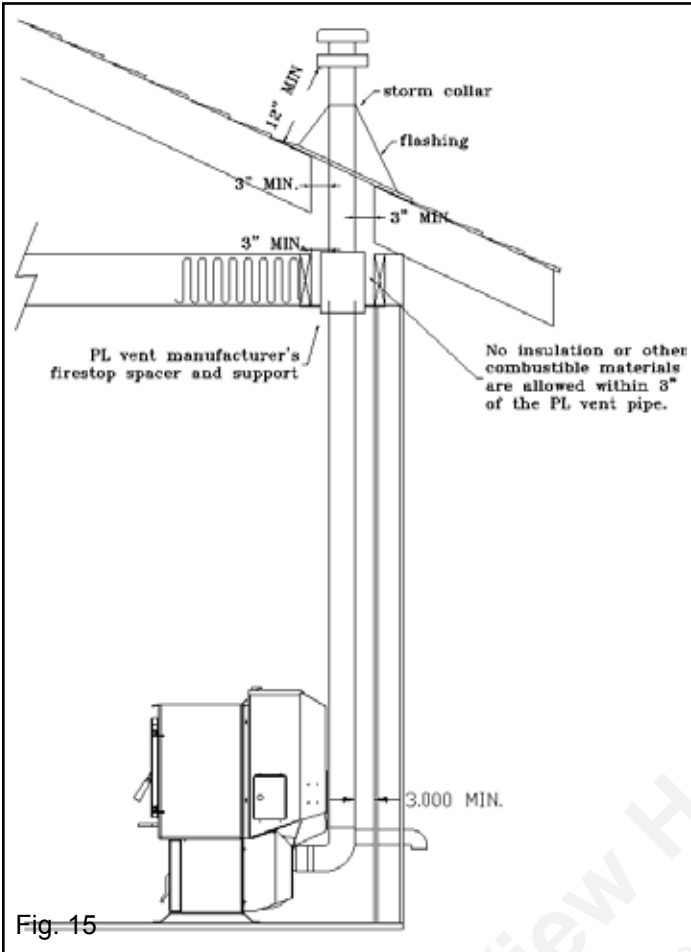

Minimum flue vent configuration
It is recommended that outside air be installed with this venting configuration.

#7 Installing through the ceiling vent

Through the ceiling vent, follow PL vent manufacturers recommendations when using wall and ceiling pass through.

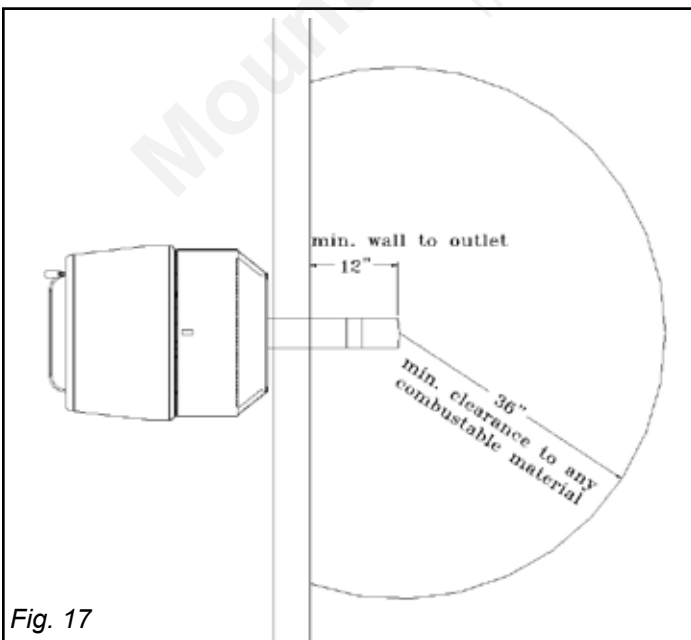

DO NOT INSTALL A FLUE DAMPER IN THE EXHAUST VENTING SYSTEM OF THIS UNIT.

DO NOT CONNECT THIS UNIT TO A CHIMNEY FLUE SERVING ANOTHER APPLIANCE.

INSTALL VENT AT CLEARANCES SPECIFIED BY THE MANUFACTURER

CAUTION

STOVE IS HOT WHILE IN OPERATION. KEEP CHILDREN, CLOTHING, AND FURNITURE AWAY. CONTACT MAY CAUSE SKIN BURNS.

Grain Cap Installation

The grain cap is designed to enhance the burn quality of the fuel being burned (i.e. field corn, wheat, barley, rye, oats, etc.) Its purpose is to reflect more heat into the burn pot. This promotes a more thorough burning of the fuel and less ash. Depending on the quality of the fuel being burned, the effectiveness of the grain cap may vary.

The grain cap will need to be removed for cleaning. This part is classified as a consumable item and is excluded from the product warranty.

Installation:

1. Hook the slot on the grain cap over the lip on the side rail of the burnpot, as shown.
2. Allow the grain cap to rest onto the burnpot sides.

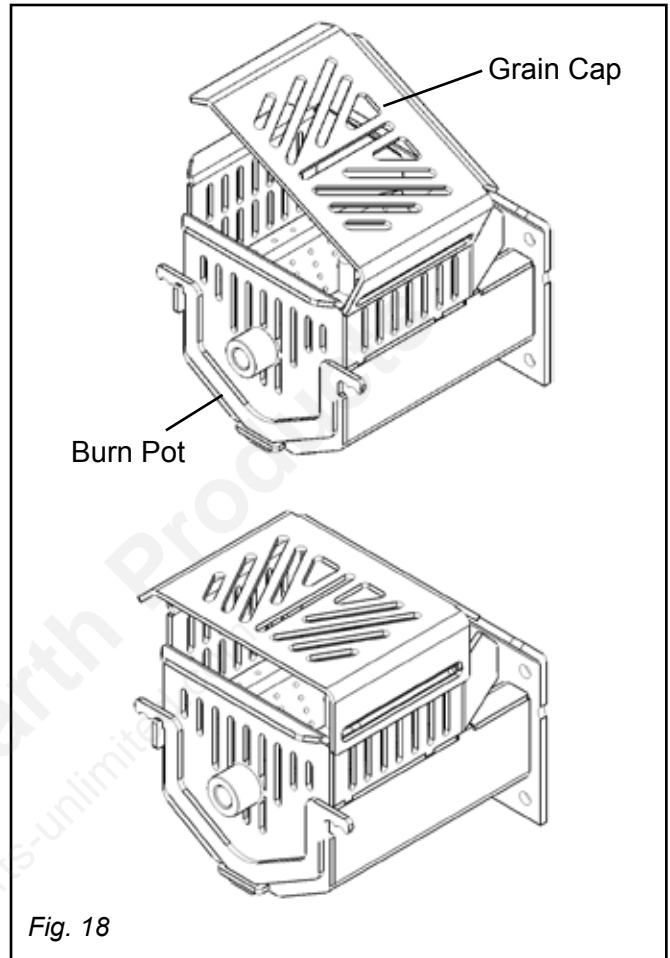

Burn Pot with Smaller Holes

The PC45 stove is built with a burn pot that has .125 (1/8") combustion air holes. This grate has no identifying marks.

Included with your stove is an additional grate that has .0625 (1/16") combustion air holes. This grate can be identified with etchings on the bottom side. An 'S' is etched on one end and '724208' is etched at the other end.

Depending on the type and the moisture content, some corn or grain will burn better with the smaller holes for combustion air, while others may work better with the larger holes.

To change the burn pot grate, first remove the end gate retainer, the nth the end gate. Pull the auger extension from the auger, and lift the grate out of the frame. Place the new grate, install the auger extension, replace the end gate and retainer clip. Refer to the diagrams on the next page for guidance.

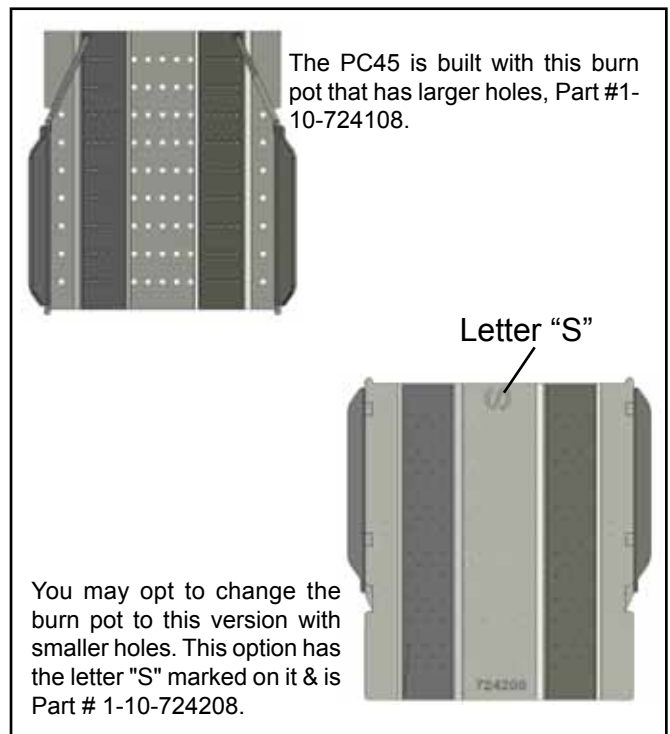

Pellet Fuel Optimization

For optimal performance burning wood pellets, the pellet kit #1-00-06801 is now included. This kit allows you to convert the PC45 into a fully automatic pellet stove with 50,000 BTU capacity, fast ignition and clean viewing glass. Since there may be changes needed for the circuit board programming, it is recommended that this installation be completed by a trained service technician. Be sure the power cord is un-plugged prior to adjusting circuit board switches. The pellet kit contains the instructions for the conversion, a new burn pot end gate, and a new combustion blower inlet ring.

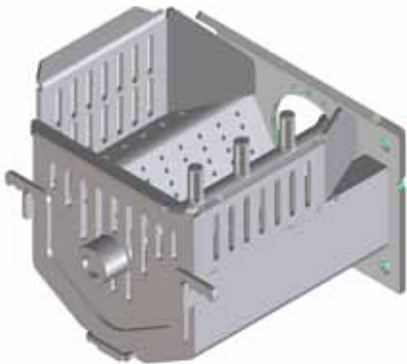
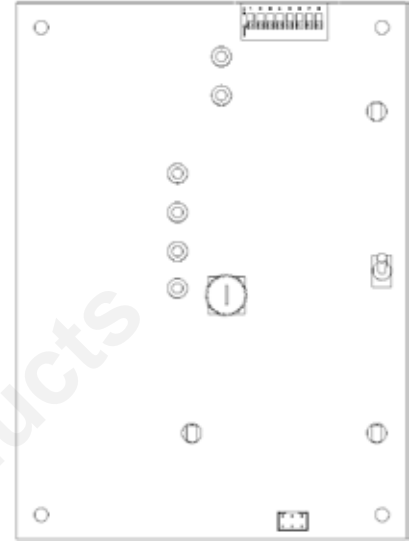

This figure shows the corn burn pot as installed from the factory.

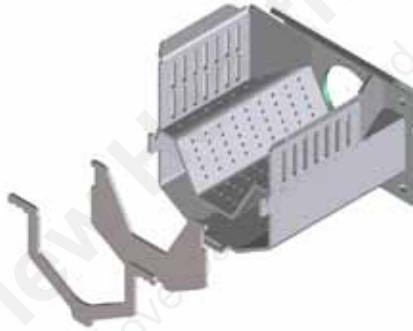

This figure shows the new end gate which gets installed without the stirring rod.

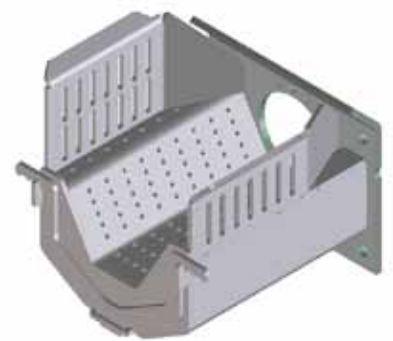

This figure shows the pellet burn pot after installing the new end gate.

The combustion blower inlet ring on the left is the one originally installed in the stove. Note the larger opening in the ring on the right. This allows the PC45 to produce more heat when burning pellets. The larger ring does the opposite when burning corn. If you want to switch back to corn or grain, exchange the inlet ring back to the smaller opening.

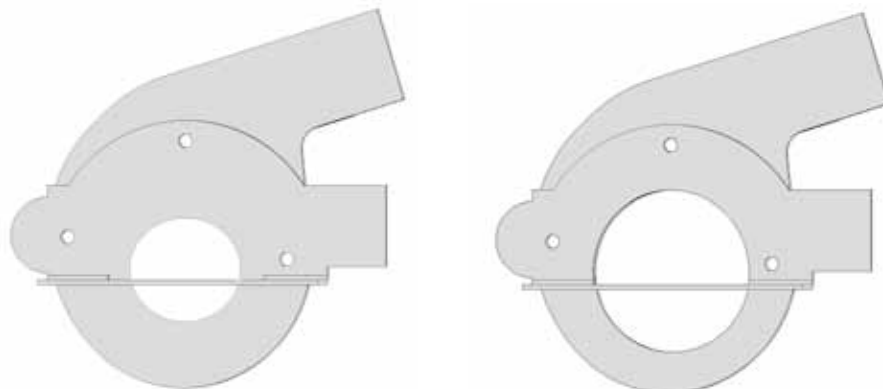

AUTOMATIC IGNITION/OPERATION

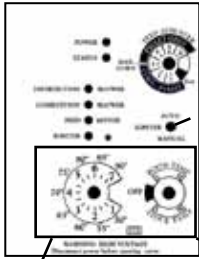

The PC45 corn/pellet stove is more than just automatic ignition, it is also automatic temperature control. The automatic system will allow the fire size to be adjusted to match the heating needs and even put the fire out if necessary. If heat is needed after the fire is out, the PC 45 will automatically re-ignite and adjust the fire size to match the heating need. The totally automatic room sensor mode is recommended because of its efficiency. The unit can be switched between "AUTO" and "MANUAL" at any time during operation.

Igniter Switch to "AUTO"

Room Temperature Mode

In "Room Temp Mode" heat output is controlled automatically by the Room Sensing Probe. When the Room Sensing Probe calls for heat, the stove will increase output. When the Room Sensing Probe is getting close to the set temperature, the stove will begin to level off output and keep the fire burning at just the right temperature to maintain that setting.

High output is determined by the feed rate setting. This setting, generally on #2 (corn) or #4 (pellet), can be increased if higher burn rates are necessary.

When burning corn the feed rate setting can be adjusted anywhere within the yellow range with a #3 setting being the maximum setting, #1 the lowest setting. This setting will vary depending on the quality of corn used.

When burning pellets the feed rate setting can be adjusted within the full range between #1 on the low side to #6 on the high side.

Overfeeding is not a safety concern, but the fire may be pushed off the burnpot and extinguish in the ash pan.

In "Room Temp Mode" a constant fuel consumption rate is sacrificed for exact room temperature. Therefore, as it gets colder more fuel will be burned automatically.

The distribution blower speed will vary according to the position of the mode selector pointer, and fire size.

Igniter Switch to "AUTO"

Stove Temperature Mode

This allows for automatic ignition upon start-up only. The unit can then be set at any desired setting. The heat output and fuel consumption will remain constant regardless of room temperature.

The unit's low burn or maintenance setting is as low as it will go. It will not go out unless it runs out of fuel or is turned off.

Shut-Down Procedure

To kill the fire or stop burning the stove, turn the Mode Selector to "OFF". This will cause the fire to diminish and burn out. When the fire burns out and the stove cools down everything will stop.

NOTE: The combustion blower motor will be the last component to stop. This insures that all fuel in the burnpot and ashes located in the ash pan are completely cold before shut down of the combustion motor.

If you pull the plug to shut down the stove, all motors will stop. This may cause incomplete combustion and smoke in the firebox. If the load door is opened the smoke may escape.

The best way to shut down the stove is to simply let it run out of fuel, then the stove will shut down automatically.

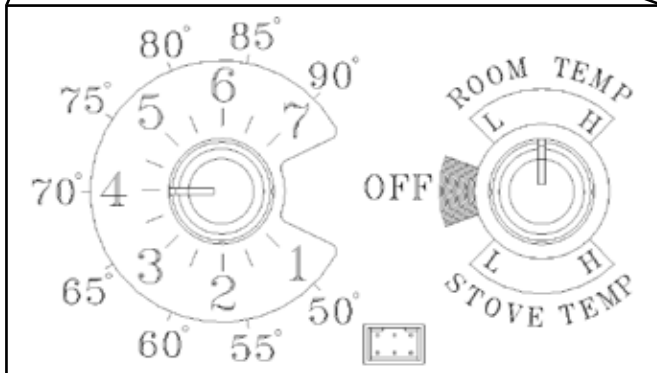
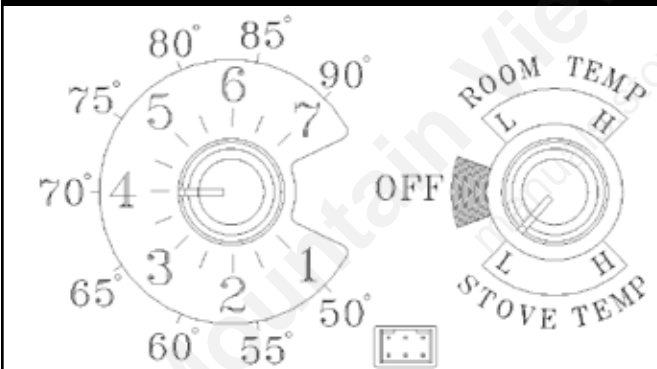

Fig. 19: **Room Temperature Mode:** This setting will produce a room temperature of 70 degrees with the distribution blower at medium speed.

Stove Temperature Mode



This setting will produce medium heat with the distribution blower on "low".

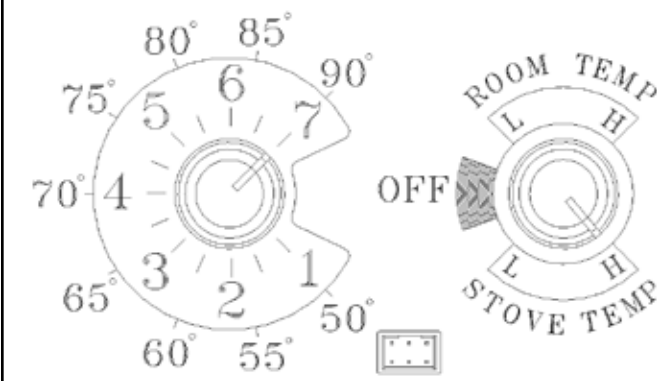

Fig. 20: This setting will produce continuous maximum heat output with the distribution blower at full speed.

AUTOMATIC START UP



Fig. 21

CAUTION:

DO **NOT** CONNECT TO ANY AIR DISTRIBUTION DUCT OR SYSTEM.

DO **NOT** BURN GARBAGE OR FLAMMABLE FLUIDS SUCH AS GASOLINE, NAPHTHA, OR ENGINE OIL.

HOT WHILE IN OPERATION. KEEP CHILDREN, CLOTHING, AND FURNITURE AWAY. CONTACT MAY CAUSE SKIN BURNS.

KEEP FIREBOX AND ASH REMOVAL DOORS CLOSED DURING OPERATION. MAINTAIN SEALS IN GOOD CONDITION.

Starting the Fire

Igniter Switch to "AUTO" (up position)

Make sure the unit is plugged into a 120 VAC, 60 HZ electrical source. The power light should be the only light lit. Anytime there is an interruption in power at the receptacle, the combustion blower will run for 1 minute after the power is restored. The control uses this time to determine exhaust temperature and if there is a need to remain on.

BE SURE THERE IS NO FUEL OR OTHER COMBUSTIBLES IN THE ASH PAN PRIOR TO LIGHTING.

1. Turn the Mode Selector to "OFF"
2. Fill the hopper with corn or pellets.
3. Clean the burn pot and housing, if necessary.
4. If starting after an empty hopper, turn the feed adjuster to "TEST" until the fuel is visible in the auger tube opening. This also allows you to check the motors for operation.
NOTE: The auger motor will not operate with the view door or ash door open.
NOTE: The initial start-up on a new stove may require the corn to be purged into the burnpot area before continuing to step 5.
5. Turn the feed adjuster to #2 (corn) or #4 (pellet)
6. Flip the igniter switch up into the "AUTO" position.
7. Turn the temperature dial to the desired setting.
8. Turn the mode selector dial to Room Temperature or Stove Temperature.
9. Fill the hopper with corn or pellets and remove the ashes as required.

Warning

"NEVER USE GASOLINE, GASOLINE-TYPE LANTERN FUEL, KEROSENE, CHARCOAL LIGHTER FLUID, OR SIMILAR LIQUIDS TO START OR "FRESHEN UP " A FIRE IN THIS HEATER. KEEP ALL SUCH LIQUIDS WELL AWAY FROM THE HEATER WHILE IN USE".

MANUAL IGNITION/OPERATION

The PC45 Corn/Pellet Stove is capable of manual operation. This also allows the operator to manually control operation during an emergency (i.e. igniter failure, when using some types of auxiliary power.)

The unit can be switched between "AUTO" and "MANUAL" at any time during operation.

NOTE: When starting the unit in the "AUTO" mode and switching to "MANUAL", wait until the igniter light (located on the control board) comes on to confirm the ignition cycle has begun.

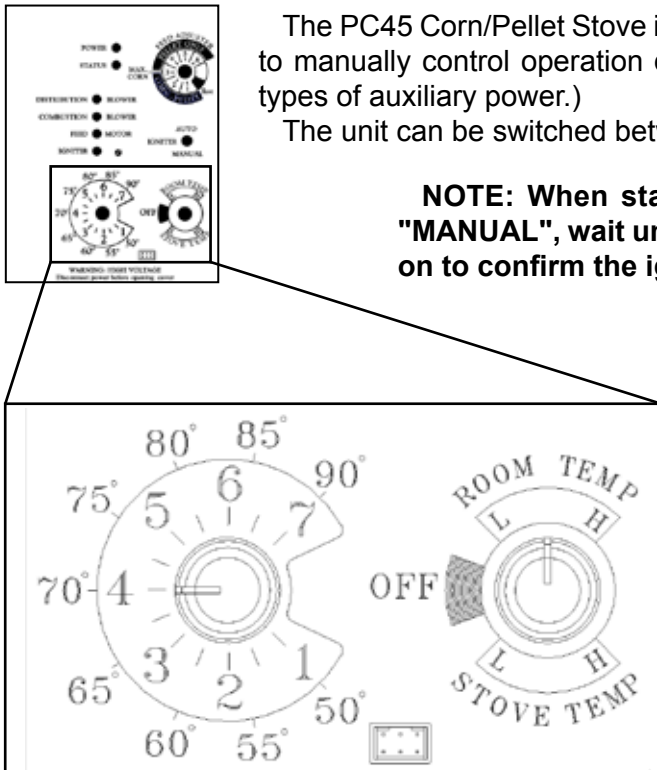

Fig. 22: Room Temperature Mode: This setting will produce a room temperature of 70 degrees with the distribution blower at medium speed.

Igniter Switch to "MANUAL"

Room Temperature Mode

The fire will have to be lit with starting gel and a match, or started automatically, see "Automatic Operation". Turn to "Manual" position when the ignition cycle has started.

The difference between "AUTO" Room Temperature Mode and "Manual" Room Temperature Mode is that the fire will not go out as the room temperature goes above the control board setting. The unit can only go to low burn and will remain there until it runs out of fuel or until more heat is needed and the feed rate increases. Feed rate adjustments and dial settings are the same as "AUTO" settings.

Manual Stove Temperature Mode

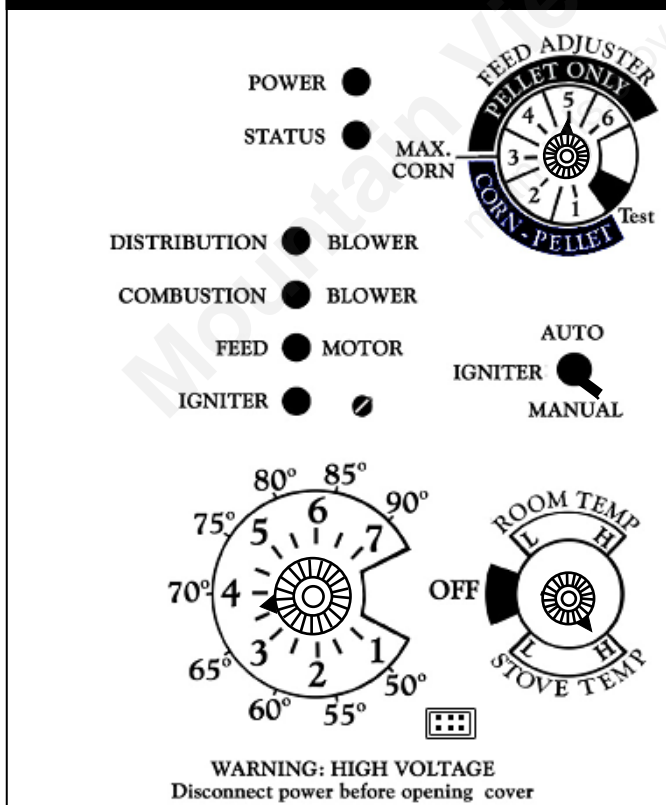

Fig. 23: This setting will produce a large viewing fire without a distribution blower operating.

Igniter Switch to "MANUAL"

Stove Temperature Mode

The advantage of this mode is to allow the operator to have a large viewing fire without blowing extra heat into the room.

During operation, with the temperature dial set at #4 or less, the distribution fan will not operate. Therefore, there can be a higher burn rate (a larger viewing fire) without an excess of hot air blowing into the room.

An example of when to use the Manual Stove Temperature Mode is if you want to watch a large fire and the room is already up to temperature. The Stove Temperature Mode allows you to have a larger fire and a lower sound level, without the distribution blower.

NOTE: During the use of this mode, if you keep increasing the temperature dial setting to increase the fire size, the distribution blower will automatically come on when the ESP Temperature reaches 350° F, or 81% output.

MANUAL START UP



Fig. 24

Corn Burnpot Setup

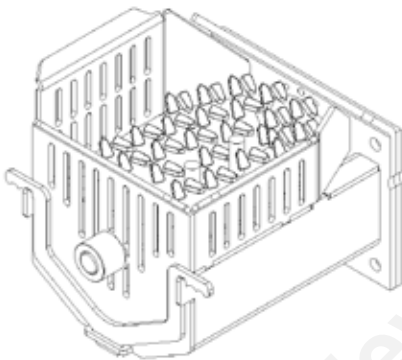

Fig. 25

Pellet Burnpot Setup

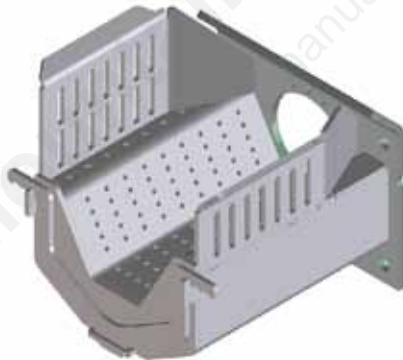

Fig. 26

Warning

"NEVER USE GASOLINE, GASOLINE-TYPE LANTERN FUEL, KEROSENE, CHARCOAL LIGHTER FLUID, OR SIMILAR LIQUIDS TO START OR "FRESHEN UP " A FIRE IN THIS HEATER. KEEP ALL SUCH LIQUIDS WELL AWAY FROM THE HEATER WHILE IN USE".

Starting the Fire

Igniter Switch to "MANUAL" (down Position)

Make sure the unit is plugged into a 120 VAC, 60 HZ electrical source. The power light should be the only light lit. Anytime there is interruption in power at the receptacle, the combustion blower will run for 1 minute after the power is regained.

Burning Corn

1. Turn the Feed Adjuster to the desired feed rate, approximately #2.
2. Turn the Mode Selector to "OFF" and then to the desired mode. This will reset the control and start the combustion motor.
3. Turn the Temperature Dial to the desired setting.
4. Clean the burnpot and housing, if necessary.
5. Fill the burnpot with corn up to the auger shaft. Then place pellets on top of the corn as high as the shelf area. See corn burnpot shown on left.
6. Add starting gel on top of the pellets, stir gel into the pellets and corn for faster lighting.
7. Light the starting gel with a match and close the door. Operation will begin when the fire reaches the proper temperature.
8. Fill the hopper with corn and remove the ashes as required.

Burning Pellets

1. Turn the Feed Adjuster to the desired feed rate, approximately #4.
2. Turn the Mode Selector to "OFF" and then to the desired mode. This will reset the control and start the combustion motor.
3. Turn the Temperature Dial to the desired setting.
4. Clean the burnpot and housing, if necessary.
5. Fill the burnpot with pellets so that the auger tube opening is covered and slopes away from the auger tube opening. See pellet burnpot shown on left. If using corn burnpot setup, fill to same level as corn above.
6. Add the starting gel on top of the pellets. Stir the gel into the pellets for fast lighting.
7. Light the starting gel with a match and close the door. Operation will begin when the fire reaches the proper temperature.
8. Fill the hopper with pellets and remove the ashes as required.

Shut-Down Procedure

To kill the fire or stop burning the stove, turn the Mode Selector to "OFF". This will cause the fire to diminish and burn out. When the fire burns out and the stove cools down everything will stop. **NOTE: The combustion blower motor will be the last component to stop.** This insures that all fuel in the burnpot and ashes located in the ash pan are completely cold before shut down of the combustion motor.

If you pull the plug to shut down the stove, all motors will stop. This may cause incomplete combustion and smoke in the firebox. If the load door is opened the smoke may escape.

The best way to shut down the stove is simply let it run out of fuel, then the stove will shut down automatically.

AUTOMATIC IGNITION ESP CONTROL

Power Light

Indicates power to the control.

Status Light

Will be lit in either stove or room temp mode when pointer is not within off position band except after normal shut down. Blinks to indicate errors listed below.

Indicates power to distribution blower.

Indicates power to combustion blower.

Indicates power to the feed motor.

Indicates igniter is on.

Temp dial

Allows you to adjust the room temperature in Room Temp Mode using the outer scale marked in degrees Fahrenheit. It also allows you to adjust the stove temperature while in Stove Temp Mode using the inner scale marked from 1 to 7.

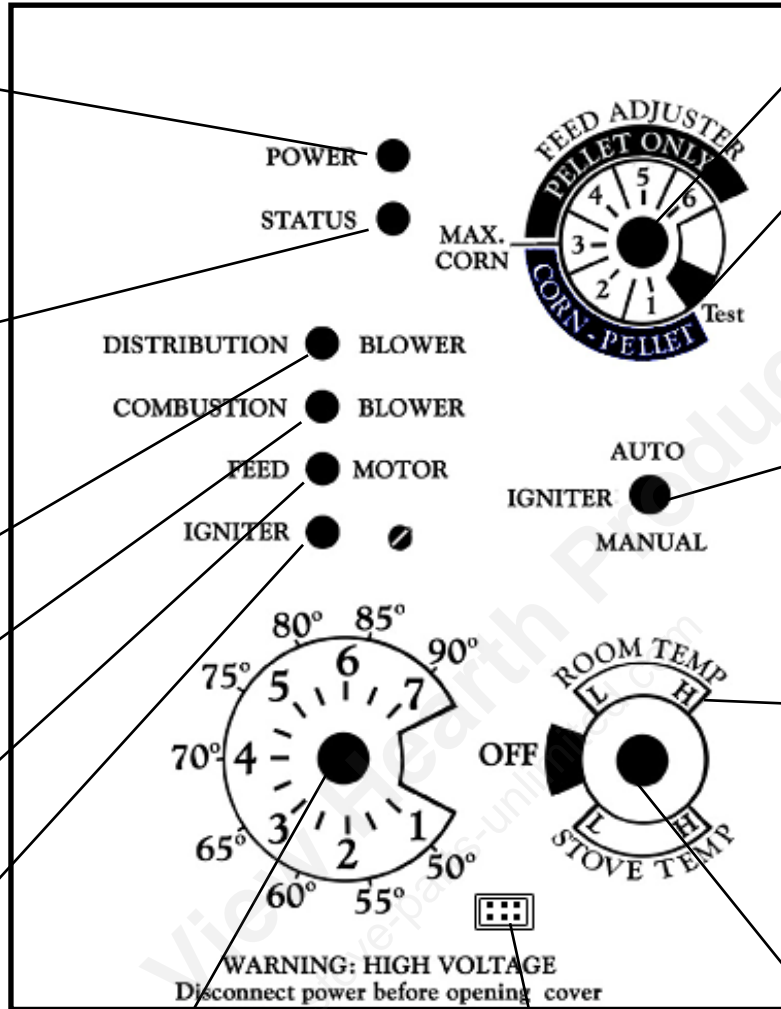

Feed adjuster

Sets the maximum feed rate.

Test

Runs all motors at full speed for one minute to check operation. Afterward the combustion blower will go to minimum and stay there.

Igniter switch

Set to appropriate Start-Up mode.

Distribution Blower speed adjustment range.

L = low

H = high

Variable speed anywhere between L and H; although as the stove temp. goes up, so does the L and H scale.

Mode Selector

Allows you to choose between Room Temp Mode, Stove Temp Mode, or OFF. Also allows you to vary the distribution blower speed by turning the knob to the high or low side of each mode.

Dealer Diagnostic Port

For dealer maintenance use only. Requires special DDM monitor supplied to Harman Dealers exclusively.

Status light error message

3 Blinks: Indicates that the ESP (Exhaust Sensing Probe) has gone out of range too many times in a specified time. Perform a manual reset*. If the code returns immediately, the ESP may be damaged or disconnected. Otherwise, the exhaust system may need cleaned..

4 Blinks: Can occur only in Room Temp Mode and indicates Room Sensing Probe failed or not installed. If a Room Sensing Probe is then installed, the status light will automatically reset.

NOTE: Unit will not start in "AUTO" with this status error.

5 Blinks (In Igniter Auto. Mode Only): Indicates that the unit has failed to light within the 45 minute start cycle. To reset - Turn Mode Selector to "OFF", then turn to either mode again.

6 Blinks : Indicates that the control has calculated poor or incomplete combustion occurring for more than 50 minutes. See Troubleshooting section for more details. A six blink status may be set if the stove is allowed to run out of pellets. To reset, turn mode selector to "OFF" then back on to the desired mode. If the unit was not out of pellets, see Troubleshooting section, Page 24, for more details.

* **Manual reset-** Disconnect the power cord for a few seconds and reconnect. If error still occurs call your Harman Dealer.

Low Draft Voltage Adjustment



Combustion Motor Speed Control

Low draft only set point.

The small straight screwdriver slot is plastic; therefore, the unit can be adjusted while in operation.

Fig. 27

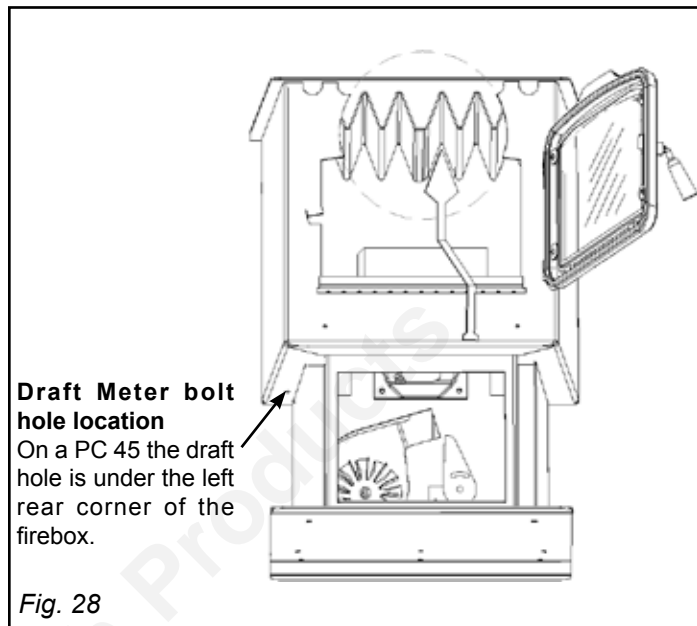

Draft Meter bolt hole location

On a PC 45 the draft hole is under the left rear corner of the firebox.

Fig. 28

Low Draft Voltage Adjustment

These units are pre-tested at the factory with exactly 120 Volts A.C., 60 Hz. They are checked and adjusted for firebox tightness, gasket leakage, motor operation and igniter operation. The PC 45 is then factory set at a mid-point adjustment and in most cases will not need any adjustments. **NOTE: The factory low draft setting may not be correct for the unit's permanent installation conditions.**

The control board on the PC45 is equipped with a low draft adjustment port. Located on the control face just to the right of the igniter light. This voltage adjustment is provided to allow the unit to be adjusted for the household voltage where the unit is going to be in permanent operation. **NOTE:** The line voltage varies from area to area and often home to home.

The low draft voltage should be adjusted to achieve the most efficient burn on low burn or "maintenance". This voltage adjustment allows the installer to change the low voltage set point approximately 10 volts. This adjustment should be done by the installer during set up because a draft meter reading is **required** to insure proper set up.

If the unit is not adjusted properly, it does not cause a safety concern. If the unit is adjusted too high, only efficiency is lost. If the unit is adjusted too low, the low draft pressure switch will not allow the feeder motor or the igniter to operate.

A simple draft test should be performed after completing the flue pipe installation. To record the results for future reference:

Draft Test Instructions

1. Attach a draft meter capable of reading up to a minimum of 0.5 inches of water column (W.C.).
2. Plug the unit's power cord into a 120VAC, 60 HZ grounded outlet.
3. Close the hopper lid, front view door, and the ash pan access door. Neither fuel or a fire are required for this test.
4. With the mode selector in the "OFF" position, turn the feed adjuster to "TEST".
5. Record the high draft _____ in W.C. (Normal is -.35 to -.55) The control will be on the High Draft for a minute.
6. After 1 minute is up, the combustion motor will go down to low draft and the distribution blower will go on high. Allow approximately 15 seconds to pass for the combustion motor to slow before checking the low draft.
7. If the low draft is between -.25 and -.35, record the reading ____ in W.C. If the reading is higher, slowly turn the set screw counter-clockwise until the draft lowers. If the reading is lower, very slowly turn the set screw clockwise until the draft increases.

NOTE: In some cases, the draft may not go as low as -.25 to -.35 even with the set screw completely counter-clockwise. This is not a problem. Vertical runs of venting may add natural draft.

If the draft reading does not drop at all when the test mode switches from high to low, be sure to check for restrictions in the appliance air intake.

Maintenance

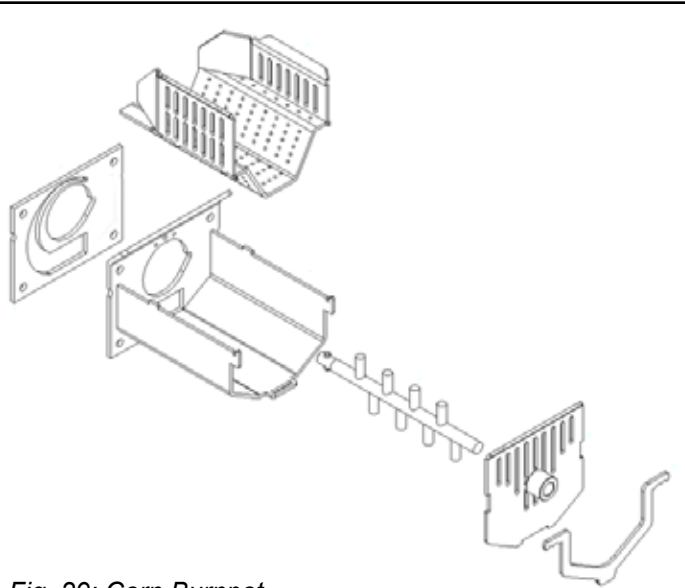

Fig. 29: Corn Burnpot

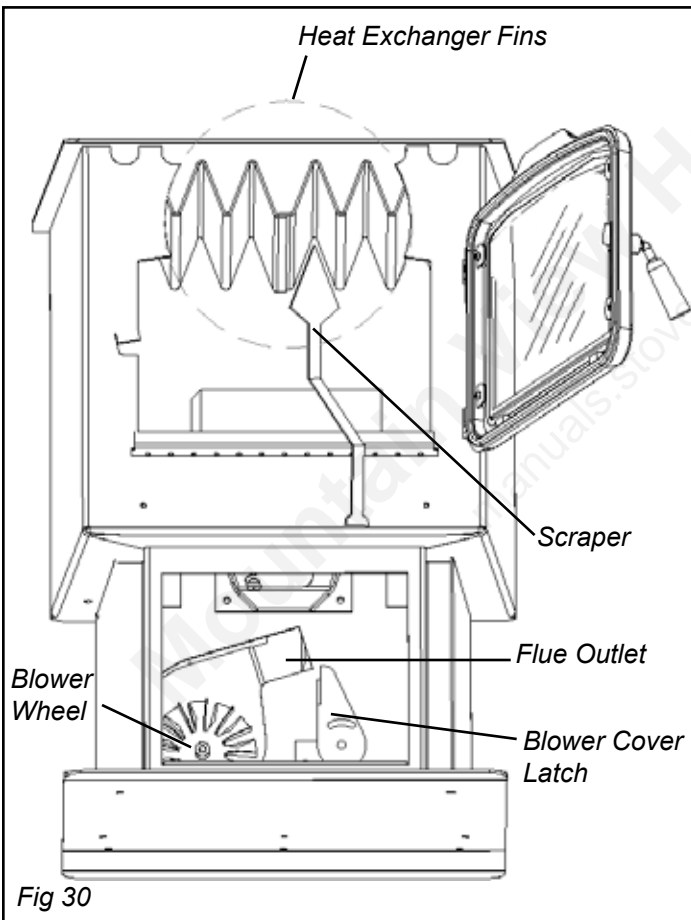

Fig 30

CREOSOTE

The chimney or venting system must be inspected regularly during the heating season to determine if a creosote build-up has occurred. If a significant layer of creosote has accumulated (3mm or more), it should be removed to reduce the risk of a chimney fire.

Removing Ashes:

The frequency of which you will need to empty the ash pan will vary depending on the conditions that the stove has been operating in. For example: A stove burning corn on high continuously will probably need the ashes removed every 1 to 2 days, whereas a stove burning corn on low or cycling off periodically may be able to go 3 to 8 days or longer. With pellets, after about 1 ton. It is recommended that the stove is cold and shut down when removing the ash pan.

1. Pull up on the latch handle to swing the ash pan access door out and to the right.
2. Use the ash pan handle to carry and dispose of ashes.
3. Slide the ash pan back into the stove.
4. Close and latch the ash pan access door.

Ashes should be placed in a metal container with a tight fitting lid. The closed container of ashes should be placed on a noncombustible floor or on the ground, well away from all combustible materials, pending final disposal. If ashes are disposed of by burial in soil or otherwise locally dispersed, they should be retained in the closed container until all cinders have thoroughly cooled.

Cleaning:

If you have been burning corn, the stove will need to be cleaned approximately once a month. The amount of corn burned and the frequency of these cleanings will vary depending on the quality of the corn used.

If you have been burning pellets, the stove will need to be cleaned approximately every 2 to 3 months. The amount of pellets burned and the frequency of these cleanings will vary depending on the quality of the pellets used.

1. Shut down the stove and **disconnect the power cord** to insure that all motors are stopped.
2. Clean the heat exchanger with the scraper as shown in Fig. 30.
3. Brush or scrape the inside walls of the stove to remove fly ash.
4. Remove the burn pot for cleaning by:
 - Lift up and remove the front plate lock & front plate.
 - Remove the auger extension (if installed).
 - Remove the burnpot grate.
 - Clean all fines and debris.
 - Reinstall in reverse order.

NOTE: See burnpot maintenance section for a more detailed description on burnpot maintenance and cleaning.

Maintenance

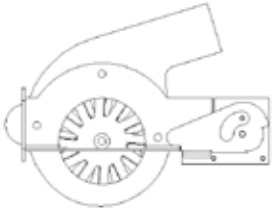

Fig. 31: Latch "closed" with blower cover in place.

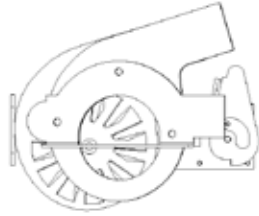

Fig. 32

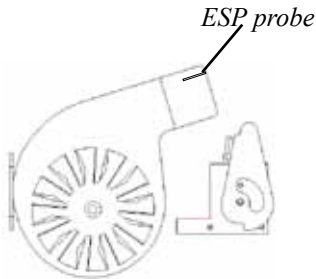

Fig. 33: Exposed blower wheel and flue opening, NOTE: ESP probe is visible.



Fig. 34: Blower cover removed.

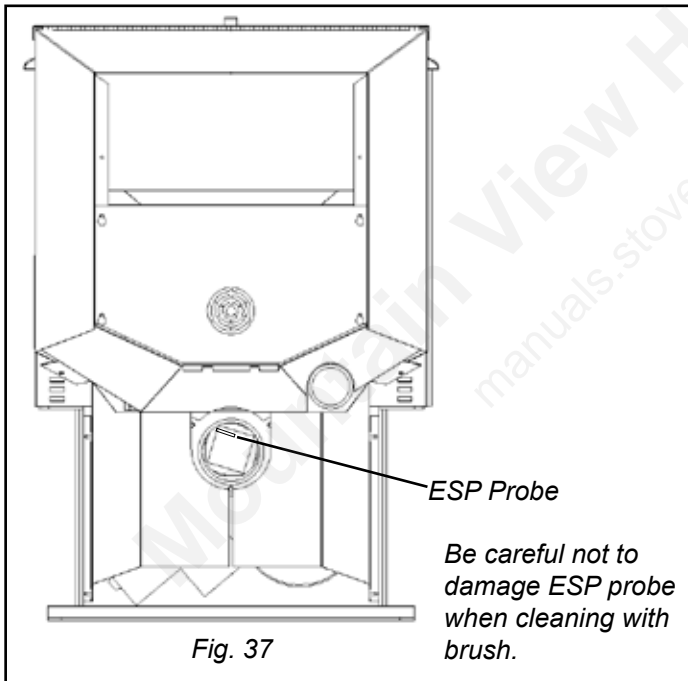

Fig. 37

(Cleaning continued)

5. Remove the ash pan.
6. Remove the combustion blower cover by turning the blower cover latch vertical as shown in fig. 32. Slide the cover out of the slot on the left. This will expose the combustion blower wheel and flue outlet, fig. 33.
7. Clean the blower wheel with a brush and a vacuum cleaner.

8. Use a brush to clean the flue, being careful not to damage the ESP probe. The flue goes straight through into the vent pipe therefore, the vent pipe can also be cleaned to some extent through the flue outlet.
9. Reinstall the blower cover and relatch.
10. Slide the ash pan into the stove and close and latch the door.

NOTE: ASHES MAY BE FINER THAN YOUR VACUUM FILTER. USE CAUTION WHEN VACUUMING AND KEEP FILTER CLEAN.

Cleaning of Feeder Fines Area

1. Remove the rear shields to access the feeder cover.
2. Remove the wing nut on the feeder cover and slide the cover off the threaded rod.
3. Remove all fines with a vacuum.
4. Replace the feeder cover and rear shields.

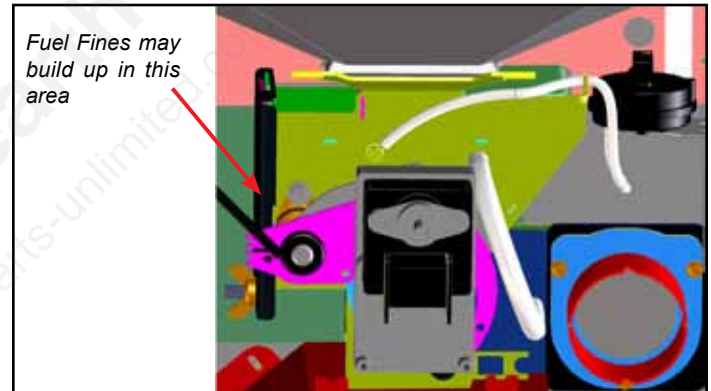

Fig. 36: For further details see exploded view on page 22.

Soot and Fly Ash

Formation and Need For Removal- The products of combustion will contain small particles of fly ash. The fly ash will collect in the exhaust venting system and restrict the flow of the flue gases. Incomplete combustion, such as occurs during startup, shutdown, or incorrect operation of the room heater, will lead to some soot formation which will collect in the exhaust venting system. The exhaust venting system should be inspected after the first month of burning to determine the frequency of cleaning that will be required, and at least yearly thereafter. NOTE: The frequency could vary from once a month to once a season depending on the quality of the fuel being used.

If You Experience A Chimney Fire; Do NOT disconnect power to the appliance. Do NOT put water on the fire.

Turn the selector dial to the OFF position and allow the unit to shut down on its' own. Have the appliance and venting system professionally inspected and cleaned prior to using.

Maintenance - Burn Pot

Burn Pot Cleaning and Maintenance

1. Be sure the stove power is turned off.
 2. Lift up and remove the front plate lock and front plate. Set aside the front plate.
 3. Remove the auger extension by pulling toward you, then set aside (corn burnpot only)
 4. Remove burnpot grate and set aside.
 5. Clean all fines and debris that has accumulated.
 6. Install the "cleaned" burnpot grate making sure the 2 holes line up with the 2 tabs in the burnpot housing.
 7. Now install the spare "clean" auger extension into the auger shaft. Make sure there isn't any corn or debris in the shaft opening. This will prevent the auger extension from being fully inserted into the shaft.
 8. Align the auger extension through the hole in the "clean" front plate and place front plate against the burnpot grate and housing.
 9. Install the front plate lock.
- NOTE: After cleaning of these parts, inspect for excessive wear and replace as needed.

Cleaning of Burnpot Parts

Cleaning can be performed in 2 basic ways:

1. Because the corn slag buildup will absorb moisture from the air when cool, the parts can just be left exposed for several days and the slag buildup will crumble off of the parts.
 2. To accelerate this process, the parts can be soaked in water for approximately 30 minutes (depending on the amount of buildup, they could be cleaned in less time).
- NOTE: Cleaning of these parts is not necessary until you see that there is a noticeable decrease in the quality of the flame in the burnpot. Example: Unburned fuel being pushed over the burnpot.

Safety Features

The low draft sensor which is a vacuum differential switch, monitors the negative pressure (draft) in the firebox through a port on the rear of the feeder. Poor draft can be caused by blockage in the exhaust, excessive build-up on the combustion blower fan blades, a failed combustion blower, or a door or other opening to the firebox not sealed properly.

The hopper lid position switch, located in the right rear corner of the hopper opening, senses the positioning of the hopper lid. The circuit board is monitoring the position of these switches. If either of these switches were to open, power to the igniter and the feed motor are interrupted. The indicator lights for these components may be illuminated even though power is not flowing to the components. Be sure all doors, including the hopper lid, are securely closed when operating the appliance.

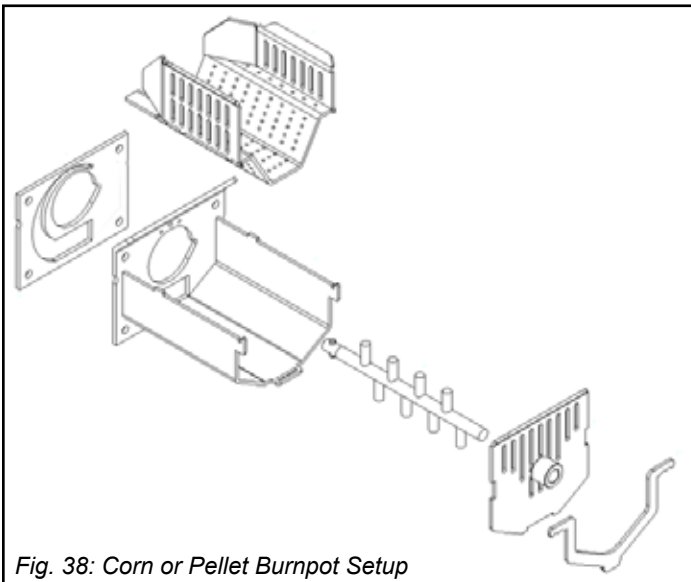

Fig. 38: Corn or Pellet Burnpot Setup

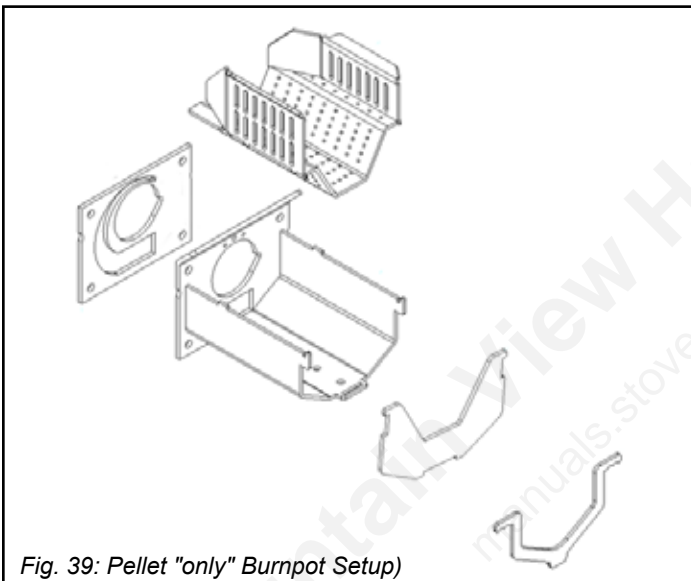

Fig. 39: Pellet "only" Burnpot Setup



**Hopper Lid
Position Switch**

Maintenance

Glass Care and Replacement

The glass in your Harman stove is a special ceramic glass.

- Do not abuse the glass by striking or slamming the door.
- Never burn the appliance if the door glass is cracked or broken.
- Replace only with Harman supplied glass.

Soot and/or fly-ash may accumulate on the viewing glass, and will occasionally need to be cleaned. Clean the glass with a soft cloth and mild glass cleaner. Do not clean the glass when hot, and avoid the use of abrasive cleaners.

Glass replacement

Carefully remove all remaining glass and gasket materials prior to replacing the glass.

Lay the door face down on a flat surface. Remove the glass retainers and screws. Apply the gasket material to the face of the new glass. Lay the glass into the door, making sure that the glass is contained within the channels and raised areas of the door itself. Lay the glass retainers into position and install the screws. Tighten each screw evenly to avoid making any stress points.

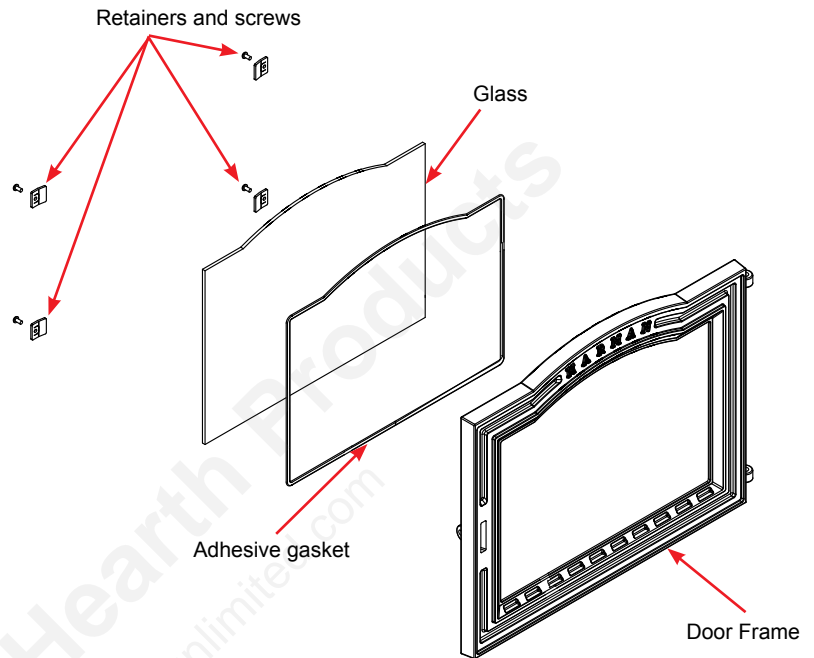

WARNING



INSPECT APPLIANCE AND COMPONENTS FOR DAMAGE. DAMAGED PARTS MAY IMPAIR SAFE OPERATION.

- DO NOT INSTALL DAMAGED COMPONENTS.
- DO NOT INSTALL INCOMPLETE COMPONENTS.
- DO NOT INSTALL SUBSTITUTE COMPONENTS.

REPORT DAMAGED PARTS TO DEALER.



WARNING



FIRE RISK.

HEARTH & HOME TECHNOLOGIES DISCLAIMS ANY RESPONSIBILITY FOR, AND THE WARRANTY WILL BE VOIDED BY, THE FOLLOWING ACTIONS:

- INSTALLATION AND USE OF ANY DAMAGED APPLIANCE.
- MODIFICATION OF THE APPLIANCE.
- INSTALLATION OTHER THAN AS INSTRUCTED BY HEARTH & HOME TECHNOLOGIES.
- INSTALLATION OF PARTS OR COMPONENTS NOT SUPPLIED OR APPROVED BY HEARTH & HOME TECHNOLOGIES.
- OPERATING APPLIANCE WITHOUT FULLY ASSEMBLING ALL COMPONENTS.

OR ANY SUCH ACTION THAT MAY CAUSE A FIRE HAZARD.

PC 45 Trouble-Shooting

FEEDER DOES NOT FEED

1. No fuel in hopper.
2. Firebox draft may be too low for low draft pressure switch in feeder circuit to operate. **Check for closed doors**, loose or missing gasket on doors or hopper lid, faulty pressure switch.
3. Feed motor will not run until ESP senses 200° F. Maybe you did not put enough fuel in the burn pot before lighting the fire.
4. Something is restricting flow in the hopper or causing the slide plate to stick.
5. Feed motor has failed.

PARTIALLY BURNED FUEL

1. Feed rate too high.
2. Draft too low.
3. Burn pot may need to be cleaned.
4. Combination of all the above.
5. #6 status blink: A 6 blink control board status indication is caused by poor or incomplete combustion. The circuit board has the ability to track the combustion through feed settings and ESP temperatures. When the control board has calculated poor or incomplete combustion it will shut down the unit as a safety feature. (Poor or incomplete combustion is a contributor of creasote which may cause a chimney fire)

A 6 blink status may be caused by several things:

1. Blocked or partially blocked flue.
2. Blocked or partially blocked inlet air.
 - a. backdraft damper on the inlet pipe may be stuck closed.
 - b. if outside air is installed the inlet cover may be blocked.
3. The air chamber under the burnpot may be filled with fines and small bits of ash.
4. The holes in the burnpot may be getting filled with ash or carbon buildup.
5. Combustion blower fan blades may need cleaned.
6. There is no fuel in the hopper.

COMBUSTION BLOWER RUNS AFTER SHUT DOWN

This is a normal function. The combustion blower will run for 5 hours after the stove is completely cool.

SMOKE SMELL

Seal the vent pipe joints and connection to stove with silicone.

FIRE HAS GONE OUT

1. No fuel in hopper.
2. Draft setting is too low.
3. Something is restricting fuel flow.
4. Feed motor or draft motor has failed.
5. Power failure or blown fuse.

SMOKE IS VISIBLE COMING OUT OF VENT

1. Air-fuel ratio is too rich.
 - A. Feed rate too high.
 - B. Draft too low caused by a gasket leak.
2. Unit is in an ignition cycle.

LOW HEAT OUTPUT

1. Feed rate too low
2. Temperature setting too low (Stove Temp Mode)
3. Draft too low because of gasket leak.
4. Poor quality or high moisture fuel.

Helpful Hints

Cleaning Burn Pot

Whenever your stove is not burning, take the opportunity to scrape the burn pot to remove carbon buildup. A vacuum cleaner is handy to remove the residue. Be sure the stove is cold if you use a vacuum.

Carbon buildup can be scraped loose with the fire burning using the special tool provided with your stove. Scrape the sides of the burnpot (corn grate), and the floor and sides (pellet grate). The carbon will be pushed out by the incoming fuel. Always wear gloves to do this.

Removing Ashes

Turn the Temp Dial to number 1 approximately 30 minutes before removing ashes. This will result in a cooler stove and ash pan.

Maximum Feed Adjuster settings are not needed in most cases. Operating in the normal range (#2 corn) (#4 pellet) is recommended when maximum heat output is not required. The ESP probe prevents the stove from being over-fired.

Keep the stove free of dust and dirt.

Fuel

The PC 45 can burn corn with moisture levels up to 16%, with 14.5% or less being ideal.

Pellet fuels are put into 3 categories in terms of ash content. Premium at 1% or less, Standard at 3% or less and all others at 3% or more.

The PC 45 is capable of burning all 3 categories of pellets due to a patented feeder and burn pot system.

It should be noted, however, that higher ash content will require more frequent ash removal and may provide less BTU's per pound. Normally, standard and high ash pellets cost less than premium pellets and can be cost effective when burned in the PC 45.

The moisture content of pellets must not exceed 8%. Higher moisture will rob BTU's and may not burn properly.

The PC45 is capable of burning grains other than corn, such as wheat, oats or barley. Grains vary widely from area to area, as will stove performance. When burning grains other than corn, it may be necessary to make changes to the settings on the circuit board for optimum performance. Contact your Harman Dealer for instructions.

Fuel Specification Details

Fuel and Fuel Storage

Pellet fuel quality can fluctuate from manufacturer to manufacturer, and even from bag to bag.

Hearth & Home Technologies recommends using only fuel that is certified by the Pellet Fuels Institute (PFI).

Fuel Material

- Made from sawdust and/or other wood by-products
- Shelled field corn
- Source material typically determines ash content

Higher Ash Content Material

- Hardwoods with high mineral content
- Bark and leaves as source material
- "Standard" grade pellets, corn and other biomass

Lower Ash Content Material

- Softwood; pine, fir, etc.
- Materials with lower mineral content
- "Premium" grade pellets

Shelled field corn other grains

- Must be 15% moisture content or less
- Must be clean and free of debris
- Stalk parts, excessive fines and cob remnants may cause feed system jams or blockage

CAUTION! Do not burn fuel that contains an additive; (such as soybean oil)

- May cause hopper fire
- Damage to product may result

Read the list of ingredients on the packaging. If you are buying field corn, the only ingredient listed should be field corn.

WARNING! Risk of Chemical Poisoning!

Do **NOT** burn treated seed corn

- Chemical pesticides are harmful or fatal if swallowed
- Burning treated seed corn will void the product warranty

Clinkers

Minerals and other non-combustible materials, like sand, will turn into a hard glass-like substance when heated.

Trees from different areas will vary in mineral content. For this reason, some fuels will produce more clinkers than others.

Moisture

Always burn dry fuel. Burning fuel with high moisture content takes energy to dry and tends to cool the appliance thus, robbing heat from your home. Damp pellet fuel could turn back into sawdust which does not flow properly through the feed system.

Size

- Pellets are either 1/4 inch or 5/16 inch (6-8mm) in diameter
- Length should be no more than 1-1/2 inches (38mm)
- Pellet length can vary from lot to lot from the same manufacturer

Performance

- Higher ash content requires more frequent maintenance.
- "Premium" grade pellets will produce the highest heat output.
- Burning pellets longer than 1-1/2 inches (38mm) can cause inconsistent feeding and/or ignition.

We recommend that you buy fuel in multi-ton lots whenever possible. However, we do recommend trying different brands prior to purchasing multi-ton lots, to ensure your satisfaction.

CAUTION! Tested and approved for use with wood pellets, shelled field corn, and grains such as wheat, barley, and oats ONLY. Burning of any other fuel will void your warranty.

When changing between fuels, the FEED ADJUSTER will likely need adjusted. When under maximum demand, ensure there is no unburned fuel being pushed into the ash pan.

Storage

- Wood pellets should be left in their original sealed bag until ready to use, to prevent moisture.
- Shelled corn and grains should be stored in a tightly sealed container to prevent moisture and to deter pests
- Do not store fuel within the specified clearance areas, or in a location that will interfere with routine cleaning and maintenance procedures.

CAUTION

Tested and approved for use with wood pellets and biomass fuels ONLY. Burning of any other fuel will void your warranty.

NOTICE

Hearth & Home Technologies is not responsible for stove performance or extra maintenance required as a result of using fuel with higher ash or mineral content.

Specifications

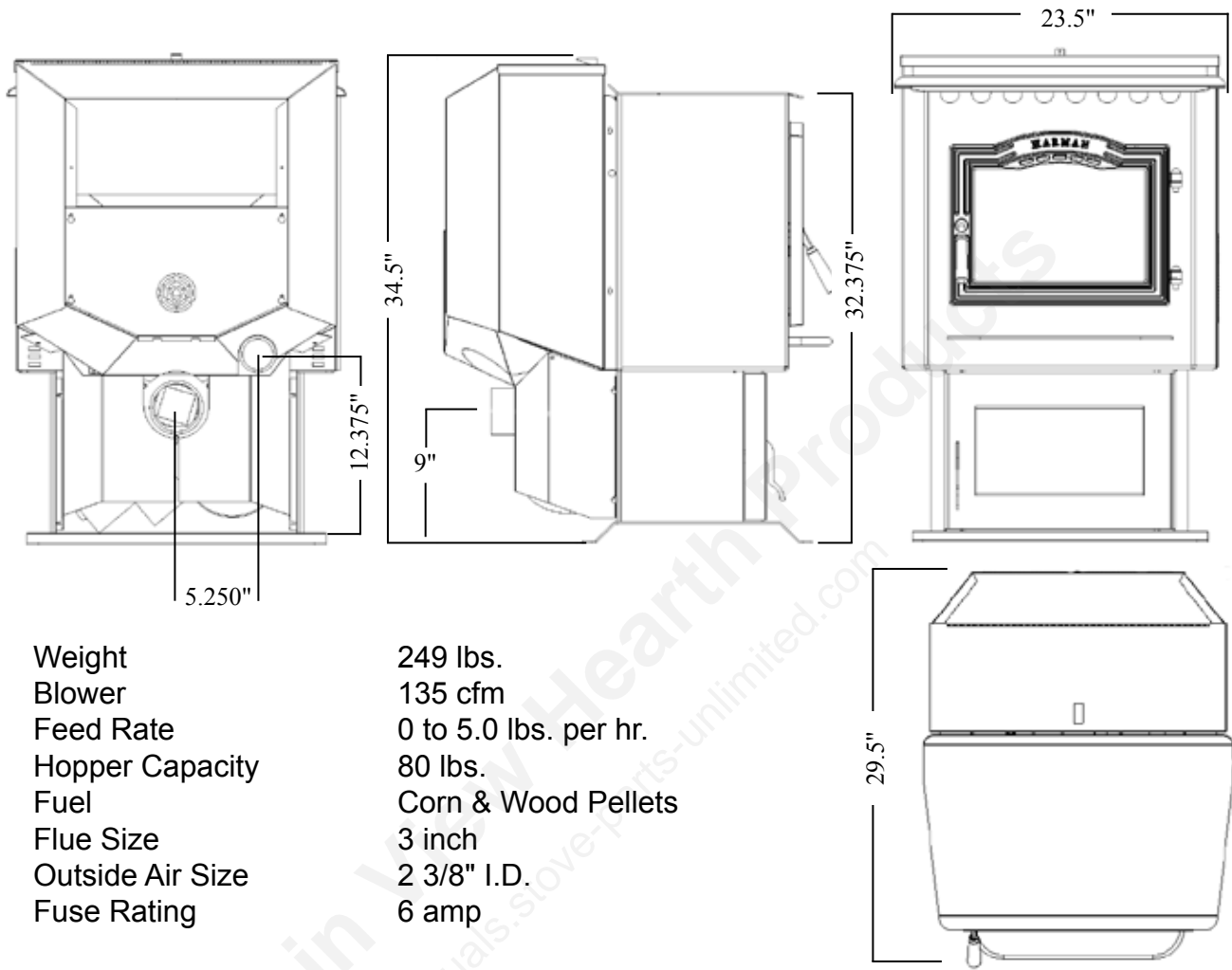

Weight	249 lbs.
Blower	135 cfm
Feed Rate	0 to 5.0 lbs. per hr.
Hopper Capacity	80 lbs.
Fuel	Corn & Wood Pellets
Flue Size	3 inch
Outside Air Size	2 3/8" I.D.
Fuse Rating	6 amp

Options

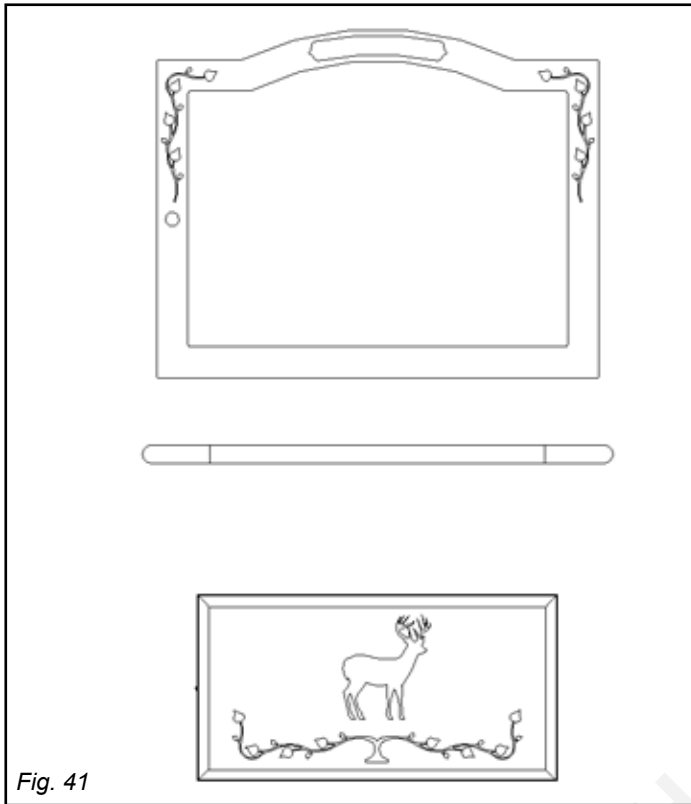

Fig. 41

Optional Trim

There are three different finishes to choose from, gold, brushed stainless, and bright nickel. Each trim kit includes a door frame, a drill bit for the load door holes, an ash door tile trim, and an ash fender trim. The ash door tile frame can be installed with or without the decorative tile.

To install the door frame, lay the frame face down on a soft surface. Fasten door frame by inserting the 4 threaded posts on the frame through the door. The posts should line up with the 4 holes located at the corners of the door. Once the posts are through the door, fasten frame with 4 nuts and tighten until the frame is snug.

To install ash lip trim, simply slide the trim over the ash lip and into the groove on the trim.

The ash door frame includes a bent spring clip. Insert the spring clip into one end of the frame. Start the frame into the recessed area of the ash door with the clip end first. push tension on the spring clip while inserting the other end of the frame into the recess.

Decorative Tile

Decorative tile is available in four choices of slate or a brushed stainless deer cutout (shown above). The tile installs behind the trim on the ash door.

Cleaning Plated Trim

Gold or nickel plated hardware should never be buffed or polished. Abrasive cleansers and metal polishes will remove the plating and therefore should never be used. If the plating needs to be cleaned, wait until the stove is completely cool, then use a sponge, soap and water to gently remove dirt and stains. Before relighting the stove, remove all soap residue and wipe dry.

Direct Vent Wall Passthrough

The direct vent wall passthrough allows you to bring outside air in for combustion, and safely pass your pellet venting through the wall while only needing to make one hole. The pass through is adjustable for different wall thickness from 4½" to 10⅞" thick. Item # 1-00-677077 is compatible with 3" venting only.

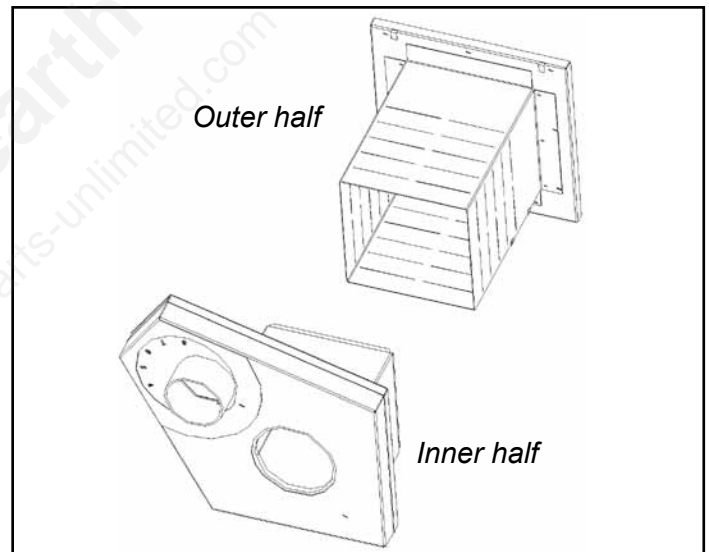

Optional Hopper Screen (Corn Strainer)

The hopper screen/corn strainer was designed to sift the corn as it is loaded into the hopper. This sifting will catch unwanted materials from being burned. The strainer also includes a removable funnel to aid in fuel handling.

Burnpot Grates

The PC-45 includes two burn grates. You'll notice that they each have different sized air holes in them. Use the grate that fits your fuel the best. In most cases, the smaller holes will be best with corn and the large holes will be best for pellets. Feel free to experiment with both grates.

Options

Room Sensor Installation



Fig. 42

The room sensor is a small temperature sensor on the end of a 60" wire. This sensor is installed much like a standard wall thermostat. Because it is so small, it can be hidden along the trim of a doorway or even up the leg of a coffee table. There is a remote room sensor port on the rear of the unit for easy external connection. Use standard 18-2 thermostat wire to extend the distance to the desired location (100' maximum). The room sensor should be installed in the location where you want to control the temperature.

NOTE: Distances of more than 25 feet from the unit or in another room are not recommended.

It is recommended that the room sensor be installed, even if only installed on the rear of the unit as a return air sensor.

Side Heat Shields

Side heat shields are available to reduce the clearance to combustible materials. See Fig. 43.

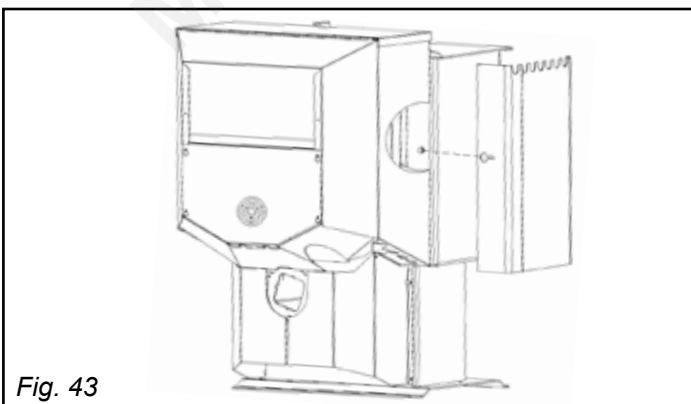

Fig. 43

Hopper Extension

The hopper extension allows you to put more fuel in the hopper which extends burn time on one load of fuel. The hopper extension adds 65 pounds to the existing hopper capacity. The hopper extension secures to the hopper with three latches. There may be some knockouts to remove prior to installation. See Fig. 44.

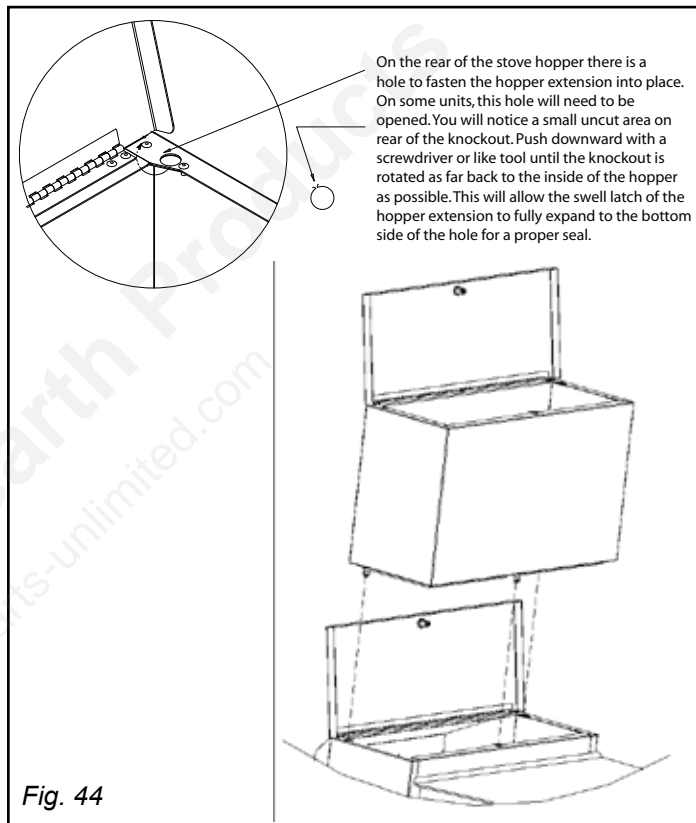
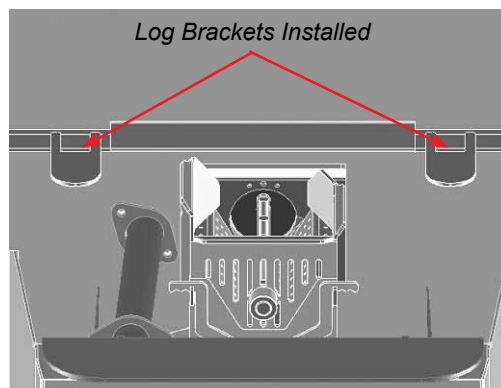

Fig. 44

Ceramic Log Set

There is a 3-piece log set available Item # 3-40-5647. Log bracket # 1-00-724122 is also needed for installation of the log set. In place of the firebricks, the log brackets attach to the brick channel. The logs stack from largest to smallest onto the brick channel and bracket set.



PC 45 Wiring Diagram

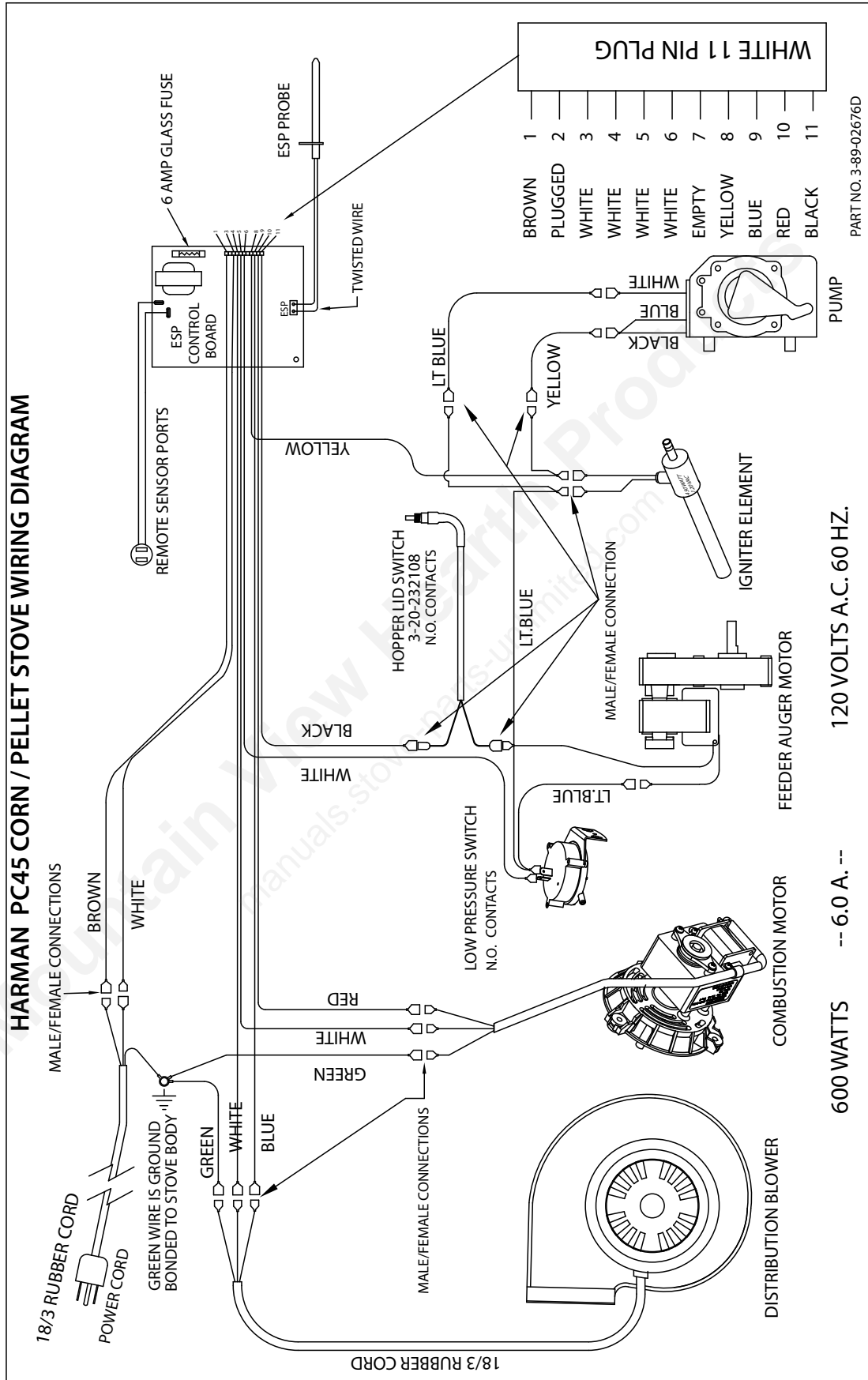

Hearth & Home Technologies Inc. LIMITED LIFETIME WARRANTY

Hearth & Home Technologies Inc., on behalf of its hearth brands ("HHT"), extends the following warranty for HHT gas, wood, pellet, coal and electric hearth appliances that are purchased from an HHT authorized dealer.

WARRANTY COVERAGE:

HHT warrants to the original owner of the HHT appliance at the site of installation, and to any transferee taking ownership of the appliance at the site of installation within two years following the date of original purchase, that the HHT appliance will be free from defects in materials and workmanship at the time of manufacture. After installation, if covered components manufactured by HHT are found to be defective in materials or workmanship during the applicable warranty period, HHT will, at its option, repair or replace the covered components. HHT, at its own discretion, may fully discharge all of its obligations under such warranties by replacing the product itself or refunding the verified purchase price of the product itself. The maximum amount recoverable under this warranty is limited to the purchase price of the product. This warranty is subject to conditions, exclusions and limitations as described below.

WARRANTY PERIOD:

Warranty coverage begins on the date of original purchase. In the case of new home construction, warranty coverage begins on the date of first occupancy of the dwelling or six months after the sale of the product by an independent, authorized HHT dealer/ distributor, whichever occurs earlier. The warranty shall commence no later than 24 months following the date of product shipment from HHT, regardless of the installation or occupancy date. The warranty period for parts and labor for covered components is produced in the following table.

The term "Limited Lifetime" in the table below is defined as: 20 years from the beginning date of warranty coverage for gas appliances, and 10 years from the beginning date of warranty coverage for wood, pellet, and coal appliances. These time periods reflect the minimum expected useful lives of the designated components under normal operating conditions.

Warranty Period		HHT Manufactured Appliances and Venting							Components Covered
Parts	Labor	Gas	Wood	Pellet	EPA Wood	Coal	Electric	Venting	
1 Year		X	X	X	X	X	X	X	All parts and material except as covered by Conditions, Exclusions, and Limitations listed
2 years				X	X	X			Igniters, electronic components, and glass
		X	X	X	X	X			Factory-installed blowers
			X						Molded refractory panels
3 years				X					Firepots and burnpots
5 years	1 year			X	X				Castings and baffles
7 years	3 years		X	X	X				Manifold tubes, HHT chimney and termination
10 years	1 year	X							Burners, logs and refractory
Limited Lifetime	3 years	X	X	X	X	X			Firebox and heat exchanger
90 Days		X	X	X	X	X	X	X	All replacement parts beyond warranty period

See conditions, exclusions, and limitations on next page.

WARRANTY CONDITIONS:

- This warranty only covers HHT appliances that are purchased through an HHT authorized dealer or distributor. A list of HHT authorized dealers is available on the HHT branded websites.
- This warranty is only valid while the HHT appliance remains at the site of original installation.
- Contact your installing dealer for warranty service. If the installing dealer is unable to provide necessary parts, contact the nearest HHT authorized dealer or supplier. Additional service fees may apply if you are seeking warranty service from a dealer other than the dealer from whom you originally purchased the product.
- Check with your dealer in advance for any costs to you when arranging a warranty call. Travel and shipping charges for parts are not covered by this warranty.

WARRANTY EXCLUSIONS:

This warranty does not cover the following:

- Changes in surface finishes as a result of normal use. As a heating appliance, some changes in color of interior and exterior surface finishes may occur. This is not a flaw and is not covered under warranty.
- Damage to printed, plated, or enameled surfaces caused by fingerprints, accidents, misuse, scratches, melted items, or other external sources and residues left on the plated surfaces from the use of abrasive cleaners or polishes.
- Repair or replacement of parts that are subject to normal wear and tear during the warranty period. These parts include: paint, wood, pellet and coal gaskets, firebricks, grates, flame guides, light bulbs, batteries and the discoloration of glass.
- Minor expansion, contraction, or movement of certain parts causing noise. These conditions are normal and complaints related to this noise are not covered by this warranty.
- Damages resulting from: (1) failure to install, operate, or maintain the appliance in accordance with the installation instructions, operating instructions, and listing agent identification label furnished with the appliance; (2) failure to install the appliance in accordance with local building codes; (3) shipping or improper handling; (4) improper operation, abuse, misuse, continued operation with damaged, corroded or failed components, accident, or improperly/incorrectly performed repairs; (5) environmental conditions, inadequate ventilation, negative pressure, or drafting caused by tightly sealed constructions, insufficient make-up air supply, or handling devices such as exhaust fans or forced air furnaces or other such causes; (6) use of fuels other than those specified in the operating instructions; (7) installation or use of components not supplied with the appliance or any other components not expressly authorized and approved by HHT; (8) modification of the appliance not expressly authorized and approved by HHT in writing; and/or (9) interruptions or fluctuations of electrical power supply to the appliance.
- Non-HHT venting components, hearth components or other accessories used in conjunction with the appliance.
- Any part of a pre-existing fireplace system in which an insert or a decorative gas appliance is installed.
- HHT's obligation under this warranty does not extend to the appliance's capability to heat the desired space. Information is provided to assist the consumer and the dealer in selecting the proper appliance for the application. Consideration must be given to appliance location and configuration, environmental conditions, insulation and air tightness of the structure.

This warranty is void if:

- The appliance has been over-fired or operated in atmospheres contaminated by chlorine, fluorine, or other damaging chemicals. Over-firing can be identified by, but not limited to, warped plates or tubes, rust colored cast iron, bubbling, cracking and discoloration of steel or enamel finishes.
- The appliance is subjected to prolonged periods of dampness or condensation.
- There is any damage to the appliance or other components due to water or weather damage which is the result of, but not limited to, improper chimney or venting installation.

LIMITATIONS OF LIABILITY:

- The owner's exclusive remedy and HHT's sole obligation under this warranty, under any other warranty, express or implied, or in contract, tort or otherwise, shall be limited to replacement, repair, or refund, as specified above. In no event will HHT be liable for any incidental or consequential damages caused by defects in the appliance. Some states do not allow exclusions or limitation of incidental or consequential damages, so these limitations may not apply to you. This warranty gives you specific rights; you may also have other rights, which vary from state to state. EXCEPT TO THE EXTENT PROVIDED BY LAW, HHT MAKES NO EXPRESS WARRANTIES OTHER THAN THE WARRANTY SPECIFIED HEREIN. THE DURATION OF ANY IMPLIED WARRANTY IS LIMITED TO DURATION OF THE EXPRESSED WARRANTY SPECIFIED ABOVE.

1-90-06800-2 (Charcoal) (June 2011)
1-90-06800-3 (Goldenfire) (June 2011)
1-90-06800-4 (Metallic Blue) (Jan 2010)

Retired Units

1-90-06800-5 (Honey Glo) (June 2009)
1-90-06800-10 (Mojave Red) Jan 2010
1-90-06800-12 (Forest Green) (Jan 2010)

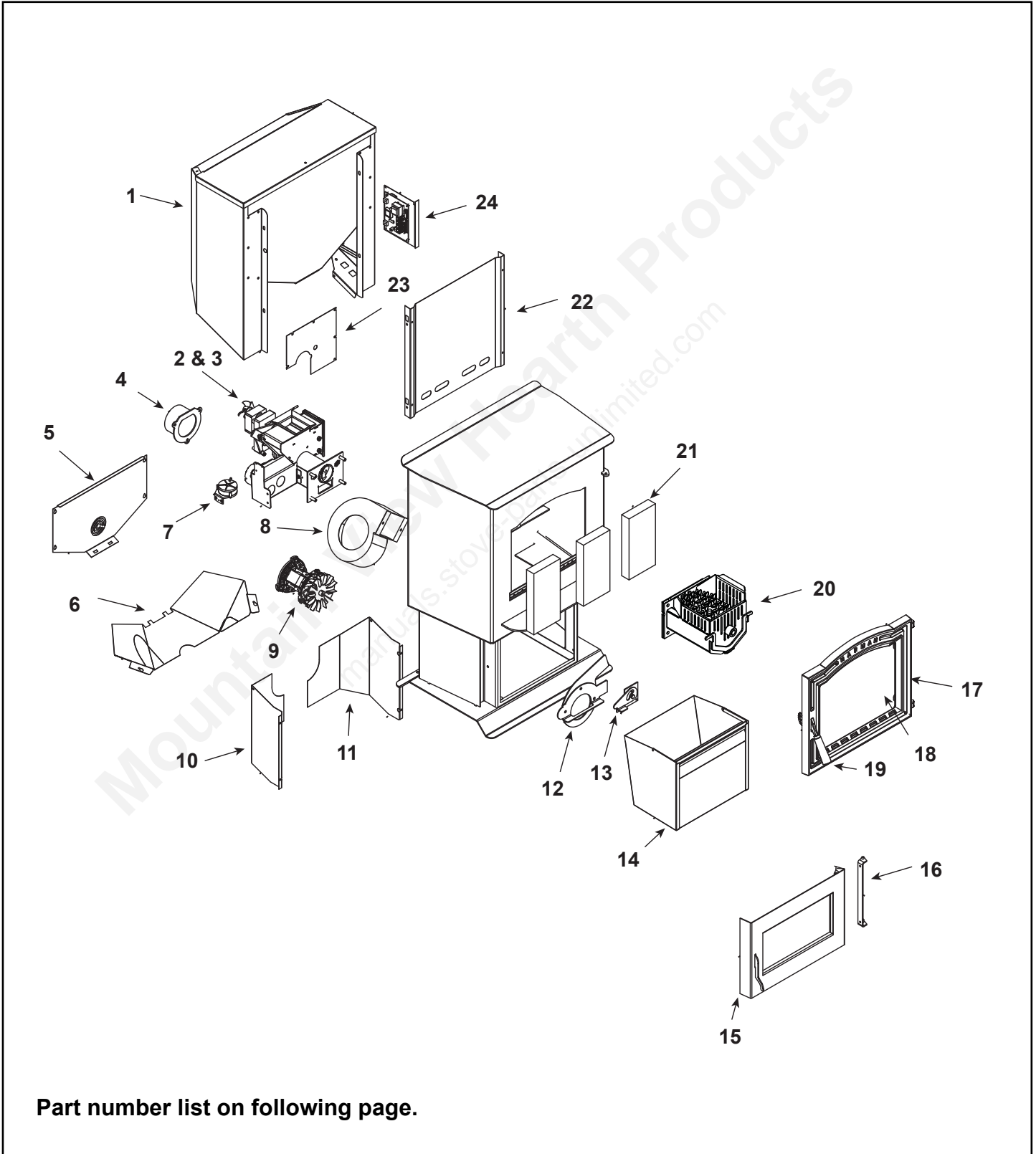

IMPORTANT: THIS IS DATED INFORMATION. When requesting service or replacement parts for your appliance please provide model number and serial number. All parts listed in this manual may be ordered from an authorized dealer.



**Stocked
at Depot**

ITEM	Description	COMMENTS	PART NUMBER	
1	Hopper Assembly	Pre 008055950	1-10-08622	Y
		Post 008055950	1-10-09685A	Y

#2 Feeder Assembly Pre SN #008055950

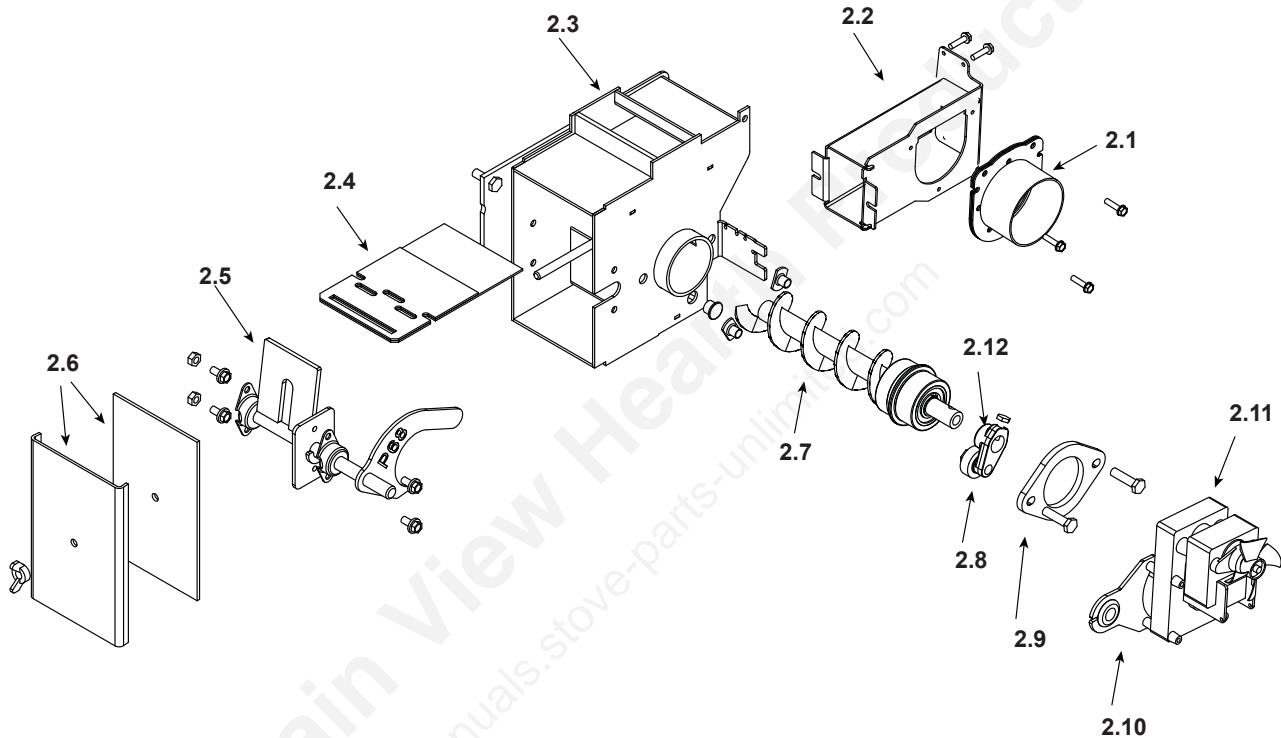

2	Feeder Assembly		1-10-724129A	
2.1	Air Intake Damper		1-10-06466W	
2.2	Air Intake Weldment		1-10-06461	
2.3	Feeder Weldment		1-10-724128	
2.4	Slide Plate Assembly		1-10-08037	Y
2.5	Pusher Arm Assembly		1-10-08535	Y
2.6	Feed Cover and Gasket	2 Sets	1-00-677152	Y
2.7	Auger Assembly		3-50-00465	Y
2.8	Cam Bearing		3-31-3014	Y
2.9	Bearing Flange w/Hardware		1-00-04035	Y
2.10	Bracket, Gear Motor	Pkg of 2	1-00-01534	Y
2.11	Gear Motor, 4 RPM		3-20-60906	Y
2.12	Feeder Cam Block		3-00-00153	Y
	Feeder Air Crossover Kit		1-00-67900	Y
	9 mm Silicone Tubing	5 FT	1-00-511427	Y
	Gasket, Feeder, Air Intake	Pkg of 6	3-44-72224-6	Y

Additional service parts on following page.

#3 Feeder Assembly Post SN #008055950

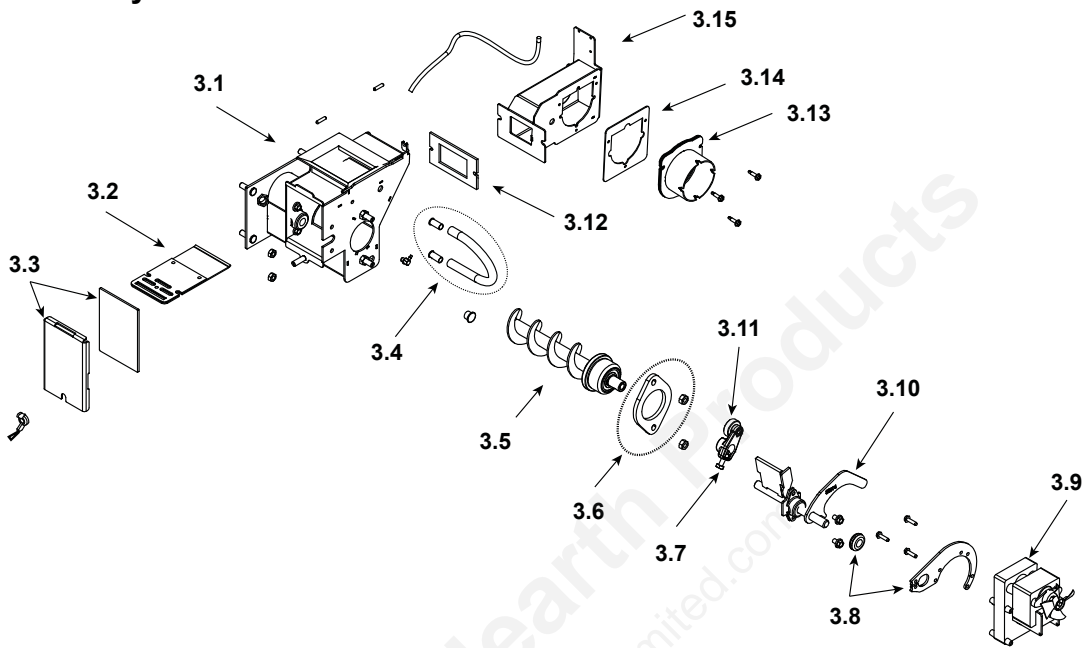

IMPORTANT: THIS IS DATED INFORMATION. When requesting service or replacement parts for your appliance please provide model number and serial number. All parts listed in this manual may be ordered from an authorized dealer.



**Stocked
at Depot**

3	Feeder Assembly		1-10-73505A	
3.1	UL Feeder Body		1-10-73504	
3.2	Slide Plate Assembly		1-10-677121A	Y
3.3	UL Feeder Cover And Gasket	2 Sets	1-00-677122	Y
3.4	Feeder Air Crossover Kit		1-00-67900	Y
	9MM Silicone Tube	5 FT	1-00-511427	Y
3.5	UL Feeder Auger Assembly		3-50-00665	Y
3.6	Bearing Flange w/Hardware		1-00-04035	Y
3.7	UL Cast Cam Block		3-00-677154	Y
3.8	UL Motor Mount W/Grommet		1-00-247406	Y
3.9	Pellet Feeder CW Motor, 4RPM	2 Sets	3-20-60906	Y
3.10	UL Feeder Pusher Arm		1-10-677187W	Y
3.11	Bearing Cam Block		3-31-3014	Y
3.12	Gasket Ultra Air Intake	Pkg of 10	3-44-677160-10	Y
3.13	Pellet Air Intake Assembly		1-10-06810A	
3.14	Gasket Feeder Air Intake	Pkg of 6	3-44-72224-6	Y
3.15	UL Feeder Air Intake		1-10-72222	
4	Flue Tail Pipe		3-00-247237	Y
5	Auger Motor Cover		2-00-02676P	Y
6	Auger Motor Shield		2-00-06467P	Y

Additional service parts on following page.

IMPORTANT: THIS IS DATED INFORMATION. When requesting service or replacement parts for your appliance please provide model number and serial number. All parts listed in this manual may be ordered from an authorized dealer.



**Stocked
at Depot**

ITEM	Description	COMMENTS	PART NUMBER	
7	Differential Switch		3-20-6866	Y
8	Distribution Blower		3-21-22647	Y
9	Combustion Blower		3-21-08639	Y
10	Rear Cover Left		2-00-06468-1P	Y
11	Rear Cover Right		2-00-06468-2P	Y
12	Combustion Intake Weldment. For Corn/Grain		1-10-02677W	Y
	Combustion Intake Weldment, For burning Pellet		1-10-08516S	Y
13	Retainer Assembly, for Combustion Intake Weldment		1-10-08533S	Y
14	Ash Pan		1-10-05800	Y
15	Ash Door Assembly		1-10-06724S	
16	Bolt on Hinge Weldment		2-00-06952B	
17	Cast Door Frame		4-00-06800P	
18	Glass Panel		3-40-950133125	Y
	Glass Clip w/Hardware, (Pkg of 4)	Pre 00855001	1-00-773862	
		Post 00855001	1-00-249140	Y
19	Door Handle Assembly	Pre 1529	1-00-08704	Y
		Post 1529	1-00-453001	Y
	Wooden Handle w/Hardware, Load Door	2 Sets	1-00-00247	Y
<p>#20 Burn Pot</p>				
20	Burn Pot			
20.1	Burn Pot Grate Weldment	Large Hole	1-10-724108	Y
		Small Hole	1-10-724208	
20.2	Burn Pot Housing Weldment		1-10-724103	
20.3	Auger Extension		3-00-02676	Y
20.4	Burn Pot Front Plate	Pkg of 2	2-00-724107-2	Y
	Pellet End Plate		2-00-724111-3	
20.5	Burn Pot Front Plate Lock	Pkg of 5	2-00-724105-5	Y
	Grain Cap		2-00-724205	Y
21	Fire Brick 4-1/2 x 9 x 1-1/4"	Pkg of 7	1-00-900450125	Y
22	Hopper Heat Shield		2-00-06471B	
23	Feeder Cover		2-00-773826L	
24	Circuit Board		1-00-05887	Y
	Circuit Board Plate, Studded w/Label		1-10-02678	
	Knob, Control Board/D-Shaft	25 Sets	1-00-015605	Y

Additional service parts on following page.

IMPORTANT: THIS IS DATED INFORMATION. When requesting service or replacement parts for your appliance please provide model number and serial number. All parts listed in this manual may be ordered from an authorized dealer.



**Stocked
at Depot**

ITEM	Description	COMMENTS	PART NUMBER	
#25 Burn Pot Gasket Placement				
25	Gasket Placement			
25.1	Gasket, Pellet Burn Pot/Tailpipe	Pkg of 5	1-00-07381	Y
25.2	Gasket, Ceramic Insert Plate	Pre 008055950	3-44-724114	Y
25.3	Insert Plate, Ceramic	Pre 008055950	2-00-724104	Y
	Insert Plate, Non-Ceramic	Post 008055950	2-00-73545L	Y
25.4	Insert, Ceramic	Pre 008055950	3-20-05238-10	Y
25.5	Gasket, Burn Pot	Pre 008055950	3-44-724115	Y
	Air Pump		3-20-02679	Y
	Air Pump Filter & Fittings		1-00-02679	Y
	Air Pump Mounting Kit (does not contain air pump)	Pre SN 008055762	1-00-724209	Y
	Air Pump Rebuild Kit		1-00-724135	Y
	Arrow Burn Pot Scraper	Pkg of 10	2-00-773850-10	
	Diagnostic Display Module		3-20-05401	Y
	Draft Meter Assembly		1-00-00637	Y
	Fan Blade, 5" Single Paddle (Combustion Blower)		3-20-40985	Y
	Fuse, 6 Amp	Pkg of 5	3-20-49447-5	Y
	Gasket, 1/4" Rope Black W/PSA (Glass)	15 Ft	1-00-2312	Y
	Gasket, 3/8" Rope White LD (Ash Door or Load Door)	30 Ft	1-00-00888	Y
	Gasket, Hopper	10 Ft	1-00-00248	Y
	Hopper Lid W/Hinge		1-10-09109	Y
	Igniter		3-20-00450	Y
	Igniter Barb Fitting	No longer available	3-10-724203	
	Igniter Mounting Bracket		2-00-724121B	Y
	Latch, Swell/Hopper and Spacer		1-00-199110	Y
	Rubber spacers	Pkg of 10	3-31-901311-10	
	Outside Air Vent		1-10-09542	
	Power Cord		3-20-39685	Y
	Room Sensor		3-20-00906	Y
	Rubber Feet, Air Pump	Pkg of 4	3-20-02679-4	
	Thermister Probe (ESP Probe)	Pre 008055031	3-20-11744	Y
		Post 008055031	3-20-00844	Y
	Touch up Paint, Black	12 oz Can	3-42-1990	
	Wiring Harness, Main		3-20-02680	
	Wiring Harness, Neutral		3-20-02681	

Addendum

Minimizing Smoke During Loss of Power Using Battery Back-up

Harman™ strongly recommends installing battery back-up to minimize entry of smoke into the room in the event of power loss.

Your pellet/biomass burning appliance relies on a combustion blower to remove exhaust. A power failure will cause the combustion blower to stop. This may lead to exhaust seeping into the room. Vertical rise in the venting may provide natural draft. It is, however, no guarantee against leakage.

There are two Harman™ approved battery back-up options for your appliance:

Uninterruptible Power Supply (UPS) UPS battery back-ups are available online or at computer and office equipment stores. Your Harman™ appliance with Rev B or later software available beginning in December 2010 may be plugged directly into a Harman™ approved UPS:

- The APC (American Power Conversion) model #BX1500G and the TrippLite model OMNIVS1500 are tested and approved. Other brands or models may not be compatible.

When power is lost, a fully charged UPS will power a safe, combustion blower only shut-down. Your appliance will pulse the blower every few seconds to clear exhaust until the fire is out. **NOTE: The UPS provides safe shut-down only. It is not intended for continued operation.**

Your appliance will recognize when power is restored. What happens depends on ESP temperature and whether it is equipped with automatic ignition:

- In “Automatic” setting, units equipped with automatic ignition will respond to the set point and ESP temperature and resume normal operation.
- In “Manual” setting:
 - If the ESP is cool, the appliance will remain shut down.
 - If the fire is out and the ESP is still warm, the feeder may restart. Since the fire is out, the ESP temperature will not rise. The unit will then shut-down, and may flash a six-blink status error. (See ESP error codes)
 - If the fire is still burning, it will resume normal operation.

Contact your dealer if you have questions about UPS compatibility with your appliance.

Harman Surefire 512H Battery Back-up The 512H connects to a 12 volt deep cycle battery that will run your appliance for up to eight (8) hours. It includes a trickle charge feature that keeps your battery charged when power is available. **NOTE: If the power is out for longer than battery life, smoke leakage may still occur unless your stove has been safely shut down.**

CAUTION! Always keep appliance doors and hopper lid closed and latched during operation and during power failures to minimize risk of smoke or burn-back.

CAUTION! Use only Harman™ approved battery back-up devices. Other products may not operate properly, can create unsafe conditions or damage your appliance.

Mountain View Hearth Products
manuals.stove-parts-unlimited.com

Mountain View Hearth Products
manuals.stove-parts-unlimited.com

HARMAN[™]

BUILT TO A STANDARD, NOT A PRICE

Proudly Printed On 100% Recycled Paper

