

Models:

**ECO-ADV-PS35
ECO-ADV-PS50
ECO-CAB50**

Pellet Burning Stove

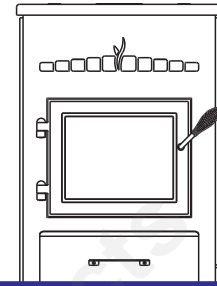
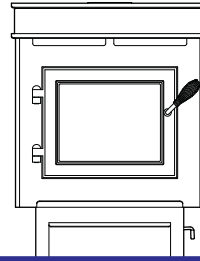
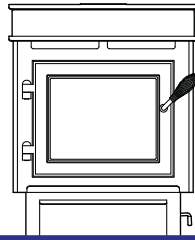

Intertek



Intertek



**Service parts list has been removed from this manual.
Refer to Owner's Manual or individual service parts list.**



DO NOT DISCARD THIS MANUAL

- Important operating and maintenance instructions included.
- Read, understand and follow these instructions for safe installation and operation.
- Leave this manual with party responsible for use and operation.



WARNING



If the information in these instructions is not followed exactly, a fire may result causing property damage, personal injury, or death.

- Do not store or use gasoline or other flammable vapors and liquids in the vicinity of this or any other appliance.
- Do not over fire - If heater or chimney connector glows, you are over firing. Over firing will void your warranty.
- Comply with all minimum clearances to combustibles as specified. Failure to comply may cause house fire.

WARNING



Fire Risk.

Tested and approved for wood pellets. Burning of any other type of fuel will void your warranty.

WARNING



HOT SURFACES!

Glass and other surfaces are hot during operation AND cool down.

Hot glass will cause burns.

- Do not touch glass until it is cooled
- NEVER allow children to touch glass
- Keep children away
- CAREFULLY SUPERVISE children in same room as fireplace.
- Alert children and adults to hazards of high temperatures.

High temperatures may ignite clothing or other flammable materials.

- Keep clothing, furniture, draperies and other flammable materials away.

CAUTION

Check building codes prior to installation.

- Installation MUST comply with local, regional, state and national codes and regulations.
- Consult local building, fire officials or authorities having jurisdiction about restrictions, installation inspection, and permits.

**Read this manual before installing or operating this appliance.
Please retain this owner's manual for future reference.**

Congratulations!

Congratulations on selecting a Heatilator pellet burning appliance. The pellet burning appliance you have selected is designed to provide the utmost in safety, reliability and efficiency.

As the owner of a new pellet burning appliance, you'll want to read and carefully follow all of the instructions contained in this owner's manual. Pay special attention to all cautions and warnings.

This owner's manual should be retained for future reference. We suggest you keep it with your other important documents and product manuals.

Your new pellet burning appliance will give you years of durable use and trouble-free enjoyment. Welcome to the Heatilator family of pellet burning products!



CAUTION: HOT WHILE IN OPERATION DO NOT TOUCH, KEEP CHILDREN, CLOTHING AND FURNITURE AWAY. CONTACT MAY CAUSE SKIN BURNS. SEE NAMEPLATE AND INSTRUCTIONS.

ATTENTION: CHAUD LORS DE L'OPÉRATION. NE PAS TOUCHER. GARDEZ LES ENFANTS ET LES VÊTEMENTS LOIN DE L'ESPACE DÉSIGNÉ DE L'INSTALLATION. LE CONTACT PEUT CAUSER DES BRÛLURES À LA PEAU. VOIR L'ÉTIQUETTE ET LES INSTRUCTIONS.



CAB50 Pellet Stove

SERIAL NO. / NUMÉRO DU
007025

Listed Solid Fuel Room Heater/Pellet Type. Also suitable for Mobile Home Installation. This appliance has been tested and listed for use in Manufactured Homes in accordance with OAR 814-23-9000 through 814-23-909.

Tested to: ASTM E1509-04, ULC S627-00, ULC/ORD-C1482-M1990 Room Heating Pellet Burning Type, (UM) 84-HUD FOR USE ONLY WITH PELLETIZED WOOD. Do not use any other type of fuel. Intertek-Test Laboratories has determined that this appliance complies with Canadian Standards Association (CSA) B415.1 and Title 40 of the U.S. Code of Federal Regulations, Part 60, SubPart AAA.

Input Rating: 50,000 Btu/s/hr. Electrical Rating: 115 VAC, 60 Hz, Start 5.1 Amps, Run 3.0 AMPS. Route power cord away from unit. Do not route cord under or in front of appliance. Do not obstruct the space beneath the heater.

DANGER: Risk of electrical shock. Disconnect power supply before servicing. Replace glass only with 5mm ceramic available from your dealer. To start, set thermostat above room temperature, the stove will light automatically. To shutdown, set thermostat to below room temperature. For further instruction refer to owner's manual. Keep viewing and ash removal doors tightly closed during operation.

PREVENT HOUSE FIRES

Install and use only in accordance with manufacturer's installation and operating instructions. Contact local building or fire officials about restrictions and inspection in your area.

WARNING - FOR MOBILE HOMES: Do not install appliance in a sleeping room. An outside combustion air inlet must be provided. The structural integrity of the mobile home floor, ceiling and walls must be maintained.

Refer to manufacturer's instructions and local codes for precautions required for passing chimney through a combustible wall or ceiling. Inspect and clean vent system frequently in accordance with manufacturer's instructions.

DO NOT CONNECT THIS UNIT TO A CHIMNEY SERVING ANOTHER APPLIANCE. Use a 3" or 4" diameter type "L" or "PL" venting system.

Appareil de chauffage de combustible solide/de type de bouillottes. Accepté dans l'installation dans les maisons mobiles. Cet appareil a été testé et enregistré pour l'usage dans les Maisons Mobiles en accord avec OAR 814-23-9000 jusqu'à 814-23-909.

Testé à: ASTM E1509-04, ULC S627-00, ULC/ORD-C1482-M1990 Room Heating Pellet Burning Type, (UM) 84-HUD POUR USAGE AVEC LES BOULETTES DE BOIS. N'utiliser aucun autre genre de combustible. Intertek-Test Laboratories a déterminé que cet appareil se conforme avec la norme de l'Association Canadienne de normalisation (CSA) B415.1 ainsi que le Titre 40 du Code Fédéral de Régulations des Etats-Unis, partie 60, sous-partie AAA.

Puissance de Rendement: 50,000 Btu/s/hr. Puissance Electrique: 115 VAC, 60 Hz, Début 5.1 Amps, Courir 3.0 Amps.

Eloignez le fil électrique de l'appareil. Ne pas faire passer le fil électrique au dessus ou en dessous de l'appareil. Ne pas bloquer l'espace au dessous de l'appareil.

DANGER: Il y a risque de décharge électrique. Ne pas installer sur une prise de contact avant le service.

Remplacez la vitre seulement avec une vitre céramique de 5mm disponible chez votre fournisseur. Pour allumer, monter la température du thermostat au dessus de la température de la pièce, le poêle s'allumera automatiquement. Pour éteindre, descendre la température du thermostat en dessous de la température de la pièce. Pour des instructions supplémentaires, référez vous au manuel du propriétaire. Gardez la porte d'ouverture et la poignée des cendres fermés hermétiquement durant l'opération.

PREVENTION DES FEUX DE MAISON

Installez et utilisez en accord avec les instructions d'installation et d'opération du fabricant. Contactez le bureau de la construction de votre région pour les restrictions et des inspections d'installation dans votre voisinage. Ne pas installer dans une chambre à coucher. Un tuyau extérieur de combustion doit être installé et ne doit pas être obstrué lorsque l'appareil est en usage. La structure intégrale du bâtiment, y compris les murs, d'une maison mobile doit être maintenue intacte.

Referérez vous aux instructions du fabricant et des codes locaux pour les précautions requises pour passer une cheminée à travers un mur ou un plafond combustibles, et les compensations maximums.

Inspectez et nettoyez la cheminée fréquemment. Ne pas connecter cet appareil à une cheminée servant un autre appareil. Utilisez système de ventilation "L" ou "PL" diamètre 76mm ou 102mm

MINIMUM CLEARANCES TO COMBUSTIBLE MATERIALS / ESPACES LIBRES MINIMUM DES MATÉRIEAUX COMBUSTIBLES:

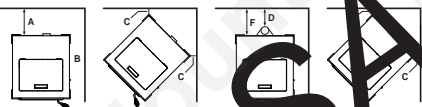

Note 1: In residential installations, when using Parts TPVNT-5, (3" - 3" Top Vent Adapter) and 812-3570 (3" - 6" Offset Adapter), 24 gauge 6" single wall flue connector may be used.

Note 1: Dans les installations résidentielles, lorsque les pièces TPVNT-5, (dessus de l'adaptateur de ventilation 3" - 3") et 812-3570 (le ressaut de l'adaptateur 3" - 6"), un tuyau connecteur de 6" pour mur simple de calibre 24 peut être utilisé.

Note 2: In manufactured home installation, when using Part TPVNT-5, (3" - 3" Top Vent Adapter) and 812-3570 (3" - 6" Offset Adapter), use listed double wall flue connector. An Outside Air Kit, must be used with manufactured home installation.

Note 2: Pour l'installation dans les maisons préfabriquées, lorsque les pièces TPVNT-5, (dessus de l'adaptateur de ventilation 3" - 3") et 812-3570 (le ressaut de l'adaptateur 3" - 6"), utilisez un tuyau connecteur enregistré pour mur double. Un assemblage d'air extérieur, doit être utilisé pour l'installation dans les maisons préfabriquées.

CORNER INSTALLATION / INSTALLATION DU COIN :

C Side Wall / Mur De Côté 2 in [51mm]

VERTICAL 3 in. - 3 in. ADAPTER KIT (PART 811-0860) INSTALLATION:

D Pipe to Back Wall / Un Tuyau Mur Arrière 2 in [25mm]
E Side Wall / Mur De Côté 14 in [356mm]
F Back Wall / Mur Arrière 6.25 in [159mm]

CORNER INSTALLATION WITH VERTICAL ADAPTER KIT:

G Side Wall / Mur De Côté 2 in [51mm]

ALCOVE INSTALLATION / INSTALLATION DE L'ALCÔVE:

Min. Alcove Height: / Une hauteur minimum de l'alcôve 56.75 in [1441mm]
Min. Alcove Side Wall: / Une hauteur minimum mur de côté de l'alcôve 14 in [356mm]
Min. Alcove Width: / Une épaisseur minimum mur de côté de l'alcôve 53 in [1346mm]
Max. Alcove Depth: / La profondeur maximum de l'alcôve 48 in [1219mm]
Max. Mantle Depth: / Profondeur maximum de la mantel de cheminée 36 in [914mm]
Top of Unit to Combustibles: / Vue du haut des matériaux combustibles 21 in [533mm]

FLOOR PROTECTION / PROTECTION DU SOL

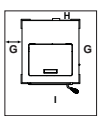

USA
G = 2 in
H = 2 in
I = 6 in
CANADA
G = 203 mm
H = 51 mm
I = 152 mm

Floor protector must be non-combustible material, extending beneath heater and to the front/sides/rear as indicated. Measure front distance (I) from the surface of the glass door.

*Non-combustible floor protection must extend 2 inches [51mm] beneath the flue pipe when installed with horizontal venting or under the Top Vent Adapter with vertical installation. **REQUIRED IN USA; REQUIRED IN CANADA.**

Le poêle doit être placé sur une assise non combustible s'étendant tout autour de lui, comme les schémas l'indiquent. Mesurez la distance du devant (I) de la surface de la porte vitrée.

*Un protecteur incombustible de plancher doit s'étendre 2 inches [51mm] sous le conduit de cheminée pour une installation de ventilation horizontale ou sous un adaptateur de ventilation de dessus pour une installation verticale. **ETATS-UNIS - RECOMMANDE; CANADA - REQUIRMENT.**

Manufactured by/Fabriqué par:

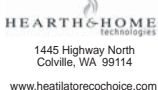

U.S. ENVIRONMENTAL PROTECTION AGENCY
This model is exempt from EPA certification under 40 CFR 60.531 by definition (Wood Heater (A) "Air-to-Fuel Ratio")



Made in U.S.A. of US and imported parts. / Fabriqué aux États-Unis-d'Amérique par des pièces d'origine américaine et pièces importées. 7074-143

SAMPLE: CLEARANCE TO COMBUSTIBLES LABEL
LOCATION: Back of Stove

Serial Number

Model Name

NOTE: Consult insurance carrier, local building inspector, fire officials or authorities having jurisdiction over restrictions, installation inspection and permits.

MANUFACTURED DATE

Safety Alert Key:

- **DANGER!** Indicates a hazardous situation which, if not avoided will result in death or serious injury.
- **WARNING!** Indicates a hazardous situation which, if not avoided could result in death or serious injury.
- **CAUTION!** Indicates a hazardous situation which, if not avoided, could result in minor or moderate injury.
- **NOTICE:** Indicates practices which may cause damage to the fireplace or to property.

TABLE OF CONTENTS

Congratulations	2
Sample of Safety/Serial Number Label	2
Safety Alert Key	3
Warranty.....	4-5

Section 1: Listing and Code Approvals

A. Appliance Certifications.....	6
B. Mobile Home Approved.....	6
C. Glass Specifications.....	6
D. Electrical Rating	6
E. BTU & Efficiency Specifications	6

User's Guide

Section 2: Operating Instructions

A. Your Pellet Appliance, General Operating Parts..	7
B. Fire Safety.....	8
C. Combustible/Non-Combustible Material.....	8
D. Fuel Material & Fuel Storage	8
E. General Operation Information.....	9
F. Before Your First Fire.....	9
G. Hopper Lid Latch and Hopper Switch	9
H. Starting Your First Fire	10
I. Fire Characteristics	10
J. Feed Rate Adjustment	10
K. Ignition Cycles.....	11
L. Clear Space	11

Section 3: Maintaining & Servicing Appliance

A. Proper Shutdown Procedures.....	12
B. Quick Reference Maintenance Chart.....	12
C. General Maintenance & Cleaning	12-15
D. High Ash Fuel Content Maintenance	16
E. Frequently Asked Questions	17

Section 4: Replacement Parts

A. Convection Blower	18
B. Exhaust Blower	19
C. Snap Disc #1, #2, & #3t Replacement	20
D. Igniter Replacement.....	21
E. Baffle Removal & Replace	21
F. Glass Assembly	22

Installer's Guide

Section 5: Getting Started

A. Design, Installation & Location Considerations	23
B. Draft	23
C. Negative Pressure.....	23-24

Section 5: Getting Started (Cont'd)

D. Thermostat Location	24
E. Locating your Appliance & Chimney	24
F. Tools & Supplies Needed.....	25
G. Inspect Appliance and Components	25

Section 6: Dimensions & Clearances

A. Appliance Dimensions.....	26-28
B. Clearances to Combustibles	29
C. Alcove	30
D. Hearth Pad Requirements.....	31

Section 7: Vent Information

A. Chimney & Exhaust Connection	32
B. Venting Termination Requirements.....	32
C. Pellet Venting Charts	33

Section 8: Venting Systems

A. Vertical-Interior	34
B. Through the Wall & Vertical-Exterior.....	34
C. Vertical into Class A Chimney	34
D. Masonry	35
E. Alternate Masonry	35
F. Through the Wall.....	36

Section 9: Mobile Home Installation

Section 10: Appliance Set-Up

A. Outside Air Kit	38
B. Top Vent Adapter	39
C. Rear Vent Adapter	39
D. Thermostat Installation.....	40

Section 11: Troubleshooting

Section 12: Reference Materials

A. Component Functions.....	44-45
B. Component Locations	46
C. Service & Maintenance Log	47
D. Contact Information.....	48

HEATILATOR ECO-CHOICE WARRANTY

Hearth & Home Technologies Inc., on behalf of its hearth brands (“HHT”), extends the following warranty for ECO-CHOICE by heatilator wood and pellet hearth appliances that are purchased from an HHT authorized dealer.

WARRANTY COVERAGE:

HHT warrants to the original owner of the HHT appliance at the site of installation, and to any transferee taking ownership of the appliance at the site of installation within two years following the date of original purchase, that the HHT appliance will be free from defects in materials and workmanship at the time of manufacture. After installation, if covered components manufactured by HHT are found to be defective in materials or workmanship during the applicable warranty period, HHT will, at its option, repair or replace the covered components. HHT, at its own discretion, may fully discharge all of its obligations under such warranties by replacing the product itself or refunding the verified purchase price of the product itself. The maximum amount recoverable under this warranty is limited to the purchaser price of the product. This warranty is subject to conditions, exclusions and limitations as described below.

WARRANTY PERIOD:

Warranty coverage begins on the date of original purchase. In the case of new home construction, warranty coverage begins on the date of first occupancy of the dwelling or six months after the sale of the product by an independent, authorized HHT dealer/distributor, whichever occurs earlier. The warranty shall commence no later than 24 months following the date of product shipment from HHT, regardless of the installation or occupancy date. The warranty period for parts and labor for covered components is produced in the following table.

Warranty Period		Heatilator ECO-CHOICE Appliances		Components Covered
Parts	Labor	Pellet	EPA Wood	
1 year		X	X	All parts and material except as covered by Conditions, Exclusions, and Limitations listed
3 years		X		Firepots and burnpots
3 years	1 year	X	X	Castings
5 years	3 years		X	Manifold tubes
5 years	3 years	X	X	Firebox and heat exchanger
90 days		X	X	All replacement parts beyond warranty period

See conditions, exclusions, and limitations on next page

WARRANTY COVERAGE:

- This warranty only covers HHT appliances that are purchased through an HHT authorized dealer or distributor. A list of HHT authorized dealers is available on the HHT branded websites.
- This warranty is only valid while the HHT appliance remains at the site of original installation.
- Contact your installing dealer for warranty service. If the installing dealer is unable to provide necessary parts, contact the nearest HHT authorized dealer or supplier. Additional service fees may apply if you are seeking warranty service from a dealer other than the dealer from whom you originally purchased the product.
- Check with your dealer in advance for any costs to you when arranging a warranty call. Travel and shipping charges for parts are not covered by this warranty.

WARRANTY EXCLUSIONS:

This warranty does not cover the following:

- Changes in surface finishes as a result of normal use. As a heating appliance, some changes in color of interior and exterior surface finishes may occur. This is not a flaw and is not covered under warranty.
- Damage to printed, plated, or enameled surfaces caused by fingerprints, accidents, misuse, scratches, melted items, or other external sources and residues left on the plated surfaces from the use of abrasive cleaners or polishes.
- Repair or replacement of parts that are subject to normal wear and tear during the warranty period. These parts include: paint, wood, pellet and coal gaskets; firebricks; grates; flame guides; light bulbs; batteries and the discoloration of glass.
- Minor expansion, contraction, or movement of certain parts causing noise. These conditions are normal and complaints related to this noise are not covered by this warranty.
- Damages resulting from: (1) failure to install, operate, or maintain the appliance in accordance with the installation instructions, operating instructions, and listing agent identification label furnished with the appliance; (2) failure to install the appliance in accordance with local building codes; (3) shipping or improper handling; (4) improper operation, abuse, misuse, continued operation with damaged, corroded or failed components, accident, or improperly/incorrectly performed repairs; (5) environmental conditions, inadequate ventilation, negative pressure, or drafting caused by tightly sealed constructions, insufficient make-up air supply, or handling devices such as exhaust fans or forced air furnaces or other such causes; (6) use of fuels other than those specified in the operating instructions; (7) installation or use of components not supplied with the appliance or any other components not expressly authorized and approved by HHT; (8) modification of the appliance not expressly authorized and approved by HHT in writing; and/or (9) interruptions or fluctuations of electrical power supply to the appliance.
- Non-HHT venting components, hearth components or other accessories used in conjunction with the appliance.
- Any part of a pre-existing fireplace system in which an insert or a decorative gas appliance is installed.
- HHT's obligation under this warranty does not extend to the appliances' capability to heat the desired space. Information is provided to assist the consumer and the dealer in selecting the proper appliance for the application. Consideration must be given to appliance location and configuration, environmental conditions, insulation and air tightness of the structure.

This warranty is void if:

- The appliance has been over-fired or operated in atmospheres contaminated by chlorine, fluorine, or other damaging chemicals. Overfiring can be identified by, but not limited to, warped plates or tubes, rust colored cast iron, bubbling, cracking and discoloration of steel or enamel finishes.
- The appliance is subjected to prolonged periods of dampness or condensation.
- There is any damage to the appliance or other components due to water or weather damage which is the result of, but not limited to improper chimney or venting installation.

WARRANTY EXCLUSIONS:

- The owner's exclusive remedy and HHT's sole obligation under this warranty, under any other warranty, express or implied, or in contract, tort or otherwise, shall be limited to replacement, repair, or refund, as specified above. In no event will HHT be liable for any incidental or consequential damages caused by defects in the appliance. Some states do not allow exclusions or limitation of incidental or consequential damages, so these limitations may not apply to you. This warranty gives you specific rights; you may also have other rights, which vary from state to state. EXCEPT TO THE EXTENT PROVIDED BY LAW, HHT MAKES NO EXPRESS WARRANTIES OTHER THAN THE WARRANTY SPECIFIED HEREIN. THE DURATION OF ANY IMPLIED WARRANTY IS LIMITED TO DURATION OF THE EXPRESSED WARRANTY SPECIFIED ABOVE.

1 Listing and Code Approvals

A. Appliance Certification

Models:	ECO-ADV-PS35, ECO-ADV-PS50 and ECO-CAB50
Laboratory:	Intertek
Report No.	3198406
Type:	Solid Fuel Room Heater/Pellet Fuel Burning Type
Standard:	ASTM E1509-04 and ULC S627-00, ULC/ORD-C1482-M1990 Room Heater Pellet Fuel Burning type and (UM) 84-HUD, Mobile Home Approved.

NOTE: This installation must conform with local codes. In the absence of local codes you must comply with the **ASTM E1509-04, ULC S627-00, ULC/ORD-C-1482-M1990, (UM) 84-HUD,**

These heaters meet the US Environmental Protection Agency's emissions limits for pellet heaters. Under specific conditions the PS35 stove has been shown to deliver heat at rates ranging from 9,200 to 24,400 BTU/hr. The PS50 and CAB50 stoves have been shown to deliver heat at rates ranging from 11,900 to 31,400 BRU/hr.

B. Mobile Home Approved

- This appliance is approved for mobile home installations when not installed in a sleeping room and when an outside combustion air inlet is provided.
- The structural integrity of the mobile home floor, ceiling, and walls must be maintained.
- The appliance must be properly grounded to the frame of the mobile home with #8 copper ground wire, and use only listed double-wall connector pipe.
- Outside Air Kit, part 811-0872 or OAK-3 must be installed in a mobile home installation.

Note: The appliance is also approved for installation into a shop.

C. Glass Specifications

This appliance is equipped with 5mm ceramic glass. Replace glass only with 5mm ceramic glass. Please contact your dealer for replacement glass.

D. Electrical Rating (On High)

Model PS35: 115 VAC, 60 Hz, Start 3.8 Amps, Run 1.3 Amps

Model PS50: 115 VAC, 60 Hz, Start 5.1 Amps, Run 3.0 Amps

Model CAB50: 115 VAC, 60 Hz, Start 5.1 Amps, Run 3.0 Amps

Heatilator is a registered trademark of Hearth & Home Technologies.

E. BTU & Efficiency Specifications

*BTU input will vary, depending on the brand of fuel you use in your stove. Consult your dealer for best results.

MODEL: PS35	
Particulate Emissions Rating:	2.1 grams / hr
*BTU Output:	9,200 - 24,400 / hr
Heating Capacity:	750 to 1450 sq. ft. depending on climate zone
Hopper Capacity: (Approx)	45 lbs
Fuel:	Wood Pellets
Shipping Weight:	210 lbs
Efficiency:	78%

MODEL: PS50 / CAB50	
Particulate Emissions Rating:	1.7 grams / hr
*BTU Output:	11,900 - 31,400 / hr
Heating Capacity:	1225 to 2200 sq. ft. depending on climate zone
Hopper Capacity: (Approx)	83 lbs / 120 lbs
Fuel:	Wood Pellets
Shipping Weight:	240 lbs / 266 lbs
Efficiency:	78%

WARNING! Risk of Fire! Hearth & Home Technologies disclaims any responsibility for, and the warranty and agency listing will be voided by the below actions.

DO NOT:

- Install or operate damaged appliance
- Modify appliance
- Install other than as instructed by Hearth & Home Technologies
- Operate the appliance without fully assembling all components
- Over fire
- Install any component not approved by Hearth & Home Technologies
- Install parts or components not Listed or approved
- Disable safety switches

Improper installation, adjustment, alteration, service or maintenance can cause injury or property damage.

For assistance or additional information, consult a qualified installer, service agency or your dealer.

NOTE: Hearth & Home Technologies, manufacturer of this appliance, reserves the right to alter its products, their specifications and/or price without notice.

User Guide

2 Operating Instructions

⚠ WARNING



HOT SURFACES!

Glass and other surfaces are hot during operation AND cool down.

Hot glass will cause burns.

- **DO NOT** touch glass until it is cooled
- NEVER allow children to touch glass
- Keep children away
- CAREFULLY SUPERVISE children in same room as appliance.
- Alert children and adults to hazards of high temperatures.

High temperatures may ignite clothing or other flammable materials.

- Keep clothing, furniture, draperies and other flammable materials away.

NOTICE: If you expect that children may come into contact with this appliance, we recommend a barrier such as a decorative screen. See your dealer for suggestions.

A. Your Pellet Appliance - General Operating Parts

WARNING! DO NOT operate appliance before reading and understanding operating instructions. Failure to operate appliance according to operating instructions could cause fire or injury.

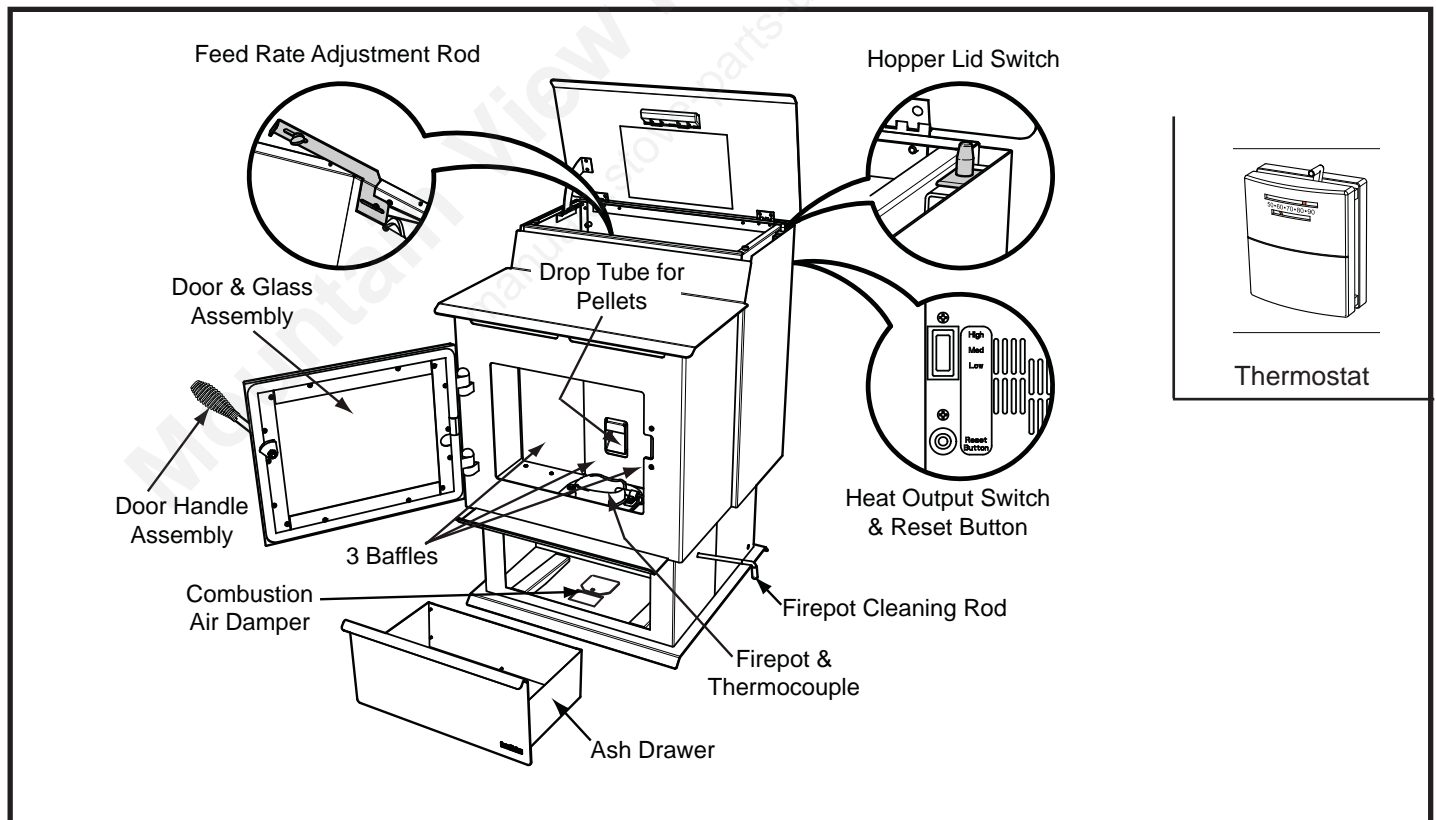

Figure 7.1 - General Operating Parts

The illustration is intended to show an overview of the operating parts for your stove. The appearance of your appliance may vary slightly. For specific part numbers and locations for your model, see the exploded view drawings in the back of the manual.

B. Fire Safety

To provide reasonable fire safety, the following should be given serious consideration:

- Install at least one smoke detector on each floor of your home.
- Locate smoke detector away from the heating appliance and close to the sleeping areas.
- Follow the smoke detector manufacturer's placement and installation instructions and maintain regularly.
- Conveniently locate a Class A fire extinguisher to contend with small fires.
- In the event of a hopper fire:
 - Evacuate the house immediately.
 - Notify fire department.

C. Combustible/Non-Combustible Materials

• **Combustible Material**

Material made of or surfaced with wood, compressed paper, plant fibers, plastics, or any material capable of igniting and burning, whether flame-proofed or not, plastered or unplastered.

• **Non-combustible Material**

Material which will not ignite and burn. Such materials are those consisting entirely of steel, iron, brick, tile, slate, glass or plasters, or any combination thereof.

• **Non-combustible Sealant Material**

Sealants which will not ignite and burn: Rutland, Inc. Fireplace Mortar #63, Rutland 76R, Nuflex 304, GE RTV106 or GE RTB116 (or equivalent).

D. Fuel Material and Fuel Storage

Pellet fuel quality can greatly fluctuate. We recommend that you buy fuel in multi-ton lots whenever possible. However, we do recommend trying various brands before purchasing multi-ton lots to ensure your satisfaction.

Fuel Material

- Made from sawdust or wood by-products
- Depending on the source material it may have a high or low ash content.

Higher Ash Content Material

- Hardwoods with a high mineral content
- Fuel that contains bark
- Standard grade pellets or high ash pellets

Lower Ash Content Material

- Most softwoods
- Fuels with low mineral content
- Most premium grade pellets

Clinkers

Minerals and other non-combustible materials such as sand will turn into a hard, glass-like substance called a clinker when heated in the firepot.

Trees from different areas will vary in mineral content. That is why some fuels produce more clinkers than others.

Moisture

Always burn dry fuel. Burning fuel with high moisture content takes heat from the fuel and tends to cool the appliance, robbing heat from your home. Damp pellet fuel can clog the feed system.

Size

- Pellets are either 1/4 inch or 5/16 inch (6-8mm) in diameter
- Length should be no more than 1-1/2 inches (38mm)
- Pellet lengths can vary from lot to lot from the same manufacturer
- Due to length variations, the feed rate may need adjusting occasionally

Performance

- Higher ash content requires the firepot and the ash drawer to be emptied more frequently
- Hardwoods require more air to burn properly
- Premium wood pellets produce the highest heat output
- Burning pellets longer than 1-1/2 inches (38mm) can cause an inconsistent fuel feed rate and/or missed ignitions

Storage

- Wood pellets should be left in their original sealed bag until using to prevent moisture absorption
- Do not store any pellet fuel within the clearance requirements or in an area that would hinder routine cleaning and maintenance

E. General Operating Information

1. Thermostat Calls For Heat

The appliance is like most modern furnaces; when the thermostat calls for heat, your appliance will automatically light and deliver heat.

When the room is up to temperature and the thermostat is satisfied, the red call light will go off and the appliance will shut down.

2. Heat Output Controls

This appliance is equipped with a heat output control switch that has three settings or burn rates; low, medium and high. **Figure 9.1.**

The appliance will turn on and off as the thermostat demands. When the thermostat calls for heat, the appliance will start up at the burn rate for which it is set. If the appliance is set at one of the lower settings, it will run quieter but take longer to heat up an area than if it were set at a higher burn rate.

Regardless of the burn rate, when the area is warm enough to satisfy the thermostat, the appliance will shut off.

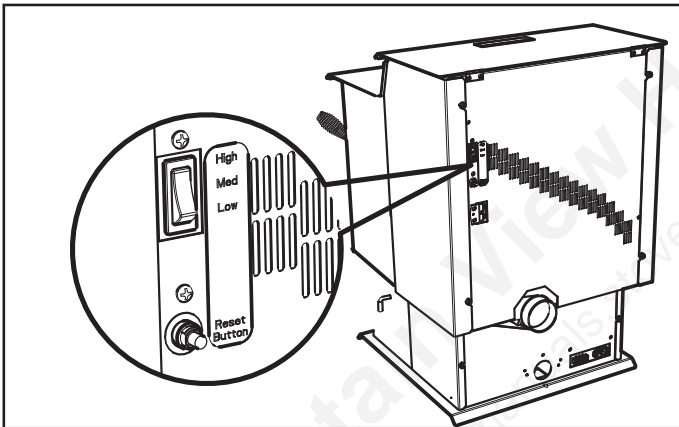

Figure 9.1

WARNING



Fire Hazard.

Keep combustible materials, gasoline and other flammable vapors and liquids clear of appliance.

- Do NOT store flammable materials in the appliance's vicinity.
- DO NOT USE GASOLINE, LANTERN FUEL, KEROSENE, CHARCOAL LIGHTER FLUID OR SIMILAR LIQUIDS TO START OR "FRESHEN UP" A FIRE IN THIS HEATER.
- DO NOT BURN GARBAGE OR FLAMMABLE FLUIDS SUCH AS GASOLINE, NAPHTHA OR ENGINE OIL.
- DO NOT USE CHEMICALS OR FLUIDS TO START THE FIRE.
- Keep all such liquids well away from the heater while it is in use.
- Combustible materials may ignite.

F. Before Your First Fire

1. First, make sure your appliance has been properly installed and that all safety requirements have been met. Pay particular attention to the fire protection, venting and thermostat installation instructions.
2. Double check that the ash drawer and firebox are empty!
3. Close and latch the door.

NOTICE: The tip of the thermocouple must be in contact with the inside end of the thermocouple cover or missed ignitions can occur.

G. Hopper Lid Latch and Hopper Switch

1. Lift up the hopper lid and lock into open position. Now you can fill the hopper with fuel.
2. The hopper switch is designed to shut down the feed motor when the hopper lid is open. Leaving the lid open too long can cause the fire to go out. **Figure 9.2.**
3. To close the hopper lid, while holding lid open with one hand, push the bottom of the latch inwards to release from locked position and then slowly close the hopper lid. **Figure 9.3.**

Note: The CAB50 has no hopper lid latch. The hopper switch is located in a similar location and is activated by a magnet attached to the Hopper Lid.

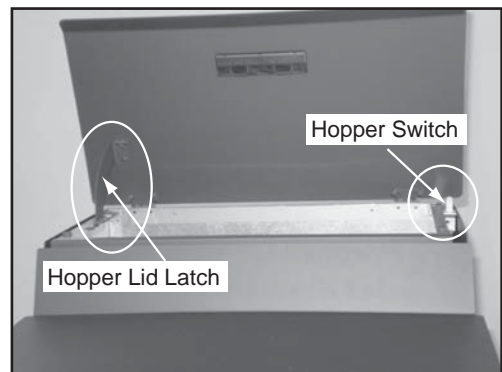

Figure 9.2

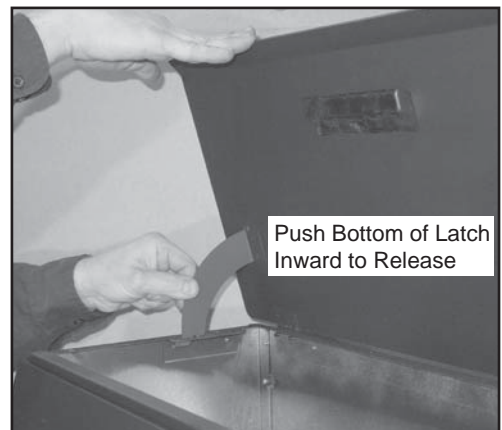

Figure 9.3

H. Starting Your First Fire

1. A thermostat is required for proper operation of this appliance. If you have to adjust the feed rate after you have started the fire, most of the pellets in the hopper will need to be removed so start out with filling the hopper approximately 1/4 full at this time. Set the thermostat to its lowest setting and plug the power cord into nearby outlet.
2. The exhaust blower will stay on for approximately 18 minutes even though the thermostat is not calling for heat. This is normal.
3. Locate the heat output control switch mounted on the back of the appliance in the upper left corner. **Figure 9.1 on page 9.**
Turn it to the “high” setting by pushing the top of the control switch in and then adjust the thermostat to its highest setting.
4. Look through the hole in the left lower side panel and you will see the red call light on the control box will be on. **Figure 10.1.** This indicates the thermostat is calling for heat. On the CAB50 the light can be viewed from behind through the hole near the bottom left side of the rear panel.
5. The fuel feed system and the igniter should now be on.
6. For your first fire it will be necessary to press the reset button once approximately 2 minutes after start up and again in 5 minutes. This will fill the feed system and allow the appliance to begin dropping pellets. Or you can put a handful of pellets in the firepot to speed up the process. The appliance will continue to run as long as the thermostat is calling for heat.
7. Once the appliance has ignited, let it burn for approximately 15 minutes, then set the thermostat to the desired room temperature. Adjust the heat output control switch to the desired setting.

CAUTION

Odors and vapors released during initial operation.

- Curing of high temperature paint.
- Open windows for air circulation.

Odors may be irritating to sensitive individuals.

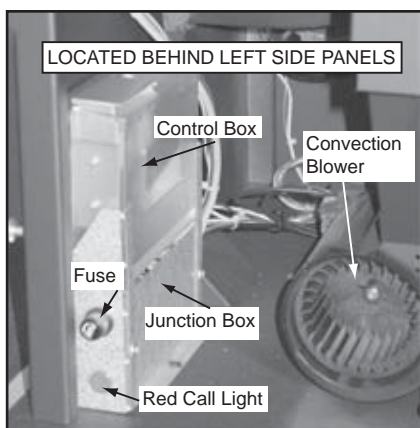

Figure 10.1

I. Fire Characteristics

A properly adjusted fire with the heat output control switch set on “high” has a short active flame pattern that extends out of the firepot approximately 4 to 8 inches (102 to 203mm).

If the fire has tall flames with black tails and seems somewhat lazy, the feed rate will need to be reduced. This is done by sliding the fuel adjustment control rod down, which will reduce the feed. **Figure 10.3.**

If the fire is not 4 to 8 inches (102 to 203mm) tall, slide the fuel adjustment control rod up to increase the feed. A medium and low setting will give a shorter flame. The flame will rise and fall somewhat. This is normal.

J. Feed Rate Adjustment Instructions

The feed adjustment control rod is factory set, and should be adequate for most fuels. However, if the flame height is too high or too low, you will need to adjust the feed rate. Wait until the appliance has been burning for 15 minutes before making your adjustments and allow 15 minutes for feed adjustment to take effect.

1. Loosen the thumb screw.
2. Pull the feed adjustment control rod up to increase the feed rate and flame height or push down to decrease the feed rate and flame height.
3. Re-tighten the thumb screw. A new stove has a break in period. The fire characteristics should be checked again after 5 bags of pellets and adjustments made if necessary.

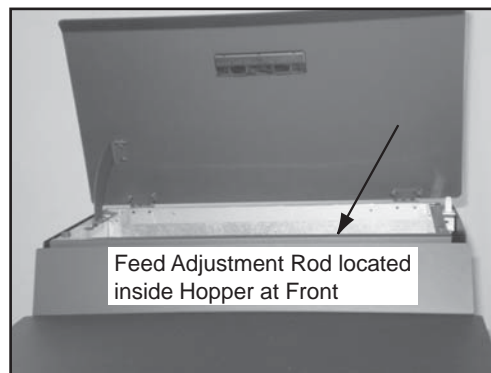

Figure 10.2

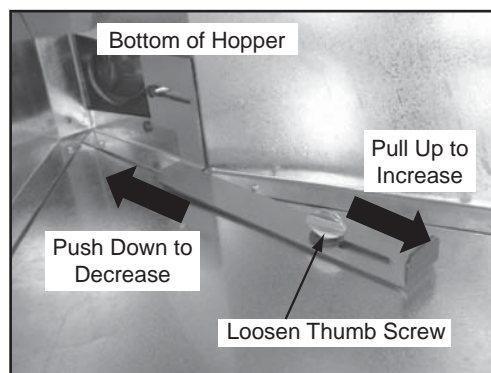

Figure 10.3

K. Ignition Cycles

1. At the beginning of each ignition cycle, it is normal to see some smoke in the firebox. The smoke will stop once the fire starts.
2. The convection blower will automatically turn on after your appliance has been burning for approximately 10 minutes.

This blower transfers heat from your appliance into the room, and will continue to run after the thermostat has stopped calling for heat until the appliance has cooled down.

3. Occasionally the appliance may run out of fuel and shut itself down. When this happens, the red call light will be on. **See Figure 10.1, page 10.**

To restart it, fill the hopper and press the reset button. When you press the reset button the red call light will go out. Release the button and the light will come back on. Continue pushing the button once a minute until pellets begin to fall into the firepot.

You should see a fire shortly. If not, follow the instructions on **page 10**, for "Starting Your First Fire".

L. Clear Space

WARNING! RISK OF FIRE! Do NOT place combustible objects in front or to the sides of the appliance. High temperatures may ignite clothing, furniture or draperies.



Mantel: Avoid placing candles and other heat-sensitive objects on mantel or hearth. Heat may damage these objects.

NOTICE: Clearances may only be reduced by means approved by the regulatory authority having jurisdiction.

WARNING! RISK OF FIRE! Keep combustible materials, gasoline and other flammable vapors and liquids clear of appliance.

- Do **NOT** store flammable materials in the appliance's vicinity.
- Do **NOT** use gasoline, lantern fuel, kerosene, charcoal lighter fluid or similar liquids to start or "freshen up" a fire in this heater.

Keep all such liquids well away from the heater while it is in use as combustible materials may ignite.

 WARNING	
	Fire Risk Do NOT operate appliance: <ul style="list-style-type: none">• With appliance door open.• Firepot floor open.
	Do NOT store fuel: <ul style="list-style-type: none">• Closer than required clearances to combustibles to appliance• Within space required for loading or ash removal.

3 Maintaining & Servicing Your Appliance

A. Proper Shutdown Procedure

⚠ CAUTION

Shock and Smoke Hazard

- Turn down thermostat, let appliance completely cool and exhaust blower must be off. Now you can unplug appliance before servicing.
- Smoke spillage into room can occur if appliance is not cool before unplugging.
- Risk of shock if appliance not unplugged before servicing appliance.

C. General Maintenance

1. Types of Fuel

Depending on the type of fuel you are burning will dictate how often you have to clean your firepot.

If the fuel you are burning has a high dirt or ash content, it may be necessary to clean the firepot more than once a day.

Dirty fuel will cause clinkers to form in the firepot. A clinker is formed when dirt, ash or a non-burnable substance is heated to 2000°F (1093°C) and becomes glass-like. See "D" **page 16** in this section for more details on fuels with high ash content.

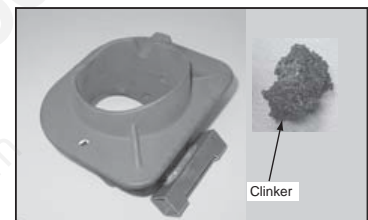

Figure 12.1 - Clinker

Follow the detailed instructions found in this section for each step listed as referenced in the chart below.

B. Quick Reference Maintenance Chart

Cleaning or Inspection	Frequency		Daily	Weekly	Monthly	Yearly
Ash Drawer	Every 5 bags of fuel	OR		X		
Ash Removal from Firebox	Every 5 bags of fuel or more frequently depending on ash build-up	OR		X		
Blower, Exhaust	More frequently depending on the fuel type	OR				X
Blower, Convection	Every 25 bags or more frequently depending on operating environment.	OR			X	
Door Handle & Gasket Inspection	Prior to heating season	OR			X	
Exhaust Path, Drop Tube and Behind Baffles	Every 25 bags or more frequently depending on ash build-up	OR			X	
Firepot Cleaning Rod	Every 1 bag of fuel	OR	X			
Firepot with Clean-out Tool	Every 5 bags of fuel	OR		X		
Firebox - Prepare for Non-Burn Season	At end of heating season	OR				X
Glass	When clear view of firepot becomes obscure	OR		X		
Hopper	Every 50 bags of fuel	OR			X	
Top Vent Adapter	More frequently depending on ash build-up	OR				X
Venting System	Every 3 tons or more frequently depending on the fuel type	OR				X

NOTICE: These are recommendations. Clean more frequently if you encounter heavy build-up of ash at the recommended interval or you see soot coming from the vent. **Not properly cleaning your appliance on a regular basis will void your warranty.**

WARNING

Fire Risk



- NEVER pull firepot cleaning rod out when appliance is operating.
- Cleaning Rod MUST be completely pushed in before operating appliance.
- Hot pellets may fall into ashpan and start a fire or mis-starts due to lack of vacuum.

2. Cleaning Firepot with Cleaning Rod & Firepot Clean-Out Tool:

- **Frequency:** Daily or more often as needed
 - **By:** Homeowner
- a. The appliance must be in complete shutdown and cool and the exhaust blower off. If you are just cleaning the firepot, there is no need to unplug the appliance.
 - b. Locate the firepot cleaning rod on the right side of the appliance. **Figure 13.1.** When you pull the cleaning rod straight out it will slide open the firepot floor to allow the ashes to be deposited in the ash drawer. You will see the light color painted area on the cleaning rod to let you know the rod is in OPEN position. **Figure 13.2.**
 - c. Pull the firepot cleaning rod OUT and IN a couple of times to help shake debris loose. If the rod is hard to pull, it may be necessary to use your firepot clean-out tool to chip away material that has built up on the bottom plate of the firepot and to push out any clinkers while in the open position.
 - d. To close the firepot floor: **slightly raise the cleaning rod** and then push it back into place. If you have closed the cleaning rod properly (pushed all the way in) you will not see any of the light color painted area. **Figure 13.2.**
 - e. Always have the ash drawer in place before pulling the firepot cleaning rod, otherwise the ashes will fall down and fill the outside air opening and the appliance will produce soot out of the exhaust and will affect efficiency.

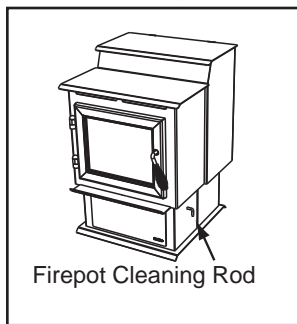

Figure 13.1

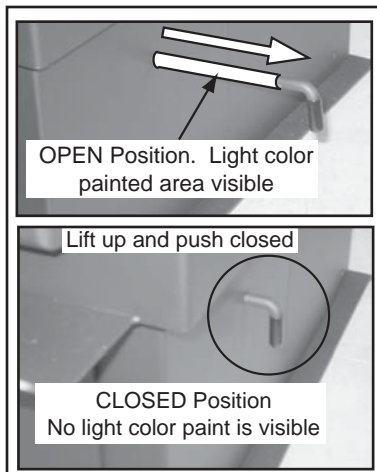

Figure 13.2

3. Ash Removal from Firebox

- **Frequency:** Weekly or more frequently depending on ash build-up.
 - **By:** Homeowner
- a. There must not be any hot ashes in the firebox during cleaning so allow the appliance to completely cool. The firebox ash should be removed every time the exhaust path is cleaned. Frequent cleaning of the ash in the firebox will help slow down the build-up of ash in the exhaust blower and vent system.
 - b. Vacuum out the firebox thoroughly on both sides of the firebox and the floor and ceiling. The ash drawer should be emptied every time you clean the firebox. Remember to place the ash and debris into a metal or non-combustible container. **See Disposal of Ashes. (Pg 14)**
 - c. Always have the ash drawer in place before pulling the firepot cleaning rod, otherwise the ashes will fall down and fill the outside air opening and the appliance will produce soot out of the exhaust and will affect efficiency.

WARNING



Burn Risk

- NEVER remove ash drawer while appliance is operating.

4. Cleaning Ash Drawer

- **Frequency:** Weekly or every 5 bags of fuel
 - **By:** Homeowner
- a. There must not be any hot ashes in the ash drawer when you empty it, so allow the appliance to completely cool.
 - b. Locate the ash drawer underneath the firepot. Slide the ash drawer straight out. Empty into a non-combustible container and re-install the ash drawer. **See Disposal of Ashes. (Pg 14)**
 - b. Always have the ash drawer in place before pulling the firepot cleaning rod, otherwise the ashes will fall down and fill the outside air opening and the appliance will produce soot out of the exhaust and will affect efficiency.

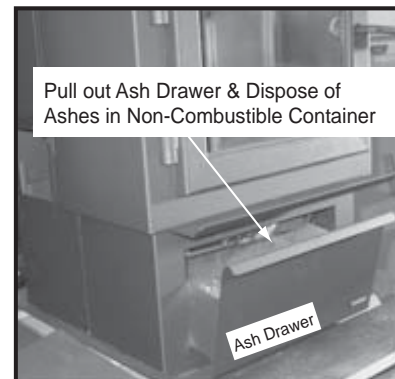



Figure 13.3

5. Disposal of Ashes

- **Frequency:** As needed
- **By:** Homeowner

Ashes should be placed in a metal container with a tight-fitting lid. The closed container of ashes should be placed on a non-combustible floor or on the ground, well away from all combustible materials, pending final disposal.

If the ashes are disposed of by burial in soil or otherwise locally dispersed, they should be retained in the closed container until all cinders have been thoroughly cooled.

**WARNING**



Disposal of Ashes

- Ashes should be placed in metal container with tight fitting lid.
- Ashes should be retained in closed container until all cinders have thoroughly cooled.

6. Cleaning the Exhaust Path, Baffles & Drop Tube

- **Frequency:** Monthly or every 25 bags or more frequently depending on ash build-up.
- **By:** Homeowner
 - a. Appliance must be completely cool.
 - b. Open the door and remove the center baffle first and then the right and left baffles. See Baffle Removal Instructions on **page 21**. Thoroughly vacuum the exhaust path and drop tube and continue throughout the rest of the firebox. Also vacuum the front and back of the baffles.
 - c. Also vacuum the convection blower impellers or use a soft brush to remove any ash build-up.
 - c. Replace the right and left baffles and then the center baffle and close and latch the door.

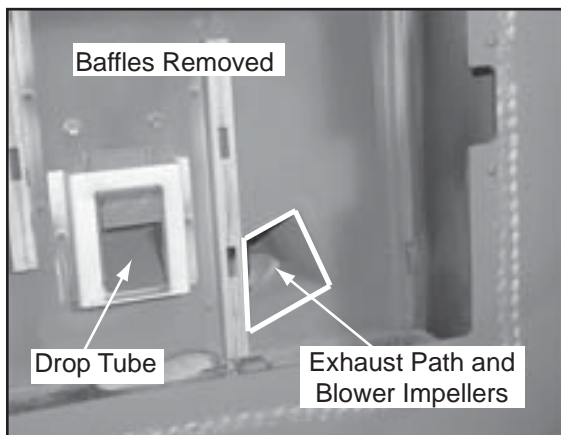

Figure 14.1

7. Cleaning the Hopper

- **Frequency:** Monthly or after burning 50 bags of fuel
- **By:** Homeowner

After burning approximately 50 bags of fuel you will need to clean the hopper to prevent sawdust build-up.

A combination of sawdust and pellets on the bottom end of the auger reduces the amount of fuel supply to the firepot. This can result in nuisance shutdowns and mis-starts.

- a. The appliance must be in complete shutdown. Allow the appliance to completely run out of pellets and cool down.
- b. Empty the hopper of any remaining pellets.
- c. Vacuum the hopper and feed tube.

NOTE: Hearth & Home Technologies recommends to use a heavy duty vacuum cleaners specifically designed for solid fuel appliance cleaning.

8. Soot and Fly Ash: Formation & Need for Removal in Exhaust Venting System.

- **Frequency:** Yearly or more frequently depending on ash build-up.
- **By:** Qualified Service Technician/Homeowner

Be sure the appliance is allowed to cool, has been unplugged and the exhaust blower is off.

The products of combustion will contain small particles of fly ash. The fly ash will collect in the exhaust venting system and restrict the flow of the flue gases.

At start-up if there is incomplete combustion, or if there is a shutdown or incorrect operation of the appliance it will lead to some soot formation. This will collect in the exhaust venting system.

The venting (chimney) system may need to be cleaned at least once a year or more often depending upon the quality of your fuel or if there are any horizontal pipe sections. Ash will build up more quickly in the horizontal sections and elbows.

9. Door Handle Inspection

- **Frequency:** Monthly or prior to heating season
- **By:** Homeowner

The gasketing between the glass and firebox should be inspected periodically to make sure there is a good seal. Check door handle for smooth cam operation.

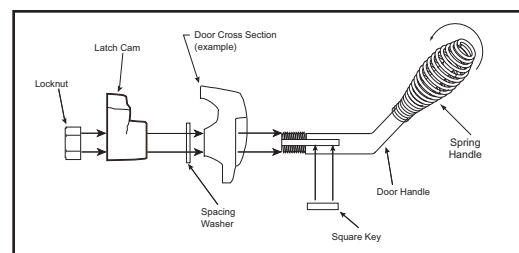
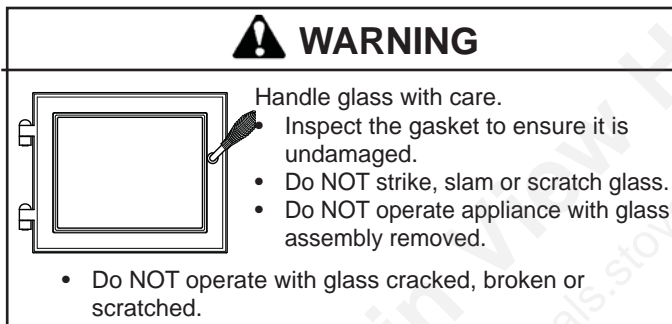
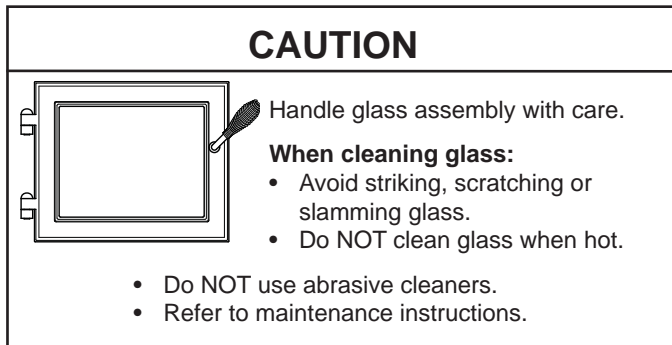

Figure 14.2

10. Cleaning the Glass

- **Frequency:** When clear view of the firepot becomes obscure
- **By:** Homeowner
 - a. Appliance must be completely cool before cleaning glass.
 - b. Vacuum fly ash from glass and door rope.
 - c. Use a damp paper towel or any non-abrasive glass cleaner. Wipe off with dry towel.



11. Cleaning Exhaust Blower - Requires No Lubrication

- **Frequency:** Yearly or more frequently depending on ash build-up
- **By:** Homeowner or Qualified Service Technician
 - a. Be sure the appliance is allowed to cool, has been unplugged and the exhaust blower is off.
 - b. Follow the directions for cleaning the exhaust path found on **page 14**.
 - c. If unable to thoroughly clean the blower through this access, then follow the directions on **page 19** for direct access to the exhaust blower.
 - d. Vacuum the blower's impellers. Use care not to bend or damage the blower fins.

NOTE: Hearth & Home Technologies recommends to use a heavy duty vacuum cleaners specifically designed for solid fuel appliance cleaning.

12. Cleaning Convection Blower - Requires No Lubrication

- **Frequency:** Yearly or more frequently depending on Dust/Dirt build-up
- **By:** Homeowner or Qualified Service Technician
 - a. Be sure the appliance is allowed to cool and has been unplugged.
 - b. Follow the directions on **page 18** for direct access to the convection blower.
 - c. Sweep or vacuum out any build-up. Use a brush or compressed air to loosen dirt if needed.

13. Cleaning the Top Vent Adapter

- **Frequency:** Yearly or more frequently depending on ash build-up
- **By:** Homeowner
 - a. The appliance must be in complete shutdown and the exhaust blower should be off. Allow the appliance to completely cool down.
 - b. Open the clean-out cover. **Figure 15.1**.
 - c. Sweep or vacuum out any ash build-up.

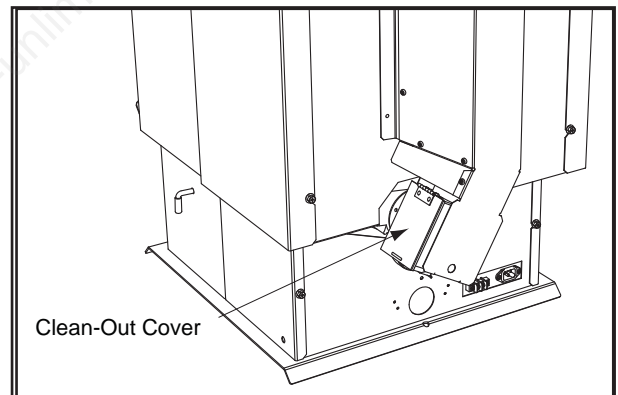

Figure 15.1

14. Preparing Firebox for Non-Burn Season

- **Frequency:** Yearly
- **By:** Homeowner
 - a. Be sure the appliance is allowed to cool, has been unplugged and the exhaust blower is off.
 - b. Remove all ash from the firebox and vacuum thoroughly.
 - c. Paint all exposed steel, including cast-iron.
 - Purchase paint from your local dealer.
 - Must use a high-temperature paint made specifically for heating appliances.

D. High Ash Fuel Content Maintenance

- **Frequency:** As needed
- **By:** Homeowner

Poor quality pellet fuel, or lack of maintenance, can create conditions that make the firepot fill quickly with ashes and clinkers.

This condition makes the appliance susceptible to overfilling the firepot with pellets which may result in smoking, sooting and possible hopper fires. **Figure 16.1** shows an example where the firepot overfills, pellets back up into the feed tube and ash has accumulated in the firebox.

An inefficient and non-economical method of burning of fuel caused by poor quality pellet fuel is shown in **Figure 16.2**.

The correct flame size when good quality, premium pellet fuel is burned is shown in **Figure 16.3**.

If the ash buildup exceeds the half way point in the firepot **IMMEDIATE ATTENTION AND CLEANING IS REQUIRED.**

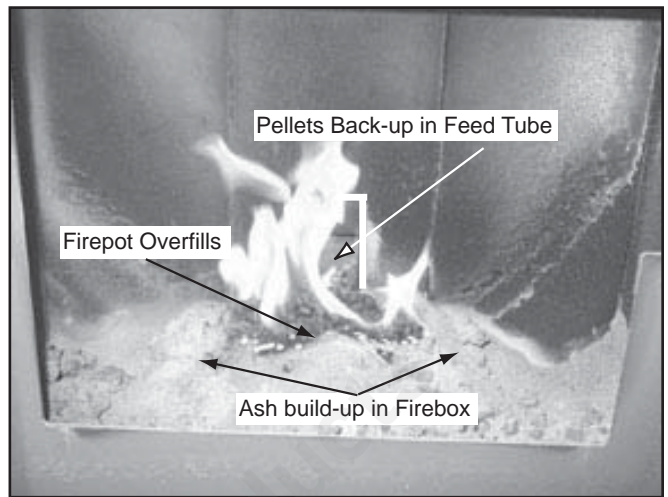

Figure 16.1

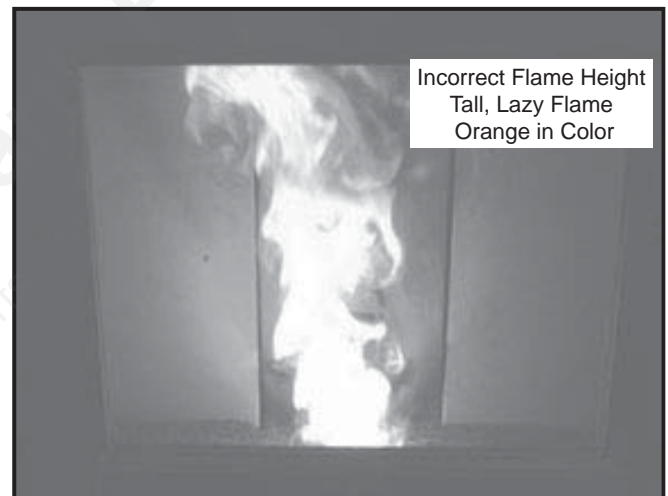

Figure 16.2

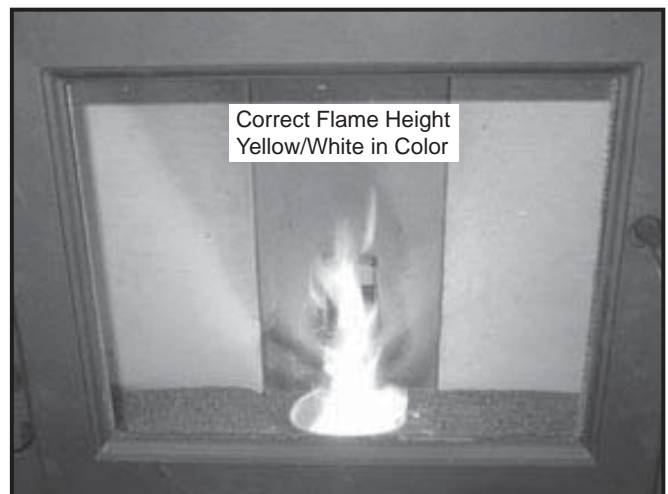



Figure 16.3

 WARNING	
	Fire Risk
	<ul style="list-style-type: none">• High ash fuels, or lack of maintenance, can cause the firepot to overfill. Follow proper shutdown procedure if ash buildup exceeds halfway point in firepot.• Failure to do could result in smoking, sooting and possible hopper fires.

CAUTION	
Odors and vapors released during initial operation.	
<ul style="list-style-type: none">• Curing of high temperature paint.• Open windows for air circulation.	
Odors may be irritating to sensitive individuals.	

E. Frequently Asked Questions

What causes my glass to become dirty?

If the glass has white ash build up it is normal and the glass should be cleaned. If it is a black soot build up air-flow thru the unit may be restricted. The most often cause is overdue maintenance and cleaning. See "Maintaining and Servicing Appliance" in the owner's manual.

How can I get more heat out of the appliance?

The most often cause of diminished heat output is overdue maintenance and cleaning. See "Maintaining and Servicing Appliance" in the owner's manual. If this still does not help, verify the correct settings for maximum heat output. See "Feed Rate Adjustment" under "Operating Instructions" in the owner's manual.

What should I do if I smell smoke or there is ash/soot coming from the appliance?

While there will always be some smoke smell from wood burning appliances (including pellet) you should investigate all venting to make sure it is sealed properly. Most venting requires silicone to seal the seams. In addition most homes are built very tight today and with exhaust systems can create negative pressure in the home. See "Negative Pressure" under "Getting Started" in the owner's manual if you have checked the venting but still have smoke coming from the appliance. For ash or soot check the above and the exhaust blower housing and seals.

Why would my appliance run fine last winter but not start this fall?

It is possible that the stove was not properly prepared for the Non-burn season. See "Trouble shooting" in the owner's manual.

Why would the metal on the inside of the appliance begin to flake?

There are some pellet mills that get their raw materials from lumber mills that purchase logs that are transported in sea water. These pellets can have a higher salt content and cause the metals in the unit to corrode prematurely and deteriorate. If you are seeing any components inside the firebox deteriorate it is recommended to change pellet brands immediately.

Why does only the exhaust blower run when I unplug and plug back in my appliance?

This is a Safety feature to prevent the unit from operating in an unsafe condition. Allow the unit to run and it will return to normal operation.

Is there a place to lubricate the blowers to quiet them down?

The most often cause of noisy blowers is from the impellers becoming dirty over time. See "General Maintenance & Cleaning" under "Maintaining & Servicing Appliance" in the owner's manual. No form of lubrication should ever need applied to the blowers.

Why are different components cycling on and off in my appliance at random?

The selector switch on control box may be on the wrong

setting. Refer to the Reference Materials section of our owner's manual for details.

What is the metal object with the bend in it for that came inside the plastic bag?

It is a clean-out tool used to help clean the firepot and remove any jams in the rare event they occur in the feed tube.

Why is there a black residue building up on the outside of my home?

Wind can cause this to happen. If the appliance is operating correctly very little soot should ever exit the termination cap. Also check to be sure the venting is installed per the owner's manual and local codes.

Do I need an outside air kit?

Outside air is required for mobile home installs and in some jurisdictions. Refer to "Listing & Code Approvals", "Mobile Home Installation" and "Appliance Set-up" owner's manual. Also refer to local building codes.

I am seeing sparks coming out of my pipe (termination cap) outside is this safe?

This is normal. As long as clearances to combustibles were followed this is safe.

My unit sounds like a freight train at times what can be done to eliminate this?

This is referred to as Rumbling. Maintenance may be needed see "Maintaining and Servicing appliance" in the owner's manual. Decrease fuel flow see "Feed rate adjustment" under Operating Instructions".

Why does my unit run fine on high, but shuts down on low and medium?

Maintenance may be needed see "Maintaining and Servicing Appliance" See also "Trouble Shooting".

Can I use another brand of wall thermostat or remote system?

Yes, any remote/wall thermostat system that does not require power from the appliance should work.

I have no power to anything. Does this unit have a circuit breaker or fuse or a reset button?

This unit has one serviceable fuse in the junction box and a reset button for the thermostat circuit.

Can I burn corn in my unit?

Corn is not an approved fuel for the ECO units.

I'm thinking about going green (solar power) and need to know what the power consumption is on my Unit.

PS50 115 VAC, 60 Hz, Start 5.1 Amps, Run 3.0 Amps.
PS35 115 VAC, 60 Hz, Start 3.8 Amps, Run 1.3 Amps.

Where is the serial # of my unit is located?

The serial # is located on the back of the stove.

4 Replacement Parts

A. Convection Blower Replacement

1. Turn down the thermostat, let appliance completely cool and then unplug appliance before servicing.
2. The convection blower is located on the floor at the rear of the appliance.
3. Lift the hopper lid up until it locks into place.
4. Loosen the 4 screws on the upper back panel and the 2 screws on the lower back panel, using a #2 Phillip Head screwdriver, a 3/8 inch wrench or a 3/8 Inch socket. You do not need to remove them.

Figure 18.1.

5. Remove the left upper and lower side panels by lifting up and out. The hooks on the panels will slide out of the slots on the appliance. **Figure 18.2.**
6. Release blower wires from the nylon wire retainer if applicable. Model ECO-ADV-PS35 has 2 black wires and Model ECO-ADV-PS50 and ECO-CAB50 has 1 black and 1 white wire coming from the blower.
7. Remove the wing bolt and move the blower and hold-down bracket toward the back of the appliance to release the locating tab. **Figure 18.3.** Pull the blower out from under the convection plenum. Slide the blower out of the appliance. Disconnect the wires from the spade connectors at this time. **Figure 18.4.**
8. Return wires to nylon wire retainer. Make sure wires do not contact any moving parts or touch any surfaces that may become hot **Figure 18.4.**

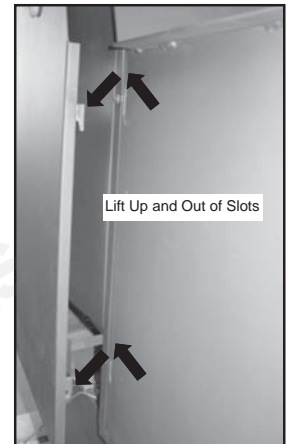
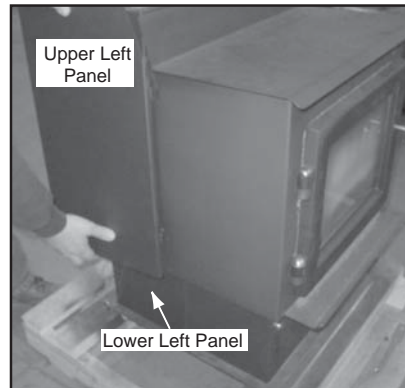

Figure 18.2

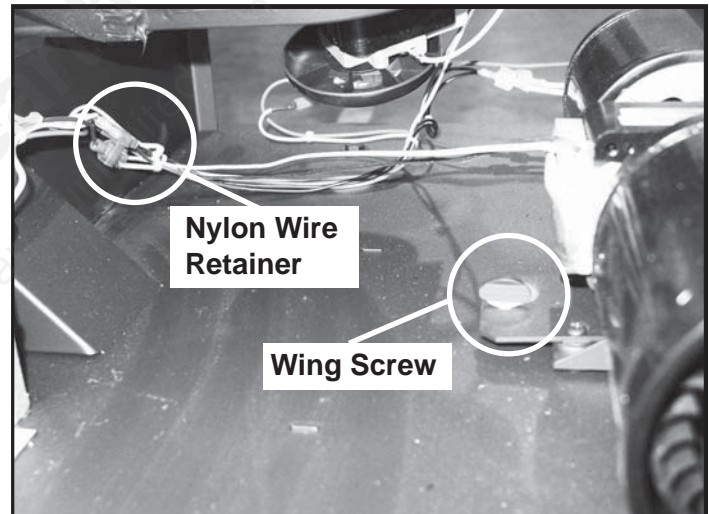

Figure 18.3

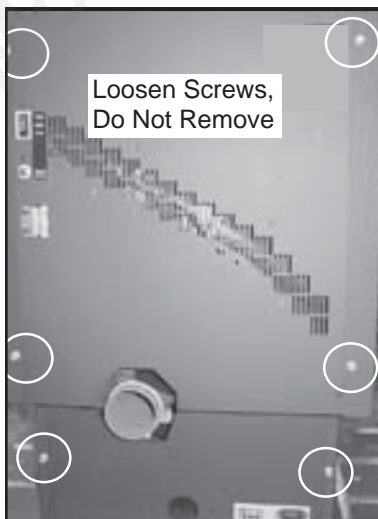

Figure 18.1

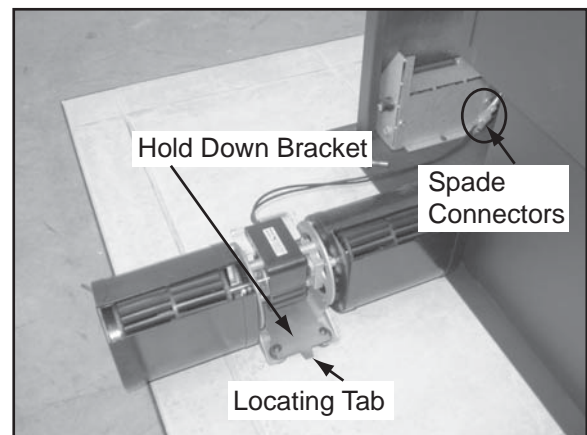

Figure 18.4

B. Exhaust Blower Replacement

1. Turn down the thermostat, let appliance completely cool and then unplug appliance before servicing.
2. Remove both upper and lower right side curtains. **Figure 18.2. on page 18.**
3. Disconnect 2 white wires from the white and blue wires of the exhaust blower.
4. There is a removable plate on the exhaust blower. Depending on the model, use a 1/4 inch socket, or 1/4 inch Nut Driver or #2 Phillips Head screw driver to loosen the 6 screws in the keyhole shaped holes and rotate the plate. It is only necessary to loosen screws. **Figure 19.1.**
5. Remove the exhaust blower and gasket.
6. Check for degradation on the gasket and replace if necessary using the gasket included in the kit.
7. Re-install in reverse order.

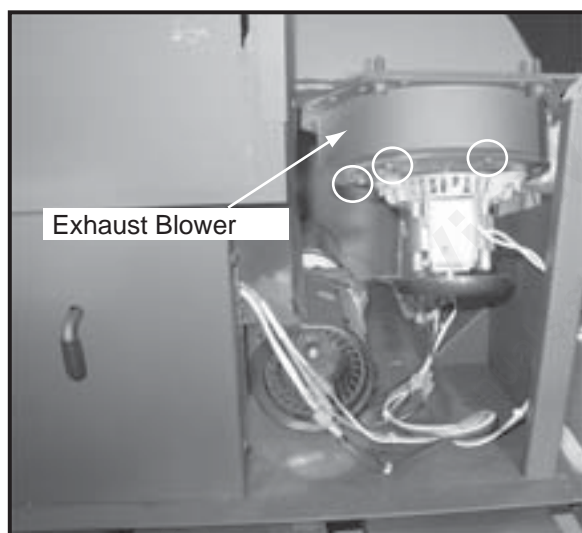

Figure 19.1

C. Snap Disc Replacements

Snap Disc #1 - Convection Blower

1. Turn down thermostat, let appliance cool completely if running. Then unplug appliance before servicing.
2. Using #2 Phillips screwdriver, 3/8" wrench, or 3/8" socket loosen the three screws that hold the right upper and lower side panels in place. You do not need to remove the screws. Remove side panels by lifting up and out.
3. Snap disc #1 is located on the convection plenum below the feed motor. **Figure 20.1.**
4. It has two purple wires attached to it with 1/4 inch female spade terminals.
5. Disconnect the two wires from the snap disc. Using a #2 Phillips screwdriver, remove the two screws securing the snap disc to the appliance.
6. Re-install in reverse.

Snap Disc #2 - Fuel Delivery Interrupt

1. Turn down thermostat, let appliance cool completely if running. Then unplug appliance before servicing.
2. Using #2 Phillips screwdriver, 3/8" wrench, or 3/8" socket loosen the three screws that hold the right upper and lower side panels in place. You do not need to remove the screws. Remove side panels by lifting up and out.
3. Snap disc #2 is located on the convection plenum in the center of the appliance above the convection blower. **Figure 20.1.**
4. It has a black wire and an orange wire attached to it with 1/4 inch female spade terminals.
5. Disconnect the two wires from the snap disc. Using a #2 Phillips screwdriver, remove the two screws securing the snap disc to the appliance.
6. Re-install in reverse.

Snap Disc #3 - Feed Motor - Manual Reset

1. Turn down thermostat, let appliance cool completely if running. Then unplug appliance before servicing.
2. Using #2 Phillips screwdriver, 3/8" wrench, or 3/8" socket loosen the three screws that hold the right upper and lower side panels in place. You do not need to remove the screws. Remove side panels by lifting up and out.
3. Snap disc #3 is located on the bracket on the feed tube near the feed motor. **Figure 20.1.**
4. It has a two gray wires attached to it with 1/4 inch female spade terminals.
5. The locating bracket is attached to the feed tube with an 8 X 32 wing nut. Remove the wing nut to detach the bracket from the feed tube.
5. Disconnect the two wires from the snap disc.
6. Using a #2 Philips screwdriver, remove the screw securing the snap disc to the bracket. **Figure 20.2.**
7. Re-install in reverse.

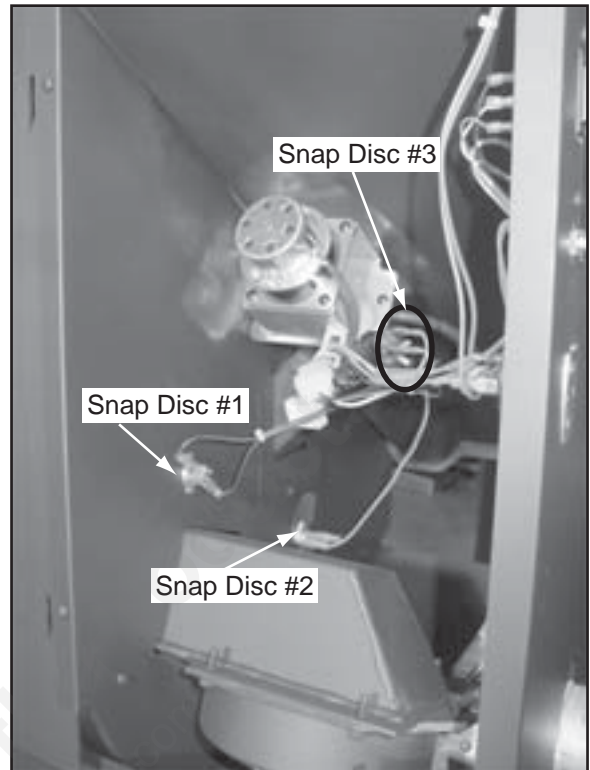

Figure 20.1

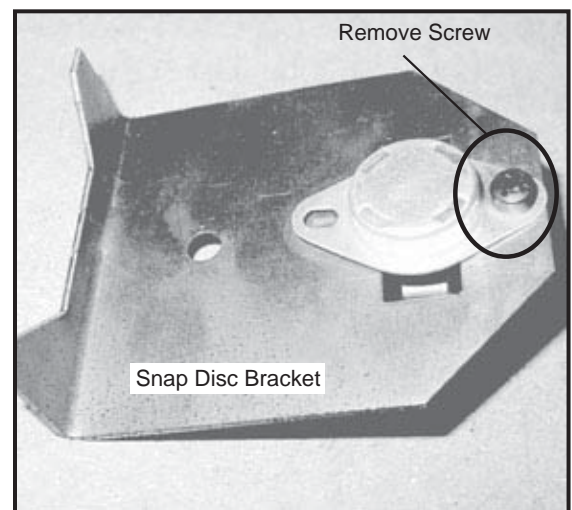

Figure 20.2

D. Igniter Replacement

1. Shut down the appliance by turning down the thermostat and let the appliance completely cool down. After the appliance has cooled down, unplug it and remove the ash drawer.

2. The wire leads to the igniter are connected to the wire harness with 1/4 inch male / female spade connectors.

Follow the directions on **page 18** to remove the upper and lower right side panels to expose the spade connectors.

Disconnect the spade connectors and remove the igniter from the chamber. Loosen thumb screw and slide igniter out.

3. Install new igniter into the chamber and tighten thumb screw. The wires **MUST** route through the wire retainer hook and then re-connect the wires to the 2 leads with the spade connectors. **Figure 21.1.**

4. Double check that the igniter wires are clear of any movement, i.e. ash drawer, firepot cleaning rod, , etc.

5. Re-install the ash drawer and side panel and re-connect the power.

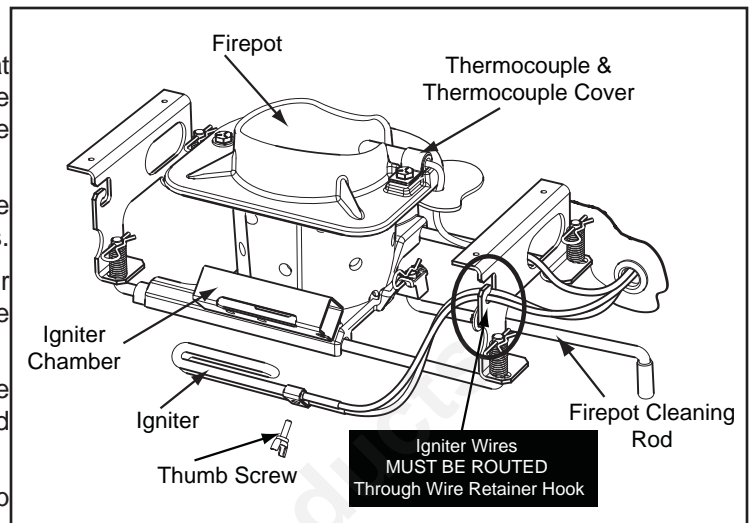



Figure 21.1

⚠ WARNING

Shock Risk.

- Igniter Wires **MUST** route through wire retainer hook.
- Failure to do so may result in:
- Pre-mature failure of igniter
- Shorted out igniter
- Appliance failing to light
- Damaged control box



E. Baffle Removal & Replace

1. Shut down the appliance by turning down the thermostat and let the appliance completely cool down.

2. Remove the center baffle first by using the handle at the top of the baffle and pull up and then towards you. The hooks on the baffle will slide out of the slots in the bracket. **Figure 21.2**

3. Remove the left baffle and then the right baffle by pulling up and then towards you. The left and right baffles have similar hooks and slots. **Figures 21.3 and 21.4.**

4. Re-install the baffles in reverse order. Be careful to insert the hooks in their respective slots. Be sure the baffles are completely secure/seated (close, if not touching, the fire-box floor).



Figure 21.2

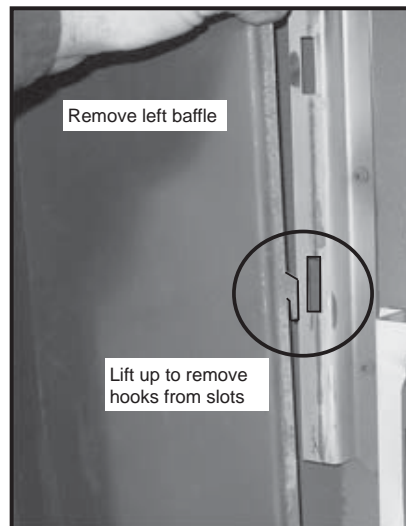

Figure 21.3

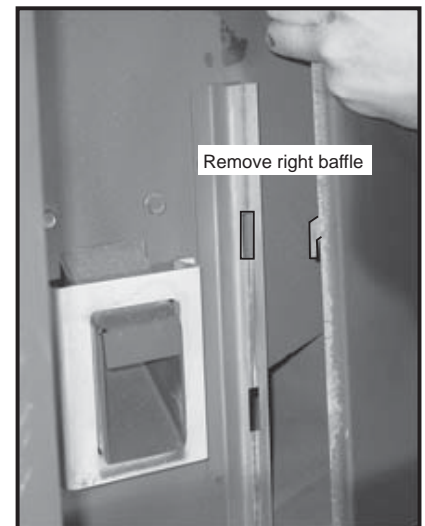

Figure 21.4

F. Glass Replacement

WARNING



- Glass is 5mm thick high temperature heat-resistant ceramic glass.
- DO NOT REPLACE with any other material.
- Alternate material may shatter and cause injury.

1. Open the door from the appliance by lifting door off of hinge pins and lay on a flat surface face down.
2. Using a Phillips Head screw driver, remove the 4 brackets and set aside. **Figure 22.1.**
3. Remove old glass and replace with the new glass.
4. Re-install the brackets using the same screws.

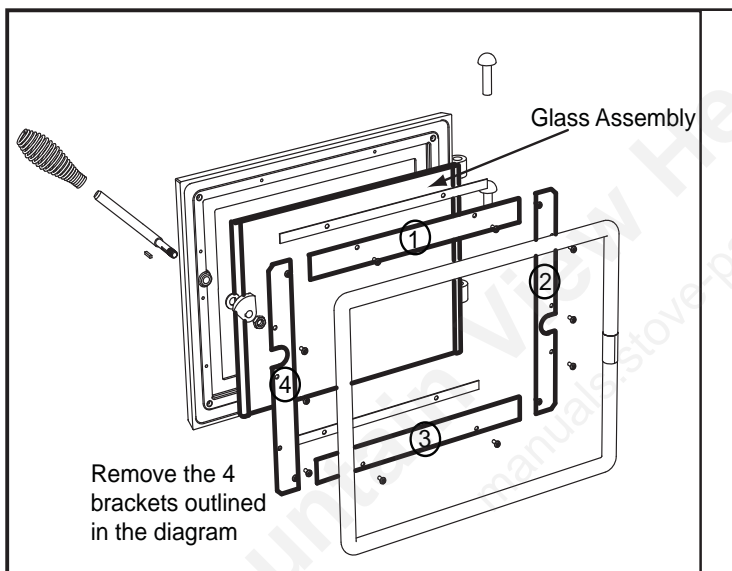

Figure 22.1

Installer's Guide

5 Getting Started

A. Design, Installation & Location Considerations B. Draft (Cont'd)

NOTICE: Check building codes prior to installation.

- Installation MUST comply with local, regional, state and national codes and regulations.
- Consult insurance carrier, local building inspector, fire officials or authorities having jurisdiction over restrictions, installation inspection and permits.

Since pellet exhaust can contain ash, soot or sparks, you must consider the location of:

- Windows
- Air Intakes
- Air Conditioner
- Overhang, soffits, porch roofs, adjacent walls
- Landscaping, vegetation

When locating vent and venting termination, vent above roof line when possible.

Warning! Risk of Fire Damaged parts could impair safe operation. Do NOT install damaged, incomplete or substitute components.

NOTICE: Locating the appliance in a location of considerable air movement can cause intermittent smoke spillage from appliance. Do not locate appliance near:

- Frequently open doors
- Central heat outlets or returns

B. Draft

Draft is the pressure difference needed to vent appliances successfully. When an appliance is drafting successfully, all combustion by products are exiting the home through the chimney.

Considerations for successful draft include:

- Preventing negative pressure
- Location of appliance and chimney

To measure the draft or negative pressure on your appliance use a manahelic or a digital pressure gauge capable of reading 0 - .25 inches of water column (W.C.).

The appliance should be running on high for at least 15 minutes for the test.

With the stove running on high you should have a negative pressure equal to or greater than the number given in the chart. **Figure 23.1** If you have a lower reading than you find on the chart, your stove does not have adequate draft to burn the fuel properly.

MODEL	Minimum Vacuum Requirements
ECO-ADV-PS35	.065 inches W.C.
ECO-ADV-PS50	.075 inches W.C.
ECO-CAB50	.075 inches W.C.

Figure 23.1

Correct low draft or low vacuum problems by doing one of the following:

- Thoroughly clean the exhaust path and venting. See Maintenance Section **page 14**.
 - Inspect for worn or broken gaskets. Repair any gaskets suspected of leaking.
 - Refer to Section 5 starting on **page 23** for recommendations on locating your appliance and chimney and for causes of and minimizing negative pressure
- NOTICE:** Hearth & Home Technologies assumes no responsibility for the improper performance of the chimney system caused by:
- Inadequate draft due to environmental conditions
 - Downdrafts
 - Tight sealing construction of the structure
 - Mechanical exhausting devices

C. Negative Pressure

WARNING! Risk of Asphyxiation! Negative pressure can cause spillage of combustion fumes and soot.

Negative pressure results from the imbalance of air available for the appliance to operate properly. It can be strongest in lower levels of the house.

Causes include:

- Exhaust fans (kitchen, bath, etc.)
- Range hoods
- Combustion air requirements for furnaces, water heaters and other combustion appliances
- Clothes dryers
- Location of return-air vents to furnace or air conditioning
- Imbalances of the HVAC air handling system
- Upper level air leaks such as:
 - Recessed lighting
 - Attic hatch

C. Negative Pressure (Cont'd)

- Duct leaks

To minimize the effects of negative air pressure:

- Install the outside air kit with the intake facing prevailing winds during the heating season
- Ensure adequate outdoor air for all combustion appliances and exhaust equipment
- Ensure furnace and air conditioning return vents are not located in the immediate vicinity of the appliance
- Avoid installing the appliance near doors, walkways or small isolated spaces
- Recessed lighting should be a “sealed can” design
- Attic hatches weather stripped or sealed
- Attic mounted duct work and air handler joints and seams taped or sealed

E. Locating Your Appliance & Chimney

Location of the appliance and chimney will affect performance.

- Install through the warm airspace enclosed by the building envelope. This helps to produce more draft, especially during lighting and die-down of the fire.
- Penetrate the highest part of the roof. This minimizes the affects of wind loading.

D. Thermostat Location

The thermostat’s location will have some affect on the appliance’s operation.

When the thermostat is located close to the appliance, it may require a slightly higher temperature setting to keep the rest of the house comfortable.

If the thermostat location is in an adjacent room or on a different floor level, you will notice higher temperatures near the appliance.

- Locate termination cap away from trees, adjacent structures, uneven roof lines and other obstructions.
- Minimize the use of chimney offsets.
- Consider the appliance location relative to floor and ceiling and attic joists.
- Take into consideration the termination requirements on **Page 31**.

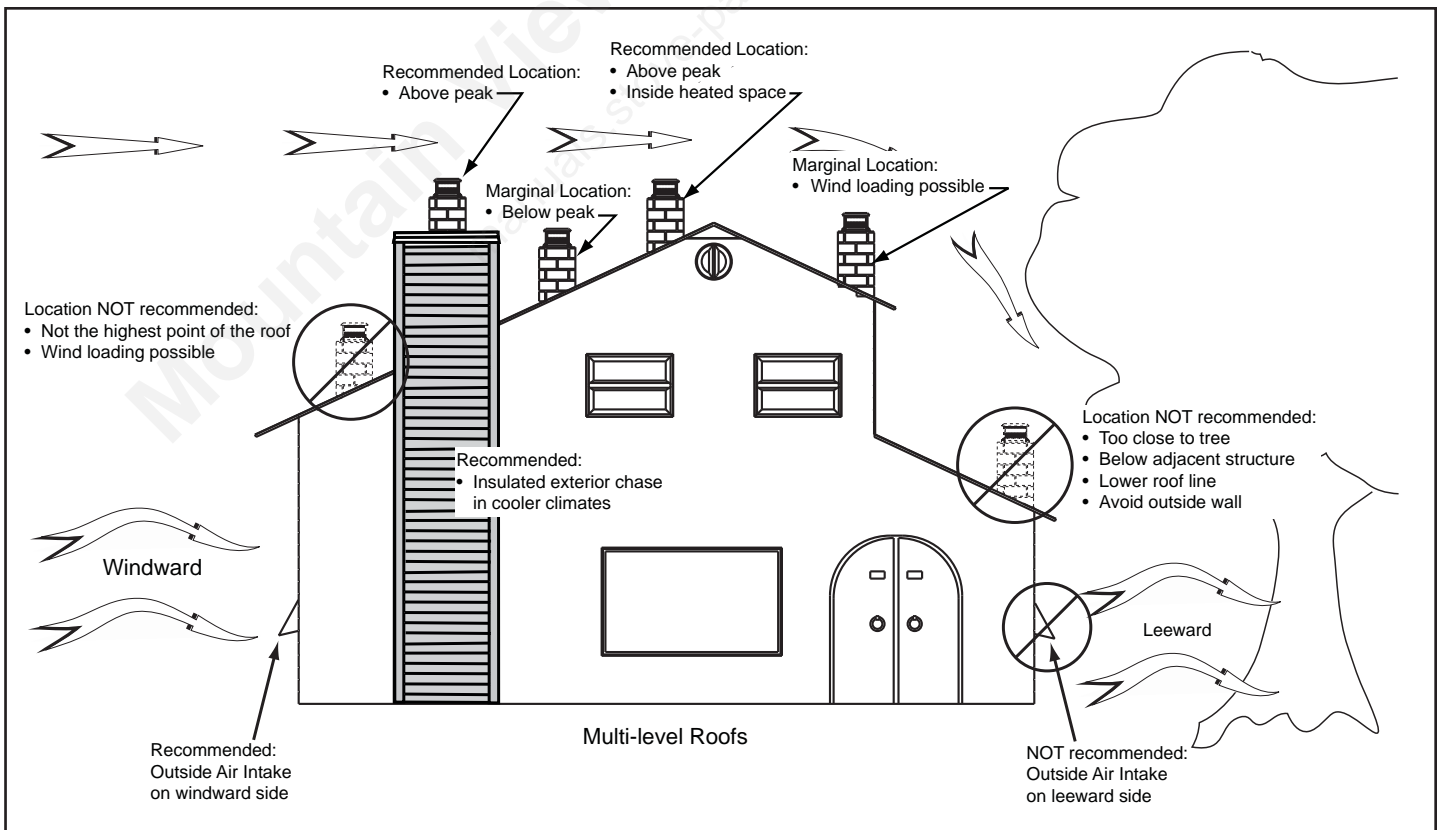

Figure 24.1

F. Tools And Supplies Needed

Tools and building supplies normally required for installation, unless installing into an existing masonry fireplace:

Reciprocating Saw	Gloves
Channel Locks	Safety Glasses
Hammer	Framing Square
Phillips Screwdriver	Electric Drill & Bits (1/4")
Tape Measure	1/4" Self-Tapping Screws
Plumb Line	
Level	<u>May also need:</u>
Framing Material	Vent Support Straps
Non-combustible Sealant Material	Venting Paint

WARNING



Fire Risk.

Hearth & Home Technologies disclaims any responsibility for, and the warranty will be voided by, the following actions:

- Installation and use of any damaged appliance.
- Modification of the appliance.
- Installation other than as instructed by Hearth & Home Technologies.
- Installation and/or use of any component part not approved by Hearth & Home Technologies.
- Operating appliance without fully assembling all components.
- Operating appliance without legs attached (if supplied with unit).
- Do NOT Overfire

Or any such action that may cause a fire hazard.

G. Inspect Appliance & Components

- Remove appliance and components from packaging and inspect for damage.
- Report to your dealer any parts damaged in shipment.
- **Read all the instructions before starting the installation. Follow these instructions carefully during the installation to ensure maximum safety and benefit.**

WARNING



Inspect appliance and components for damage. Damaged parts may impair safe operation.

- Do NOT install damaged components.
- Do NOT install incomplete components.
- Do NOT install substitute components.

Report damaged parts to dealer.

Pre-Burn Check List

1.		Place the appliance in a location near the final installation area and follow the procedures below:
2.		Open the appliance and remove all the parts and articles packed inside the Component Pack. Inspect all the parts and glass for shipping damage. Contact your dealer if any irregularities are noticed.
3.		All safety warnings have been read and followed.
4.		This Owner's Manual has been read.
5.		Floor protection requirements have been met.
6.		Venting is properly installed.
7.		The proper clearances from the appliance and chimney to combustible materials have been met.
8.		The masonry chimney is inspected by a professional and is clean, or the factory built metal chimney is installed according to the manufacturer's instructions and clearances.
9.		The chimney meets the required minimum height.
10.		All labels have been removed from the glass door.
11.		Plated surfaces have been wiped clean, if applicable.
12.		Thermostat or remote has been installed.
13.		A power outlet is available nearby.

6 Dimensions and Clearances

MODEL: ECO-ADV-PS35

A. Appliance Dimensions

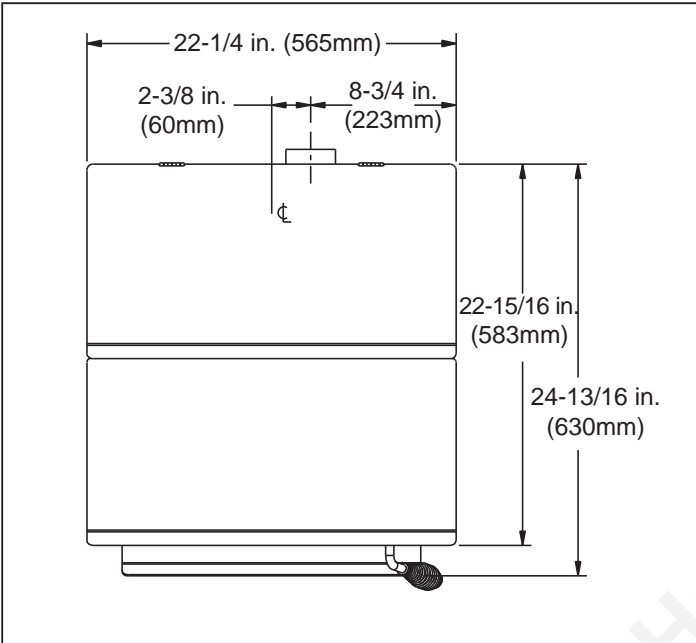

Figure 26.1 - Top View

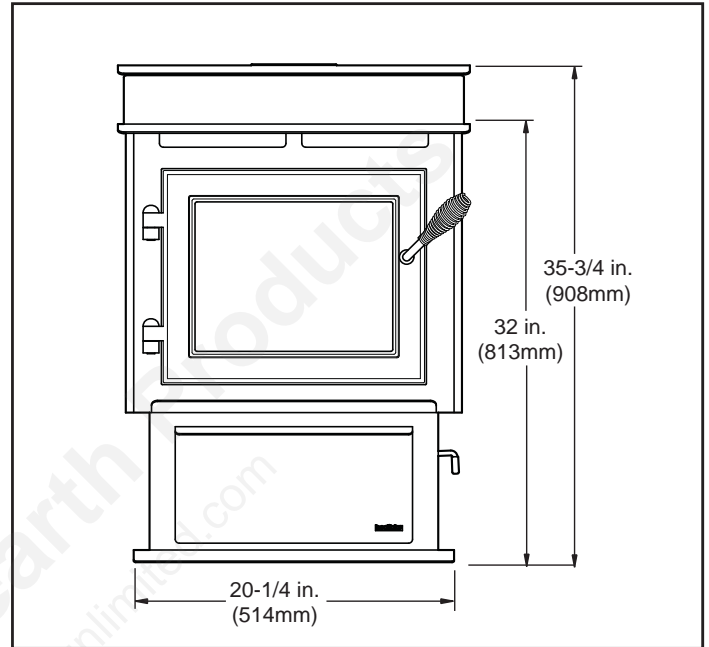

Figure 26.2- Front View

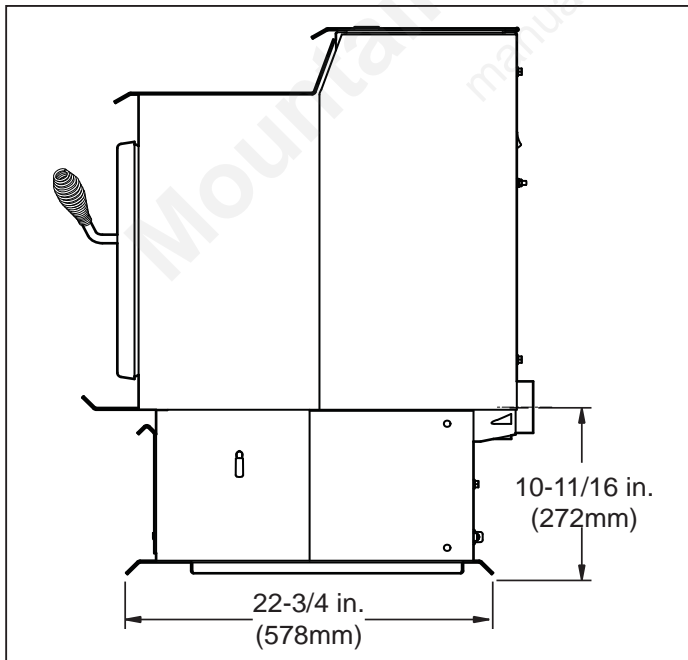

Figure 26.3 -Side View

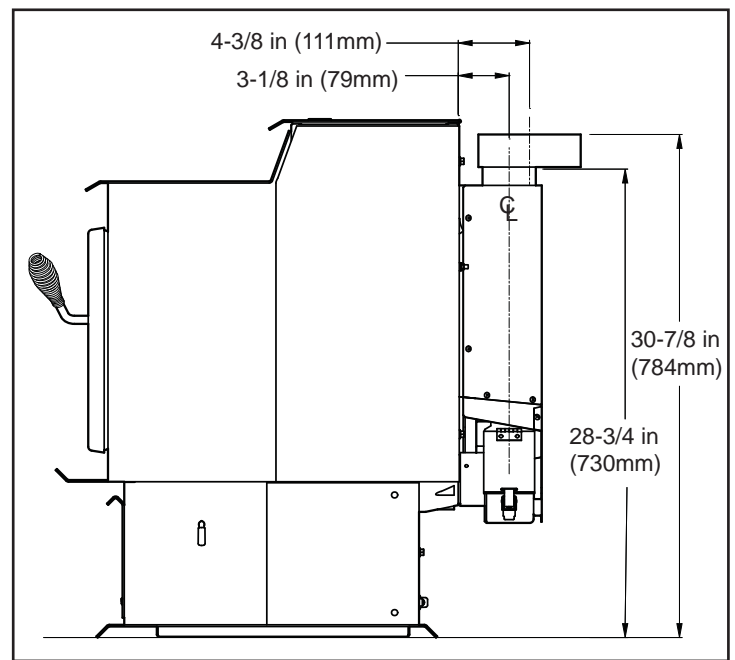

Figure 26.4 - Side View with Top Vent Adapter

MODEL: ECO-ADV-PS50

A. Appliance Dimensions (Cont'd)

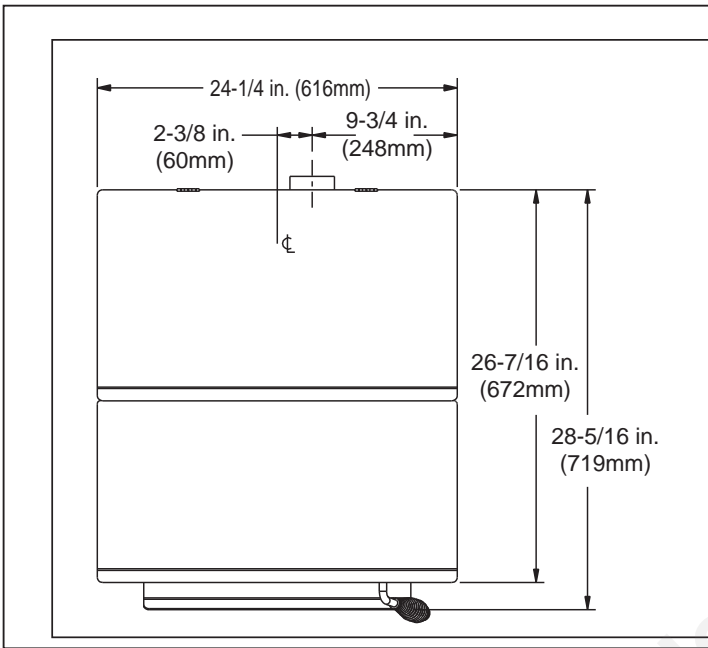

Figure 27.1 - Top View

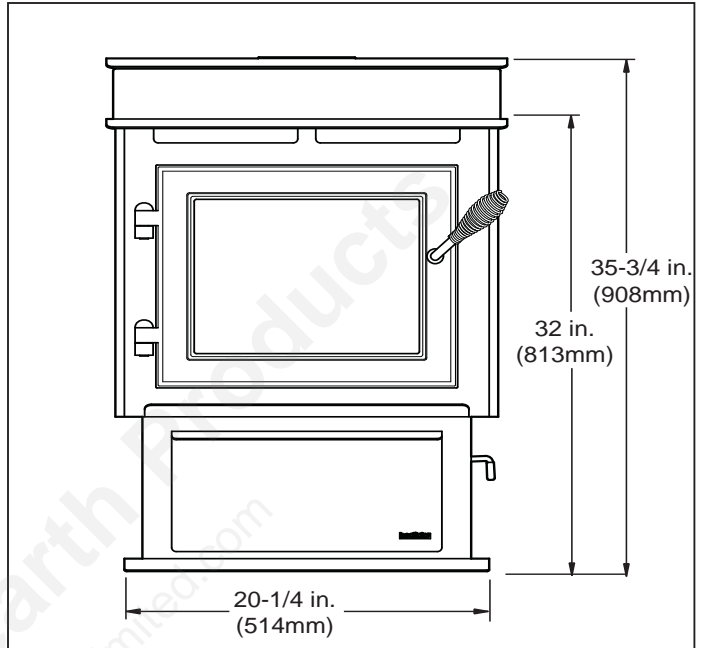

Figure 27.2- Front View

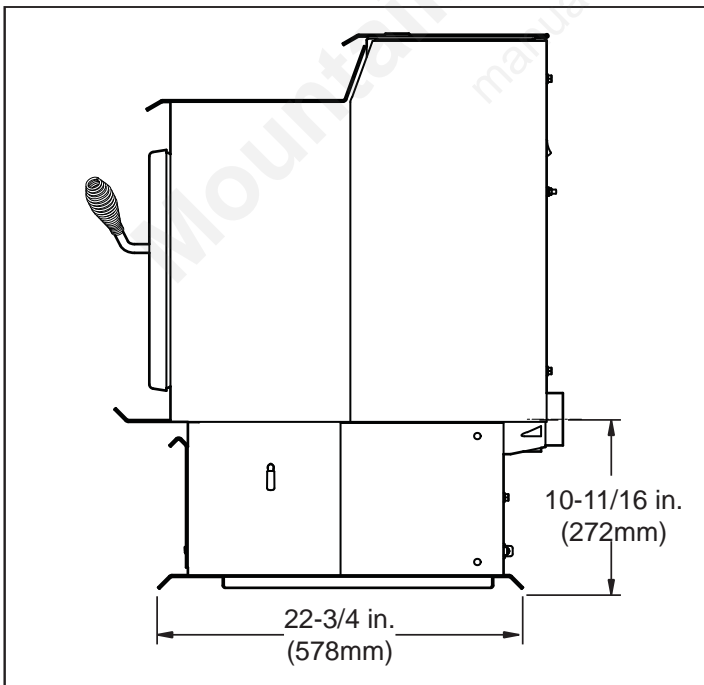

Figure 27.3 -Side View

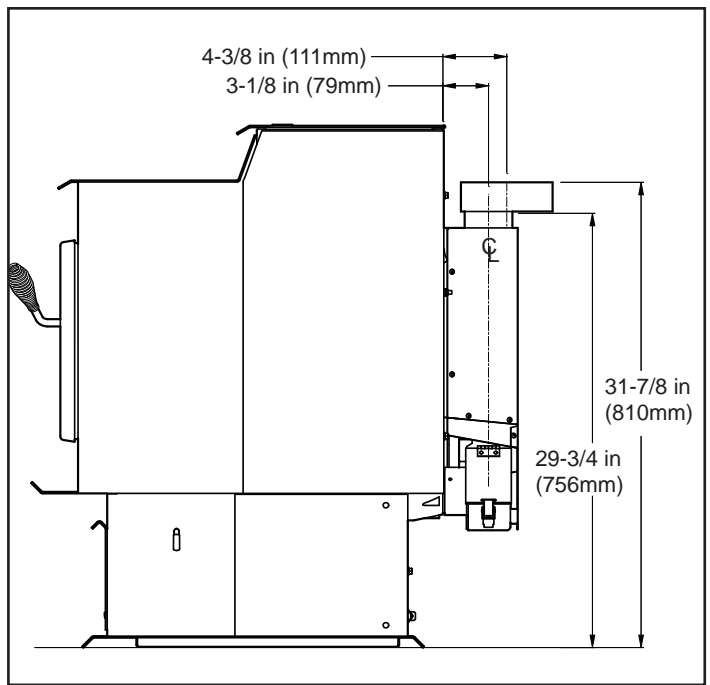

Figure 27.4 - Side View with Top Vent Adapter

MODEL: ECO-CAB50

A. Appliance Dimensions (Cont'd)

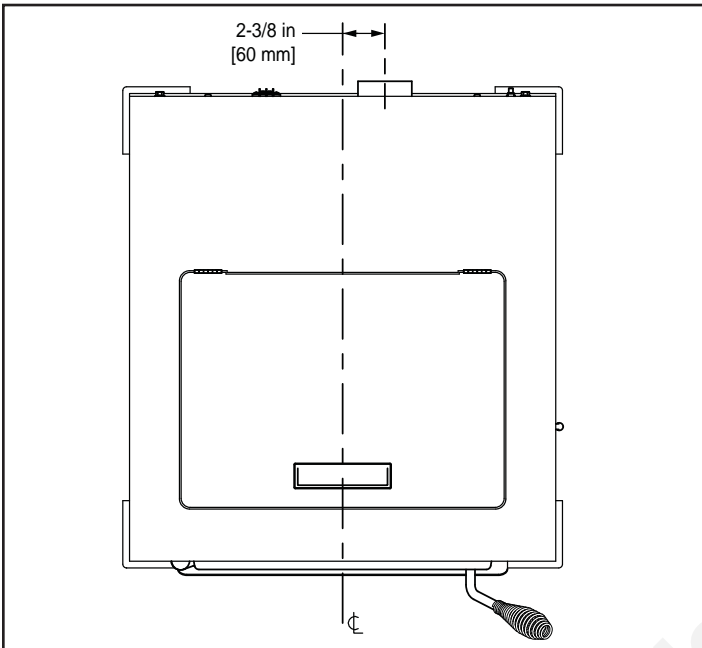

Figure 28.1 - Top View

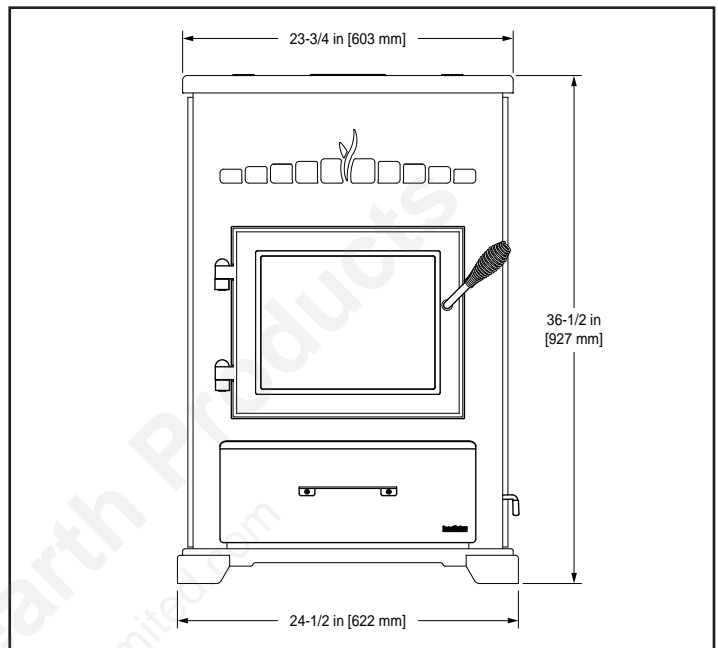

Figure 28.2- Front View

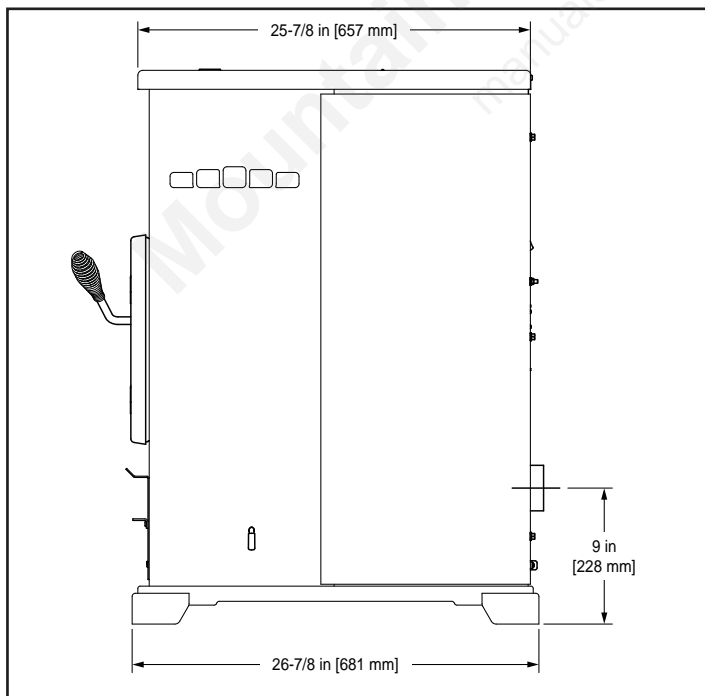

Figure 28.3 -Side View

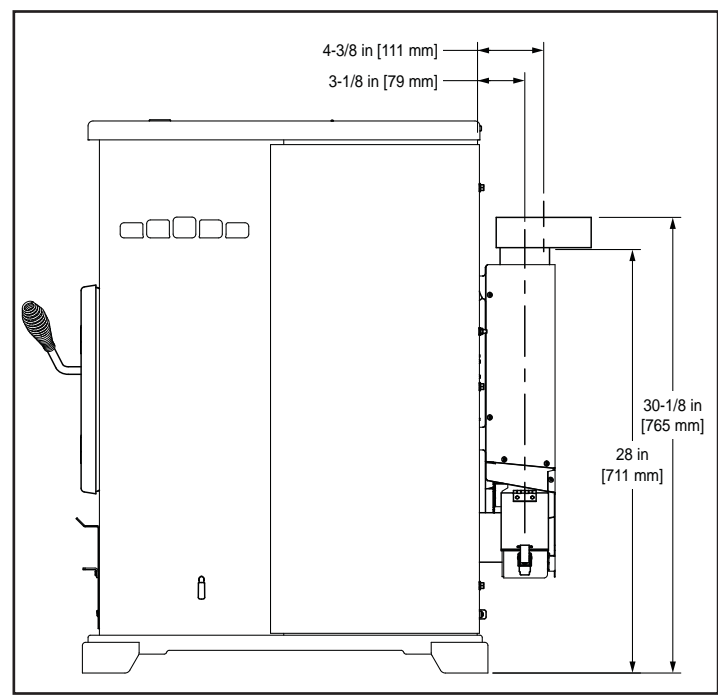
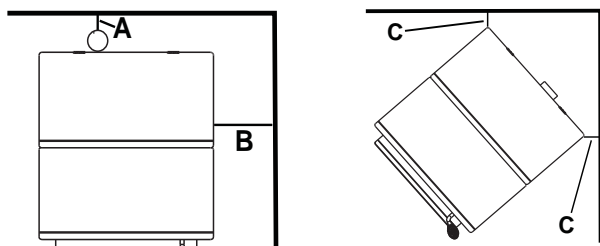

Figure 28.4 - Side View with Top Vent Adapter

B. Clearances to Combustibles (UL and ULC)



Straight Back Against Wall		Inches	Millimeters
A	Back Wall to Appliance	2	51
B	Side Wall to Appliance	14	356

Corner Installation		Inches	Millimeters
C	Walls to Appliance	2	51

Installations with 3 to 3 inch Top Vent Adapter

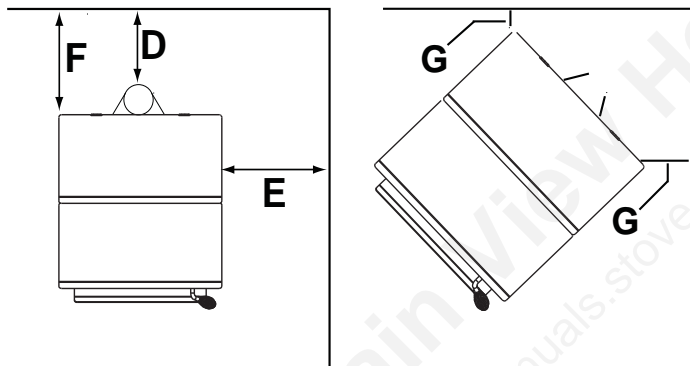

Vertical Installation		Inches	Millimeters
D	Back Wall to Adapter	1	25
E	Side Wall to Appliance	14	356
F	Back Wall to Appliance	6-1/4	159

Corner Installation		Inches	Millimeters
G	Walls to Appliance	2	51

Installations with 3 to 6 inch Offset Adapter

Vertical Installation		Inches	Millimeters
D	Back Wall to Adapter	3	76
E	Side Wall to Appliance	14	356
F	Back Wall to Appliance	10-3/4	274

Corner Installation		Inches	Millimeters
G	Walls to Appliance	2	51

Installations Into Alcove

All minimums listed are to a combustible surface.

Model: PS35	Minimum		Maximum	
	Inches	Millimeters	Inches	Millimeters
Height	51-3/4	1314	n/a	n/a
Width	50-1/4	1276	n/a	n/a
Depth	n/a	n/a	48	1219
Side Wall	14	356	n/a	n/a
Top	21	533	n/a	n/a
Mantle Depth	n/a	n/a	36	914

Model: PS50	Minimum		Maximum	
	Inches	Millimeters	Inches	Millimeters
Height	56-3/4	1441	n/a	n/a
Width	53	1346	n/a	n/a
Depth	n/a	n/a	48	1219
Side Wall	14	356	n/a	n/a
Top	21	533	n/a	n/a
Mantle Depth	n/a	n/a	36	914

Model: CAB50	Minimum		Maximum	
	Inches	Millimeters	Inches	Millimeters
Height	56-3/4	1441	n/a	n/a
Width	53	1346	n/a	n/a
Depth	n/a	n/a	48	1219
Side Wall	14	356	n/a	n/a
Top	21	533	n/a	n/a
Mantle Depth	n/a	n/a	36	914

WARNING



Fire Risk.
Comply with all minimum clearances to combustibles as specified.
Failure to comply may cause house fire.

NOTE:

- Illustrations reflect typical installations and are FOR DESIGN PURPOSES ONLY.
- Illustrations/diagrams are not drawn to scale.
- Actual installation may vary due to individual design preference.

C. Alcove

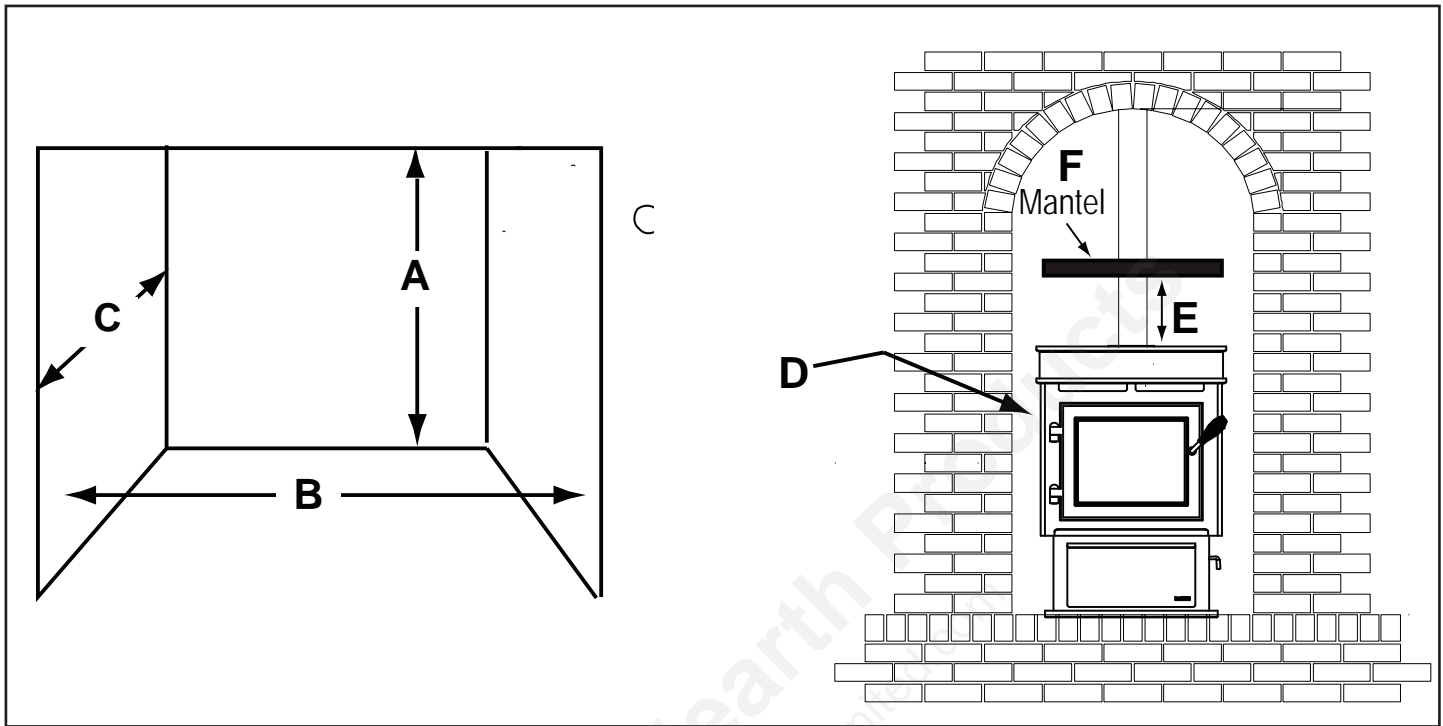

Figure 30.1

All minimums listed are to a combustible surface.

Model: PS35		Minimum		Maximum	
		Inches	Millimeters	Inches	Millimeters
A	Height	51-3/4	1314	n/a	n/a
B	Width	50-1/4	1276	n/a	n/a
C	Depth	n/a	n/a	48	1219
D	Side Wall	14	356	n/a	n/a
E	Top	16	533	n/a	n/a
F	Mantel Depth	n/a	n/a	36	914

Model: CAB50		Minimum		Maximum	
		Inches	Millimeters	Inches	Millimeters
A	Height	56-3/4	1441	n/a	n/a
B	Width	53	1346	n/a	n/a
C	Depth	n/a	n/a	48	1219
D	Side Wall	14	356	n/a	n/a
E	Top	16	533	n/a	n/a
F	Mantel Depth	n/a	n/a	36	914

Model: PS50		Minimum		Maximum	
		Inches	Millimeters	Inches	Millimeters
A	Height	56-3/4	1441	n/a	n/a
B	Width	53	1346	n/a	n/a
C	Depth	n/a	n/a	48	1219
D	Side Wall	14	356	n/a	n/a
E	Top	16	533	n/a	n/a
F	Mantel Depth	n/a	n/a	36	914

NOTE:

- Illustrations reflect typical installations and are FOR DESIGN PURPOSES ONLY.
- Illustrations/diagrams are not drawn to scale.
- Actual installation may vary due to individual design preference.

CAUTION

- DO NOT CONNECT THIS UNIT TO A CHIMNEY FLUE SERVICING ANOTHER APPLIANCE.
- DO NOT CONNECT TO ANY AIR DISTRIBUTION DUCT OR SYSTEM.

D. Hearth Pad Requirements (UL and ULC)

Use a non-combustible floor protector, extending beneath appliance and to the front, sides and rear as indicated. Measure front distance "M" from the surface of the glass door.

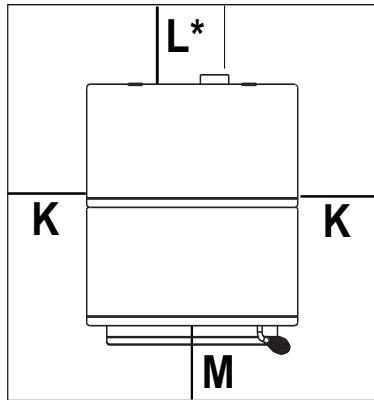

Figure 31.1

USA Hearth Pad Requirements

Hearth Pad Requirements		Inches
K	Sides	2
L*	Back	2
M	Front	6

Canada Hearth Pad Requirements

Hearth Pad Requirements		Millimeters
K	Sides	203
L*	Back	51
M	Front	152

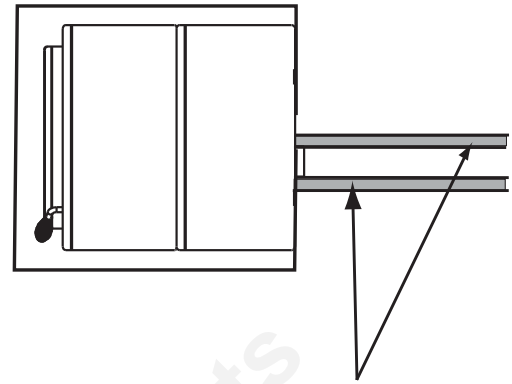

Must extend 2 inches (51mm) beyond each side of pipe (shaded area)

Figure 31.2

*L Exception for Horizontal Installations:

CANADA INSTALLATIONS: A non-combustible floor protection extending beneath the flue pipe is **required** with horizontal venting or under the top vent adapter with vertical installation. **Figure 31.2**

USA INSTALLATIONS: A non-combustible floor protection extending beneath the flue pipe is recommended with horizontal venting or under the top vent adapter with vertical installation. **Figure 31.2**



7 Vent Information

A. Chimney and Exhaust Connection

1. **Chimney & Connector:** Use 3 or 4 inch (76-102mm) diameter type "L" or "PL" venting system. It can be vented vertically or horizontally.
2. **Mobile Home:** Approved for all Listed pellet vent. If using the 3 inch (76mm) vertical Top Vent Adapter Kit or the 3 to 6 inch (76-152mm) Top Vent Offset Adapter, use Listed double wall flue connector. An authorized Outside Air Kit must be used with manufactured home installations.
3. **Residential:** The 3 inch (76mm) vertical Top Vent Adapter Kit and the 3 to 6 inch (76-152mm) Top Vent Offset Adapter are tested to use 24 gauge single wall flue connector or Listed double wall flue connector to Class A Listed metal chimneys, or masonry chimneys meeting International Conference of Building Officials (ICBO) standards for solid fuel appliances.
4. **INSTALL VENT AT CLEARANCES SPECIFIED BY THE VENT MANUFACTURER.**
5. Secure exhaust venting system to the appliance with at least 3 screws or rivets per the pipe manufacturer's instructions. Also secure all connector pipe joints with at least 3 screws through each joint.
6. **DO NOT INSTALL A FLUE DAMPER IN THE EXHAUST VENTING SYSTEM OF THIS UNIT.**
7. **DO NOT CONNECT THIS UNIT TO A CHIMNEY FLUE SERVING ANOTHER APPLIANCE.**

NOTE: All pipe must be welded seam pipe whenever possible. Seal pipe joints with high temperature silicone (500°F [260°C] minimum rated only). Do not put silicone inside of pipe.

 WARNING	
	Fire Risk. Follow Chimney Connector Manufacturer's Instructions for Proper Installation.
	ONLY use connector: <ul style="list-style-type: none">• Within the room, between appliance and ceiling or wall. Connector shall NOT pass through: <ul style="list-style-type: none">• Attic or roof space• Closet or similar concealed space• Floor or ceiling Maintain minimum clearances to combustibles

 WARNING	
	Vent surfaces get HOT, can cause burns if touched. Non-combustible shielding or guards may be required.

B. Venting Termination Requirements

CAUTION
Do not terminate vent in any enclosed or semi-enclosed area such as a carport, garage, attic, crawl space, under a sun deck or porch, narrow walkway or closely fenced area, or any location that can build up a concentration of fumes such as a stairwell, covered breezeway, etc.

1. Termination must exhaust above air inlet elevation. **It is strongly recommended that at least 60 inches (1.5m) of vertical pipe be installed when appliance is vented directly through a wall.** This will create a natural draft, which will help prevent the possibility of smoke or odor venting into the home during a power outage. It will also keep exhaust from causing a nuisance or hazard by exposing people or shrubs to high temperatures. The safest and preferred venting method is to extend the vent vertically through the roof.
2. Distance from doors and opening windows, or gravity or ventilation air inlets into building:
 - a. Not less than 48 inches (1.2m) below;
 - b. Not less than 48 inches (1.2m) horizontally from;
 - c. Not less than 12 inches (305mm) above.
3. Distance from permanently closed windows;
 - a. Not less than 12 inches (305mm) below; horizontally from or above.
4. Distance between bottom of termination and grade should be 12 inches (305mm) minimum. This is conditional upon plants in the area, and nature of grade surface. The grade surface must be a non-combustible material (i.e., rock, dirt). The grade surface must not be lawn. Distance between bottom of termination and public walkway should be 7 feet (2.13m) minimum.
5. Distance to combustible materials must be 24 inches (610mm) minimum. This includes adjacent buildings, fences, protruding parts of the structure, roof overhang, plants and shrubs, etc.
6. Termination Cap Location (Home Electrical Service)
 - Side-to-side clearance is to be the same as minimum clearance to vinyl inside corners.
 - Clearance of a termination cap below electrical service shall be the same as minimum clearance to vinyl soffits.
 - Clearance of a termination cap above electrical service will be 12 inches (305mm) minimum.
 - Location of the vent termination must not obstruct or interfere with access to the electrical service.

C. Pellet Venting Charts

The maximum horizontal venting allowed with no vertical venting attached is 48 inches (1219mm) including one 90° elbow or two 45° elbows. This is our recommended horizontal venting installation. Addition of any horizontal venting beyond 48 inches (1219mm) requires a minimum 60 inches (1524mm) of additional vertical vent. Horizontal sections of vent pipe should have a 1/4 inch (6.35mm) rise per foot.

Hearth & Home Technologies recommends any installation requiring more than two 90° elbows, or more than 15 feet (4.5m) of venting to use 4 inch (102mm) vent.

WARNING



Fire Risk.

- Only LISTED venting components may be used.
- NO OTHER vent components may be used. Substitute or damaged vent components may impair safe operation.

45° elbow is equivalent to 3 feet of horizontal pipe
90° elbow is equivalent to 5 feet of horizontal pipe

ONE 90° ELBOW (fig. 33.1)		
Total Horizontal	Minimum Vertical	Vent Diameter
4	0	3
5	5	3
6	6	3
7	7	3
8	8	4
9	9	4
10	10	4
11	11	4
12	12	4
13	13	4
14	14	4
15	15	4
16	16	4
17	17	4
18	18	4
19	19	4

TWO 90° ELBOWS (fig. 33.2)		
Total Horizontal	Minimum Vertical	Vent Diameter
2	5	3
3	6	3
4	7	3
5	8	3
6	9	3
7	10	4
8	11	4
9	12	4
10	13	4
11	14	4
12	15	4
13	16	4
14	17	4
15	18	4

THREE 90° ELBOWS (fig. 33.3)		
Total Horizontal	Minimum Vertical	Vent Diameter
2	11	4
3	12	4
4	13	4
5	14	4
6	15	4
7	16	4
8	17	4
9	18	4
10	19	4

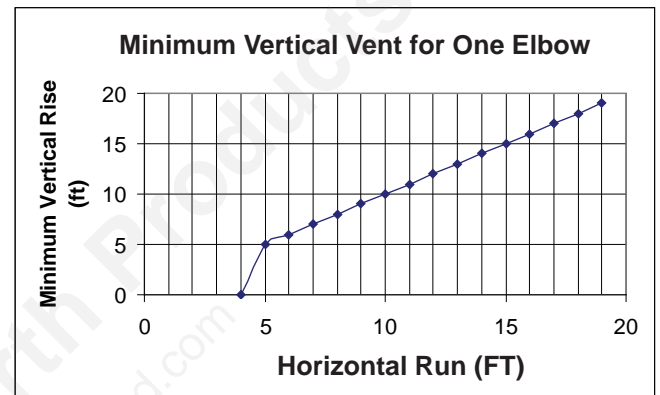

Figure 33.1

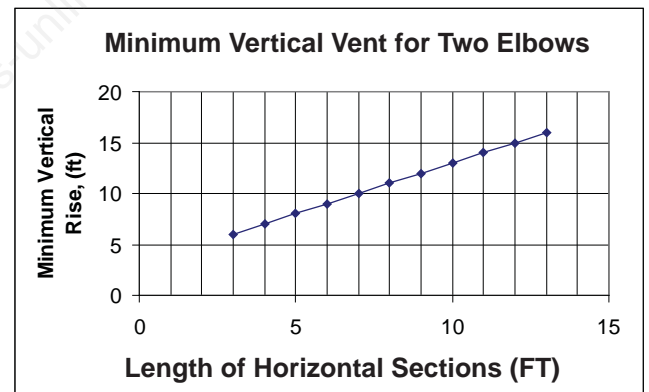

Figure 33.2

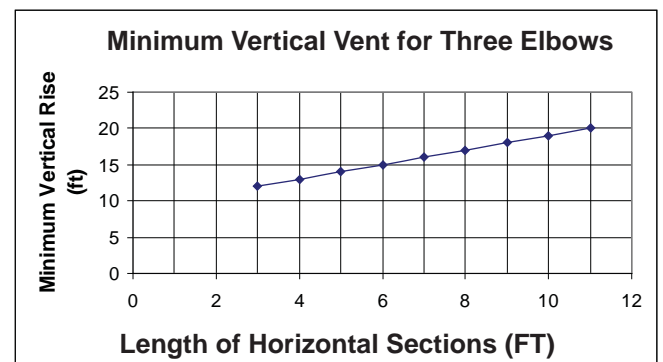

Figure 33.3

NOTICE: These are guidelines for successful venting of your pellet appliance. The more vertical rise you can obtain in your system, the better it will perform. Horizontal vent runs can accumulate ash and will need to be cleaned more often. Try to keep them as short as possible.

8 Venting Systems

A. Vertical - Interior - Typical Installation PREFERRED METHOD #1

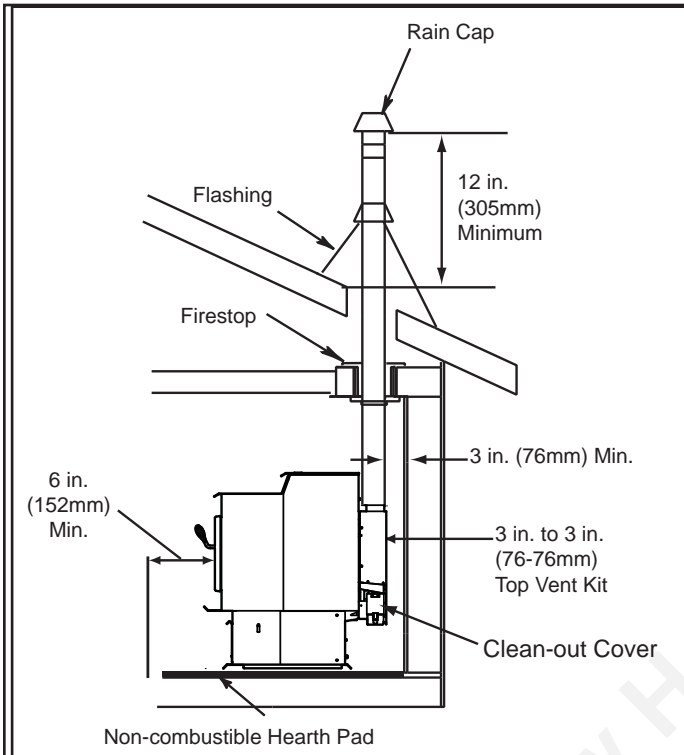

Figure 34.1

B. Through The Wall & Vertical - External PREFERRED METHOD #2

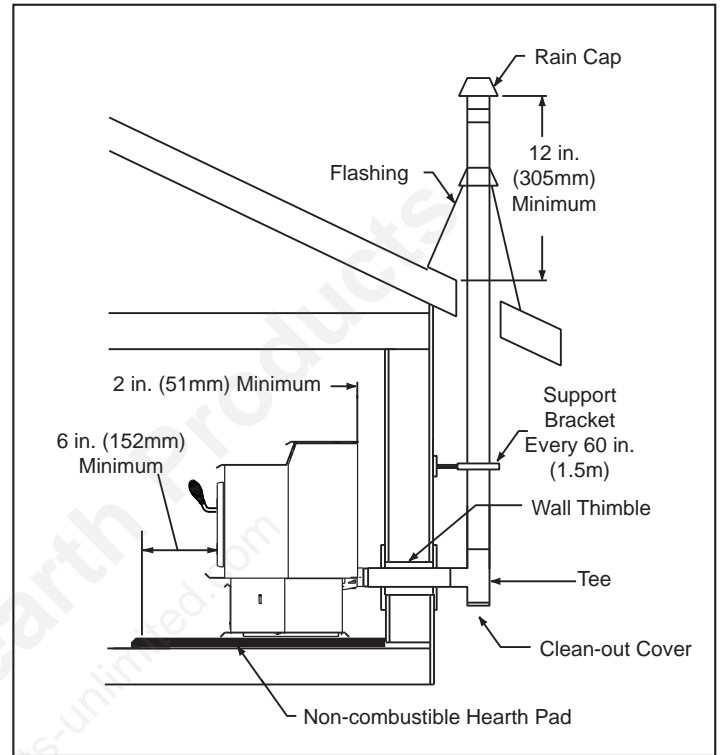

Figure 34.2

C. Vertical into Existing Class A Chimney

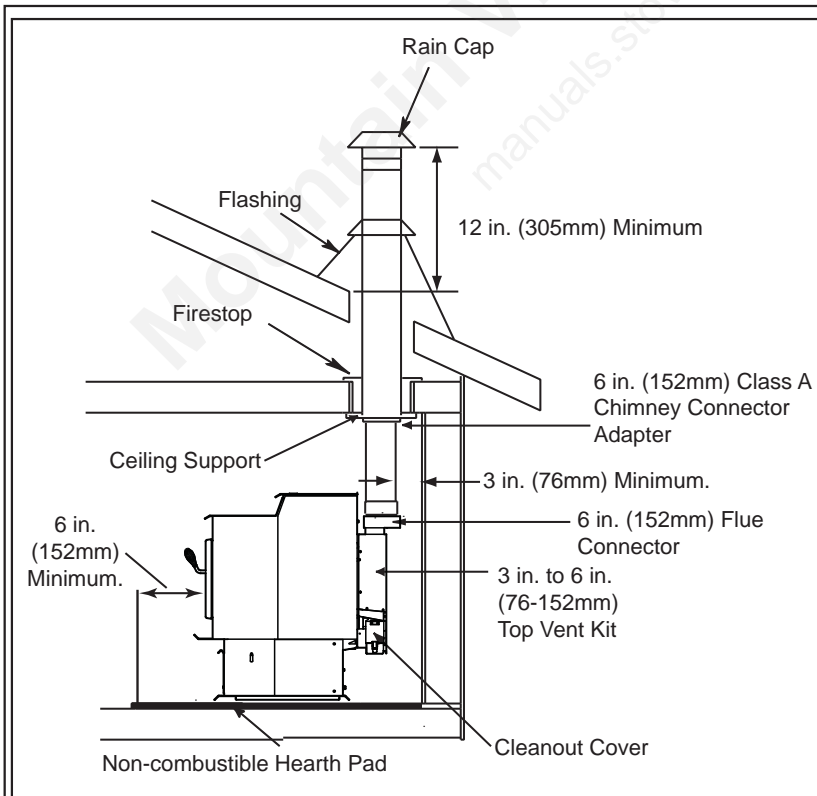

Figure 34.3

We strongly recommend a minimum of 60 inches (1.5m) vertical, however above the eave is preferred.

Both installations are approved for mobile home installations. Must use 3 or 4 inch (76 to 102mm) "L" or "PL" Listed pellet venting or Listed double wall pipe and authorized Outside Air Kit in mobile homes. Single wall pipe is approved for residential installations only.

Air Clearance to Pipe:

This appliance was tested with standard 3 inch (76mm) Listed pellet vent.

Pellet pipe manufactures Listed reduce clearance pipe may be use for reduce clearance from 3 inch (76mm) air clearance to no less than 1 inch (25mm) air clearance to combustibles for approved Listed pellet pipe.

Follow pipe manufactures listed air clearances to combustibles and installation instructions for all reduced air clearances installations.



WARNING

Fire Risk

Inspection of Chimney:



- Masonry chimney must be in good condition.
- Meets minimum standard of NFPA 211
- Factory-built chimney must be minimum 6 inch (152mm) UL103 HT.



WARNING

Improper installation, adjustment, alteration, service or maintenance can cause injury or property damage. Refer to the owner's information manual provided with this appliance. For assistance or additional information consult a qualified installer, service agency or your dealer.

D. Masonry

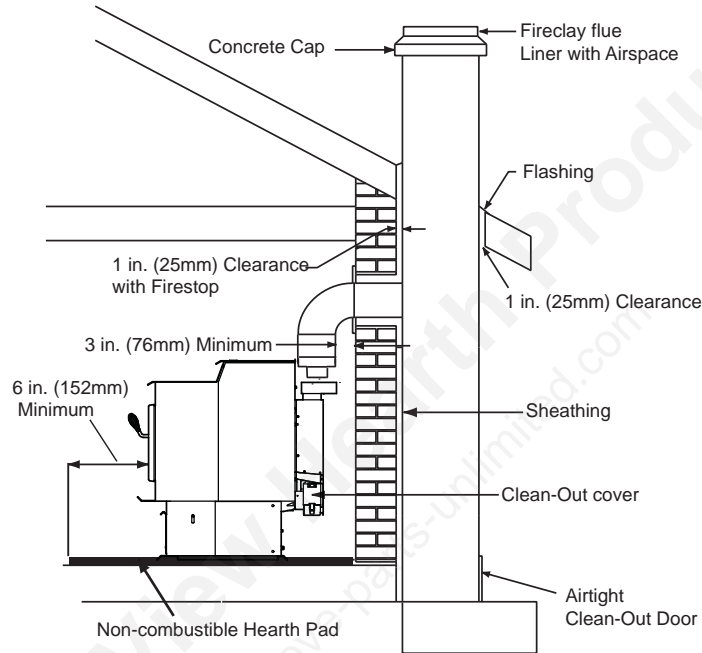

Figure 35.1

E. Alternate Masonry

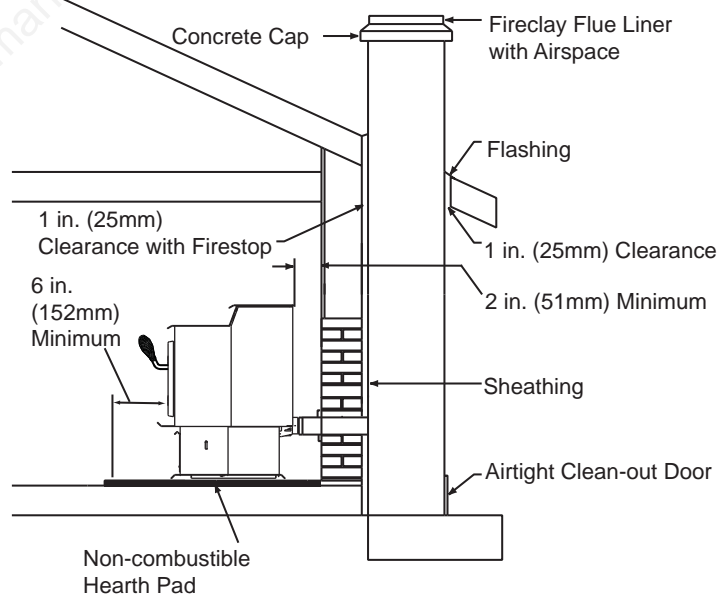

Figure 35.2

F. Through The Wall

Horizontal termination cap must be a minimum of 6 inches (152mm) from the wall. Approved for mobile home installations. Must use 3 or 4 inch (76-102mm) "L" or "PL" listed pellet venting or Listed double wall pipe and an authorized Outside Air Kit in mobile homes.

In Canada, where passage through a wall or partition of combustible construction is desired, the installation shall conform to CAN/CSA-B365

NOTICE:

Please note that while the minimum clearance for the termination cap is 6 inches (152mm) there is the possibility of soot build-up around the termination area. If this occurs we suggest to move the termination further away from the house to prevent it. The suggested minimum is 12 inches.

CAUTION

DO NOT DOWNWARD VENT.

The following will occur:

- The appliance will not vent properly
- Smoke spillage in the house
- Excessive sooting

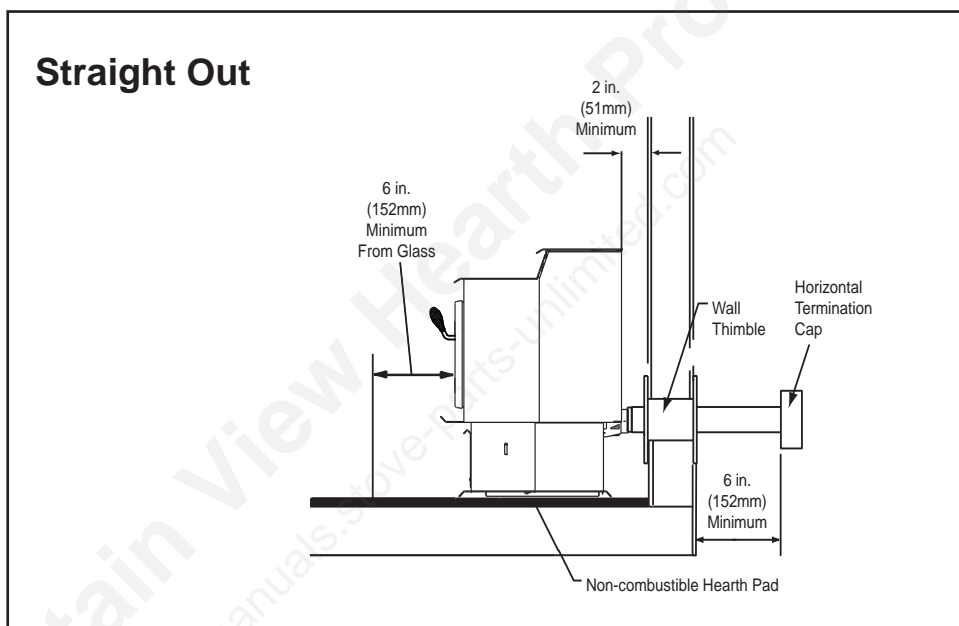

Figure 36.1

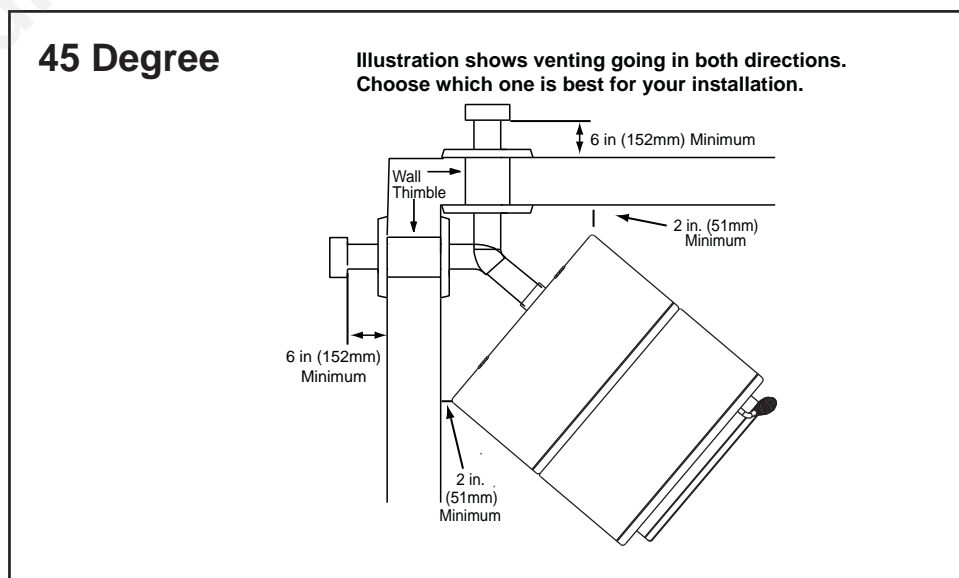



Figure 36.2



9 Mobile Home

A. Mobile Home Installation

You must use an authorized Outside Air Kit for installation in a mobile home.

1. An outside air inlet must be provided for the combustion air and must remain clear of leaves, debris, ice and/or snow. It must be unrestricted while the appliance is in use to prevent room air starvation which causes smoke spillage. Smoke spillage can also set off smoke alarms.
2. The combustion air duct system must be made of metal. It must permit zero clearance to combustible construction and prevent material from dropping into the inlet or into the area beneath the dwelling and contain a rodent screen.
3. The appliance must be secured to the mobile home structure by bolting it to the floor (using lag bolts) with two attachment points. Use the same holes that secured the appliance to the shipping pallet.
4. The appliance must be grounded with #8 solid copper grounding wire or equivalent, terminated at each end with an NEC approved grounding device.
5. Refer to Clearances to Combustibles and floor protection requirements on **pages 29 & 30** for listings to combustibles and appropriate chimney systems.
6. Use silicone to create an effective vapor barrier at the location where the chimney or other component penetrates to the exterior of the structure.
7. Follow the chimney manufacturer's instructions when installing the vent system for use in a mobile home.
8. Installation shall be in accordance with the Manufacturers Home & Safety Standard (HUD) CFR 3280, Part 24.

 WARNING
Installation must comply with Manufactured Home and Safety Standard (HUD), CFR 3280, Part 24.

 WARNING
 Asphyxiation Risk. NEVER INSTALL IN A SLEEPING ROOM. Consumes oxygen in the room.

CAUTION
THE STRUCTURAL INTEGRITY OF THE MOBILE HOME FLOOR, WALL AND CEILING/ROOF MUST BE MAINTAINED
Do NOT cut through:
<ul style="list-style-type: none">• Floor joist, wall, studs or ceiling trusses.• Any supporting material that would affect the structural integrity.

CAUTION
Never draw outside combustion air from:
<ul style="list-style-type: none">• Wall, floor or ceiling cavity• Enclosed space such as an attic, garage or crawl space.

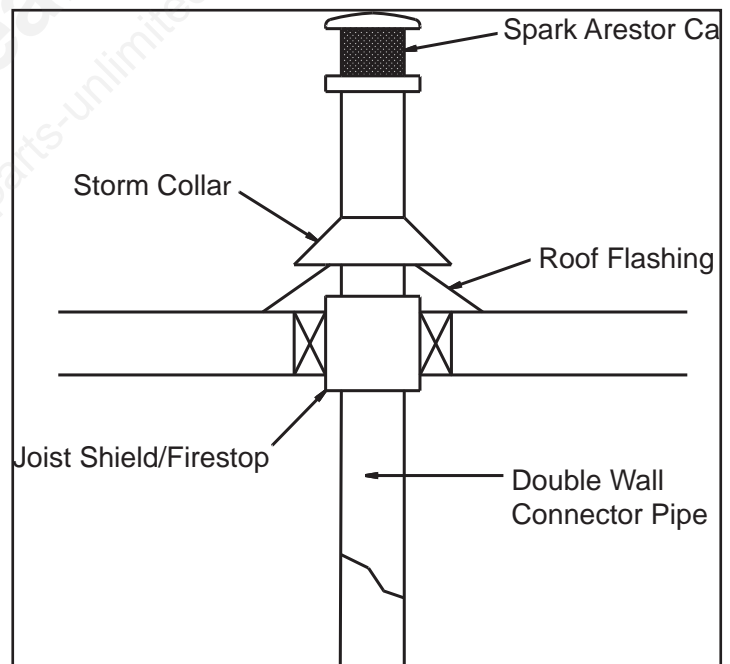

Figure 37.1

10 Appliance Set-Up

A. Outside Air Kit Instructions

There are two Outside Air Kits that will work with this appliance. One kit, 811-0872 uses a 2 inch flex hose (included) and uses hose clamps to secure the hose. The other kit, OAK-3, uses a 3 inch flex hose (not included) and uses wire ties to secure the hose.

Parts Included in 2 inch Kit 811-0872: 1 piece of 2 inch x 3 ft. flex hose, 2 hose clamps, 1 collar assembly, 1 termination cap assembly, trim ring, 1 intake air channel, fasteners (Discard the air intake channel, it is not needed for this appliance).

Parts Included in 3 inch Kit OAK-3: 2 wire ties, 1 collar assembly, 1 termination cap assembly, 1 trim ring, fasteners.

Tools Needed: Phillips Head screw driver; wire cutters; hole saw or jig saw, and the length of flex hose needed for your installation if using the 3 inch kit.

1. Measure distance from floor to air vent opening in appliance and mark location on wall.

Use saw to cut opening in wall.

2 inch kit: Cut a 2-1/2 to 3 inch opening on inside wall and a 3 to 3-1/2 inch opening on outside of house.

3 inch kit: Cut a 3-1/2 to 4 inch opening on inside wall and a 4 to 4-1/2 inch opening on outside of house.

2. Use wire tie or hose clamp depending on the Outside Air Kit to secure flex pipe to collar assembly.
3. Slide trim ring over flex pipe and run pipe through wall.
4. Attach flex pipe to outside termination cap with second wire tie or hose clamp.
5. Secure termination cap to outside surface.
6. Secure trim ring to interior wall.

CAUTION

Never draw outside combustion air from:

- Wall, floor or ceiling cavity
- "Enclosed space such as an attic, garage or crawl space.

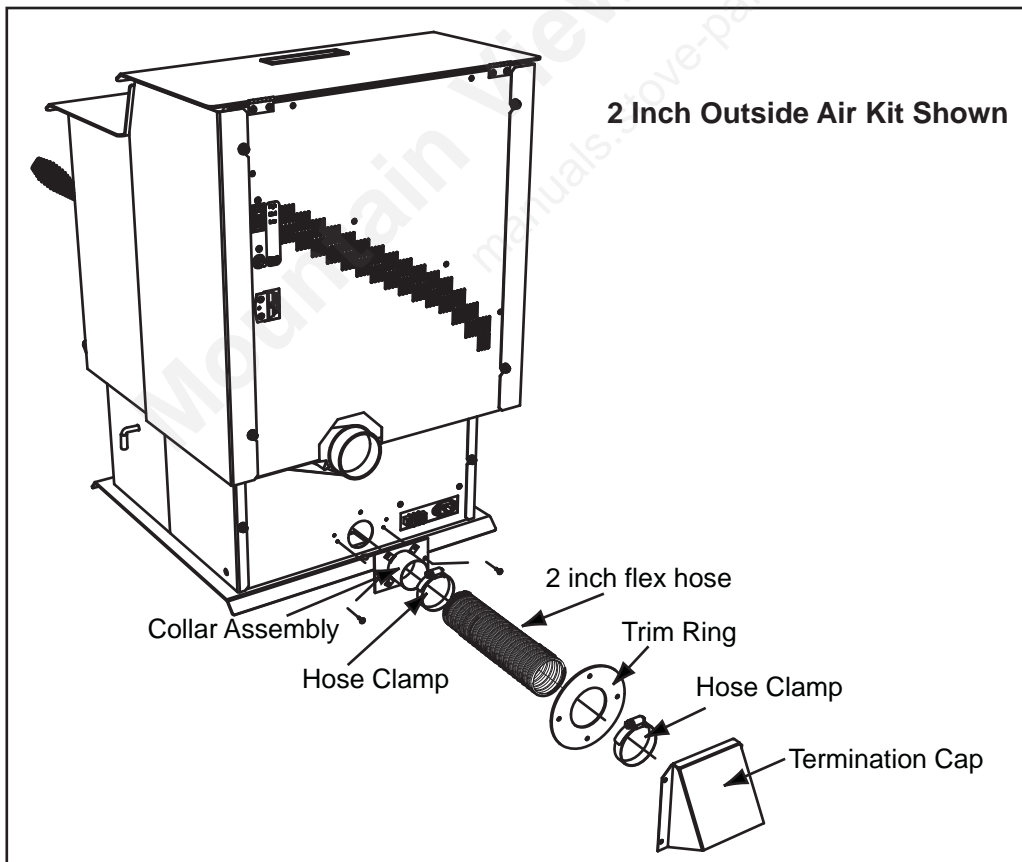

Figure 38.1 - 2 Inch Outside Air Kit Shown

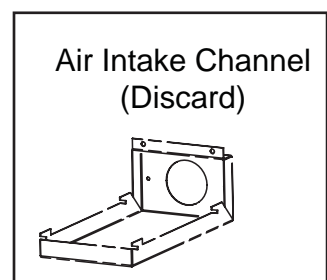

Figure 38.2

B. Top Vent Adapter Installation

3 to 3 inch Top Vent Adapter

3 to 6 inch Top Vent Offset Adapter

Installing the Top Vent Adapter

1. Put a layer of high temperature silicone on the 3 inch (76mm) exhaust outlet. **Do not put silicone inside of pipe.** **Figure 39.1**
2. Slide the top vent adapter onto the rear exhaust outlet and adjust the assembly to a vertical position. **Figure 39.1.**
3. Drill 4 holes with #26 drill bit (provided) into the back of the appliance using the outer shield as a pattern (make sure the assembly is vertical). **Figure 39.2.**
4. Install the 4 mounting screws.
5. Drill 2 holes with #26 drill bit through the rear exhaust outlet using the 2 holes already in the short horizontal pipe in the top vent adapter as a guide. Install the 2 screws. **Figure 39.1.**
6. Install the vent pipe into the top vent adapter (be sure to silicone all joints).
7. To clean the top vent adapter open the clean-out cover. **Figure 39.2.**

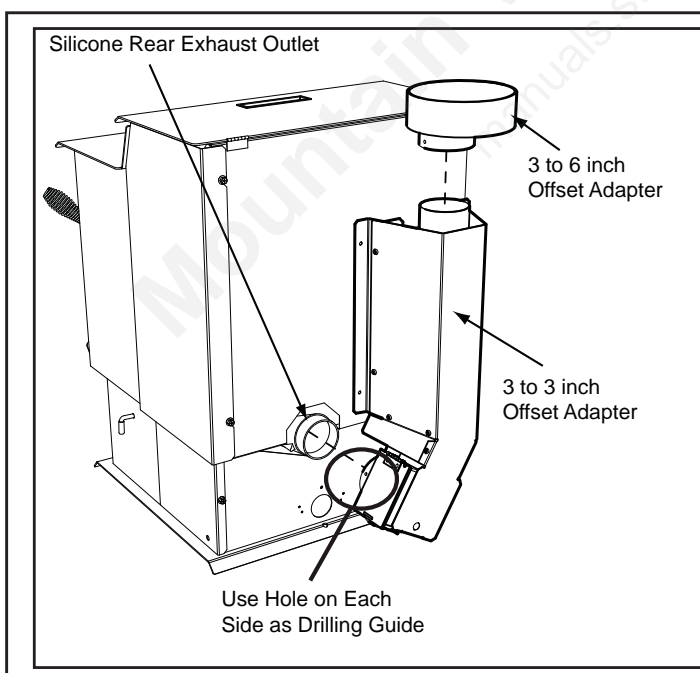

Figure 39.1

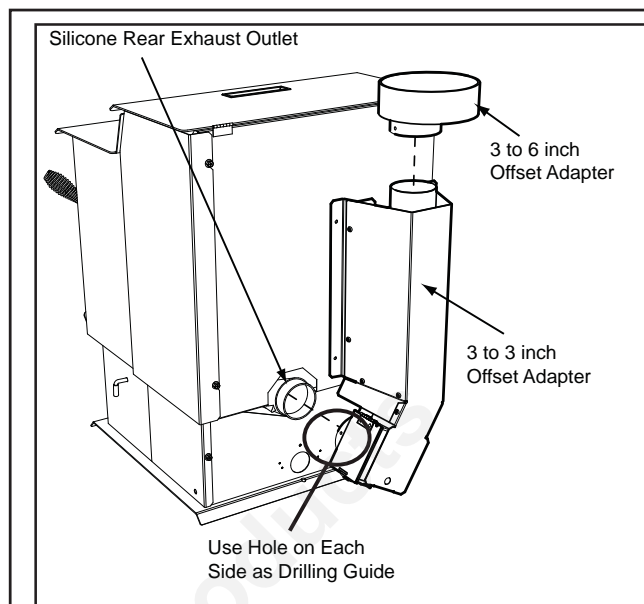

Figure 39.2

C. Rear Vent and Rear Vent to Top Vent Adapter Installation

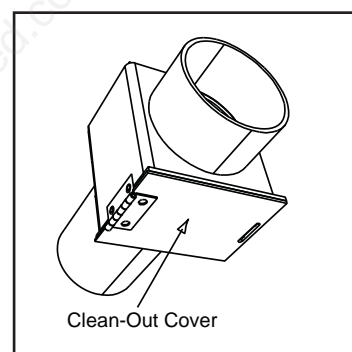

Figure 39.3 - Rear Vent Adapter

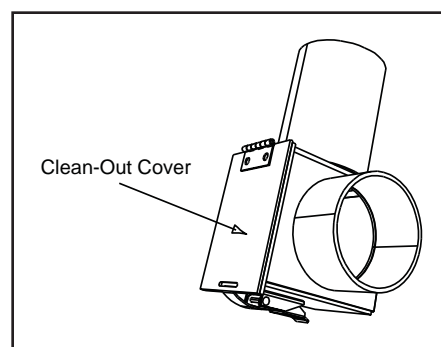

Figure 39.4 - Rear to Top Vent Adapter - 90°

1. Put a layer of high temperature silicone on the 3 inch (76mm) exhaust outlet. **Do not put silicone inside of pipe.** **Figure 39.1.**
2. Slide the adapter onto the rear exhaust outlet and adjust the assembly to the appropriate position.
3. Install the vent pipe into the adapter (be sure to silicone all joints)

D. Thermostat Installation

1. A low voltage thermostat is required to operate this pellet appliance. You may use the included wall mount thermostat (**Figure 40.2**) or purchase an optional programmable thermostat or remote control. It is equipped with an adjustable heat anticipator. The current rating is .05 amps. The anticipator needs to be adjusted to the lowest setting available.
2. When mounting a thermostat on a wall, be sure to follow your thermostat installation instructions carefully.

NOTE: Thermostat must be mounted level for accurate readings. The thermostat should be mounted on an inside wall and not in direct line with the appliance convection air.

NOTE: If the thermostat is located too close to the appliance, you may need to set the temperature setting slightly higher to maintain the desired temperature in your home.

3. There is a 4 screw terminal block located on the back lower left corner of the stove directly above the power cord inlet. The center 2 screws are for the thermostat wires. **Figure 40.1.**

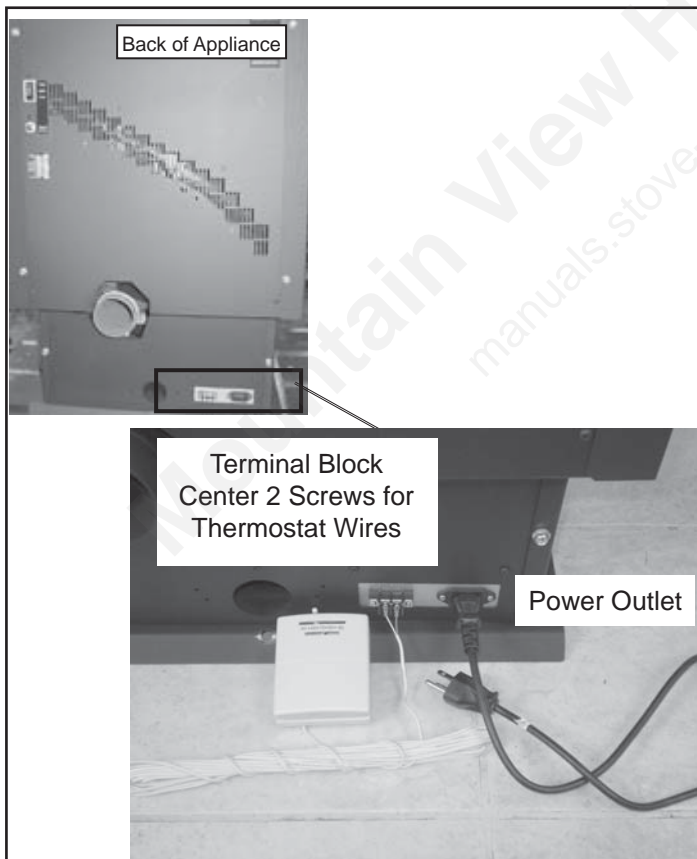



Figure 40.1

**CAUTION**

Shock hazard.

- Do NOT remove grounding prong from plug.
- Plug directly into properly grounded 3 prong receptacle.
- Route cord away from appliance.
- Do NOT route cord under or in front of appliance.



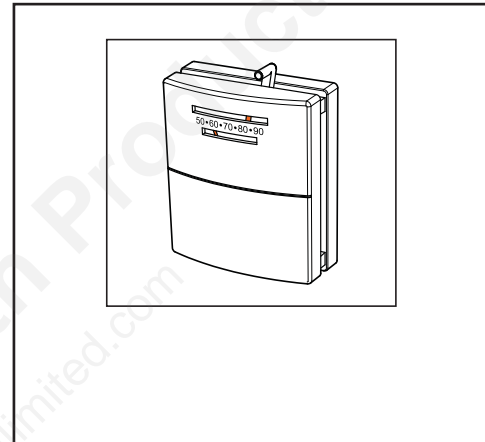

Figure 40.2

11 Troubleshooting

With proper installation, operation, and maintenance your appliance will provide years of trouble-free service. If you do experience a problem, this troubleshooting guide will assist a qualified service person in the diagnosis of a problem and the corrective action to be taken.

Symptom	Possible Cause	Corrective Action
Plug in appliance - No response.	No Power to outlet. 7 amp fuse defective or blown #3 snap disc tripped or defective. Control box is loose or defective.	Check circuit breaker at service panel. Replace fuse. Reset or replace snap disc. Reset or replace control box.
Call light on. No fire. No fuel in firepot.	Out of fuel. #2 snap disc may be defective or tripped. Vacuum switch not closing, no vacuum. Hopper lid open. Defective hopper switch. Missing or out of place hopper switch magnet. (CAB50) Control box defective.	Check hopper. Fill with fuel. Reset or replace snap disc. Check exhaust blower is plugged in and operating. Check vacuum switch is plugged in. Check vacuum hose is in good condition, clear and connected at both ends. Check thermocouple is in good condition and plugged in properly. Make sure venting system is clean. Make sure front door is closed. Check vacuum switch fitting on back of auger tube for blockage. Replace control box. Close Hopper Lid. Check hopper switch operation. Check/adjust magnet position.
Call light on. No fire. Partially burned fuel in firepot.	Firepot is dirty (missed ignition). Vent system plugged. Igniter chamber blocked	Clean firepot. Make sure there is no clinker in the firepot. Close firepot bottom plate/ Clinkers may have to be broken up with firepot clean-out tool or other means. Check flue vent for obstruction Check if firepot floor is closed all the way Clear igniter chamber using firepot clean-out tool
Call light on. No fire. Unburned pellets in firepot.	Firepot is dirty. Igniter chamber blocked. Igniter not working. Control box defective. Firepot floor open.	Clean firepot. Make sure there is not a clinker in the firepot. Clinkers may have to be pushed out of firepot with firepot clean-out tool or other means. Clear igniter chamber using firepot clean-out tool. Remove ash drawer to see if igniter is glowing red on start-up. Check igniter wires for good connection. Use a multimeter to check igniter for continuity. Replace igniter using instructions in manual. Replace control box.
Slow or smoky start-up.	Firepot is dirty. Igniter chamber blocked. Firepot floor partially open. Excessive amount of fuel at start-up.	Clean firepot. Make sure there is not a clinker in the firepot. Clinkers may have to be pushed out of firepot with firepot clean-out tool or other means. Check if firepot floor is closed all the way Reduce feed rate using feed rate adjustment control rod located inside hopper. Close firepot floor. Clear igniter chamber using firepot clean-out tool.

Troubleshooting

Symptom	Possible Cause	Corrective Action
Slow or smoky start-up (Cont'd)	Dirty exhaust and/or venting system. Wet fuel / poor quality fuel	Check for ash build up in unit, including behind rear panels, firebox, exhaust blower and venting. Replace fuel
Feed system fails to start	Out of fuel. #2 snap disc may be defective or tripped. Vacuum switch not closing. No vacuum. Defective vacuum switch Feed system jammed or blocked. Feed spring not turning with feed motor. Feed motor defective or not plugged in.	Check hopper, fill with fuel. Reset or replace snap disc Check vacuum fitting on auger tube for restrictions. Check door rope and replace if necessary. Check exhaust blower is plugged in and operating. Check vacuum switch is plugged in. Check vacuum hose is in good condition, clear and connected at both ends. Check thermocouple is in good condition and plugged in properly. Make sure venting system is clean. NOTE: High winds blowing into the venting system can pressurize the firebox causing loss of vacuum. Replace vacuum switch Empty hopper of fuel. Use a wet/dry vacuum cleaner to remove remaining fuel, from hopper, including feed tube. Check feed chute for obstructions. Remove feed assembly & check for obstruction. Check that set screw is tight on feed spring shaft at end of feed motor. Check connections on feed motor, replace if defective.
Amber light blinking	Thermocouple may have failed. Amber light will blink 3 times, pauses, and keeps repeating	Replace Thermocouple
No call light. Unit does not begin start sequence.	Thermostat not set to a high enough temperature. Snap disc #3 tripped or defective. No power. Fuse blown. Connections at thermostat and/or appliance not making proper contact. Defective thermostat or thermostat wiring. Control box defective.	Adjust thermostat above room temperature. Reset snap disc or replace if defective. Connect to power. Replace fuse. Check connections at thermostat and appliance. Temporarily jump connection to verify Replace thermostat or wiring. NOTE: To test thermostat and wiring, use a jumper wire at the thermostat block on the unit to by-pass thermostat and wiring. Replace control box.
Unit fails to shut off.	Call light on.	Turn thermostat off. If call light does not go out, disconnect thermostat wires from unit. If call light does go out, thermostat or wires are defective.

Troubleshooting

Symptoms	Possible Cause	Corrective Action
Convection blower fails to start.	#1 snap disc defective. Blower not plugged in. Blower is defective or object jammed in impeller. Control box is defective.	Replace snap disc. Check that blower is plugged into wire harness. Replace blower. Replace control box.
Exhaust blower fails to start.	Blower not plugged in. Intermittent electrical connection. Obstruction in blower. Blower is defective. Control box is defective.	Check that blower is plugged into wire harness. Verify fit of plug to outlet Clean exhaust system. Replace blower. Replace control box.
Exhaust blower does not shut off.	Control box is defective.	Replace control box.
Large, lazy flame, orange color. Black ash on glass.	Dirty appliance. Poor fuel quality, high ash content. Excessive amount of fuel. Control box is on the wrong setting.	Clean unit, including firepot and venting system. Clean exhaust path. Try a different brand of pellets. Reduce feed rate using feed rate adjustment control rod located inside hopper. "See owner's manual for correct setting for your model and how to adjust control box setting.
Nuisance shutdowns.	Low flame. Sawdust buildup in hopper. Feed motor is reversing. Feed motor is weak Feed bearing adjustment Defective thermocouple. Defective control box. Firepot more than 1/2 full.	Increase feed by opening feed rate adjustment control rod located inside hopper. Clean hopper, see page 14 . Check for good connections between feed motor and wire harness. Test feed motor torque. Adjust feed bearing Replace thermocouple. Replace control box. See page 16 for detailed instructions for "High Ash Fuel Content Management" Reduce feed rate
Appliance calls for heat. Call light illuminates. Exhaust blower starts. No feed or igniter.	Thermocouple is defective or not properly plugged in. Defective control box	Check connections on thermocouple or replace if defective. A flashing yellow light on the control box indicates a problem with the thermocouple. Replace control box.

12

Reference Materials

A. Component Function

1. Control Box



When describing the location of a component, it is always AS YOU FACE THE FRONT OF THE APPLIANCE.

- The control box is located on the lower left side of the appliance, behind the lower left side panel and above the junction box.
- There is a light located inside of the control box. The internal light will turn green when the appliance has reached a temperature of 200°F (93°C) in the firepot. and will turn red when it reaches 600°F (315°C).
- There is also an internal blue light located in the control box. When you plug in the appliance the blue light will automatically start blinking. For model PS35 the blue light should flash 6 times every 10 seconds for the first 60 seconds after power up. For models PS50 and CAB50 it should blink 2 times.

To set your control board on the correct number:

- Unplug the appliance.
- Using #2 Phillips screw driver, 3/8" wrench, or 3/8" socket loosen the three screws that hold the right upper and lower side panels in place. You do not need to remove the screws. Remove side panels by lifting up and out.
- Use a #2 Phillips screw driver to remove the control box retainer bracket and lift control box out of the junction box.
- Using a 1/4 inch flat head screw driver turn the rotary switch until the desired number is showing on the dial.
- Re install control box and plug in appliance.
- To confirm your selection is correct count the number of times the blue light flashes.

Example: If you are on setting 2 the control box will flash 2 times every 10 seconds for 1 minute.

See chart below for correct control box setting for your model.

Model	Factory Control Board Setting
PS 35	#6 (6 Flashes)
PS50 / CAB50	#2 (2 Flashes)

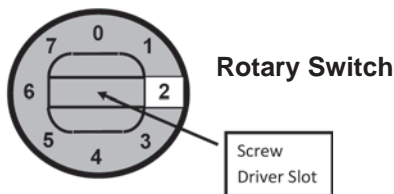

NOTE:

Do **NOT** open the control box. This will void the warranty. If you need to plug in or remove the control box you must first **unplug the appliance**.

2. Convection Blower

The convection blower is mounted at the bottom rear of the appliance. There are 2 impellers, one on each side of the motor. The convection blower pushes heated air through the heat exchange system into the room.

3. Exhaust Blower

The exhaust blower is mounted on the right side of the appliance. The exhaust blower is designed to pull the exhaust from the appliance and push it out through the venting system.

4. Feed System

The feed system is located on the right side of the appliance and can be removed as an entire assembly. The assembly includes the feed motor, mounting bracket, bearing and feed spring (auger). The hollow feed spring (auger) pulls pellets up the feed tube from the hopper area and drops them down the feed chute into the firepot.

5. Firepot

The firepot is made of high quality ductile iron and has a cleaning pull-out rod. The floor of the firepot opens for cleaning when you pull out the rod. Be sure that the floor returns to a completely closed position or your appliance will not operate properly.

6. Fuse

The fuse is located on the side of the junction box above to the red call light. The fuse will blow should a short occur and shut off power to the appliance.

7. Heat Output Switch

The heat output switch is located on the upper right back panel. The function of the heat output switch is to regulate the burn rates; low, medium and high settings.

8. Hopper Switch

The hopper switch is located in the upper right hand corner of the hopper. This switch is designed to shut down the feed motor whenever the hopper lid is opened.

9. Igniter

The igniter is mounted on the base of the firepot. Combustion air travels over the red hot igniter creating super heated air that ignites the pellets.

10. Junction Box And Wiring Harness

The junction box is located on the lower left side of the appliance, behind the left side panel. The junction box and wiring harness are replaced as one component.

11. Power Supply

The power outlet is located behind the control box on the back of the appliance, lower left corner. Check the wall receptacle for 120 volt, 60 Hz (standard current). Make sure the outlet is

grounded and has the correct polarity. A good surge protector is recommended.

12. Red Call Light

The red call light is on the side of the junction box, below the fuse. The function of the red call light is to indicate that the thermostat is calling for heat.

13. Reset Button

The reset button is located on the back of the appliance in the upper right corner below the heat output control switch. The function of the button is to momentarily open the thermostat circuit, which restarts the system.

14. Thermocouple

The thermocouple is located on top of the firepot inside the thermocouple cover (ceramic protection tube). The thermocouple sends a millivolt signal to the control box indicating the preset temperatures of the green and red lights have been obtained.

15. Thermostat

The appliance is designed to run on a 12 volt AC thermostat. The heat anticipator should be set on the lowest setting available.

16. Snap Disc #1 (Convection Blower) 110°F

Snap disc #1 is located on the right side of the appliance behind the right side panel. There are 2 purple wires connected to

it. This snap disc turns the convection blower on and off as needed. Power is always present at snap disc #1.

17. Snap Disc #2 (Fuel Delivery Interrupt) 175°F

Snap disc #2 is located on the center of the convection plenum above the convection blower. There is an orange and a black wire connected to it. This snap disc will turn off the feed system which will turn off the appliance if an over fire condition should occur or if the convection blower should fail to operate. If this occurs you will have to manually reset the snap disc.

18. Snap Disc #3 (Back Burn Protector) 250°F

Snap disc #3 is mounted on the back of the auger tube in the center of the appliance and has a reset button. There are two grey wires connected to it. To access it remove the right side panel. If the fire tries to burn back into the feed system or push exhaust up the feed tube, this snap disc will shut the entire system off. This disc must be manually reset.

19. Vacuum Switch

The vacuum switch is located on the lower right side of the appliance behind right side panel. There are two red wires attached to it. This switch turns the feed system on when vacuum is present in the firebox. The vacuum switch is a safety device to shut off the feed motor if the exhaust or the heat exchanger system is dirty or plugged or if the firebox door is open.

20. Wiring Harness

See Figure 45.1 below.

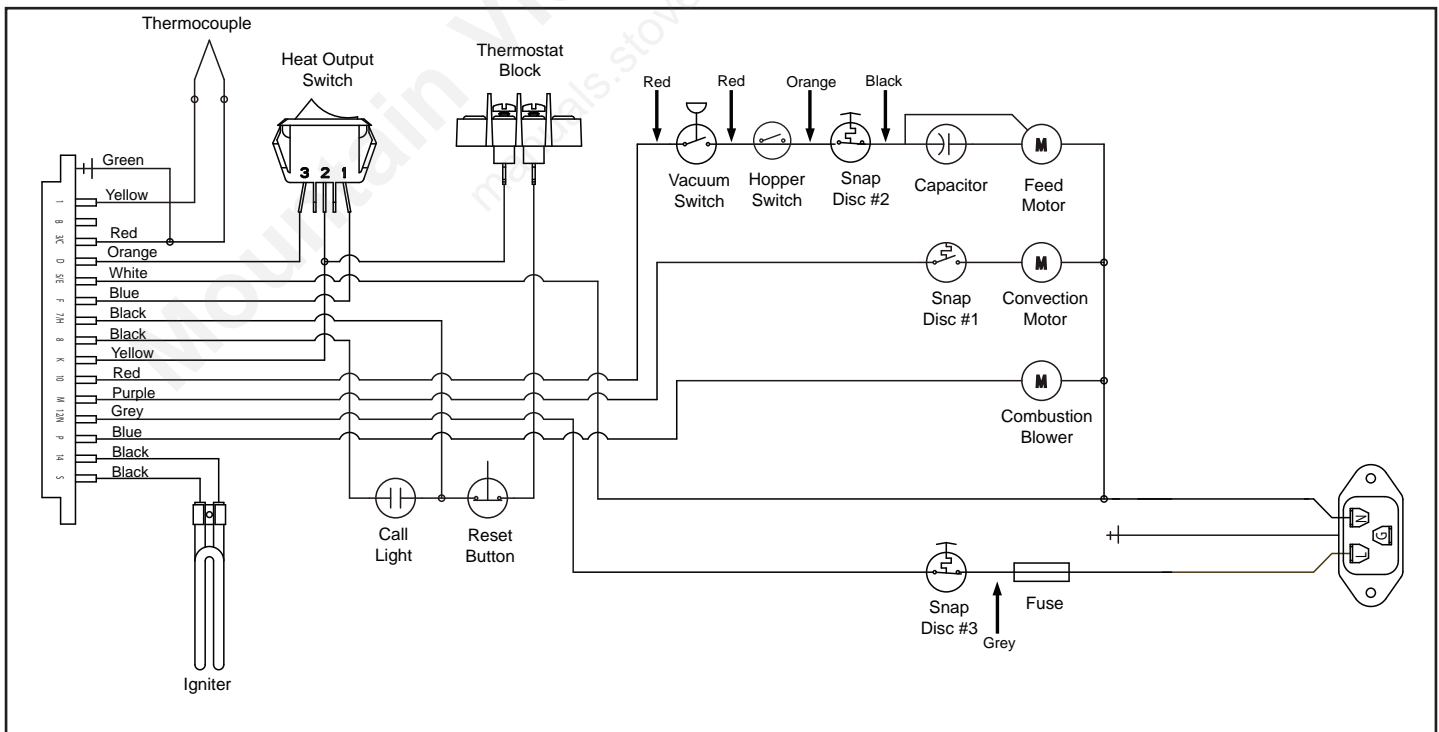

Figure 45.1

B. Component Locations

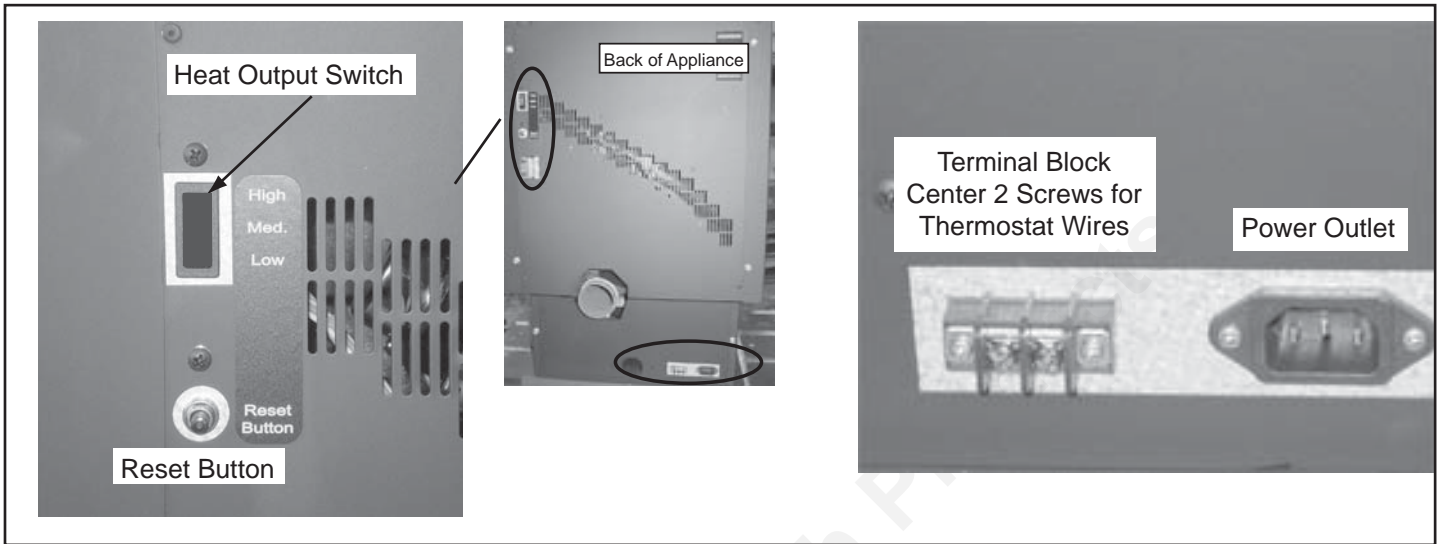

Figure 46.1

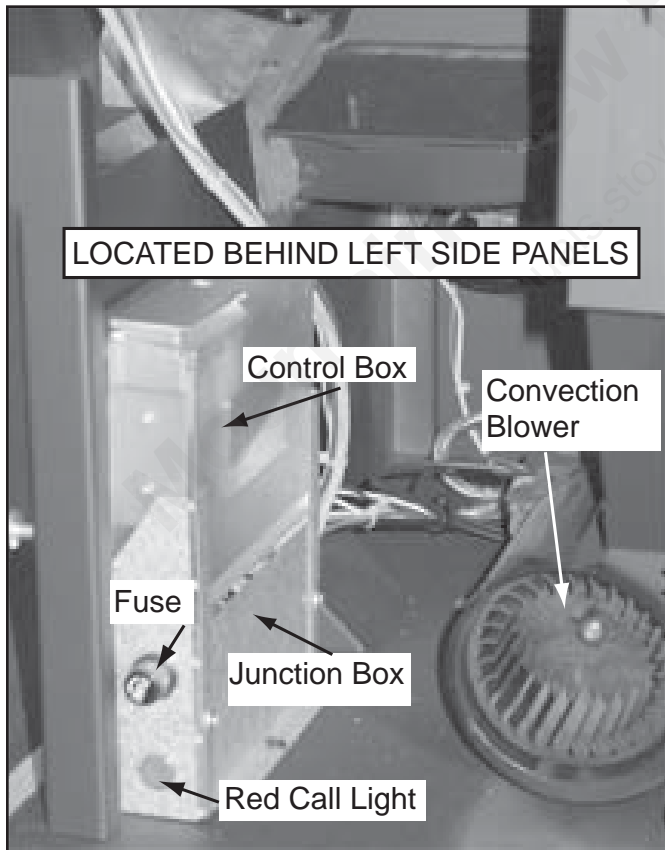

Figure 46.2

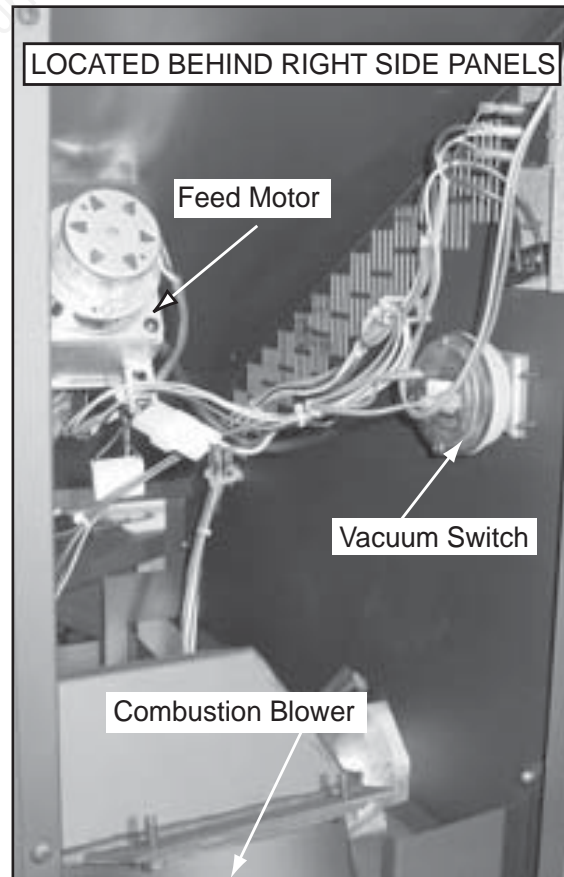

Figure 46.3



J. CONTACT INFORMATION:

**Hearth & Home Technologies
1445 North Highway
Colville, WA 99114
Division of HNI INDUSTRIES**

Please contact your Heatilator dealer with any questions or concerns.

For the number of your nearest Heatilator dealer, please visit
www.heatilator.com or www.heatilatorecochoice.com.

For Consumer Care 1-877-427-3316

Prior to calling, please have the model and serial number of the unit you are calling about.
This information can be found at the rear of the unit.

CAUTION



DO NOT DISCARD THIS MANUAL

- Important operating and maintenance instructions included.
- Read, understand and follow these instructions for safe installation and operation.
- Leave this manual with party responsible for use and operation.



We recommend that you record the following pertinent information for your heating appliance.

Date purchased/installed: _____

Serial Number: _____ Location on appliance: _____

Dealership purchased from: _____ Dealer phone: _____

Notes: _____

This product may be covered by one or more of the following patents: (United States) 6830000 and 5582117 or other U.S. and foreign patents pending.