

# hearthator® ECO CHOICE™

## PELLET STOVE SERVICE MANUAL



### ⚠️ WARNING

#### Fire Risk.

Hearth & Home Technologies disclaims any responsibility for, and the warranty will be voided by, the following actions:

- Installation and use of any damaged appliance.
- Modification of the appliance.
- Installation other than as instructed by Hearth & Home Technologies.
- Installation and/or use of any component part not approved by Hearth & Home Technologies.
- Operating appliance without fully assembling all components.
- Operating appliance without legs attached (if supplied with unit).
- Do NOT Overfire

**Or any such action that may cause a fire hazard.**

**NOTE:** Hearth & Home Technologies, manufacturer of this appliance, reserves the right to alter its products, their specifications and/or price without notice.



### ⚠️ CAUTION

#### Shock and Smoke Hazard

- Turn down thermostat, let appliance completely cool and exhaust blower must be off. Now you can unplug appliance before servicing.
- Smoke spillage into room can occur if appliance is not cool before unplugging.
- Risk of shock if appliance not unplugged before servicing appliance.



### ⚠️ CAUTION

#### Shock hazard.

- Do NOT remove grounding prong from plug.
- Plug directly into properly grounded 3 prong receptacle.
- Unplug cord before doing any checks or repairs.
- Do NOT touch wires while unit is plugged in.

# ECO CHOICE PELLET STOVE SERVICE MANUAL

---

---

## TABLE OF CONTENTS

<u>SECTION</u>	<u>PAGE</u>
TROUBLE-SHOOTING SYMPTOMS	3-5
OPERATION FLOW CHART	6-9
FEED MOTOR TROUBLE-SHOOTING	10
IGNITER TROUBLE-SHOOTING	11
EXHAUST BLOWER TROUBLE-SHOOTING	12
CONVECTION BLOWER TROUBLE-SHOOTING	13
POWER SUPPLY TROUBLE-SHOOTING	14-15
THERMOSTAT TROUBLESHOOTING	16
THERMOCOUPLE TESTING	17
FIREPOT & EXHAUST SYSTEM TROUBLE-SHOOTING	18-20
WIRE DIAGRAM	21
GENERAL SPECIFICATIONS	22
CHECK-OFF SHEET	23
CLEANING & MAINTENANCE TIPS	24-25

# ECO CHOICE PELLET STOVE SERVICE MANUAL

---

---

## TROUBLE SHOOTING & REPAIR

### A. PLUG IN STOVE -- NO RESPONSE

- 1) CHECK THE POWER SUPPLY FOR 115 VOLTS
- 2) CHECK THE FUSE IN THE JUNCTION BOX (7 AMP)
- 3) CHECK SNAP DISC #3 FOR POWER
- 4) CHECK CONTROL BOX

### B. CALL LIGHT ON -- NO FIRE -- NO FUEL IN FIREPOT



- 1) CHECK HOPPER FOR BRIDGING OF PELLETS
- 2) PUSH RESET BUTTON & ADJUST FEED ADJUSTMENT PLATE
- 3) CHECK TO MAKE SURE THE FRONT DOOR IS CLOSED
- 4) CHECK VENTING SYSTEM FOR OBSTRUCTIONS
- 5) CHECK VACUUM SWITCH AND VACUUM HOSE
- 6) CHECK FEED MOTOR
- 7) CHECK EXHAUST BLOWER
- 8) CHECK HOPPER SWITCH

### C. CALL LIGHT ON -- NO FIRE -- PARTIALLY BURNED FUEL IN POT

- 1) CHECK FIREPOT AND CLEAN
- 2) CHECK THERMOCOUPLE
  - \*GREEN LIGHT----- 2.7 mV ( $\pm$ .5mV)
  - \*RED LIGHT----- 12.0 mV ( $\pm$  1mV)
- 3) CHECK INITIAL FEED TIME (60 SECONDS)

### D. CALL LIGHT ON -- NO FIRE -- FUEL IN FIREPOT

- 1) CHECK FIREPOT FOR "CLINKER" MATERIAL
- 2) CLEAN FIREPOT
- 3) CHECK IGNITER
- 4) CHECK CONTROL BOX

	 <b>CAUTION</b>
Shock hazard.	
<ul style="list-style-type: none"><li>• Do NOT remove grounding prong from plug.</li><li>• Plug directly into properly grounded 3 prong receptacle.</li><li>• Unplug cord before doing any checks or repairs.</li><li>• Do NOT touch wires while unit is plugged in.</li></ul>	

# ECO CHOICE PELLET STOVE SERVICE MANUAL

---

---

## TROUBLE SHOOTING & REPAIR

### E. SLOW OR SMOKEY START UP

- 1) CLEAN FIREPOT
- 2) FEED ADJUSTMENT PLATE MAY BE SET TOO HIGH
- 3) CHECK EXHAUST BLOWER AND HEAT EXCHANGER

### F. STOVE RUNS FOR 18 MINUTES -- THEN STOPS FEEDING FUEL

- 1) CHECK THERMOCOUPLE
  - \*GREEN LIGHT (2.7 mVDC)
  - \*RED LIGHT (12.0 mVDC)
- 2) ADJUST FEED ADJUSTMENT PLATE FOR LARGER FIRE
- 3) CHECK THERMOCOUPLE COVER
  - \*COVER NEEDS TO TOUCH THE END OF THE T-COUPLE WIRE
  - \*COVER SHOULD EXTEND 1" INTO FIREPOT
- 4) CHECK CONTROL BOX

### G. FEED SYSTEM FAILS TO START

- 1) CHECK FRONT DOOR AND MAKE SURE IT IS CLOSED
- 2) CHECK TO SEE IF CALL LIGHT IS ON
- 3) CHECK THERMOSTAT, #2 SNAP DISC, AND HOPPER SWITCH
- 4) CHECK FEED MOTOR AND VACUUM SWITCH
- 5) CHECK EXHAUST SYSTEM FOR OBSTRUCTIONS

### H. THERMOSTAT WILL NOT START UNIT

- 1) CHECK THERMOSTAT WIRES FOR CONTINUITY
- 2) CHECK THE HOPPER SWITCH
- 3) CHECK THE RESET BUTTON
- 4) CHECK FOR POWER TO THE STOVE
- 5) CHECK CONTROL BOX

	<b>CAUTION</b>
Shock hazard.	
<ul style="list-style-type: none"><li>• Do NOT remove grounding prong from plug.</li><li>• Plug directly into properly grounded 3 prong receptacle.</li><li>• Unplug cord before doing any checks or repairs.</li><li>• Do NOT touch wires while unit is plugged in.</li></ul>	

# ECO CHOICE PELLET STOVE SERVICE MANUAL

---

---

## TROUBLE SHOOTING & REPAIR

### I. UNIT FAILS TO SHUT OFF

- 1) CHECK THERMOSTAT AND THERMOSTAT WIRE
- 2) CHECK THE JUNCTION BOX & WIRE HARNESS
- 3) CHECK THE CONTROL BOX

### J. CONVECTION BLOWER KEEPS RUNNING OR FAILS TO START

- 1) CHECK #1 SNAP DISC
- 2) CHECK CONVECTION BLOWER
- 3) CHECK FOR VOLTAGE TO THE #1 SNAP DISC

### K. STOVE CYCLES ON AND OFF -- THERMOSTAT ALWAYS ON

- 1) CHECK CONTROL BOX
- 2) CHECK VACUUM SWITCH OR HOPPER SWITCH
- 3) CHECK WIRING FOR LOOSE CONNECTIONS



### L. LARGE FIRE, ASH BUILD UP & DIRTY GLASS

- 1) CHECK FIREPOT, MAY NEED TO BE CLEANED
- 2) CLEAN EXHAUST AND HEAT EXCHANGER SYSTEM
- 3) ADJUST FEED ADJUSTMENT PLATE IN THE HOPPER
- 4) CHECK CONTROL BOX FEED TIMES

### M. STOVE IGNITES -- GOES OUT -- CALL LIGHT STILL ON

“ STOVE IS INCONSISTANT IN OPERATION “

- 1) INSPECT THERMOCOUPLE AND ITS POSITION OVER THE POT
- 2) CHECK THE FEED MOTOR
- 3) ADJUST FEED ADJUSTMENT PLATE FOR A LARGER FIRE
- 4) CHECK THE EXHAUST AND HEAT EXCHANGER SYSTEM
- 5) CHECK THE VACUUM SWITCH OR HOPPER SWITCH

	 <b>CAUTION</b>
	<p>Shock hazard.</p> <ul style="list-style-type: none"><li>• Do NOT remove grounding prong from plug.</li><li>• Plug directly into properly grounded 3 prong receptacle.</li><li>• Unplug cord before doing any checks or repairs.</li><li>• Do NOT touch wires while unit is plugged in.</li></ul>

# ECO CHOICE PELLET STOVE SERVICE MANUAL

## OPERATION FLOWCHART

FOLLOW THE PELLET STOVE OPERATION AND VERIFY THAT EACH COMPONENT IS COMING ON.

IF THAT COMPONENT IS NOT COMING ON, REFER TO THE TROUBLESHOOTING SECTION FOR THAT COMPONENT.

AFTER THAT PART HAS BEEN FIXED, PROCEED WITH THE OPERATION OF THE STOVE AND MAKE SURE THAT EACH OPERATION IS TAKING PLACE.

### (START)

THERMOSTAT  
TURNS ON.  
RED CALL LIGHT  
ILLUMINATES  
ON THE STOVE.  
**1**



Thermostat



CALL LIGHT

EXHAUST  
BLOWER TURNS  
ON.  
**2**

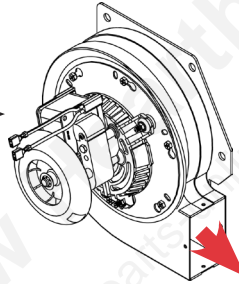

IGNITER TURNS  
ON.  
**3**



VACUUM SWITCH  
CLOSES.  
**4**

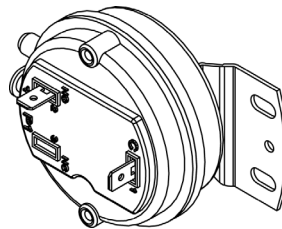

### **ITEMS TO CHECK: POSSIBLE PROBLEMS OR FAILED COMPONENT**

**BOX 1: THERMOSTAT, THERMOSTAT WIRE, WIRE HARNESS, OR CONTROL BOX**

**BOX 2: EXHAUST BLOWER, CONTROL BOX, WIRE HARNESS**

**BOX 3: IGNITER, CONTROL BOX, WIRE HARNESS**

**BOX 4: VACUUM SWITCH, VACUUM HOSE, VENT OR HEAT EXCHANGER BLOCKAGE, DOOR SEAL**

# ECO CHOICE PELLET STOVE SERVICE MANUAL

## OPERATION FLOWCHART

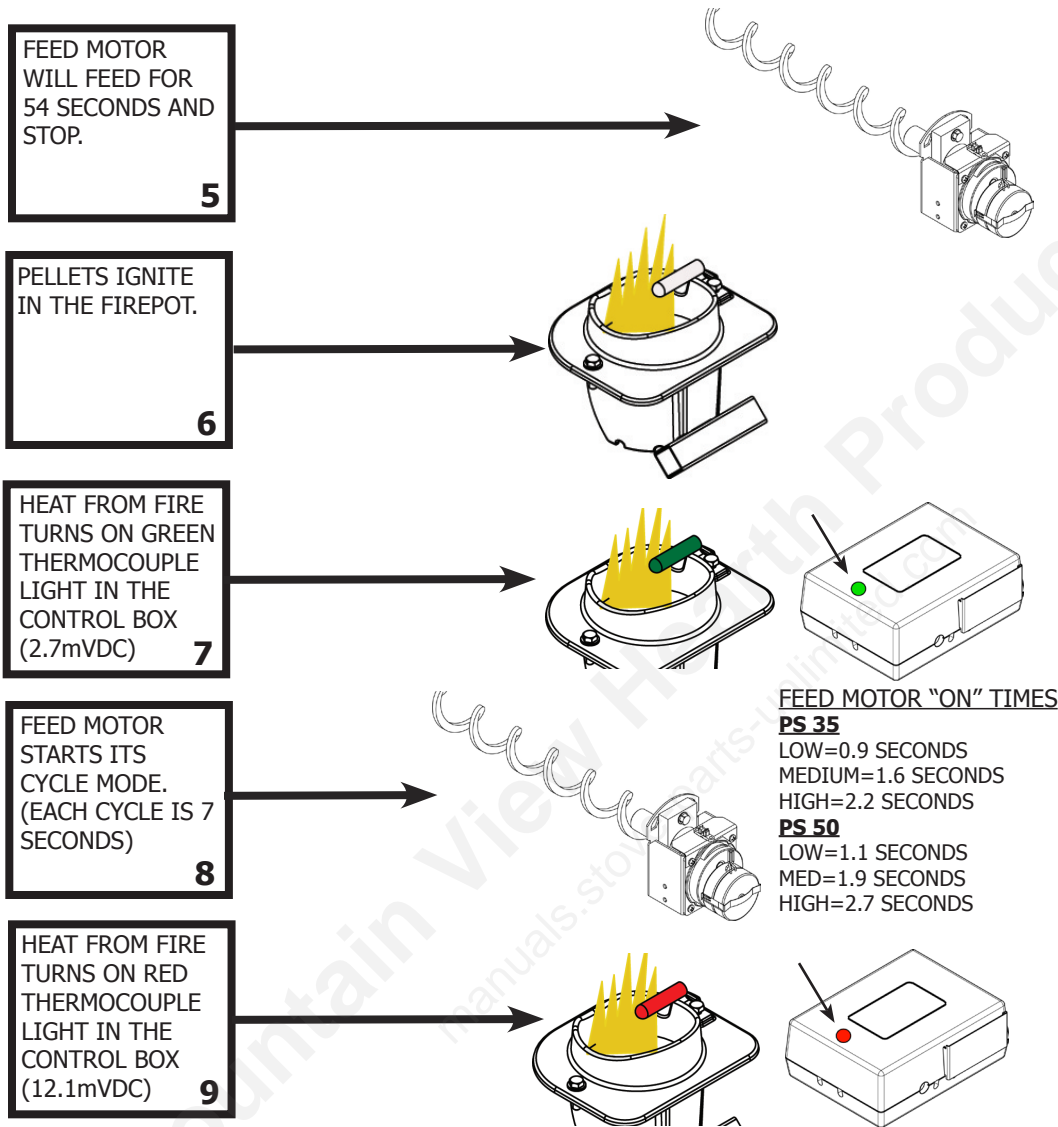

### **ITEMS TO CHECK: POSSIBLE PROBLEMS OR FAILED COMPONENT**

**BOX 5: #2 SNAP DISC, WIRE CONNECTIONS, FEED MOTOR, CONTROL BOX, HOPPER SWITCH**

**BOX 6: FIREPOT, FEED ADJUSTMENT PLATE, VENT PIPE BLOCKAGE**

**BOX 7: THERMOCOUPLE, THERMOCOUPLE CONNECTIONS, CONTROL BOX, WIRE HARNESS**

**BOX 8: CONTROL BOX, THERMOCOUPLE, FEED ADJUSTMENT PLATE**

**BOX 9: CONTROL BOX, THERMOCOUPLE, FEED ADJUSTMENT PLATE**

# ECO CHOICE PELLET STOVE SERVICE MANUAL

## OPERATION FLOWCHART

(CONTINUED)

IGNITER TURNS OFF.  
**10**

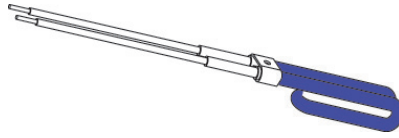

HEAT FROM FIRE CLOSES #1 SNAP DISC.  
**11**



CONVECTION BLOWER TURNS ON.  
**12**

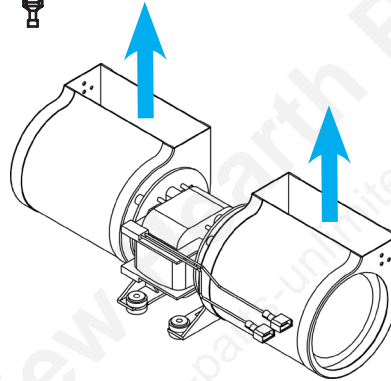

ROOM REACHES TEMPERATURE.  
**13**

THERMOSTAT TURNS OFF  
**14**



Thermostat

### **ITEMS TO CHECK: POSSIBLE PROBLEMS OR FAILED COMPONENT**

**BOX 10: CONTROL BOX**

**BOX 11: #1 SNAP DISC, WIRE CONNECTIONS, WIRE HARNESS, CONVECTION BLOWER**

**BOX 12: CONVECTION BLOWER, WIRE CONNECTIONS**

**BOX 13: FEED ADJUSTMENT PLATE, PELLET FUEL, CONTROL BOX**

**BOX 14: THERMOSTAT, THERMOSTAT WIRE**

# ECO CHOICE PELLET STOVE SERVICE MANUAL

## OPERATION FLOWCHART

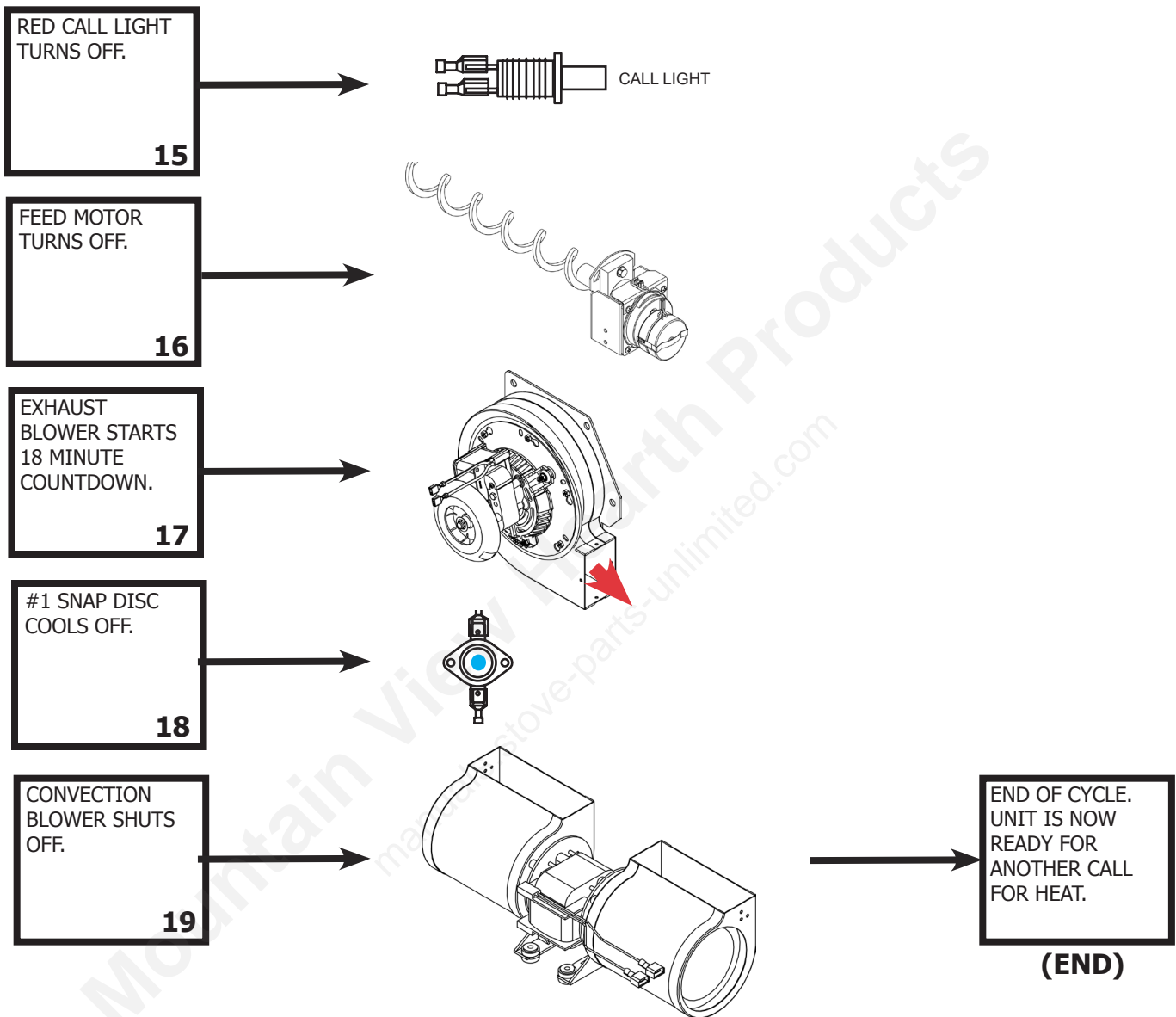

### **ITEMS TO CHECK: POSSIBLE PROBLEMS OR FAILED COMPONENT**

**BOX 15: THERMOSTAT, THERMOSTAT WIRE, WIRE HARNESS**

**BOX 16: CONTROL BOX**

**BOX 17: CONTROL BOX, WIRE HARNESS**

**BOX 18: #1 SNAP DISC**

**BOX 19: #1 SNAP DISC, WIRE HARNESS**

# ECO CHOICE PELLET STOVE SERVICE MANUAL

## FEED MOTOR TROUBLE-SHOOTING

1) TURN ON THERMOSTAT CIRCUIT AND MAKE SURE THAT THE CALL LIGHT IS ON

2) CHECK FOR POWER AT THE VACUUM SWITCH:

A. IF NO POWER FROM RED WIRE-----CHECK CONTROL BOX OR WIRE HARNESS

B. POWER ON RED FROM HARNESS BUT NO POWER ON RED GOING TO HOPPER SWITCH -----CHECK VACUUM SWITCH OR VENT SYSTEM

3) CHECK FOR POWER AT THE ORANGE WIRE ON THE HOPPER SWITCH

A. IF NO POWER FROM ORANGE WIRE----CHECK WIRE HARNESS OR HOPPER SWITCH

B. IF POWER IS PRESENT-----CHECK #2 SNAP DISC

4) CHECK FOR POWER AT THE BLACK WIRE FROM #2 SNAP DISC:

A. IF NO POWER FROM BLACK WIRE----CHECK WIRE HARNESS OR SNAP DISC

B. IF POWER IS PRESENT-----CHECK FEED MOTOR

**NOTE: REMEMBER THAT THE FEED CIRCUIT INITIAL FEED TIME IS 60 SECONDS. PUSH THE RESET BUTTON BEFORE EACH TEST.**

### FEED MOTOR CIRCUIT

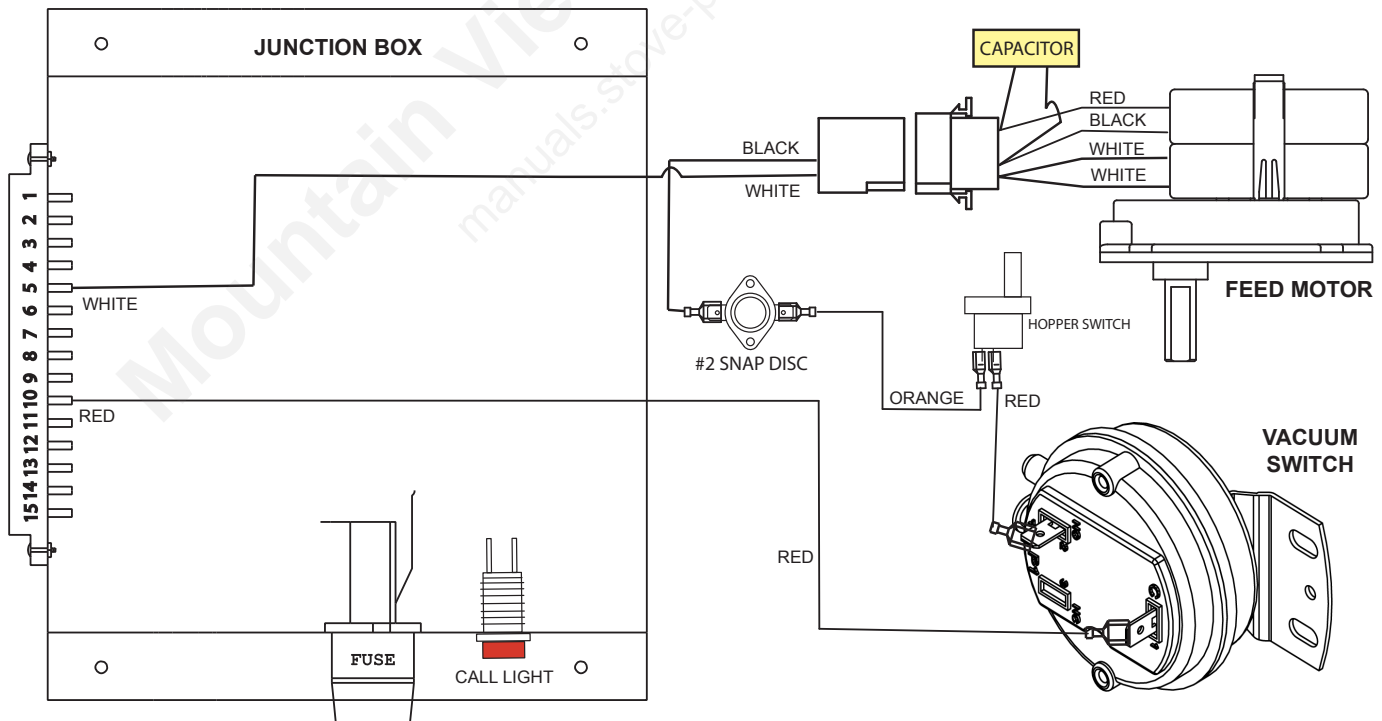



# ECO CHOICE PELLET STOVE SERVICE MANUAL

## IGNITER TROUBLE-SHOOTING

- 1) TURN ON THE THERMOSTAT CIRCUIT AND MAKE SURE THE CALL LIGHT IS ON
- 2) CHECK FOR POWER AT THE IGNITER:
  - A. IF NO POWER-----CHECK THE WIRE HARNESS OR REPLACE THE CONTROL BOX
  - B. IF POWER IS PRESENT-----REPLACE THE IGNITER

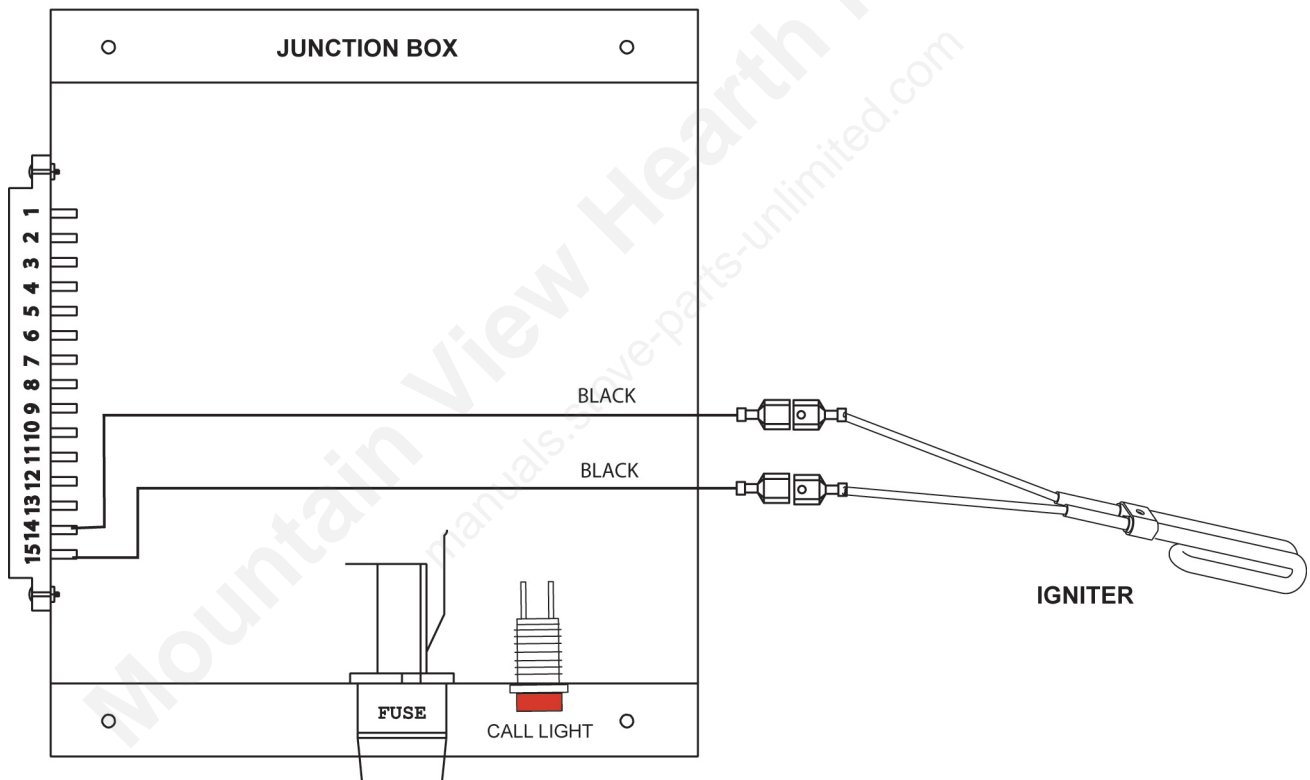
### IGNITER CIRCUIT



	 <b>CAUTION</b>
	<p>Shock hazard.</p> <ul style="list-style-type: none"><li>• Do NOT remove grounding prong from plug.</li><li>• Plug directly into properly grounded 3 prong receptacle.</li><li>• Unplug cord before doing any checks or repairs.</li><li>• Do NOT touch wires while unit is plugged in.</li></ul>

# ECO CHOICE PELLET STOVE SERVICE MANUAL

## EXHAUST BLOWER TROUBLE-SHOOTING

- 1) TURN ON THE THERMOSTAT CIRCUIT AND MAKE SURE THE CALL LIGHT IS ON
- 2) CHECK FOR POWER AT THE BLUE WIRE ON THE CONNECTOR

OPEN CIRCUIT VOLTAGE AT THE BLUE CONNECTOR WILL BE 115 V ON THE HIGH SETTING ONLY

CLOSED CIRCUIT VOLTAGE WILL BE: **(PS35)** 115 V (HIGH) 109 V (MEDIUM) 103 V (LOW)

**(PS50)** 115 V (HIGH) 104 V (MEDIUM) 91 V (LOW)

\*\*\*NOTE: LOW & MEDIUM VOLTAGES WILL VARY DEPENDING ON THE VOLTAGE FROM THE HOME.

A. IF POWER IS PRESENT-----REPLACE THE EXHAUST BLOWER

B. IF NO POWER-----CHECK THE WIRE HARNESS OR REPLACE THE CONTROL BOX

**NOTE: OPEN CIRCUIT VOLTAGE IS MEASURED WITH THE BLOWER DISCONNECTED FROM THE WIRE HARNESS. CLOSED CIRCUIT VOLTAGE IS MEASURED WITH THE BLOWER HOOKED UP TO THE HARNESS. ONE LEAD FROM THE VOLTMETER MUST BE CONNECTED TO THE BLUE WIRE ON THE MOTOR AND THE OTHER LEAD CONNECTED TO THE WHITE WIRE FROM THE POWER SUPPLY.**

### EXHAUST BLOWER CIRCUIT

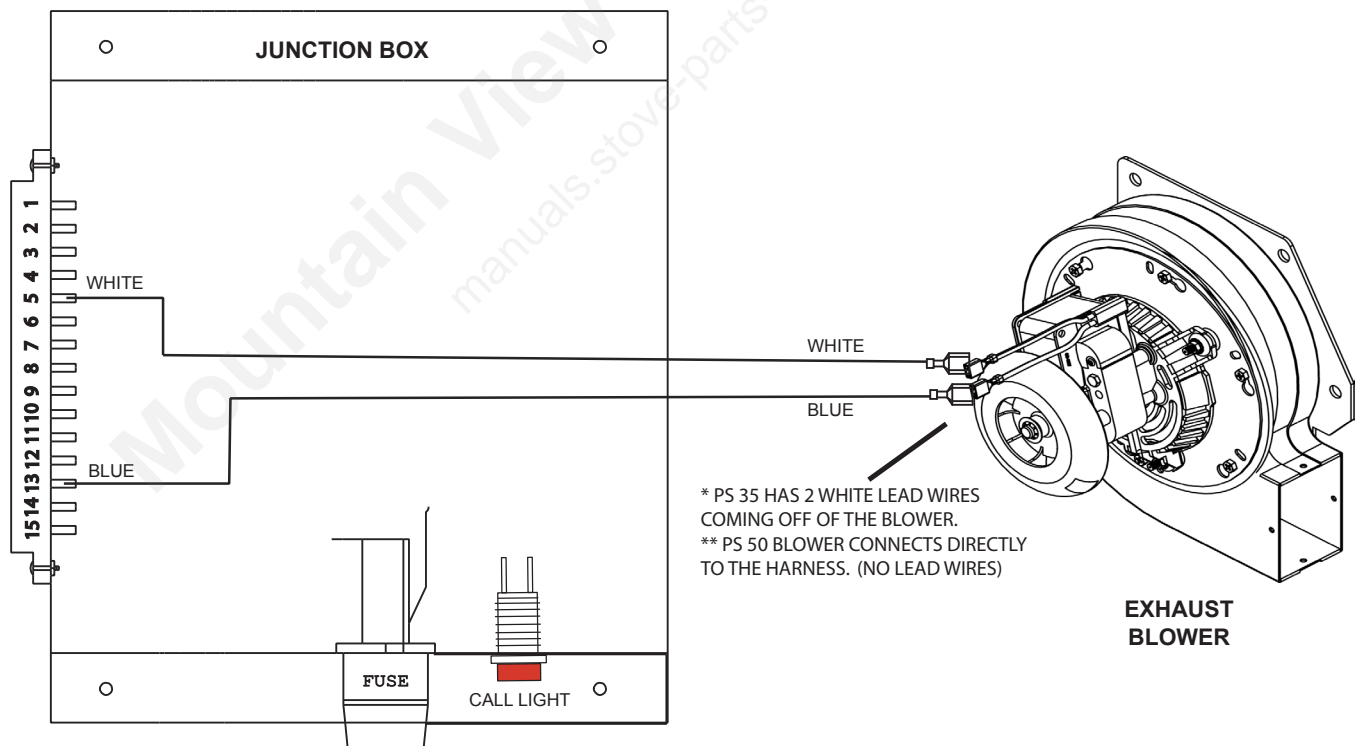

# ECO CHOICE PELLET STOVE SERVICE MANUAL

## CONVECTION BLOWER TROUBLE-SHOOTING

1) CHECK FOR POWER AT THE PURPLE WIRE FROM THE #11 PIN AT THE SNAP DISC  
OPEN CIRCUIT VOLTAGE TO ONE SIDE OF SNAP DISC WILL BE 115 V FOR THE HIGH SETTING ONLY

CLOSED CIRCUIT VOLTAGE WILL BE: **(PS35)** 115 V (HIGH) 94 V (MEDIUM) 80 V (LOW)

**(PS50)** 115 V (HIGH) 85 V (MEDIUM) 75 V (LOW)

\*\*\*NOTE: LOW & MEDIUM VOLTAGES WILL VARY DEPENDING ON THE VOLTAGE FROM THE HOME.

A. IF POWER IS PRESENT ON BOTH SIDES OF THE DISC: CHECK THE WIRE HARNESS OR REPLACE THE CONVECTION BLOWER (Stove must be hot to create a closed circuit on the snap disc.)

B. IF POWER IS PRESENT ON JUST ONE SIDE: REPLACE THE SNAP DISC

C. IF NO POWER IS PRESENT: CHECK THE FUSES & WIRE HARNESS OR REPLACE CONTROL BOX

**NOTE: THE VOLT METER MUST HAVE ONE LEAD CONNECTED TO THE WHITE NEUTRAL WIRE FROM THE POWER SUPPLY TO BE ABLE TO READ THE CORRECT VOLTAGE AT THE SNAP DISC. A JUMPER WIRE CAN BE USED ON #1 SNAP DISC TO CREATE A CLOSED CIRCUIT.**

### CONVECTION BLOWER CIRCUIT

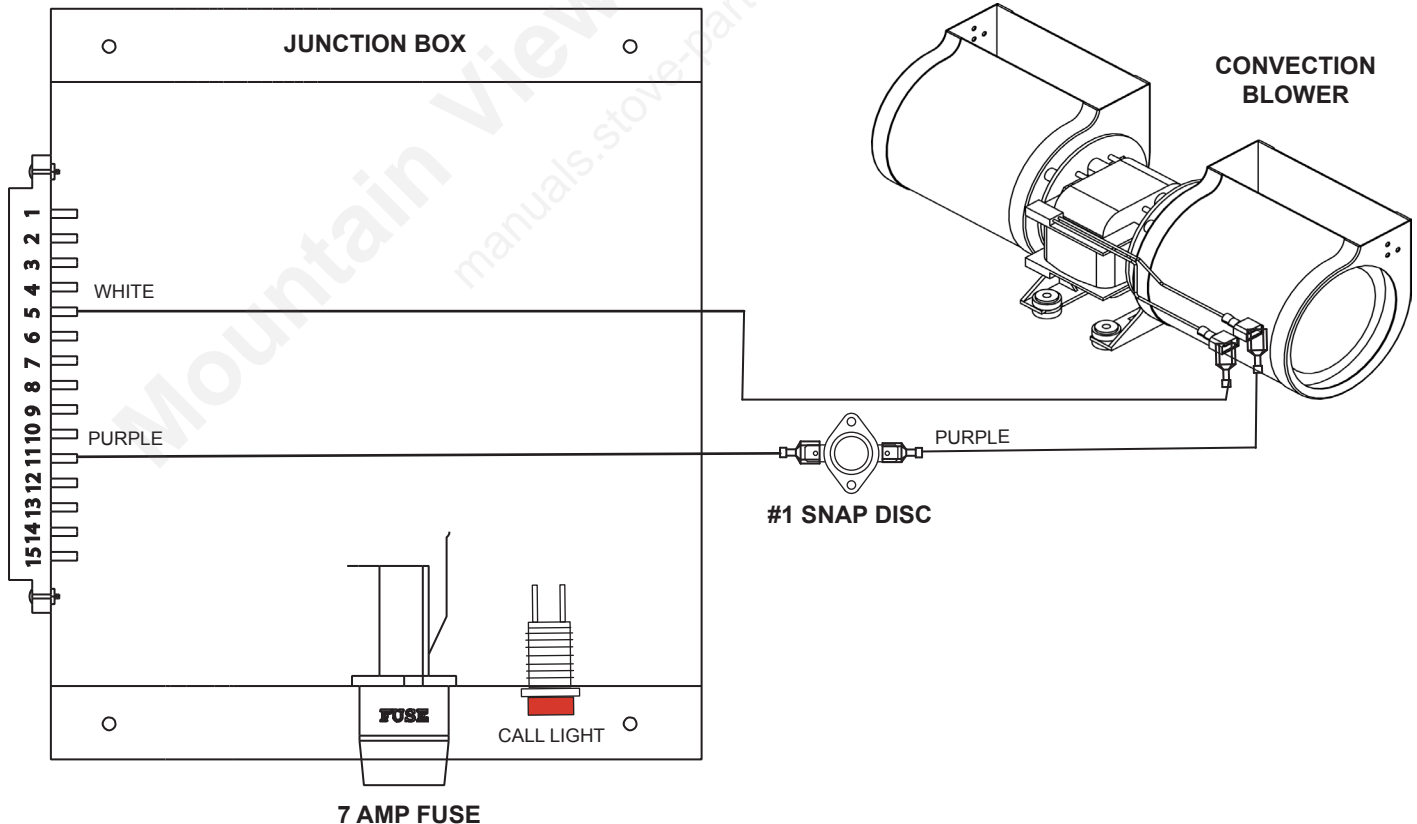

# ECO CHOICE PELLET STOVE SERVICE MANUAL

## POWER SUPPLY TROUBLE-SHOOTING

### 1) CHECK FOR POWER AT THE BLACK WIRE FROM THE POWER CORD. (SEE FIG. 1)

- A. IF NO POWER-----CHECK OUTLET OR REPLACE POWER CORD
- B. IF POWER IS PRESENT, CONTINUE TO STEP 2

### 2) CHECK FOR POWER AT THE GREY WIRE ON THE 7 AMP FUSE HOLDER. (SEE FIG. 2)

- A. IF NO POWER-----REPLACE THE FUSE OR THE FUSE HOLDER
- B. IF POWER IS PRESENT, CONTINUE TO STEP 3

### 3) CHECK FOR POWER AT THE GREY WIRES ON SNAP DISC #3. (SEE FIG. 3)

- A. IF NO POWER-----RESET THE SNAP DISC OR REPLACE IT
- B. IF POWER IS PRESENT---CHECK FOR CONTINUITY AT PIN 5 (WHITE WIRE) TO POWER CORD

(FIG.4 & 5) OR REPLACE THE CONTROL BOX

## POWER SUPPLY

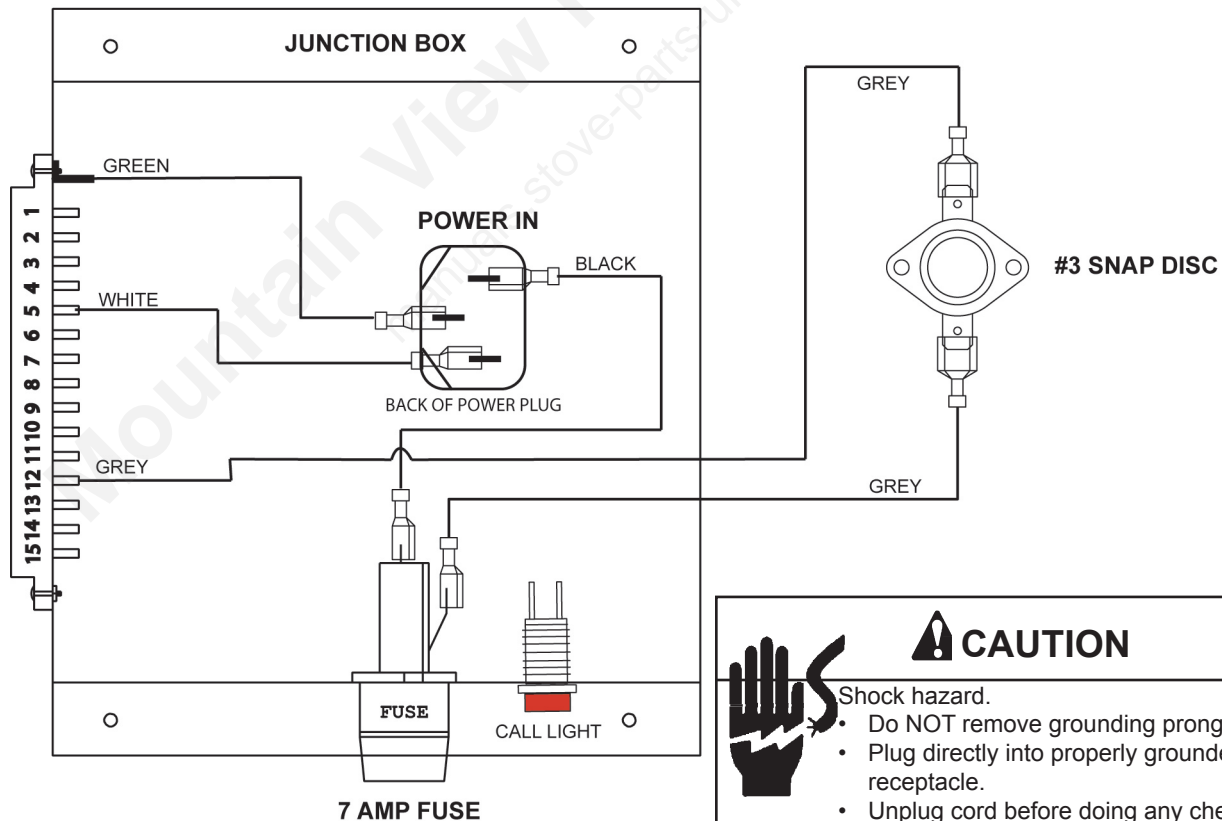

**CAUTION**

Shock hazard.

- Do NOT remove grounding prong from plug.
- Plug directly into properly grounded 3 prong receptacle.
- Unplug cord before doing any checks or repairs.
- Do NOT touch wires while unit is plugged in.

# ECO CHOICE PELLET STOVE SERVICE MANUAL

## POWER SUPPLY TESTING

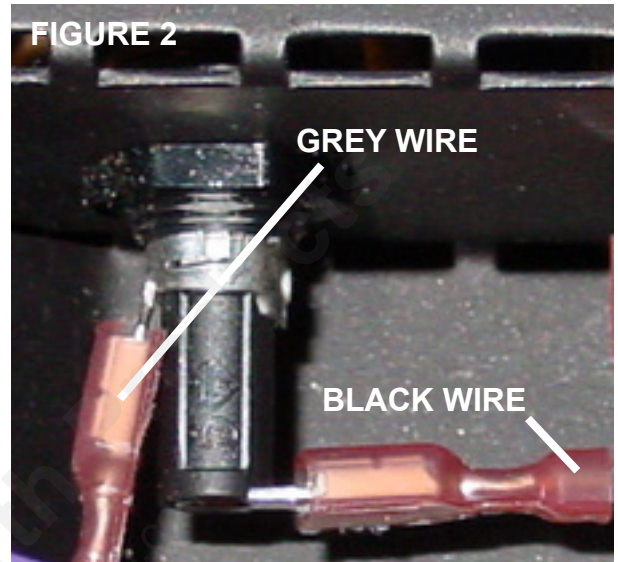
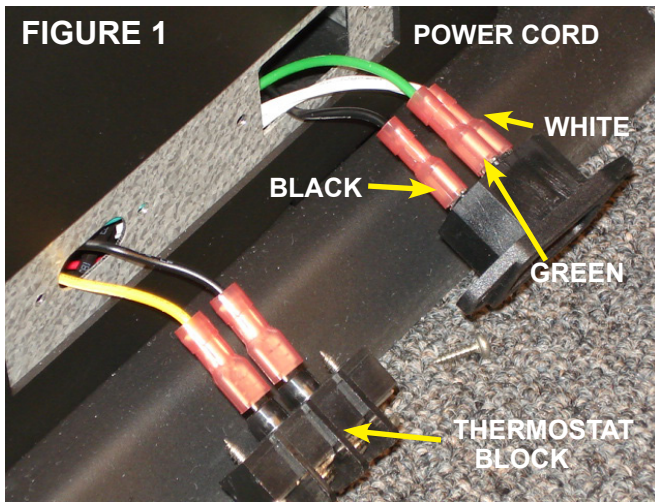

7 AMP FUSE HOLDER

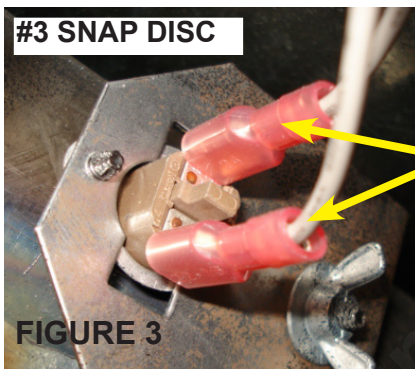

CHECK FOR POWER ON BOTH SIDES.

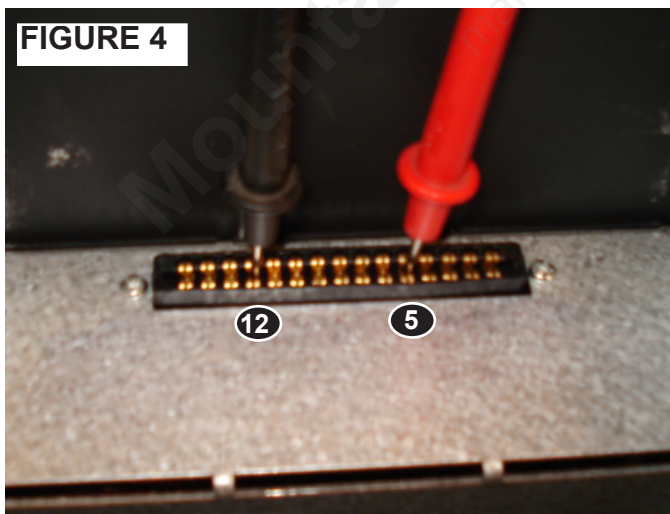

### TO CHECK FOR CONTINUITY:

- 1) PUT A JUMPER WIRE ON THE END OF THE POWER CORD. (SEE FIGURE 5)
- 2) SET THE VOLT METER TO OHMS AND PUT THE PROBES ON PIN 5 & PIN 12. (SEE FIGURE 4) IF THE CIRCUIT IS COMPLETE, THE READING SHOULD BE "0".



# ECO CHOICE PELLET STOVE SERVICE MANUAL

## THERMOSTAT CIRCUIT TROUBLE-SHOOTING

- 1) UNPLUG THE STOVE & REMOVE THE CONTROL BOX
- 2) TURN ON THE THERMOSTAT & MAKE SURE THE ACCESSORY JUMPER IS IN PLACE
- 3) CHECK FOR CONTINUITY AT PIN 7 & PIN 9 ON THE JUNCTION BOX  
IF THE CIRCUIT HAS CONTINUITY: REPLACE THE CONTROL BOX  
IF NO CONTINUITY, CONTINUE TO THE NEXT STEP
- 4) INSTALL A JUMPER WIRE ON THE THERMOSTAT & CHECK FOR CONTINUITY AT PIN 7 & PIN 9  
IF THE CIRCUIT HAS CONTINUITY: REPLACE THE THERMOSTAT  
IF NO CONTINUITY, CONTINUE TO THE NEXT STEP
- 5) REMOVE THE THERMOSTAT WIRES FROM THE THERMOSTAT BLOCK & INSTALL A JUMPER WIRE  
IF THE CIRCUIT HAS CONTINUITY: REPLACE THE THERMOSTAT WIRE  
IF NO CONTINUITY, CONTINUE TO THE NEXT STEP
- 6) INSTALL A JUMPER WIRE ON THE T-STAT BLOCK & THE RESET BUTTON. CHECK CONTINUITY (7&9)  
IF THE CIRCUIT HAS CONTINUITY: REPLACE THE RESET BUTTON  
IF NO CONTINUITY: REPLACE THE JUNCTION BOX/WIRE HARNESS

### THERMOSTAT CIRCUIT

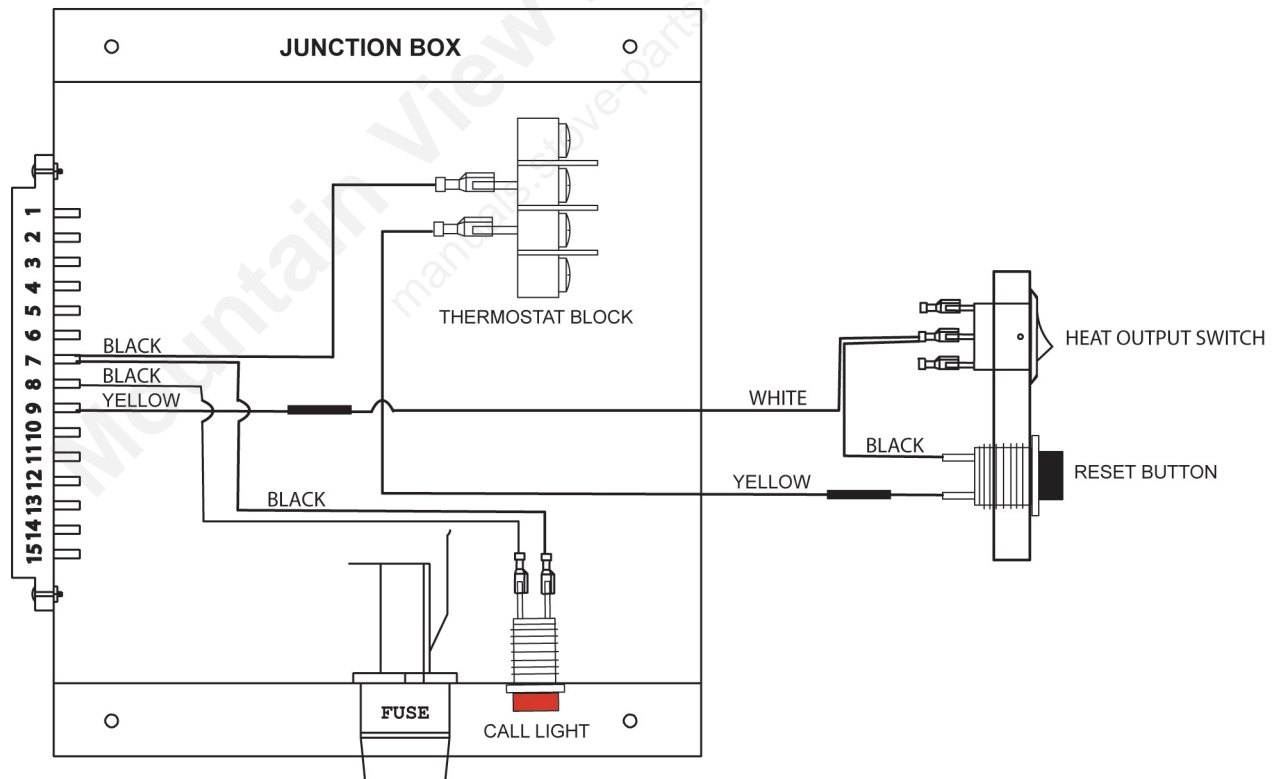

# ECO CHOICE PELLET STOVE SERVICE MANUAL

## THERMOCOUPLE TESTING

THE THERMOCOUPLE IS MADE UP OF TWO DISSIMILAR METALS THAT WHEN JOINED TOGETHER PRODUCE A SMALL AMOUNT OF ELECTRICITY WHEN HEAT IS APPLIED. THE HOTTER THE FIRE THE HIGHER THE VOLTAGE THAT IS PRODUCED. THIS THERMOCOUPLE WILL TOP OUT AT AROUND 30 MILLIVOLTS (DC) WHILE THE STOVE IS BURNING ON HIGH. THE FUNCTION OF THE THERMOCOUPLE IS TO SENSE THE TEMPERATURE IN THE FIREPOT. IF THE THERMOCOUPLE IS FRACTURED, IT WILL NOT PRODUCE VOLTAGE.

ALSO, AN **AMBER LIGHT** IN THE CONTROL WILL FLASH IF THE CIRCUIT IS OPEN OR IF THE THERMOCOUPLE IS FRACTURED.

### 1) ATTACH A DIGITAL VOLT METER TO THE TWO THERMOCOUPLE CONNECTORS ON THE HARNESS

NOTE: BE SURE TO SET THE METER TO MILLIVOLTS (DC) AND A JUMPER WIRE MAY NEEDED TO CHECK MILIVOLTS WHILE THE THERMOCOUPLE IS HOOKED UP.

### 2) APPLY HEAT TO THE THERMOCOUPLE TIP IN THE FIREPOT

IF THE THERMOCOUPLE STARTS PRODUCING VOLTAGE: CHECK TERMINAL CONNECTIONS ON THE WIRE HARNESS OR REPLACE THE CONTROL BOX.

IF NO VOLTAGE FROM THE THERMOCOUPLE: REPLACE THE THERMOCOUPLE

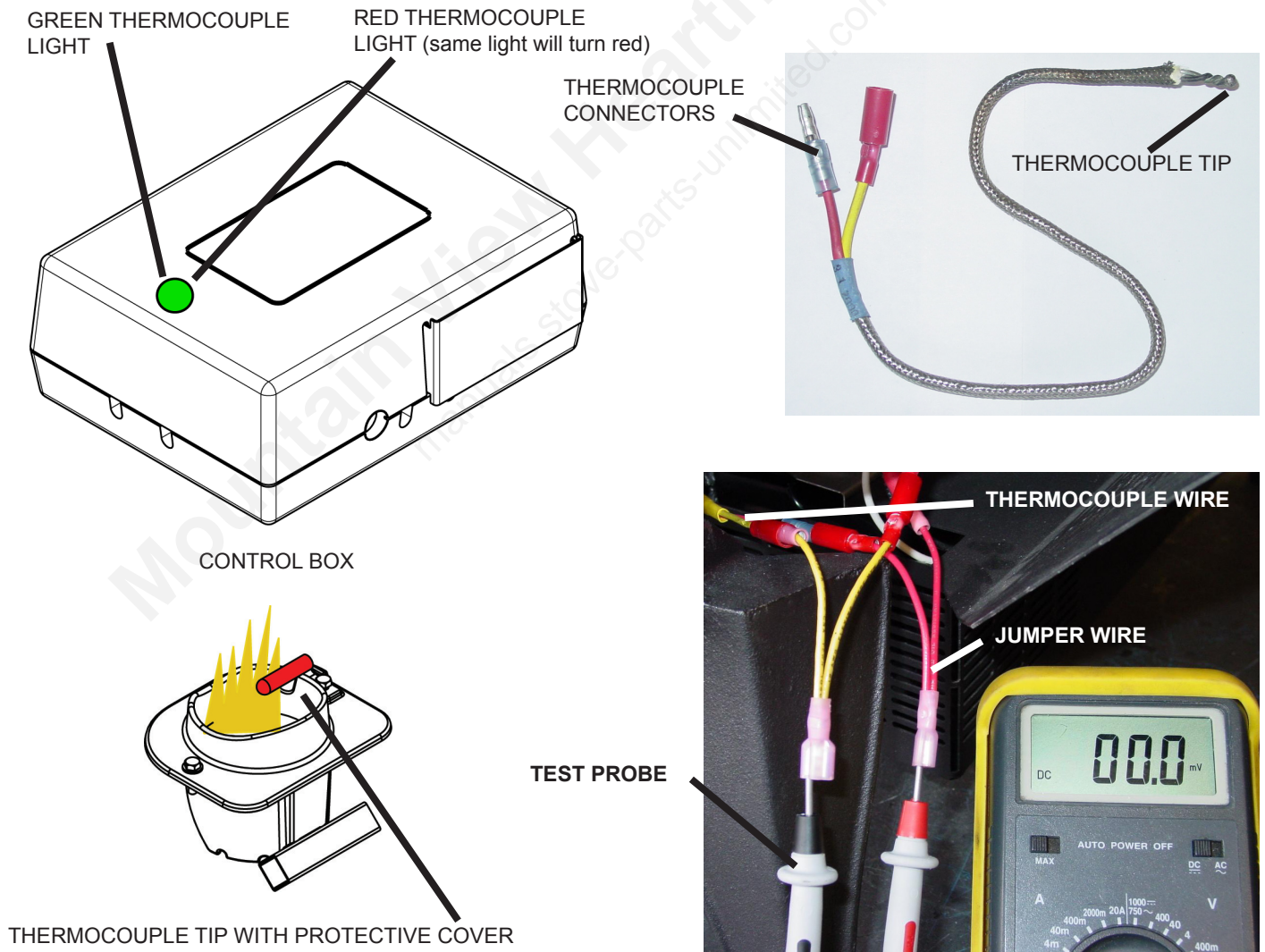

# ECO CHOICE PELLET STOVE SERVICE MANUAL

---

---

## FIREPOT AND EXHAUST SYSTEM TROUBLE-SHOOTING

THE FIREPOT IS MADE OF CAST STEEL AND IS DESIGNED WITH AIR INTAKE HOLES THAT SWIRL THE FIRE AND HELP TO REMOVE THE ASH CREATED FROM THE BURNING OF THE PELLET FUEL. THERE IS ALSO A SLOT OR AIR PASSAGE IN THE BOTTOM SIDE OF THE FIREPOT THAT ALLOWS HOT AIR FROM THE IGNITER TO LIGHT THE PELLET FUEL. DURING THE BURN CYCLE PROCESS IN THE FIREPOT, "CLINKER" MATERIAL WILL START TO BUILD-UP. (SEE \*FIGURE 1) THE RATE OF THIS BUILD-UP WILL DEPEND ON THE QUALITY OF THE PELLET FUEL BEING USED. OVER TIME THIS BUILD-UP OF CLINKER MATERIAL CAN OBSTRUCT THE AIR PASSAGES AND CAN CAUSE PROBLEMS WITH THE OPERATION OF THE FIREPOT. THIS CAN ALSO CAUSE THE FIREPOT CLEAN OUT DOOR TO BECOME HARD TO PULL IF THE FIREPOT IS NOT CLEANED ON A REGULAR BASIS.

THE FIREPOT IS JUST ONE COMPONENT OF THE TOTAL COMBUSTION SYSTEM. COMBUSTION AIR FLOWS INTO A ROUND OPENING LOCATED AT THE LOWER REAR OF THE UNIT. (SEE \*FIGURE 2) THIS AIR TRAVELS INTO THE ASHPAN AREA LOCATED BELOW THE BOTTOM OF THE FIREPOT. (SEE \*FIGURE 3) COMBUSTION AIR WILL FLOW THROUGH THE AIR OPENINGS IN THE FIREPOT AND IS THEN TRANSFORMED INTO EXHAUST GASES. THE EXHAUST GASES WILL FLOW FROM THE FIREPOT TO THE BAFFLE PLATES AND REAR FIREBOX AREA. (SEE \*FIGURE 4) THE EXHAUST WILL FLOW FROM THE BAFFLE AREA TO THE EXHAUST BLOWER HOUSING. (SEE \*FIGURE 5) THIS COMPLETES THE NEGATIVE PRESSURE OR VACUUM PORTION OF THE COMBUSTION SYSTEM. AFTER THE EXHAUST ENTERS THE EXHAUST BLOWER HOUSING IT IS THEN PUSHED OUT INTO THE VENT PIPE OR CHIMNEY PORTION OF THE EXHAUST SYSTEM. (SEE \*FIGURE 6)

IF ANY PART OF THE EXHAUST SYSTEM IS RESTRICTED, THE STOVE WILL BURN DIRTY WITH TALL LAZY FLAMES. THE STOVE MAY ALSO EXPERIENCE PROBLEMS WITH LIGHTING THE PELLET FUEL DUE TO THE REDUCED AIR FLOW THROUGH THE FIREPOT.

IF ANY PART OF THE EXHAUST SYSTEM IS BLOCKED, THE STOVE WILL NOT FEED BECAUSE THE VACUUM SWITCH WILL NOT ENGAGE. NORMALLY THE STOVE WILL HAVE BETWEEN .08 TO .16 INCHES OF WATER COLUMN IN THE FIREBOX WITH STOVE SET ON THE HIGH FEED RATE.

**\* FIGURE EXAMPLES ARE LOCATED ON THE NEXT PAGE \***

---

---

# ECO CHOICE PELLET STOVE SERVICE MANUAL

## FIREPOT AND EXHAUST SYSTEM TROUBLE-SHOOTING

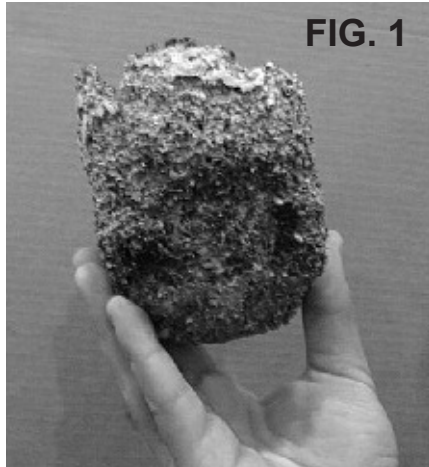

FIG. 1

EXAMPLE OF A VERY LARGE CLINKER



FIG. 2

COMBUSTION AIR INTAKE

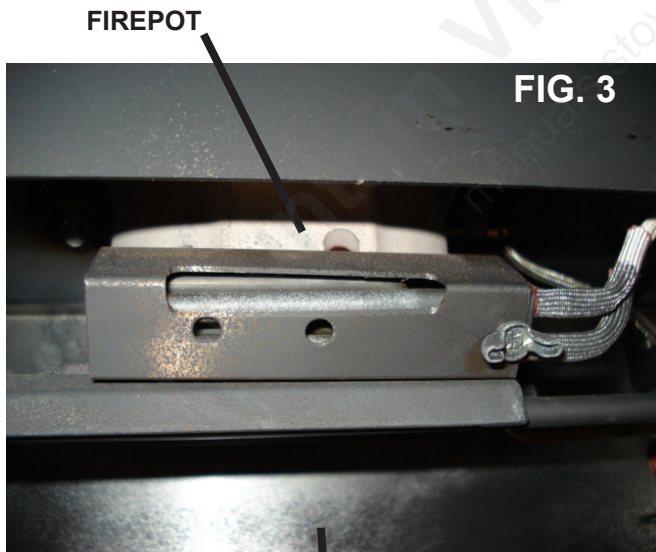

FIREPOT

FIG. 3

AIR INTAKE IN THE COMBUSTION CHAMBER  
(LOCATED UNDER ASH PAN)

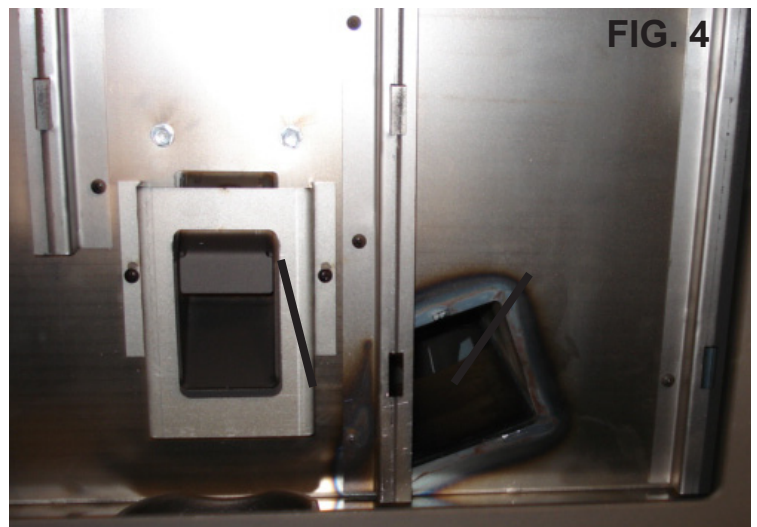
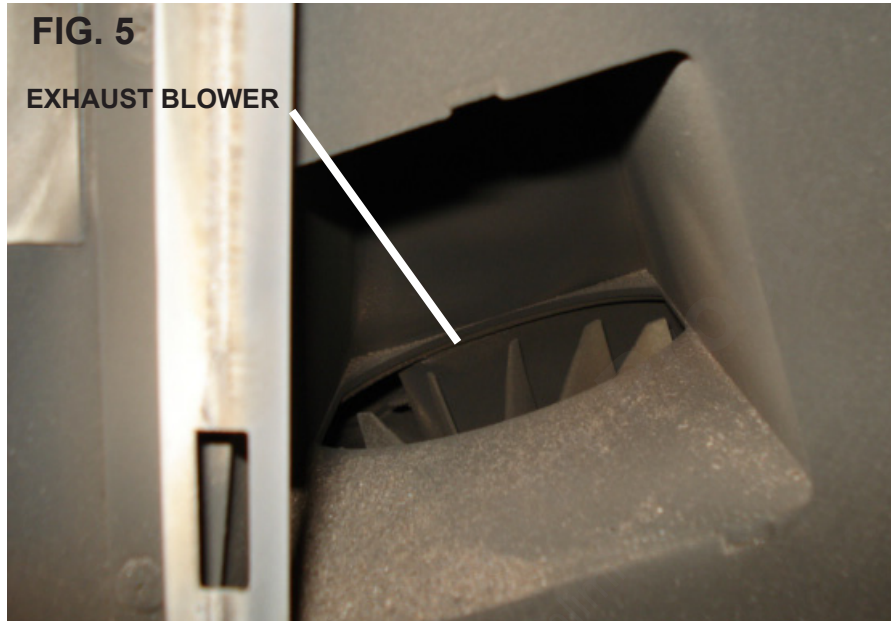

FIG. 4

FIREBOX AREA w/ BAFFLE PLATES REMOVED

FIREPOT AND EXHAUST SYSTEM TROUBLE-SHOOTING



EXHAUST BLOWER WITH  
THE BAFFLES REMOVED

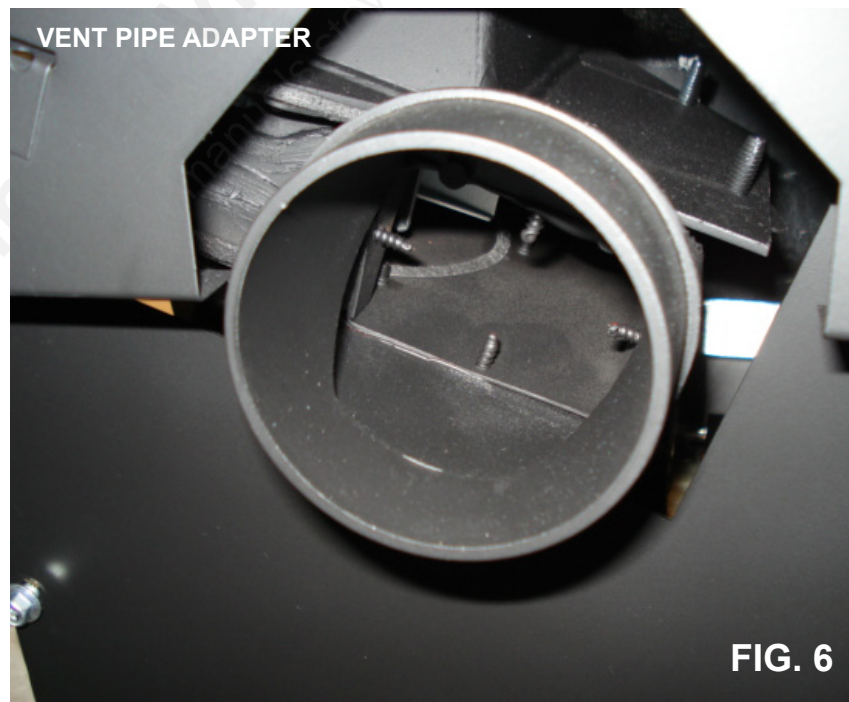

**FIG. 6**

# ECO CHOICE PELLET STOVE SERVICE MANUAL

## COMPLETE WIRE DIAGRAM

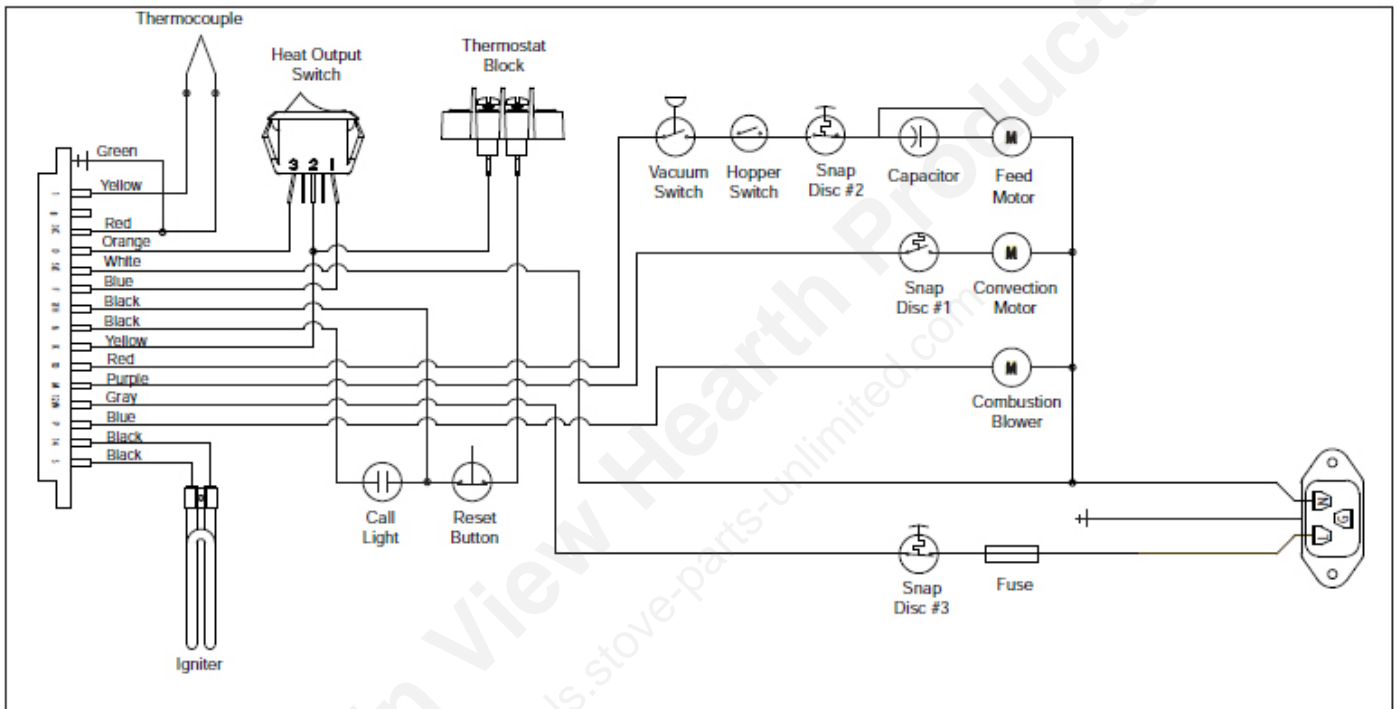

# ECO CHOICE PELLET STOVE SERVICE MANUAL

## GENERAL SPECIFICATIONS

	PS35	PS50
<b>WATTS:</b>		
EXHAUST BLOWER	29	55
CONVECTION BLOWER	60	150
IGNITER	380	380
FEED MOTOR	4	4
<b>AMPS:</b>		
EXHAUST BLOWER	.25	.48
CONVECTION BLOWER	.52	1.3
IGNITER	3.3	3.3
FEED MOTOR	.03	.03
<b>VOLTS ON THE HIGH FEED RATE SETTING (ALL COMPONENTS)</b>	115	115
<b>CONVECTION BLOWER VOLTS:</b>		
MEDIUM	94	85
LOW	80	75
<b>EXHAUST BLOWER VOLTS:</b>		
MEDIUM	109	104
LOW	103	91
<b>THERMOCOUPLE MILLIVOLTS:</b>	GREEN: 2.7 RED: 12.1	GREEN: 2.7 RED: 12.1
<b>THERMOSTAT CIRCUIT VOLTS:</b>	12 VAC	12 VAC
<b>BLOWER CFM:</b>		
EXHAUST	45	70
CONVECTION	150	220
<b>BTU:</b>	35,000	50,000
<b>POUNDS PER HOUR BURN RATE:</b>		
HIGH	4.1	5.8
MEDIUM	3.1	3.9
LOW	1.7	2.1
<b>FEED MOTOR "ON" TIMES:</b>		
HIGH	2.2	2.7
MEDIUM	1.6	1.9
LOW	.9	1.1
<b>FEED MOTOR RPM:</b>	2	2
<b>HOPPER CAPACITY:</b>	45	80
<b>SNAP DISCS:</b>		
#1 (CONVECTION)	F110-20	F110-20
#2 (OVER HEAT, SHUTS OFF FEED MOTOR, MANUAL RESET)	L175	L175
#3 (OVER HEAT, SHUTS OFF ALL POWER, MANUAL RESET)	L250	L250
<b>VACUUM: (COLD STOVE ON THE HIGH SETTING, FUEL IN HOPPER)</b>	.9 to .12 wc	.12 to .16 wc

**NOTE: Specifications are approximate.**

**NOTE:** Hearth & Home Technologies, manufacturer of this appliance, reserves the right to alter its products, their specifications and/or price without notice.



# TECH CHECK SHEET

## PELLET STOVES



PLEASE ANSWER ALL OF THE QUESTIONS BELOW IF YOU NEED TO CONTACT THE TECHNICAL SERVICES DEPARTMENT. THIS WILL HELP US TO IDENTIFY THE PROBLEM FASTER AND WILL SAVE YOU TIME.

WHAT IS WRONG WITH THE STOVE? \_\_\_\_\_

MODEL \_\_\_\_\_ SERIAL NUMBER \_\_\_\_\_

HOW IS IT INSTALLED? (VERTICAL OR HORIZONTAL) \_\_\_\_\_

HOW MANY VERTICAL FEET OF VENT? \_\_\_\_\_ HORIZONTAL? \_\_\_\_\_

HOW MANY ELBOWS ARE IN THE VENT SYSTEM? \_\_\_\_\_

WHAT SIZE IS THE EXHAUST PIPE? (3", 4", 6", OR OTHER) \_\_\_\_\_

WHAT IS THE ELEVATION OF THE HOME? \_\_\_\_\_

WHAT IS THE FEED ADJUSTMENT PLATE SET AT? \_\_\_\_\_

IS THE FEED SYSTEM OPERATING? \_\_\_\_\_

IS THERE POWER TO THE STOVE? \_\_\_\_\_

IS THERE FUEL IN THE HOPPER? \_\_\_\_\_

WILL THE THERMOSTAT CALL LIGHT COME ON? \_\_\_\_\_

IS THE IGNITER WORKING? \_\_\_\_\_ IS THE EXHAUST BLOWER WORKING? \_\_\_\_\_

ARE YOU REACHING THE FIRST STAGE OF IGNITION (GREEN LIGHT)? \_\_\_\_\_

ARE YOU REACHING THE SECOND STAGE OF IGNITION (RED LIGHT)? \_\_\_\_\_

IS THE CONVECTION BLOWER WORKING? \_\_\_\_\_

IS THERE AN OUTSIDE AIR KIT INSTALLED? \_\_\_\_\_

IS THE VENT SYSTEM CLEAN? \_\_\_\_\_

IS THE HOPPER FREE OF SAWDUST BUILD UP? \_\_\_\_\_

IS THE FIREPOT CLEAN? \_\_\_\_\_

**CUSTOMER SERVICE DEPARTMENT: PHONE--#800-926-4356**

# ECO CHOICE PELLET STOVE SERVICE MANUAL

## CLEANING & MAINTENANCE TIPS

**CAUTION: REMEMBER TO UNPLUG THE STOVE BEFORE PERFORMING ANY CLEANING OR MAINTENANCE ON THE STOVE.**

Cleaning or Inspection	Frequency		Daily	Weekly	Monthly	Yearly
Ash Drawer	Every 5 bags of fuel	OR		X		
Ash Removal from Firebox	Every 5 bags of fuel or more frequently depending on ash build-up	OR		X		
Blower, Exhaust	More frequently depending on the fuel type	OR				X
Blower, Convection	Every 25 bags or more frequently depending on operating environment.	OR			X	
Door Handle & Gasket Inspection	Prior to heating season	OR			X	
Exhaust Path, Drop Tube and Behind Baffles	Every 25 bags or more frequently depending on ash build-up	OR			X	
Firepot Cleaning Rod	Every 1 bag of fuel	OR	X			
Firepot with Clean-out Tool	Every 5 bags of fuel	OR		X		
Firebox - Prepare for Non-Burn Season	At end of heating season	OR				X
Glass	When clear view of firepot becomes obscure	OR		X		
Hopper	Every 50 bags of fuel	OR			X	
Top Vent Adapter	More frequently depending on ash build-up	OR				X
Venting System	Every 3 tons or more frequently depending on the fuel type	OR				X

**NOTICE:** These are recommendations. Clean more frequently if you encounter heavy build-up of ash at the recommended interval or you see soot coming from the vent. ***Not properly cleaning your appliance on a regular basis will void your warranty.***

# ECO CHOICE PELLET STOVE SERVICE MANUAL

---

---

## CLEANING & MAINTENANCE TIPS

### **FIREPOT:**

THE FIREPOT NEEDS TO BE CLEANED AS NEEDED. THE BUILD-UP OF CLINKER MATERIAL WILL DEPEND ON THE QUALITY OF THE FUEL BEING USED. IN SOME CASES, IT MAY BE NECESSARY TO CLEAN THE FIREPOT ON A DAILY BASIS.

FIREPOT CLEANING INVOLVES SIMPLY PULLING THE CLEANOUT ROD ON THE RIGHT SIDE OF THE STOVE. IF THE ROD IS HARD TO PULL, IT MAY BE NECESSARY TO USE THE SCRAPER OR SCREW DRIVER TO CHIP AWAY THE CARBON MATERIAL THAT HAS BUILT UP ON THE BOTTOM PLATE OF THE FIREPOT. ONCE THE DEBRIS IS CHIPPED AWAY, THE ROD WILL BE EASY TO PULL.

### **FIREBOX ASH:**

THE FIREBOX ASH SHOULD BE REMOVED AT THE SAME TIME THAT THE FIREPOT IS CLEANED. FREQUENT CLEANING OF THE ASH IN THE FIREBOX WILL HELP SLOW DOWN THE BUILD-UP OF ASH IN THE EXHAUST BLOWER AND VENT SYSTEM. REMEMBER TO DEPOSIT ASHES IN A NONCOMBUSTIBLE CONTAINER.

### **VENT / CHIMNEY SYSTEM:**

THIS NEEDS TO BE CLEANED AND INSPECTED AT LEAST ONCE A YEAR. IT MAY BE NECESSARY TO PERFORM MORE FREQUENT CLEANING IF THERE IS A LOT OF HORIZONTAL PIPE SECTIONS. ASH WILL BUILD UP MORE QUICKLY IN THE HORIZONTAL SECTIONS.

### **BLOWERS:**

THE BLOWERS MAY ONLY NEED TO BE CLEANED ONCE A YEAR. IF THE USE OF THE STOVE IS HEAVY, THEN IT MAY NEED TO BE DONE MORE FREQUENTLY. IF THE BLOWER IS GETTING NOISY, THEN THE FAN BLADES WILL NEED TO BE CLEANED.

# ECO CHOICE PELLET STOVE SERVICE MANUAL

---

---

Mountain View Hearth Products  
manuals.stove-parts-unlimited.com