

1989  
EDITION

# JAMESTOWN

---

Quality Pellet and Gas Appliances

## Pellet Stove Owner's Manual

Models J2000T and J2001T

Tested and Listed by Northwest Testing Laboratories, Inc.

To

UL 1482-83, UL 907-83, HUD UM-84 and OAR 814-23-900/909

Please read this entire manual before installation and use of this pellet fuel-burning room heater. Failure to follow these instructions could result in property damage, bodily injury or even death.

Contact local building or fire officials about restrictions and installation inspection requirements in your area.

Save this manual for future reference.

Hi-Teck Stoves, Inc.  
560 South Main Street  
Clearfield, Utah 84015

## CONTENTS

Introduction.....	1
Installation Instructions.....	2
Operating Instructions.....	14
Preferred Fuels.....	15
Maintenance.....	16
Operating Safety Features.....	17
Power Failure.....	17
Auger Care.....	17
Heat Exchange System Care.....	17
Electrical Schematic.....	18
Warranty and Warranty Registration Card.....	19
Trouble Shooting Guide.....	20
Very Low Burn Directions.....	21
Service Record.....	22

## GETTING TO KNOW YOUR NEW JAMESTOWN 2000T/2001T

### 1. SAFETY FIRST!

Your new JAMESTOWN pellet burning stove (or insert) was designed to provide many years of trouble free enjoyment in your home. It is up to you, however, to learn how to safely operate your new stove. Please start by paying particular attention to each of the following points:

- A. **SAFETY NOTICE:** IF THIS STOVE IS NOT PROPERLY INSTALLED, A HOUSE FIRE MAY RESULT. FOR YOUR SAFETY, FOLLOW THE INSTALLATION DIRECTIONS, CONTACT LOCAL BUILDING OR FIRE OFFICIALS ABOUT RESTRICTIONS AND INSTALLATION INSPECTION REQUIREMENTS IN YOUR AREA.
- B. Read the owner's manual thoroughly before attempting to install and/or burn your new stove. FAILURE TO FOLLOW INSTRUCTIONS MAY RESULT IN PROPERTY DAMAGE, BODILY INJURY, OR EVEN DEATH.
- C. Contact your local building officials for appropriate permits and information on possible restrictions or requirements on installation in your area.
- D. Burn pelletized bio-mass fuel which meets or exceeds APFI Standards only. Poor quality fuel will directly (and adversely) affect the efficiency and cleanliness of you new stove's operation. Your JAMESTOWN Dealer can help you make the proper fuel choice in your area.
- E. Always follow the lighting instructions in your owner's manual, short cuts of any kind can be dangerous!
- F. **ALWAYS** keep flammable liquids away from your new stove.
- G. Follow the installation and maintenance instructions outlined in your owner's manual exactly.
- H. **DISPOSAL OF ASHES:** When removing fly-ash accumulations from your stove, always place them in a metal container with a tight fitting lid. The closed container must be placed on a non-combustible surface well away from all combustible materials, pending final disposal. The ashes should be retained in the closed container until all cinders have thoroughly cooled.
- I. The power supply cord must be routed away from hot or sharp surfaces and objects and plugged into a grounded three prong outlet meeting all applicable local and National codes.
- J. Never place a combustible object on your stove top or trivet.
- K. **PLEASE NOTE: INATTENTION TO OR OTHER VIOLATION OF ANY OF THESE POINTS WILL CONSTITUTE SUFFICIENT CAUSE FOR THE VOIDING OF YOUR WARRANTY!**

## 2. INSTALLATION

Your new JAMESTOWN 2000T Free Standing Pellet Stove or 2001T Zero Clearance Fireplace insert must be installed correctly to assure safe and efficient operation.

As HI-TECK STOVES, INC. has no control over the installation or operation of your stove (or insert), HI-TECK STOVES, INC. grants no warranty, implied or stated, for the installation or maintenance of your new stove (or insert), and assumes no responsibility for any consequential damage. It is doubly important, then, that you exercise prudent judgement in deciding whether to install yourself or contract for installation with your dealer (or other professional installer your dealer recommends.

A. Clearances, 2000T Free Standing stove: your new stove must be installed on a non-combustible floor pad of at least 3/8" millboard (or equivalent) or a masonry hearth. The hearth or floor pad must extend a minimum of 8" from the front of the stove, 3" to a wall on either side of the stove (8" if wall is further than 8"), and 2" from the rear of the stove. Please refer to drawing A.

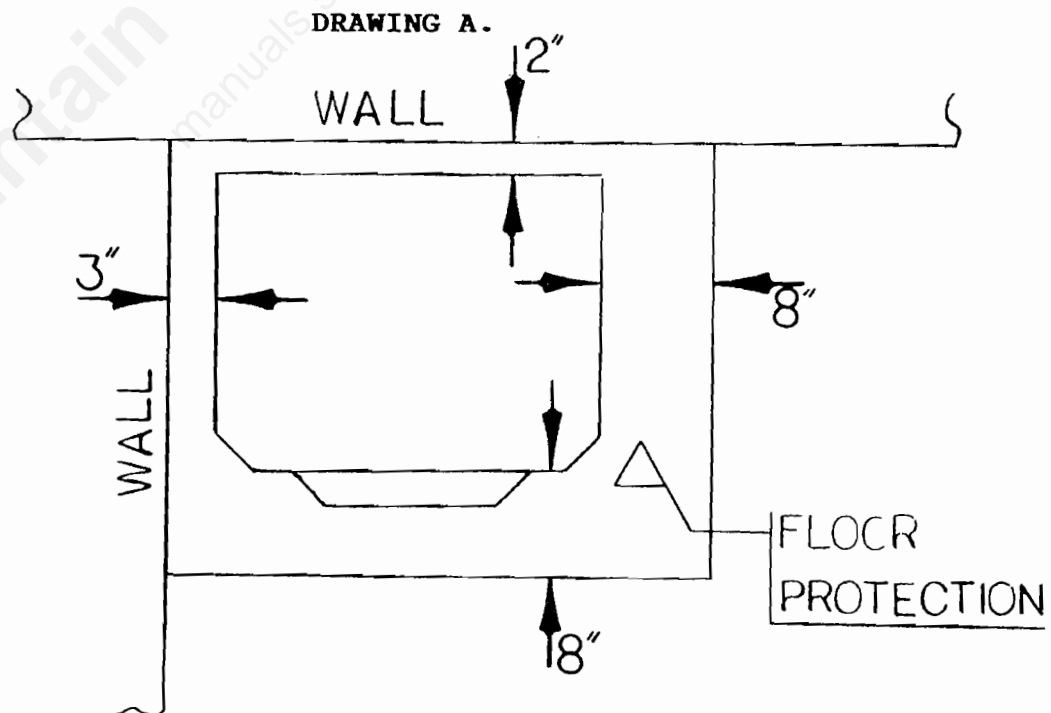

If you are installing your stove into an alcove, please refer to drawing B for minimum clearances.

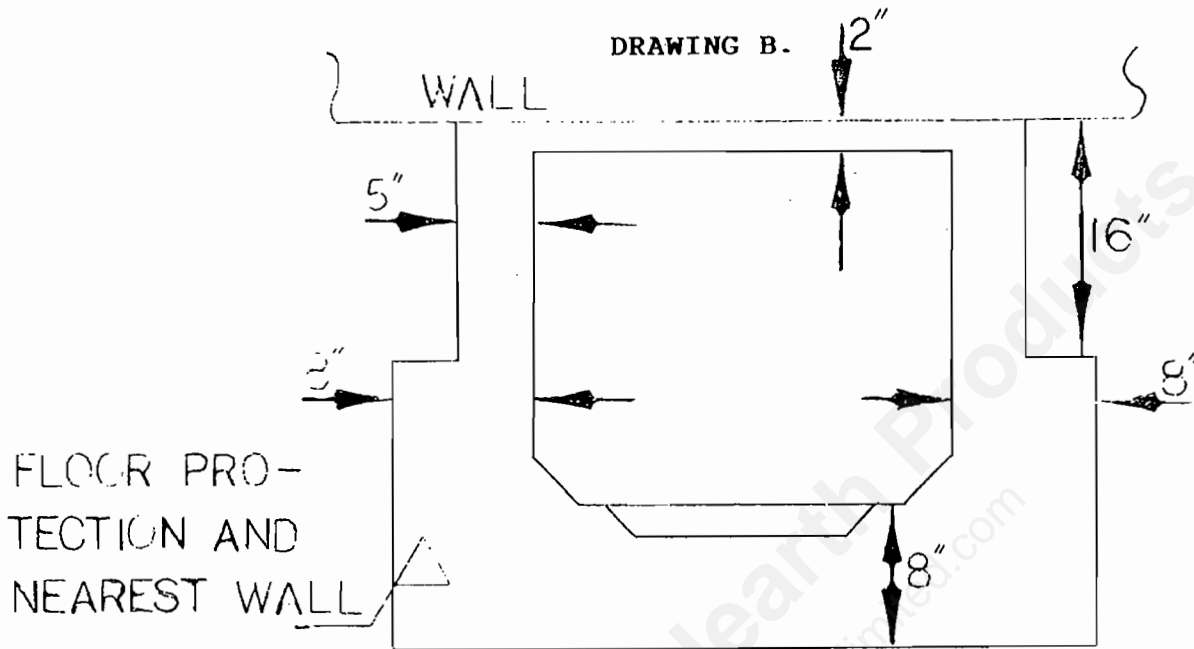

Vertical Clearances: The minimum distance from the top of your stove to the bottom of a shelf, mantel, or any combustible object above the stove is 18" (drawing C).

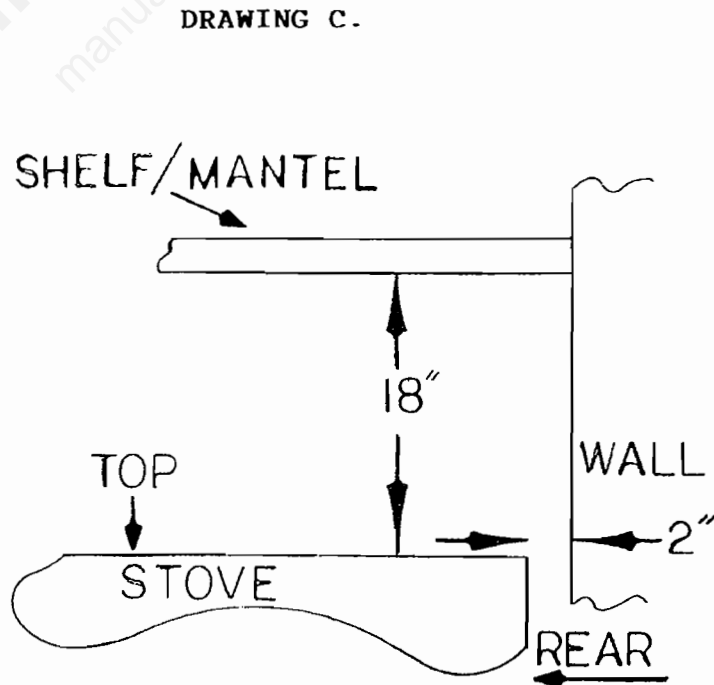

Corner Installations: If you are installing your stove in a corner, please refer to Drawing D.

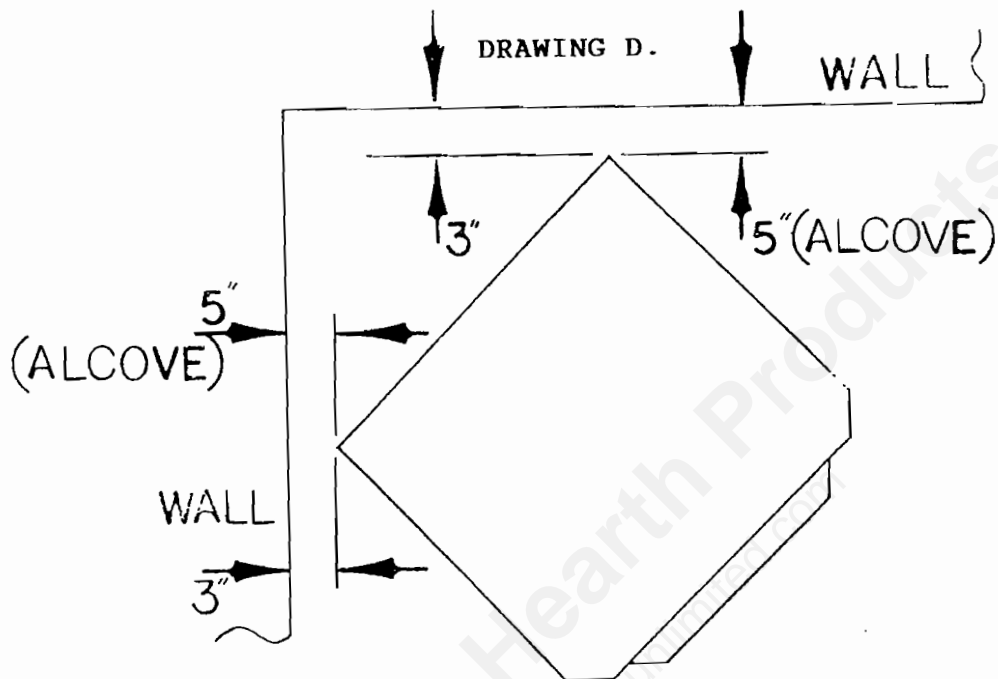

B. Clearances, 2001T Zero Clearance Fireplace Insert: Minimum clearances to combustibles affect only the portion of your insert which protrudes into the room from the point of shroud attachment to the insert. The installation must include an approved non-combustible floor protection pad of at least 3/8" millboard (or equivalent) or a masonry hearth which extends a minimum of 8" from the front of the insert (where the door gasket seals when closed) and 8" from either side. Additionally, the minimum distance from the top of the insert (trivet area) to the bottom of a mantel, shelf, or other combustible is 18". Please refer to drawings D1 and D2.

**Critical note for all installations:** The 3/8" millboard (or equivalent) floor protection pad you select (unless you are installing on a masonry hearth) must be safety approved.

DRAWING D1.

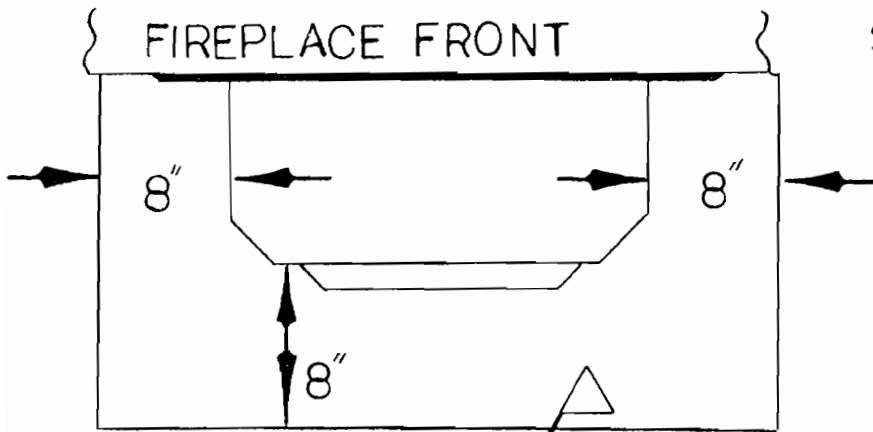

FLOOR PROTECTION  
AND NEAREST COMBUSTIBLE

DRAWING D2.

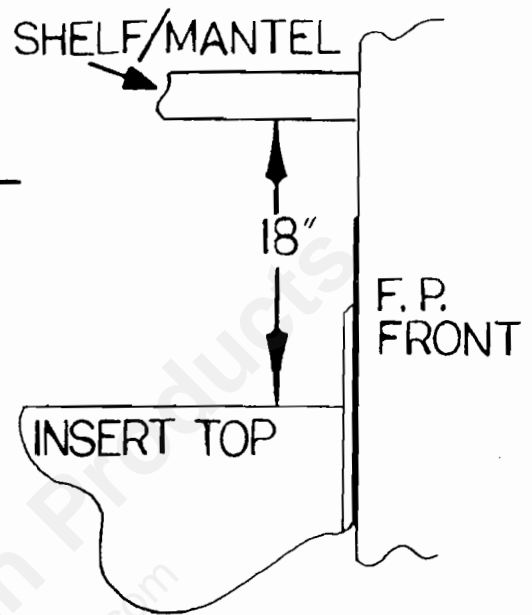

E. Venting the 2000T Free Standing Stove: The most typical installation is parallel to and against an outside wall. For this installation, the simplest and least expensive approach is the Jamestown model number J2020T Standard Installation Kit, available from your Jamestown Dealer (please refer to Drawing E1 and follow the directions supplied with the kit).

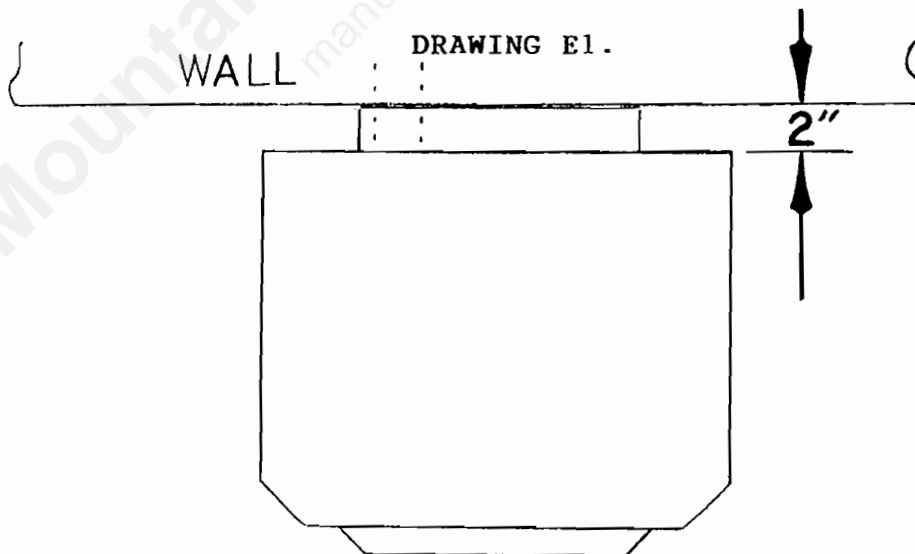

If you are installing your new stove without the J2020T Standard Installation Kit, or installing other than parallel to and against an outside wall, you will need to closely review the following directions and acquire the proper materials outlined for your installation (your Jamestown Dealer can help you with the necessary materials): "PL" Type pellet vent may be installed directly through a combustible wall, ceiling, or roof, using a listed wall thimble, fire stop, or roof flashing. Clearance using a listed wall thimble will be a minimum of 1½" to any combustible; using a fire stop or or roof flashing requires 3" minimum clearance to any combustible. Routing the exhaust through the roof may be done in a conventional manner, or through an outside wall below the roof line, with three restrictions: 1. The exit terminal Must be located not less than 60" from any opening through which combustion products could enter the building (i.e. doors, windows, vents ), nor less than 24" from an adjacent building and not less than 7' above grade when located adjacent to public walkways. It must be so arranged that flue gasses are not directed so as to jeopardize people, overheat combustible structures, or enter a building. 2. For horizontal venting, the exhaust pipe must be terminated by a listed end cap or 45 degree elbow with a rodent screen cap that prevents rain or wind directly entering the exhaust pipe. For termination above the roof line, a listed rain cap must be used. 3. Each "PL" Type joint must be completely sealed using High Temperature Silicone ("RTV"), three sheet metal screws, and High Temperature Foil Tape.

Tools you will need include: saw(s), screw-drivers, 1/8" drill, 5/8" hex head socket or driver, tape measure, gloves, eye protection, and (for some installations) a sturdy ladder.

## MATERIALS NECESSARY FOR:

1. Horizontal venting, parallel to and against an outside wall
  - a. 7" O.D. "PL" Type wall thimble
  - b. 24" length of 3" "PL" Type pipe
  - c. 3" "PL" Type end cap  
(or 45 degree elbow and rodent screen)
  - d. 12" length of 5/8" flexible metal hose and rodent screen
  - e. 3 oz. High Temperature Silicone Sealant (RTV)
  - f. High Temperature Foil Tape
  - g. 9 ea. 5/32" X 1/2" sheet metal or self-tapping screws
  
2. Horizontal venting, corner installation, outside wall, ADD TO LIST ONE:
  - h. 3" 45 degree "PL" Type elbow
  - i. Hose (d) length must be increased to 24"
  - j. additional screws (g)
  
3. Venting vertically outside roof line, parallel to and against an outside wall, ADD TO LIST ONE:\*\*
  - c. Subtract end cap
  - k. 3" "PL" Type Tee
  - l. 3" to 4" "PL" Type increaser
  - m. 4" "PL" Type rain cap
  - n. 4" "PL" Type roof flashing
  - o. 4" "PL" Type pipe (appropriate lengths)
  - p. 4" "PL" Type wall brackets (one for each 5' of rise)
  - q. Additional screws (g), RTV (e), and tape (f)
  
4. Venting vertically outside roof line, corner installation, outside wall:
  - All materials above listed except end cap (c)

**\*\*OR J2020T STANDARD INSTALLATION KIT**

5. Venting vertically inside roof line:

- Items d, e, f, g, k, l, m, n, o, q
- r. 4" "PL" Type roof flashing

6. Venting the J2001T Fireplace Insert:

It is **strongly recommended** that you contract with a professional installer, as there must be a **positive seal** above the flue of your fireplace, a **complete re-line** to the top of your chimney, and provision for a constant supply of fresh air available to the draft induction system during normal operation.

**This is a safety issue and must not be taken lightly.**

7. Installation notes

-The J2020T Standard Installation Kit provides outside air for combustion and requires only one hole to be cut in your wall (free standing stove only). Complete instructions and all the materials you will need for a simple "thru-wall" installation are in each kit.

-It is important that the materials above outlined be used exactly as specified; substitutions or shortcuts may be neither listed nor safe.

-Installations requiring more than 10 feet of exhaust or more than one 90 degree exhaust angle: the exhaust pipe diameter should be increased to 4".

-The floor protection pad referred to throughout this manual must be safety listed.

-If you elect not to use self-tapping screws in your installation, you will not need the 5/16" hex driver referenced in the last paragraph of page six.

-Care must be taken to plug the power cord into a grounded three prong outlet, **after** your stove or insert is in place (minimizing the possibility of electrical shock).

-Any installation incorporating an existing chimney must include a re-lining of the existing chimney.

F. Installation Drawings and Directions:

1. Horizontal venting, parallel to and against an outside wall without J2020T Standard Installation Kit

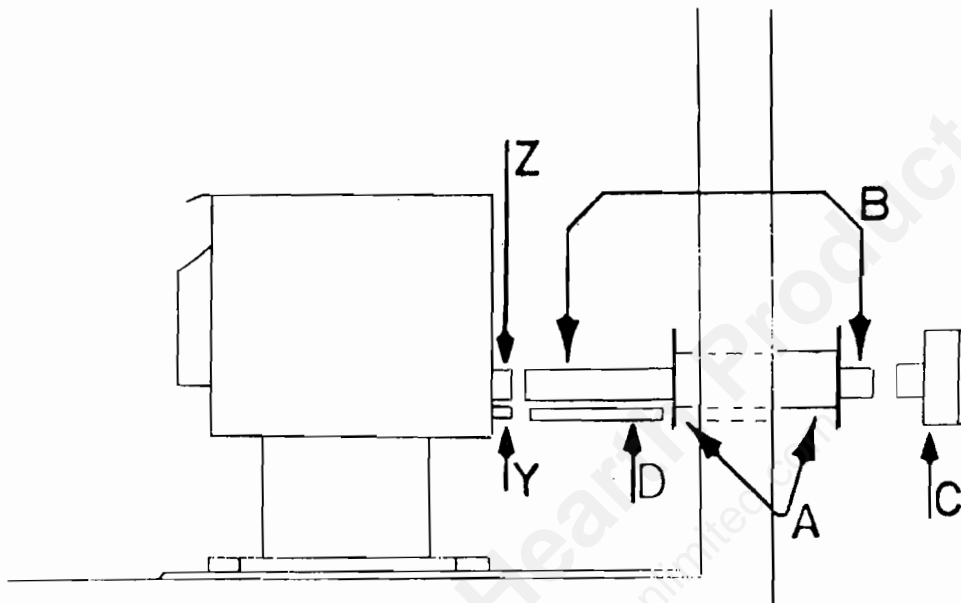

**Step One**-Determine Locations for and cut holes in wall for thimble (a) and 1 5/8" intake air tube (d). Center of thimble hole will be 15 5/16" above top surface of floor protection and 7 3/4" to the left of center.

**Step Two**-Install wall thimble (a).

**Step Three**-Apply 1/8" bead of RTV (e) around circumference of exhaust stub (z) 1/2" toward stove from end of stub, slide 3" pipe (b) over stub to rear cover of stove and secure with three screws (g).

**Step Four**-Apply 1/4" bead of RTV (e) around circumference of combustion air intake (y) near end of stub and slide 1 5/8" air intake tube (d) over stub to rear cover of stove.

**Step Five**-Position stove into alignment with holes in wall and gently slide stove up to wall, watching to be sure pipe (b) and tube (d) enter thimble and air intake hole properly.

**Step Six**-Affix end cap (or elbow and rodent screen, c), using RTV (e), screws (g), and High Temperature Foil Tape (f).

**Step Seven**-Trim intake air tube approximately flush with outside wall and secure rodent screen.

2. Horizontal venting, corner installation,  
outside wall

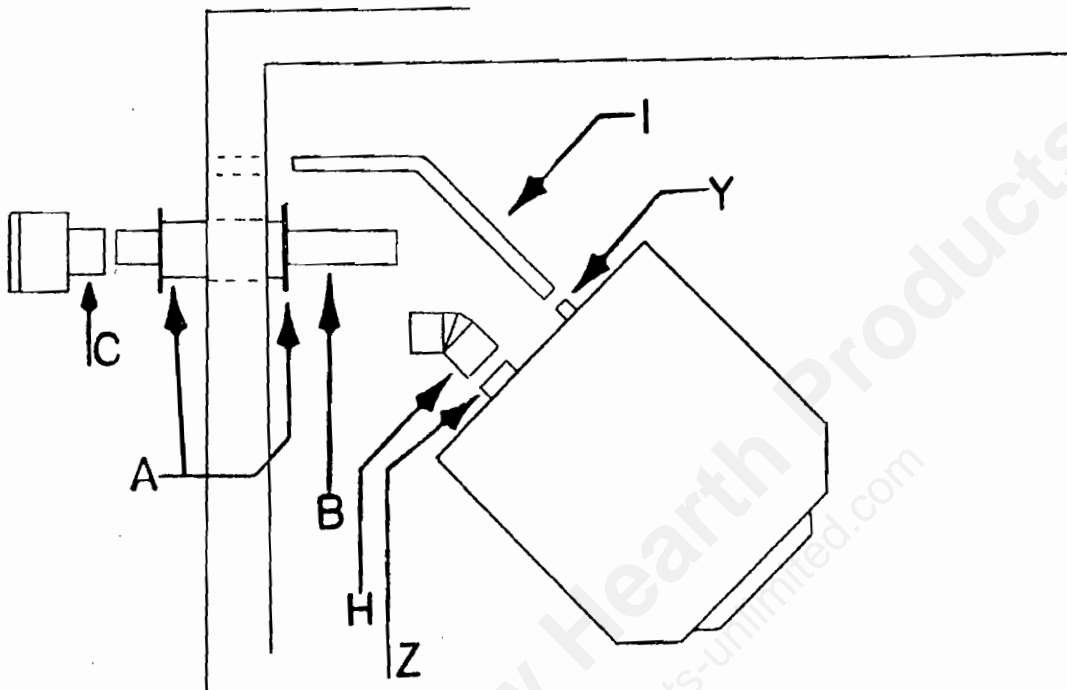

**Step One**-Determine locations for and cut holes in wall for thimble (a) and 1 5/8" intake air tube (d). Center of thimble hole will be 15 5/16" above top surface of floor protection.

**Step Two**-Install wall thimble (a).

**Step Three**-Apply 1/8" bead of RTV (e) around circumference exhaust stub (z) 1/2" toward stove from end of stub, slide elbow (h) over stub to rear cover of stove (careful to watch for proper orientation) and secure with three screws (g). Secure pipe (b) to elbow (h) using RTV (e), screws (g), and tape (f).

**Step Four**-Apply 1/4" bead of RTV (e) around circumference of combustion air intake (y) near end of stub and slide 1 5/8" air intake tube (d) over stub to rear cover of stove.

**Step Five**-Position stove into alignment with holes in wall and gently slide stove up to wall, watching to be sure pipe (b) and tube (d) enter thimble and air intake hole properly.

**Step Six**-Affix end cap (or elbow and rodent screen, c), using RTV (e), screws (j), and tape (f).

**Step Seven**-Trim intake tube approximately flush with outside wall and secure rodent screen.



4. Venting vertically outside roof line,  
corner installation, outside wall

**Step one**—Follow Steps One through Five and step number seven outlined in "corner installation" on page ten.

**Step Two**—Follow Steps Two through Seven outlined in "venting vertically outside roof line" on page eleven.

5. Venting vertically inside roof line

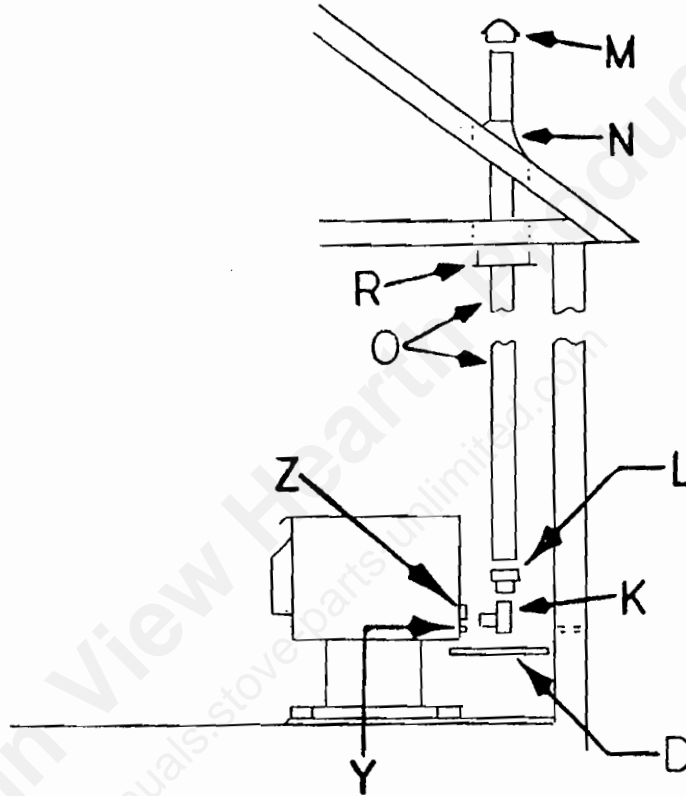

**Step One**—Apply 1/8" bead of RTV (e) around circumference of exhaust stub (z) 1/2" toward stove from end of stub, slide Tee (k) over stub to rear cover of stove (being sure to orient Tee cleanout opening downward) and secure with three screws (g).

**Step two**—Secure increaser (l) to Tee (k), using RTV (e), screws (g), and tape (f).

**Step Three**—Cut (10" minimum diameter) holes in appropriate locations in ceiling and roof and install firestop (r) and roof flashing (n).

**Step Four**—Secure appropriate lengths of pipe (o) from increaser up through firestop and (to a minimum of 24" above) roof flashing, using RTV (e), screws (g), and tape (f).

**Step Five**—Secure rain cap (m), using RTV (e), screws (g), and tape (f).

**Step Six**—Cut 1 5/8" hole in closest exterior wall and secure the appropriate length of metal hose (d) as described in Steps Four and Seven on page nine.

JAMESTOWN T SERIES CONTROL PANEL

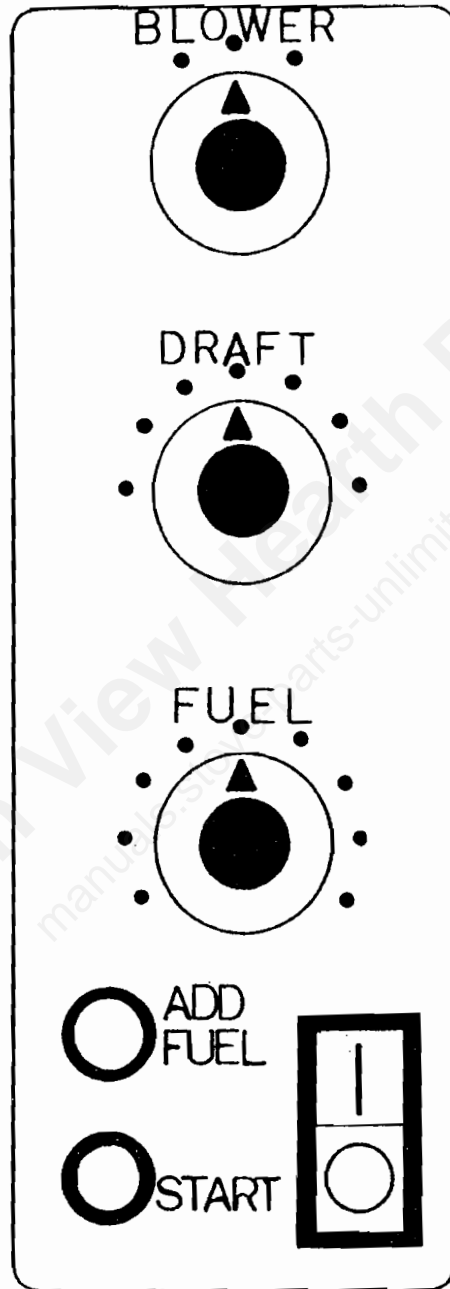

### 3. OPERATING YOUR NEW J2000T FREE STANDING STOVE OR J2001T ZERO CLEARANCE FIREPLACE INSERT

A. Principle of operation: Pellet fuel is delivered from the hopper to the fire pot via an auger and gravity system. When the fuel rate is set properly to augment the draft rate, an extremely clean fire burns, driving a high efficiency heat exchange system. The fuel delivery, draft, and heat exchange rates are selectable.

B. Control panel operation:

- BLOWER RATE CONTROL** - increases/decreases convection blower (heat exchanger) rate
- DRAFT RATE CONTROL** - increases/decreases draft induction rate
- FUEL FEED RATE CONTROL**- increases/decreases pellet feed rate
- ADD FUEL INDICATOR** - indicates need for additional fuel in hopper when illuminated
- START SWITCH** - activates 30 minute warm up cycle
- ON/OFF SWITCH** - permits operation in ON position, shuts burn down in OFF position

C. Lighting instructions: There are many fire-starter products available, normally composed of compressed wax blocks or wood shavings; these products are designed to safely and efficiently start your fire and it is highly recommended you speak with your dealer for advice on which will best work in your area. **Never** attempt to use flammable liquids to start or "freshen up" a fire in your JAMESTOWN stove or insert. 1.) Fill hopper with pellets. Press START button and activate ON/OFF switch to ON. Turn FUEL control knob to maximum and watch for pellets to begin dropping into the fire pot. After approximately 20 pellets have dropped, activate the ON/OFF switch to OFF (the fans will continue to run but the pellet feeding will stop). 2.) Add the prescribed amount of your fire starter and a few more pellets. Turn DRAFT control to maximum and BLOWER control to medium. Light the fire starter, letting it burn to ignite the pellets around it. This may take some time, depending on the fire starter. 3.) Slowly close the door (if this starts to put your fire out, open the door a little). It may be necessary to add a little more fire starter. As soon as the fire will burn with the door closed, latch the door securely for continued operation. 4.) Turn the ON/OFF switch to it's ON position and the FUEL control to it's "9:00 O'Clock" position (if pellets begin to build up in the fire pot, you can turn the ON/OFF switch to it's OFF position long enough for the fire to build).

D. SETTING THE HIGH BURN: Allow the system to come up to operating temperature (about 15 minutes). At the end of that time, your fire may be burning efficiently on the current settings (a bright yellow fire with a few small sparks ("fly ash") being emitted from the firepot, but no large chunks of red-hot pellets being emitted). If the fire is "orangeish" or "lazy" and is not emitting a few small sparks, your FUEL feed rate is set too high and will need to be adjusted downward. If the fire is bright yellow and emitting large chunks of red-hot pellets, your FUEL rate is set too low and will need to be adjusted upward. Be sure to give the system time to stabilize after each adjustment (about 10 minutes). After you have achieved a "clean" high burn, make a note of the settings for future reference.

E. SETTING THE LOW BURN: Turn the DRAFT and FUEL control knobs to their "1:00 O'Clock" positions. Adjusting the FUEL control knob up or down as necessary, find the position which gives you a "clean" low burn (a clean low burn will provide a yellow fire, emitting a few small sparks, and will "cycle" from a smaller to a larger flame... it may emit a few small chunks of red-hot pellets). Make a note of the settings for future reference. Should you desire more settings, follow the same procedure, starting with the re-setting of the DRAFT control knob.

F. BURN NOTES: 1.) A clean fire will burn with a small amount of fly ash floating in the firebox and will not produce visible smoke or emit large chunks of burning pellets. Orange fire is not clean fire; yellow fire is. 2.) You are likely to find that you will not be able to set the DRAFT or FUEL controls at their extreme settings and maintain a clean fire. This is because your new stove was designed to burn different sizes and densities of pellet fuel at different altitudes in differing types of installations and, therefore, incorporates very wide control ranges.

F. Prolonged operation: Your new JAMESTOWN stove will operate indefinitely (between cleanings) at any "clean fire" setting, given that it has fuel in the hopper, 110VAC (standard wall receptacle) power, and proper airflow (clean exhaust channels, clean induction fan impeller, and no obstructions in the air intake area).

G. Adjustments: 1.) Be certain you have the blower rate set high enough to properly drive the heat exchange system. If you do not, the stove will overheat and shut itself down. 2.) It is necessary that you allow sufficient time to stay near your new stove when adjusting the controls in order that you leave it set with a "clean" fire burning.

H. Shutting the stove down: Set the ON/OFF switch to the OFF position. The draft induction fan and convection blower will continue to run until the fire has gone out and the stove cools to about 90 degrees.

4. PREFERRED FUELS: Be certain to burn only those pellet brands meeting or exceeding APFI-88 standards.

## 5. MAINTENANCE

**Please note:** all maintenance should be performed with the stove off and in a cool condition.

### A. Semi-weekly maintenance:

Glass- The accumulations on the inside of the door glass should be gray (fly ash) and may wipe off with a dry paper towel (depending on burn size and efficiency, and whether an optional thermostat control unit is in use). In the event it does not, dip a wet paper towel in some fly ash, scrub the inside of the glass, and dry with a fresh paper towel.

Heat exchange tubes- With the door closed, pull the small rod tip just above the door toward you. You will see accumulated fly ash drop into the firebox area. Pushing the rod back in, you may see more. Continue to pull it out and push it back in until you see no more fly ash dropping.

Firebox area- There will be a certain amount of fly ash accumulation in this area. It is most convenient to remove by using a small whisk broom, brushing the accumulation into the area around the fire pot, through which it will drop into the ash pan.

Ash pan- Remove by turning the knob at the front of the pan counter-clockwise and pull the pan toward you (see Safety First!, page one). When replacing the ash pan, be certain it seals properly while turning the knob clockwise (do not force).

Fire pot- Inspect for accumulations of burn by-products and scrape off (into the removed ash pan). Be certain to inspect for accumulations obstructing the air inlet holes around the bottom of the fire pot.

Manifold- This is the "empty box" on which the fire pot rests. If it has accumulated ash, it is easiest to remove with a vacuum cleaner.

Finish- Once the paint on your new stove or insert has "cured", occasional dusting and washing with a mild soap and warm water is all that is recommended. Some of the available JAMESTOWN T Series trim is gold, some is brass, and it is all delicate. Do not use abrasives of any kind to clean trim or finish.

### B. Semi-annual (every 90 operating days) maintenance:

Seals and gaskets- If, at any time, the fire in your stove or insert tends to "lick" toward the glass more than normal, or if you begin to notice a change in the settings you need to select to achieve a given clean burn rate, you may have a loose or wearing gasket or seal. Inspect the gaskets on the door and ash pan at least twice a season and repair or replace as needed (your Dealer will be able to help you with this).

Ash pockets- Remove the firebrick on both sides of the firebox by removing the screw in the bracket at the top of each firebrick. Using a bottle brush, clean all surfaces you can reach above the fly ash accumulation in each cavity. Insert the bottle brush between the top of the firebox and the heat exchange tubes and clean the cavity there on each side.

### C. Annual Maintenance:

(You will find your Dealer is well equipped and proficient in this service)

Draft impeller- Remove all firebrick by removing the screws at the top of each. Remove the inspection plate just below and to the left of the pellet feed chute, exposing the draft impeller. Inspect and, if necessary, clean with a bottle brush. Replace inspection plate (being careful to attain a flush fit) and all firebrick.

Exhaust system- Inspect and clean as necessary, being certain to reassemble all components with secure and airtight seals.

Convection blower- Inspect and clean squirrel cage as necessary.

### 6. OPERATING SAFETY FEATURES

Your new JAMESTOWN stove or insert was designed with safety in mind. These include:

- A. Full System fuse
- B. Thermal Protection on all motors
- C. High Temperature Limit Switch
- D. Low Temperature Limit Switch
- E. Voltage Surge Suppression

**Please note:** The JAMESTOWN T Series was designed with simplicity of circuitry (no computers) in mind. This design is sturdy and will operate efficiently for many years. It is strongly recommended, however, that only qualified personnel perform analytical, repair, or modification work unless otherwise specified.

### 7. POWER FAILURE

In the event of a power outage or other interruption of the supply of power to your stove or insert, the entire system will shut down, possibly causing a small amount of smoke to escape from the stove temporarily. If the power comes back on within a few minutes, the fire may re-ignite and burn normally. If the power is off longer, you will arrive to find the pellets continued to feed into the firepot until the system had cooled down, and is no cause for alarm.

### 8. AUGER CARE

The auger and auger motor in your new stove (or insert) are the highest quality available. The entire apparatus is precision ground and assembled (this will promote self-cleaning and minimize "hard pellet" jams). It is very important, however, that foreign objects of any kind are not allowed into the fuel hopper. In the event something does "jam" the auger system, empty all pellets, and unplug the stove or insert. Remove the rear cover of the stove (for inserts, remove from the fireplace) and rotate the auger motor back and forth until the jam clears. If the jam is extremely stubborn, remove the auger assembly (your Dealer may have to help you with this). Clear the obstruction and reassemble.

## ELECTRICAL SCHEMATIC

**NOTE:** The power supply cord must be routed away from hot or sharp surfaces and objects and plugged into a grounded three prong 117VAC outlet meeting all applicable local and National codes.

\*BROWN, RED, BLACK, BLUE ARE DIRECTLY CONNECTED, ORANGE AND WHITE ARE "NO CONNECT" ON ALL STANDARD UNITS. ALL ARE CONNECTED THROUGH THE THERMOSTAT CONTROL UNIT OPTION WHEN INSTALLED.

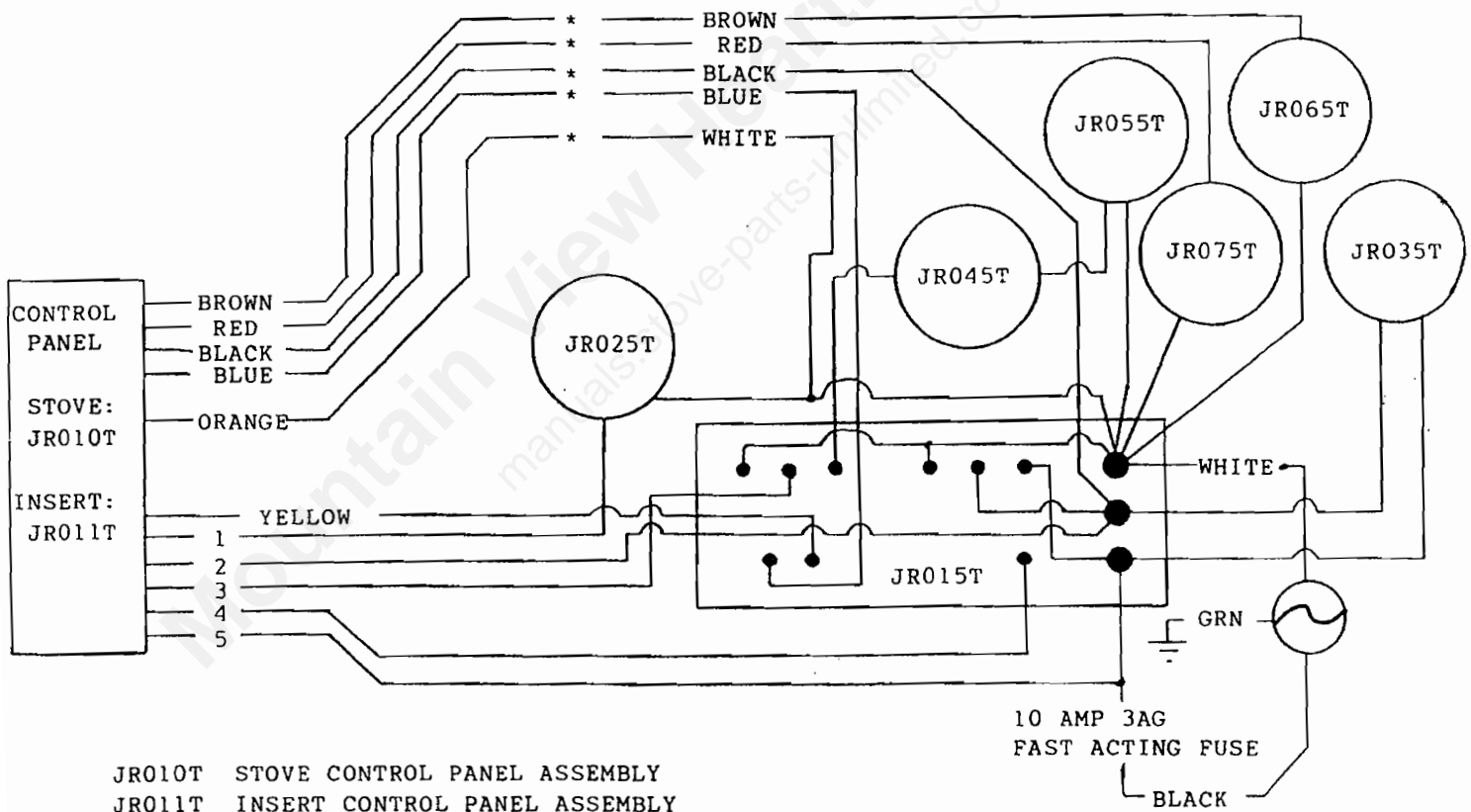

- JR010T STOVE CONTROL PANEL ASSEMBLY
- JR011T INSERT CONTROL PANEL ASSEMBLY
- JR015T JUNCTION PANEL ASSEMBLY
- JR025T LOW FUEL DETECTION SWITCH
- JR035T MINIMUM TEMPERATURE SENSOR
- JR045T MAXIMUM TEMPERATURE SENSOR
- JR055T AUGER MOTOR
- JR065T CONVECTION BLOWER ASSEMBLY
- JR075T INDUCTION FAN ASSEMBLY

**LIMITED 5 YEAR WARRANTY**

HI-TECK STOVES, INC. warrants this J2000T/J2001T pellet burning appliance against defects in material or workmanship for a period of five (5) years from the original date of purchase for use, and agrees to repair or, at our option, replace any defective unit without charge for parts and, for the first year, labor. Service at an installation site further than twenty (20) miles from the nearest service location or dealer may result in a mileage charge. Registration of the warranty card within thirty (30) days of purchase for use and proof of purchase will be required.

This warranty does not cover damage resulting from accident, misuse or abuse, any modification or alteration including attaching the unit to other than the recommended receptacle or voltage, nor does it cover firebrick, glass, gaskets, plating, or paint. Additionally, this warranty does not cover any incidental or consequential damages, nor transportation to the factory, if necessary, for repairs.

THIS WARRANTY IS VOID WHEN SERVICE OR REPAIRS ARE PERFORMED BY A NON-AUTHORIZED SERVICE LOCATION OR DEALER.

NO OTHER WARRANTY, WRITTEN OR VERBAL, IS AUTHORIZED BY HI-TECK STOVES, INC. THIS WARRANTY APPLIES FOR THE ORIGINAL PURCHASER AND IN THE UNITED STATES ONLY.

To protect your rights under this warranty, be certain to:

- A. Read and follow the instructions in your owner's manual thoroughly and exactly.
- B. Complete and mail the Warranty Registration card **WITHIN THIRTY DAYS OF PURCHASE**
- C. Do Not attempt to service or modify your new stove yourself. Your dealer is your closest authorized service agent.

This warranty gives you specific legal rights, and you may also have other rights which vary from state to state. Some states do not allow the exclusion or limitation of incidental or consequential damages, so the above exclusion may not apply to you.

**SERIAL NUMBER** \_\_\_\_\_ **DATE OF PURCHASE** \_\_\_\_\_

**DEALER NAME AND PHONE #** \_\_\_\_\_

**DATE WARRANTY REGISTRATION CARD MAILED** \_\_\_\_\_

## TROUBLE SHOOTING GUIDE

CONDITION: Flame appears smoky and orange or "licks" toward door or glass more than usual

CHECK FOR: Fuel rate setting too high for setting of draft induction fan; tight seal on door, ash pan, and door glass gaskets; obstructions in air intake area or exhaust system; accumulation of fly ash in ash pockets or on draft induction impeller

CONDITION: "Clinkers" are developing in fire pot

CHECK FOR: Inferior quality pellet fuel or fire starter product; infrequent cleaning; fuel rate too high

CONDITION: On low burn setting, flame sporadically dies out

CHECK FOR: Fuel rate setting too low for setting of draft induction fan

CONDITION: Fuel stops feeding and fire eventually extinguishes for lack of fuel

CHECK FOR: Low fuel; jammed auger\*; convection blower speed set too low to dissipate heat generated by high burn rate

CONDITION: Fuel is very low, but low fuel indicator does not illuminate

CHECK FOR: Pellets or foreign material wedged between low fuel actuator plate and hopper wall; indicator lamp needs replacement

CONDITION: No (or less than normal) heat is being delivered through the primary heat exchange system (the ten tubes just above the door)

CHECK FOR: Fly ash accumulation on outside of tubes (inside and at top of fire box)... see item 9, page 17

\*AUGER JAMS: Though it would be highly irregular, you may experience an auger jam due to foreign objects in your fuel hopper or an unusual characteristic in the pellet fuel you are using. To clear an auger jam, disconnect the power and remove the rear cover of the stove (in the case of the insert, remove the shroud and, if necessary, pull the left side of the insert forward enough to reach the auger motor). Rotating the auger motor back and forth will dislodge the obstruction. Remove the obstruction from inside the hopper and reassemble the stove or insert.

ALL OTHER CONDITIONS OR PROBLEMS: **PLEASE CALL YOUR DEALER FOR ASSISTANCE IMMEDIATELY.**

