



INSTALLATION AND OPERATION MANUAL

Free-Standing Pellet Stove

Save These Instructions For Future Reference

P/N 900141-00, Rev. A, 05/2015



Pellet Stoves Model Winslow™ (PS40)



Report No. 14-187

A French manual is available upon request. Order P/N 900142-00.

Ce manuel d'installation est disponible en français, simplement en faire la demande. Numéro de la pièce 900142-00.

This appliance must be properly installed and operated in order to prevent the possibility of a house fire. Please read this entire manual before installation and use of this pellet fuel-burning room heater. Failure to follow these instructions could result in property damage, bodily injury or even death. Contact your local building or fire officials to obtain a permit and information on any installation requirements and inspection requirements in your area.

NATIONAL FIREPLACE INSTITUTE
NFI
CERTIFIED

www.nficertified.org

We recommend that our pellet hearth products be installed and serviced by professionals who are certified in the U.S. by the National Fireplace Institute® (NFI) as NFI Pellet Specialists or who are certified in Canada by Wood Energy Technical Training (WETT).

Wood Energy Technical Training
www.wettinc.com

	! WARNING
	<ul style="list-style-type: none"> • Hot! Do not touch! The glass and surfaces of this appliance will be hot during operation and will retain heat for a while after shutting off the appliance. Severe burns may result. • Carefully supervise children in the same room as appliance. • IHP pellet-burning appliances are designed for use as a supplemental heater. They are not intended for continuous use as a primary heat source.

IMPORTANT SAFETY AND WARNING INFORMATION

READ THIS MANUAL IN ITS ENTIRETY AND UNDERSTAND THESE RULES TO FOLLOW FOR SAFETY.

WARNING

Improper installation, adjustment, alteration, service or maintenance can cause injury or property damage. Refer to this manual. For assistance or additional information consult a qualified installer, service agency or the gas supplier.

WARNING

Do not attempt to alter or modify the construction of the appliance or its components. Any modification or alteration may void the warranty, certification and listings of this unit.

1. DO NOT CONNECT THIS UNIT TO A CHIMNEY FLUE SERVING ANOTHER APPLIANCE.
2. Do not connect this appliance to air ducts or any air distribution system.
3. DO NOT INSTALL A FLUE DAMPER IN THE EXHAUST VENTING SYSTEM OF THIS UNIT.
4. Do not use class B venting intended for gas appliances as a chimney or connector pipe on a pellet-fired appliance.
5. The minimum clearances must be maintained for all combustible surfaces and materials including; furniture, carpet, drapes, clothing, wood, papers, etc. Do not store combustibles within this clearance space (see Clearances on Pages 8 and 9).
6. **INSTALLATION DISCLAIMER** - It is imperative that the exhaust venting system be installed correctly and sealed gas-tight (not allowing exhaust to leak). Follow the vent manufacturer's instructions for proper installation. Since IHP has no control over the installation of your stove, IHP grants no warranty, implied or stated for the installation or maintenance of your stove and assumes no responsibility for any consequential damage(s).
7. Burning any kind of fuel consumes oxygen. If outside air is not ducted to the appliance, ensure that there is an adequate source of fresh air available to the room where the appliance is installed.
8. The appliance will not operate using natural draft, nor without a power source for the blower and fuel feeding systems.
9. Never use gasoline, gasoline-type lantern fuel, kerosene, charcoal lighter fluid, or similar liquids to start or "freshen up" a fire in this heater. Keep all such liquids well away from the heater while it is in use.
10. The authority having jurisdiction such as municipal building department, fire department, fire prevention bureau, etc should be consulted before installation to determine the need to obtain a permit.
11. **APPROVED FUEL:** This appliance is designed specifically for use only with pelletized wood pellets or a mixture of up to 50% corn mixed with a minimum of 50% pelletized wood pellets. This mixture of wood pellets and corn should be evenly pre-mixed before being placed in the units hopper. This appliance is designed and approved for the burning of wood residue pellets with up to 2% ash content. This appliance is NOT approved to burn cardboard, nut hulls, cherry pits, etc. regardless if it is in pellet form. Failure to comply with this restriction will void all warranties and the safety listing of the stove. Consult with your IHP dealer for more information on approved pellet fuels.
12. These appliances are designed as supplemental heaters. Therefore, it is advisable to have an alternate heat source when installed in a dwelling.
13. **CONTINUOUS OPERATION:** When operated correctly, this appliance cannot be overfired. Continuous operation at a maximum burn can, however, shorten the life of the electrical components (blowers, motors and electronic controls) and is not recommended. Typical approved operation would include running at the low to mid range setting with occasional running on the maximum setting during the coldest periods of the winter. **DO NOT OVER-FIRE THIS STOVE.** Follow all instructions regarding the proper use of this stove.
14. **CAUTION: NEVER PUT FINGERS NEAR AUGER.** This appliance is equipped with a hopper lid switch, which is designed to stop the auger when the hopper lid is opened. **NEVER DISCONNECT OR BYPASS THIS SWITCH FOR ANY REASON.** Pellet fuel is fed to the Burn-Pot by a screw auger. This auger is driven by a high torque motor. The auger is capable of causing serious harm to fingers. Keep pellets in the hopper at all times and keep fingers away from auger. The auger can start and stop automatically at any time while the stove is running.
15. **CAUTION: HOT WHILE IN OPERATION.** An appliance hot enough to warm your home can severely burn anyone touching it. Keep children, pets, clothing and furniture away. Contact may cause skin burns. Do not let children touch the appliance. Train them to stay a safe distance from the appliance.
16. **FLY ASH BUILD-UP:** For all wood pellet fuel-burning heaters, the combustion gases will contain small particles of fly-ash. This will vary due to the ash content of the fuel being burned. Over time, the fly-ash will collect in the exhaust venting system and restrict the flow of the flue gases. The exhaust venting system should be inspected regularly and cleaned as necessary.
17. **SOOT FORMATION:** Incomplete combustion, such as occurs during startup, shutdown, or incorrect operation of the room heater will lead to some soot formation which will collect in the exhaust venting system. A precautionary inspection on a regular basis is advisable to determine the necessity of cleaning. The exhaust venting system should be inspected regularly and cleaned as necessary.
18. **DISPOSAL OF ASHES:** Ashes should be placed in a steel container with a tight fitting lid and moved outdoors immediately. The closed container of ashes should be placed on a noncombustible floor or on the ground, well away from all combustible materials, pending final disposal. If the ashes are disposed of by burial in soil or otherwise locally dispersed, they should be retained in the closed container until all cinders have been thoroughly cooled.
19. The instructions must be strictly adhered to. Do not use makeshift methods or compromise in the installation.
20. Do not abuse the door glass by striking, slamming or similar trauma. Do not operate the stove with the glass removed, cracked or broken.
21. **SAVE THESE INSTRUCTIONS.**
22. See the listing label on the appliance.

CONGRATULATIONS!

When you purchased your new pellet stove, you joined the ranks of thousands of individuals whose answer to their home heating needs reflects their concern for aesthetics, efficiency and our environment. We extend our continued support to help you achieve the maximum benefit and enjoyment available from your new pellet stove.

It is our goal at IHP to provide you, our valued customer, with an appliance that will ensure you years of trouble-free warmth and pleasure.

Thank you for selecting a IHP stove as the answer to your home heating needs.

TABLE OF CONTENTS

Important Safety Warnings	Page 2
Using This Manual	Page 3
Planning Your Installation	Page 4
Smoke Detector Recommended.....	Page 4
Carbon Monoxide Monitor Recommended	Page 4
Selecting Your Location	Page 5
Negative Pressure Warning.....	Page 5
Features And Specifications	Page 6
Stove Dimensions	Page 7
Clearances To Combustibles	Page 7
Hearth Protection	Page 9
Vent Termination Requirements	Page 9
Vent Termination Locations	Page 10
Installation	Page 11-19
Venting	Page 11
Fireplace Chimney Installations	Page 12
Vertical Vent.....	Page 13
Mobile Home Installation	Page 13
Outside Air	Page 13
Thermostat	Page 13
Door Trim Installation Instructions	Page 14
Door Grill Installation Instruction	Page 16
Brick Panel Installation Instructions	Page 17
Log Set Installation Instructions	Page 19
Operation	Page 20-21
Control Board	Page 20
Filling The Hopper	Page 20
Lighting Your Pellet Stove	Page 20
Manual Operation	Page 20
Thermostat Operation	Page 20
Shut Down	Page 21
Paint Curing	Page 21
Convection Blower Operation	Page 21
Operating Sounds	Page 21

Pellet Fuel	Page 21
Corn Fuel	Page 21
Cautions	Page 21
Cleaning and Maintenance	Page 22-26
Burn-Pot Cleaning	Page 22
Cleaning Glass	Page 22
Ash Drawer Removal And Cleaning	Page 22
Inspect Gaskets	Page 23
Cleaning Heat Exchanger	Page 23
Cleaning Flue Gas Passageways	Page 23
Cleaning Combustion Blower	Page 24
Cleaning Convection Blower	Page 24
Cleaning Vent Pipe	Page 24
Cleaning "Proof of Fire" Switch	Page 25
Front Door Removal	Page 25
Side Door Removal	Page 25
Back Removal And Lower Cover Plate	Page 25
Component Location and Functions.....	Page 26-27
Igniter	Page 26
Vacuum Switch	Page 26
Auger And Auger Motor	Page 26
Over Temperature Snap Switch (Manual Reset)	Page 26
Proof Of Fire Snap Switch	Page 26
Convection Blower Snap Switch	Page 26
Hopper Lid Switch	Page 26
Draft Adjuster	Page 27
Wiring Diagram	Page 27
Diagnostic Codes	Page 28
Troubleshooting	Page 28
Replacement Parts List	Page 30
Accessories.....	Page 31
Warranty	Page 33
Product Reference Information.....	Page 34

USING THIS MANUAL

Please read and carefully follow all of the instructions found in this manual. Please pay special attention to the safety instructions provided in this manual.

PRODUCT IS SUBJECT TO CHANGE WITHOUT NOTICE

PLANNING YOUR INSTALLATION

Questions To Ask Local Building Official

A correct installation is critical and imperative for reducing fire hazards and perilous conditions that can arise when wood pellet burning appliances are improperly installed. The installer must follow all of the manufacturers' instructions.

WARNING

Check all local building and safety codes before installation. The installation instructions and appropriate code requirements must be followed exactly and without compromise. Alterations to the stove are not allowed. Do not connect the stove to a chimney system serving another stove, appliance, or any air distribution duct. Failure to follow these instructions will void the manufacturers warranty.

The installation of this appliance must conform to local codes and applicable state and federal requirements. Familiarity with these requirements before installation is essential. Important considerations to discuss with local building officials include:

1. **Applicable codes** (i.e. Uniform Mechanical Code, State or Regional Codes).

Electrical codes:

In USA, NEC, ANSI/NFPA 70 – Latest Edition
In Canada, CSA C22.1 – Latest Edition

2. Local amendments
3. Is a permit required - cost. You may wish to contact your insurance company to ask if they require this.
4. If outside combustion air is required
5. Rooms where the installation is not allowed

Power Supply Requirements

The power cord must be plugged into a standard, 120 volt, 60 Hz grounded electrical outlet. The power supply cord must be routed to avoid contact with any of the hot or sharp exterior surface areas of the stove. When installed in a manufactured home, the appliance must be electrically grounded to the steel chassis of the manufactured home (see **Page 13**, Manufactured Home Requirements for additional requirements). These requirements must be met unless otherwise specified by state or local authorities.

Electrical

- The stove requires 120 volts AC for operation.
- Maximum wattage is 700.
- Igniter wattage is 400.
- Normal operating wattage is 300.

Electrical Generator Operation

Your Winslow™ PS40 stove can be powered with a gas driven electrical generator. However, the generator's electrical regulator may not be compatible with the stove's electronics. The higher the quality of the generator, the greater the chance that it is compatible with the stove.

WARNING

Electrical grounding instructions: This appliance is equipped with a three-prong (grounding) plug for your protection against shock hazard and should be plugged directly into a properly grounded three-prong receptacle. Do not cut or remove the grounding prong from this plug. Do not route power cord under or in front of appliance.

Smoke Detector Recommended

Since there are always several potential sources of fire in any home, we recommend installing smoke detectors. If possible, install the smoke detector in a hallway adjacent to the room (to reduce the possibility of occasional false activation from the heat produced by these appliances). If your local code requires a smoke detector be installed within the same room, you must follow the requirements of your local code. Check with your local building department for requirements in your area.

Carbon Monoxide Monitor Recommended

Carbon Monoxide Poisoning: Early signs of carbon monoxide poisoning are similar to the flu with headaches, dizziness and/or nausea. If you have these signs, obtain fresh air immediately. Some people are more affected by carbon monoxide than others, including pregnant women, people with heart or lung disease or anemia, those under the influence of alcohol, and those at high altitudes.

It is against federal regulations to operate wood heaters in a manner inconsistent with operating instructions in the manual.

Surge Protectors

A surge protector is recommended to ensure the stove's electrical components are not damaged due to a surge in the electrical supply. Only high quality protectors listed to UL1449 should be used - low quality protectors do not provide the protection needed.

Installation / Maintenance Standards

National Fire Protection Association – The primary NFPA standard that refers to installation and maintenance of pellet stoves and venting is NFPA 211 – Latest Edition: Chimneys, Fireplaces, Vents, and Solid Fuel appliances.

SELECTING A LOCATION

The design of your home and where you place your stove will determine its value as a source of heat. This type of appliance depends primarily on air circulation (convection) to disperse its heat, and therefore, a central location is often best. There are other practical considerations, which must be considered before a final selection of locations is made. Some of which includes:

- Existing Chimneys
- Pellet Fuel Storage
- Aesthetic Considerations
- Roof Design (rafter locations & roof pitch)
- Room Traffic
- Proximity to Combustibles
- Electrical Wiring



CAUTION

The body of these appliances are very heavy. The use of a heavy duty escalara (stair step hand truck) is recommended for lifting the appliance body.

NEGATIVE PRESSURE WARNING

This appliance is not designed to be operated in a negative pressure environment. In very airtight homes with large kitchen exhaust fans, furnace cold air returns, fresh air exchange systems and any other air system in close proximity to the heating appliance may create a negative pressure in the same room as the heating appliance. This can create dangerous condition, drawing combustion by-products into the home. Be sure your home has adequate makeup air to eliminate negative pressures caused by the above-mentioned sources. Outside air connected to the appliance probably will not resolve such a problem as the stove is not the source of negative pressure. IHP accepts no liability for damages resulting from negative pressures described here.

Ventilation Requirements - Provide adequate air for combustion. The fresh air requirements of this appliance must be met within the space where it will be installed. Ventilation is essential when using a solid-fuel-burning heater. In well insulated and weather tight homes, it may inhibit the rate the exhaust flows through the venting system (caused by a shortage of air in the home). The lack of air is caused by many common household appliances which exhaust air from the home (such as a furnace, heat pump, air conditioner, clothes dryer, exhaust fans, fireplaces, and other fuel burning appliances). Also, the combustion process of this heater uses oxygen from inside the dwelling. If the available fresh air delivery in the dwelling is insufficient to support the demands of these appliances, problems can result (i.e. excessive negative pressure will result in performance problems. To correct this problem it may help to open a window (preferably on the windward side of the house) or install an outside combustion air duct to the appliance.

Mountain View Hearth
manuals.stove-parts-unlimited.com

FEATURES AND SPECIFICATIONS

Installation Options

- Residential and Commercial
- Vented vertical and horizontal (see venting instructions)
- Manufactured home and mobile home
- Thermostat or manual operation
- Bedrooms

Heating

- Max. feed rate is 4.7 pounds/hour or 39,500 BTU/hour
- Min. feed rate is 1.8 pounds/hour or 15,120 BTU/hour

Venting

This stove is approved for venting with Type L and Type PL pellet vent pipe listed to UL 641 and ULC S609. The flue collar on the stove accepts 3" diameter pipe.

The combustion air for this stove is drawn through a pipe at the lower rear of the stove. For mobile home installations a 3" ID flex line or pipe must be attached to the stove's air intake to draw air from outside the house. The vent pipe can be installed vertically or horizontally (see Venting section for recommended installations).

NOTE: When installing this stove at altitudes of 4000 feet and above, we suggest the use of 4" pellet vent.

Thermostat

This stove can be operated manually or with a thermostat.

Lighting

This stove is equipped with an electric self igniter for ease of ignition.

Weight - 305 pounds

Hopper Capacity - 60 pounds

Listing information

The Winslow™ PS40 stove is safety tested and listed with the following agencies:

- PFS Corporation to ASTM E 1509
- US EPA List of Approved Wood Heating Appliances
- List of Colorado Approved Pellet Stoves

Appearance Choices

The Winslow PS40 stove can be ordered with the following door trims and grills, log set and brick panel options:

Door Trim Kits

Black	79038
Gold	79034
Nickel	79037
Brushed Nickel	79035
Black Nickel	79036

Grill Kits

Black.....	79000
Gold.....	79001
Nickel	79002
Brushed Nickel	79022
Black Nickel	79039

Log Set H5142

Brick Panel Kit 79030

FUEL



CAUTION

The use of unapproved, dirty, wet and / or high salt content fuel will void the warranty!

This stove is designed to burn wood pellet fuel. In addition, a corn/wood pellet mixture, with a maximum of 50 percent corn can be burned. Burning any other fuel that is not approved for use with this appliance will void the appliance warranty. **IMPORTANT: The corn/wood mix needs to be mixed evenly before being put in the pellet stove hopper.**

Wood Pellet Specifications

This appliance has been designed to burn wood residue pellets with up to 2% ash content. Dirty fuel will adversely affect the performance of the stove. Any questions regarding pellet fuel can be answered at the Pellet Fuels Institute (PFI), pelletheat.org.

Pellet fuel is made from sawdust and scrap wood from many different species of wood. Pellets are either 1/4" or 5/16" in diameter and vary in length. The PS40 stove will burn either diameter pellets. Pellets made from hardwoods contain more ash than those made from softwoods. Minerals from ash and sand in the pellets form clinkers under the extreme temperatures in the Burn-Pot. Try burning various brands of pellets until you find one that burns with minimum ash and clinkers. Once you find a pellet brand that burns well, continue using this brand. High ash fuel increases the frequency of stove cleaning. Fuel with an excessive moisture content may jam the auger assembly.

Clinkering - Silica (or sand) in the fuel, along with other impurities, can cause clinkering. A clinker is a hard mass of silica formed in the burning process. Clinkering is a function of the fuel, (not the stove), but adversely affects the performance of the stove by blocking off the air passages in the Burn-Pot. Even P.F.I. approved pellet fuel may tend to clinker. See *Maintenance* for more information on cleaning.

Pellet Fuel Storage -

- **Store your wood pellets in a dry place to prevent them from absorbing excess moisture.**
- **Do Not store your wood pellets within the clearance zone of the stove.**
- **Do Not store your wood pellets in a place that would block access to refueling the hopper.**

Wood pellets manufactured to the pellet fuels institute (P.F.I.) certification standard are available in two grades, Standard and Premium. The primary difference between the two is the ash content of the pellets.

The P.F.I. specification for standard grade and premium grade residential and commercial pellet fuel is as follows:

- CHLORIDES (Salt): Less than 300 p.p.m. to avoid stove and vent rusting.
- BULK DENSITY: 38 to 40 lb. / Cu. Ft. minimum
- MOISTURE CONTENT: 8% to 10% maximum
- ASH CONTENT: < 2% maximum (standard grade) < 1% maximum (premium grade)
- FINES: 0.5% to 1% maximum through a 1/8" screen
- BTU CONTENT: There are a number of variations in pellet fuels that are not included in PFI standards. For example, BTU (heat value) content may range from just under 8,000 to almost 9,000 Btu, depending upon species and region of the country and other variables.

Corn Fuel Specifications

Use only clean-shelled corn with a moisture content less than 15% and approximate fuel value of 7000 BTU/lb (16,200 kJ/kg). Do not attempt to burn corn with higher moisture content or burn lesser grade fuels. Do not burn other types of agricultural pellets or by-products (alfalfa, cherry pits, olive pits, nut shells, etc.) as they are not permitted to be burned in these appliances.

Shelled corn can be burned in the PS40 pellet stove when it is mixed with wood pellet fuel. The mixture can contain a maximum of 50 percent corn. Burning corn may create more ash than wood pellets and may necessitate the need to clean the Burn-Pot and glass more frequently.

Store corn in a tight container and use methods to ensure the corn does not become rain soaked or absorb moisture from damp or wet sources. This will also prevent rodents from becoming a problem. Do not store corn within stove installation clearances.

NOTES:

- **Corn with excessive grain dust must be screened, by sifting with 3/16" mesh screening. Large pieces of cob may plug the auger.**
- **When changing from burning all wood pellets to burning a corn and wood pellet mix, the draft adjuster may need to be adjusted to achieve proper combustion.**

! WARNING

Do not burn treated seed corn! Seed corn is treated with chemical pesticides that are harmful or fatal if swallowed. Burning treated corn will void your warranty!

STOVE DIMENSIONS

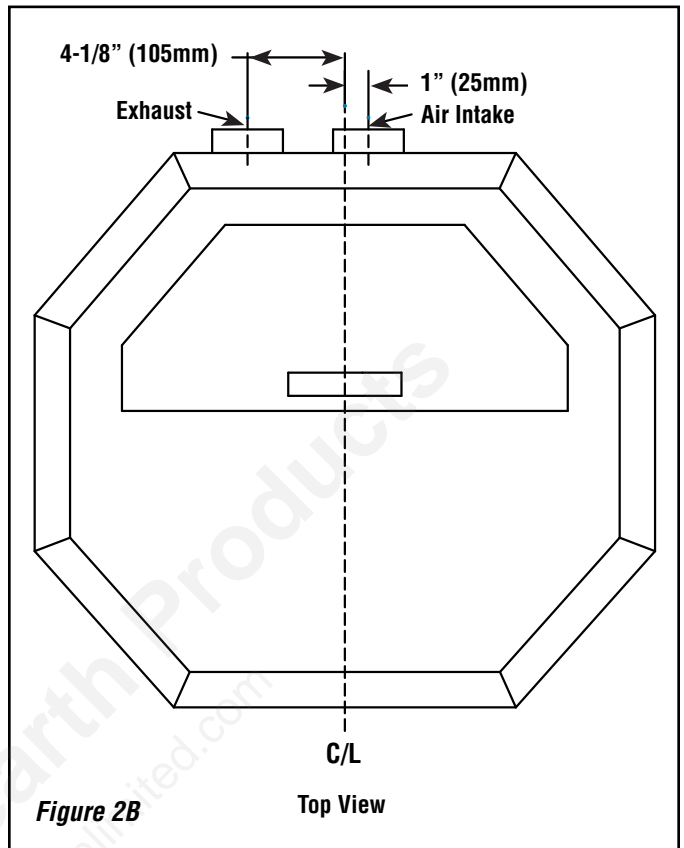
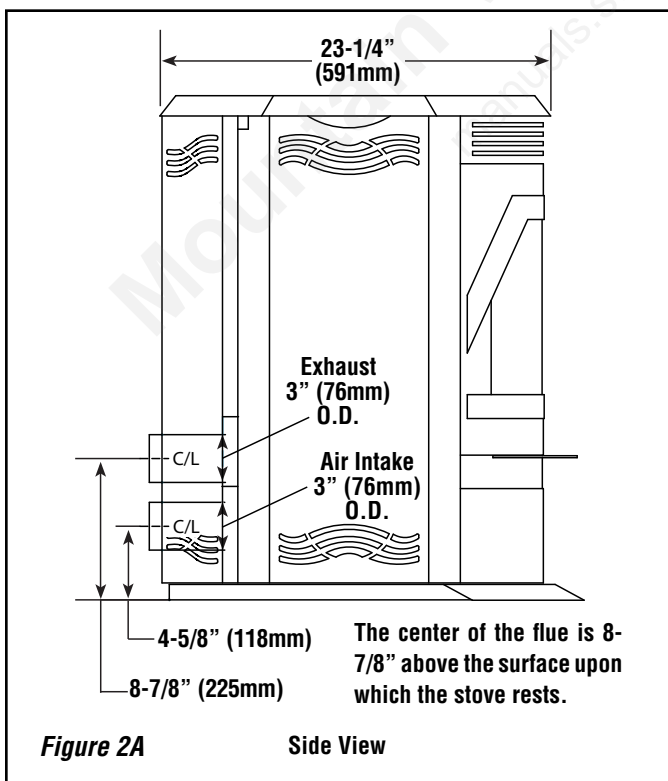
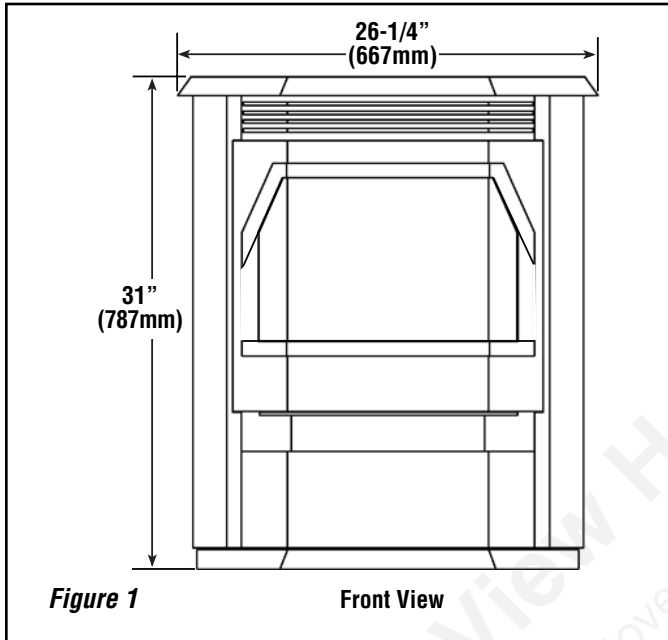

CLEARANCES TO COMBUSTIBLES

! IMPORTANT

- *Minimum clearances specified may not allow for ease of operation and maintenance (please take this in to account when planning the installation). If installed to the minimum clearances, removal of the appliance may be necessary for servicing.*
- *Recommended clearance zone from the front of the appliance to combustibles is 4 feet minimum.*
- *Clearances to combustibles for the appliance can only be reduced by means approved by the regulatory authority.*

INSTALL VENT AT CLEARANCES SPECIFIED BY THE VENT MANUFACTURER.

**Corner Installations - Clearance to Combustibles
Left Wall Horizontal Venting**

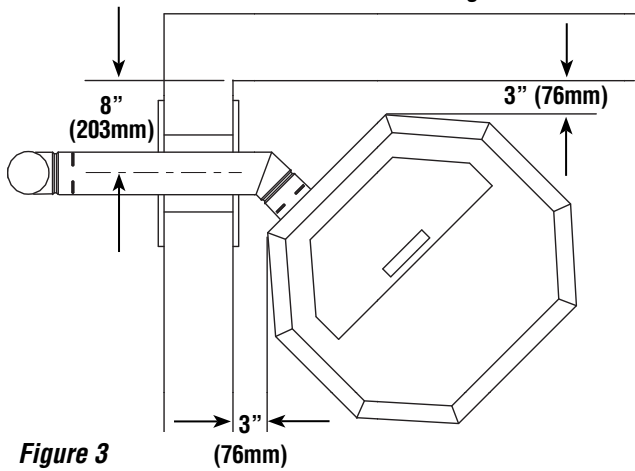

Figure 3

**Corner Installations
Clearance to Combustibles
Right Wall Horizontal Venting**

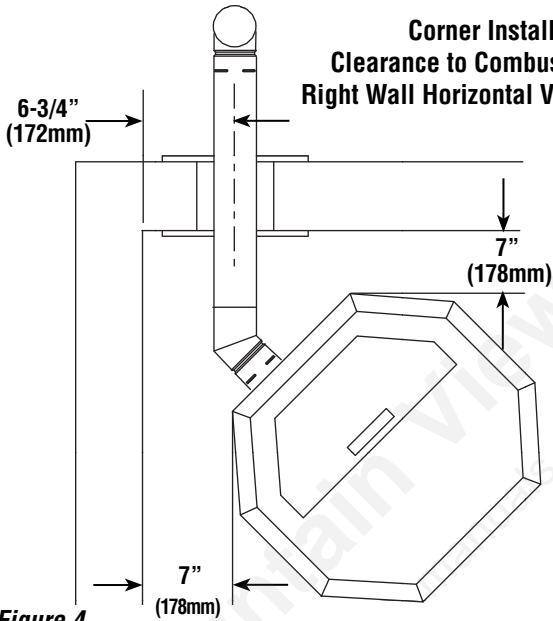

Figure 4

**Corner Installations
Clearance to Combustibles
Vertical Venting**

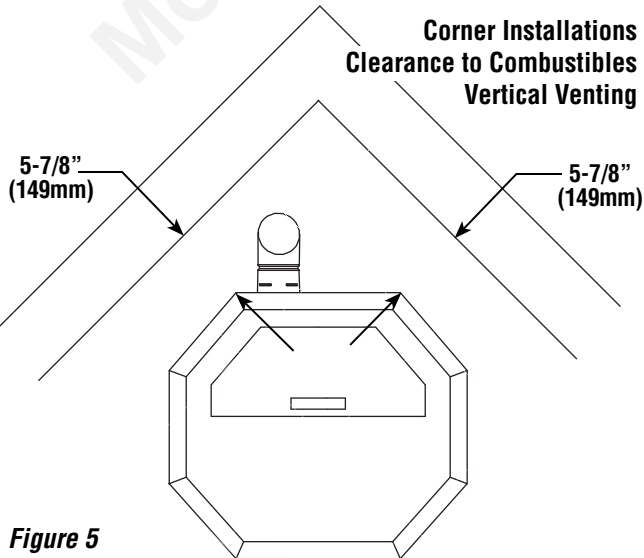

Figure 5

**Parallel Installations - Clearance to Combustibles
Vertical Venting**

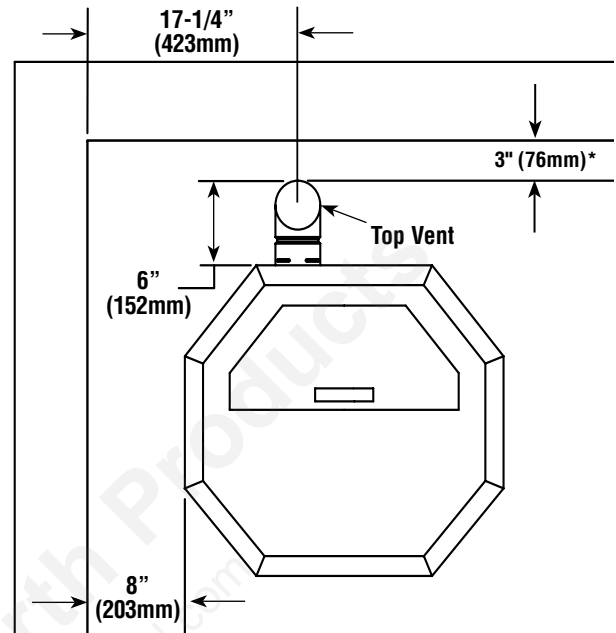

Figure 6

**Horizontal Venting
Clearance to Combustibles**

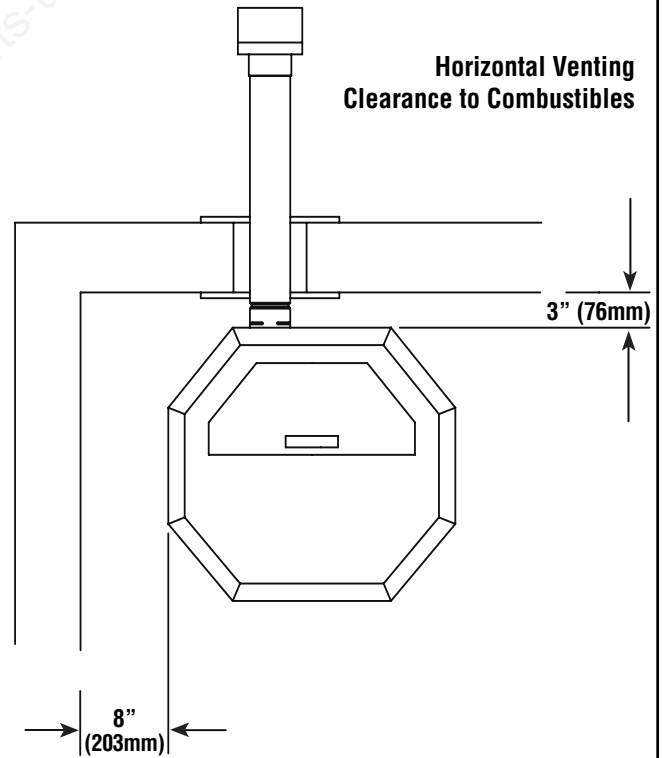

Figure 7

* Refer to pipe Manufacturer's installation instructions for minimum pipe clearances.

NOTE: DIAGRAMS & ILLUSTRATIONS ARE NOT TO SCALE.

Alcove Installations

Minimum alcove height is 41" (1041 mm), minimum width is 42-1/4" (1073 mm) and maximum depth is 48" (1219 mm). Note, it is quite difficult to load pellets into the hopper when installed in an alcove only 41" (1041 mm) high. For alcove wall clearances see parallel clearances below.

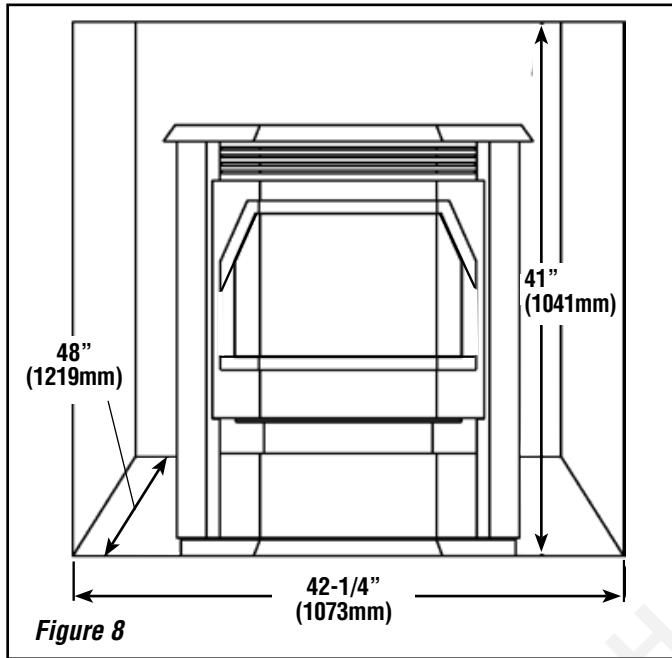

HEARTH PROTECTION

This appliance requires noncombustible floor protection (**the hearth pad or alternate floor protection material does not require a thermal rating**).

A noncombustible floor protector must fully cover the area beneath the appliance as illustrated in **Figure 9**.

If the floor protection is to be stone, tile, brick, etc., it must be mortared or grouted to form a continuous noncombustible surface. In Canada, if a chimney connector / venting extends horizontally over the floor, protection must also cover the floor under the connector / venting and at least 2" (51 mm) to either side (recommended but not required in the US).

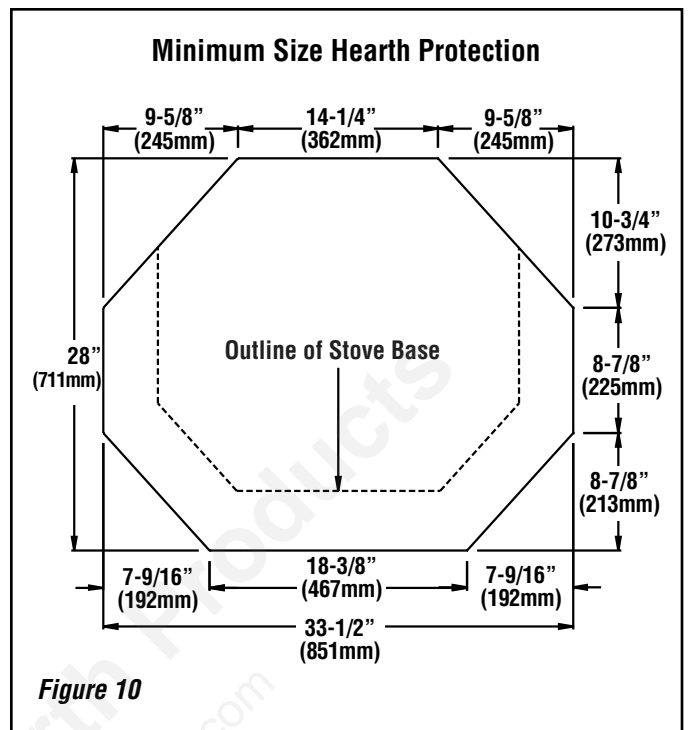
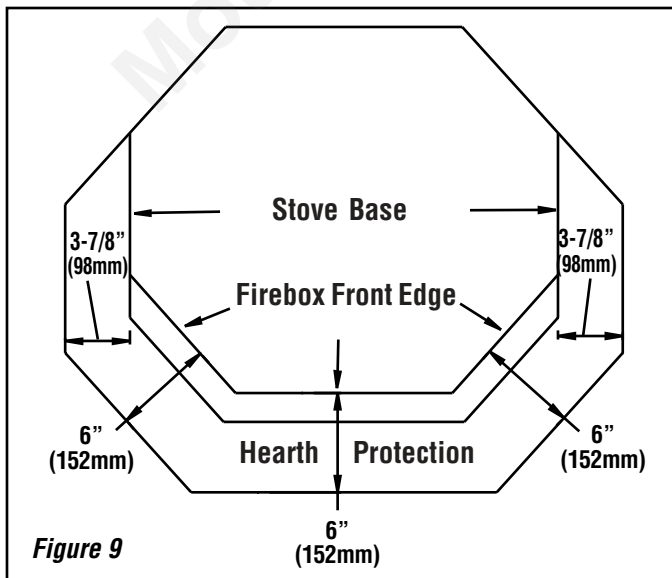

VENT TERMINATION REQUIREMENTS

1. Do not terminate the vent in any enclosed or semi-enclosed areas such as a carport, garage, attic, crawlspace, narrow walkway, closely fenced area, under a sundeck or porch, or any location that can build up a concentration of fumes such as stairwells, covered breezeway, etc.
2. Vent surfaces can become hot enough to cause burns if touched. Non-combustible shielding or guards may be required.
3. Termination must exhaust above the inlet elevation. It is recommended that at least five feet of vertical pipe be installed outside when the stove is vented directly through a wall. This will create a natural draft to prevent the possibility of smoke or odor during appliance shut down or power failure and avoid exposing people or shrubs to high temperatures.
4. The vent should terminate no less than four feet below, no less than four feet horizontally from and no less than one foot above doors and windows, or gravity/ventilation air inlets into the building.
5. The distance from the bottom of termination to grade is 12" (305 mm) minimum unless otherwise specified by the vent manufacturer. The distance between the bottom of the termination and a public walkway should be a minimum of seven feet.
6. Locate the vent termination at least two feet away from combustible materials such as shrubs, plants, grass, fences, roof overhangs and adjacent buildings.

NOTE: DIAGRAMS & ILLUSTRATIONS ARE NOT TO SCALE.

VENT TERMINATION LOCATIONS

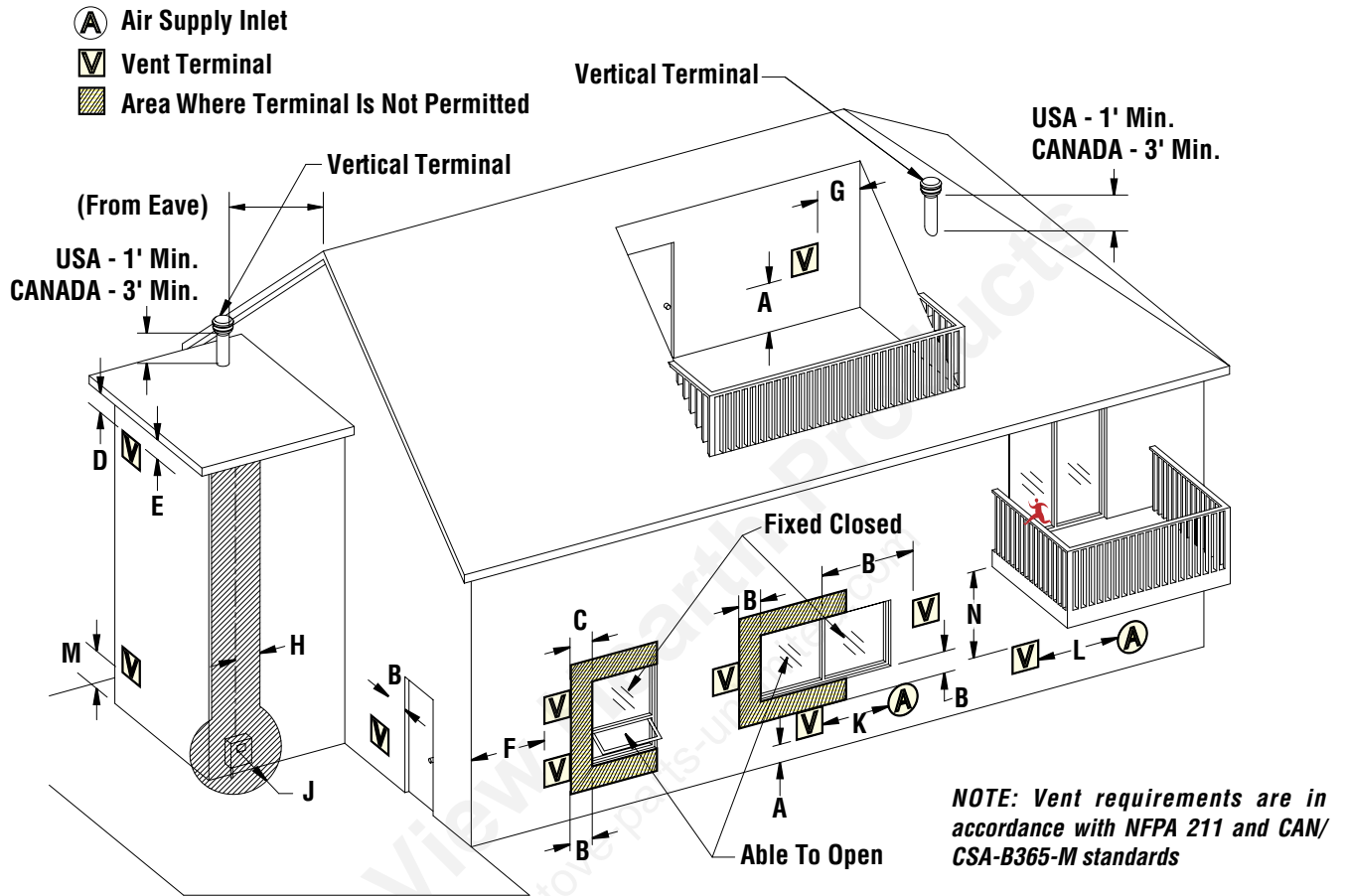

- A = Refer to vent manufacturer's installation instructions for the required clearance above grade, veranda, porch, deck, or balcony.
- B = Clearance to window or door that may be opened (min. 12"/30cm above - 48"/1.2m below and to the side)
- C = Clearance to permanently closed window *(min. 12"/30cm)
- D = Vertical clearance to ventilated soffit located above the terminal within a horizontal distance of *(min. 24"/60cm) from the centerline of the terminal (min. 22"/55cm) check with local code.
- E = Clearance to unventilated soffit *(min. 12"/30cm)
- F = Clearance to outside corner *(min. 12"/30cm)
- G = Clearance to inside corner *(min. 12"/30cm)
- H = Not to be installed above a meter/regulator assembly within *(min. 36"/90cm) horizontally from the centerline of the regulator.
- J = Clearance to service regulator vent outlet *(min. 72"/1.8m)
- K = Clearance to non-mechanical air supply inlet to building or the combustion air inlet to any other appliance *(min. 48"/1.2m)

- L = Clearance to a mechanical air supply inlet *(min. 120"/3.1m)
- M = **Clearance above paved sidewalk or a paved driveway located on public property *(min. 84"/2.1m)
- N = ***Clearance under veranda, porch, deck, or balcony (min. 12"/30cm)

NOTES:

- * Local codes or regulations may require different clearances.
- ** A vent shall not terminate directly above a sidewalk or paved driveway which is located between two single family dwellings and serves both dwellings.
- *** Only permitted if veranda, porch, deck, or balcony is fully open on a minimum of two sides beneath the floor.

Figure 11

INSTALLATION

Venting

This stove is approved for venting with Type L and Type PL pellet vent pipe listed to UL 641 and ULC S609. Single wall pipe cannot be used with this pellet stove. The stove's flue collar is 3" in diameter. An approved wall thimble or approved ceiling firestop must be used when the pellet pipe passes through a combustible wall or ceiling. The stove's combustion blower pressurizes and pushes flue gases out the pellet pipe. As a result, all pipe joints should be locked together or screwed with three screws if the pipe does not have a locking system and sealed with high temperature silicone. The pipe should be siliconed and fastened with three screws to the stove's flue collar.

In Canada, where the venting may pass through a wall, or partition of combustible materials, the installation shall conform to CAN/CSA-B365. When installing the wall thimble and other venting components, follow the vent manufacturers instructions. Maintain an effective vapor barrier at the location where the chimney or other component penetrates to the exterior of the structure.

The longer the run of pipe and the more elbows used, the greater the resistance to the flow of flue gases. Four inch diameter pellet pipe is recommended for pipe runs greater than 15 feet or when a number of elbows are used.

To aid in cleaning, whenever possible, the venting system should include a tee with clean out attached to the flue collar on the stove. **Do not install back to back elbows right off the back of the stove in any installation.**

DO NOT INSTALL A FLUE DAMPER IN THE EXHAUST VENTING SYSTEM OF THIS UNIT. DO NOT CONNECT THIS UNIT TO A CHIMNEY FLUE SERVING ANOTHER APPLIANCE.

Horizontal installations that terminate without any vertical sections of pipe are approved; however, wind may direct flue gases toward the house causing discoloring problems. For this reason, horizontal and up 5 feet or horizontal and through the eave installations are recommended.

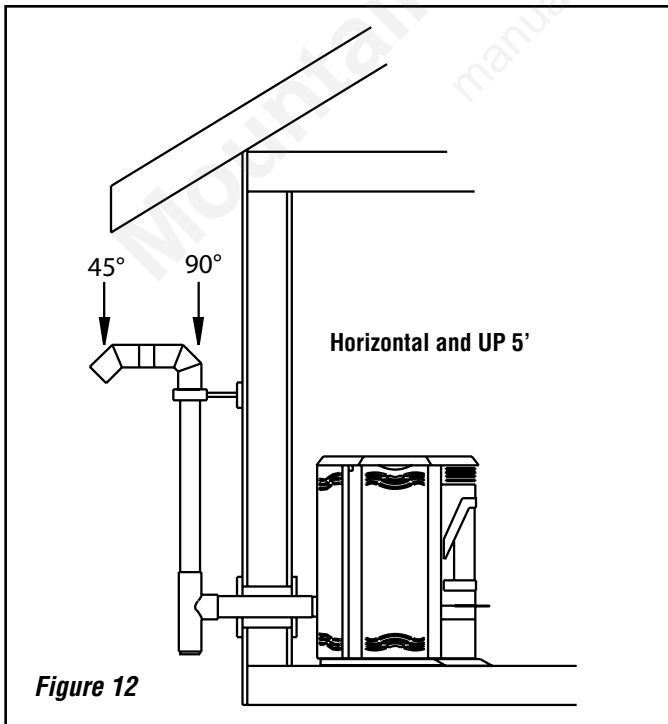

Figure 12

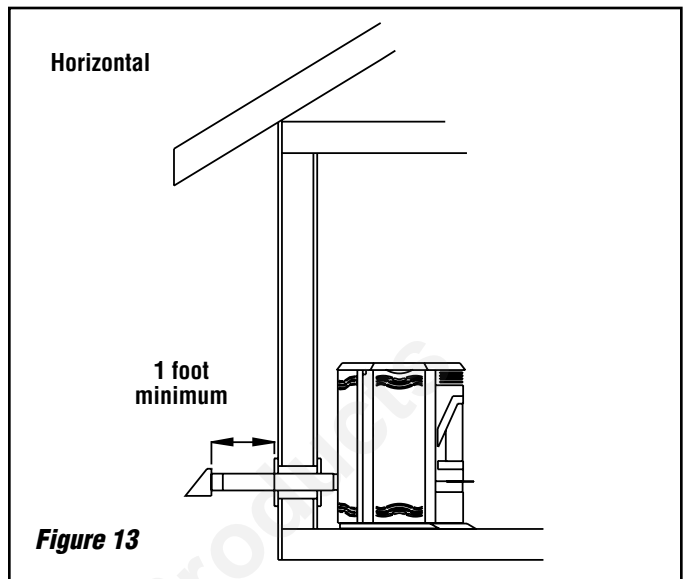

Figure 13

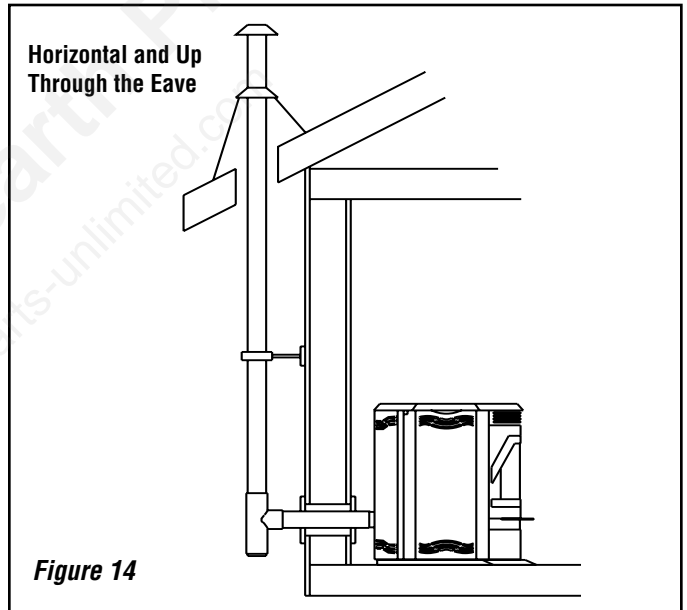
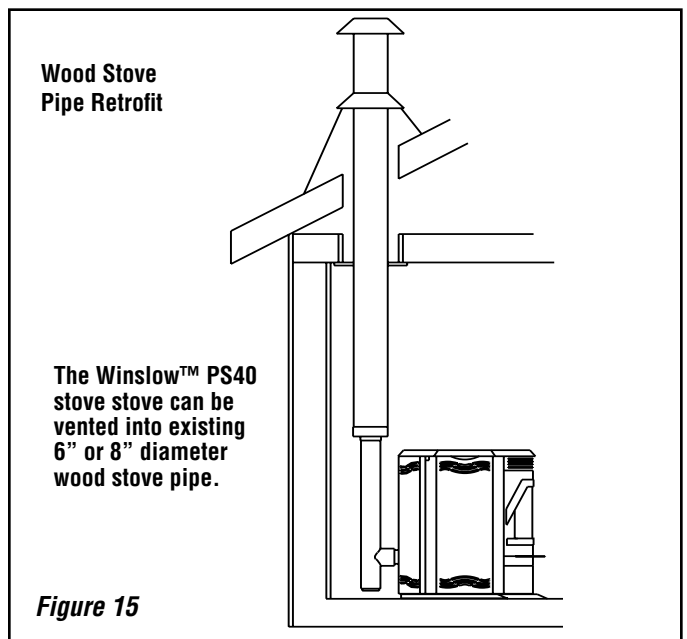

Figure 14



The Winslow™ PS40 stove can be vented into existing 6" or 8" diameter wood stove pipe.

Figure 15

NOTE: DIAGRAMS & ILLUSTRATIONS ARE NOT TO SCALE.

Masonry Chimney

When venting into a masonry chimney, the pellet pipe can terminate just inside the chimney. However, it is recommended to run the pellet pipe to the top of the chimney.

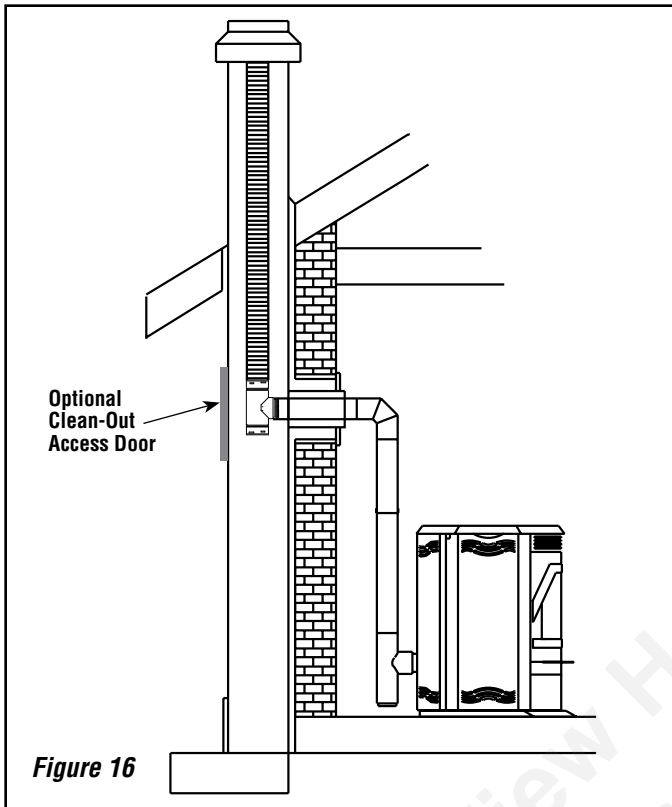

Fireplace

When venting into a fireplace chimney, the pellet pipe can terminate just above the damper. However, it is recommended to run the pellet pipe to the top of the chimney.

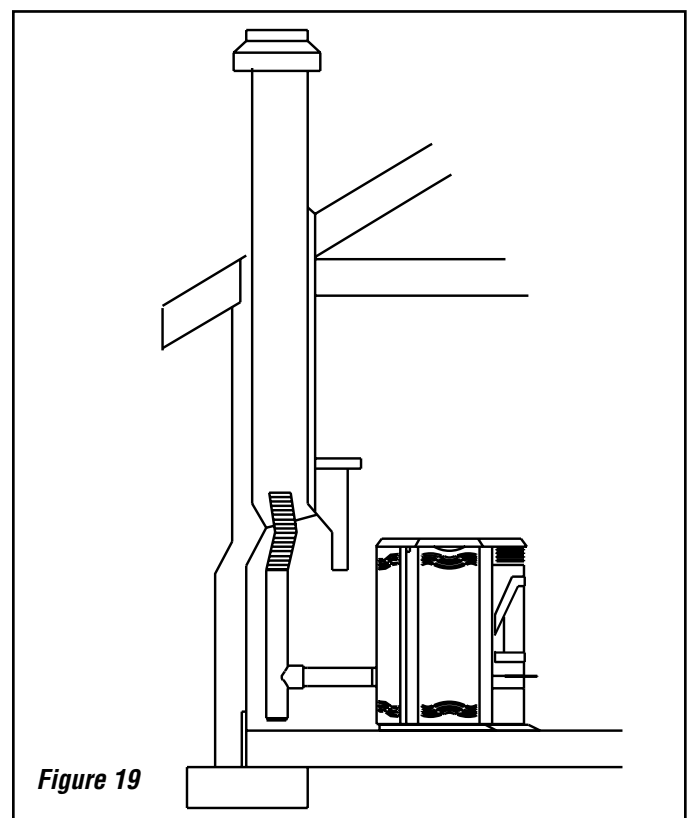
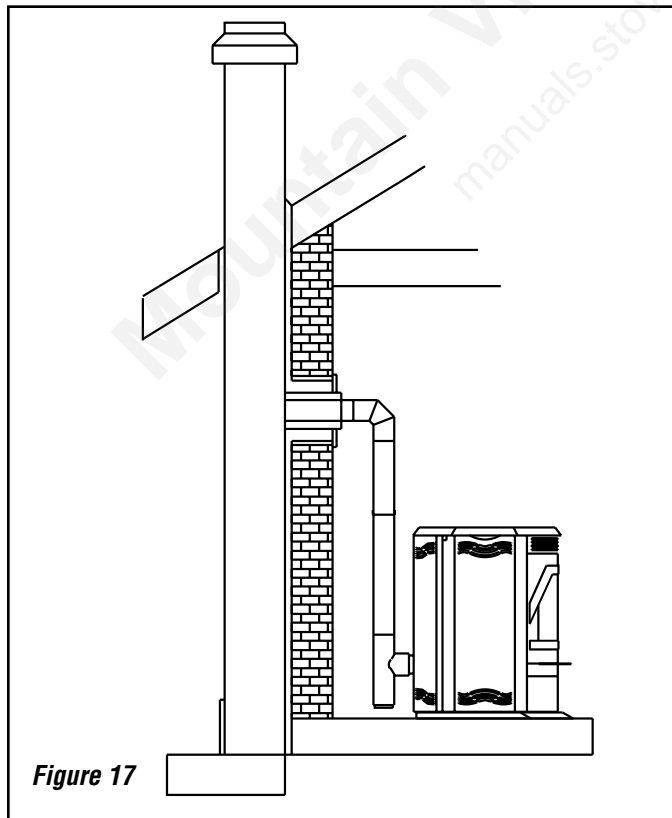
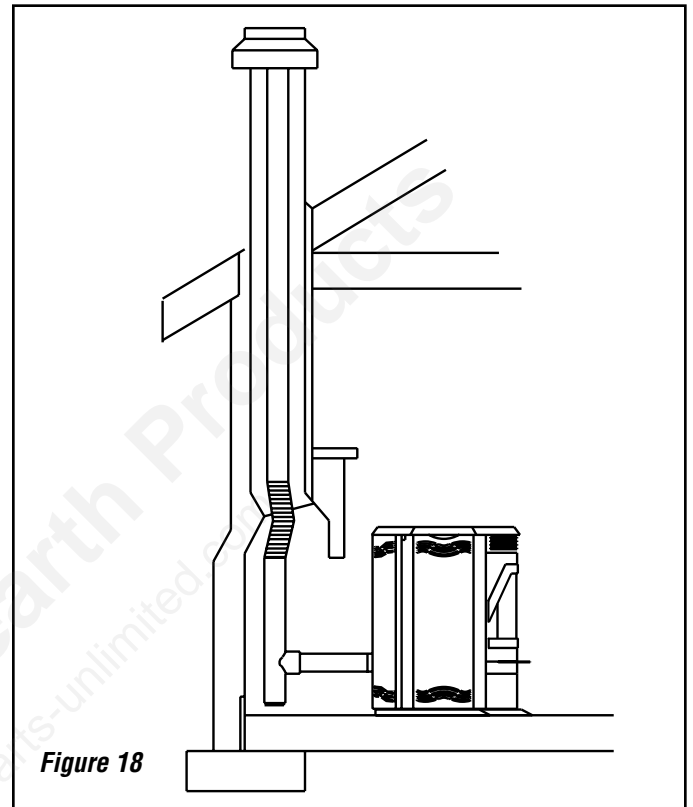

Vertical

If the length of pipe exceeds 15 feet, 4 inch pipe rather than 3 inch vent pipe should be used.

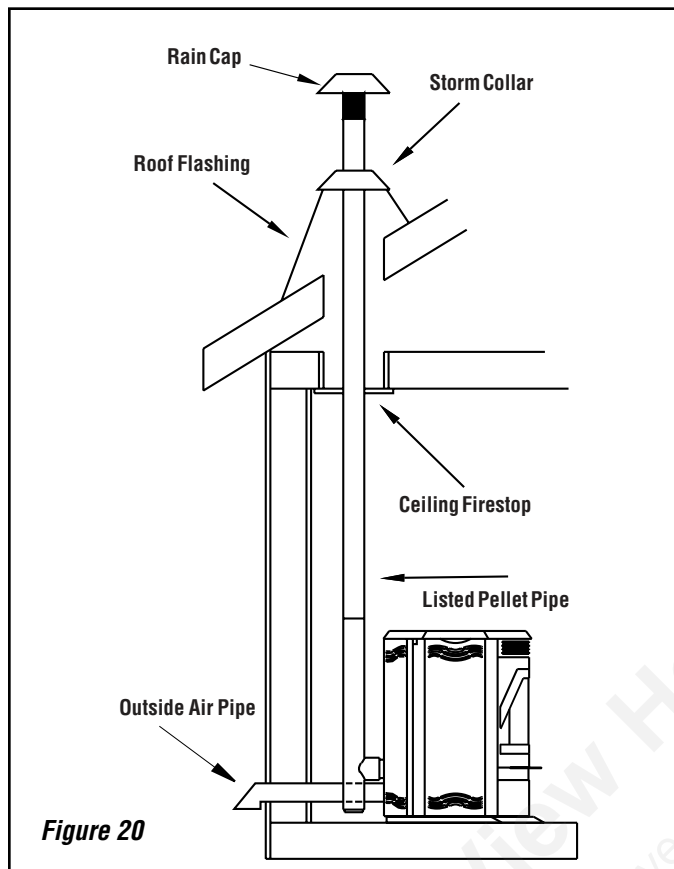

Figure 20

Mobile Home Installations

In addition to the standard installation instructions, the following instructions may be required by local, state or federal building codes.

- Installation should be in accordance with the Manufactured Home and Safety Standard (HUD), CFR 3280, Part 24.
- The stove must be permanently bolted to the floor using 1/4" diameter lag screws. The screws can be inserted through the holes in the pedestal located behind the side doors. The lag screws must be an adequate length to extend through the hearth pad and into the floor. A minimum of two lag screws must be used.
- Connecting the Winslow™ PS40 stove to outside combustion air is required in manufactured home installations and when required by local building codes. An outside air inlet must be provided for combustion and be unrestricted while unit is in use. Use a galvanized or stainless steel pipe for the duct (the outside air inlet on the stove is 3" diameter). The air intake on the exterior of the home should always be located a minimum of 18" below the flue termination. The Inlet shall remain free of obstruction while unit is in operation and constructed in a manner so as to prevent material from dropping into the inlet or into the area beneath the dwelling. The inlet shall also have a screen with openings not larger than 1/4" to prevent rodents from entering.
- The stove must be permanently electrically grounded to the steel chassis of the manufactured home using a 8 GA copper wire and a serrated or star washer (to penetrate paint or protective coating to ensure grounding). The location selected for ground attachment to the stove must be dedicated for this purpose. Grounding must comply with NFPA-70-latest edition standards, CSA C22.1-latest edition in Canada, as well as any local codes.

WARNING: DO NOT INSTALL THIS STOVE IN A SLEEPING ROOM IN A MANUFACTURED HOME.

CAUTION: THE STRUCTURAL INTEGRITY OF THE MANUFACTURED HOME FLOOR, WALL AND CEILING/ROOF MUST BE MAINTAINED.

Outside Air Installations

Connecting the Winslow PS40 stove to outside combustion air is required in manufactured home installations and when required by local building codes. The stove's air intake will accept 3" ID pipe to accommodate outside air installations. The air intake on the exterior of the home should always be located a minimum of 18" below the flue termination and must remain free of obstruction. The inlet must also have a screen with openings not larger than 1/4" to prevent rodents from entering.

Thermostat installation

The Winslow PS40 stove can be operated manually or by thermostat. The stove comes from the factory wired to operate manually - see control board operation on **Page 20**. A low voltage thermostat can be installed on the stove. To install the thermostat:

- 1) Unplug the stove from the electrical outlet. Open the right side door and lift out the control board from its retaining brackets. Locate the light green wiring block at the bottom back of the board (see **Figure 21**), loosen the two screws B at the back of the block and remove the U shaped jumper wire A protruding from the block.
- 2) Insert a wire from the thermostat into one of the slots from which the jumper wire was removed. Repeat this process for the other thermostat wire.

Retain the jumper wire for future reinstallation. See **Page 20** for thermostat operation instructions.

IMPORTANT NOTE: Install the thermostat per the manufacturers instructions, provided with the thermostat. Failure to follow manufacturers instructions could result in a malfunction. Pay special attention to the thermostat location requirements. If the location requirements are not adhered to the appliance, erratic operation or failure may occur.

Do not mount the thermostat where it may be affected by:

- Radiant heat from the stove, fireplaces, sun or other heat sources.
- Drafts or dead spots behind doors or in corners.
- Hot or cold air from ducts.

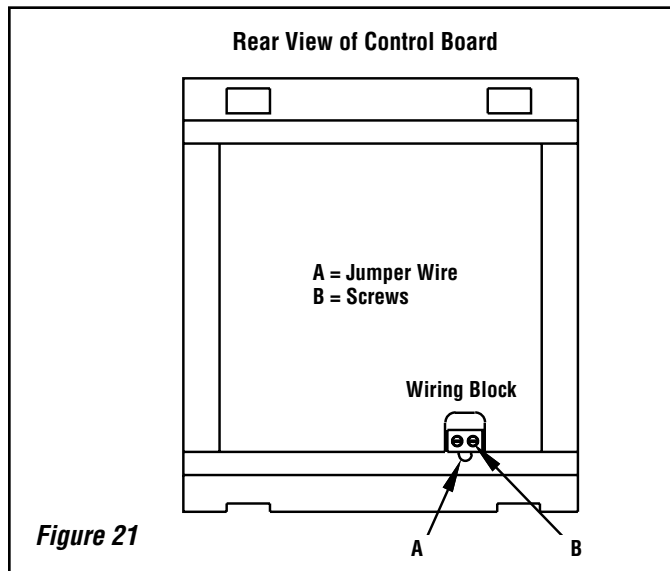

Figure 21

NOTE: DIAGRAMS & ILLUSTRATIONS ARE NOT TO SCALE.

Door Trim Installation Instructions

(ref. form # 775274M)

Parts List (A):

Qty

- (2) Trim Pieces (Gold, Nickel, Brushed Nickel or Black Nickel)
- (6) #10 nuts
- (6) #10 washers

Tools Needed:

Qty

- (1) 3/8" nut driver or socket wrench

CAUTION: Always ensure that plated surfaces are clean and free of fingerprints before lighting stove. Fingerprints will leave permanent blemishes if left on plated surface when lit. When installation is complete, the trim should be gently cleaned with soft cloth and either alcohol or glass cleaner. Do not overtighten nuts, overtightening can create visible dimples on the plated surface.

To install Door Trim:

1. Remove the trim pieces and hardware from its packaging and ensure that all pieces are present before beginning installation. Take care not to scratch finished surfaces.
2. Open right and left side door. The side doors swivel open towards the back of the stove. See **Figure 24**.
3. Open front door. Put trim in place by inserting trim studs into the corresponding holes in the door (**Figures 22 and 25**). The top piece of trim will only fit in one direction, but the bottom piece can be installed incorrectly. When placing the bottom piece of trim, make sure there is a 9/16" gap between the top of the trim piece and the glass in the door (see **Figure 26**).

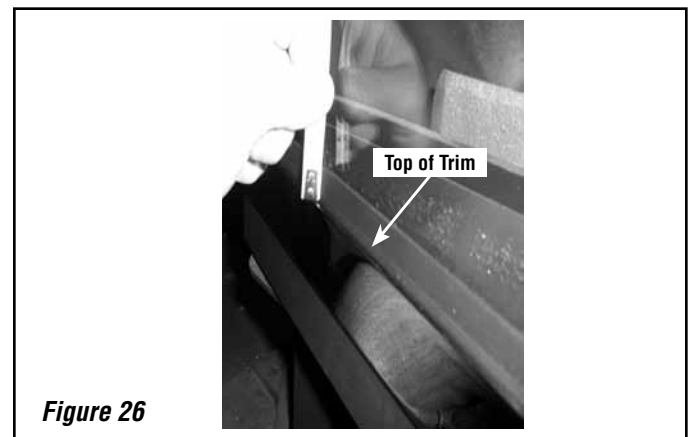
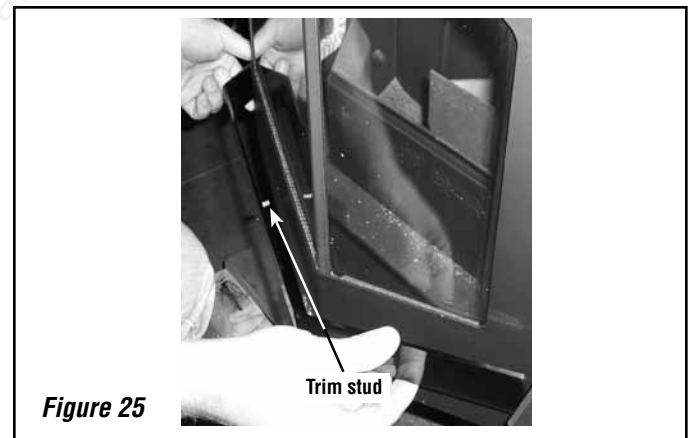
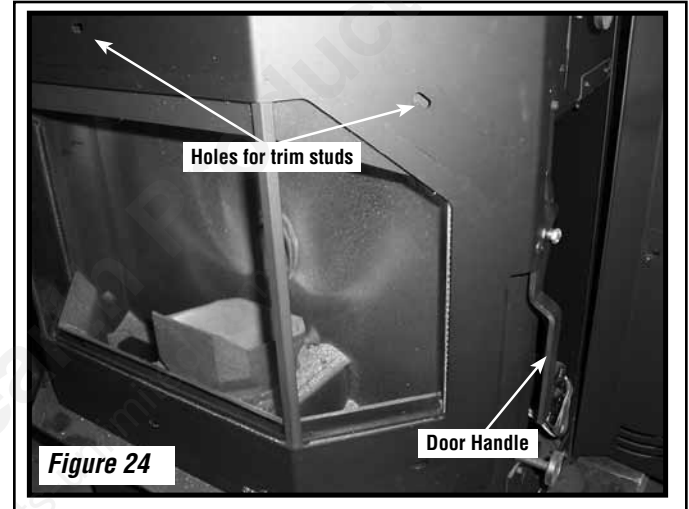
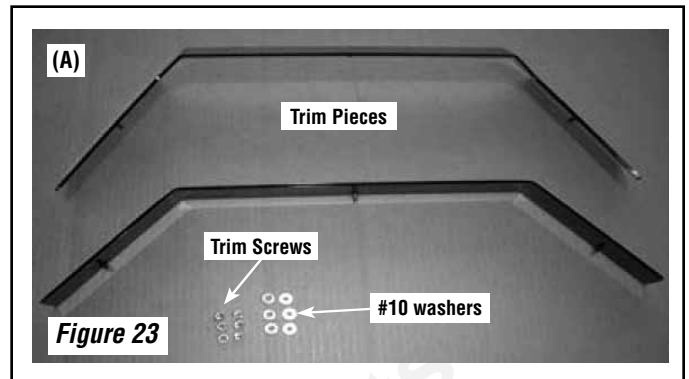
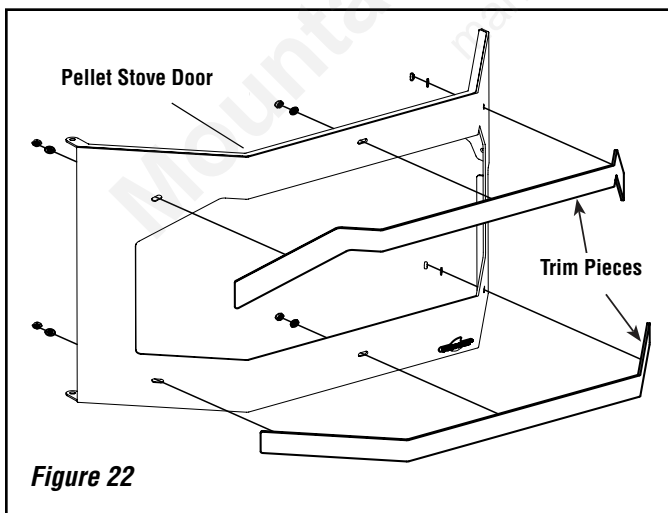

4. Place one washer on each stud. Using a 3/8" nut driver, snug up the nuts on each piece of trim. Do not finish tightening the nuts yet. See **Figure 27**.
5. There should be approximately a 7/8" (22 mm) gap between the top edge of the upper trim and the top edge of the door and a 1-1/2" (38 mm) gap between the bottom trim to the bottom of the door. Visually inspect the alignment of the trim and adjust if necessary. See **Figure 28**.
6. Finish tightening nuts. **CAUTION - DO NOT OVER-TIGHTEN NUTS, DIMPLING OF THE TRIM WILL OCCUR!!!**

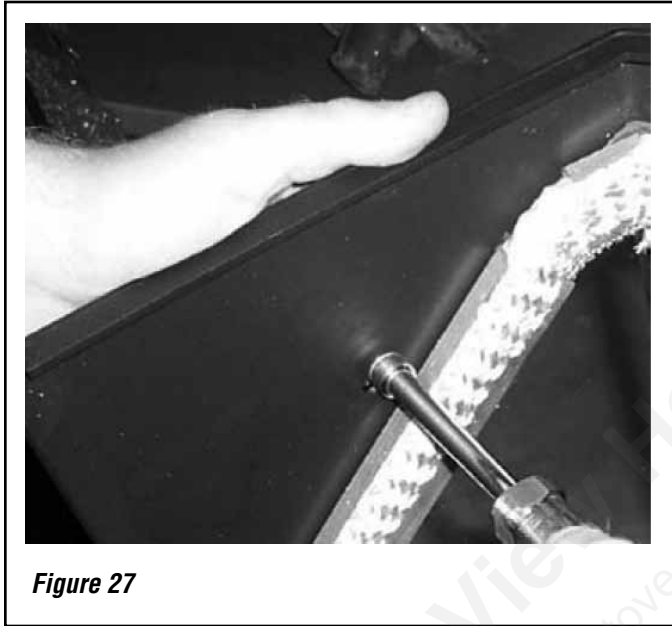

Door Grill Installation Instructions
(ref. form # 775273M)

Parts Needed:

Qty
(4) Button Head Screws (already in place in stove)

Tools Required:

Qty
(1) 1/8" allen wrench

To install the Grill:

1. Remove the four button head screws from body of the stove with a 1/8" allen wrench. See **Figure 29**.

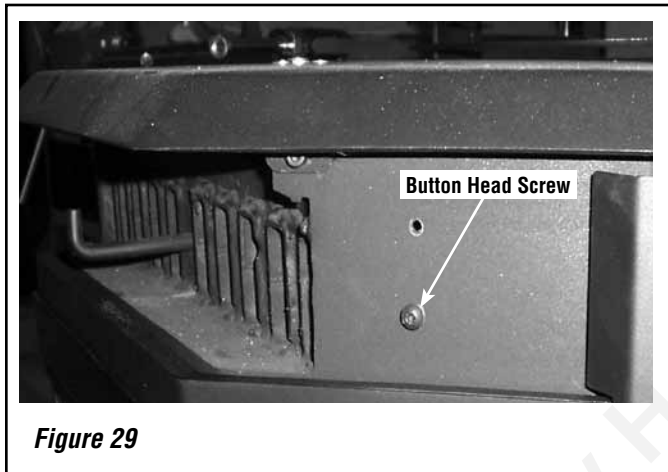

2. Pull the scraper rod out, rotate the grill vertically, (with the notch to the left) and slide the grill over the scraper rod (slide the rod between the third and fourth bar). See **Figure 30**.

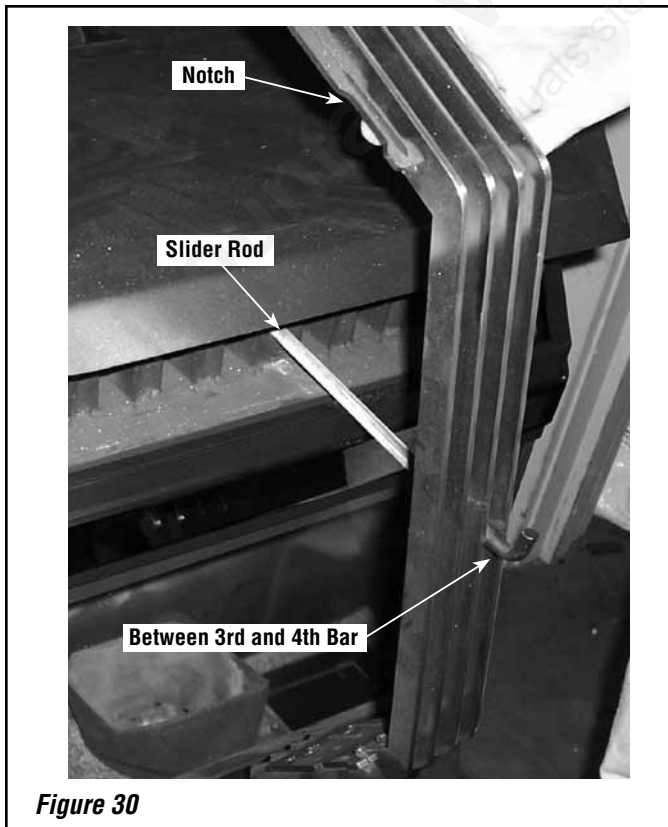

3. Rotate the grill back to the horizontal position and re-install the four button head screws through the two holes at each end of the grill and into the stove body. See **Figure 31**.

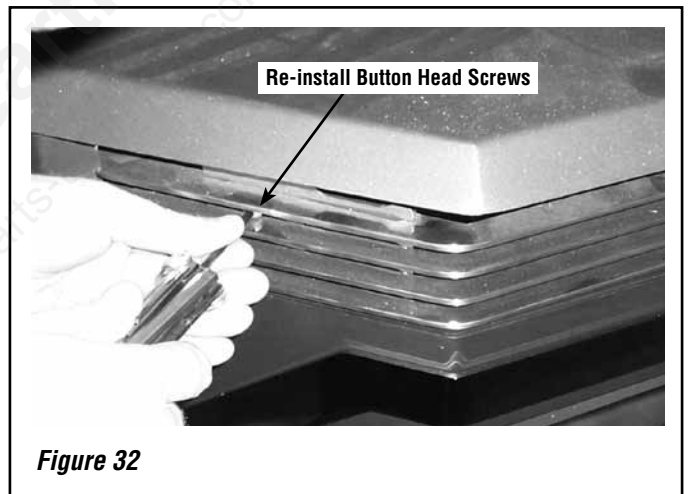
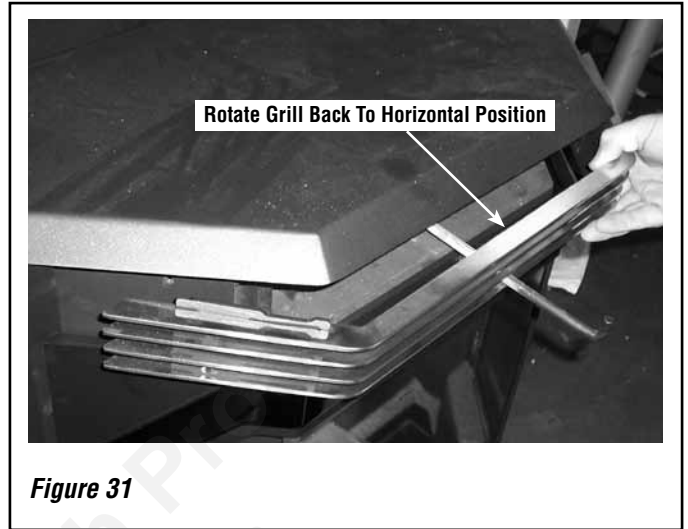

Brick Panel Installation

Option: Part #79030

Kit Contents:

- Brick Panel (A)
- 4 Tap Tights (B)

Tools Required:

- Drill (90° drill recommended)
- #18 drill bit
- 5/32 allen wrench

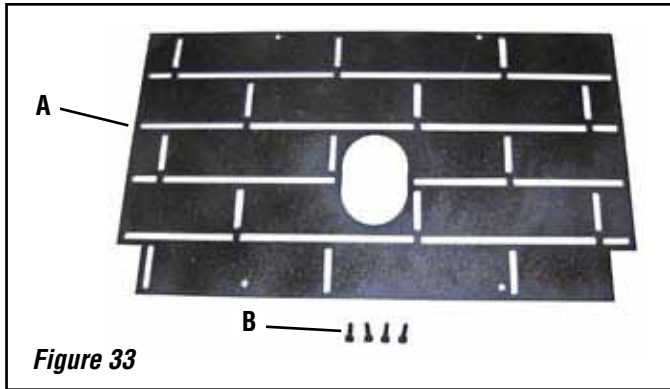

NOTE: The brick panel comes pre-painted with Metallic Black paint. The brick panel may be painted with any color of high-temp paint (paint may discolor with use).

1. Remove the front door of the pellet stove. To remove the front door, open the two side panels, swing open the front door and lift it up and off of its hinges. Remove the optional log set, if present and the Burn-Pot.



2. Remove all pellets and ash from the firebox to ensure a proper fit for the brick panel.
3. Insert the brick panel, top first, as shown in **Figure 35**. The two cut out corners should be at the bottom.



4. Make sure that the brick panel is centered, with equal space on either side of the auger tube. While holding the panel in place, use the drill with a #18 drill bit to drill out the four holes in the back of the firebox, as shown in **Figure 36**.

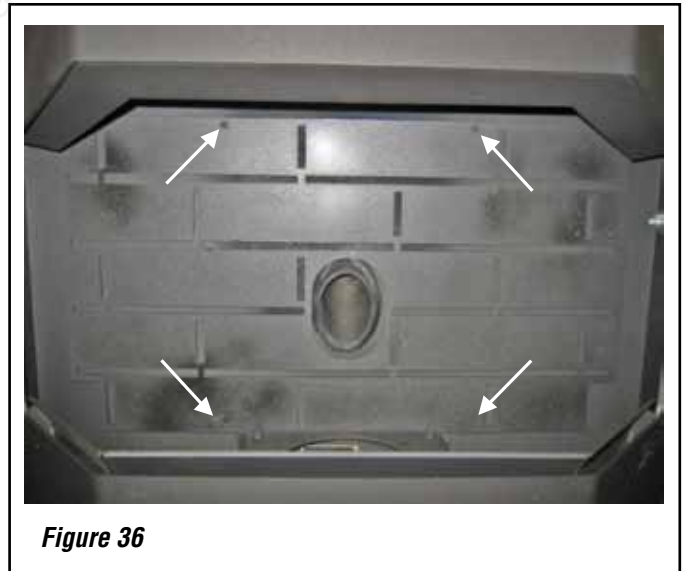

5. Screw in the four tap tights, included with this kit, using a 5/32 allen wrench.

6. Replace the Burn-Pot and check that it is firmly in place (if you can rotate the Burn-Pot it is not installed correctly). If present, install the optional log set according to the log set installation instructions (included with your log set).

7. Re-hang the door by reversing the instructions in step 1.



Figure 37

Mountain View Hearth Products
manuals.stove-parts-unlimited.com

Log Set Installation Instructions
(ref. form # 775275M)

Kit Contents
(refer to *Figure 38*)

- 1 ea. Left Log (A)
- 1 ea. Right Log (B)
- 1 ea. Front Log (C)
- 2 ea. Log Support Brackets (D)
- 1 ea. Instruction Sheet

Cat. No.	Model	Description
H 5142	P40LOG	Winslow Log Set

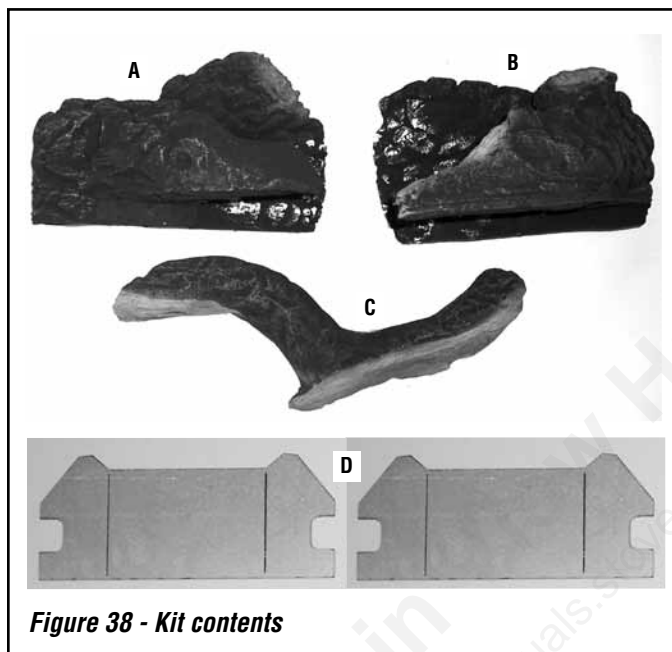

Figure 38 - Kit contents

Tools Required
None

CAUTION: The logs can be damaged if they are not handled with care!

To Install the log set:

1. Remove the two log support brackets (D) from the box and bend the ends of the brackets 90 degrees at the bend lines. See *Figures 39 and 40*.
2. One bracket goes into the left corner and the other into the right corner of the firebox. Rotate the brackets (D) so they are placed as shown in *Figure 40*. The bracket fits between the back of the firebox and the air wash at the front of the insert.
3. Remove the ceramic logs from the box and carefully unwrap them. Position each back log (A and B in *Figure 41*) in their proper place, one on each side against the back of the firebox.
4. The front log should face the front of the firebox with the wood grain showing. It should rest on the other two back logs. See *Figure 41* for assembled log set.

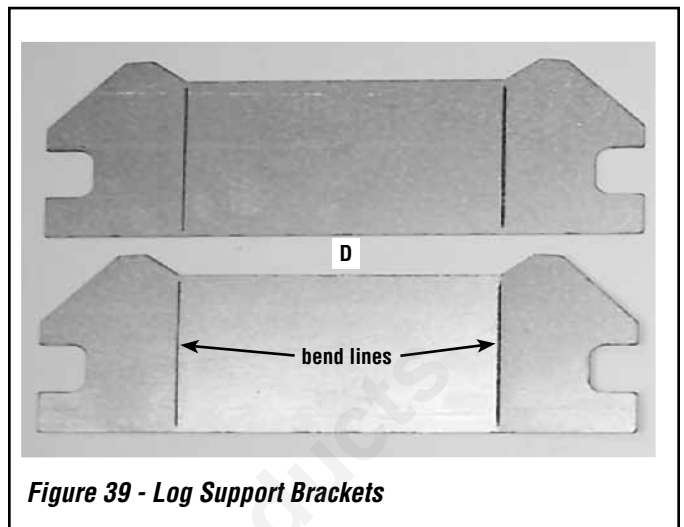

Figure 39 - Log Support Brackets

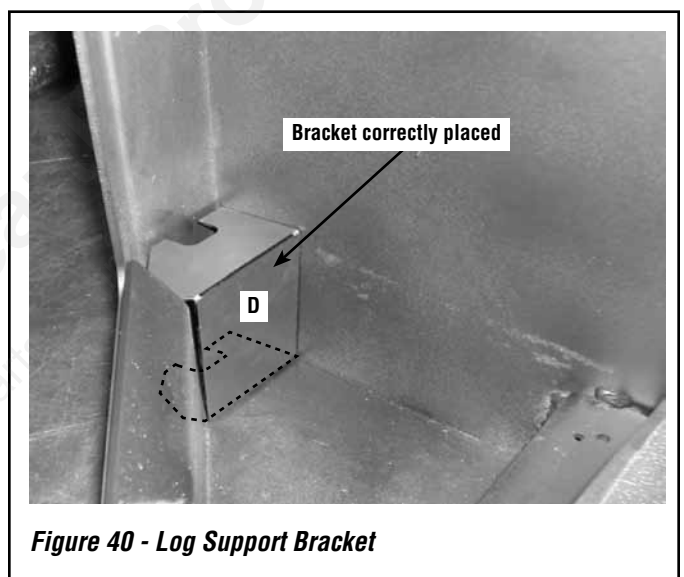

Figure 40 - Log Support Bracket

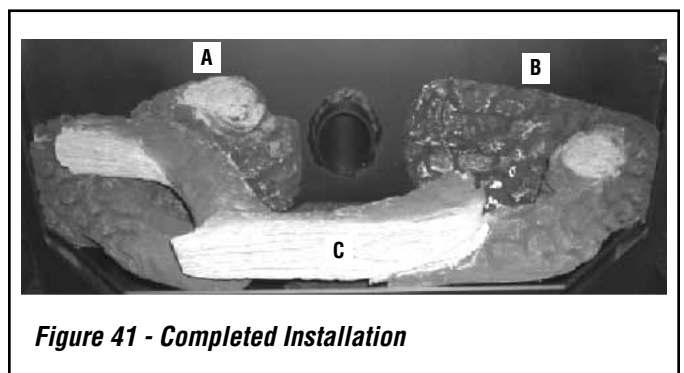

Figure 41 - Completed Installation

OPERATION

Control Board

The control board regulates all functions of the stove. The following is a list of the board's components:

- **Feeding light** - lights up when the auger is feeding pellets into the Burn-Pot.
- **Ready Light** - lights up when stove is ready to operate.
- **Igniting Light** - lights up when the stove is in the ignition sequence.
- **Start Button** - is pushed to start the ignition sequence after the heat selector knob is turned from off.
- **Heat Selector Knob** - is turned to off to shut the stove off or turned to a setting from 1 to high to regulate the burn rate.
- **Igniter Fuse** - six amp fuse to protect igniter heating element.
- **Control Fuse** - three amp fuse to protect the control board.

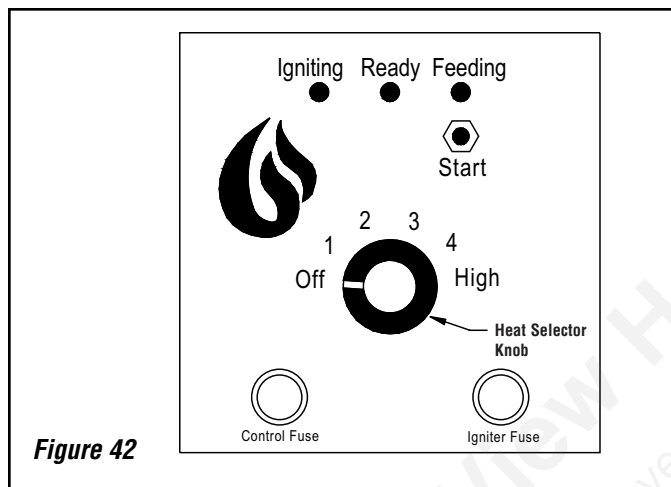

Filling the Hopper

The hopper can be accessed by lifting the lid at the rear of the top of the stove. The hopper will hold 60 pounds of pellets. Remove any contents from the hopper and fill with pellets as follows:

To fill the hopper when stove is off:

1. Lift the hopper lid to its full opened position.
2. Fill the hopper with pellets.
3. Check to make sure there are no remaining pellets on top of the hopper that may prevent the hopper lid from fully closing.
4. Close Hopper lid.

To fill the hopper when stove is in operation:

1. Repeat steps 1 thru 4 above.
2. When finished, check the burn pot to assure there is substantial combustion taking place to light the pellets once the pellets start feeding after refueling.
3. If combustion is not present in the burn pot then the unit will need to be restarted. This can be done by turning the heat setting dial to off and back to the desired heat setting 1 thru 5. You will then have to press the start button to initiate ignition.

CAUTION: Failure to confirm pellets in the Burn Pot remain burning after re-fueling may result in smoke escaping from the unit. Smoke escaping the unit can also be a result of ignition of the unit with excessive pellets located inside the burn pot.

Lighting

1. Turn the heat selector knob (see **Figure 42**) to the heat level desired - 1 through high - and the ready light will turn green.
2. Push the start button and the ignite and feeding lights will come on and the lighting sequence will begin. For about the next 15 minutes the stove will feed pellets cyclically into the Burn-Pot, the combustion blower will come on and the igniter will heat up. During this sequence, some smoke in the firebox is to be expected. After the igniting sequence is complete, the stove will begin burning at the level indicated by the heat selector knob.

NOTE: Upon the stove's initial light up, or if the stove has previously run out of pellets, the auger feed tube may not contain a sufficient number of pellets to allow the stove to continue burning after the ignition sequence. It may be necessary to push the start button a second time to run the start sequence again. It is important to always empty (when cool) the Burn-Pot of pellets before pushing the start button a second time.

! WARNING

- **Never empty pellets from the Burn-Pot into the hopper. Pellets that may appear to be cool may retain enough heat to ignite other pellets resulting in smoke or fire damage.**
- **DO NOT OVERFIRE THIS STOVE. This may cause serious damage to your stove and void your warranty. It also may create a fire hazard in your home. IF ANY EXTERNAL PART OF THE UNIT BEGINS TO GLOW, YOU ARE OVERFIRING. Immediately slide the knob to the "OFF" position on the control board.**

Manual Operation

After the stove is burning (see lighting above), the heat selector knob controls the pellet burn rate and the stove's heat output. Turning the knob to setting 1 allows the stove to burn about 1.8 pounds of pellets per hour - about 8,500 BTUs per hour. Turning the knob to high allows the stove to burn 4.7 pounds of pellets per hour - about 39,000 BTUs per hour. Once set, the stove will continue to burn at this rate until shut off.

Thermostat Operation

This stove will operate with a low voltage thermostat. See **Page 13** for instructions on installing the thermostat. Once installed, the thermostat will control the operation of the stove. Important: When connected to a thermostat, it is necessary to push the ignite button for the initial burn, when the electrical flow to the stove is interrupted, if the selector knob is turned to off (and then back on), or if the stove runs out of pellets and therefore shuts off. After the initial ignition sequence, when the thermostat calls for heat (the room temperature is less than the temperature set on the thermostat) and the heat selector knob is not in the off position, the stove will burn at the heat selector knob setting. The higher the setting, the quicker the room will heat up. Once the thermostat no longer calls for heat (the room is up to the desired temperature), the stove will continue to burn for one additional hour at the lowest setting. If the thermostat does not call for heat again during that hour, the stove will shut off. During that hour, if the thermostat calls for heat again, the stove will again burn at the heat selector knob setting until the thermostat no longer calls for heat. If the stove shuts off after that hour it will relight when the thermostat calls for heat.

Shut Down

Normal - To turn the stove off, turn the heat selector knob to off. The fans will continue to operate until the control board completes the shut down cycle.

Power Outage - If the stove loses electrical power for less than 10 seconds it will continue to operate. If the power loss is greater than 10 seconds, the stove will go into the ignition sequence and normal operation when the power is restored. If the stove is connected to a thermostat, the stove will not start the ignition sequence until the thermostat calls for heat.

Paint Curing

This stove has been painted with a high temperature metallic paint. It leaves the factory dry to the touch, but completes the curing process as the stove is used. The paint will cure during the first few times the stove is burned. Also some parts of the appliance may be lightly coated with machining oil. Ventilate the house during these first firings as the paint and oil give off carbon dioxide and unpleasant odors. It is recommended that persons sensitive to an imbalance in the indoor air quality avoid the stove during the curing process.

Convection Blower Operation

Your Winslow™ PS40 stove comes equipped with a temperature activated convection blower that extracts heat from the stove. After the stove warms up, a heat activated switch will turn the fan on. The speed of the fan varies with the burn rate of the stove. The fan will continue to extract heat after the stove shuts off and until it is cooled down.

Operating Sounds

As the Winslow PS40 stove is burning, a number of normal operational sounds may be heard. Pellets can be heard sliding down the auger tube and into the Burn-Pot. Also, the motor powering the auger can be heard as the control board calls for pellets. Occasionally a loud noise can be heard as the auger cuts a pellet in half. When the blowers come on, the sound of rushing air may be heard. The lower the burn rate the slower the fan operates. Hourly, the combustion blower will blow at a high speed to clean ash from the Burn-Pot.

Pellet Fuel

Pellet fuel is made from sawdust and scrap wood from many different species of wood. Pellets are either 1/4" or 5/16" in diameter and vary in length (see Fuel Specifications on **Page 6**). The Winslow PS40 stove will burn either diameter pellets. Pellets made from hardwoods contain more ash than those made from softwoods. Minerals from ash and sand in the pellets form clinkers under the extreme temperatures in the Burn-Pot. Try burning various brands of pellets until you find one that burns with minimum ash and clinkers.

Once you find a pellet brand that burns well, continue using this brand. High ash fuel increases the frequency of stove cleaning. Fuel with an excessive moisture content may jam the auger assembly.

Corn Fuel

Shelled corn can be burned in this appliance when it is mixed with wood pellet fuel (see Fuel Specifications on **Page 6**). The mixture can contain a maximum of 50 percent corn. Burning corn may create more ash than wood pellets and may necessitate the need to clean the Burn-Pot and glass more frequently.

CAUTIONS

INSTALLATION AND REPAIR SHOULD ONLY BE PERFORMED BY A QUALIFIED SERVICE TECHNICIAN. DO NOT ATTEMPT TO SERVICE THE APPLIANCE YOURSELF.

Avoid overfiring the stove - do not hand feed pellets to the appliance.

Never use gasoline, gasoline-type lantern fuel, kerosene, charcoal lighter fluid, or similar liquids to start or fresh up a fire in this heater. Keep all such liquids well away from the heater while it is in use.

For your safety, do not install or operate your Winslow PS40 stove without first reading and understanding this manual. Any installation or operation of the appliance deviating from that which is stated in this instruction manual WILL void the warranty and may be hazardous.

Due to high temperatures, the stove should be located out of traffic areas and away from furniture and draperies. Children and adults should be alerted to the hazards of high surface temperature and should stay away to avoid burns or clothing ignition. Young children should be carefully supervised when they are in the same room as the Winslow PS40 stove. Clothing or any other flammable material should not be placed on or near the stove. Any grill, panel, or glass removed for service MUST be replaced prior to operating the stove.

Do not operate appliance with the glass front removed, cracked, or broken. Replacement of the glass should be done by a qualified service technician.

IHP, its employees, or any of its representatives assume no responsibility for any damages caused by an inoperable, inadequate, or unsafe condition as a result of any improper operation, service, or installation procedures, whether direct or indirect.

The appliance, when installed, must be electrically grounded in accordance with local codes or, in the absence of local codes, with the National Electrical Code, ANSI/NFPA 70.

CLEANING AND MAINTENANCE

IMPORTANT CAUTIONS:

- **UNPLUG POWER CORD AND ENSURE APPLIANCE IS COLD BEFORE PERFORMING ANY MAINTENANCE WORK.**
- Some brands of pellets produce more ash and clinkers than others. Therefore the frequency of performing the following cleaning procedures depends to a great degree on the quality of the pellets burned.
- Not cleaning this unit will cause it to burn poorly and will void your warranty for this appliance.
- When removing ash build-up, use an approved ash vacuum only. A cleaning brush can be used to loosen any ash build-up before vacuuming. **DO NOT USE A STANDARD HOUSEHOLD VACUUM OR "SHOP VAC" AS THE FILTERS WILL LEAK THE FINE PARTICLES OF ASH INTO THE HOME.**
- **THIS WOOD HEATER NEEDS PERIODIC INSPECTION AND REPAIR FOR PROPER OPERATION. IT IS AGAINST FEDERAL REGULATIONS TO OPERATE THIS WOOD HEATER IN A MANNER INCONSISTENT WITH OPERATING INSTRUCTIONS IN THIS MANUAL.**

Required Cleaning Schedule After Number Of Bags Burned:

Burn-Pot = 10 bags
Ash Drawer = 20 bags
Flue passageways = 50 bags
Combustion Blower = 100 bags
Blower = 100 bags

NOTES:

- *Cleaning schedule will vary depending on quality of pellets used. Burning high ash pellets will require more frequent cleaning.*
- *Using a drop cloth is recommended as some ash may spill onto the floor during the cleaning process*

Burn-Pot Cleaning

(Recommended Frequency of 1 – 7 days*)

The combustion blower comes on at high speed once an hour to blow the by-products of combustion out of the Burn-Pot. However, the Burn-Pot should be cleaned more thoroughly after burning about 10 bags of pellets. The Burn-Pot has a number of holes in the bottom and sides that provide combustion air to the pellets. The extreme temperatures in the Burn-Pot can cause the impurities in the pellets to form ash and clinkers. When the stove is cool, open the front door and lift out the cast iron Burn-Pot. Scrape the inner bottom and sides of the pot with a screwdriver to remove all ash and clinkers from these surfaces. Make sure all the holes in the pot are open. Place the Burn-Pot in the hole from which it was removed. Make sure the high side of the pot is rotated toward the front of the stove (see **Figure 43**). Push the Burn-Pot down so surface A is tight against the steel supporting the pot. Do not substitute any other grate or pot for use in this stove.

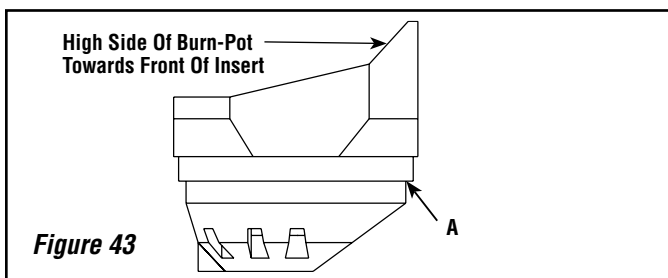

Cleaning Glass

CAUTION: Do not open the front door when the stove is hot. To open the door, follow the first two steps listed in Front Door Removal (see *Page 25*). Clean the glass using a soft cloth or paper towel and household glass cleaner or wood stove window cleaner. A commercial glass cleaner designed for stoves is recommended. Do not use abrasive cleaners. A damp cloth with a small amount of ash from the firebox can also be used to clean the glass.

CAUTION: BE CAREFUL NOT TO ABUSE THE DOOR ASSEMBLY BY STRIKING OR SLAMMING IT. IF THE DOOR ASSEMBLY OR GLASS IS BROKEN OR DAMAGED, THEY MUST BE REPLACED BEFORE HEATER CAN BE SAFELY OPERATED. USE ONLY COMPONENTS PROVIDED BY THE MANUFACTURER AS REPLACEMENT PARTS.

Ash Drawer Removal and Cleaning

(Recommended Frequency of 2 days to 2 weeks*)

CAUTION: Do not remove the ash drawer when the stove is hot. To remove the ash drawer, swing open the left and right side doors. Rotate the lever on latch B (see *Figure 44*) out from the stove to release the ash drawer. Do the same with the latch on the right side of the stove. Pull the ash drawer forward and away from the stove.

CAUTION: Disposal of Ashes - Ashes should be placed in a steel container with a tight fitting lid and moved outdoors immediately. The closed container should be placed on a non-combustible floor or the ground - well away from all combustible materials, pending final disposal. If the ashes are disposed of by burial in soil or otherwise locally dispersed, they should be retained in the closed container until all cinders have been thoroughly cooled.

Reinstall the ash drawer by inserting the drawer in the stove and refastening the left and right latches securely. Note that if the ash drawer does not seal tightly to the stove, the control board may detect a leak and shut the stove down.

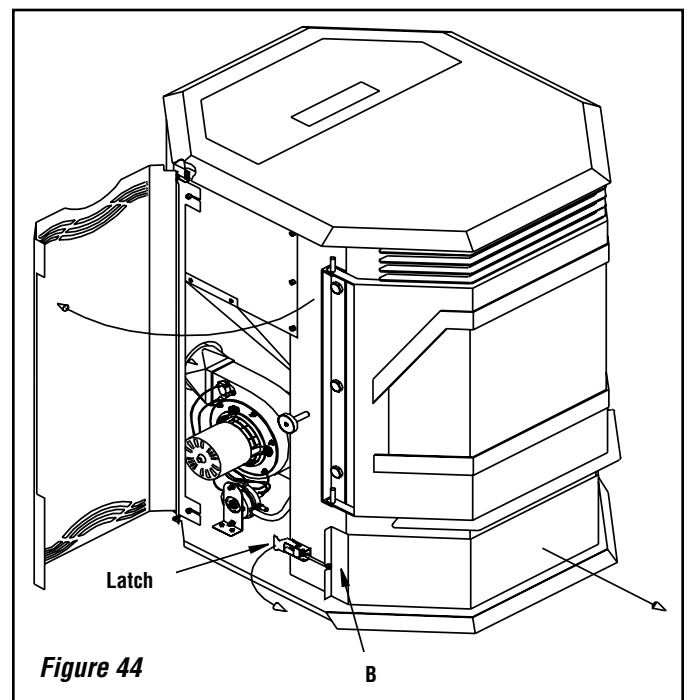

*Burning fuel with a high ash content or an improperly adjusted damper may require more frequent cleaning and stove maintenance.

Inspect Gaskets

Inspect the condition of the rope gasket around the door, window and ash drawer, periodically, and replace if necessary. Inspect the die-cut gaskets on the access covers (B and C in **Figure 45A**) and replace if necessary.

Cleaning the Heat Exchanger

(Recommended Frequency of 2 days to 2 weeks*)

CAUTION: Do not operate the heat exchange scraper when the stove is hot. Located at the center of the grill on the top front of the stove is a bent rod that is attached to a scraper on the heat exchange tubes. To remove ash build-up and maintain efficient heat extraction from the stove, this rod should be pulled in and out.

Cleaning the Flue Gas Passageways

(Recommended Frequency of Yearly*)

Cleaning the flue gas passageways should be done at least once a year. Burning high ash pellets may require this cleaning to be done more often. Clean these passageways only when the stove and ash are cold - do not start a fire in the vacuum cleaner by vacuuming up hot ash. On each side of the stove there are two access covers (see B and C in **Figure 47**) that can be removed by unscrewing the two 5/32" allen head screws. Insert a cleaning brush in the openings to loosen any ash build-up and use an approved ash vacuum cleaner to remove the loosened ash. Reinstall the covers when cleaning is complete.

There are also two more access holes located behind the ash drawer. Remove the ash drawer (see previous page) and loosen the two 5/16" screws with a 1/2" socket or wrench, the screws are shown as D in **Figure 46A and 46B on Page 24**. Rotate the covers over the access holes and use a brush and vacuum to clean the ash. Rotate the covers back over the holes and tighten the screws.



WARNING

DO NOT USE BRUSH ON HOT STOVE

Flue Passageways Cleaning Procedure

(Recommended Frequency of Yearly*)

1. Open both the right and left side door to locate side clean-out covers (see B and C in **Figure 45A**).
2. There is one upper and one lower, 1" x 2", clean-out covers on both the left and right sides (see B and C in **Figures 45A, 45B and 45C**).
3. Using a 5/32" allen remove allen head screws on each cover to access the flue passage way cavities.
4. Using an ash vac, clean out both flue passageways on both the left and right side of the stove starting at the top then going to the lower.
5. Once the flue passageways are clear of ash build-up, reinstall the four cover plates.
6. Remove the ash drawer (see **Figures 44**) to locate the lower left and right tear drop shaped flue passageways (see D in **Figures 46A and 46B**).
7. Using a 3/8" open end wrench or ratchet with 3/8" socket, loosen the screws at the top of each cover.
8. Rotate the clean-out covers off to the side to access the flue passage way cavity (see D in **Figure 46B**). Using an ash vac, clean out all ash build-up.
9. Rotate the covers back to original position and tighten the screws.

*Burning fuel with a high ash content or an improperly adjusted damper may require more frequent cleaning and stove maintenance.

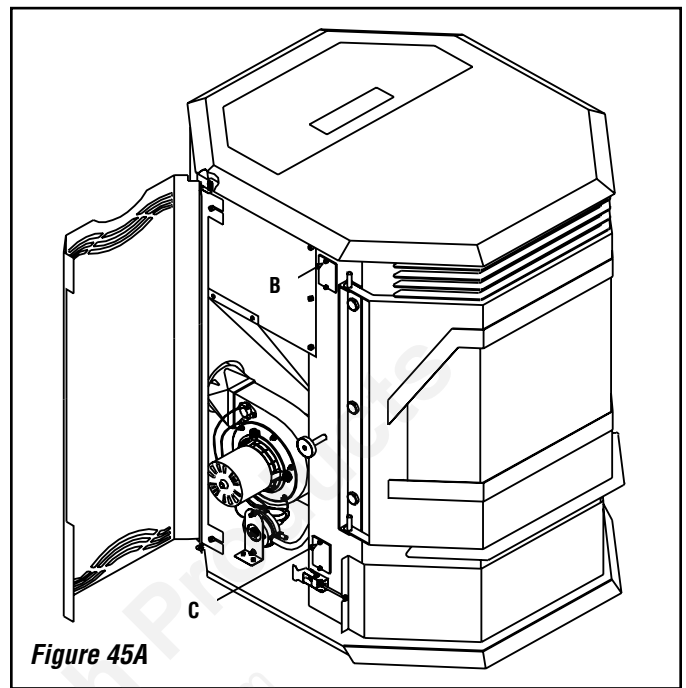

Figure 45A

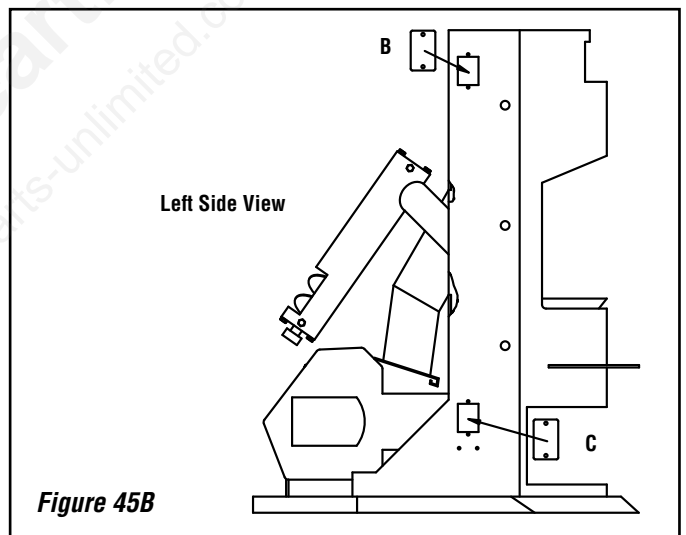

Figure 45B

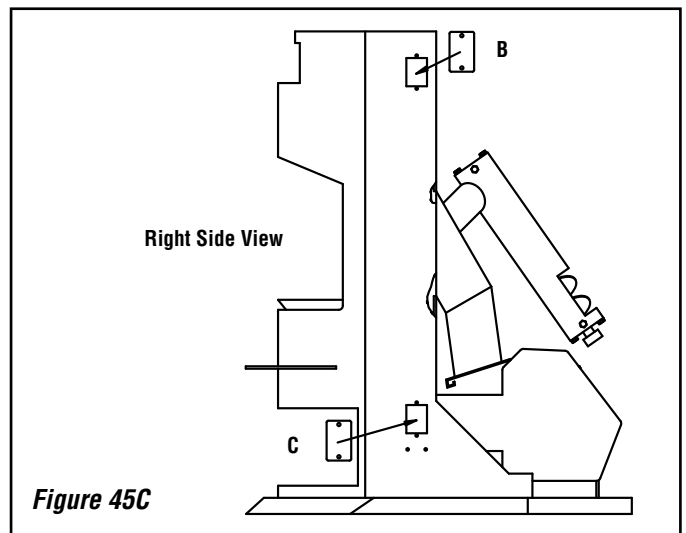

Figure 45C

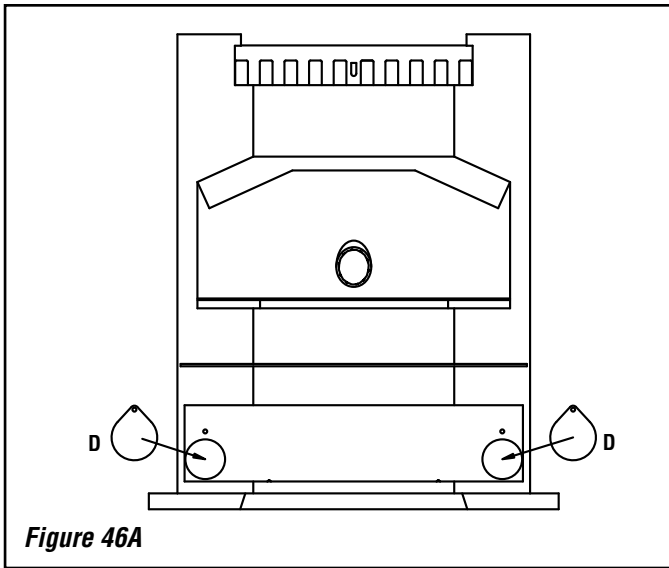

Figure 46A

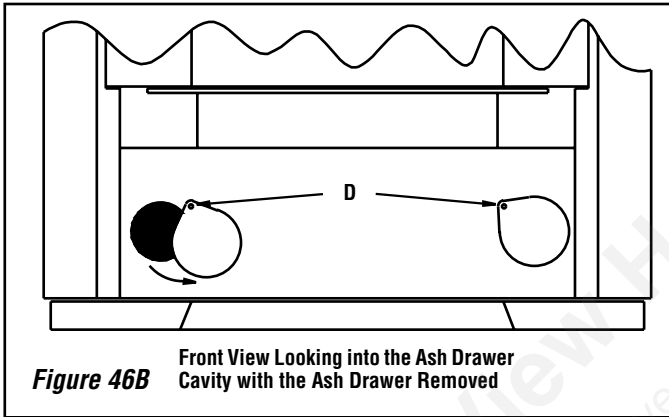

Figure 46B Front View Looking into the Ash Drawer Cavity with the Ash Drawer Removed

Cleaning the Combustion Blower

(Recommended Frequency of 1 year or after every 100 bags of fuel used*)

To clean the combustion blower, remove the six nuts labeled A in **Figure 47** with an 11/32" wrench. After removing these nuts, the motor with fan attached can be pulled from the fan housing. The fan blades and the fan housing can be vacuumed once the motor is removed. Before reinstalling, vacuum out the blower housing and flue passageway leading to the combustion blower. When reinstalling the motor, a new gasket may need to be installed between the motor and the fan housing. To complete the reinstallation, place the motor back on the fan housing and reinstall the six nuts. Make sure the motor's green ground wire is secured under one of the nuts.

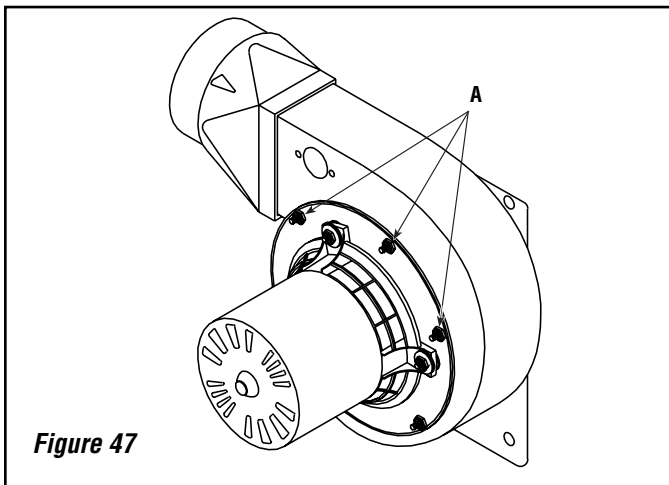

Figure 47

Cleaning the Vent Pipe

(Recommended Frequency of Yearly*)

Soot and Fly-Ash: Formation and Need for Removal - The products of combustion will contain small particles of fly-ash. The fly-ash will collect in the exhaust venting system and restrict the flow of the flue gases. Incomplete combustion, such as occurs during start-up, shutdown, or incorrect operation of the room heater will lead to some soot formation which will collect in the exhaust venting system. The exhaust venting system should be inspected at least once every year to determine if cleaning is necessary. Sweep the pipe as needed. A tee and clean-out in the vent system attached to the stove's flue collar will facilitate this cleaning.

Cleaning the Convection Blower

(Recommended Frequency of Yearly*)

To clean the convection blower, remove the right side door (see the following page). Disconnect the stove power cord from the electrical outlet. Using a 5/32" allen wrench loosen the two screws (A in **Figure 48**) securing the blower to the blower duct (loosen screws only - do not remove). Slide the blower to the rear - disengaging it from the blower duct. A vacuum can be used to remove any dust accumulation on the blower's blades or inside the blower duct. Caution should be used not to damage the blower's blades during cleaning. To reinstall the blower, slide the blower back into the retaining lip (B) and tighten screws (A).

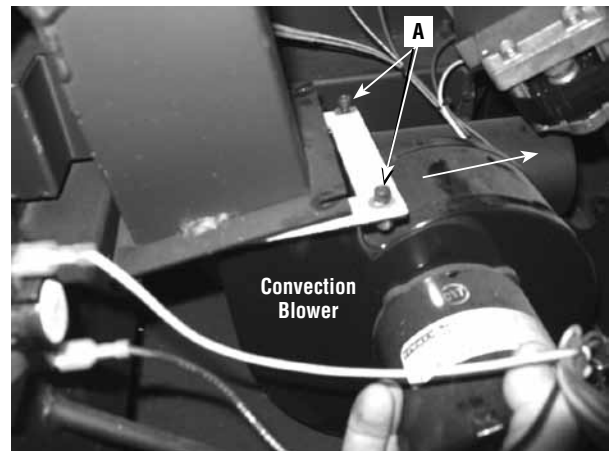
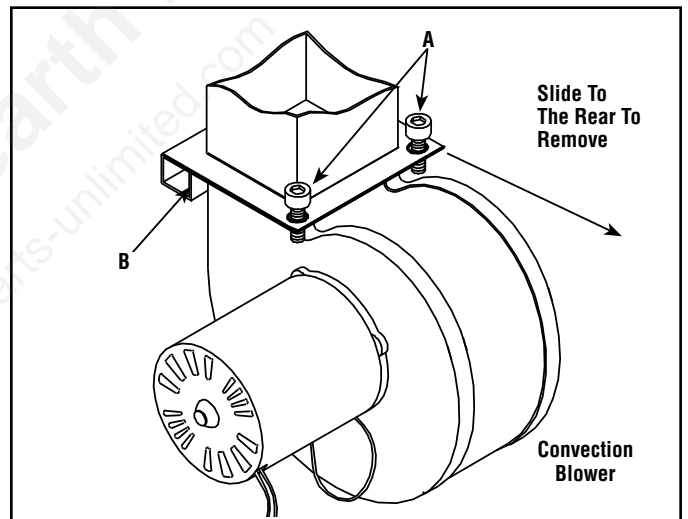

Figure 48

*Burning fuel with a high ash content or an improperly adjusted damper may require more frequent cleaning and stove maintenance.

Proof of Fire Switch

(Recommended Frequency of 1 year or after every 100 bags of fuel used*)

This switch needs to be removed and cleaned after every 100 bags of fuel burned.

Cleaning Procedure:

1. **UNPLUG STOVE!**
2. Locate the switch on the combustion blower (see **Figure 52**).
3. Using a flat-head screwdriver, remove the 2 screws which secures the switch to the blower housing.
4. Using a dry cloth, wipe off any flyash build-up on the sensor portion of the switch.
5. Reinstall switch. Ensure wires are properly connected to the switch and the connectors are not making contact with the blower housing. Close side panel.

NOTE: Failure to clean the proof of fire switch when needed may result in nuisance shut-downs. When heavy ash, creosote or soot are built up on the proof of fire switch, it may require cleaning with a medium abrasive pad or sheet. These heavy build ups insulate the heat sensing area of the switch and keep the switch from functioning as intended.

Front Door Removal

CAUTION: Do not open the front door when the stove is hot.

To remove the door, swing the left and right side doors A open. Pull the front door handle B to the front and swing the front door open. Lift the front door up and off the hinges as shown in C in **Figure 49**. To reinstall the door repeat the steps in reverse order.

Side Door Removal

To remove the door,

- 1 Swing the door open,
- 2 Lift the door up and
3. Pull the bottom of the door out and down - pulling the top hinge pin out of the retaining hole in the top hinge bracket.

To reinstall the door, slide the pin on the top of the door up and into the hole in the upper hinge bracket. Slide the pin on the bottom of the door into the hole in the pedestal base and rotate the door closed.

Back Removal and Lower Cover Plate

To remove the back:

1. Remove the left and right side panels (see the previous page).
2. If the stove is connected to the vent pipe, loosen the four 5/32" allen head screws (see A in **Figure 51**) securing the lower cover plate beneath the flue outlet, lift the plate slightly and pull the plate off.
3. Loosen the two screws B and C shown in **Figure 52** and the corresponding two screws on the other side of the stove. The back can now be pulled to the rear and off of the stove.

To reinstall the back, follow the steps just listed - but in the reverse order.

*Burning fuel with a high ash content or an improperly adjusted damper may require more frequent cleaning and stove maintenance.

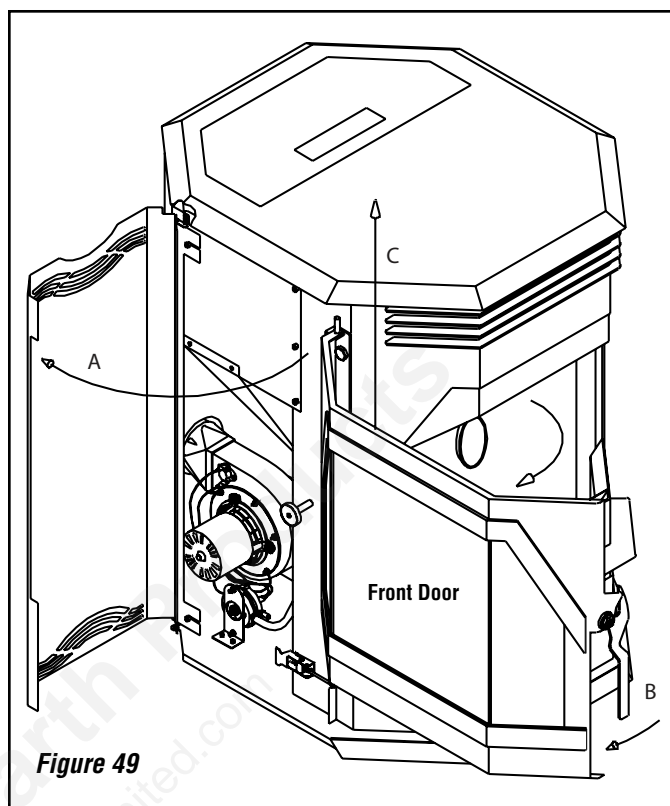

Figure 49

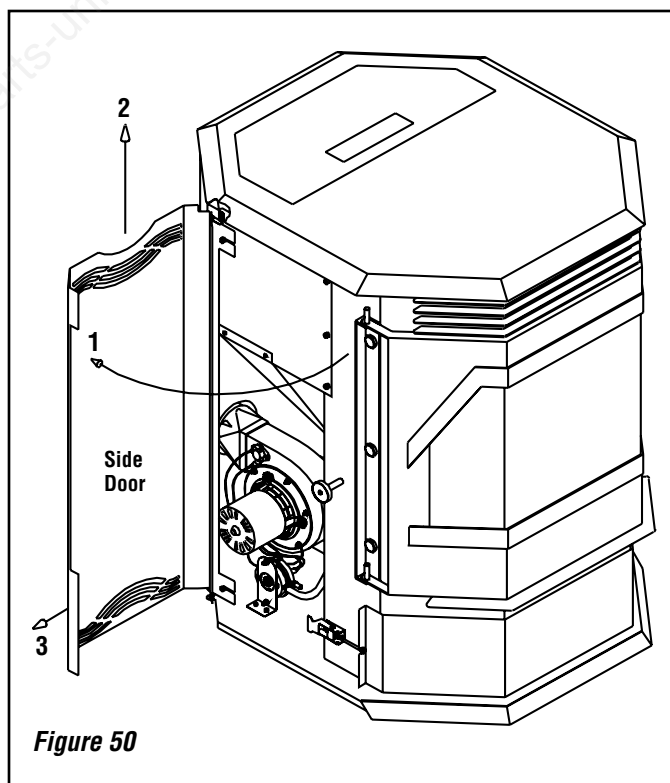

Figure 50

COMPONENT INFORMATION

The following is a list of components and their functions.

Igniter

The Winslow™ PS40 stove comes equipped with an automatic igniter for lighting the fuel when the stove is in the lighting mode. The igniter superheats air that is pulled through the Burn-Pot by the combustion blower to light the fuel. The igniter remains energized for the first seven minutes of the lighting sequence.

Vacuum Switch

The Winslow PS40 stove has a vacuum switch located behind the left door, fastened to the pedestal base (see D in **Figure 52**). If a low pressure is created in the firebox by a leak, opening the front door, a blocked flue, or unsealed ash drawer, the vacuum switch will sense it and cause the stove to go into a shutdown mode.

Auger and Auger Motor

The 1.25 RPM auger motor turns the auger, lifting pellets up the auger tube. The pellets are then dropped down a tube and into the burn-pot. The auger is controlled by the control board.

Over Temperature Snap Switch (Manual Reset)

(Opens at 225°F) This switch is installed on the convection blower (see F in **Figure 53**) and shuts the stove down if it senses excessive temperatures. This snap switch has a reset button on it and will not allow the stove to start up until the reset button has been pushed.

Proof of Fire Snap Switch

(Closes at 140°F) This switch is installed on the combustion blower (see E in **Figure 52**) and shuts the stove down if it senses no fire in the Burn-Pot.

Convection Blower Snap Switch

(Closes at 120°F) This switch is installed on the right rear of the firebox and turns the convection blower on when the stove gets up to temperature.

Hopper Lid Switch

It is located on the back right side of the hopper (on the outside of the hopper). It detects whether the hopper lid is open and will turn off the auger motor if the hopper lid is not properly closed. When opening the hopper when refueling, do not allow the hopper lid to remain open too long or the fire may extinguish. **NEVER DISCONNECT OR BYPASS THIS SWITCH FOR ANY REASON.**

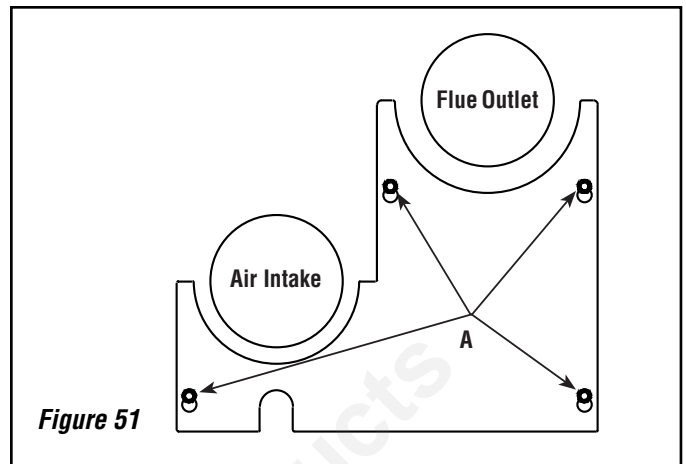

Figure 51

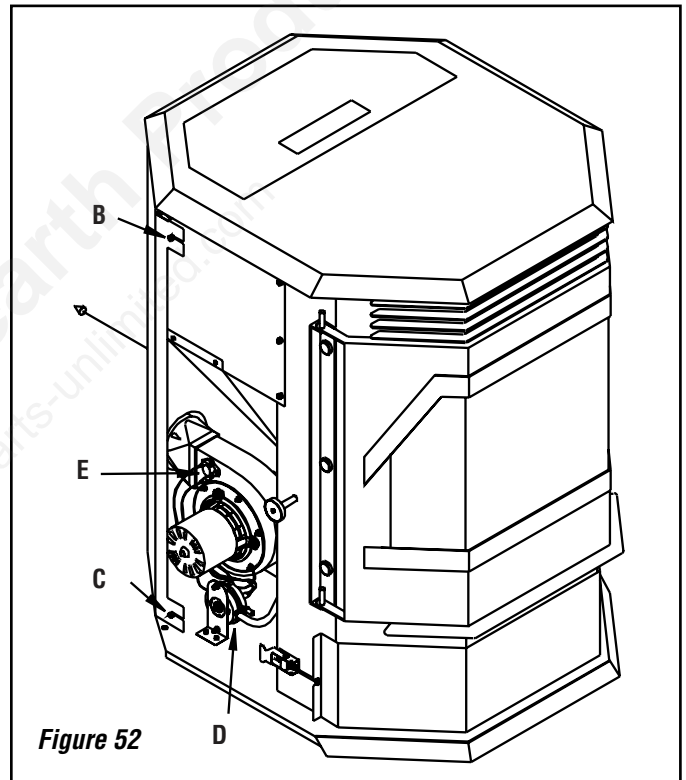

Figure 52

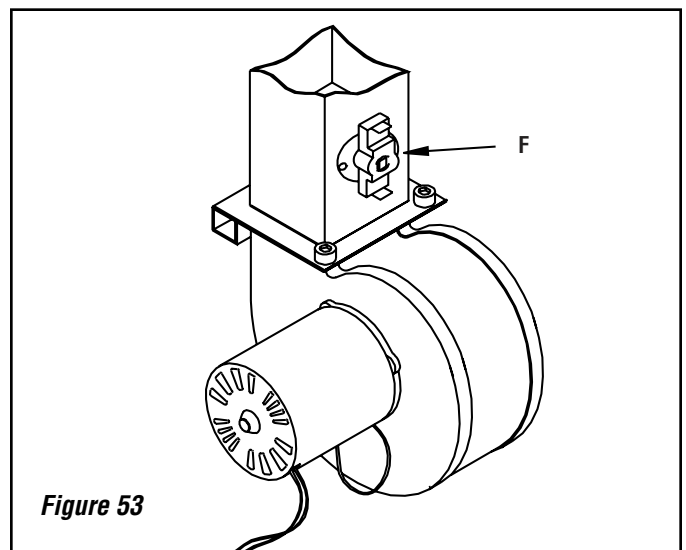

Figure 53

Draft Adjuster - Adjustment Procedure

The Winslow™ PS40 stove has a draft adjuster located at the left side of the stove directly in front of the combustion blower. Should the stove installation require long runs of vent pipe, a situation may be created where excessive combustion air is flowing through the firebox and causing the fuel to burn faster than it can be delivered to the Burn-Pot. Should this happen, the draft can be slowed down by the adjuster. The stove is shipped with the adjuster in the fully open position. To slow the draft down, loosen the 5/32" allen head screw (A in **Figure 54**) and move the adjuster handle toward the center of the stove. Retighten the screw when the desired adjustment is reached.

Draft Adjuster

The draft adjuster controls the amount of combustion air that is delivered to the firebox (see **Figure 54**).

It will be necessary to monitor the appearance of the flame during the first 4-8 bags of pellets. If the flame is smoky red or orange with evidence of soot at the top of the flame, the draft adjuster will need to be adjusted to deliver more combustion air. If the flame is "short" at the higher burn rates, and appears to burn the pellets out of the pot faster than they can be resupplied, or there are significant variations of flame height within a single burn setting, the draft adjuster may need to be adjusted to deliver less combustion air.

After the draft adjuster is adjusted, re-evaluate the appearance of the flame. It may be necessary to continue adjusting it in increments until proper combustion is achieved (the flame should become a brighter yellow and begin to "dance").

Once the draft adjuster has been properly set, and if the routine maintenance is performed as needed, the draft adjuster should not require readjustment unless you are changing from a premium grade pellet to a standard or high ash pellet, in which case the draft adjuster may need to be moved outward from center of the stove to help prevent the accumulation of ash or clinkers in the Burn-Pot.

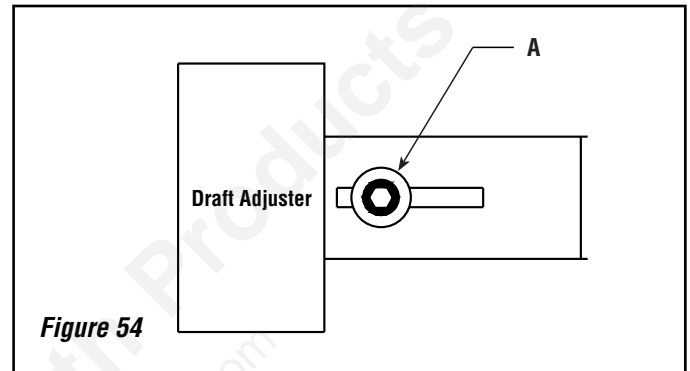

Figure 54

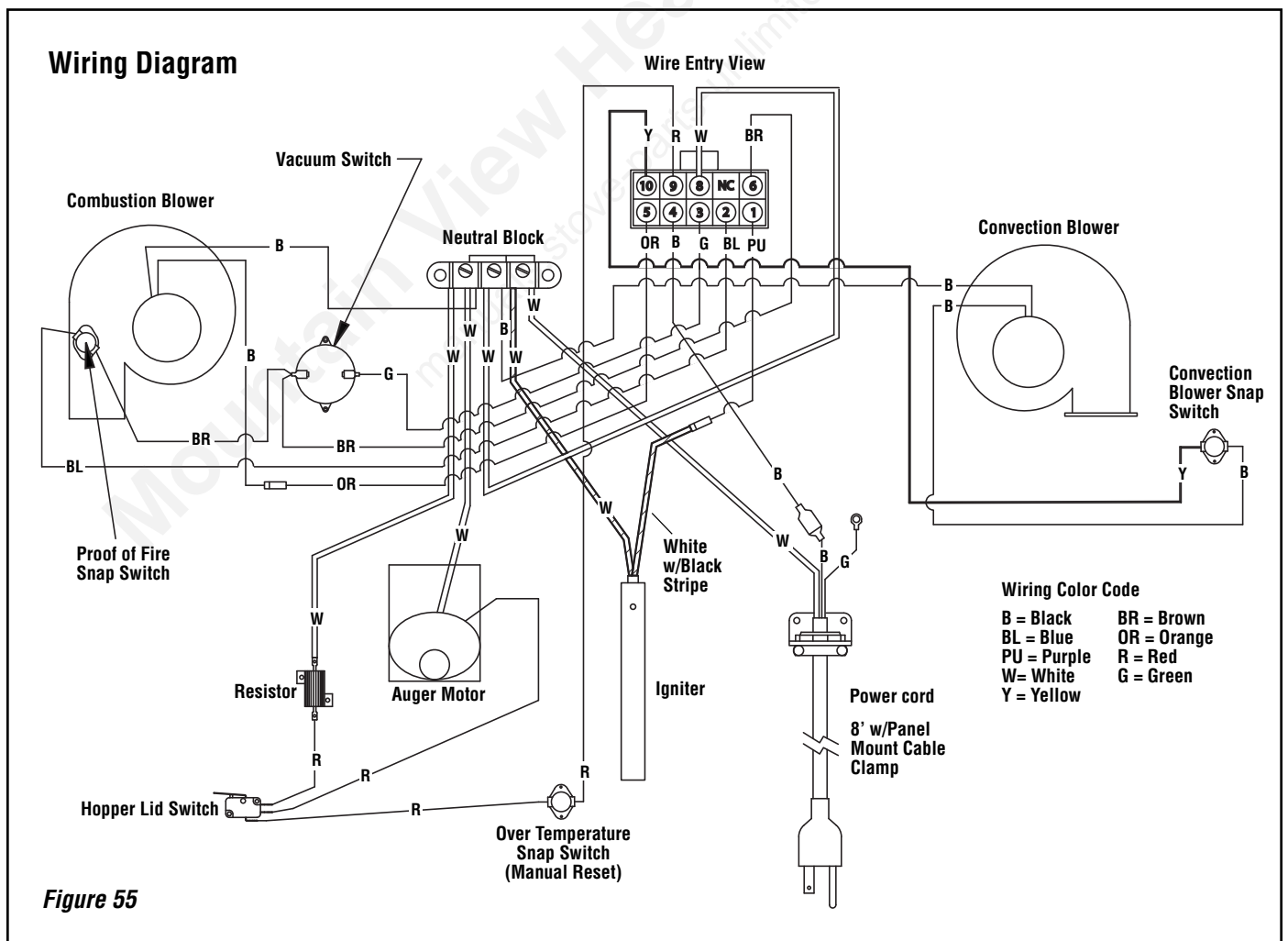

Figure 55

NOTE: DIAGRAMS & ILLUSTRATIONS ARE NOT TO SCALE.

DIAGNOSTIC CODES

If the stove operates abnormally, the ready light on the control board will signal the nature of the abnormal operation. The following is a list of possible signals or codes:

Ready light is constant red
 Ready light flashes red 1 short and 1 long blink
 Ready light flashes red 2 short blinks
 Ready light flashes red 2 long blinks

Ignition Failure
 Vacuum Switch Open
 Proof of Fire Snap Switch Open
 Over Temperature Snap Switch Open

Troubleshooting

Ignition Failure - Code - Ready light is constant red and ignite light flashes two short blinks	
Possible Problem	Solution
Hopper is out of pellets	Fill the hopper with pellets
Auger tube was not full of pellets when start button was pushed	When cool, empty pellets in Burn-Pot and push start button again
Burn-Pot dirty - holes plugged	Clean the Burn-Pot
Igniter not functioning	Replace the igniter
Igniter fuse blown	Replace 6 amp fuse located on front of the control board

Control Board has no Power - When selector knob is turned no lights light up	
Possible Problem	Solution
Power cord is not plugged in	Plug in power cord
Board fuse blown	Replace 3 amp fuse located on front of control board
Wall outlet not energized	Check circuit breaker panel
Board broken, damaged, or defective	Replace the control board

Vacuum Switch Shuts Stove Down - Code - Ready light flashes red 1 short and 1 long blink	
Possible Problem	Solution
Front door is not sealing	Latch or adjust the front door or replace door gasket
Ash drawer is not sealing	Close latches, adjust latches, or replace drawer gaskets
Flue gas passageways restricted	Clean the passageways (see Page 23)
Vent pipe restricted	Clean the vent pipe (see Page 24)
Vacuum hose plugged	Clean or replace the vacuum hose
Vacuum switch defective	Replace the vacuum switch

Proof of Fire Snap Switch Shuts Stove Down - Code - Ready light flashes red 2 short blinks	
Possible Problem	Solution
Hopper is out of pellets	Fill the hopper with pellets
Auger tube was not full of pellets when start button was pushed	When cool, empty pellets in Burn-Pot and push start button again
Snap switch* defective	Replace the snap switch
"Proof of fire" switch is dirty	Clean switch per instructions on Page 25

Over Temperature Snap Switch Shuts Stove Down - Code - Ready light flashes red 2 long blinks

Possible Problem	Solution
Convection blower not running	Blower dirty, blower snap switch bad, or blower broken
Flue passageways or vent restricted	Clean passageways or vent pipe (see Pages 23 and 24)
Snap switch* defective	Replace the snap switch*

* **NOTE: The snap switch has a reset button that must be pushed before stove will function (see Page 26).**

Orange Sooty Flames - Glass Turns Black

Possible Problem	Solution
Burn-Pot is dirty	Clean the Burn-Pot
Vent pipe restricted	Clean the vent pipe
Flue gas passageways restricted	Clean the passageways
Combustion blower dirty	Clean the combustion blower
Burning improper fuel	Burn only wood pellet fuel or corn fuel that meets the fuel specifications outlined on Page 6

Pellets Not Feeding

Possible Problem	Solution
Hopper empty	Fill the hopper
Auger jammed	Call service technician
Flue gas passageways restricted	Call service technician
Auger motor not operating	Call service technician
Hopper lid is open	Close Hopper Lid
Hopper lid switch is faulty	Replace hopper lid switch if determined to be faulty

REPLACEMENT PARTS - WINSLOW™ PS40

Contact an IHP dealer to obtain any of these parts. Never use substitute materials. Use of non-approved parts can result in poor performance and safety hazards.

Cat. No.	Description		
H6006	Adjustable Latch Pin	H6037	Flue Restrictor W/hardware
H3111	Ash Clean Out Cover, 2 Per Stove	H5911	Hopper Door Wire
H3113	Ash Drawer	79021	Igniter Fuse 6amp, 5pk
H5912	Ash Drawer Latch W/hardware 2 Per Stove	H6005	Igniter W/hose Clamp
H5886	Auger Motor	H5891	Overtemp Switch
H5921	Auger W/lower Bearing	H5660	Power Cord
H5875	Blower Snap Switch	H5887	Proof Of Fire Switch
H5856	Cast Burn-Pot	H3114	Side Ash Cover Clean Out
H5899	Clean-out Cover Gasket	H6174	Side Door, Left
H6018	Combustion Blower	H5916	Side Door Magnet
H5900	Combustion Gasket Housing To Stove	H5833	Side Door W/control Access, Right
H5903	Combustion Gasket Motor To Housing	H5832	Stove Back
H5917	Control Board Access Latch	H6035	Stove Back Cover Plate
H5978	Control Board	H6036	Top Side Door Bracket, Right
79020	Control Board Fuse 3amp, 5pk	H6175	Top Side Door Bracket, Left
H5884	Convection Blower	H5898	Vacuum Line 12" Piece
H5902	Convection Blower Gasket	H5889	Vacuum Switch
H5904	Door Gasket 1 Ft (7ft Per Door)	H5892	Wiring Harness
H3112	Door Handle Assembly	H8276	Hopper Switch w/ Bracket
79040	Door W/glass (No Trim)	H8277	Hopper Switch Wires w/ Resister
		H8280	Outer Top For Hopper Lid Switch

ACCESSORIES

Door Trim (required - sold separately) (ref. Form # 775274M)

Item No.	Cat. No.	Model	Description
1	79038	P40DT-B	Black
2	79034	P40DT-G	Gold
3	79037	P40DT-N	Nickel
4	79035	P40DT-BRN	Brushed Nickel
5	79036	P40DT-BLN	Black Nickel

Grill Kits (required - sold separately) (ref. Form # 775273M)

Item No.	Cat. No.	Model	Description
6	79000	P40G-B	Black
7	79001	P40G-G	Gold
8	79002	P40G-N	Nickel
9	79022	P40G-BN	Brushed Nickel
10	79039	P40G-BLN	Black Nickel

NOTE: The form numbers referenced are the part numbers of the instruction sheets included in kits.

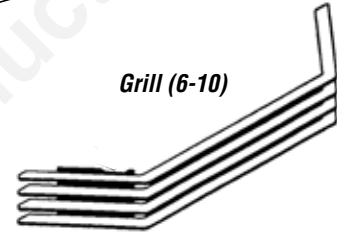
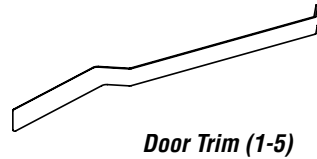

Mountain View Hearth Products
manuals.stove-parts-unlimited.com

ACCESSORIES

Common Accessories

Item#	Cat. No.	Model	Description
11	H5142	P40LOG	Log Set (ref. Form # 775275M)
12	79030	P40BRICK	Brick Panel (ref. Form # 775276M)
13a	H8860	RC-S-1	Remote, Two Button, Timer, On/Off or Timer Mode
13b	H8861	RCL-S-STAT	Remote, LCD Stat, Thermostat, On/Off
13c	H8865	RC-S-TOUCH	Remote, Touch Screen, Thermostat, On/Off
13d	H8840	KIT-RC-G-FIRE	Remote, Simple On/Off
14a	H8863	WS-S-TMR	Wall Switch, Countdown Timer
14b	H8864	WS-S-TSTAT	Wall Switch, Thermostat
15	H6907	P40DIAG	Diagnostic Tool (ref. Form # 775293M)
16	12050004	-----	Cleaning Brush (ref. Form # 14720036)
17	H8159	TSPK - B	Touch-up Paint Kit, Metallic Black, 12 oz Spray Can

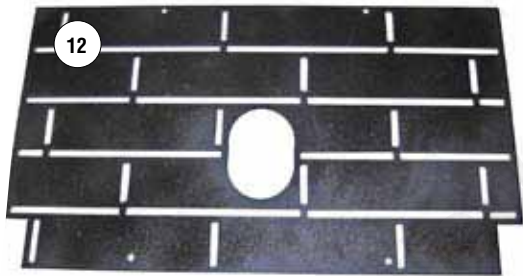
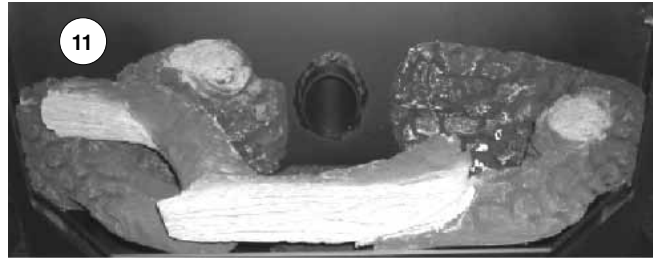

15



16



17



13a



13b



13c



13d



14a



14b

Innovative Hearth Products IronStrike™ Pellet Stove and Insert Limited Lifetime Warranty

THE WARRANTY

Innovative Hearth Products ("IHP") Limited Lifetime Warranty warrants your IronStrike™ brand pellet fueled stove or insert ("Product") to be free from defects in materials and workmanship at the time of manufacture. The Product body, heat exchange tubes and ceramic glass carry the Limited Lifetime Warranty. Ceramic glass carries the Limited Lifetime Warranty against thermal breakage only. After installation, if covered components manufactured by IHP are found to be defective in materials or workmanship during the Limited Lifetime Warranty period and while the Product remains at the site of the original installation, IHP will, at its option, repair or replace the covered components. If repair or replacement is not commercially practical, IHP will, at its option, refund the purchase price or the wholesale price of the IHP Product, whichever is applicable.

IHP will also pay IHP prevailing labor rates, as determined in its sole discretion, incurred in repairing or replacing such components for up to five years. THERE ARE EXCLUSIONS AND LIMITATIONS to this Limited Lifetime Warranty as described herein.

COVERAGE COMMENCEMENT DATE

Warranty coverage begins on the date of installation. In the case of new home construction, warranty coverage begins on the date of first occupancy of the dwelling or six months after the sale of the Product by an independent IHP dealer/distributor, whichever occurs earlier. The warranty shall commence no later than 24 months following the date of product shipment from IHP, regardless of the installation or occupancy date.

EXCLUSIONS AND LIMITATIONS

This Limited Lifetime Warranty applies only if the Product is installed in the United States or Canada and only if operated and maintained in accordance with the printed instructions accompanying the Product and in compliance with all applicable installation and building codes and good trade practices.

This warranty is non-transferable and extends to the original owner only. The Product must be purchased through a listed supplier of IHP and proof of purchase must be provided. The Product body and heat exchange tubes carry the Limited Lifetime Warranty from the date of installation. Vent components, trim components and paint are excluded from this Limited Lifetime Warranty. The following do not carry the Limited Lifetime Warranty but are warranted as follows:

- Accessories** – Repair or replacement for 90 days from the date of installation
- Cast iron burn pot** - Replacement for five years from the date of installation
- Electrical components** – Repair or replacement for two years from the date of installation
- Firebrick/refractory** – Replacement for 90 days from the date of installation
- Gaskets** – Repair or replacement for one year from the date of installation
- Gold & nickel plating** - Replacement for two years from date of installation. Excludes tarnishing
- Steel burn grate** - Replacement for two years from the date of installation
- Logs** – Replacement for 90 days from the date of installation
- Labor** – Prevailing IHP labor rates apply for the warranty period of the component

Parts not otherwise listed carry a 90 day warranty from the date of installation.

Whenever practicable, IHP will provide replacement parts, if available, for a period of 10 years from the last date of manufacture of the Product.

IHP will not be responsible for: (a) damages caused by normal wear and tear, accident, riot, fire, flood or acts of God; (b) damages caused by abuse, negligence, misuse, or unauthorized alteration or repair of the Product affecting its stability or performance (The Product must be subjected to normal use. The use of fuels other than those outlined in the operation manual provided with the Product will void all warranties and liabilities.); (c) damages caused by failing to provide proper maintenance and service in accordance with the instructions provided with the Product; (d) damages, repairs or inefficiency resulting from faulty installation or application of the Product.

This Limited Lifetime Warranty covers only parts and labor as provided herein. In no case shall IHP be responsible for materials, components or construction which are not manufactured or supplied by IHP or for the labor necessary to install, repair or remove such materials, components or construction. Additional utility bills incurred due to any malfunction or defect in equipment are not covered by this warranty. All replacement or repair components will be shipped F.O.B. from the nearest stocking IHP factory.

LIMITATION ON LIABILITY

It is expressly agreed and understood that IHP's sole obligation and the purchaser's exclusive remedy under this warranty, under any other warranty, expressed or implied, or in contract, tort or otherwise, shall be limited to replacement, repair, or refund, as specified herein.

In no event shall IHP be liable for any incidental or consequential damages caused by defects in the Product, whether such damage occurs or is discovered before or after repair or replacement, and whether such damage is caused by IHP's negligence. IHP has not made and does not make any representation or warranty of fitness for a particular use or purpose, and there is no implied condition of fitness for a particular use or purpose.

IHP makes no expressed warranties except as stated in this Limited Lifetime Warranty. The duration of any implied warranty is limited to the duration of this expressed warranty.

No one is authorized to change this Limited Lifetime Warranty or to create for IHP any other obligation or liability in connection with the Product. Some states and provinces do not allow the exclusion or limitation of incidental or consequential damages, so the above limitations or exclusions may not apply to you. The provisions of this Limited Lifetime Warranty are in addition to and not a modification of or subtraction from any statutory warranties and other rights and remedies provided by law.

INVESTIGATION OF CLAIMS AGAINST WARRANTY

IHP reserves the right to investigate any and all claims against this Limited Lifetime Warranty and to decide, in its sole discretion, upon the method of settlement.

To receive the benefits and advantages described in this Limited Lifetime Warranty, the appliance must be installed and repaired by a licensed contractor approved by IHP.

Contact IHP at the address provided herein to obtain a listing of approved dealers/distributors. **IHP shall in no event be responsible for any warranty work done by a contractor that is not approved without first obtaining IHP's prior written consent.**

HOW TO REGISTER A CLAIM AGAINST WARRANTY

In order for any claim under this warranty to be valid, you must contact the IHP dealer/distributor from which you purchased the product. If you cannot locate the dealer/distributor, then you must notify IHP in writing. IHP must be notified of the claimed defect in writing within 90 days of the date of failure. Notices should be directed to the IHP Warranty Department at 1508 Elm Hill Pike, Suite 108; Nashville, TN 37210 or visit our website at WWW.IRONSTRIKE.US.COM.

WARRANTY

Your pellet stove is covered by a limited warranty (provided with appliance). Please read the warranty to be familiar with its coverage.

Retain this manual. File it with your other documents for future reference.

PRODUCT REFERENCE INFORMATION

We recommend that you record the following important information about your fireplace. Please contact your IHP dealer for any questions or concerns.

REPLACEMENT PARTS

See **Page 30** for a complete replacement parts list. Use only parts supplied from the manufacturer.

Normally, all parts should be ordered through your IHP distributor or dealer. Parts will be shipped at prevailing prices at time of order.

When ordering repair parts, always give the following information:

1. The model number of the appliance.
2. The serial number of the appliance.
3. The part number.
4. The description of the part.
5. The quantity required.
6. The installation date of the appliance.

If you encounter any problems or have any questions concerning the installation or application of this system, please contact your dealer.

IHP
1508 Elm Hill Pike, Suite 108
Nashville, TN 37210
visit us at IronStrike.us.com

Model Number _____
Serial Number _____
Date Installed _____
Dealer's Name _____
Dealer's Phone Number _____

NATIONAL FIREPLACE INSTITUTE

CERTIFIED
www.nficertified.org

We recommend that our pellet hearth products be installed and serviced by professionals who are certified in the U.S. by the National Fireplace Institute® (NFI) as NFI Pellet Specialists or who are certified in Canada by Wood Energy Technical Training (WETT).

 **Wood Energy Technical Training**
www.wettinc.ca

NATIONAL FIREPLACE INSTITUTE

CERTIFIED
www.nficertified.org

Nous recommandons que nos p eles   boulettes soient install es et que l'entretien soit effectu  par des professionnels certifi s, aux Etats-Unis par le National Fireplace Institute® (NFI), et au Canada par le Wood Energy Technical Training (WETT).

 **Wood Energy Technical Training**
www.wettinc.ca

IHP reserves the right to make changes at any time, without notice, in design, materials, specifications, and prices, and also to discontinue colors, styles, and products. Consult your local distributor for fireplace code information.

