

# MAGNUM WINCHESTER

## Corn/Biomass/Stove

### Models: WIN-ACP (Elite Board) & WIN-ACI, Owner's Manual

#### Installation – Operation – Maintenance Instructions

**NOTE: THESE INSTRUCTIONS MUST BE SAVED for future reference**

**PLEASE READ THIS ENTIRE MANUAL BEFORE INSTALLATION AND USE OF THIS PELLET BURNING STOVE. FAILURE TO FOLLOW THESE INSTRUCTIONS MAY RESULT IN PROPERTY DAMAGE, BODILY INJURY OR EVEN DEATH.**

**IMPORTANT:** Always contact your local Magnum dealer/installer with questions before contacting the factory. When you call, have your serial number, purchase date, who installed the unit and a list of questions.

- ✓ When installing your **Magnum Winchester (WIN) Corn/Biomass** stove, particular attention needs to be made in regards to fire protection. If the unit is not properly installed, a house fire may result. For your safety, follow the installation and operation instructions provided, and if a question arises contact local building or fire officials about restrictions and installation requirements in your area.
- ✓ Read the operations and fuel section of this manual before plugging in your unit.
- ✓ Always unplug the unit before attempting any service work.
- ✓ Do not connect the unit to a chimney flue already serving another appliance.
- ✓ When installing the chimney pipe to the unit, it is important to remember that the unit operates on a negative pressure and the chimney on a positive pressure. All chimney connections, elbows and fittings must be airtight. **(Proper venting practices must be followed. Consult with a venting professional)**
- ✓ Ashes must be disposed of in a metal container with a tight fitting lid.
- ✓ All minimum clearances to combustibles must be followed.
- ✓ The **Magnum Corn/Biomass Stove** is tested for operation with Biomass pellets, with an ash content of no more than 2% and Corn with a moisture content from 10-14 percent. **It is recommended that Biomass Fuel with an ash content of 1% or less be used for efficient operation of this unit. Higher ash content fuels will require additional maintenance and service. Corn with 11-12 percent moisture is ideal.**
- ✓ **It is important to use fuel that is clean, dry and consistent.** Make sure that your supplier is giving you the same fuel each time that you purchase. It is recommended that you purchase your entire heating season supply of fuel at one time so that the fuel will be the same.
- ✓ **A voltage surge protector or ground fault outlet is required for this unit. The electrical component warranty will be voided if surge protection is not installed before operating this unit.**
- ✓ **A grounded outlet must be provided with proper polarity. A constant 120 volt (12volt on DC models), 60 cycles must be provided for proper operation or the warranty of this appliance will be forfeited.**
- ✓ **Special attention needs to be taken to clean out the top heat exchangers of this unit on a regular basis. The fly ash settles on the heat exchangers and must be cleaned off to keep the unit operating properly. Check for plugging every two-four weeks or when needed.**
- ✓ **If unit is not operated for extended periods of time (like summer) unplug the unit and disconnect the battery to assure long life of electrical components.**

**AMERICAN ENERGY SYSTEMS, INC. GRANTS NO WARRANTY, IMPLIED OR STATED, FOR THE INSTALLATION OR MAINTENANCE OF THE STOVE AND ASSUMES NO RESPONSIBILITY FOR ANY CONSEQUENTIAL DAMAGE(S).**

AMERICAN ENERGY SYSTEMS, INC. - 150 Michigan Street SE - HUTCHINSON, MINNESOTA 55350

Web Site: [www.Magnumheat.com](http://www.Magnumheat.com)

date 12/31/2015 rev.

**SECTION****PAGE**

Introduction/Specifications.....	3
Technical Bulletin/Importance of Adequate Fresh Air.....	4
Safety Steps.....	5
Burning Solid Fuels.....	6, 7
Unpacking Your MagnumM Appliance .....	7, 8
Clearances.....	9
Guidelines for Exhaust Venting Systems Design.....	10, 11
Design Guidelines for Outside Combustion Air Connection.....	12
Installation Precautions.....	13
Installation Configurations.....	14
Vent Termination General Instructions.....	15
Horizontal Installation.....	16
Vertical Installation.....	17, 18
AC Control Panel/Thermostat Hook-up.....	19, 20
MagnumM WIN Insert Installation .....	21, 22, 23
Installation Instructions.....	24, 25, 26
Control Panel/Thermostat Hook-up.....	27
Optional 12 Volt Battery Back-up.....	28
Operating Instructions All Models.....	29, 30, 31
Cleaning Instructions.....	32, 33
Cleaning Instructions for the Winchester Insert.....	34, 35
Automatic Features.....	36
Glass Maintenance, Adjustment, Removal and Replacement.....	37
Circuit Board Functions.....	38, 39
Setting the Draft.....	39
Wiring Diagram AC.....	40
Igniter Replacement.....	41
Trouble Shoot Guide.....	42, 43, 44, 45
MagnumM Winchester Replacement Parts List.....	46, 47
Warranty.....	48
Service Record.....	49

**TESTING/CERTIFICATION INFORMATION**

The MagnumM WIN stove (report # 150-S-01b-4) independently tested in accordance with ASTM E1509

The MagnumM WIN Insert (report # 097-S-04-2) independently tested in accordance with ASTM E1509

Tested with OMNI-Test Laboratories, Inc, BEAVERTON, OREGON 97005

per EPA Method 28A, ULC C1482-M1990, CAN/ULC-S627-00, ULC-S628, APFI req.

The pellet fired appliance has been tested and listed for use in manufactured homes in accordance with

Oregon

Administrative Rules 814-23-900 through 814-23-909 (UM) 84-HUD

SERIAL # \_\_\_\_\_ DATE PURCHASED \_\_\_\_\_

**READ THIS MANUAL THOROUGHLY BEFORE INSTALLING THIS UNIT AND KEEP THIS  
MANUAL IN A HANDY PLACE FOR FUTURE REFERENCE.**

## DEAR VALUED MAGNUM PRODUCT OWNER,

We appreciate your decision to help preserve our precious environment by purchasing your **MagnuM Corn/Biomass Appliance**. With everyone working together, we can have clean air and renewable heat for our homes.

Please read this Owners Manual carefully before using this appliance and if you have any questions contact your local **MagnuM** dealer. We appreciate your business and wish you many warm days and nights with your new **MagnuM Corn/Biomass Appliance**.

Sincerely,  
Mike Haefner, President  
American Energy Systems, Inc.

**P.S.** You are very important to the success of our business and your referral of our products is very much appreciated. We invite you to go to [www.magnumheat.com](http://www.magnumheat.com) to fill out the online product referral card to win extra dollars for YOU. Join our Facebook and Twitter family while you are there. GOOD LUCK!

## SPECIFICATIONS

American Energy Systems, Inc., manufacturer of the **MagnuM Winchester Appliances**, reserves the right to alter its products, their specifications and/or price without notice.

Safety tested and EPA exemption tested by Omni to UL 1482, CAN/ULC-S627, ULC-S628, APFI requirements, Oregon administrative rules 814-23-900 to 814-23-909 and E.P.A. Method 28A.

	Winchester	Insert
Heating range	9,000- 45,000 BTU	
Fuel Storage Capacity	Up to 68 Lbs.	Up to 60 Lbs.
Width	24"	23 1/2"
Height	33"ped, 40"leg,	21 1/2"Insert
Depth	22"	21 1/2"

	<b>CLEARANCE TO COMBUSTIBLES, Stoves Insert clearance to combustibles are on pages 21-24</b>
	Vertical Termination w/3" Pellet Vent
<b>Back Wall</b>	3" (75mm)
Side	3" (75mm)
Corner	3" (75mm)
Flue to Wall	3" (75mm)
Floor Protection	6" (150mm) out in front of unit 6" to sides

BTU input will vary, depending on the brand of fuel, size of fuel, quality of fuel and moisture content. Consult your authorized MagnuM reseller for information on the best fuel to use to get the best results. Fuel feed rates can vary as much as 50 percent depending on fuel quality, size, brand and moisture content.

# Technical Bulletin

## Importance of Adequate Fresh Air

Every home is a slightly different situation and depending on the design of the air movement within the home, might be easy to distribute heat or very difficult. If you have boiler heat or other non-ducted central heating this becomes even more of a challenge as adequate circulation within the home and proper make up air for combustion is lacking because of the design of your central heating system.

When a forced-air system is put into a home that is not designed with proper circulatory patterns, it might be necessary to add return air ducts or at least vents to get the air moving around the home. Fresh air for the home and fresh air for combustion will have to be added or the stove or furnace will burn dirty and efficiency will suffer.

Your dealer needs to assess the fresh air requirements for the home. At a minimum, there should be a 6" or larger (this should be determined by figuring what the home requires) fresh air vent coming in to a neutral part of the home to make sure that there is adequate fresh air to the home. Then the 3" make up air to the unit is required to be provided.

If the Biomass Fuels are not burning correctly you need to address a few things. Are the Biomass Fuels wet or dirty? If they are, make sure that your Biomass Fuels are cleaned (we have an excellent "E-SIFTER" product that will do a great job) and below 15 percent moisture. 3-4 percent moisture is ideal.

The most common cause of Biomass Fuels not burning properly is contaminated air or negative pressure in the home. It can be as simple as the air adjustment not set properly on the side of the stove or it could be that there is a serious lacking of good quality air in the home caused by negative pressure. If you have done any remodeling or if this is a newer home, it is a very real possibility that this is happening. Most basements have negative pressure even if you feel that your home is drafty. This is called the stack or chimney effect.

If there is a black coating of soot coming into the home it is caused by the reversal of the exhaust that would normally exit the stove outside being drawn into the home by negative pressure or improperly installed venting. Depending on your venting configuration this could be aggravated by back drafts, high wind and cold chimneys.

Sometimes this also occurs if there is an intake for fresh air too close to the exhaust on the outside of the home or other conditions causing the exhaust to be pulled back into the home.

The first indications of negative pressure affecting the stove occurs app. 3 days after the stove is lit. The glass gets dirty very easy, the firepot might keep filling up even though you pull the air adjustment out, and you notice that the venting fills up with soot rapidly. After a few days, the exhaust can no longer adequately pull out all of the fly ash so it reverses and is pulled into the home. This might happen through the venting if it is not sealed properly or it might come out when you open the door for maintenance and also backwards through the air wash system.

This can be easily corrected by adding the fresh air for the home and also for the appliance. It is imperative that you would have your dealer or installer check the unit out for proper operation to make sure that there is nothing mechanical wrong with the appliance and then determine your need for proper fresh air. Your dealer can contact the factory with any questions that he might have.

## SAFETY STEPS

**IMPORTANT:** Proper installation of this stove is crucial for proper and safe operation. Installing this product improperly may result in a house fire and/or personal injury. All applicable building codes for your location must be followed. In areas where building codes require additional steps to the installation of this product not included in this manual, the building codes will take precedent and must be followed. Contact your local building inspector to obtain any necessary permits or inspection guidelines before installing the product. **(This appliance must be installed by a trained professional installer to assure proper installation and warranty of this product) Warranty labor, parts failing due to improper installation and shipping will not be covered if the unit is not installed by a trained installer.**

- ✓ **DISCONNECT THE POWER CORD BEFORE SERVICING THIS STOVE!** A power surge protector is required. The unit must be plugged in to a **grounded** 120 volt 60 Hz.
- ✓ Always route the power cord away from the unit. Do not route cord in foot traffic areas. Do not pinch cord under furniture. Do not add any additional length to the power cord.
- ✓ This product requires simple periodic maintenance for proper operation and long life of the stove. Read and follow the maintenance schedule closely. **Do not operate with the doors or hopper open.**
- ✓ **The Magnum Winchester stove models are designed, approved and tested to burn corn and other Biomass fuels.** The burning of other solid fuels such as cord wood in this stove is not permitted. If you are burning fuels not approved for this appliance it will void the warranty and no service/warranty will be allowed.
- ✓ The Magnum models will burn high ash content fuels but will require additional maintenance/cleaning.
- ✓ A working smoke detector must be installed in the same room as this product.
- ✓ It is recommended that a fire extinguisher “class a-b-c” be installed close to the appliance.
- ✓ Flammable or explosive liquids such as gasoline, naphtha or engine oil must NEVER be used in or around this stove. These liquids must be stored well away from this stove as the open flame in the burn chamber could ignite the fumes of such liquids. **Do not burn garbage in this unit.**
- ✓ According to HUD requirements, when installed in a mobile home, this stove must be grounded directly to the steel chassis of the mobile home and bolted to the floor.
- ✓ This stove is not intended for use in commercial installations but can be used.
- ✓ The moving parts of this stove are propelled by high torque electric motors. The auger can cause severe injury to body parts that may get near them. Keep all body parts away from the auger while the stove is plugged into an electrical outlet. These moving parts may begin moving at any time while the stove is plugged in.
- ✓ This unit must be installed on a non-combustible surface. Make sure that the unit is level.
- ✓ Do not attempt internal service to the unit when it is burning and or plugged into power.
- ✓ It is a good idea to burn the unit outside for a couple hours before installation to burn off any paint or oil fumes. (Most resellers pre-burn the unit before you receive them, do not worry if your unit looks like it has been burnt.)

**IMPORTANT:** It is the customer’s responsibility to make sure the Magnum appliance is installed with the proper make up air system and the home is checked for adequate fresh air so that the appliance does not become the fresh air source for the home. It has been determined that without fresh air directly connected to the appliance you will have a high possibility of product failure, safety systems shutting down and incomplete burn causing excessive ash, soot buildup and plugging.

## **BURNING SOLID FUELS (shelled corn and Biomass Fuel)**

Unlike petroleum and natural gas products, solid fuels create ash as the fuel is burned. Even with the highly efficient flame your **MagnuM** stove will produce, the solid fuels used will produce ash. This ash will have to be cleaned out of the stove from time to time. The cleaning procedure will be discussed later in this manual. You can minimize the amount of cleaning required and maximize the efficiency of your stove by maintaining the correct draft settings.

The draft setting on your stove may have to be changed from time to time to accommodate your specific burning conditions. Proper draft setting will be discussed later in this manual. The point we wish to make here is that your **MagnuM** stove, due to the nature of solid fuels, will require brief periodic attention. Please do not expect to light your stove and walk away from it until you want to shut it off in the spring. A few moments of adjustment and cleaning from time to time is an important part of burning solid fuels.

The **MagnuM** stove has been designed to burn shelled corn and other grains and biomass fuel. Since these fuels vary greatly in quality and consistency, AES cannot be responsible for damage done to your stove due to fuel problems. The following are guidelines to using and selecting proper fuels for your stove.

### **SHELLED CORN (11-12 percent moisture recommended)**

- ✓ Store your corn supply in a dry place and keep the bags or containers sealed to prevent your corn from absorbing excess moisture. Test the moisture content periodically to maintain the proper dryness.
- ✓ **Check your corn for foreign objects. Your stove warranty will not cover damage done to your stove due to foreign objects in the fuel supply.**
- ✓ **Do not carry your corn supply over into the next heating season if possible unless properly stored.** If you carry over your corn supply make sure to check the corn for proper moisture content.
- ✓ **DO NOT BURN “TREATED” SEED CORN IN YOUR STOVE.** Seed corn is treated with chemical pesticides that are harmful or fatal if swallowed; therefore, seed corn is dangerous to have in the house, especially where children can reach it. **Burning treated seed corn in your stove will void the warranty and will destroy the exhaust system on the unit.**
- ✓ **Corn must be 14% or less moisture content.** Wet corn will cause rapid plugging and deterioration of the stove and exhaust system, lower the heat output and will void the product warranty.
- ✓ Corn must be cleaned and free from debris. Corn right from the field will often have stalks, sticks, bolts and cob debris, which can plug the auger and/or cause damage to the auger and motor. Damage caused by dirty corn and other foreign objects are not covered by the product warranty. Ask for clean corn when you purchase it from your local corn supplier. Clean corn can be purchased in bulk or bagged from most elevators, feed stores or even your local farmer.

**ALWAYS ASK FOR CORN WITH 11-12% MOISTURE CONTENT.**

- ✓ **If you are having trouble finding clean Corn, contact your local MagnuM Dealer and ask them to get you an “Energy Sifter” corn cleaning system.** Cleaning your corn with the Energy Sifter from American Energy Systems will assure clean corn and a more consistent burn rate. It is also important to vacuum out your hopper once a month to assure trouble free auguring of the corn.

- ✓ There are many varieties of corn grown around the world. Each variety has unique characteristics including the shape and size of the kernel. Your stove will burn more consistently with a small to mid-size kernel corn. If the kernel size of the corn varies greatly or if you switch sources frequently, you will get a less consistent burn, which will require more attention to the draft setting on your stove. Therefore, purchasing corn from the same source will help achieve a more consistent burn. **DO NOT USE CORN WITH A HIGH WAX CONTENT!**

### **Biomass Fuel**

- ✓ Be consistent in your Biomass Fuel Fuel supplier. Biomass Fuels will vary in content and burn characteristics from supplier to supplier. A consistent supply of Biomass Fuels will require fewer adjustments to the draft of the stove.
- ✓ Check your Biomass Fuels for foreign objects. Your stove warranty will not cover damage done to your stove due to foreign objects in the fuel supply.
- ✓ Store your Biomass Fuels in a dry place to prevent them from absorbing excess moisture.
- ✓ Vacuum the hopper out after every 6-7 bags to eliminate buildup of sawdust. More often if the Biomass Fuels are poor quality. If sawdust is a problem you will have to screen each bag of fuel for a consistent feed.
- ✓ Biomass Fuels vary from supplier to supplier in ash content from less than 1% to 3% or more. Low ash content pellets will allow you to burn the stove longer between cleanings. Only Biomass Fuels manufactured to the Association of Pellet Fuel Industries (A.P.F.I.) standard for Super & Premium residential pellet fuels are recommended. Look for A.P.F.I. registration number on the back of pellets. Consult your local **Magnum** reseller for more information on approved Biomass Fuel fuel.
- ✓ It is strongly recommended not to keep a supply of Biomass Fuels over the summer months. Moisture will build up and cause problems in the fall with your appliance operation. Make sure that your supplier is not selling you left over fuel or fuel that has been out in the rain.

## UNPACKING YOUR MAGNUM CORN/BIOMASS FUEL UNIT

**When you receive your Magnum Corn/Biomass Fuel Stove, Pedestal unit, Leg unit or Fireplace Insert, be careful to inspect all parts and components to make sure that nothing was damaged or lost in shipment. If there was shipping damage, be sure to report it to your Magnum reseller, or the shipping company that delivered your unit. Freight damage claims must be made to the Freight Company immediately. If parts are missing contact your local Magnum reseller or contact the factory right away. Your satisfaction is our top priority.**

To uncrate your **Magnum appliance**:

- 1) Cut the banding straps and open the carton lid. The carton is stapled to the wood pallet so it will be necessary to pull the cardboard loose from the pallet. Remove the crating box carefully lifting up over the top of the unit. Be careful not to scratch the unit with the staples. Remove the wood blocks and plastic. We strongly urge you to recycle the packaging materials to help protect the environment.

The Pedestal unit comes completely assembled, the Insert comes with the shroud packaged separately and the Leg unit comes with the legs packaged in the hopper.

The installation of the Insert shroud is shown later in the installation manual. Make sure that the shroud is with the unit when you get it.

The following diagram will show how to install the legs on the Leg Unit. The legs are wrapped up and packaged in the hopper. Unpack the legs and get the four (4) nuts out of the hardware bag.

Tip the unit back so that you can get the leg onto the bolt that is sticking down in each corner of the bottom of the base. Be sure to have someone helping hold the unit while you are attaching the leg. The casting could break if bound or dropped.

**NOTE: It is best to attach the legs on one side first and then lift the unit up level to attach the other side. You can also attach the legs on the back two corners first and then the front.**

Place the ¼" nut on the bolt that is located on the base of the unit and attach the leg to the bolt. Swing the leg so that the foot of the leg is parallel with the 45-deg. angle of the front of the unit. Align the back leg to match the front leg.

Be careful not to bind the leg when bolting onto the unit so that it does not break. The legs are designed to face at a 45 degree angle so that they will face in the same direction as the slanted side of the face.

When the legs are bolted on and positioned where you like them, tighten the four (4) nuts. Make sure not to over tighten the nuts and twist them off.

# CLEARANCES

**NOTE: Clearances for the Insert models are shown on pages 21-24**

## CONVENTIONAL CLEARANCES

A...SIDEWALL	3 In. (75 mm)
B...BACK WALL	3 In. (75 mm)..... (VERTICAL VENTING INSTALLATION REQUIRES A MIN. 3" CLEARANCE FROM COMBUSTIBLES TO VENT PIPE).
C...CORNER WALL	3 In (75 mm)..... (VERTICAL VENTING INSTALLATION REQUIRES A MIN. 3" CLEARANCE FROM COMBUSTIBLES TO VENT PIPE).
D...VENT PIPE TO WALL	3 In (75 mm)..... (MAINTAIN 3" CLEARANCE FOR ALL INSTALLATIONS)
E...FLOOR PROTECTION FRONT	6 In (150 mm)
F...FLOOR PROTECTION SIDES	6 In (150 mm)

Floor protection must be 3/8" minimum thickness non-combustible material or equivalent extending beneath heater and to the front/side/rear as indicated.

### HORIZONTAL INSTALLATION

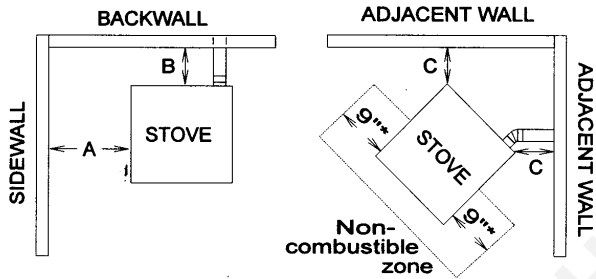

### FLOOR PROTECTION

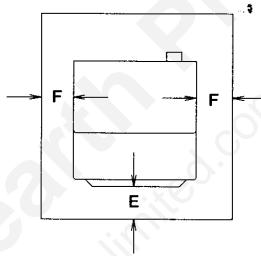

\* Sides of the stove to the front of the grill openings must have a 9"inch clearance.

### VERTICAL INSTALLATION

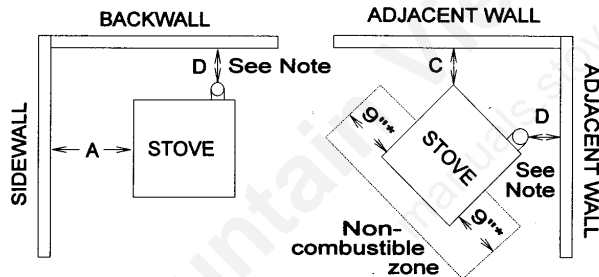

CHIMNEY AND CONNECTOR: 3" LISTED PELLET VENT ONLY

NOTE: REGARDLESS OF STOVE CLEARANCE, VENT PIPE MUST ALWAYS HAVE A 3" INCH CLEARANCE.

### ALCOVE CLEARANCES

MIN. ALCOVE WIDTH	27 In. (694 mm)
MIN. ALCOVE HEIGHT	47 In. (1194 mm)
MAX. ALCOVE DEPTH	36 In. (914 mm)

**WARNING: THE MINIMUM CLEARANCES LISTED ABOVE ARE BASED ON 3" PL LISTED PELLET VENT PIPE. IF YOUR APPIANCE IS NOT PROPERLY INSTALLED A HOUSE FIRE MAY RESULT. PLEASE FOLLOW THE PIPE MANUFACTURERS INSTRUCTIONS AND LOCAL BUILDING CODES FOR THE CLEARANCE TO COMBUSTIBLES REQUIRED FOR THE INSTALLATION OF THE VENT PIPE BEING USED.**

## GUIDELINES FOR EXHAUST VENTING SYSTEMS DESIGN

**It is recommended that only an authorized Magnum installer install your stove.** The following installation guidelines must be followed to ensure conformity with both the safety listing of this stove and to local building codes.

- ✓ A listed 3” or 4” type “PL” corn/pellet vent exhaust system must be used for FREESTANDING installation and attached to the pipe connector provided on the back of the stove. Use a 3” to 4” adapter for 4” pipe. A cap must be used at the termination of type “L” vent chimneys.
- ✓ Do not terminate vent in any **enclosed or semi-enclosed** area, such as; carports, garage, attic, crawl space, under a sundeck or porch, narrow walkway or closed area, or any location that can build up a concentration of fumes such as a stairwell, covered breezeway, etc.
- ✓ Vent surfaces can get hot enough to cause burns if touched by children. Non-combustible shielding or guards may be required. **Do not install a flue damper in the exhaust vent of this unit.**
- ✓ Termination must exhaust above air inlet elevation. **It is recommended that at least 3 ft. of vertical pipe be installed when the appliance is vented directly through a wall or in a basement.** This will create some natural draft to prevent the possibility of smoke or odor during appliance shutdown and to keep exhaust from causing a nuisance or hazard from exposing people or shrubs to high temperatures. In any case, the safest and preferred venting method is to extend the vent through the roof. **Do not connect this unit to a chimney flue serving another appliance.**
- ✓ Distance from doors and windows, gravity or ventilation air inlet into building:  
Not less than 4 ft. / 1.2 m below, 4 ft. / 1.2 m horizontally from, 1 ft. / 305 mm above (This does not apply if the windows are non-opening or have been fixed so they cannot open.)
- ✓ Distance from bottom of termination and grade – 1 ft. / 305 mm minimum. This is conditional upon the plants and nature of grade surface. The exhaust gases are not hot enough to ignite grass, plants or shrubs located in the vicinity of the termination. The grade surface must not be a lawn. Distance from bottom of termination and public walkway is 7ft. / 2.1m minimum.
- ✓ Distance to combustible materials – 2 ft. / 610 mm. This includes adjacent building, fences, protruding parts of the structure, roof overhang, plants and shrubs, etc.
- ✓ It is recommended that a single or double clean-out “tee”, for cleaning the vent in both directions, be installed at every 90-degree junction to enable collection of fly ash and to permit periodic cleaning of the exhaust system. 90-degree elbows accumulate fly ash and soot, thereby reducing exhaust flow and performance of the stove.
- ✓ Total length of horizontal vent must not exceed 10 feet / 3,000 mm. All joints in the vent system must be fastened by at least three (3) screws, and all joints must be sealed with *high temp* RTV silicone sealer to be airtight.
- ✓ A 3” single-wall, stainless steel flexible or rigid exhaust pipe should be used for INSERT installations and must be attached to the stove with a single-wall, stainless steel “tee” with a clean-out cap. The stainless steel “tee” should be inclined at 45-degrees to enable the vent to be centered on the stove and allow the “tee” to be cleaned without removing the stove (see diagram 11.1).
- ✓ When venting into an existing masonry or factory built chimney, the chimney must be cleaned, with all creosote removed. The chimney must be a type suited for solid fuel. **WARNING:** The chimney and the chimney connections must be kept clean and in good condition.
- ✓ The “PL” venting or single wall stainless exhaust system must be installed so as to be GAS TIGHT! The vent manufacturer’s installation procedures must be followed. In addition, pipe connections, joints and all pipe seams within the home should be sealed with high temperature RTV silicone sealer.
- ✓ If an insert is to be installed into an unlined masonry chimney, it is recommended that a 3” or 4” stainless steel pipe be extended to the top of the existing chimney. The top of the existing chimney should be sealed with a steel plate (see diagram 11.2).

**GUIDELINES FOR EXHAUST VENTING SYSTEMS DESIGN, CONT.....**

To determine whether a 3” or 4” exhaust system should be used, follow the guidelines below:

- 1) Determine the “equivalent pipe length” for each component used according to the comparison chart below. Add the “equivalent pipe length” of all components to get the “total equivalent pipe length”.
- 2) Determine the altitude at which you are installing the stove.
- 3) Cross-reference the “total equivalent pipe length” and the altitude using the graph below.

**NOTE:** The “total equivalent pipe length” should not exceed 30’ feet.

**Diagram 11.1**

Component	Equivalent Length	Equivalent Pipe Length			
Horizontal Straight Pipe	Actual Length in ft. x 1.0	Horizontal Pipe	=	1 x (2+1) =	3 ft.
Vertical Straight Pipe	Actual Length in ft. x 0.5	Vertical Pipe	=	0.5 x 8 =	4 ft.
90° Elbow or Tee	5.0 feet	90 Degree Tee	=	2 x 5 =	10 ft.
45° Elbow	3.0 feet	45 Degree Tee	=	1 x 3 =	3 ft.
		<b>TOTAL</b>	=		<b>20 ft.</b>

**NOTE:** These are guidelines only. Proper venting is accomplished by design and common sense. In most installations 3” diameter venting is adequate. If it does not vent properly you will have to change it to 4”.

**Diagram 11.2**

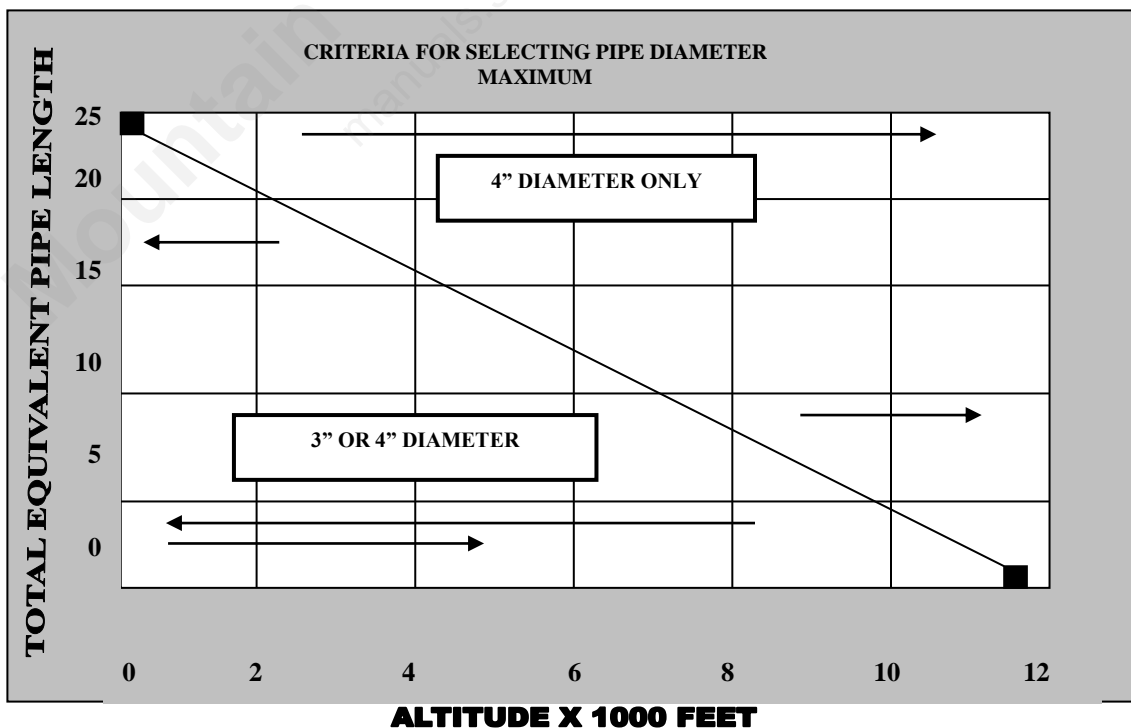

## DESIGN GUIDELINES FOR OUTSIDE COMBUSTION AIR CONNECTION

### OUTSIDE MAKE-UP AIR FOR COMBUSTION IS REQUIRED ON ALL INSTALLATIONS

- 1) For FREESTANDING installations with horizontal through-the-wall exhaust, it is REQUIRED that the stove combustion air intake be connected to a fresh air intake outside. If the home is newer or has been tightly insulated it is imperative to the operation of the unit to install outside combustion air. If you do not, then an additional 6" intake into the furnace room in the basement is required.
- 2) For INSERT installations into an existing fireplace, or FREESTANDING installations with a vertical exhaust, outside air connection is required. It is not recommended to exit the fresh air intake out the top of the chimney.
- 3) Connection to outside the house is REQUIRED for all installations.

**IMPORTANT:** It is the customer's responsibility to make sure that there is adequate fresh air to the home so that the MagnuM appliance does not become the fresh air source. Depending on length of run, elbows and configuration you will have to increase the size of the fresh air intake. Typically you would increase from 3" to 4" over 10' of run or more than 2 elbows.

#### 90 DEGREE BEND TERMINATION

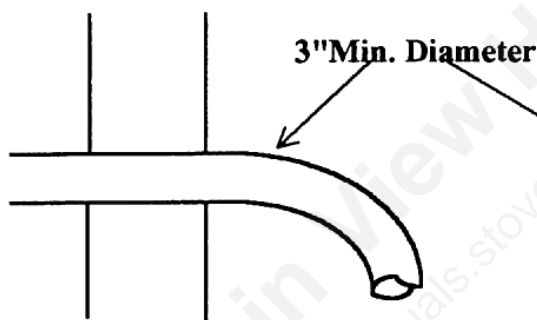

#### WIND HOOD TERMINATION

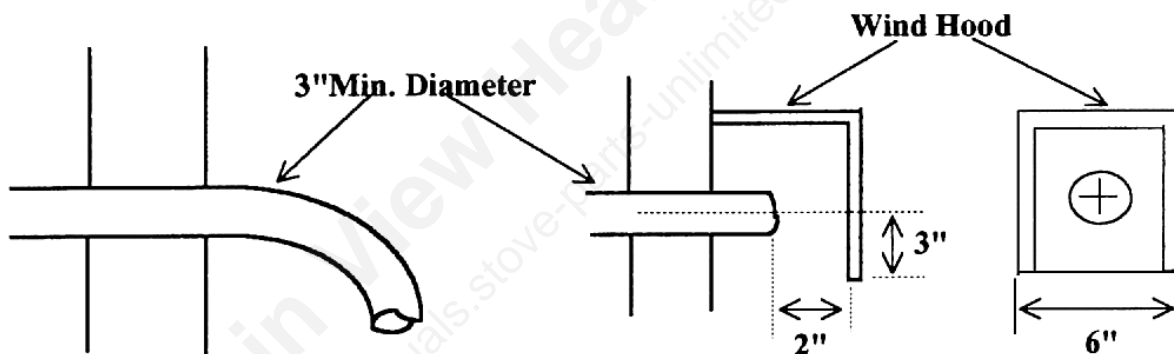

- 4) Only non-combustible piping 3" in diameter is approved to use for outside air connections (straight or flexible). PVC pipe is NOT approved and should NEVER be used.
- 5) If the air inlet is connected to the outside, it MUST be terminated with a vertical 90-degree bend (down) or with a wind hood. Failure to do so could result in a burn back during high winds blowing directly up the air inlet during a simultaneous power failure (see diagram above).
- 6) It is important not to terminate the inlet of the fresh air intake too close to the venting outlet for the exhaust. It is recommended that the inlet for the fresh air is a minimum of 3' to 5' feet away from the venting outlet and at least 1'-2' feet below.
- 7) Blockage, excessive length, or bends in the air intake pipe will starve the stove of combustion air. A 90-degree bend is equivalent in restriction to approximately 30" of straight inlet pipe.

## INSTALLATION PRECAUTIONS

**CAUTION:** Do not install this appliance in any manner other than as described in this manual. If you have any questions about properly venting or installing your **MagnuM** corn/Biomass Fuel stove, please contact your dealer or American Energy Systems, Inc. for information.

**NOTE: THIS STOVE MUST BE BURN TESTED OUTSIDE IN A WELL VENTILATED AREA FOR AT LEAST FOUR (4) HOURS. THIS WILL CURE THE PAINT AND SEASON THE STOVE METAL. SMOKING AND STEAMING IS NORMAL DURING THE CURING PROCESS, AND MAY CONTINUE DURING THE FIRST FEW TIMES THE STOVE IS USED.**

The **ONLY** authorized exhaust vent pipe for this appliance is **3” or 4” listed Type PL corn/pellet vent pipe**, designed for use with pellet stoves. This stove may be connected to an existing factory-built chimney using pellet vent pipe as a connector, and a 3”-4”, 3”-6”, or 3”-8” **CORN/PELLET VENT to CHIMNEY ADAPTER**. Follow the pellet vent pipe manufacturer’s instructions for the installation of the vent pipe being used. (See “Existing Vertical Installation”).

**As you plan your installation, consider the following:**

- The stove should be placed as central in the home as possible. Consider safety, convenience, traffic flow and the fact that the stove will need a venting system and fresh air to the outside of the home.
- Before drilling or cutting holes, select the location of the appliance. Determine where the ceiling rafters, wall studs or floor joists are located before making any large holes as the appliance may have to be moved.
- Care must be taken to maintain minimum clearances to combustibles as per local building codes, fire codes, and the safety listing tag on the inside hopper lid.
- An outside air source **must be** connected to the stove and can be brought in through the sidewall or vented crawl space. Flexible or rigid pipe should be used and will connect to the adaptor on the back of the stove. (See air inlet location under the **CLEARANCE** section of this manual)
- Place the stove where you will enjoy watching the fire along with getting the best heat distribution possible. Locating the stove in a closed room will not allow the unit to perform properly. Installing the stove in an un-insulated area will also not allow the stove to heat the home properly.
- If the home was not designed with proper heat circulation, the stove will not perform properly. Make sure that the installer looks at the entire home as a unit when installing your **MagnuM** appliance. Make sure that there is adequate cold air returns to pull the heat to adjoining rooms.

**DO NOT CONNECT THIS STOVE TO A CHIMNEY FLUE SERVING ANOTHER APPLIANCE.**

**DO NOT USE SINGLE WALL PIPE FOR ANY INSTALLATION.**

**DO NOT INSTALL A FLUE DAMPER IN THE EXHAUST VENTING SYSTEM OF THIS UNIT. THIS EXHAUST SYSTEM IS PRESSURIZED.**

Electrical power is 120 volt-60 Hz. The stove is provided with a six foot grounded electrical cord, and should be connected to a standard 3 prong 120 volt, 60 Hz electrical outlet. (Make sure you have a surge protector installed.) Do not route the cord in front of, or under the stove.

**NOTE: A MAJOR CAUSE OF VENT RELATED FIRES IS FAILURE TO MAINTAIN REQUIRED CLEARANCES (AIR SPACES) TO COMBUSTIBLE MATERIAL. PLEASE FOLLOW THE VENT PIPE MANUFACTURERS INSTRUCTIONS AND LOCAL BUILDING CODES FOR THE PROPER CLEARANCES TO COMBUSTIBLES REQUIRED FOR THE INSTALLATION OF THE VENT PIPE BEING USED.**

## INSTALLATION CONFIGURATIONS

The Magnum Corn/Biomass Fuel Appliances may be installed as follows:

- 1) A freestanding unit (with a pedestal only).
- 2) A hearth mounted fireplace insert into a masonry or factory built fireplace.
- 3) A built-in heater mounted in an alcove with a pedestal.
- 4) A built-in heater mounted on a non-combustible floor without a pedestal.

### MOBILE HOME INSTALLATION REQUIREMENTS

**IN ADDITION TO THE STANDARD INSTALLATION INSTRUCTION, THE FOLLOWING REQUIREMENTS ARE MANDATORY FOR INSTALLATION IN A MOBILE HOME:**

**WARNING**  
**DO NOT INSTALL IN SLEEPING ROOM**

- 1) Stove must be permanently bolted to the floor.
- 2) Stove must have permanent outside air source.
- 3) Stove must be permanently, electrically ground to the steel chassis of the mobile home. (12 ga. or larger wire)
- 4) All vertical chimney vent must have wall supports every five (5') feet.
- 5) All exhaust systems must have a spark arrestor.

### **CAUTION**

**The structural integrity of the mobile home floor, wall and ceiling must be maintained.  
Check with your local building official as other codes may apply.**

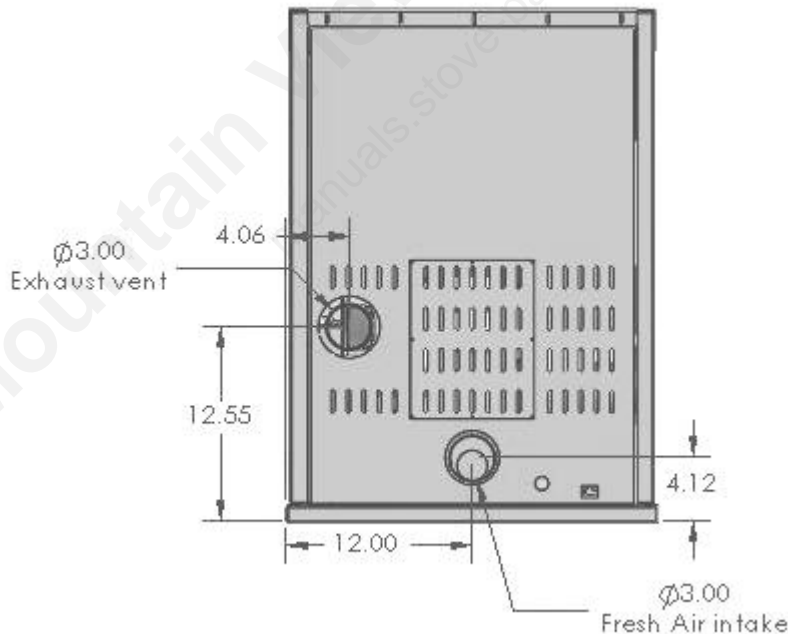

# VENT TERMINATION GENERAL INSTRUCTIONS

**NOTE:** The following are general instructions for installing this appliance.

**THE CORN/PELLET VENT MANUFACTURER'S INSTRUCTIONS SHOULD BE FOLLOWED FOR THE VENT PIPE BEING USED. USE ONLY 3" or 4" LISTED TYPE PL CORN/PELLET VENT PIPE.**

**WARNING: Shut off all electrical power to the wall or room where the appliance is going to be installed before cutting any holes. Be careful not to drill or cut into any water lines or electrical wiring as water damage or electrical fire may result.**

Upon determining the best location for your new appliance, maintain at least the minimum allowable clearances. Line up a plumb bob to the flue collar on the stove with the location for the hole in the wall or ceiling before drilling or cutting any holes. (See rear exhaust and air inlet locations under the **CLEARANCE** section of this manual.) **Be sure to allow for any stove pad that you will be placing underneath the unit.**

Prepare the vent pipe for painting (if you are painting the venting) by wiping down with straight vinegar. Rinse vinegar off with clean water and allow the pipe to dry. Use high temperature paint as directed by the manufacturer (the standard paint is Stove Bright Metallic Black). Let the paint dry for a couple hours before assembling.

Drill and enlarge the hole as required for installation of the wall thimble, vent pipe and components **per the pellet vent manufacturer's instructions.**

Connect the pipe and lock the joints as directed by the pellet vent manufacturer, and secure the vent pipe to the flue collar on the back of the stove. Add a small bead of RTV high temperature silicone around the outside edge of the flue collar prior to securing the vent pipe. Drill and attach the vent pipe to the flue collar with sheet metal screws. **Alternate (preferred) method:** Attach the approved PL pipe adaptor on the back of the exhaust pipe located on the rear of the appliance, secure with a 3" hose clamp and then attach all venting to the pipe adaptor.

Do not terminate the vent in any enclosed or semi-enclosed area, such as a carport, garage, attic, crawl space, under a sun deck or porch, in a narrow walkway or closely fenced area, stairway, covered breezeway, or any other location which can build up a concentration of flue gases.

Vent surfaces can become hot enough to cause burns if touched. Non-combustible shielding or guards may be required.

**Note:** Make sure that you leave adequate clearance between the back of the unit and the wall to allow for proper cleaning, servicing, and for when you open the hopper lid, that it does not hit the wall. It is recommended that you leave 4"-6" of clearance between the appliance and the back wall of the home.

**NOTE: THE VENT PIPE SHOULD BE INSPECTED FREQUENTLY TO VERIFY THE INTEGRITY OF THE VENTING SYSTEM AND TO INSURE THAT NO OBSTRUCTIONS OR BUILD-UP EXIST WITHIN THE VENT PIPE. FAILURE TO INSPECT THE VENT PIPE CAN CAUSE A MALFUNCTION OR HAZARDOUS OPERATION OF THE STOVE.**

# HORIZONTAL INSTALLATION

EXHAUST VENT TERMINATION SHALL BE AS FOLLOWS:

A MINIMUM OF 4' FEET/1220mm BELOW, BESIDE AND 1' FOOT ABOVE ANY DOOR OR WINDOW THAT OPENS, OR ANY OPENING INTO A BUILDING.

A MINIMUM OF 2' FEET/610mm FROM ANY ADJACENT BUILDING OR OVERHANG.

A MINIMUM OF 7' FEET/2130mm ABOVE GRADE, WHEN LOCATED ADJACENT TO PUBLIC WALKWAYS.

A MINIMUM OF 2' FEET/610mm ABOVE GRASS, PLANTS OR OTHER COMBUSTIBLES.

Note: The pipe lengths shown are for reference only.  
Your actual pipe length requirements may differ.

SINGLE WALL PIPE SHALL NOT BE  
USED FOR ANY INSTALLATION.

HORIZONTAL INSTALLATION SHALL  
BE A MAXIMUM OF 5' FEET.

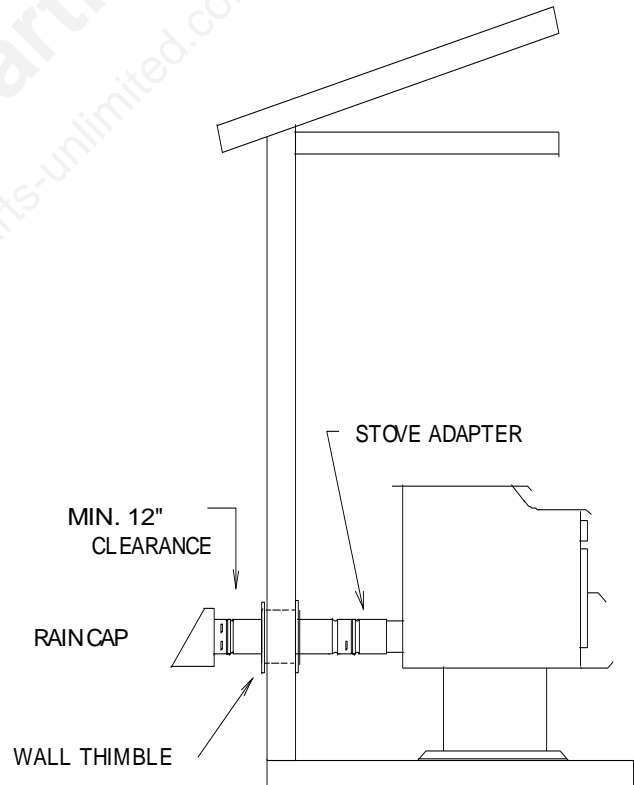
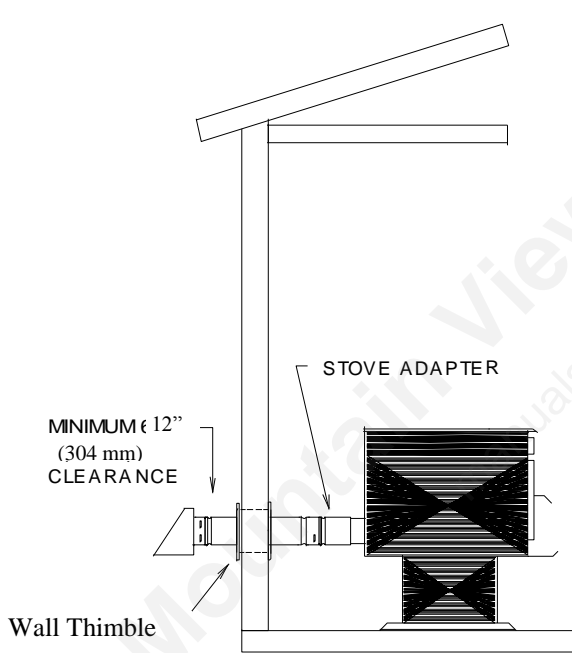

**WARNING:**  
Vent surfaces can become hot enough to cause burns  
if touched. Non-combustible shielding may be required.

**PLEASE FOLLOW THE PELLET VENT MANUFACTURER'S INSTRUCTIONS AND LOCAL BUILDING CODES  
FOR THE CLEARANCES TO COMBUSIBLES REQUIRED FOR INSTALLATION OF THE VENT PIPE BEING  
USED.**

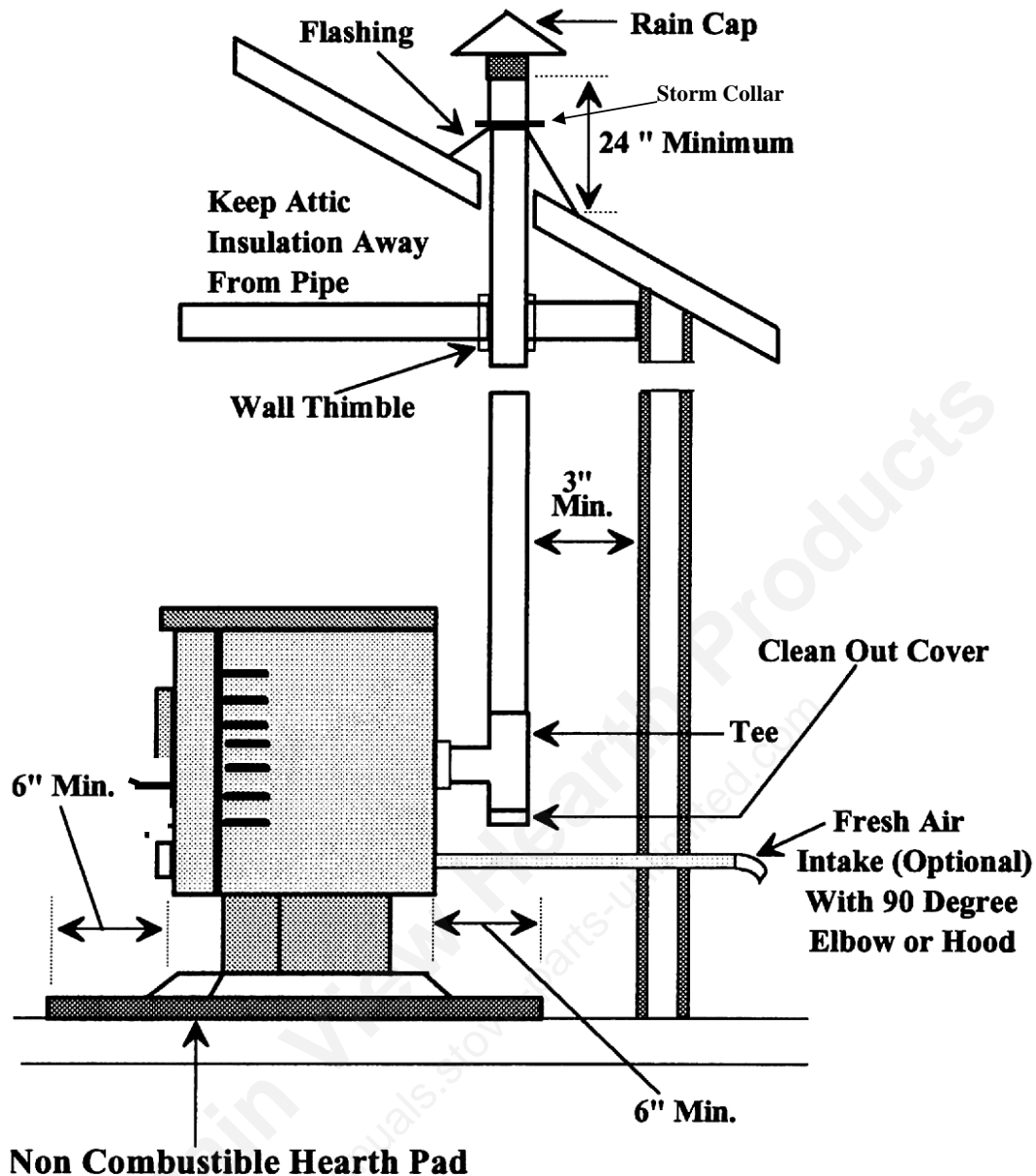

### INSIDE VERTICAL PIPE WITH ROOF TERMINATION

## VERTICAL INSTALLATION

#### GUIDELINES FOR CONNECTING TO AN EXISTING FACTORY-BUILT CHIMNEY:

1. Inspect the chimney for the presence of creosote, soot or other combustible deposits, and blockage or obstructions. Thoroughly clean the chimney and remove any obstructions.
2. Thoroughly inspect the chimney for soundness, proper clearances and presence of all necessary parts, including a chimney cap, prior to making the connection.
3. This stove may be connected to an existing ceiling-mounted factory-built chimney with a diameter of 4", 6", or 8".
4. Use a 3"-4", 3"-6" or 3"-8" corn/pellet vent to chimney adapter provided by the pellet vent manufacturer.
5. Use only listed 3" Type PL corn/pellet vent pipe between the stove and the chimney.
6. Follow the corn/pellet vent manufacturer's instructions to assemble the vent pipe and make the connection to the chimney.

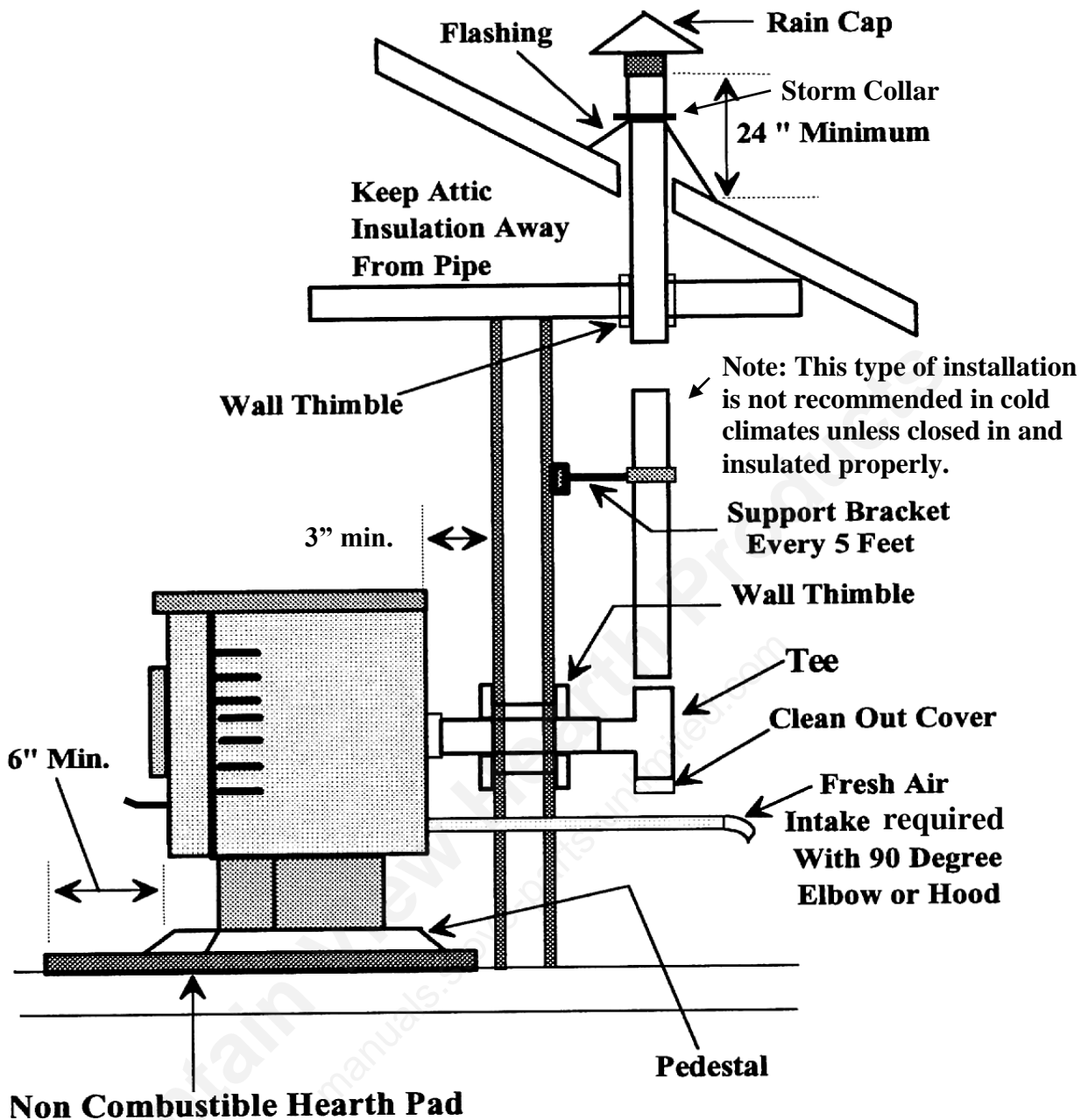

**THROUGH THE WALL, VERTICAL PIPE INSTALLATION WITH TERMINATION THROUGH THE ROOF**

**Warning:** Unless the venting is enclosed and insulated, this installation will cause poor venting, excess ash buildup, premature failure of exhaust system, staining of the house siding and serious creosote buildup. This installation should not be used in a cold climate area.

## AC CONTROL PANEL/THERMOSTAT HOOK-UP

**WARNING: ALWAYS DISCONNECT POWER CORD DURING ANY ELECTRICAL OPERATION**

1. Remove control panel from protective packaging.
2. Connect the one way mox plug to the control panel; do not pull on the wire harness inside the stove.

**NOTE: Use only a low voltage mercury or bi-metal thermostat switch. (No power required on thermostat)**

**NOTE: If you are not going to use the thermostat function then skip steps #4 - #8 and go to Step #9.**

3. Locate the thermostat on a wall six (6') to (10') feet away.
4. Route the wires into the stove near where the AC power cord enters.
5. Pull the thermostat wire through to the control panel cut-out.
6. Move the factory installed jumper from the upper position to the lower position. (see details below)
7. Connect the thermostat wires to the two terminals on the back of the control panel.  
When the room temperature drops below the thermostat setting, the thermostat switch will close, allowing the stove to operate at the medium or higher settings. When the room temperature matches the thermostat setting, the thermostat switch will open, allowing the stove to operate at the low setting.
8. Locate the control panel into the side panel cut-out and secure with four (4) #7 X ½ Phillips screws (supplied). Do not over tighten. Set control board to thermostat operation.
9. The stove is now ready for operation. Refer to the **OPERATING INSTRUCTIONS**.

**Note: The thermostat function of the stove will cycle with the room temperature when the “Fuel Feed Control” is set at a medium or higher setting.**

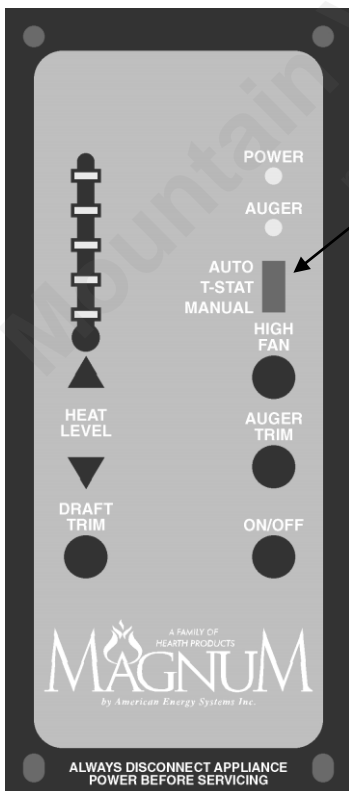

Thermostat controls



Thermostat hookup

# MAGNUM WIN INSERT INSTALLATION

## CLEARANCES - MASONRY FIREPLACES

**FLOOR PROTECTION** - The hearth and floor area underneath the insert, **MUST BE COMPLETELY NON-COMBUSTIBLE, WITH NO WOOD UNDERNEATH.**

The following are clearances to combustibles - **MASONRY FIREPLACE BUILT TO UBC CHAPTER 37.**

### MINIMUM CLEARANCES TO COMBUSTIBLES

- A - Top of stove to mantle..... 15" in.
- B - Side of stove to sidewall..... 12" in.
- C - Side Hearth Extension..... 9" in.
- D - Hearth extension..... 16" in.

### MINIMUM OPENING FOR INSERT INSTALLATION

- E - Height.....21.5" in.
- F - Depth.....16" in.
- G - Width (at front).....30" in.
- Width (at 15 inches depth).....21" in.

### EXHAUST & FRESH AIR LOCATION

#### VERTICAL EXHAUST

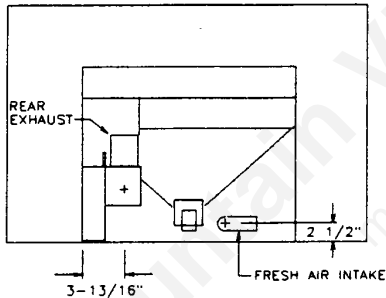

#### HORIZONTAL EXHAUST

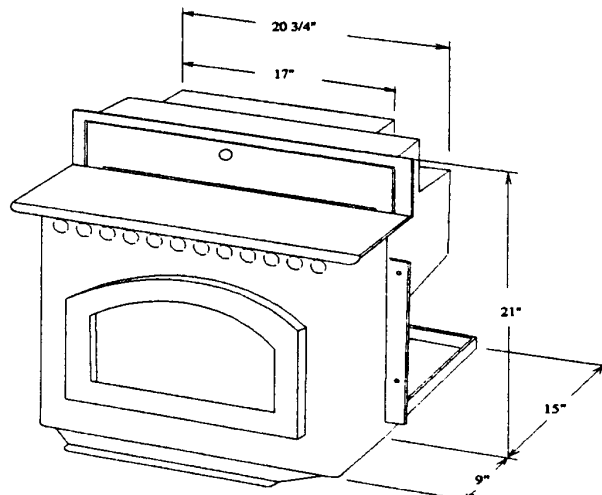
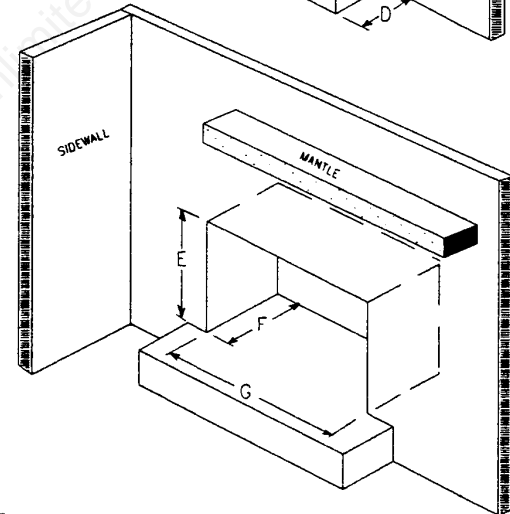
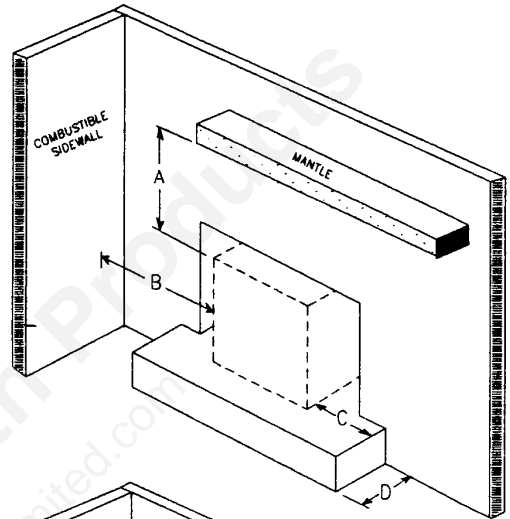
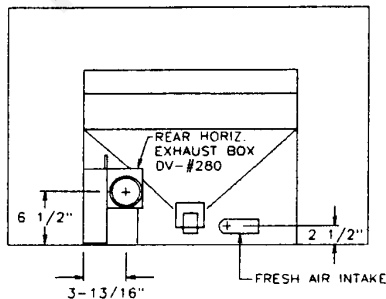

(6)

# WIN INSERT INSTALLATION cont.

## CLEARANCES - FRAMING TO COMBUSTIBLES

**NOTE: DIAGRAMS ARE FOR REFERENCE ONLY. CONSULT WITH A BUILDING CONTRACTOR AND LOCAL BUILDING CODES FOR CONSTRUCTION REQUIREMENTS. FOLLOW THE PIPE MANUFACTURERS INSTALLATION INSTRUCTIONS AND CLEARANCES.**

### INSTALLATION PRECAUTIONS

1. Outside the house, make sure there are no obstructions for the installation of the chase and flue.
2. On the inside of the house, check the wall for the location of existing plumbing and electrical wiring.
3. Locate the wall studs on the inside wall and mark out the finished wall opening. Transfer the wall opening to the exterior wall by drilling pilot holes in the corners of the marked out wall opening. Cut the opening in the walls.
4. The depth of the flue chase will depend on the wall LISTED BELOW.
5. Frame the wall opening and chase according to local building codes.
6. Hearth and hearth extensions must be non-combustible construction as per UBC Chapter 37 for fireplaces and extend 6" inches in front of appliance.
7. Install appliance into the opening, check the clearances to combustibles.
8. Install the flue pipe per manufacturers instructions and clearances. Secure the pipe using wall brackets every 4 feet of pipe.
9. Fire stops must be installed in the chase for each floor level. Install siding on chase.
10. Electrical power is 120-60hz. Do not route the cord in front of, under or along the side of the stove. Do not Remove the grounding prong from the power cord.
11. See OPERATING INSTRUCTIONS for starting your stove.

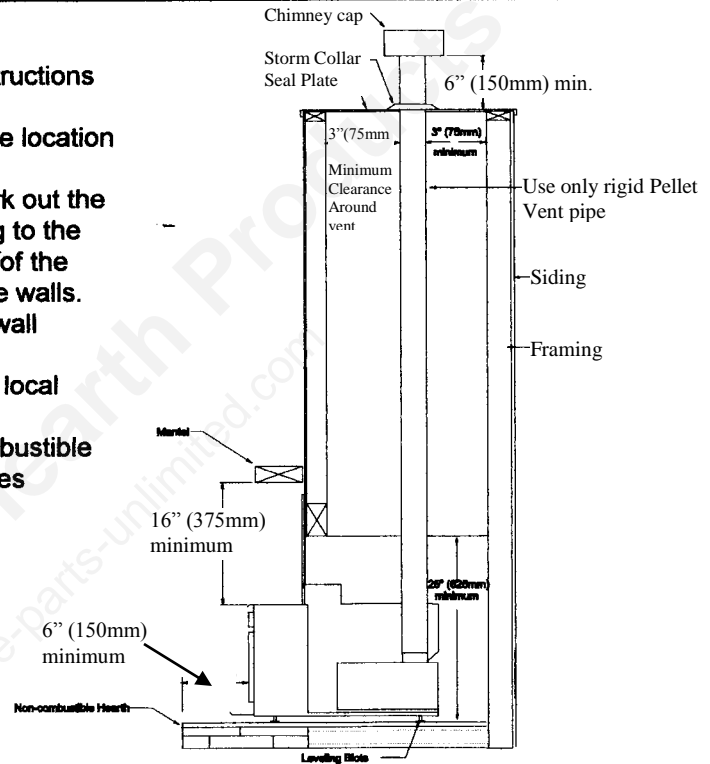

### Minimum Clearances to Combustibles

- |    |                             |            |
|----|-----------------------------|------------|
| A. | Insert to Sidewall.....     | 12 inches  |
| B. | Front Hearth Extension..... | 6 inches   |
| C. | Side Hearth Extension.....  | 9 inches   |
| D. | Side of Stove to Enclosure. | 5.5 inches |
| E. | Opening Height.....         | 25 inches  |
| F. | Opening Depth.....          | 24 inches  |
| G. | Opening Width.....          | 32 inches  |

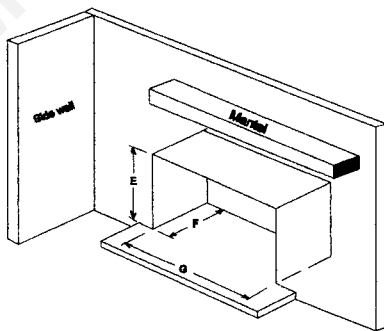

(8)

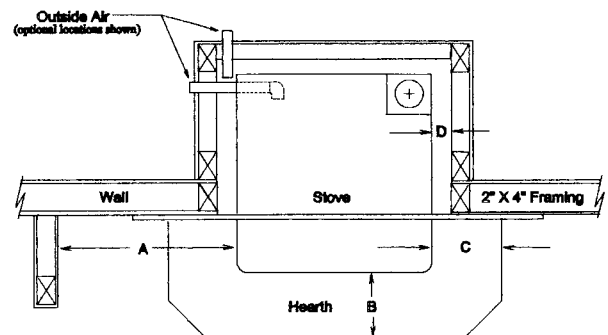

# WIN INSERT INSTALLATION cont.

## CLEARANCES - UL Listed Factory Built Fireplace

**FLOOR PROTECTION** - The hearth and floor area underneath the insert must be continuous non-combustible material such as cement, brick, ceramic tile, or other approved material for floor protection.

The following are clearances to combustibles:

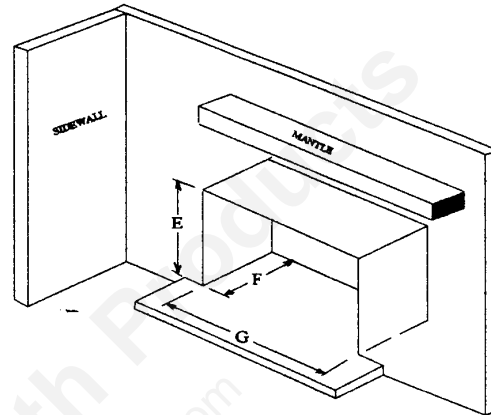
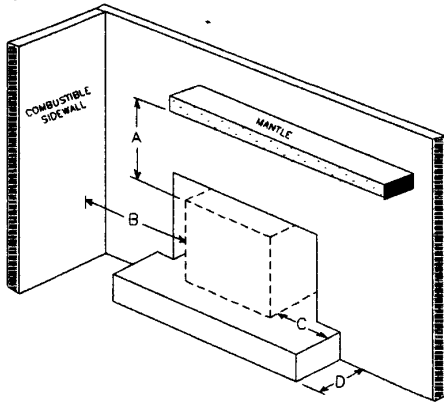

UL Listed Factory Built Fireplace

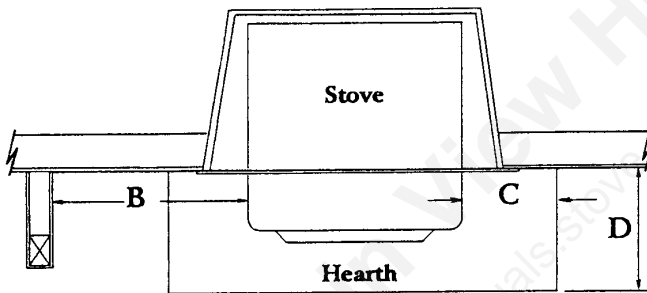

### MINIMUM CLEARANCES TO COMBUSTIBLES

- A - Top of stove to mantel..... 15”In.
- B - Side of stove to sidewall.... 12”In.
- C - Side of hearth extension.... 9”In.
- D - Hearth extension..... 16”In.

### MINIMUM OPENINGS FOR INSERT INSTALLATION

- E - Height..... 21.5” In.
- F - Depth..... 16” In.
- G - Width at front..... 30” In.
- Width at 16” depth...21” In.

**NOTE:**

For a raised Hearth, you can have a decorative skirting made by your installer to finish off the front of the unit. The skirting must be made out of non-combustible materials and must support the weight of the unit.

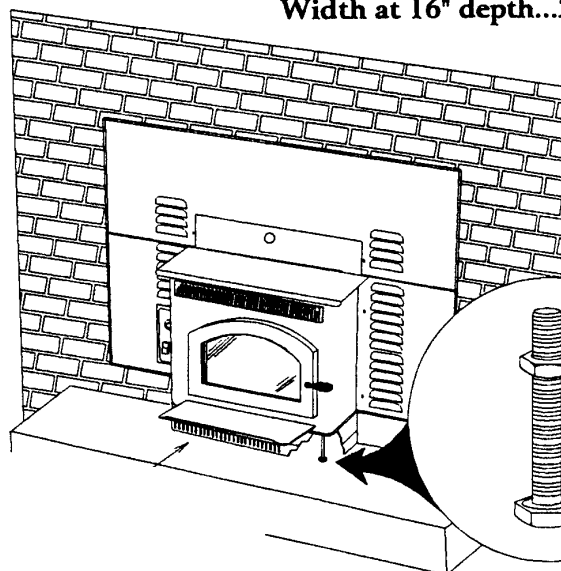

When extending the unit beyond a raised hearth, you must use some type of support bolt to hold and level the unit.  
(not provided)

# INSTALLATION INSTRUCTIONS

## VERTICAL INSTALLATION

The fireplace and chimney should be cleaned before installing. Painting the interior will help seal any odors.

1. Measure the fireplace to determine that the stove will fit to specifications and clearances to combustibles per safety label and clearance section of this manual.
2. Remove or secure the flue damper to the open position.
3. Venting of the exhaust may be terminated 36" above the bottom seal plate or extended to the chimney top.
4. **Extending the exhaust to the chimney top is recommended in all fireplaces.**

## EXTENDING EXHAUST TO CHIMNEY TOP

1. Route 3" flex stainless steel chimney pipe at least 3' beyond the desired termination point to insure enough length for proper connection to the stove flue collar when the stove is positioned in the fireplace opening. (6" min. length of liner is required at top after liner is properly installed).
2. An outside air source must be connected to the stove with 2" diameter Class 0 or Class 1 flexible duct pipe or other metal pipe at least 0.016 inches thick. Fresh air can be brought in through the ash clean-out door, top of chimney, or a hole drilled through the rear of chimney.
3. Measure and install bottom seal plate and top seal plate. Cut out holes for exhaust and combustion air.
4. Seal plates with non-hardening mastic. Place non-hardening mastic around exhaust and fresh air pipe.
5. Install chimney cap on exhaust. Terminate fresh air at top by bending pipe as illustrated. Place 1/4" mesh screen on end of fresh air for rodent guard.
6. Provide or otherwise install 110 volt A.C. power receptacle as required to make the necessary power connections. (In some cases a power source can be brought in through the rear ash door or ash trap in floor)
7. Position the stove in the fireplace and adjust the leveling bolts if necessary.
8. Route power cord out the side of the stove closest to 110V receptacle. **Do not place power cord next to the side of stove. Do not route power cord under the stove.**
9. Place the power cord behind the side panel and use the "channel" created by the mortar joint between brick or rock to route the power cord out of the firebox.
10. Connect the 3" flex stainless steel pipe to the stove flue collar and slide stove back to final position.

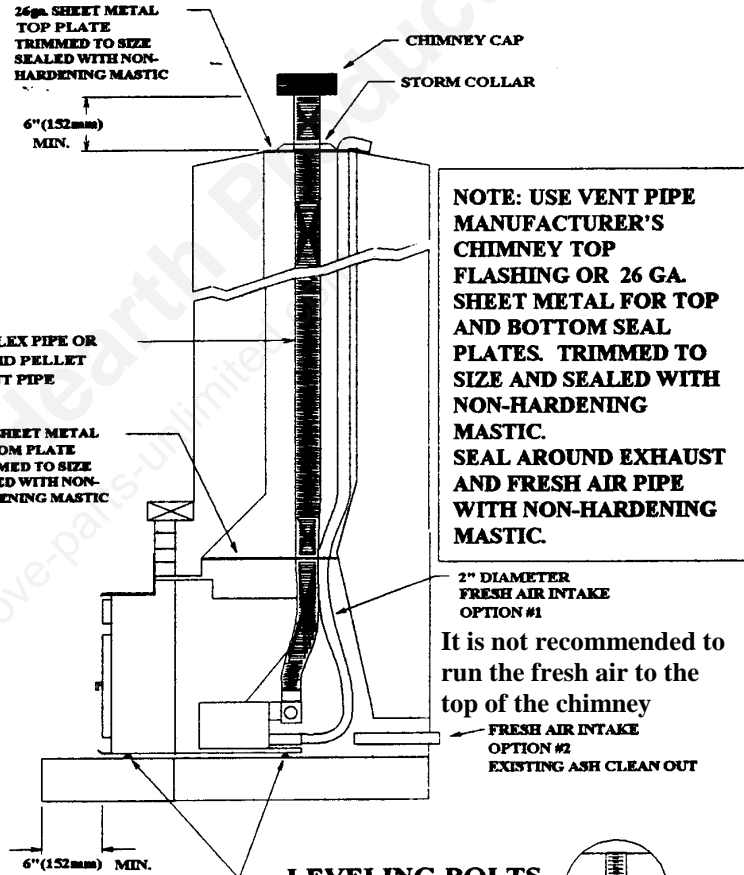

Your installer will determine what type of leveling bolts or other means that will level the unit properly.

It is best to route the fresh air intake either out the back of the fireplace cavity or down and out to an outside air source. Running the fresh air up and out the top of the chimney can cause excessive draft issues.

# INSTALLATION INSTRUCTIONS....Continued

## HORIZONTAL VENT TERMINATION CLEARANCES

EXHAUST VENT TERMINATION SHALL BE AS FOLLOWS:

A MINIMUM OF 4 FEET/1220mm BELOW, BESIDE AND 1 FOOT ABOVE ANY DOOR OR WINDOW THAT OPENS, OR ANY OPENING INTO A BUILDING.

A MINIMUM OF 2 FEET/610mm FROM ANY ADJACENT BUILDING OR OVERHANG.

A MINIMUM OF 7 FEET/2130mm ABOVE GRADE, WHEN LOCATED ADJACENT TO PUBLIC WALKWAYS.

A MINIMUM OF 2 FEET/610mm ABOVE GRASS, PLANTS OR OTHER COMBUSTIBLES.

PLEASE FOLLOW THE PIPE MANUFACTURER'S INSTRUCTIONS AND LOCAL BUILDING CODES FOR THE CLEARANCE TO COMBUSTIBLES REQUIRED FOR INSTALLATION OF THE VENT PIPE BEING USED.

### HORIZONTAL INSTALLATION INTO A MASONRY FIREPLACE

Non-combustible fireplace hearth and hearth extension.

Note: For horizontal venting use Horizontal Vent Adaptor

1. Measure the fireplace to determine that the stove will fit to specifications and clearances to combustibles per safety label and clearance section of this manual. Maintain exhaust termination clearances as shown above.
2. Maintaining the minimum allowable clearances, determine the exhaust and combustion air hole location  
Note: Combustion air may be installed vertically through the chimney cavity.
3. Be careful not to drill or cut into any water lines or electrical wiring as water damage or electrical fire may result.
4. Enlarge the hole as required for the installation of the listed pellet vent pipe.
5. Position the stove in the fireplace and adjust the leveling bolts if necessary.
6. Install the 3" rigid pellet vent pipe through the opening and connect to stove flue collar.
7. Place listed cap on exterior maintaining minimum clearance as shown.
8. Provide or otherwise install 110 volt A.C. power receptacle as required to make the necessary power connections. (In some cases a power source can be brought in through the rear ash door or ash trap in the floor) **Do not route the power cord under the stove. Do not route the power cord next to the side of the stove.**
9. Place the power cord behind the side panel and use the "channel" created by the mortar joint between brick or rock to route the power cord out of the firebox.
10. Install shroud and trim as shown
11. Slide insert back into final position. Do not restrict air flow through vents in the shroud.
12. Route the wiring harness through the cutout on side panel "B"

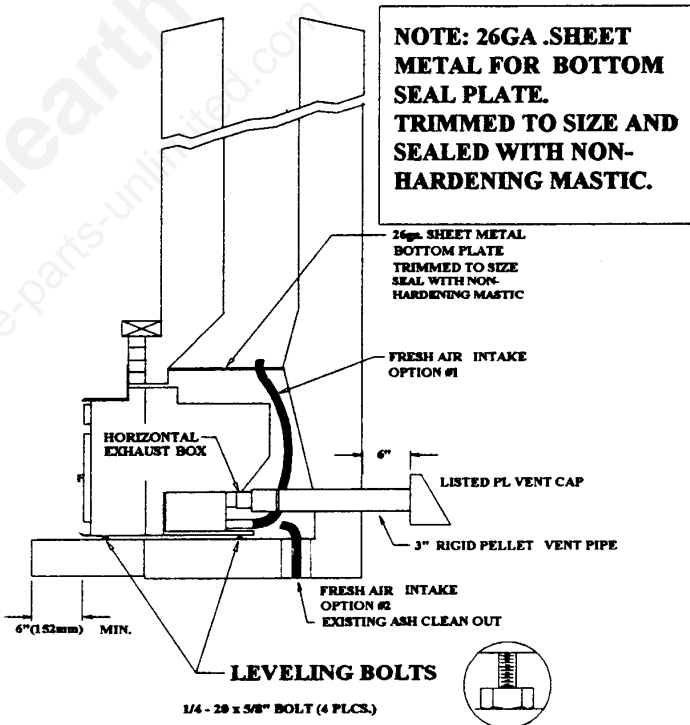

# INSTALLATION INSTRUCTIONS....Continued

## SHROUD and TRIM INSTALLATION

1. Install shroud top "A" to the stove. Align the top with corresponding holes on stove (see diagram below). Fasten with the # 7 sheet metal screws that are provided.
2. Slide the top lip of side panel "B" & "C" under the Shroud Top "A" and align with corresponding holes. Fasten with the # 7 sheet metal screws that are provided (see diagram below).
3. Attach the trim pieces to the sides and top of shroud. Trim may be cut if necessary.
4. Route the wiring harness through the cutout on side panel "B".
5. Slide insert back into final position. Do not restrict air flow through vents in the shroud.

**Do not route power cord under the stove or next to the side of the stove.**  
Place the power cord behind the side panel and use the "channel" created by the mortar joint between the brick or rock to route the power cord out of the firebox.

### Fireplace Insert Shroud Installation Diagram:

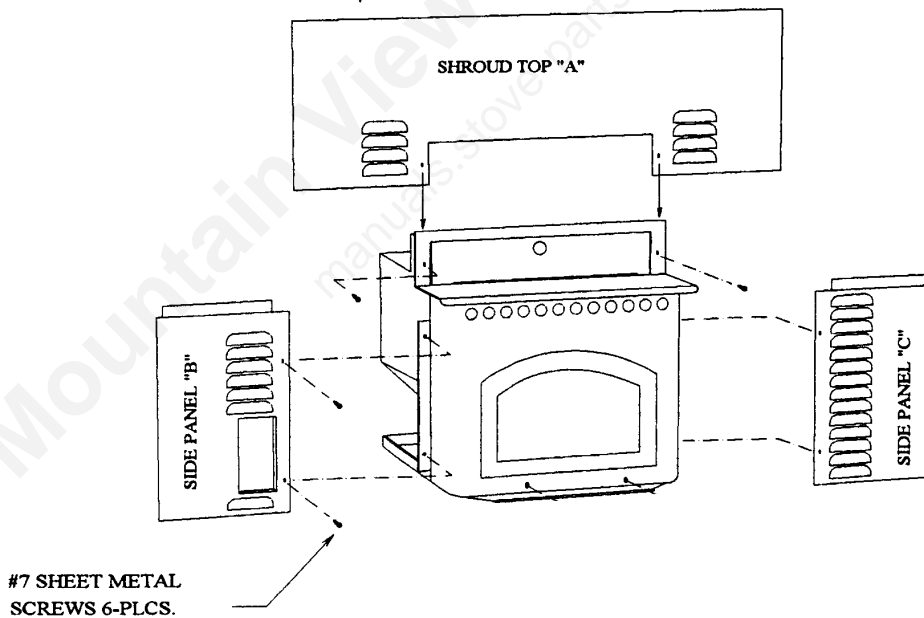

# CONTROL PANEL / THERMOSTAT HOOK-UP

## WARNING: ALWAYS DISCONNECT POWER CORD DURING ANY ELECTRICAL OPERATION

1. Remove control panel from protective packaging.
2. Connect the one way molex plug to the control panel, do not pull on the wire harness inside the stove.
3. Connect the .250 terminal to the .250 terminal spade on the control panel. Do not pull on the terminal wire inside the stove.

**NOTE: Use only a low voltage mercury or bi-metal thermostat switch. (No power required on thermostat)**

**NOTE: If you are not going to use the thermostat function then skip steps #4 - #8 and go to step #9.**

4. Locate the thermostat on a wall six (6') to (10') feet away.
5. Route the wires into the stove near where the AC power cord enters.
6. Pull the thermostat wires through to the control panel cut-out.
7. Move the factory installed jumper from the upper position to the lower position. (see detail below)
8. Connect the thermostat wires to the two terminals on the back of the control panel.  
When the room temperature drops below the thermostat setting, the thermostat switch will close, allowing the stove to operate at the medium or higher settings. When the room temperature matches the thermostat setting, the thermostat switch will open, allowing the stove to operate at the low setting.
9. Locate the control panel into the side panel cut-out and secure with four (4) #7 x 1/2 Phillips screws (supplied). Do not over tighten.
10. The stove is now ready for operation. Refer to the OPERATING INSTRUCTIONS.

**Note:** The thermostat function of the stove will cycle with the room temperature when the "Fuel Feed Control" is set at a medium or higher setting.

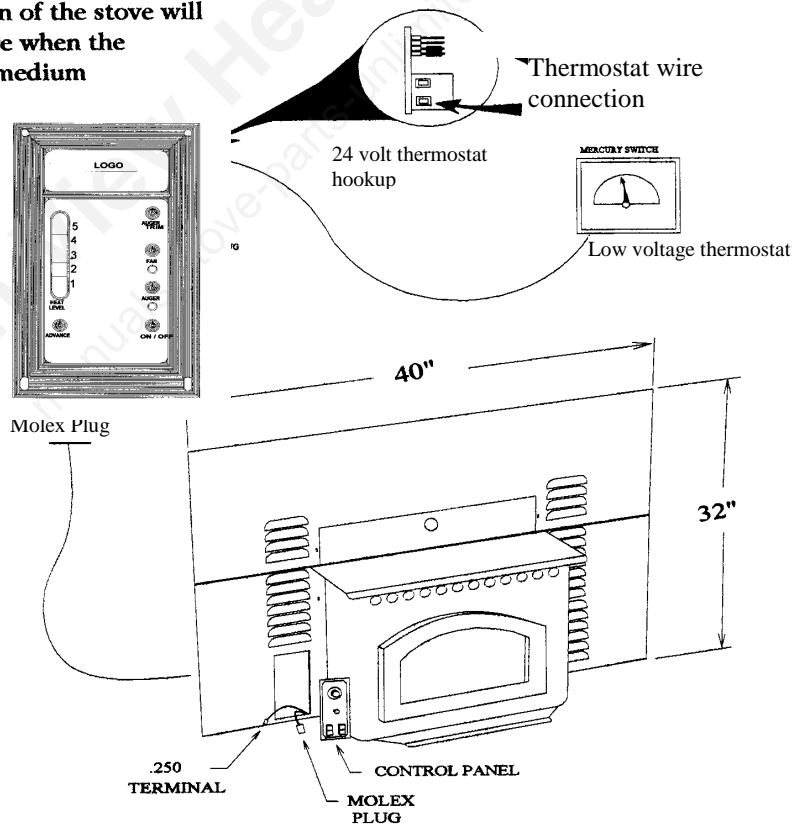

Below is a graphical display of the Magnum RP2016 (Elite) Control Board front panel. Each operational function of the control board is shown for proper operation of the control center.

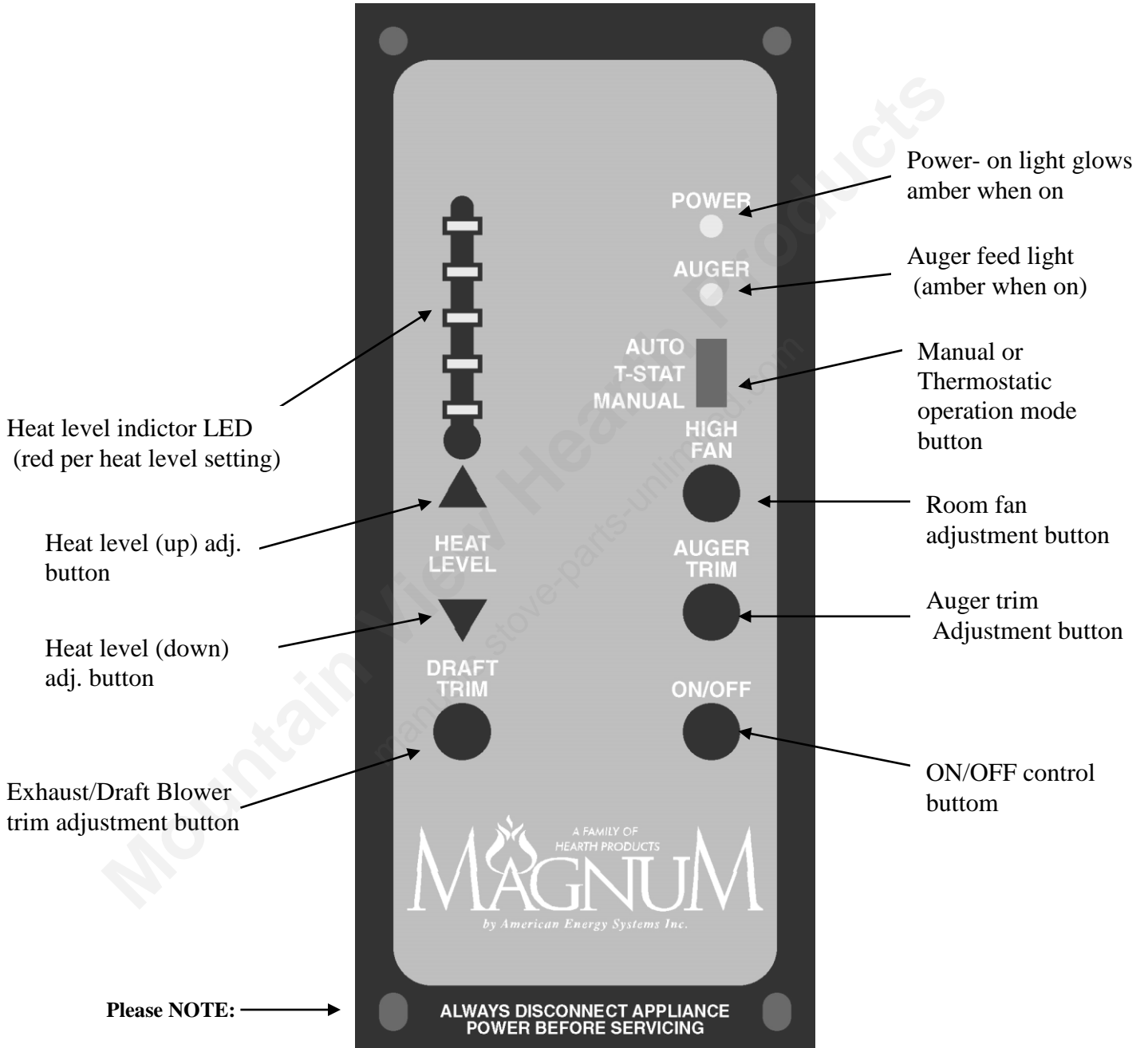

# OPERATING INSTRUCTIONS

## (Using self igniter systems, if auto ignition system (optional) has been installed)

**NOTE: Each time the stove is started, the firepot must be checked for debris and clear air holes. Some fuels will cause the firepot to build up more frequently making it necessary to stir and clean the firepot more often. Do not allow ash to build up underneath the firepot area or in the ash pan as it will block off the air flow to the firepot.**

Your control panel has three (3) separate modes of operation (switch located on top of board). The MANUAL setting allows the operator to choose heat level setting changes without a thermostat. The T-STAT setting allows the operator to set the highest heat level setting desired and when the thermostat is satisfied, the unit will automatically go to the low heat level setting. The AUTO setting allows the unit to shut completely off when the thermostat is satisfied and re-start when the thermostat calls for heat. The AUTO setting can only be used with **Biomass Fuels or a 50/50 mix of corn and Biomass Fuels.**

Before lighting your Magnum for the first time make sure that all items are out of the hopper and firebox area. Note: If using a wall thermostat, make sure that the thermostat is turned up above room temperature. The unit will operate on low fire if the thermostat is turned down.

- ✓ Load the hopper with fuel (Corn or Biomass Fuels).
- ✓ Close the door
- ✓ Push the “On/Off” button.
- ✓ Turn the air intake butterfly damper to approximately ¼ inch open. (More or less as needed.)

**NOTE:** Priming the auger is required when the unit is new or when the hopper has completely run out of fuel. This can be done approximately 1 minute after pushing the on/off start button. Press and hold the “auger” button until fuel begins to drop into the firepot. When fuel begins to drop regularly, release auger button, the auger is primed.

**NOTE:** The viewing door, ash pan door and hopper door must be closed and/or latched during operation or vacuum will not be established. If vacuum can not be established the stove will shut down and the #2 heat level setting light will blink. The ON/OFF button must be held for app. 6 seconds to reset.

The unit starts automatically on a pre-set heat level setting. After the unit has been turned on, and the 1 minute diagnostics has run, you may select a desired heat level. However, the heat level feed rate will not change until the unit has completed the 15 minute startup sequence. It is recommended to burn the unit on the number #2 or #3 heat level setting for the first 30-45 minutes.

If the fire temperature has not reached proper operating temperature within the minimum cycle time (15 min.) the auger will stop feeding, the stove will shut down and the #3 heat level setting light will blink. You will need to press and hold the ON/OFF button for 6 seconds to start the cycle over again. If the system is set on auto start it will attempt two startups on its own.

The draft and room air blower speed varies with each feed rate. The “Draft Trim” button will override the variable fan function +/- 5 volts on all heat levels. To override, press and hold the “Draft Trim” button along with the heat level button arrow up or heat level button arrow down, depending on desired change.

The auger feed rate on each setting is pre-programmed but may be changed if necessary. The “Auger Trim” button will override the programmed feed rates by +/-5% on all heat levels. To override the feed rate press and hold the ‘Auger Trim’ button along with the heat level button arrow up or heat level button arrow down, depending on desired change.

**NOTE: In case of a power outage or interruption lasting longer than 5 seconds, the “On/Off” button must be pushed and held for app. 6 seconds to re-engage the auger. If needed re-light the unit.**

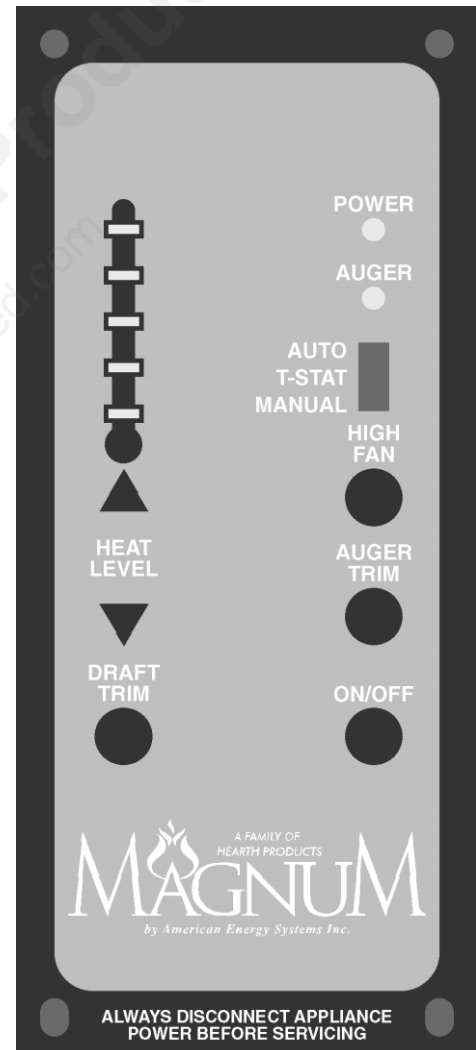

**NOTE:** If the fire is burning too fast and the fuel is being burned up too quickly, turn the air intake butterfly damper closed a little to slow the fire down. This should be done in small 1/4" increments so that the fire doesn't change too quickly. You can also adjust the draft or auger trim to balance out the burn rate.

**NOTE:** When changing the heat levels there will be a delay so the system can complete the cycle before switching to the new heat level.

**NOTE:** In case of a power outage, the pressure switch has tripped, the door has been opened, the hopper door has been left open or any power interruption lasting longer than 5 seconds, the "On/Off" button must be pushed and held for app. 6 seconds (or until you here a click) to re-engage the auger system.

**IMPORTANT:** The circuit board will not function properly if the outlet is not a constant 120 volt, 60 cycle power source. The outlet must be grounded properly and have the correct polarity. A polarity and ground tester can be picked up at any hardware store to assure proper operation. If you are using a power generator, solar power or wind generation make sure that you have a constant correct power source.

The unit's electrical warranty would become void if a constant power source is not available. Also make sure that a proper surge protector is between the unit and the power source. The circuit board will not be warranted if there is not a surge protector installed to the unit.

It is strongly recommended that you unplug the power source during times when the unit is not being operated to protect the unit from power surges, power spikes and drops in power. It is very common for a circuit board to work when the unit is shut off in the spring and then won't work in the fall. Unplugging the unit will prevent this from happening.

## OPERATING INSTRUCTIONS

(Without using system igniter)

**NOTE:** Each time the stove is started, the firepot should be checked for debris and clear air holes. Some fuels will cause the firepot to build up more frequently making it necessary to stir and clean the firepot more often. Do not allow ash to build up underneath the firepot.

Your control panel has three (3) separate modes of operation (switch located on top of board). The MANUAL setting allows the operator to choose heat level setting changes without a thermostat. The T-STAT setting allows the operator to set the high heat level setting and when the thermostat is satisfied, the unit will automatically go to the low heat level setting. The AUTO setting allows the unit to shut completely off when the thermostat is satisfied and re-start when the thermostat calls for heat. The AUTO setting can only be used with Biomass Fuels.

Before lighting your Magnum for the first time make sure that all items are out of the hopper and firebox area. Note: If using a wall thermostat, make sure that the thermostat is turned up above room temperature. The unit will operate on low fire if the thermostat is turned down.

- ✓ Load the hopper with fuel (Corn or Biomass Fuels).
- ✓ Place a small handful of Biomass Fuels or fire starter in the firepot.
- ✓ Squirt a small amount of fire starter gel on top of the Biomass Fuels. (Evenly across the Biomass Fuels)
  
- ✓ Light the fire starter gel.
- ✓ Close the door
- ✓ Push the "On/Off" button.
- ✓ Turn the air intake butterfly damper to approximately 1/4 inch open. (More or less as needed.)

**NOTE:** Priming the auger is required when the unit is new or when the hopper has completely run out of fuel. This can be done approximately 1 minute after pushing the on/off start button. Press and hold the "auger" button until fuel begins to drop into the firepot. When fuel begins to drop regularly, release auger button, the auger is primed.

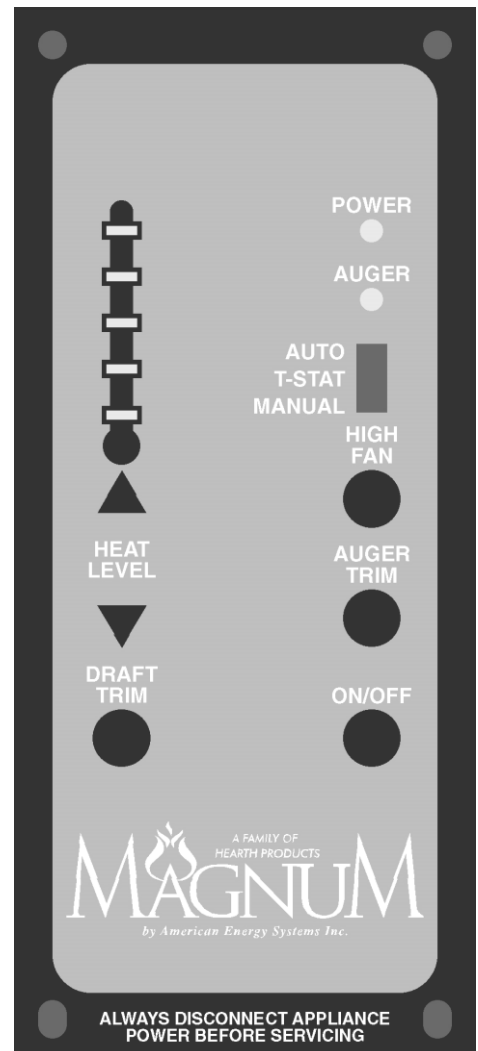

**NOTE:** The viewing door, ash pan door and hopper door must be closed and/or latched during operation or the vacuum will not be established. If vacuum can not be established the stove will shut down and the #2 heat level setting light will blink. The ON/OFF button must be pushed and held for app. 6 seconds to reset the system.

The unit starts on a pre-set heat level setting. After the unit has been turned on you may select the desired heat level. However, the feed rate heat level will not change until the unit has completed the 15 minute startup sequence. It is recommended to burn the unit on the number #2 or #3 heat level setting for the first 30-45 minutes.

If the fire temperature has not reached proper operating temperature within the minimum cycle time (15 min.) the auger will stop feeding, the stove will shut down and the #3 heat level setting light will blink. You will need to press and hold the ON/OFF button for 6 seconds to start the cycle over again. If the system is set on auto start it will attempt two startups on its own.

The draft and room air blower speed varies directly with the feed rate. The “Draft Trim” button will override the variable fan function +/- 5 volts on all heat levels. To override, press and hold the “Draft Trim” button along with the heat level button arrow up or heat level button arrow down, depending on desired change.

The auger feed rate on each setting is pre-programmed but may be changed if necessary. The “Auger Trim” button will override the programmed feed rates by +/-5% on all heat levels. To override the feed rate press and hold the ‘Auger Trim’ button along with the heat level button arrow up or heat level button arrow down, depending on desired change.

**NOTE:** In case of a power outage or interruption lasting longer than 5 seconds, the “On/Off” button must be pushed to re-engage the auger. If needed re-light the unit.

**NOTE:** If the fire is burning too fast and the fuel is being burned up too quickly, turn the air intake butterfly damper closed a little to slow the fire down. This should be done in small 1/4” increments so that the fire doesn’t change too quickly. You may also adjust the draft and auger trim to balance the burn rate.

**NOTE:** When changing the heat levels there will be a delay so the system can complete the cycle before switching to the new heat level.

**NOTE:** In case of a power outage, the pressure switch has tripped, the door has been opened, the hopper door has been left open or any power interruption lasting longer than 5 seconds, the “On/Off” button must be pushed and held for app. 6 seconds (or until you here a click) to re-engage the auger system.

**IMPORTANT:** The circuit board will not function properly if the outlet is not a constant 120 volt, 60 cycle power source. The outlet must be grounded properly and have the correct polarity. A polarity and ground tester can be picked up at any hardware store to assure proper operation. If you are using a power generator, solar power or wind generation make sure that you have a constant correct power source.

The unit’s electrical warranty would become void if a constant power source is not available. Also make sure that a proper surge protector is between the unit and the power source. The circuit board will not be warranted if there is not a surge protector installed to the unit.

It is strongly recommended that you unplug the power source during times when the unit is not being operated to protect the unit from power surges, power spikes and drops in power. It is very common for a circuit board to work when the unit is shut off in the spring and then won’t work in the fall. Unplugging the unit will prevent this from happening.

# OPERATING INSTRUCTIONS...continued (ALL MODELS)

## PROPER FUEL

This stove is designed and approved to burn Super or Premium Biomass fuels only. Do not use any other type of fuel. Clean corn with moisture content less than 15% must be used. Factory approved pellets are those ¼” in diameter and not over 1” in total length. Larger pellets will cause the auger to jam or bridge in the pellet hopper. The use of unapproved fuel will void all warranties. Do not burn damp or wet pellets. The stove’s performance depends greatly on the quality of your pellet fuel.

**Clean fuel means a consistent and trouble-free operation. Do not use corn/Biomass Fuels that have:**

1. **Excess fines**-loose material that looks like sawdust or sand. Loading this material into the hopper may eventually slow down or jam the auger and prevent the flow of fuel in the hopper compartment. Dirty Corn (corn cobs, cockle burrs, etc. will plug the auger)
2. **Binders**-material used to hold the pellet together. Wax content corn cannot be used.
3. **High ash content**-avoid pellet brands that immediately smoke up the viewing window and leave a residue in the burn pot. You will be required to clean the ash boxes and vent pipe more frequently. It may be necessary to sample several brands until you find a brand of pellets that will burn properly. Corn supply must be clean, consistent and preferred 11-12% moisture.

## RUNNING YOUR STOVE

- A. After the start-up cycle has been completed, leave the stove burning on the #2 or #3 setting for at least 20-30 minutes to allow the stove to heat to operating temperatures. You may then set the desired burn rate by moving the control center to the desired operating position.
- B. Select the most efficient burn by adjusting the air damper control rod. An air damper closed too much will produce a lazy and slow flame. Adjusted properly, the flames should be bright and lively. Altitude and fuel types greatly affect the amount of air required. Opening the damper approximately ¼-1/2 will be sufficient for most installations and fuels. **The operating temperatures of this unit may vary with the different types or grades of fuel used. Feed rates and therefore BTU values can vary 30-40%.**

## TURNING THE STOVE OFF

- A. Push the On/Off button momentarily. The fan will continue to run for approximately 45-60 minutes to let the stove cool down, and then automatically shut itself off.

**NOTE: IF THIS UNIT RUNS OUT OF FUEL AND COOLS DOWN, THE AUGER WILL STOP FEEDING. IT WILL BE NECESSARY TO PRIME THE AUGER ANY TIME THE HOPPER RUNS OUT OF FUEL. THE BLOWERS WILL CONTINUE TO RUN UNTIL THE LOW LIMIT SENSORS OPEN AND SAFELY SHUT THE SYSTEM OFF.**

**WARNING: DO NOT USE ADDITIONAL GRATES TO SUPPORT THE FUEL.**

**WARNING:** Auger jams are the leading cause of stove malfunctions. Jams occur due to foreign objects in the fuel, or more commonly, failure to follow the operating instructions. Most auger jams are preventable by properly priming the auger as required before starting the stove. Keeping the hopper from running out of fuel will help prevent auger jams.

**IMPORTANT:** Selecting the proper combustion air is done by moving the air damper control rod in or out to decrease or increase the air flow (in = closed = decrease, out = open = increase). High altitude or high ash fuel may require more air for efficient fuel combustion. The stove should be started with the damper control rod out in the 1/4 open position.

# CLEANING INSTRUCTIONS

**NOTE: BE SURE THE STOVE IS TURNED OFF, THE POWER CORD IS UNPLUGGED, AND THE UNIT IS COLD BEFORE CLEANING OR SERVICING.**

## RECOMMENDED CLEANING PERIODS:

- A. The heat exchange tubes in the stove should be cleaned 1 to 2 times per day.
- B. The firebox/ash pan should be cleaned every 1 to 3 days or when needed.
- C. The interior ash chambers should be inspected and cleaned monthly or as needed.
- D. The chimney pipe and cap should be checked every 2-4 weeks for soot buildup.
- E. Combustion/room blower cleaned as needed. Check monthly, clean semi-annually.
- F. Hopper vacuumed out weekly or more often if fuel has a lot of fines, dirt, cobs, etc.
- G. Glass cleaned as needed or weekly. Do not use petroleum products or clean hot.

## DISPOSAL OF ASHES:

Ashes should be placed in a metal container with a tight fitting lid. The closed container of ashes should be placed on a noncombustible floor or on the ground, well away from all combustible materials, pending final disposal. If the ashes are disposed by burial in soil or otherwise locally dispersed, they should be retained in the closed container until all cinders have been thoroughly cooled.

**WARNING: MANY HOME VACUUM CLEANERS ALLOW ASH TO ESCAPE INTO THE ROOM AIR; HOWEVER, VACUUMING (Use an approved Ash vacuum system.) IS RECOMMENDED OCCASIONALLY TO AID IN SEASONAL CLEANING AND KEEP THE UNIT FREE OF EXCESS ASH. DISCARD THE VACUUM BAG AFTER EACH USE ON THE STOVE.**

## FIREBOX: This needs to be done every 3-7 days depending on fuel quality, heat settings.

Shut off unit and let cool, open the door, sweep or vacuum out the ash buildup. Remove the firepot and empty, inspect all air holes and clean if blocked. Inspect under the firepot for buildup of ash. Replace the firepot in the stove. Periodically inspect the ash chambers "A", "B", and "C" by removing the inspection doors. If the heat exchangers become plugged remove the three (3) wing nuts, bracket and brick panels. The ash chambers can be removed from the firewall for a more thorough cleaning.



## BACK ASH CHAMBER AREA: Every 2-4 weeks

Periodically inspect the back ash chambers to make sure that they have not plugged. Contact your local dealer for the proper cleaning tools. Clean out any obstruction that would cause the ash to not drop out of the chamber. There is a clean out plug behind the ash pan that needs to be inspected once a month.

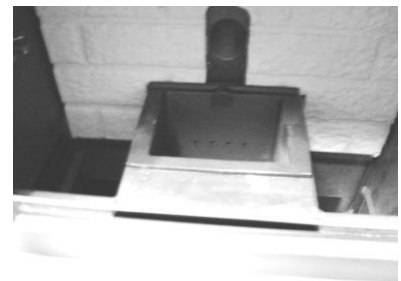

## ASH PAN: Empty as needed.

Empty the ash pan before it overflows with ash. Clean out the area that the ash pan sits in so that the ash pan can go back to its original location.

**NOTE:** The ash pan door must be latched for the unit to operate.

**WARNING: Failure to clean the stove is a leading and preventable cause of stove malfunctions. Fuel types and installations may dramatically affect the cleaning intervals required for your stove. Sampling different brands of fuel to find the cleanest burning fuel available in your area can greatly reduce the amount of maintenance required.**

**HEAT EXCHANGER:**

This stove is designed with a built-in heat exchange rake. The rake handle is located on the front of the stove and is moved backwards and forwards several times to remove the buildup of ash. After cleaning, push the rake handle in until it stops.



**Ash Rake Handle**

**COMBUSTION BLOWER:**

Over the course of the heating season dust and ash may collect on the blades of the combustion blower. Periodically they should be inspected, vacuumed, and clean. The combustion blower is accessed by opening the stove's right side panel and then removing the inspection caps or the exhaust manifold cover (See figure to the right). Never operate the stove without the inspection cap or manifold cover in place.

**250 Manual Reset  
High Temp Shut Off  
Auger Thermodisk**

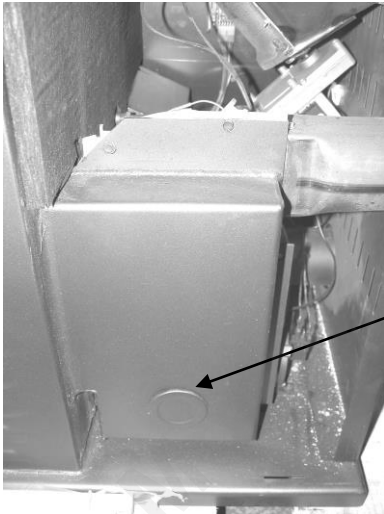
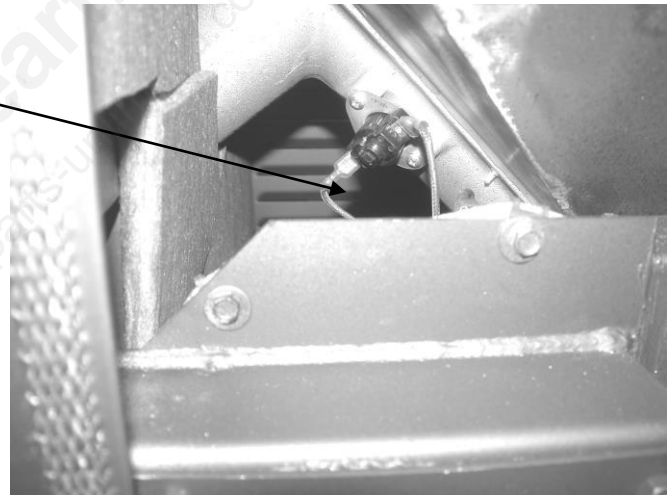

**Inspection Cap**

**Auto Reset  
110 deg Normally open  
Cool Down**

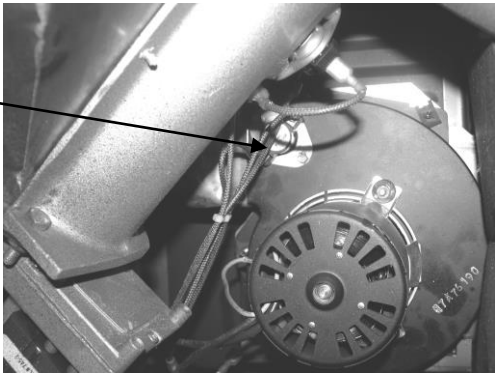

The convection (room air fan) blower will accumulate dust, pet hair, etc. on the blades during the heating season. This must be vacuumed and clean as needed. If you have pets, the convection blower will need to be cleaned regularly as the pet hair will clog up the blades and motor windings and cause premature wear, overheating and failure of the blower system.

# CLEANING INSTRUCTIONS FOR THE WINCHESTER INSERT

**WARNING: DISCONNECT THE POWER CORD BEFORE CLEANING OR SERVICING THIS UNIT. THE STOVE MUST BE TURNED OFF COOLED BEFORE USING THE RAKE HANDLE.**

## II. HEAT EXCHANGER:

This stove is designed with a built-in heat exchange tube rake. The ash rake handle is located on the front of the stove and is moved backwards and forwards several times to remove the buildup of ash. After cleaning, push the rake handle in until it stops.

## III. COMBUSTION BLOWER:

Over the course of the heating season dust and ash may collect on the blades of the combustion blower. Periodically they should be inspected and vacuumed clean. The combustion blower is accessed by removing the inspection caps or the exhaust manifold cover (See figure below). Never operate the stove without the inspection cap or manifold cover in place.

## IV. VENT EXHAUST BOX:

The vent exhaust box is accessed by removing the inspection cap (See figure below). Periodically it should be inspected and vacuumed clean.



Manual reset 225 deg.  
Normally closed high temp  
disc

The convection (room air fan) blower will accumulate dust, pet hair, etc. on the blades during the heating season. This must be vacuumed and clean as needed. If you have pets, the convection blower will need to be cleaned regularly as the pet hair will clog up the blades and motor windings and cause premature wear, overheating and failure of the blower system.

## INSERT CLEANING INSTRUCTIONS...continued

**WARNING: DISCONNECT POWER CORD BEFORE CLEANING OR SERVICING.**

**NOTE: CLEANING INTERVALS MAY VARY GREATLY WITH DIFFERENT TYPES/BRANDS OF FUEL DUE TO THE ASH CONTENT, MOISTURE, AND MATERIAL COMPOSITION OF DIFFERENT FUELS.**

### INSPECT AND CLEAN EXHAUST SYSTEM FREQUENTLY

	DAILY	WEEKLY	MONTHLY	ANNUALLY
<b>FIREPOT</b>	Stirred Emptied	CLEANED		
<b>FIREBOX (BURN CHAMBER)</b>	CHECKED	CLEANED		
<b>ASH CHAMBERS</b>	CHECKED	CLEANED	EXTRA CLEANING	
<b>EXCHANGER TUBES</b>	CLEANED	EXTRA CLEANING		
<b>COMBUSTION FAN</b>			INSPECTED	CLEANED
<b>VENTING SYSTEM</b>		CHECKED	CLEANED	
<b>GASKETS</b>			INSPECTED	
<b>DOOR GLASS</b>		CLEANED	INSPECTED	

### V. CHIMNEY CLEANING:

- A. **Creosote Formation** - Any time wood or a wood product is burned slowly, tar and other bi-products of combustion are produced. These products can condense in a cooled chimney flue and will accumulate over a period of time. It is important to remove these products periodically to eliminate the possibility that they will be ignited in the chimney and produce damage to the chimney or even possibly destroy the home. Clean the chimney as often as needed and never go more than one (1) year without a flue cleaning.
- B. **Soot and Fly Ash - Formation and Need for Removal** - The products of combustion will contain small particles of fly ash. The fly ash will collect in the exhaust venting system and restrict the flow of the flue gases. Incomplete combustion, such as it occurs during startup, shutdown, or incorrect operation of the stove will lead to some soot formation which will collect in the exhaust venting system. The exhaust venting system should be inspected at least once every year to determine if cleaning is necessary.
- C. **Inspection and Removal** - The chimney connector and the chimney should be inspected to eliminate the risk of a chimney fire. Check the chimney from both the top and bottom. The creosote should be removed with a brush designed for your chimney. A chimney sweep can perform this service. It is recommended that before each heating season the entire system be professionally inspected, cleaned, and repaired if necessary.

## AUTOMATIC FEATURES

- A. THERMOSTAT OPTION (Optional):**  
When using a thermostat, set the unit to one of the medium or higher settings. The unit will burn at the rate selected on demand by the thermostat (medium to high). When the room temperature drops below the thermostat setting, the thermostat switch will close, allowing the unit to operate at the medium or higher settings. When the room temperature matches the thermostat setting, the thermostat switch will open, allowing the stove to operate at the low setting.
- B. THERMOSTAT EQUIPMENT REQUIRED (is optional):** A low voltage millivolt thermostat that will automatically switch between settings previously selected. Type CL2 thermostat wire-20 AWG, 2 conductors.
- C. VACUUM PRESSURE SWITCH/STOVE PRESSURE SENSOR:**  
A blocked flue, a down draft, open door, open hopper lid, negative or positive pressure in the home, drafty location of the appliance, not hooking up the outside air, improper venting or maintenance of the 3” exhaust venting from the stove will cause the pressure switch to shut off the auger. To resume operation, it is necessary to locate the cause and correct it. Restart the unit following the instructions in this manual.
- D. HIGH TEMP THERMODISK/SNAP DISK:**  
If the unit overheats, it will shut itself down safely. The unit may not be restarted until it has cooled and the reset button is depressed. (See Thermodisk location section) If the auger does not turn after cleaning the back of the unit, you might have tripped this disk. To reset high temp push in on the center button until it clicks into place.
- E. SELF-IGNITER (Optional):**  
Automatically ignites the pellets within 3-5 minutes, without the use of fire starter. The igniter will continue to run for approximately 12 minutes until a fire is established. If the fuel is wet, poor quality or the hopper has not been primed, it might take 2 or 3 cycles for the unit to properly light. Using a small amount of fire starter will help with this.
- F. PROOF OF FIRE THERMODISK/SWITCH/SNAP DISK:**  
If the temperature required by the PROOF OF FIRE thermodisk is not high enough within the 10 (15 minutes on the AC models) minute cycle, the auger will stop feeding fuel.
- G. COOL DOWN SENSOR/SWITCH/LOW LIMIT: (Same as Proof of Fire Thermodisk)**  
After the power switch has been moved to the “OFF” position, the blowers will continue to run for approximately 45 minutes. The cool down sensor will allow the stove to cool down and then automatically shut itself off. If the hopper runs out of fuel and the stove cools off, the auger will stop feeding. However, the blowers will continue to run until the POF switch has cooled down to initiate the shut down cycle

## GLASS MAINTENANCE, ADJUSTMENT, REMOVAL AND REPLACEMENT

Your **MagnuM Biomass Pellet Stove** comes to you with the glass door installed in place, ready for use. The glass is surrounded on the edges with a gasket and seated in a glass channel. It is held in place with two (2) clips on the top and two (2) clips on the bottom and two (2) clips on each side.

### **REMOVAL OF BROKEN OR DAMAGED GLASS**

Open the door and lift it off of hinges. If the door is tight, tap gently on the bottom of the door with your hand or rubber hammer. Lay door on newspaper with glass clips facing you. Using a #2 Phillips screwdriver, loosen the screws and take the glass clips off. Remove the broken glass carefully and discard. Check to insure that the gasket material under the glass is in working order. You can obtain this material from the factory or from an authorized **MagnuM** reseller if it is in need of replacement.

Reverse the above procedure for replacing the new glass. **When installing the new glass insure that the glass is not sitting on top of any obstructions. The glass will break when tightening the screws if the glass is on the gasket. Hold the glass toward the top of the door glass channel when tightening.**

### **WARNING**

**Do no operate unit with broken glass.  
Do not substitute original factory glass.  
You must use only factory authorized glass:  
Do not slam door shut.  
Do not strike glass.  
Do not use abrasive cleaners.  
Do not clean when glass is hot.**

### **CLEANING THE GLASS**

When the fire is first started, it will produce some smoke. The smoke might accumulate on the glass surface. Before the fire gets hot, open the door and wipe the glass surface off with a damp rag. Do not touch the surface with your hands. If after constant use, the glass is dirty; you must clean the glass so that it will not become etched with the fly-ash. When the glass has cooled off, take a damp rag, put a little fly ash from the unit on it and clean the glass. If this does not clean the glass use a special glass cleaner provided by your **MagnuM** reseller. **We have found that Amway's Crème Glass & Chrome Cleaner works very well.**

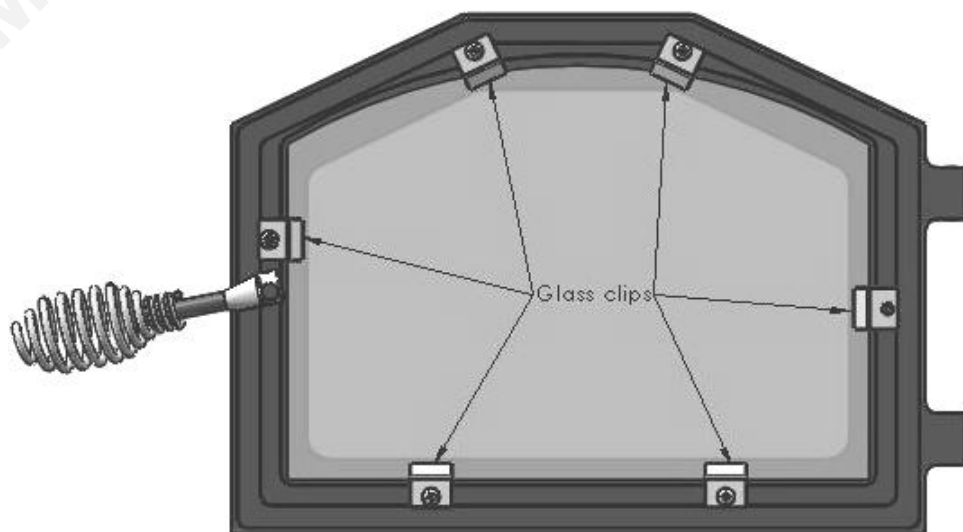

**Before starting the Magnum Biomass unit again, it is important to remember to clean out the firepot, empty the ashes, clean out the heat exchangers, vacuum out the hopper if needed and fill the hopper with fuel.**

## Basic Circuit Board Functions (expanded)/Diagnostics Operation

The ON/OFF button initiates the start of the circuit board and the shut down of the board. Pushing the ON/OFF button momentarily will engage the start up sequence. The ON/OFF button also is used to re-set the board when the vacuum switch or proof of fire switch is tripped. Pushing the ON/OFF button until the board re-sets (usually 6-7 seconds) will re-establish the system and the fire will continue unless there is a failure in the electrical components.

When you push the ON/OFF button to start the unit, power light will be on and the start up sequence will take approx. 12-15 min. During the start up sequence, the fuel level setting will be over ridden and the unit will feed at the pre-set fuel rate setting. After the start up sequence has been established (approx. 12-15 min.) the unit will run at whatever fuel level setting you selected. The number #2 or #3 heat level setting is recommended for the 1<sup>st</sup> 30-45 minutes.

The auger light will flash when the auger is running. On the wood setting the auger will start right away. If on the corn setting there is a (1) minute delay prior to starting. You can hold the auger button down to override the system and manually prime the auger.

The room fan button will override the # 1 heat level setting fan speed and go to high speed. This will not change the fan speed on the #2 - #5 heat level settings.

The auger trim button allows for a low/high fuel setting fine tune adjustment on the all 5 settings. When pushing the auger trim button select either the heat level up button or heat level down button depending on the fine tune requirements.

The draft trim allows for a low/high setting fan speed and go to a lower or higher setting depending on requirements. When pushing the draft trim button select either the heat level up button or the heat level down button to fine tune fan speed.

The heat level setting button is a manual heat adjustment. Pushing the heat level setting button will advance the heat settings one level each time that it is pushed. The LED light will show which heat level setting the unit is on. At start up, regardless of where the heat level setting button is set, the unit will feed on the pre-set heat level setting. Once the start up sequence has been established, the fuel feed rate setting will run at whatever fuel level setting you selected.

During a short power outage, the board will detect if the proof of fire switch is engaged. If it is still engaged (closed) the unit will auto re-start.

### Shutdown

To shut the unit down, simply press the On/Off button. The room fan and exhaust blower will continue to operate until the low limit/cool down sensor tells it that the fire is out. At that point the exhaust fan will continue to run for an additional 15 minutes to make sure there is no exhaust in stove.

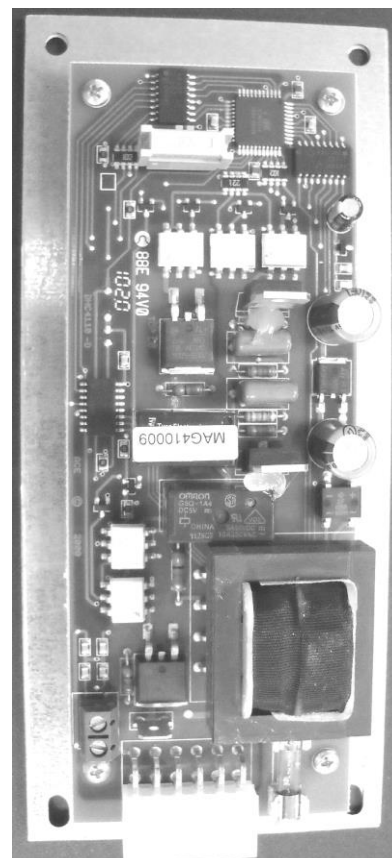
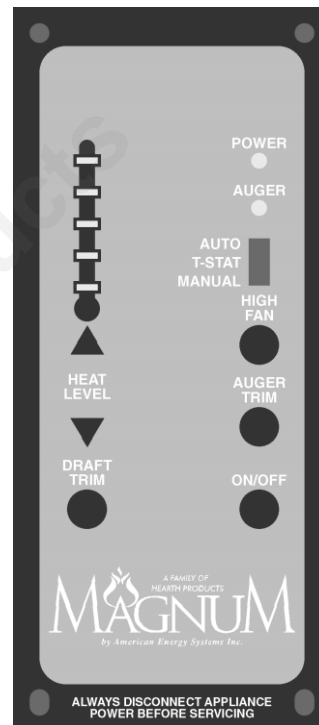

Your control panel comes with the ability to use ten (10) separate programming features. This programming must be done by a qualified factory trained technician. Contact your local dealer to set up an appointment to have this done. The unit also has three (3) separate modes of operation (switch located on top of board). The manual setting allows the operator to choose heat level setting changes. The T-STAT setting allows the operator to set the high heat level setting and when the thermostat is satisfied, the unit will automatically go to the low heat level setting. The AUTO setting allows the unit to shut completely off when the thermostat is satisfied and re-start when the thermostat calls for heat. This setting can only be used with Biomass Fuels.

## SETTING THE DRAFT

A proper draft setting is crucial to the successful burning of solid fuels. Draft refers to the amount of air flowing through the burn chamber/firebox of your unit. Too much or too little draft will cause your unit to burn improperly and may result in the fire burning out. Please follow these guidelines carefully as you operate your unit to achieve maximum efficiency and enjoyment.

- ✓ The amount of draft required for your unit to burn properly will depend upon your installation and the fuel you use. You can set your draft by looking at the flame and following these guidelines. The manual draft knob is the rod and knob on the left side of the unit or the handle on the back of the unit. Pulling the knob out increases the draft and pushing the knob in decreases the draft if the damper is on the back of the unit you trying it up will increase draft and turning to a 90 deg position will decrease. A little movement of the knob goes a long way to changing the flame. It may take several trial and error adjustments on the draft to achieve the correct setting.
- ✓ The flame should be an “active” flame. A flame that moves around lazily and emits visible smoke needs more draft. To give the fire more draft, pull the damper out 1/8” and check the flame again. If the status of the flame has not changed, move the damper another 1/8” until you get a clean “dancing” flame. **If moving the damper does not change the fire, you might have negative pressure in the home.**
- ✓ The base of the flame should be blue in color and the top of the flame should be white with some yellow.
- ✓ If the flame does not have enough draft, fuel will build up in the firepot and eventually smother the flame. If this happens, or if you notice the firepot is filling up with partially burned fuel, open the damper 1/8” at a time until the fire is clean and dancing. If this continues and moving the draft knob does not change anything, you probably have a negative air problem and should have a service tech inspect your installation. **Do not operate the unit if smoke is being pulled into the home.**
- ✓ If the flame has too much draft, the flame will look like a torch in that it will be moving rapidly and blowing fuel out of the firepot. If you find that you have this condition, move the damper inward 1/8” at a time until the condition of the flame changes.
- ✓ If the fuel crusts over, you will need to check into the fuel quality. This will also be a problem if you do not have outside air hooked up or if your home is starving for fresh air.

# AC MODEL WIRING DIAGRAM

WARNING: DISCONNECT POWER BEFORE SERVICING THIS UNIT.

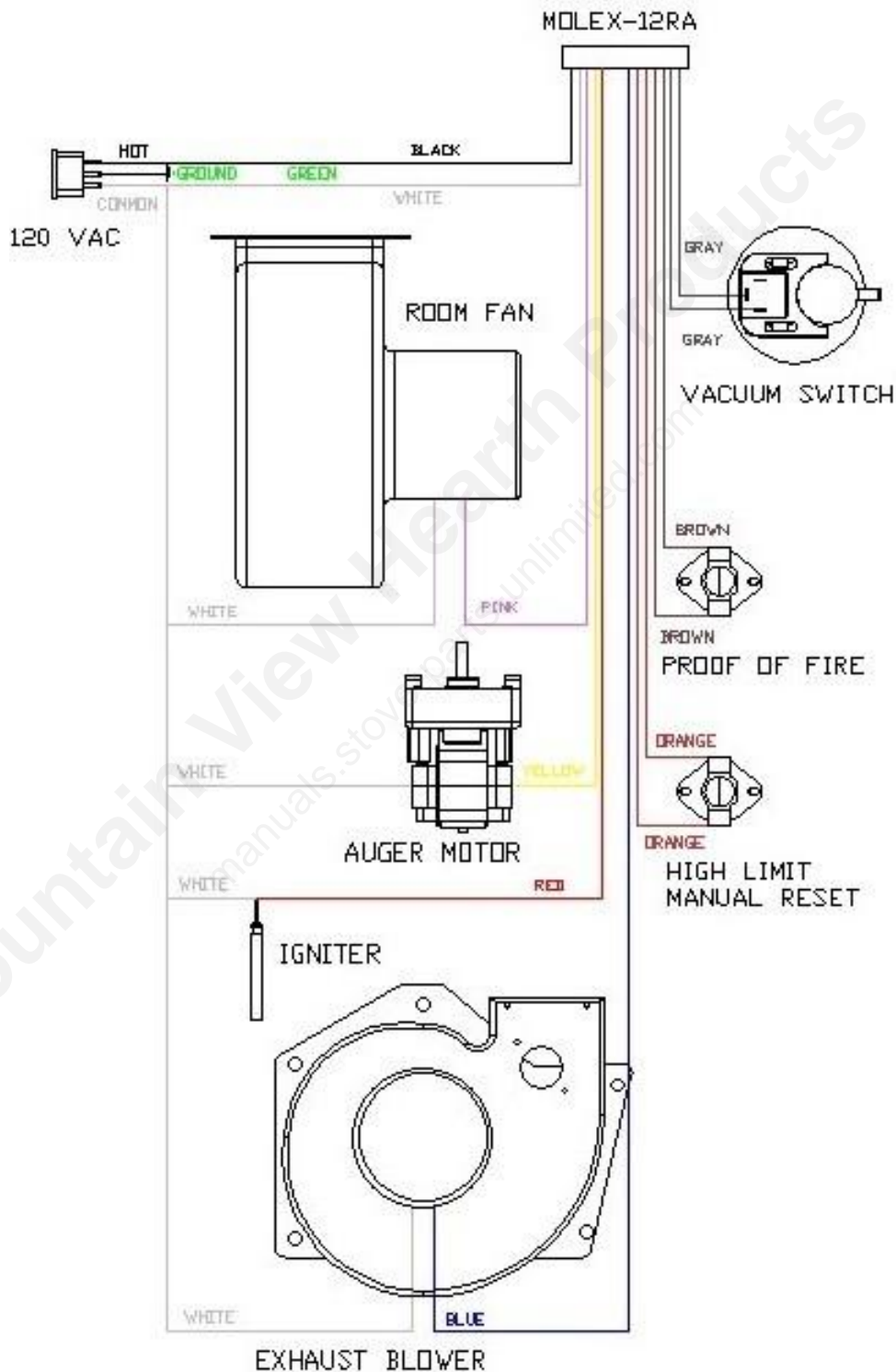

## IGNITER REPLACEMENT

The igniter system on the Magnum appliances' is an integral part of the wiring system. If the igniter is shorted out, the wiring must be disconnected in order for the unit to operate. If the wires are by-passed it will cause the stove to short out and blow a fuse. It is recommended that once a season the igniter is checked for proper operation and replaced if it does not glow red.

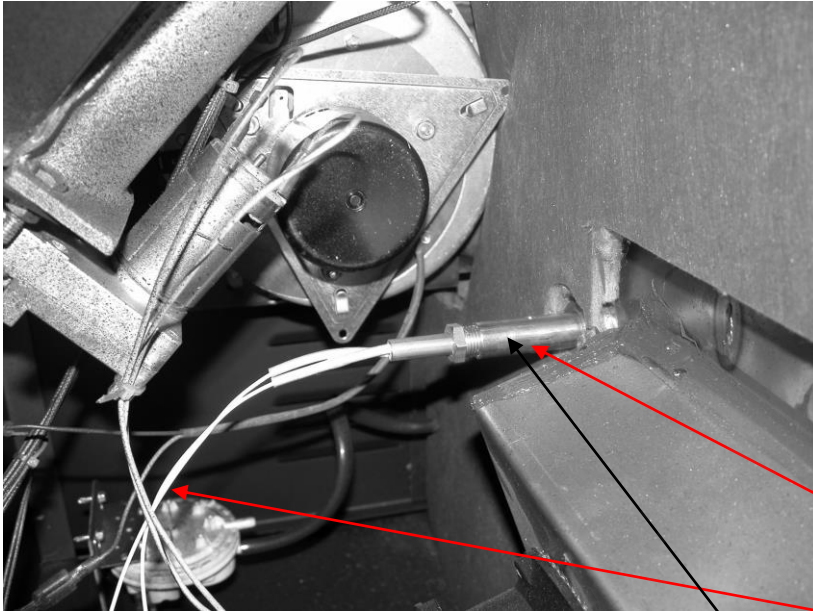

Access to the igniter assembly, can be made by opening the left side panel. The power must be disconnected, check that you do not pull on the wiring, when taking out the circuit board. Take special care not to cut yourself or damage wiring.

Use two (2) pliers or needle nose pliers to take the wire terminals apart. Be careful not to pull the wire out of the terminal ends as they are tight.

Ignitor

Wires for Igniter

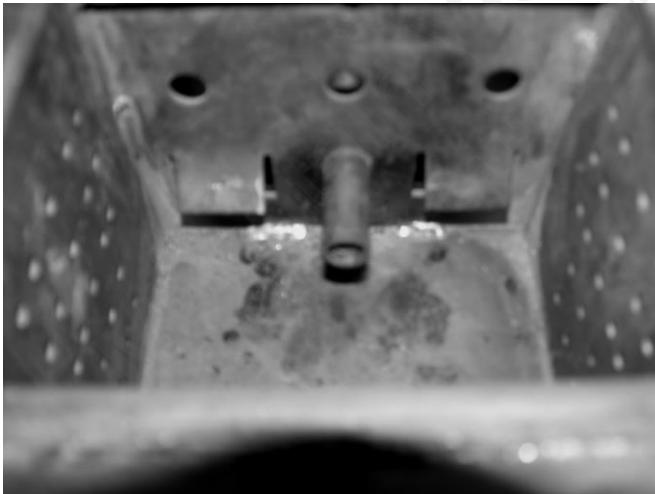

The igniter assembly is threaded, turn counter clockwise to loosen. You will be able to slide the igniter out the back if the end of the igniter in the firepot is not deformed. If the igniter will not slide out the back, you will need to work the igniter back and forth to dislodge any buildup.

Remove the firepot from the unit to access the igniter end. When installing the new igniter, hand tighten the igniter and then apply slight pressure to secure the threads. Do not over tighten the igniter assembly.

If you over tighten the igniter assembly it may ruin the igniter. Crimp and attach the terminal ends to the wiring harness. If you do not have a terminal crimping tool, you will need to get one from a hardware store. Igniters are a consumable item and will need to be replaced periodically.

**Do not attempt to take the igniter out of the unit while the unit is plugged into power or if the igniter is hot.**

# TROUBLE SHOOTING GUIDE

**Unplug power to the appliance before performing any service.**

PROBLEM	CAUSES	SOLUTIONS
<p><b>?</b> Fire burns with a lazy, orange flame and/or fuel builds up in the firepot and the glass will soot up quickly.</p>	<ul style="list-style-type: none"> <li>◆ Insufficient combustion air.</li> <li>◆ Feed rate too high for manual draft setting.</li> <li>◆ Fuel has too much moisture, has too many fines, too high of ash content or is old.</li> <li>◆ Combustion/Exhaust blower plugged or going out.</li> <li>◆ Venting plugged with fly ash or ice.</li> <li>◆ Home does not have adequate make up air (negative pressure).</li> <li>◆ Ash slides are pulled out.</li> </ul>	<ul style="list-style-type: none"> <li>✓ Remove any clinkers or ash from the firepot by using scraping tool. Clean entire system.</li> <li>✓ Clean out primary air in firepot holes if plugged.</li> <li>✓ Empty ash drawer. Clean out heat exchangers by removing the access plates.</li> <li>✓ Change to a better grade of fuel if necessary.</li> <li>✓ Check that damper control knob is adjusted properly. Pull out to increase fire burn.</li> <li>✓ Push ash cleanout slides in.</li> <li>✓ Check gasket seal around the door. If the door is loose, adjust the handle latch. A small adjustment can be made to the door seal by adjusting the door latch rod and/or the door hinges. Replace the door gasket if necessary.</li> <li>✓ Check for blockage in the air inlet tube or exhaust pipe. Clean out as needed.</li> <li>✓ Check combustion/exhaust blower impeller. This can be done by removing the exhaust pipe and shining a light into the tube or using the access plug on the exhaust manifold side plate.</li> <li>✓ Replace combustion/exhaust blower if needed.</li> </ul> <p><b>NOTE:</b> Negative pressure in a home is a serious issue. All MagnuM appliances should be installed with outside air hookups.</p> <p>Also, make sure that adequate ventilation is supplied for the rest of the home, or the unit will become the air intake causing problems.</p>

PROBLEM	CAUSES	SOLUTIONS
<p><b>?</b> Fire goes out or stove shuts down automatically.</p>	<ul style="list-style-type: none"> <li>◆ Hopper is empty.</li> <li>◆ Fuel is not feeding.</li> <li>◆ High limit temperature switch has tripped.</li> <li>◆ Vacuum pressure switch has tripped.</li> <li>◆ Poor quality or wet fuel.</li> <li>◆ Combustion air too high.</li> <li>◆ Fuel feed rate is too low.</li> </ul>	<ul style="list-style-type: none"> <li>✓ Refill hopper.</li> <li>✓ See “Fuel will not feed” below.</li> <li>✓ Allow stove to cool for 1 hour and relight after re-setting the high temperature thermodisk. If this problem persists, particularly at lower burn rates, then the high limit snap switch may need to be replaced contact your authorized Magnum reseller.</li> <li>✓ Correct cause of vacuum pressure switch tripping. Have an authorized tech service unit. Install outside air.</li> <li>✓ Replace fuel with proper fuel.</li> <li>✓ Adjust the damper to reduce combustion airflow.</li> <li>✓ Have your Magnum reseller adjust the fuel control.</li> </ul>
<p><b>?</b> <b>Fuel</b> will not feed.</p>	<ul style="list-style-type: none"> <li>◆ Hopper is empty.</li> <li>◆ Auger, circuit board, high limit switch tripped.</li> <li>◆ Foreign object caught in auger.</li> <li>◆ Fuel is dirty or wet.</li> <li>◆ Auger, circuit board, pressure switch or relay.</li> </ul>	<ul style="list-style-type: none"> <li>✓ Check contents of the hopper. Add fuel if necessary.</li> <li>✓ Check all operations, fuses, re-set manual high limit thermodisk.</li> <li>✓ Clean out auger system.</li> <li>✓ Have your Magnum reseller diagnose the problem and replace parts if needed.</li> </ul>
<p><b>?</b> Stove runs for 10 minutes and then shuts down.</p>	<ul style="list-style-type: none"> <li>◆ Exhaust gas is not up to temperature. Started on too low of heat level setting. Must be on # 3 heat level setting.</li> <li>◆ Low limit snap switch not operating correctly; may be defective.</li> <li>◆ Wires to either the low limit snap switch (mounted on the side of the firebox) are loose or disconnected.</li> </ul>	<ul style="list-style-type: none"> <li>✓ Relight the stove. Start on # 3 heat level setting.</li> <li>✓ Have your Magnum reseller replace the low limit switch.</li> <li>✓ Contact your Magnum reseller for service.</li> </ul>
<p><b>?</b> Blower will not shut off after the fuel has been switched off and the stove has cooled down.</p>	<ul style="list-style-type: none"> <li>◆ Low limit snap switch has failed in the closed position.</li> <li>◆ Unit has not cooled down yet.</li> </ul>	<ul style="list-style-type: none"> <li>✓ Have your Magnum reseller replace the low limit snap switch.</li> <li>✓ It can take up to 1 hour for the unit to cool down enough for the blower to shut off. If it takes longer than 2 hours for the blower to shut off or if it fails to shut off contact your local Magnum service technician.</li> </ul>

PROBLEM	CAUSES	SOLUTIONS
<p>? Room blower will not operate.</p>	<ul style="list-style-type: none"> <li>◆ No power to stove.</li> <li>◆ No power to control board.</li> <li>◆ Blower has overheated due to dirt on blades or in motor.</li> <li>◆ Blower is defective.</li> </ul>	<ul style="list-style-type: none"> <li>✓ Check to see that the unit is plugged into the wall outlet.</li> <li>✓ Check to see if your circuit breaker has “tripped”.</li> <li>✓ Clean blades and motor, have a Magnum tech replace blower if needed.</li> </ul>
<p>? Soot or fly ash in the house.</p>	<ul style="list-style-type: none"> <li>◆ Cleaning the glass, particularly when the unit is operating.</li> <li>◆ Leakage on the joints between the combustion fan, exhaust pipe and “PL” vent. This will be evident by dust on the heat exchanger tubes and the impeller of the room fan.</li> <li>◆ Using a conventional vacuum for cleaning. Ash will bypass the filter and enter the room.</li> <li>◆ Negative pressure in home sucking ash/soot out of venting and unit.</li> <li>◆ <b>Fireplace insert installation:</b> If the existing fireplace opening was not thoroughly cleaned and painted before the insert was installed, then the room fan may be picking up the fireplace dust, soot or ash and blowing it into the home.</li> </ul>	<ul style="list-style-type: none"> <li>✓ Clean the glass when the unit is not running.</li> <li>✓ Seal any leaks in the exhaust system with RTV high temperature silicone sealer.</li> <li>✓ Use approved ash vacuum.</li> <li>✓ Correct negative pressure situation.</li> <li>✓ Pull the insert away from the fireplace opening. Thoroughly clean the opening and paint the inside of the opening with latex or an inexpensive spray paint to hold the finer particles of dust.</li> </ul>
<p>? Buildup of soot on glass, venting and heat exchangers.</p>	<ul style="list-style-type: none"> <li>◆ Dirty fuel.</li> <li>◆ Inadequate air supply.</li> <li>◆ Negative pressure in home.</li> <li>◆ Air wash plugged or out of adjustment.</li> </ul>	<ul style="list-style-type: none"> <li>✓ Make sure you use clean fuel.</li> <li>✓ Pull manual draft control out slightly to insure there is app. 1/2” of fuel in firepot.</li> <li>✓ Install outside air to unit. Verify home has adequate make-up air. (Suggested 6” make-up air into home.)</li> <li>✓ Clean air-wash located on bottom of glass door.</li> </ul>

**CAUTION:** When performing any internal electrical maintenance

- Moving parts inside of the cabinet may cause injury.
- HOT parts. Do not operate the unit with panel open.
- Risk of electrical shock. Disconnect power before servicing unit.
- In the event of component failure, replace with original factory equipment.

**IMPORTANT:** Electrical work must be performed by a Factory authorized technician.

PROBLEM	CAUSES	SOLUTIONS
<p><b>?</b> Fuel burns off to quickly, have difficulty keeping a pilot fire.</p>	<ul style="list-style-type: none"> <li>◆ Air shutter is open to far.</li> <li>◆ Over drafting on a vertical install.</li> <li>◆ Outside air is not hooked up.</li> <li>◆ Positive or negative pressure in home is affecting the units operation.</li> </ul>	<ul style="list-style-type: none"> <li>✓ Adjust your air damper to a more closed position.</li> <li>✓ A chimney restrictor may need to be installed. Consult with your MagnuM dealer.</li> <li>✓ Make sure that the installation is correct and nothing is affecting the furnace room.</li> </ul>
<p><b>?</b> Foreign object caught in the auger and will not turn.</p>	<ul style="list-style-type: none"> <li>◆ Accidental object in fuel.</li> </ul>	<ul style="list-style-type: none"> <li>✓ If there still is a fire, let it extinguish and let the unit cool down. Unplug unit after the fire has exhausted. It will be necessary to clean out hopper. As you are facing the unit open the right side panel.</li> <li>✓ Take the auger motor off and gently turn the auger backwards until the object is free.</li> <li>✓ If you cannot get the object loose, contact your MagnuM Reseller.</li> </ul>
<p><b>?</b> Getting to much ash.</p>	<ul style="list-style-type: none"> <li>◆ Dirty fuel.</li> <li>◆ Wet fuel.</li> <li>◆ Lack of clean combustion air.</li> <li>◆ Dirty or plugged stove or venting. Poor exhaust vent configuration.</li> <li>◆ Negative pressure present in the home.</li> <li>◆ Exhaust fan motor going out.</li> <li>◆ Use combustion enhancement system.</li> </ul>	<ul style="list-style-type: none"> <li>✓ Dirty, wet fuel will produce excessive ash.</li> <li>✓ Obtain quality fuel.</li> <li>✓ Take proper steps to protect fuel from the elements to not take on moisture.</li> <li>✓ Check air damper and check combustion air inlet for obstructions.</li> <li>✓ Check all cleanouts and exhaust venting for obstructions. Refer to cleaning section of this manual.</li> <li>✓ Call your MagnuM reseller to inspect the installation, operation and replace any bad parts if necessary.</li> </ul>
<p><b>?</b> The heat output is not as high as when the unit was installed.</p>	<ul style="list-style-type: none"> <li>◆ Wet or dirty fuel.</li> <li>◆ Inadequate cleaning.</li> <li>◆ Change of fuel to lower BTU value.</li> <li>◆ Negative pressure or improper fresh air make up system.</li> </ul>	<ul style="list-style-type: none"> <li>✓ Wet fuel has a much lower BTU output. Dirty fuel does not produce adequate heat. Excessive amounts of fines interrupt the amount of fuel delivered for burning and will decrease heat output.</li> <li>✓ Clean heat exchangers daily, inspect unit for proper air flow.</li> <li>✓ Have your MagnuM dealer check for proper installation and negative pressure in the home.</li> </ul>

AMERICAN ENERGY SYSTEMS, INC. - Order placement: E-Mail: office@magnumheat.com

For orders Fax 320-288-7224 or call (800) 495-3196. For Technical Support Call (320) 227-2902 or email

**MAGNUM BABY COUNTRYSIDE, T40, ESSEX, AVENT REPLACEMENT PARTS PRICE LIST**

ORDER #	MODEL NAME/DESCRIPTION	MSRP
AV07	Door, Black, Avent (Complete Door Assembly) for replacement	
BC2076	Door, Gold, Baby Countryside (complete door assembly)	
BC2077	Door, Black, Baby Countryside (complete door assembly)	
BC2079	Door, Brushed Nickel, Baby Countryside (complete door assembly)	
BC2650	Firepot, Cast Iron, Wood Pellet, Baby Countryside, Winchester	
BC2700	Firepot, Stainless Steel, Corn, Baby Countryside, Winchester	
BC3600	Panel, Top Lid, Baby Countryside, complete & painted	
BC5019	Panel, Right Side, BC-AC & DC models, complete & painted	
BC5020	Panel, Left Side, BC- AC & DC models, complete & painted	
BC5025	Ash Pan Weldment, Baby Countryside	
MF3532	Cord, Power (All AC Models)	
MF3537	Safety Sensor, Low limit / Fan - 110 deg.	
MF3541	Room Blower, AC T40, Baby Countryside, (Not for T40ACI)	
MF3598	Queen Ann Leg, 24K Gold (per leg)	
MF3598-4	Queen Ann Leg, 24K Gold (set of 4)	
MF3599	Queen Ann Leg, Bright Nickel (per leg)	
MF3599-4	Queen Ann Leg, Bright Nickel (set of 4)	
MF3600	Queen Ann Leg, Black (per leg)	
MF3600-4	Queen Ann Leg, Black (set of 4)	
MF3626	Door Handle Assembly, Baby Countryside, Winchester (replaces RP2097)	
P1128	Gasket, Exhaust Blower, DC (By Manifold)	
P1135	Gasket, Exhaust Blower, DC (Between Motor and Fan)	
P1155	Handle, Heat Exchanger Rake, T40 & Essex	
P1163	Fuel Spreader Bracket, (for WIN-ACP & WIN-ACI units) (Older Units)	
P1178	Bushing, Delron, Magnum Winchester/Baby Countryside	
P1179	Bushing, Bronze, Winchester, Baby, (upper auger bushing)	
P1315	Blade, Draft Blower, DC 4 3/4" diameter (located in draft blower housing)	
P1316	Blade, Combustion/Draft Blower, DC, 3" Diameter (replacement blade)	
P5028	Auger Housing Back Plate, Baby Countryside, Domestic	
P5028C	Auger Housing Back Plate, Baby Countryside, Global	
P5063	Igniter Tube, Baby Countryside & Winchester (Tube Only)	
P7670	Hopper Lid Plastic handle	
P8090	Auger Mount Bracket, NEW, BC & WIN models	
P8092	Auger Drop Tube Fuel Spreader, Winchester	
P003011	Latch, Spring Door W/Black knob (Use on Ash Pan Door)	
P003098	Auger Shaft Collar, Magnum Baby Countryside, 5/8 ID	
RP2000	Igniter, T40, Essex (not used in Baby Countryside models)	
RP2001	Brick Panel, Left, T40, Essex, T40-I Insert, (not for Winchester models)	
RP2002	Brick Panel, Right, T40, Essex, T40-I Insert, (not for Winchester models)	
RP2007	Control Board, AC, Baby Countryside, T40 (digital, 3 programs)	
RP2009	Igniter, Replacement, Baby Countryside & Winchester	
RP2011	Power Supply, DC, Baby Countryside, Winchester, Essex & T40, New version 11/06 (can be retrofitted to older models)	
RP2015	Control Board, DC, Super Board, Baby Countryside & T40, Essex	
RP2016	Control Board, AC, Magnum, (NPS-1005-N Programmed for Winchester)	
RP2020	Auger Motor, DC, 2rpm, Baby Countryside, T40, Essex, Avent	
RP2022	Auger Motor, AC, 2rpm, Baby Countryside, T40, Essex	
RP2025	Motor, Combustion/draft, DC, Baby Countryside, T40, Essex (Motor Only)	
RP2026	Plate, Motor Support, Combustion/Draft, DC, Baby Countryside, T40, Essex	
RP2027	Blower, Combustion/Draft, Complete, DC, Baby Countryside, T40, Essex	
RP2030	Blower, Exhaust, T40AC, Baby Countryside AC, Essex AC (2-speed)	

RP2035	Room Fan, <b>DC</b> , T40, Baby Countryside, T40, Essex, Avent (6 » round)		
RP2036	Room Fan, <b>DC</b> , Baby Countryside, T40, Essex, Avent DC (new style)		
RP2040	Room Blower, AC, T40ACI		
RP2050	Switch, L-225 N/C T40, Baby Countryside, Essex (Manual Reset)		
RP2062	Wire Harness Assembly, DC, Baby Countryside, T40, Essex		
RP2063	Wire Harness Assembly, AC, Baby Countryside		
RP2083-OLD	Firepot, T40, Essex (Cast Iron Firepot, old style) 2006 & earlier IGNITER HOLE ½” UP FROM INSIDE BOTTOM OF FIREPOT		
RP2083	Firepot, T40, Essex (Cast Iron Firepot, New style) 2006 & newer IGNITER HOLE FLUSH WITH INSIDE BOTTOM OF FIREPOT		
RP2087	Trivet, Black, Baby Countryside, (purchased separate from unit)		
RP2090-P400	Auger Flighting Assembly, Baby Countryside & Winchester		
RP2091	Bushing (set), Auger, Baby Countryside, T40, Essex, Avent Includes P1178 & P1179 bushings (Lower and Upper)		
RP2093	Handle, Damper Spring		
RP2094	Plug, Clean out, 2”, Steel, Winchester, Essex, T40		
RP2096	Hose, ¼”, Neoprene (per foot)		
RP2097	Door Handle Assembly, T40 & Baby Countryside (use part MF3626)		
RP2098	Glass, Arched, Baby Countryside, T40 Essex		
RP2100	Gasket, Door (per foot) ¾” dia. Black, (use part number PP-87)		
RP2120	Control Board, Faceplate, Replacement for Bergquist AC & DC Digital		
RPT2805	Wiring Harness, with Power Supply, Avent		
RT080	Switch, Vacuum Pressure, Baby Countryside, T40, Essex, (was RP2055)		
RT080-B	Bracket, Mounting RT080		
R0117	Knock Out Plug, 2” Round		
R0122	Gasket, Room Air Blower (all Magnum & Country flame models)		
R0125	Spring Latch, Small, Slotted, Baby Countryside (holds side panel shut)		
R0080	Gasket, Door Seal ½” Graphite, Baby Countryside, T40, Hopper		
R0092	Gasket, Door, Ash Pan 1/16” x ½” gasket tape		
R-131	Gasket, Door (per foot) 5/16”		
R-133	Gasket, glass channel, 3/8” rope		
P2222	Glass, Avent		
WIN-4000	Brick Panel, Left ( for Winchester Pedestal , not for WIN-I Insert use WIN-4005-L)		
WIN-4001	Brick Panel, Right ( for Winchester Pedestal , not for WIN-I Insert use WIN-4006-R)		
WIN-4005-L	Brick Board, WIN-ACI, Left panel		
WIN-4006-R	Brick Board, WIN-ACI, Right panel		
<b>Parts not used in current models</b>			
RP2004DC3	Control Board, <b>DC</b> , Baby Countryside, T40, Essex (digital, 3prog.)		
RP2006	Control Board, <b>AC</b> , T40 (Digital electronic board, old style)		
RP2010	Power Supply, <b>DC</b> , Baby Countryside, T40, Essex (RPS-300) (Old version)		

## AMERICAN ENERGY SYSTEMS INC. LIMITED PRODUCT WARRANTY

**This warranty is in effect on all products sold after 01/01/2009 and supersedes any and all warranties currently in existence.**

***Please keep a copy of this warranty for your personal records or in the event of a claim***

American Energy Systems Inc., hereinafter referred to as (AES), warrants to you, the original consumer purchaser, that this product is free from defects in material and workmanship for a period of five (5) years from the original purchase date minus any time past one (1) year from manufacturing date, and that the product's electrical parts and steel firepot, are free from defects in material and workmanship for a period of one (1) year from the original consumer purchase date minus any time past one (1) year from manufacturing date, and that the cast iron firepot models carry a lifetime warranty against defect in material or workmanship (excluding war page or deterioration), and that door glass carries a lifetime replacement warranty against heat breakage (does not cover accidental breakage). There is expressly no warranty on installation of product, any venting, grates, gaskets, door latches, insulation, ceramic or brick boards/logs/backing, paint, plated surfaces/doors/trims, baffles, bushings, bearings, auger lightings, war page or discoloration of steel or plated parts or any other normal wearing part. In the event the product fails to conform to this warranty, AES, through the place where you purchased the product or if purchased on the AES E-Com store directly through AES, will provide the parts and components necessary to remedy such nonconformity. **AES will not be responsible for any labor, mileage or freight cost to and from the factory under this warranty.** This warranty is not transferable.

In order to obtain performance under this warranty, you must (1) have registered this warranty within 30 days of purchase by completing and returning the warranty registration card or filling in the on-line warranty registration form at [www.magnumheat.com](http://www.magnumheat.com), and (2) promptly report the claimed nonconformity to your place of purchase, also providing your name, address, phone number, proof of purchase, date of purchase, the model and serial number of the stove, digital pictures of installation and venting inside and outside of the home, pictures of the claimed nonconformity part and the claimed nonconformity. **All claims must be submitted in writing to your place of purchase.**

AES shall have no warranty obligations if this product; (1) was not purchased from an authorized AES product reseller; (2) was not installed by a AES qualified installer/service provider; **does not have outside combustion air hooked directly to the unit**; (3) was not operated and maintained in strict accordance with the manufacturer's instructions, local or national codes or (4) was subject to abuse, misuse, negligence or accident. AES shall have no warranty obligation for damage caused by improper handling, freight damage (must be reported to freight provider), over-firing, unapproved fuel, variance in feed rates, variances in BTU output or the unauthorized disassembly or modification of the product. AES shall have no warranty obligation if this warranty is not timely registered, for claims which are not submitted through the selling AES dealer, or for claims submitted verbally or without the required information and documentation.

Before exercising this warranty, an AES representative (the place where the product was purchased or AES approved person) must inspect the part/unit to determine if the part/unit is defective. If a local AES representative is not available the original purchaser of the product must submit digital pictures of the part/unit, installation of the unit to AES at [technical@magnumheat.com](mailto:technical@magnumheat.com). If the inspection reveals that the failure is due to defective material or workmanship and the part is covered by the conditions of this warranty, AES will, at its option, repair the defective part/unit. The sole duty of AES and liability under this warranty is limited to the repair of the covered defective part/unit. The purchaser shall assume all costs related to shipping the replacement parts or return of the unit to and from the factory for repairs. If it is determined that the defect was caused by AES, AES will cover the costs of shipping the repaired part/unit to an AES approved shipping point. AES will not cover additional freight or delivery services such as residence delivery charges, special handling, etc.

### **INSTALLATION, VENTING, REMOVAL OR REINSTALLATION COSTS ARE NOT COVERED BY THIS WARRANTY.**

THE WARRANTY PRINTED ABOVE IS THE ONLY WARRANTY APPLICABLE TO THE PRODUCT. ALL OTHER WARRANTIES, EXPRESSED OR IMPLIED, INCLUDING, WITHOUT LIMITATION, THE IMPLIED WARRANTIES OF MERCHANTABILITY AND FITNESS FOR A PARTICULAR PURPOSE, ARE DISCLAIMED. IT IS UNDERSTOOD AND AGREED THAT AES'S LIABILITY UNDER THIS WARRANTY SHALL BE LIMITED TO THE PROVISION OF REPLACEMENT PARTS AND SHALL NOT INCLUDE LIABILITY FOR SPECIAL, INCIDENTAL OR CONSEQUENTIAL DAMAGES. ANY ACTION BROUGHT UNDER THIS WARRANTY MUST BE BROUGHT WITHIN ONE YEAR OF THE ACCRUAL OF THE CAUSE OF ACTION AND MAY ONLY BE BROUGHT IN THE CIRCUIT COURT OF MCCLLOUD COUNTY, MINNESOTA.

Some states do not allow limitations on how long an implied warranty lasts or the exclusion or limitation of incidental or consequential damage, so the above limitations may not apply to you. This warranty gives you specific legal rights, and you may also have other rights which vary from state to state.

ALL WARRANTY CLAIMS MUST BE SUBMITTED IN WRITING THROUGH THE PLACE WHERE THE PRODUCT WAS PURCHASED. In the event where the place of purchase has ceased business or if you feel that there is a legitimate reason that you cannot submit your claim to the place where the product was purchased you may make a written request to the factory by emailing your request along with all of the required information to [technical@magnumheat.com](mailto:technical@magnumheat.com). **NOTE: Verbal requests will not be recognized. If it is determined that warranty could have been performed by the place of purchase, the factory will deny the claim.**

Included with the claim must be the following information: (if this information is not complete, the claim will be denied)

Name, address, telephone number, email address, of place of business where product was purchased & also purchaser contact info.

Date of purchase, model and serial number of product, digital pictures of product (front, sides, back, venting inside and outside)

(If there is ductwork, there must be digital pictures of entire ductwork installation, static pressures, air flow measurements, and contact information of licensed/factory certified contractor that installed unit)

Nature of defect, what has been serviced (service record), who installed product along with contact information.

