

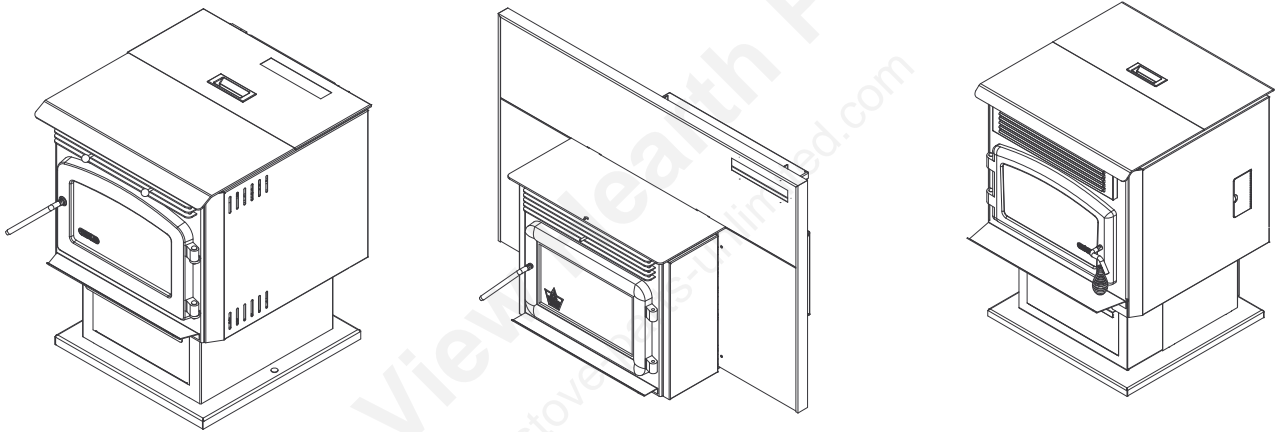

## General Error Code Instructions



Model:

**Series 35 pellet stove and insert, and  
Series 45 pellet stove**

# Table of contents

This guide was designed for specialized technicians and technical representatives to help identify problems and find solutions for the correct operation of our pellet stoves.

35 series pellet stove and insert drawings .....	3
35 series pellet stove and insert electrical diagram.....	4
45 series pellet stove drawings .....	5
45 series pellet stove electrical diagram .....	6
Display function.....	7
Maintenance .....	8
Recommended maintenance schedule .....	8
Installation.....	9
Error codes .....	10
Error correction procedures .....	11
Resetting the control board.....	12
Error code « P ».....	13
Error code H.....	16
L250 Automatic Sensor Identification.....	17
Error code « H1 ».....	18
Error code « H2 ».....	20
Error codes « H3 » and « H4 » .....	22
Error code « O ».....	24
Error code « E ».....	26
Error code « L » .....	29
Error code « d » .....	32
Error code « n » .....	34
Error code « C ».....	35
Error code « I » .....	35
Testing procedure for series 35 pellet stove and insert:.....	37
Thermistor temperature reading for 35 series .....	41
Testing procedure for series 45 pellet stove: .....	42
Thermistor temperature reading for 45 series .....	47

## 35 series pellet stove and insert drawings

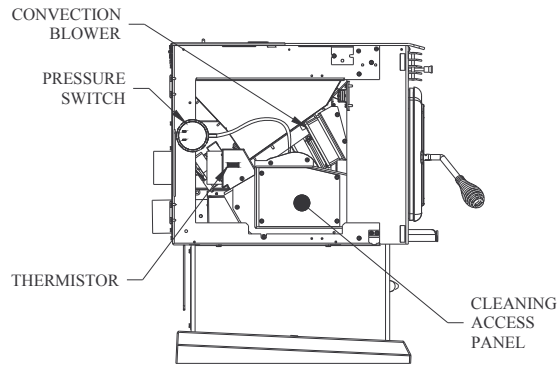

Left side

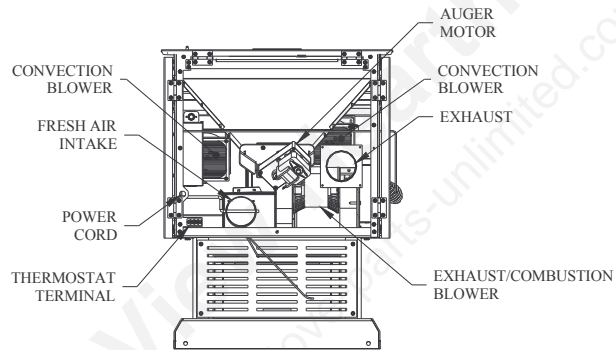

Back

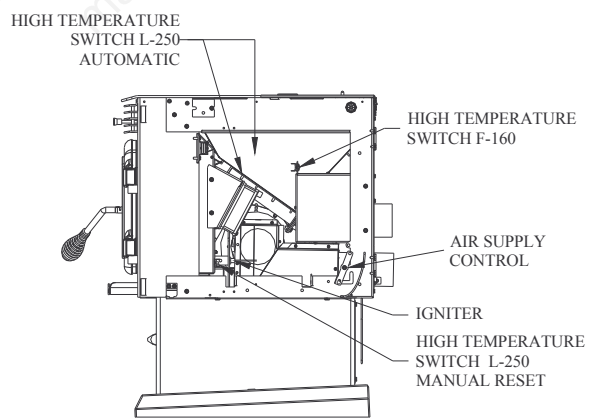

Right side

# 35 series pellet stove and insert electrical diagram

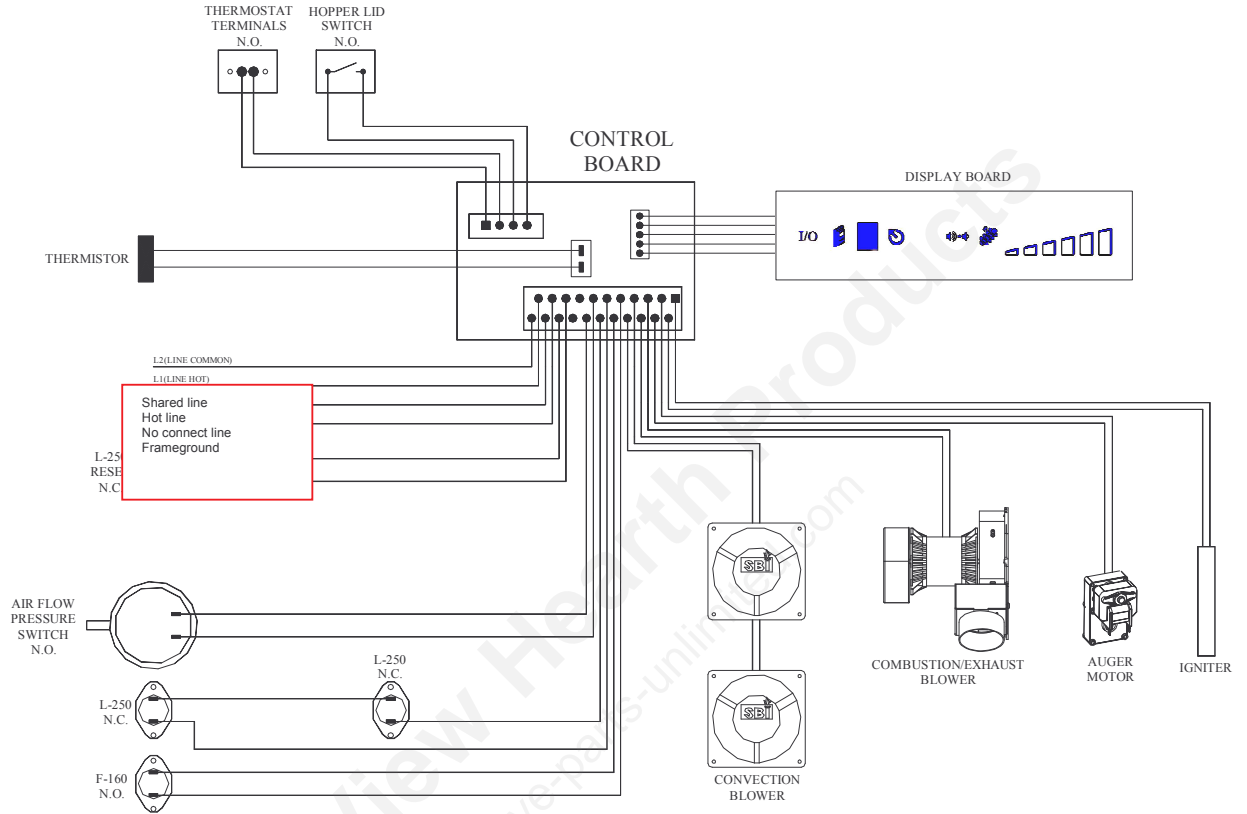

## 45 series pellet stove drawings

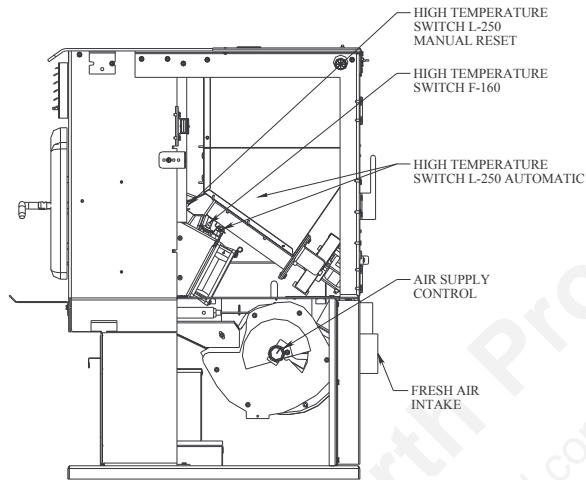

Right side

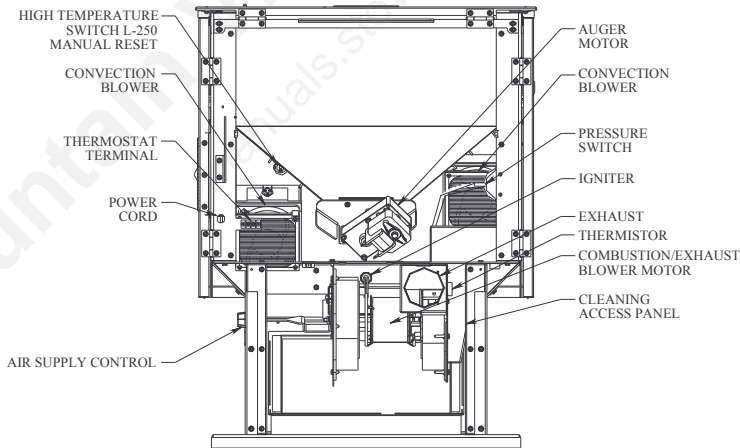

Back

# 45 series pellet stove electrical diagram

With F-140 sensor

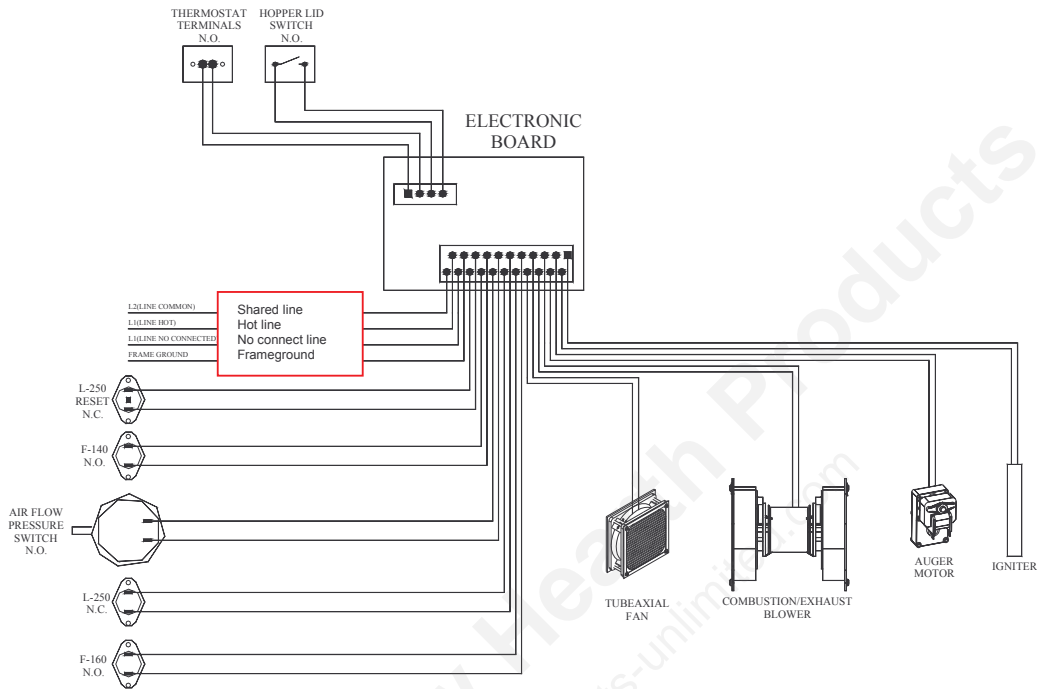

With Thermistor

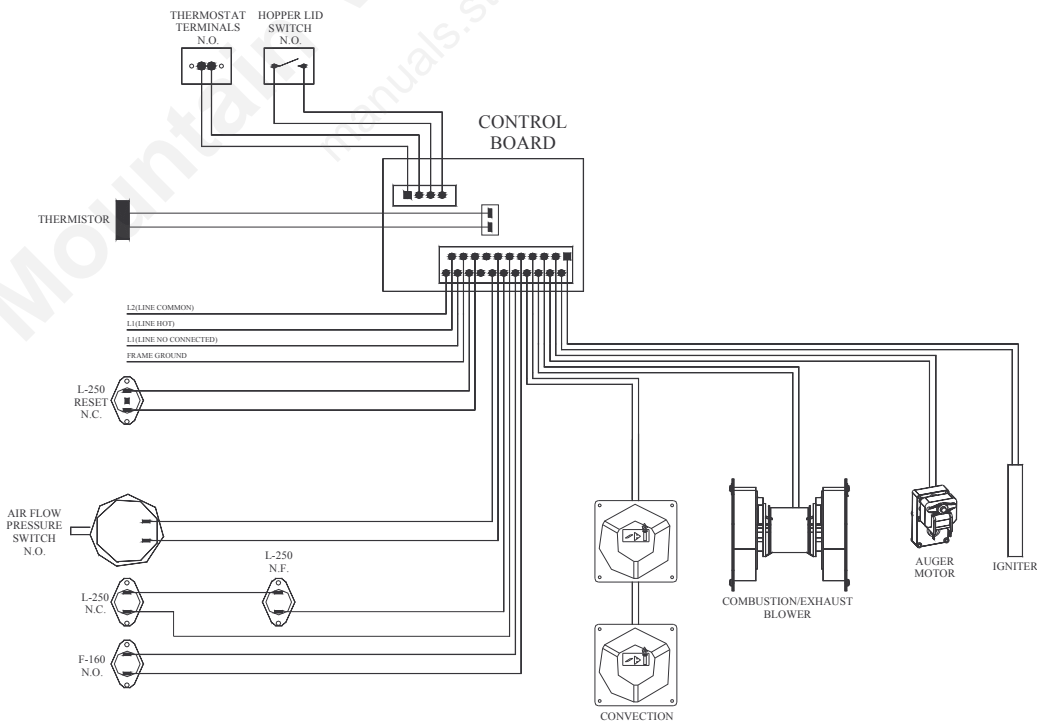

## Display function

### 35 series pellet stove and insert display

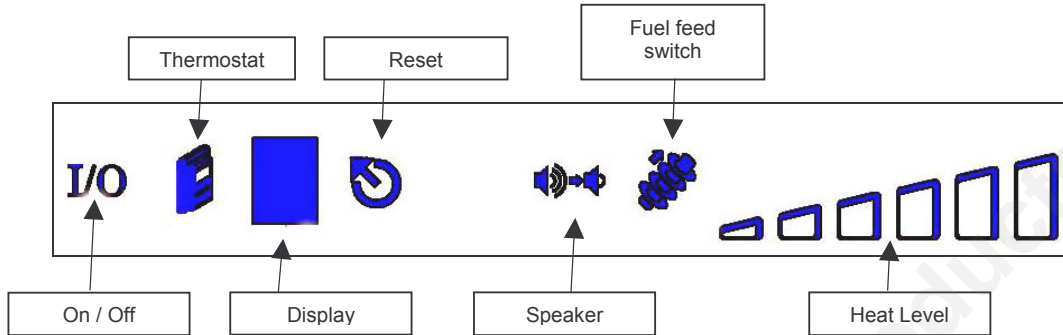

### 45 series pellet stove display

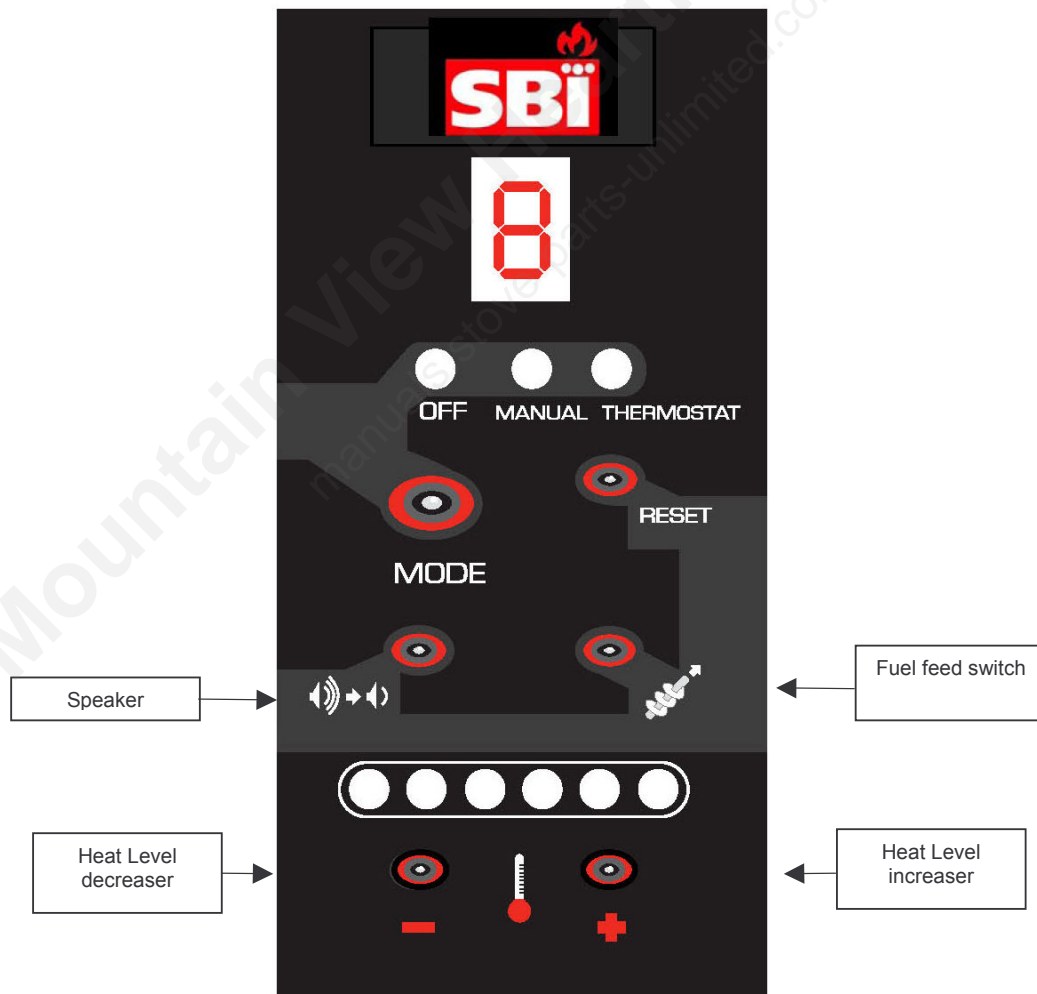

## Maintenance

Cleaning and maintaining your pellet stove will help keep it operating properly and prevent fire or smoke damage. Poor maintenance increases the risk of overheating and triggers error codes.

For instructions and technical information on how to clean your pellet stove, refer to the maintenance and cleaning procedures sections of the owner's manual.

We recommend you follow a routine maintenance schedule as shown in the table below.

### Recommended maintenance schedule

Use this as a guide under average-use conditions.

Component	Daily	Weekly/as needed + or 10 bags *	Bi-annually + or 25 bags *	Annually or per ton of wood pellets burnt *
Burn Pot	Stir	Empty/brush		
Glass	Wipe	Clean		
Combustion Chamber		Vacuum	Brush	
Ashes		Empty		
Interior Chambers		Vacuum		
Heat Exchange Tubes		Clean (with rod)		
Baffle		Empty and clean		
Combustion/Exhaust Blower Blades & Pressure Switch Probe			Vacuum/Brush	
Convection Blower Blades		Vacuum		
Vent System				Clean/brush
Gaskets			Inspect	
Hopper (end of season)				Empty and vacuum

\* whichever comes first

The gasket around the door and door glass should be inspected and repaired or replaced when necessary (see "REPLACEMENT PARTS").

We recommend cleaning the stove and the exhaust pipes when you receive error codes H, P, L or O.

## Installation

In order to identify the problem quickly, always start by checking the installation.

Refer to the owner's manual for all questions concerning pellet stove installation standards.

### Equivalent vent length (EVL)

A longer run of vertical pipe will decrease the restriction in the exhaust system.

- Use 4" pipe if you have more than 15 feet of Equivalent Vent Length (EVL).
- Horizontal runs shall not exceed 10 feet of EVL.

To calculate EVL, use the following conversion table :

Qty	Type of pipe	Equivalent Vent Length (EVL)
1	90° elbow or "T"	5 feet
1	45° elbow	3 feet
1 ft	Horizontal pipe run	1 foot
1 ft	Vertical pipe run	0.5 foot

NOTE: At altitudes above 3,000 feet, we suggest the use of 4" diameter vent for EVLs of 7 feet or more.

Here is an example of how to calculate the EVL of your installation.

(3 x 4' of vertical length = 12' x 0.5 = 6 EVL) + (1 x 90° elbow or "T" = 5 EVL) + (2 x 1' of horizontal length = 2 EVL)

Total EVL = (6 + 5 + 2) = 13. So a 3" diameter vent is acceptable.

## Error codes

When you see an error code on your stove display, your first reaction may be to call for assistance.

This guide may save you time and money by helping you resolve simple problems yourself. Problems can be caused by:

- 1) Poor quality fuel
- 2) Poor maintenance
- 3) Improper installation
- 4) Component failure

Refer to the ELECTRICAL DIAGRAM section to help identify and locate stove parts.

ERROR CODES	
MESSAGE	CORRESPONDING ERROR
P	Pressure switch error.
H	Error caused by one of the two automatic L-250 sensors: one is located under the pellet chute and the other one is inside the hopper heat shield .
O	L-250 manual reset high temperature switch, located beside convection blower.
E	Hopper is empty.
L	Ignition error.
d	Hopper lid stayed open for more than 3 minutes.
n	Inverted polarity in power outlet (will not prevent the stove from operating).
C	Power outage.
!	Igniter fuse is burnt out.

## **Error correction procedures**

This document will help you identify and troubleshoot all of the error codes that will appear on the board display if a problem occurs.

### **Procedure to clean pellet stove**

- Empty and clean the burn pot.
- Clean the combustion chamber.
- Empty the ashes from the stove.
- Clean the inside wall of the combustion chamber.
- Clean behind the inside wall of the combustion chamber (by the exhaust side trap)
- With the door closed, clean the heat exchanger tubes by inserting and withdrawing the cleaning rod several times.
- Remove the baffle and scrape off the ashes.
- Clean the convection blower impeller and protective filter.
- Clean the Combex blower and impeller.
- Clean the pressure switch probe connector.



### **Verification of the exhaust (chimney) draft**

- Open the left panel of the stove.
- Disconnect the pressure switch sensor tube and connect it to a draft gauge.
- Take the same measurement again with the stove disconnected from the chimney.
- The measurements should be approximately the same.
- If there is a difference, there may be an obstruction in the chimney or the evacuation system may be too restrictive.





## Resetting the control board

After an error code appears on the display board, you can reset the control board as follows:

### 1. Reset procedure for control board error code









- Series 35 stove and insert: press  and restart the stove
- Series 45 stove: press  and restart the stove

### 2. Reset procedure for H code error only

- Series 35 stove and insert: Hold down the  and  buttons simultaneously for approximately 3 seconds
- Series 45 stove: Hold down the  and  buttons simultaneously for approximately 3 seconds

### 3. Reboot procedure for H code error only

If the stove was reset 3 times for a H code error, the card will be lock and you will need a different reset procedure :

- 35 series stove and insert: press  +  + 6<sup>th</sup> speed + 1<sup>st</sup> speed in succession and then hold down  for approximately 3 seconds
- 45 series stove: press  +  +  +  in succession and then hold down  for approximately 3 seconds

Follow the logical sequence described in this guide to examine every possible cause of the problem and correct the error code.

### Error code « P »



This error code occurs mainly when pipe is blocked

STOVE SHUTS OFF OR DOES NOT START AND DISPLAYS ERROR CODE "P"		
<b>Possible Causes:</b>	<b>Possible Solutions:</b> (Unplug stove first if possible)	
1. Airflow pressure switch hose or hose connector tip is blocked.	Pull the air hose out of the airflow switch and blow through it. If air flows freely, the hose and tube are fine. If air will not flow through the hose, use a thin wire to clear the blockage. If the problem occurs again soon, you may have to remove accumulation on the pressure switch probe located inside the exhaust blower housing (refer to the maintenance section).	
2. The air inlet, burn pot, interior combustion air chambers, combustion blower, or exhaust pipe is blocked with ash or foreign material.	Follow all cleaning procedures in the maintenance section of the owner's manual.	
3. Vent pipe is incorrectly installed.	Check to make sure vent pipe installation meets the criteria in the owner's manual as well as the pipe manufacturer's recommendations.	
4. The pressure switch connections are faulty.	Check the connectors attached to the pressure switch.	
5. The pressure switch wires are pulled loose from the connectors on the wiring harness.	Check to see whether the wires are loose at the connectors.	
6. Combustion/exhaust blower failure.	This blower must turn on when you start the unit. If it does not, make sure there is power on the connections. If the power is connected, the motor is probably defective; if there is no power, see #7.	
7. Control board is not sending power to the combustion/exhaust blower.	If there is no power going to the combustion blower, check all connections. If all wires are properly connected, you have a defective control board.	
8. Control board is not sending power to the pressure switch.	There should be 120-volts going through the pressure switch when the stove is on. You will need a technician to perform this test.	
9. Airflow pressure switch has failed (very rare).	To test the airflow pressure switch, you need to disconnect the air hose from the blower casing. With the other end still attached to the switch, very gently suck on the loose end of the hose (you may want to completely disconnect the hose from the stove and the switch first and make sure it is clear). If you hear a click, the switch is working. BE CAREFUL: TOO MUCH SUCTION CAN DAMAGE THE SWITCH.	

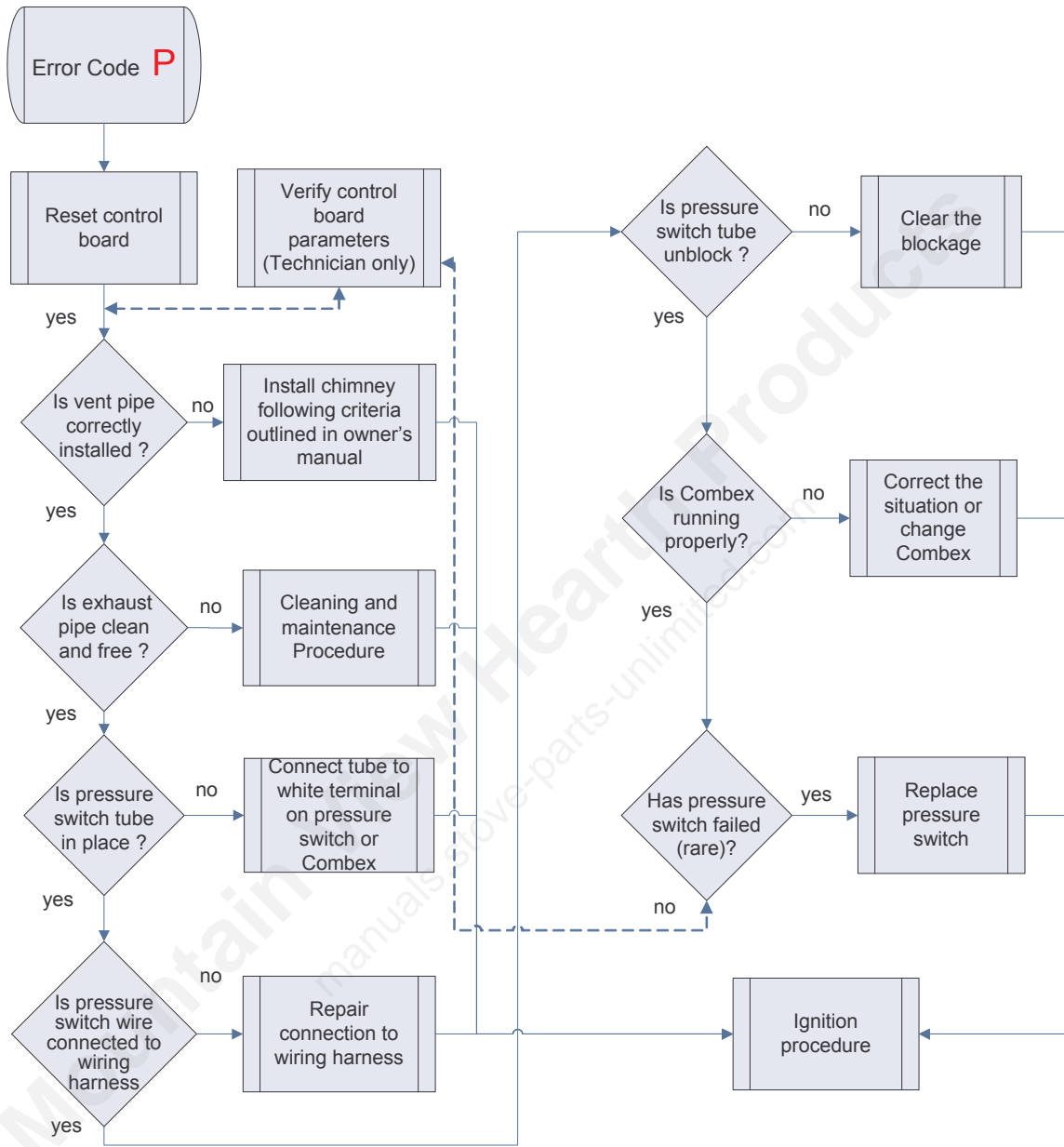
## Resolving P (flow chart)



### Reset procedure for control board error code

- Series 35 stove and insert: push  and restart the stove
- Series 45 stove: push  and restart the stove

## PRESSURE SWITCH

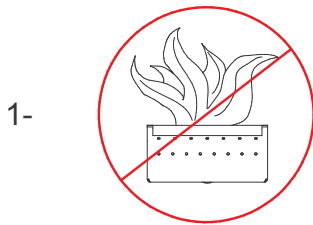
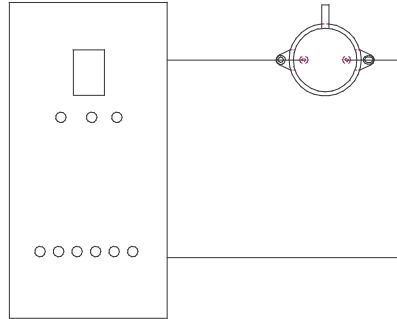

+

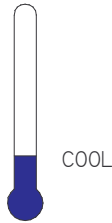

- 1- Dirty pressure tap
- 2- Defect Combex blower
- 3- Defect pressure switch
- 4- Wheel in Combex not there
- 5- Hose missing or defect
- 6- Bad contact on connector

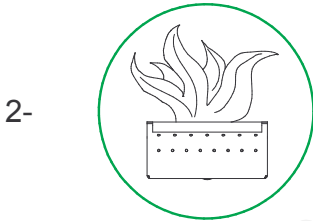

+

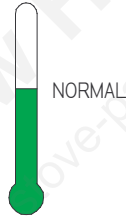

- 1- Dirty pressure tap
- 2- Combex blower overheating
- 3- Something blocked the chimney
- 4- Back draft
- 5- Defect pressure switch

3- The pressure switch is a normally open contact that close when it reach a pressure of 0.1" WC.

## Error code H

There are 4 types of Code H. The type of Code H is determined by the length of time that has passed between the stove is stopped and when one of the L250 automatic temperature sensors opened (or released). The L250 sensors one is located under the auger housing and the other is inside the hopper heat shield.

### H1

L250 automatic sensor open (hot) when the stove is operating normally.

- The auger motor runs full speed for 1 minute every 8 minutes after an initial 8-minute delay.
- The combustion fan stops when the auger motor starts.
- These actions continue until the L250 automatic sensor closes (cold).

### H2

L250 automatic sensor open (hot) between 0 and 2 minutes after normal shut down of the pellet stove.

- The auger motor runs full speed for 1 minute every 8 minutes after an initial 8-minute delay.
- The combustion fan stops when the auger motor starts.
- These actions continue until the L250 automatic sensor closes (cold).

### H3

L250 automatic sensor open (hot) between 2 and 6 minutes after normal shut down of the pellet stove.

- The auger motor stops and the combustion fan is activated for 6 minutes.
- After 6 minutes, the combustion fan stops and the auger motors run full speed until the L250 automatic sensor closes (cold).

### H4

L250 automatic sensor open (hot) 6 minutes after normal shut down of the pellet stove.

- The auger motor runs full speed and the combustion fan stops.
- These actions continue until the L250 automatic sensor closes (cold).

Note:

- If another error code is already displayed on the control panel, the L250 error code takes precedence.
- The L250 automatic sensor must be in the closed position (cold) to reboot the control board.

## L250 Automatic Sensor Identification

Procedure to identify L250 automatic sensor associated with error code **H** on the control board.

There are two L250 automatic sensors inside the stove: one is located under the auger housing and the other is inside the hopper heat shield.

1. Disconnect the stove from the electrical outlet.
2. Open the right panel.
3. Disconnect the black wire from the L250 automatic sensor under the auger housing inside the stove.
4. Disconnect the blue/white wire connected to the black wire leading from the other L250 automatic sensor inside the hopper firewall.
5. Connect the disconnected blue/white wire to the free terminal on the L250 automatic sensor under the auger housing
6. Run the stove under the same conditions and for the same length of time that caused the initial error code H.
7. If you get another error code H, the problem is that the L250 automatic sensor under the auger housing is overheating and triggering a sequence that generates the code H.

Note: During this identification procedure, it is important to keep a close eye on the stove, since the L250 automatic sensor in the hopper heat shield is not functioning.



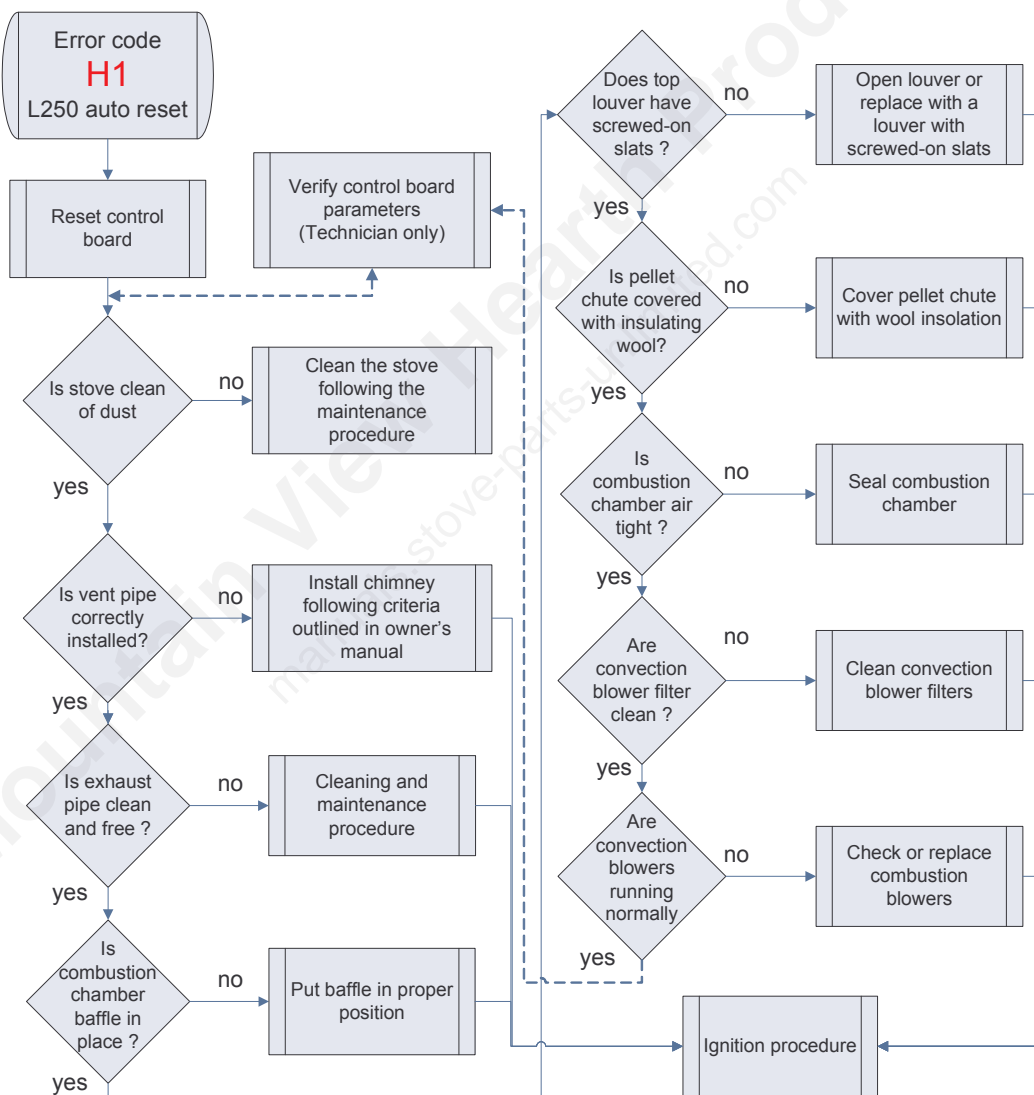

## Error code « H1 »

STOVE STOPS FEEDING PELLETS AND DISPLAYS ERROR CODE "H"		<b>H</b>
<b>Possible Causes:</b>	<b>Possible Solutions:</b>	
1. One of the two L-250 automatic high temperature switches has been tripped.	The L-250 automatic high temperature switches are located on the top and bottom of the auger housing They send a signal to the control board if the auger housing overheats. Wait until the stove cools down AND THEN INSPECT YOUR UNIT. Improper installation, poor maintenance, or a defective or missing component may be causing the stove to overheat. Reset the stove and restart it. Call a technician if you get this code again.	

### Resolving H1 (flow chart)



#### Reset procedure for code error H only

- Series 35 stove and insert: Hold down the  and  buttons simultaneously for approximately 3 seconds
- Series 45 stove: Hold down the  and  buttons simultaneously for approximately 3 seconds

L250 automatic reset

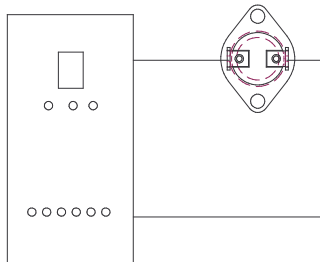

1-

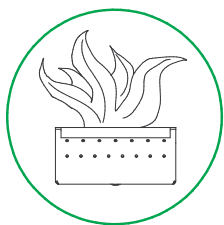

+

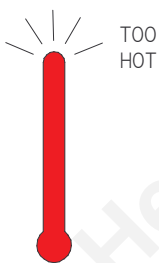

- 1- Stove/chimney need maintenance
- 2- Wool under the chute missing
- 3- Louver kit too close
- 4- Installation is not conform
- 5- Leakage in combustion chamber
- 6- Defect convection blower
- 7- Baffle not in place
- 8- Sealant between chute and hopper



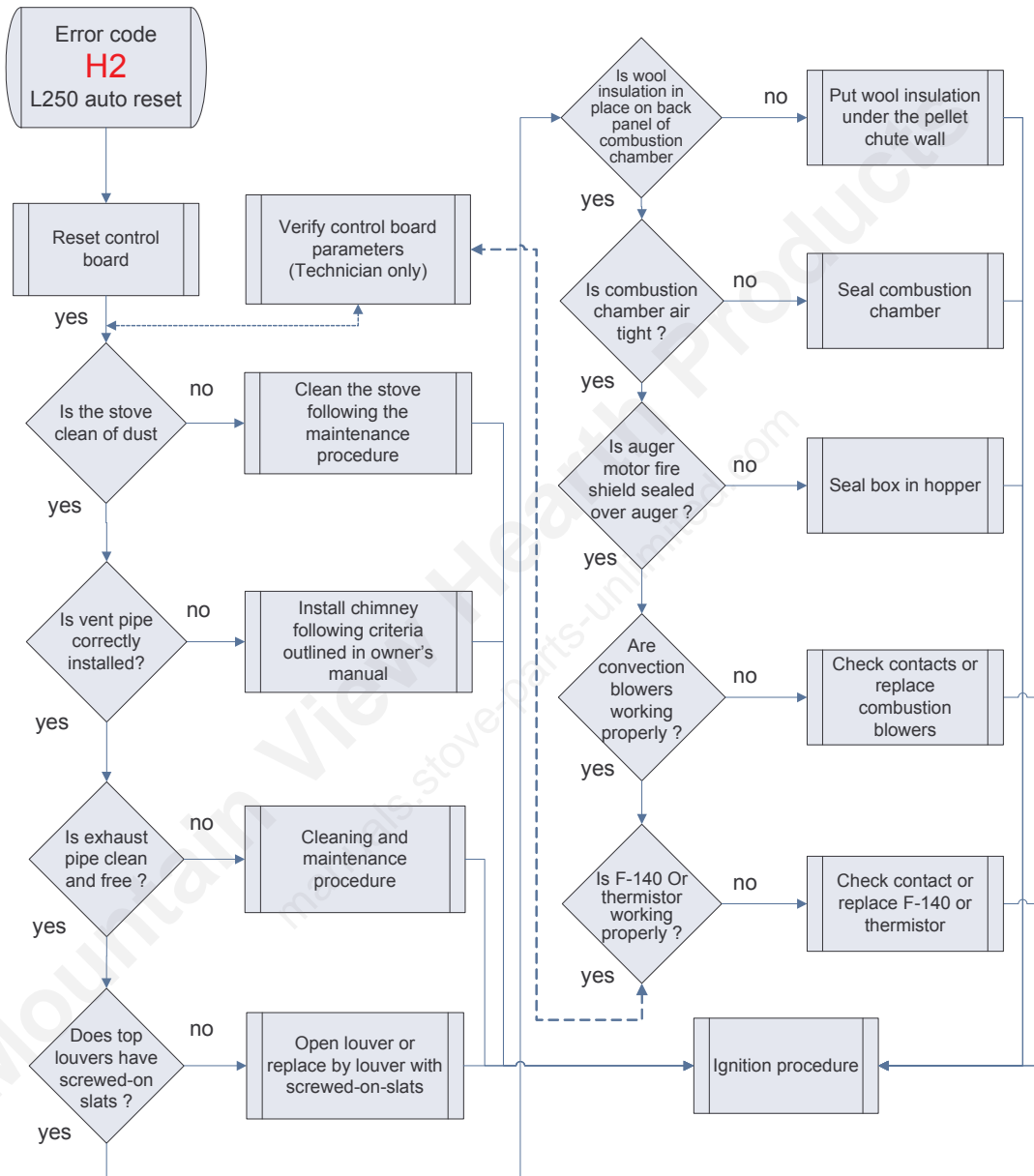

Mountain View Hearth Products  
manuals.stove-parts-unlimited.com

## Error code « H2 »

### Resolving H2 (flow chart)



#### Reset procedure error code H only

- Series 35 stove and insert: Hold down the  and  buttons simultaneously for approximately 3 seconds
- Series 45 stove: Hold down the  and  buttons simultaneously for approximately 3 seconds

L250 automatic  
reset

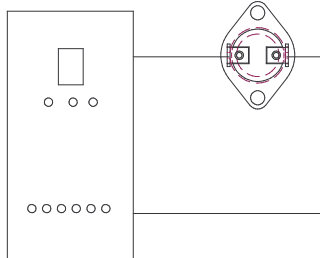

1-

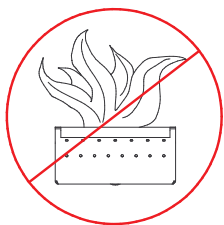

+

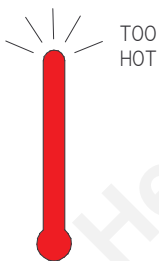



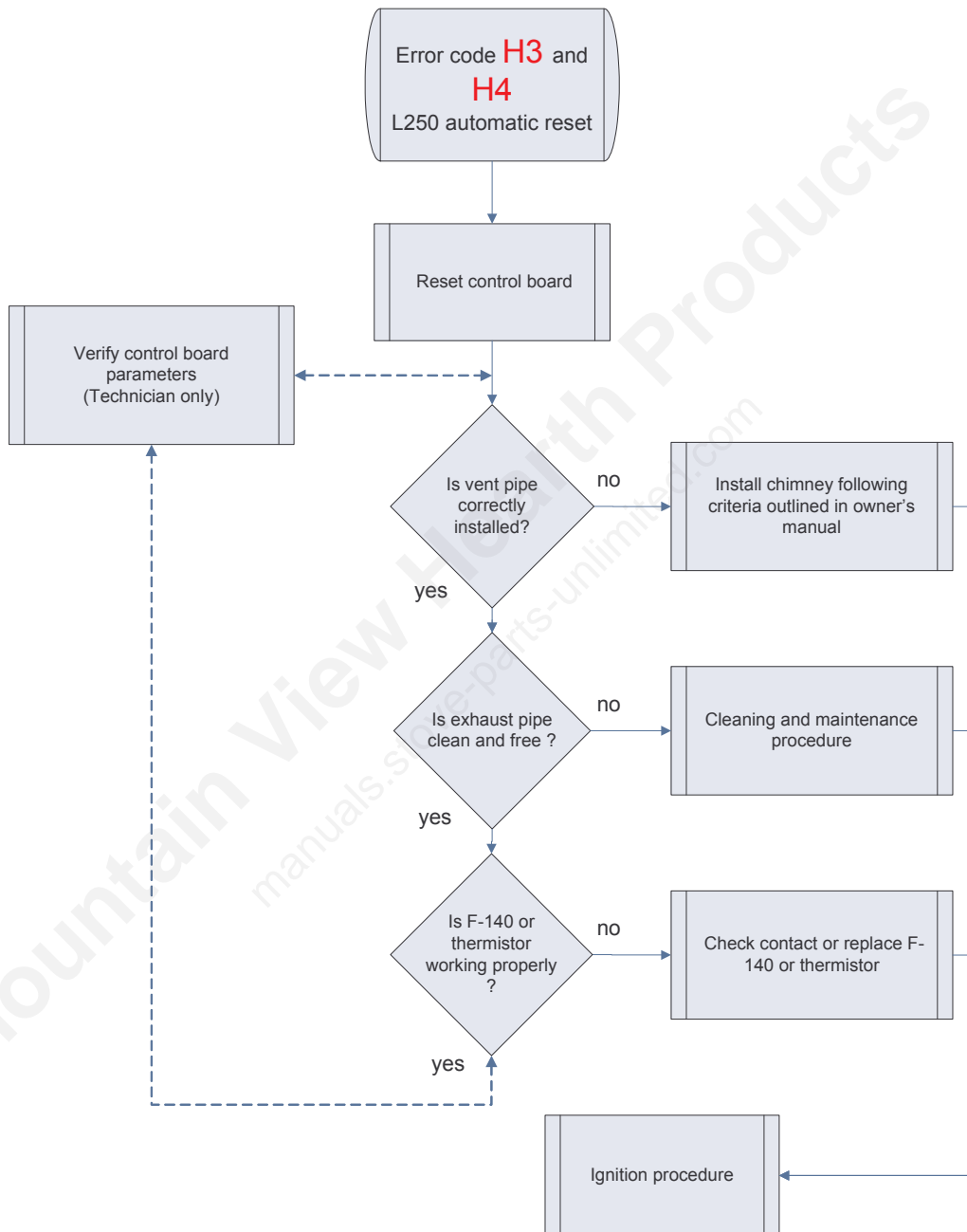

- 1- Stove or chimney needs cleaning
- 2- Wool under the chute missing
- 3- Louver kit too close
- 4- Defect F140
- 5- Installation is not conform
- 6- Leakage in combustion chamber
- 7- Defect convection blower

## Error codes « H3 » and « H4 »

### Resolving H3 and H4 (flow chart)



#### Reset procedure for error code **H** only

- Series 35 stove and insert : Hold down the  and  buttons simultaneously for approximately 3 seconds
- Series 45 stove: Hold down the  and  buttons simultaneously for approximately 3 seconds

L250 automatic reset

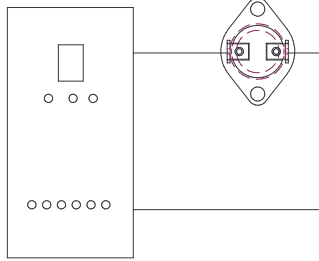

1-



+

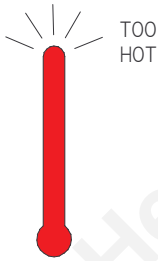

- 1- Stove or chimney needs cleaning
- 2- Defect F140
- 3- Installation is not conform

Mountain View Hearth Products  
manuals.stove-parts-unlimited.com

## Error code « O »

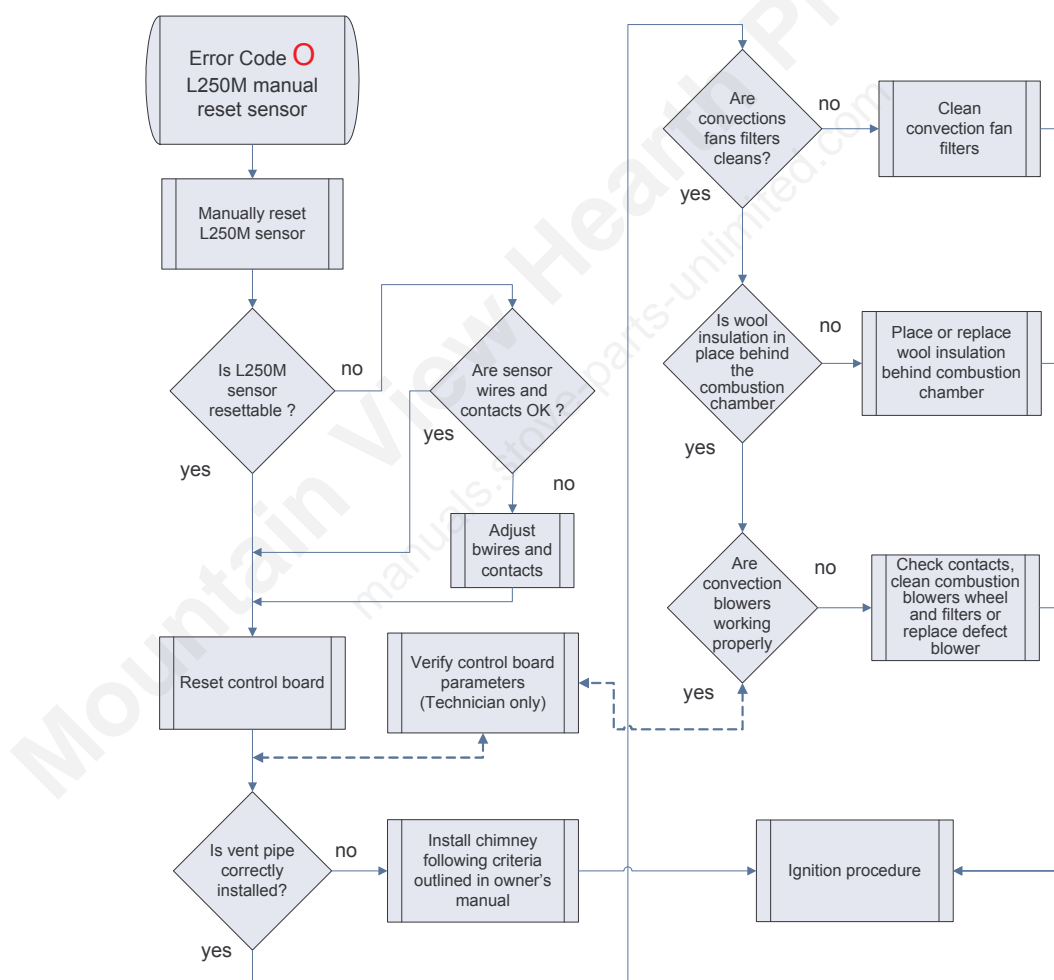

STOVE STOPS FEEDING PELLETS AND DISPLAYS ERROR CODE "O" 	
<b>Possible Causes:</b>	<b>Possible Solutions:</b>
1. The L-250 manual reset high temperature switch has been tripped.	Using the diagram in the owner's manual, locate the L-250 high temperature switch. There is a red button on it. Press the red button. If you hear a click, it means the high temperature limit was tripped. Reset the stove. The stove should now function normally. <b>YOU NEED TO INSPECT YOUR UNIT AT THIS POINT.</b> The F-250 high temperature switch trips if the unit overheats. A problem with another component or with the installation may have caused the stove to overheat. Make sure that the convection blowers are working. If one of the convection blowers has failed, this can cause the unit to overheat. Clean any dust off of the cage and blades of the convection blower. Call your dealer or a technician if you get this code again.

### Resolving O (flow chart)



Note: the L250 manual sensor must be manually reset by pushing the red button before resetting the stove board.

#### Reset procedure for control board error code

- Series 35 stove and insert : push  and restart the stove
- Series 45 stove: push  and restart the stove

L250 manual  
reset

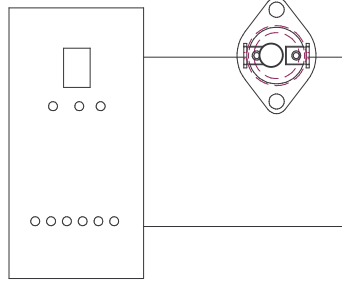

1-

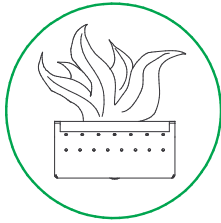

+

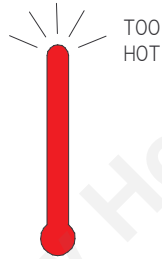

+



- 3- Clean convection blower filters
- 2- Defect convection blower
- 3- Convection blower do not turn at full speed

Mountain View Hearth Products  
manuals.stove-parts-unlimited.com

## Error code « E »



This error code occurs mainly when the hopper is empty

STOVE SHUTS OFF AND DISPLAYS ERROR CODE 	
<b>Possible Causes:</b>	<b>Possible Solutions:</b> (Unplug stove first if possible)
1. The hopper is empty.	Refill the hopper.
2. The burn pot holes are blocked.	Remove the burn pot and clean it thoroughly.
3. The air damper is open too much for the low feed setting.	If the stove is on the low setting, you may need to close the damper all the way. Slide the air supply control toward the minimum setting.
4. The air inlet, interior chambers, or exhaust system is partly blocked.	Follow all cleaning procedures in the maintenance section of the owner's manual.
5. The auger motor has failed.	Remove the auger motor from the auger shaft and try to run the motor separately by pressing the fuel feed button on the control board. If the motor turns, the shaft is jammed on something. If the motor does not turn, the motor is defective or there is a faulty connection with the control board. To remove the auger motor, take the rear panel off the stove body. Loosen the two screws holding the motor to the auger shaft.
6. The auger shaft is jammed.	Remove the auger shaft from the auger housing. Start by emptying the hopper. Take the rear panel off the stove body. Then take the auger motor off by removing the screws that hold the motor to the auger shaft. Once the motor is out, remove the four screws on the steel plate that holds the auger shaft to the auger housing. Then rotate the bottom end of the auger shaft down towards you until you can pull the shaft down out of the stove. After you have removed the shaft, inspect it for bent flights, burrs, or broken welds. Remove any foreign material that may have caused the jam. Also, check the auger housing for signs of damage such as burrs, rough spots, or grooves cut into the metal that could have caused a jam. Clean the auger housing thoroughly to remove all pellet dust.
7. The thermistor or F-140 heat sensor has malfunctioned.	The thermistor or the F-140 is a heat sensor located on the exhaust housing. Its function is to tell the control board that the unit has ignited properly by measuring the heat in the exhaust. The pellet stove will not start feeding pellets at the desired heat setting until it has received a signal from the thermistor or F-140 heat sensor. If the thermistor or F-140 heat sensor is defective, the unit will stop after the ignition cycle. If this situation occurs, call your dealer or technician.

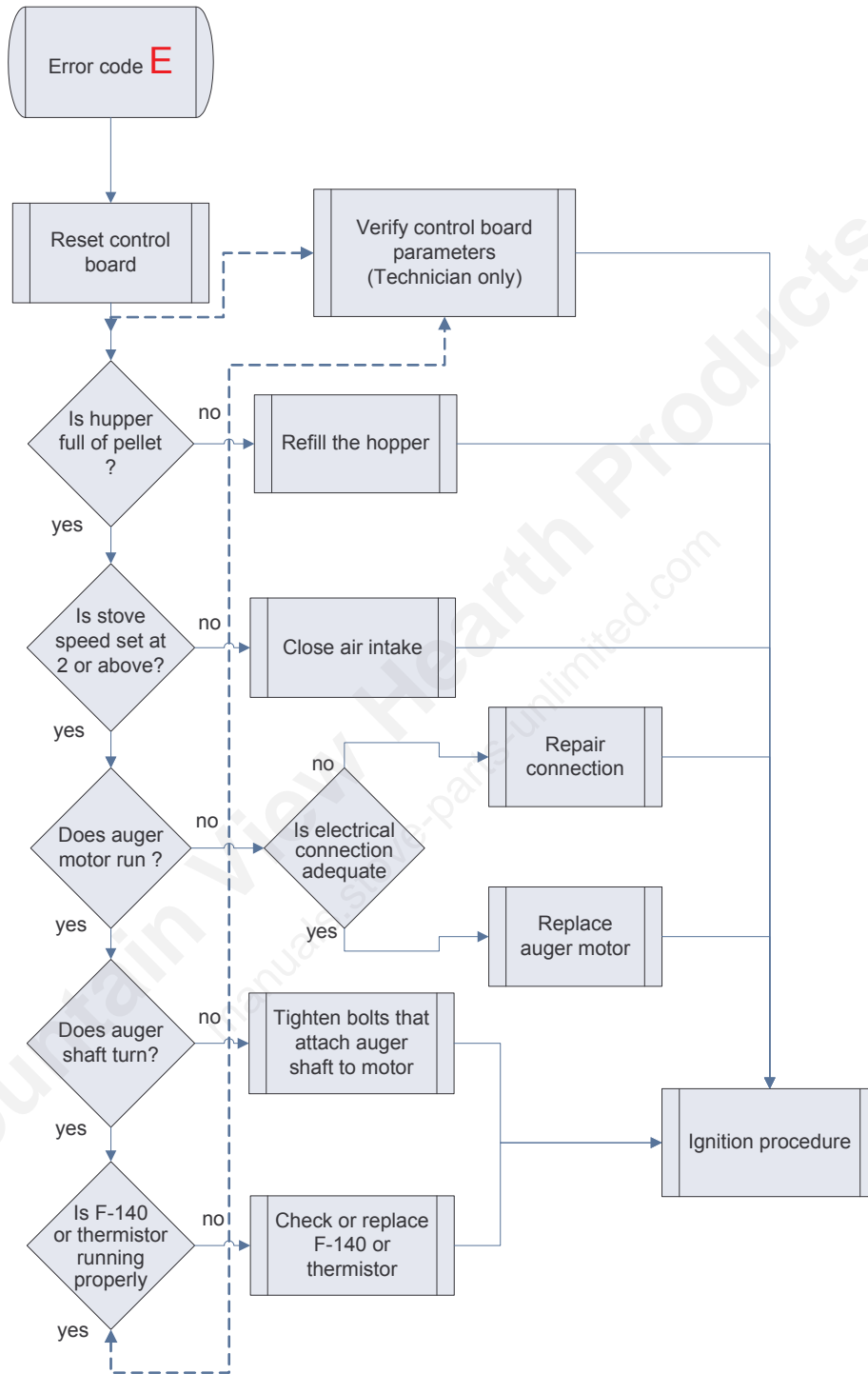
## Resolving E (flow chart)



### Reset procedure for control board error code

- Series 35 stove and insert : push  and restart the stove
- Series 45 stove: push  and restart the stove

# F140

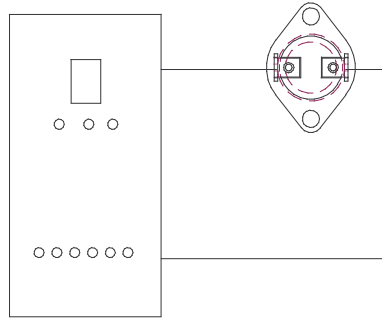

1-		+		+		1- Empty hopper
2-		+		+		1- Defect F140
3-		+		+		1- Too cold ambient temperature, with stove at the first setting 2- Too much draft

## Error code « L »



This code appears during the lighting sequence when the stove will not start.

STOVE FEEDS PELLETS, BUT WILL NOT IGNITE AND DISPLAYS ERROR CODE		
<b>Possible Causes:</b>	<b>Possible Solutions:</b>	
1. Air damper too open for ignition.	Adjust the air supply to the minimum setting for startup. In some situations, it may be necessary to have the damper completely closed for ignition to take place. Once there is a flame, the damper can be adjusted to the desired feed setting.	
2. Blockage in igniter tube or igniter tube inlet.	Remove the burn pot and clean it thoroughly. Make sure that all openings are clear. Find the place where the igniter tube comes out of the burn pot housing. It is a small tube located on the back of the burn pot housing. Make sure it is clear. Make sure there is no debris around the igniter element or inside the igniter tube.	
3. Defective igniter element.	Supply power directly to the igniter element. Watch the tip of the igniter from the front of the stove. After about 2 minutes, the tip should glow. If it does not, the element is defective and must be replaced. You may need a technician to perform this test.	
4. The thermistor or F-140 heat sensor has malfunctioned.	The thermistor (F140) is a heat sensor attached to the exhaust housing. Its function is to tell the control board that the unit has ignited properly by measuring the temperature of the exhaust. The stove will not feed pellets at the desired heat setting until it has received a signal from the thermistor heat sensor. If the thermistor heat sensor is defective, the unit will go out and stop after the ignition cycle. If this situation occurs, call your dealer or technician.	
5. The control board is not supplying power to the igniter.	Check the voltage going to the igniter during ignition. It should be a full current. If the voltage is lower than full current, check the wiring. If the wiring is functional and properly connected, the board is defective. You will need a technician to perform this test.	
6. The burn pot gaskets are missing or have to be replaced.	The burn pot gaskets are on the metal ring at the bottom of the burn pot. These gaskets prevent heat loss from the igniter to achieve faster ignition.	

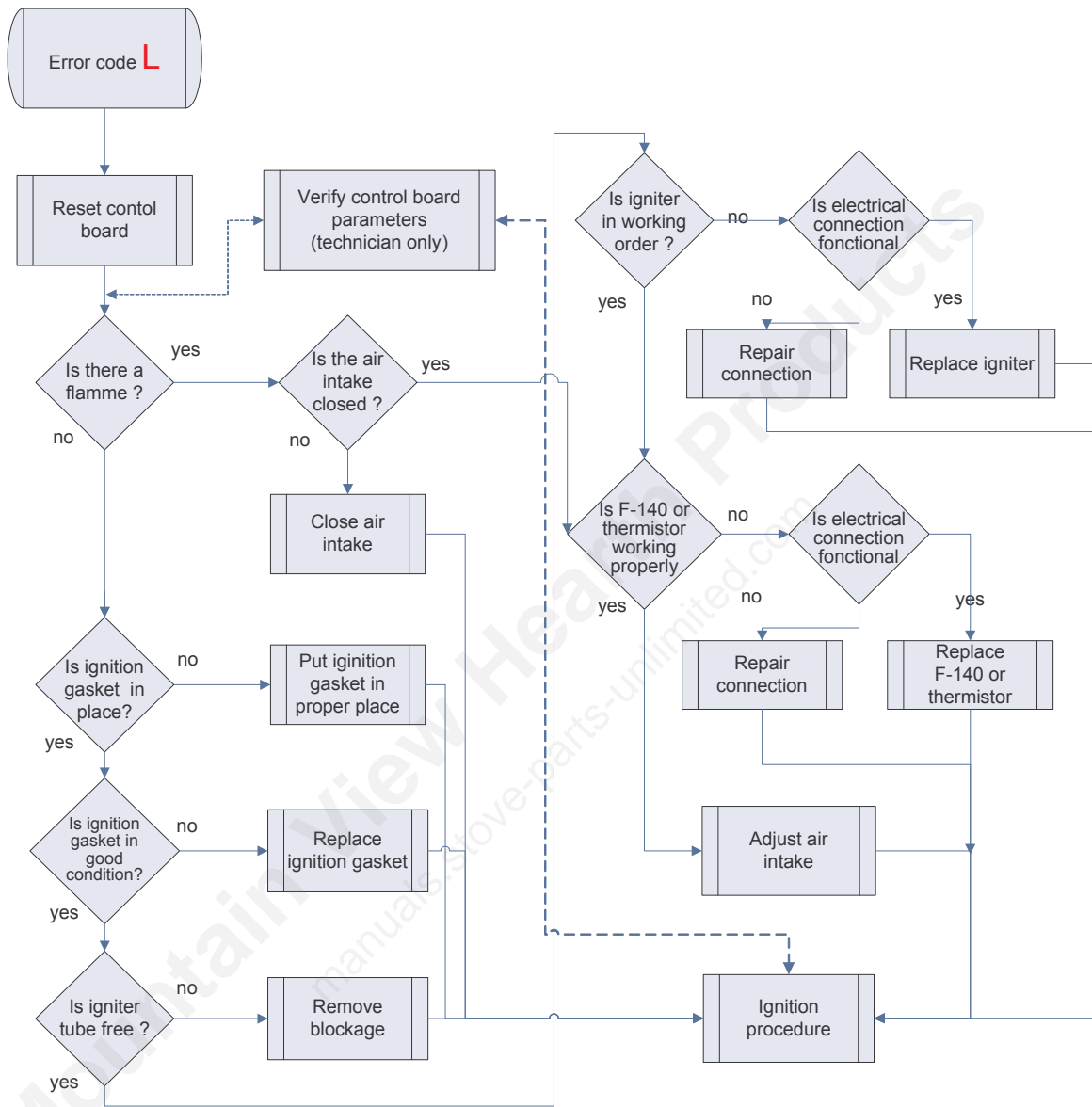
## Resolving L (flow chart)



### Reset procedure for control board error code

- Series 35 stove and insert: push  and restart the stove
- Series 45 stove: push  and restart the stove

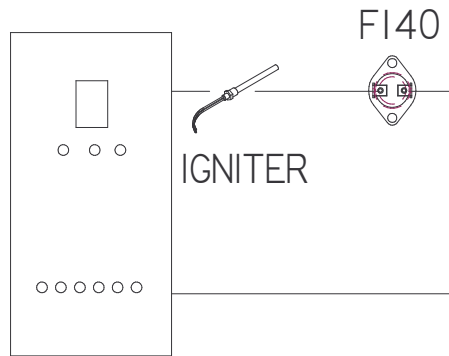

1- + + 1- Empty hopper

2- + + 1- Gasket missing  
2- Dirty pot  
3- Wet pellet  
4- Leakage in combustion chamber  
5- Defect hopper switch  
6- Defect igniter  
7- Defect gear motor

3- + + 1- Defect F140



## Error code « d »

STOVE STOPS FEEDING PELLETS AND DISPLAYS ERROR CODE "d"		
<b>Possible Causes:</b>	<b>Possible Solutions:</b>	
1. The hopper lid has stayed open for more than 3 minutes.	As a security measure, the auger stops turning and feeding pellets as soon as the hopper lid opens. It will resume normal operation as soon as the hopper lid is closed. If the hopper lid stays open for more than 3 minutes, the unit will stop and a code "d" will appear on the control board. Close the hopper lid. Reset the unit and start it again.	

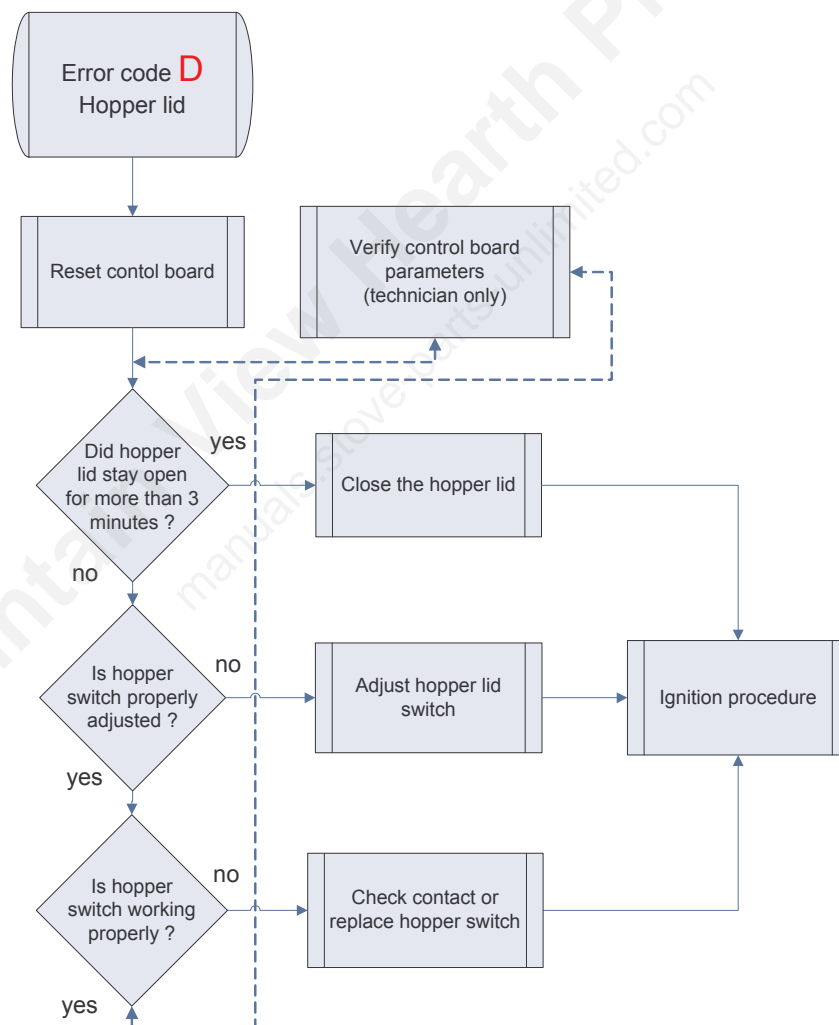
## Resolving d (flow chart)



### Reset procedure for control board error code

- Series 35 stove and insert : push  and restart the stove
- Series 45 stove: push  and restart the stove

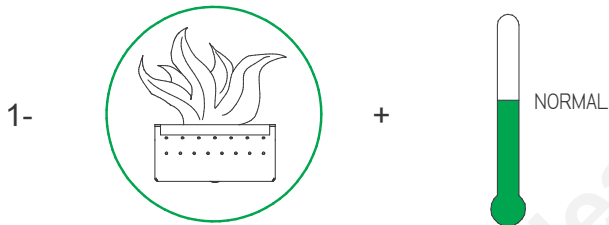
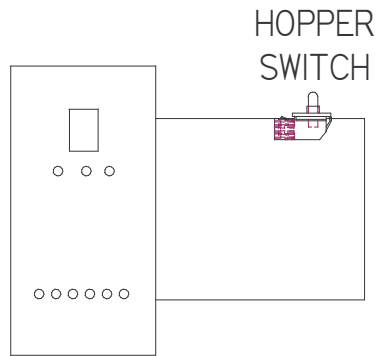

- 1- Hopper lid stay open for more than 3 minutes
- 2- Hopper switch not adjusted
- 3- Defect hopper switch
- 4- Shorted wiring
- 5- Connection in the switch or in the connector are not at the good position

Mountain View Hearth Products  
 manuals.stove-parts-unlimited.com

## Error code « n »



This error code does not stop the stove from functioning, but operating the stove while the code is displayed may damage the electric or electronic components.

THE STOVE IS RUNNING BUT DISPLAYS ERROR CODE 	
<b>Possible Causes:</b>	<b>Possible Solutions:</b>
<ol style="list-style-type: none"> <li>The polarity is reversed on the electric outlet and/or in the wire connection between the power cord and the control board</li> <li>Non-existent ground connection or not connected on the electrical outlet</li> </ol>	Ensure the power cord is properly connected and that the stove is grounded.

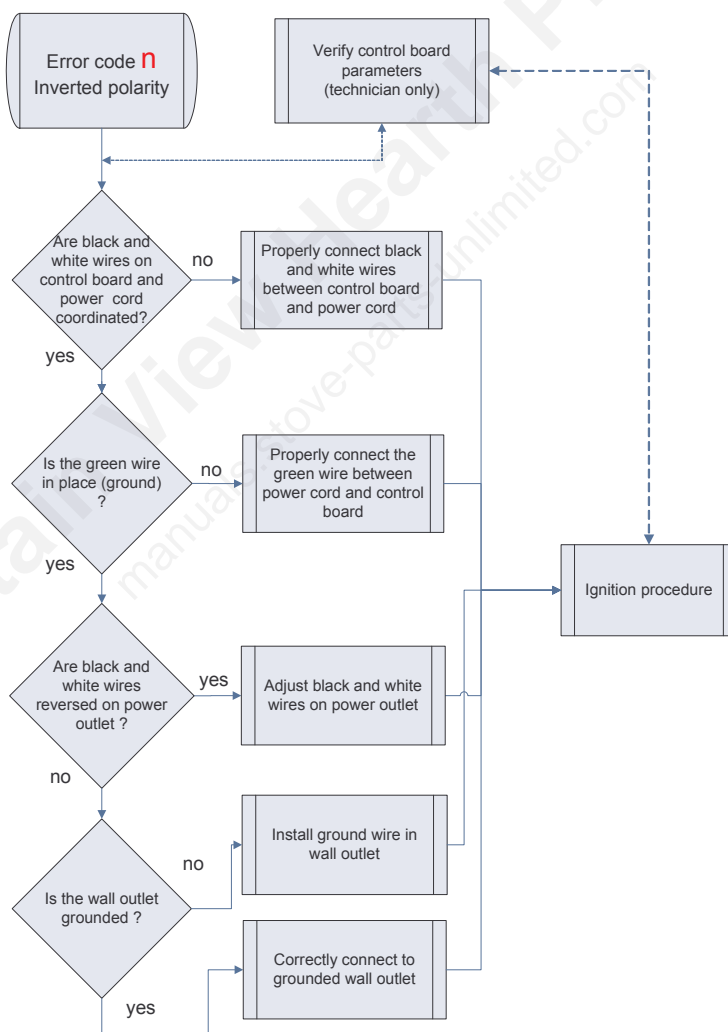
### Resolving n (flow chart)



### Reset procedure for control board error code

- Series 35 stove and insert: push  and restart the stove
- Series 45 stove: push  and restart the stove

## Error code « C »

THE STOVE IS RUNNING BUT DISPLAYS ERROR CODE 	
<b>Possible Causes:</b> Error generated by a power failure while the stove was running.	<b>Possible Solutions:</b> You do not need to reset the stove. The stove will restart on the initial setting by itself once it cools off. Note: For a short power failure (less than 5 seconds), the stove will continue to function at the selected speed.



## Error code « I »

STOVE FEEDS PELLETS, BUT WILL NOT IGNITE AND DISPLAYS ERROR CODE 	
<b>Possible Causes:</b> 1. The igniter fuse on the control board has blown.	<b>Possible Solutions:</b> Remove the control board and check at the back to see whether the F3 fuse is good; if not replace it with a 5 Amp 250V fuse. Plug the stove back in and try to run the unit.

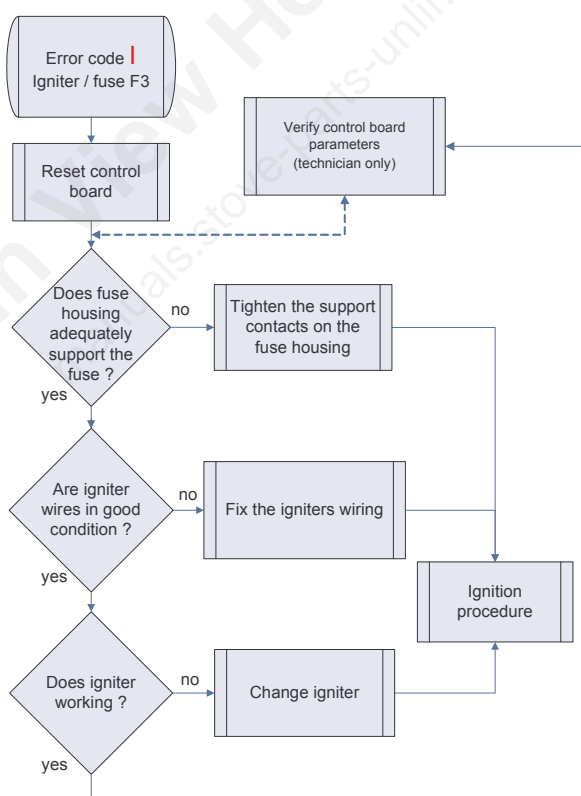
## Resolving I (flow chart)



### Reset procedure for control board error code

- Series 35 stove and insert : push  and restart the stove
- Series 45 stove: push  and restart the stove

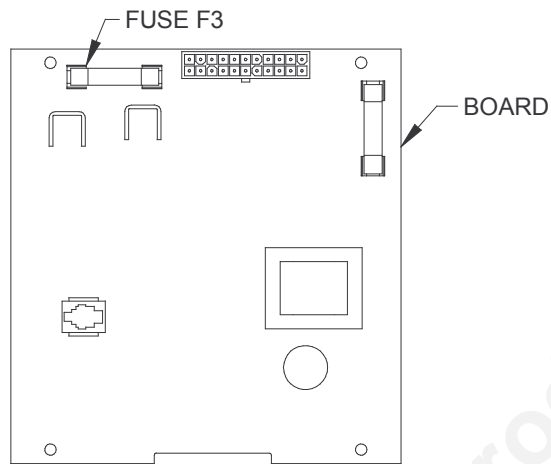

Possible cause :

- 1 - Defective igniter
- 2 - Shorted wiring
- 3 - Socket do not hold fuse tightly

Mountain View Hearth Products  
manuals.stove-parts-unlimited.com

## Testing procedure for series 35 pellet stove and insert:

To get into the testing mode:

press and hold the THERMOSTAT BUTTON  and the  
RESET BUTTON  for 3 seconds.

### Part #1 Display testing

- Every segment & light of the display will turn on one after the other.

If one segment or light is not functioning, replace the display board.

Press I/O button to continue

### Part #2 Button testing

The display will flash the button that needs to be pressed.

- I/O
- Thermostat
- Reset
- Auxiliary
- Convection fan speed reducer
- Auger manual feed
- Each speed level (from 1 to 6)

I/O

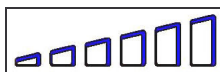

If a button does not light up, verify that the ground is correctly connected.  
If correctly connected & no light, replace the display board.

Press I/O button to continue

### Part #3 AC Voltage verification

- The display will show the supplied AC voltage to the control board.

If the voltage is 120 Volts, it will show: **1, 2, 0** and **V** with a slight pause before it start again.

*The display voltage should be between 110 Volts and 125 Volts.*

Press I/O button to continue

### Part #4 AC frequency verification

- The display will show the AC frequency (Hertz) supplies to the board.

If the frequency is 60 Hz, it will show: **0, 6, 0** and **H** with a slight pause before it start again.

*The frequency should be between 57Hz and 63Hz.*

Press I/O button to continue

### Part #5 AC polarity verification

- The display will show the AC polarity to the board.

If a "**P**" is shown, the polarity is correct;

If an "**F**" is shown, the polarity is inverted or the ground wire is not correctly connected.

Press I/O button to continue

### Part #6 Convection blower verification

- The display will show 3 digit followed by a "**C**" to indicate that we are testing the Convection fan.

If one of the motors does not turn at full speed or does not work, verify the connection or replace the motor.

Press and hold the FEED SCREW BUTTON  for 3 seconds.

### Part #7 Exhaust blower verification

- The convection blowers will stop
- The display will show 3 digit followed by “E” to indicate that we are testing the Exhaust fan.
- The exhaust blower will turn on.
- At this point, the thermostat LED will turn ON if pressure switch is detected and running properly.

**If the motor does not run at full speed or does not work, verify the connection or replace the motor.**

Press and hold the FEED SCREW BUTTON  for 3 seconds.

### Part #8 Igniter verification

- The exhaust blower will turn off.
- The igniter will turn ON.
- The display will show in order; **I, G, N, I, T, O, R.**
- Check at the end of the igniter or at the back of the unit if you see the igniter glowing. It could take up to a minute.

**If the igniter does not light, verify the connection or replace it.**

Press and hold the FEED SCREW BUTTON  for 3 seconds.

### Part #9 Auger motor verification

- The igniter will turn OFF
- The display will show in order; **A, U, G, E, R.**
- The auger motor will turn ON.

**If one of the motors does not work, verify the connection or replace the motor.**

Press and hold the FEED SCREW BUTTON  for 3 seconds

## Part #10 Inputs checking

- The display will show in order; **I, N, P, U, T, S**.
- The LEDs are used to indicate the status of each sensor.

If the contact is **OPEN**, the light will be **ON**;

If the contact is **CLOSE** the light will be **OFF** or **50% ON** for the 6 speed indicator.

Normal status of the light	Light position equivalent component	Parts description
On*	1st heating level*	F-140 *
On	2nd heating level	F-160
Off	3rd heating level	L-250
Off	4th heating level	L-250 Manual Reset
On	5th heating level	Thermistor
Off	6th heating level	Igniter fuse or igniter (F3)
On	" RESET " LED	Pressure switch
Off	" I/O " LED, when the hopper is close	Hopper lid switch
On	"THERMOSTAT" light	Thermostat terminal

Note: \* the light in position 1 is ON but not associated with any component

**Note: If one of the LED is not in the normal state, verify all the connection from the board to the component. If the problem is still remained, replace the defective component.**

Press I/O to continue

## Part #11 Thermistor verification

The temperature of the exhaust blower is read by the Thermistor in °F

If the temperature shown by the Thermistor is **0 2 3**, it is probably defective or disconnected.

**In that case, verify the connection or replace the Thermistor.**

Press I/O to continue

### **Part #12**      **EEPROM test**

- If EEPROM is correct, the display will show in order; **E, E, P, P, A, S, S**.
- If EEPROM is defective it will show; **E, E, P, F, A, I, L**.

**For this last case, change the control board.**

Press I/O to continue

### **Part #13**      **Watching mode checking**

- The display will show an "r" followed by **V E R** and number related to the control board software
- Please note these numbers in case of SBI technical service department ask for it.



## **END OF THE TEST PROCEDURE FOR PELLET STOVE 35 AND INSERT SERIES ELECTRICS COMPONENTS**

### **Thermistor temperature reading for 35 series**

To read the temperature of the Thermistor :

- Press and hold SPEAKER SIGN button and 6th LEVEL button for 3 seconds when the unit is stopped.
- The temperature read by the Thermistor is display until you get out of this mode.
- To cancel this function, press and hold SPEAKER SIGN button and 6th LEVEL button for 3 seconds when the unit is stopped.

## Testing procedure for series 45 pellet stove:

To get into the testing mode:  
press and hold the **SPEAKER SIGN BUTTON**  and  
the **FEED SCREW BUTTON**  for 3 seconds.

### Part #1 Display verification

- Each segment & LED light will turn ON one after the other to verify their status.

If one segment or light is not functioning, replace the control board.

Press any key to continue

### Part #2 Display verification

- Every segment on the display and each LED will turn ON at the same time.

If one of the segment or a light is not working, replace the control board

Press any key to continue

### Part #3 Button verification

- A number will appear on the segment display, press the button that corresponds with the number shown below.

1 = Mode



2 = Reset



3 = Speaker sign



4 = Manual Feed



5 = Less



6 = Plus



If one of these buttons is not working, replace the control board.

### Part #4 AC Voltage verification

- The AC voltage will appear on the segment display.

If the voltage is 120 Volts, it will show: **1, 2, 0** and **V** with a slight pause before the cycle runs again.

*The display voltage should be between 110 and 125 Volts.*

Press any key to continue

### Part #5 AC frequency verification

- The AC frequency (Hertz) that is supplied to the board will appear on the segment display.

If the frequency is 60 Hz, it will show: **0, 6, 0** and **H** with a slight pause before it start again.

*The frequency should be between 57Hz and 63Hz.*

Press any key to continue

### Part #6 AC polarity verification

- The board will verify the AC polarity.

If a **P** is shown, the polarity is correct;

If an **F** is shown, the polarity is inverted or the ground wire is not correctly connected.

Press any key to continue

### Part #7 Convection blower verification

- 3 digits followed by the letter **C** will appear to indicate that we are in testing mode of the convection fan.

If the convection fan does not turn on, verify the connection.

Press simultaneously SPEAKER SIGN BUTTON  and the FEED SCREW

BUTTON  for 3 seconds

### Part #8 Exhaust blower verification

- 3 digits followed by the letter **E** will appear to indicate that we are in testing mode of the exhaust fan.

**If the exhaust fan does not turn on, verify the connection.**

Press simultaneously SPEAKER SIGN BUTTON  and the FEED SCREW BUTTON  for 3 seconds

### Part #9 Igniter verification

- The igniter will turn on;
- The following letters will appear in order: **I, G, N, I, T, O, R**;
- Verify that the igniter is glowing. Note that it could take up to three minutes for the igniter to glow.

**If the stove igniter doesn't work, verify the connection.**

Press simultaneously SPEAKER SIGN BUTTON  and the FEED SCREW BUTTON  for 3 seconds

### Part #9 Auger motor verification

- The auger motor will turn on;
- The following letters will appear in order; **A, U, G, E, R**.

**If the auger motor does not turn, verify the connection.**

Press simultaneously SPEAKER SIGN BUTTON  and the FEED SCREW BUTTON  for 3 seconds

## Part #11 Security sensors verification

- The following letters will appear in order; **I, N, P, U, T, S**;
- The LED lights are used to indicate the status of each input;

If the contact is **OPEN**, the light is **ON**;  
 If the contact is **CLOSE** the light is **OFF**.

The following picture shows the normal status of the LED lights on the control board.

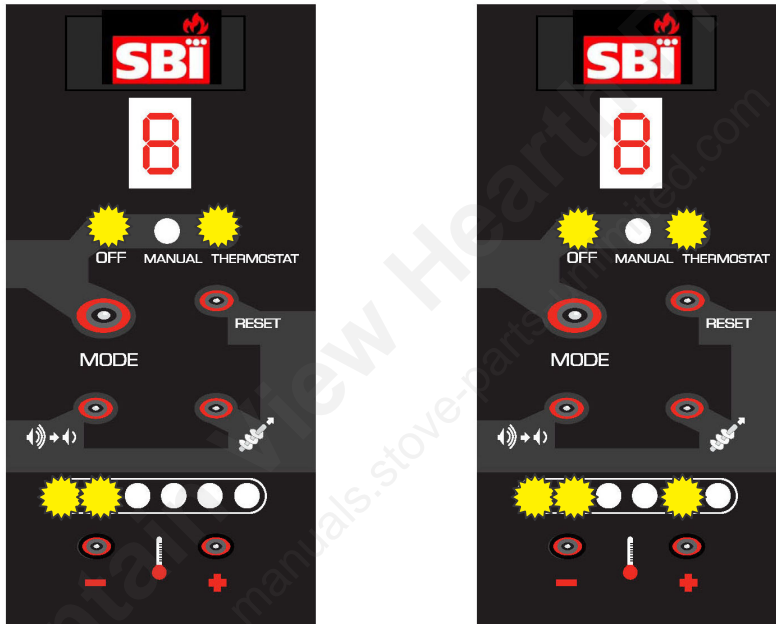

Normal state of the LED	Light position equivalent component	Part description
On*	1st heating level*	F-140 *
On	2nd heating level	F-160
Off	3rd heating level	L-250
Off	4th heating level	L-250 Manual Reset
On **	5th heating level**	Thermistor **
Off	6th heating level	Igniter fuse or igniter (F3)
On	" OFF " position	Pressure Switch
Off	" MANUAL " position, when the hopper is close	Hopper lid switch
On	" THERMOSTAT " position	Thermostat terminal

Note: \*A stove with Thermistor, the light in position 1 is lit but is not associated to any component

\*\* Stove with Thermistor only

**N.B. If one of the LED is not in the normal state, verify all the connection from the board to the input. If the problem is still there, replace the defective component.**

Press any button to continue.

### **Part #12 EEPROM test**

- If EEPROM is correct, the display will show the following letters in order: **E, E, P, P, A, S, S**;
- If EEPROM is defective, it will show: **E, E, P, F, A, I, L**.

**If EEPROM fails change the board.**

Press any button to continue.

### **Part #13 Board version verification**

The display will show an "r" followed by **V E R** and number related to the control board software

Take a note of these numbers in case of SBI technical service department demand.

## **END OF THE 45 SERIES PELLET STOVE TEST PROCEDURE**

### **Thermistor temperature reading for 45 series**

To read the temperature of the Thermistor :

- Press and hold FEED SCREW button and PLUS button for 3 seconds when the unit is stopped.
- The temperature read by the Thermistor is display until you get out of this mode.

To cancel this function, press and hold FEED SCREW button and PLUS button for 3 seconds when the unit is stopped.