

Installation Instructions

UPDATE: NOVEMBER 23, 2004

AUGER MOTOR

Replacement Procedure:

NOTE: Always Disconnect Power Before Performing Service Work

You may find it easier to remove the appliance from the venting, if already installed, and pull it away from the wall.

Tools Needed:

1/4" Hex Nut setter & Driver 5/32 L Key
Side Cutters or Knife RTV Silicone

Removal Steps

1. Unplug the stove power cord from the wall outlet.
2. To gain access to the back of the appliance, remove the 1/4" hex screws from the four corners of the REAR SLOTTED ACCESS PANEL. This is located on the back lower side of the appliance.
3. To gain access to the side of the appliance, remove the 1/4" hex screws from the LEFT HAND SIDE PANEL. These are located on the back left hand side corner of the unit.
4. Locate the position of the SET SCREW (F) located on the LOCK COLLAR (E). You will find it easier to service if the set screw is facing directly toward the combustion fan or left hand side panel.
5. You may have to plug the unit back in, Press the Start button to activate the auger motor. When the set screw is facing directly toward the left hand side panel, unplug the stove to stop the auger cycle.
6. Disconnect the two wires from the auger motor.
7. Loosen the SET SCREW (F) on the lock collar.
8. Remove the SET SCREW (B) completely from the auger mounting bracket. This is found on the control board side of the auger, and secures the auger motor to the auger feed tube.
9. Gently slide the motor backwards and away from the auger shaft and tube.

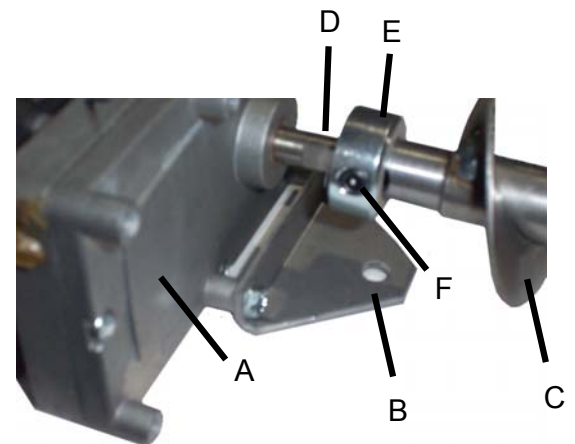
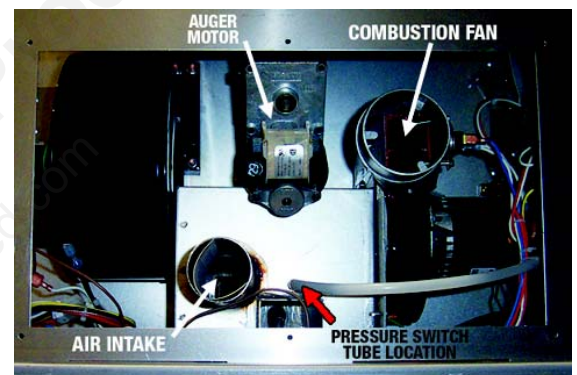

B

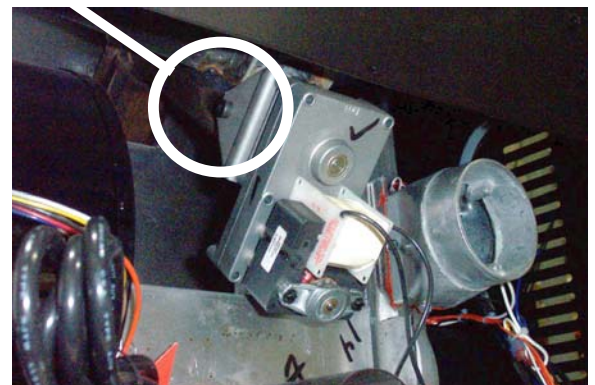

Installation Instructions

Replacement Procedure:

Installation of New Auger Motor

1. Before installing the new auger motor, ensure that the flat spot on the auger motor shaft (D) is lined up in the same direction as the auger shaft set screw (F). Both should be facing directly toward the left hand side panel (G).
2. You may have to plug the motor in and start the control board to allow the auger motor shaft to turn in the direction you want.
3. Slide the new auger motor (A) onto the auger shaft (C).
4. Re-install the set screw on the mounting bracket first (B) Hand tighten as much as possible, then use the 5/32 L Key to tighten firmly.
5. Firmly hand tighten the set screw found on the lock collar (F). Use the 5/32 L key to tighten firmly.
6. Reconnect the two wires to the auger motor.
Note: If the connectors do not reach the motor, you may have to snip one or two wire ties located close to the connection ends.
7. Plug stove in and start the control board to confirm that everything is working correctly.
8. Re-install the rear access panel
9. Re-install the left hand side panel.
10. Slide stove back into place.
11. Re-install the Approved PL Venting or Stainless Liner to the exhaust outlet of the combustion fan. Make sure ALL joints and connections are sealed using only HIGH TEMP RTV Silicone.

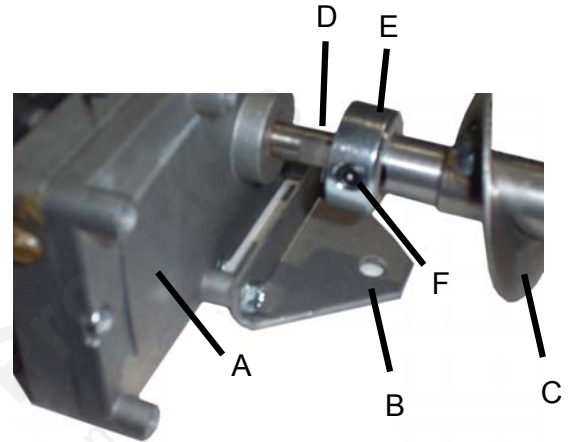

Final Step

Start -Up the appliance and go through the complete START UP procedure.

In the event you need more information please **contact DGI at 1-877-303-3134 or 1-866-456-9269** and ask for the Customer Service Department.