

QUADRA-FIRE

North America's Best

MODEL 1100-I HEARTH CLASSIC PELLET INSERT INSTALLATION, OPERATION, AND MAINTENANCE INSTRUCTIONS

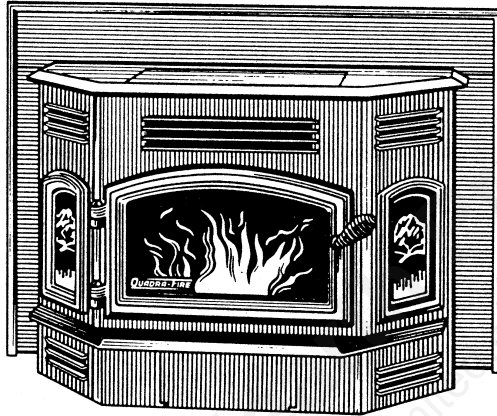

CONGRATULATIONS—You are now the proud owner of one of the finest inserts in the world for your home—the **QUADRA-FIRE!** Now before installing your insert and building your first fire, record the serial number on the warranty card. The serial number is located on the safety label on the back wall of the hopper.

PLEASE READ ALL OF THE OWNER'S MANUAL AND SAFETY NOTES

IMPORTANT SAFETY NOTES

1. When installing your insert, particular attention should be paid to fire protection. If this unit is not properly installed, a house fire may result. For your safety, follow the installation instructions, and contact local building or fire officials about restrictions and installation inspection required in your area.
2. Read power supply section of component information (page 9) before you plug in the insert.
3. Always unplug the insert before cleaning or servicing.
4. Do not connect the insert to a chimney flue already serving another appliance.
5. Do not connect this heater to any air distribution duct or system.
6. The insert operates with a negative pressure firebox and a positive pressure exhaust. It is imperative that the chimney system be airtight and installed correctly.
7. Dispose of all ashes in a metal container.
8. Do not burn garbage or flammable fluids such as gasoline, naphtha or engine oil.
9. Do not use chemicals or fluids such as gasoline, lantern fuel, kerosene, or charcoal lighter fluid to start or freshen up a fire in this insert.
10. **HOT WHILE IN OPERATION.** Keep children, clothing, flammable liquids and furniture away from heater. Contact may cause skin burns.
11. Comply with all minimum clearances to combustibles as shown on page 5.
12. The Quadra-Fire 1100-I is tested and approved for pelleted biomass fuel only. Burning of any other type of fuel voids your warranty!
13. Aladdin Hearth Products, manufacturer of the 1100-I pellet insert, reserves the right to alter its products, their specifications and/or price without notice.

ALADDIN HEARTH PRODUCTS, GRANTS NO WARRANTY, IMPLIED OR STATED, FOR THE INSTALLATION OR MAINTENANCE OF THIS UNIT AND ASSUMES NO RESPONSIBILITY FOR ANY CONSEQUENTIAL DAMAGE(S).



(Revised 3/98)

401 N. Wynne Street
Colville, WA 99114

SAVE THESE INSTRUCTIONS

www.hearth.com/quad
aladdin@plex.com

NOTES

Mountain View Hearth Products
manuals.stove-parts-unlimited.com

TABLE OF CONTENTS

	<u>Page</u>
Safety label	4
Listings and specifications	5
Dimensions	5
Minimum opening for masonry and zero clearance	5
Installation	
Masonry and zero clearance	6
Minimum clearances to combustibles when installed as a built-in	6
Direct connect with outside air	7
Full reline with outside air	7
Direct connect without outside air	7
Installed as a built-in (outside air optional)	7
Floor protection	8
Chimney and exhaust connections	8
Mobile home installation	8
Vent termination requirements	8
Power supply	9
Thermostat control installation	9
Venting graph	10
Feed adjustment instructions	11
Outside air kit installation instructions	11
Operating instructions	12
Cleaning and maintenance	13
Component information	15
Troubleshooting	17
Notes	19
Lifetime warranty	20
Warranty card	Insert

SAFETY LABEL

(FOUND ON INSIDE OF RIGHT FACE SIDE OF INSERT)

Serial No.	Report No. 632-210300	Report Date June, 1992	Model: QUADRA-FIRE 1100-I
-------------------	---------------------------------	----------------------------------	--

Report No. 632-210300	Report Date June, 1992	Model: QUADRA-FIRE 1100-I	Serial No.
---------------------------------	----------------------------------	--	-------------------

Listed Solid Fuel (Pellet Type) Accessory/Insert
 Also suitable for Mobile Home installation. This pellet burning appliance has been tested and listed for use in Manufactured Homes in accordance with OAR 814-23-900 through 814-23-909.

Warnock Hersey



"PREVENT HOUSE FIRES"

Install and use only in accordance with manufacturer's installation and operating instructions. Contact local building or fire officials about restrictions and inspection in your area.

WARNING - FOR MOBILE HOMES: Do not install appliance in a sleeping room. An outside combustion air inlet must be provided. The structural integrity of the mobile home floor, ceiling and walls must be maintained.

Refer to manufacturer's instructions and local codes for precautions required for passing chimney through a combustible wall or ceiling. Inspect and clean vent system frequently in accordance with manufacturer's instructions.

Use a 3" or 4" diameter type "L" or "PL" venting system.

Do not connect this unit to a chimney serving another appliance.

Manufactured by

ALADDIN
 HEARTH PRODUCTS
 401 N. Wynne
 Colville, WA 99114

Tested To:
 UL 1482, ULC S627, APFI, (UM) 84-HUD
FOR USE ONLY WITH PELLETIZED WOOD FUEL.

Input Rating: 50,000 BTU/HR

Electrical Rating: 115 VAC, 60 Hz, Start 4.1 Amps, Run 1.1 AMPS.

Route power cord away from unit.

DANGER: Risk of electrical shock. Disconnect power supply before servicing. Replace glass only with 5mm ceramic available from your dealer.

To start, set thermostat above room temperature, the stove will light automatically. To shutdown, set thermostat to below room temperature. For further instruction refer to owner's manual.

Keep viewing and ash removal doors tightly closed during operation.

INSERT CLEARANCE DIAGRAM

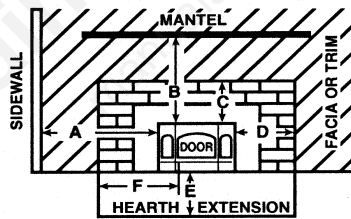

Minimum Clearance to Combustible Materials.

A	2 in/ 50 mm
B	9 in/230 mm
C	0 in/ 0 mm
D	0 in/ 0 mm
E	6 in/150 mm
F	8 in/200 mm

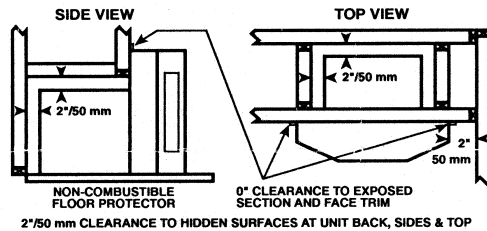

AS A BUILT-IN UNIT

A floor protector is required with a minimum R value of 3. Insert cavity must be vented.

U.S. ENVIRONMENTAL PROTECTION AGENCY

This model is exempt from EPA certification under 40 CFR 60.531 by definition [Wood Heater (A) "Air-to-Fuel Ratio"].

Date of Manufacture

1998 1999 2000 Jan. Feb. Mar. Apr. May June July Aug. Sept. Oct. Nov. Dec.



DO NOT REMOVE THIS LABEL

Made in U.S.A.

QUADRA-FIRE 1100-I DIMENSIONS

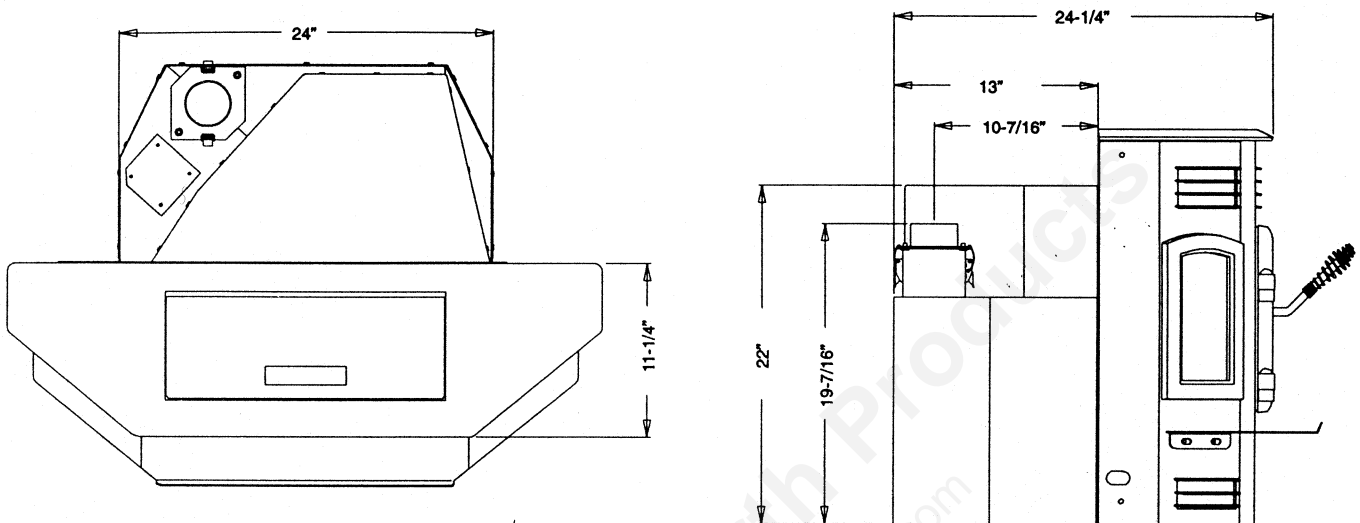

MINIMUM OPENING FOR MASONRY AND ZERO CLEARANCE

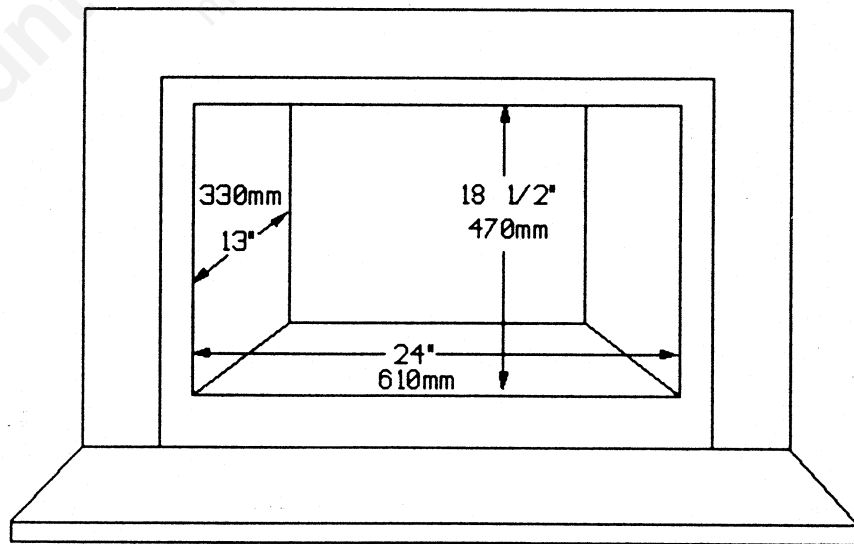

LISTINGS AND SPECIFICATIONS

QUADRA-FIRE 1100-I pellet inserts are safety tested and listed with Warnock Hersey International to UL 1482, ULC S627, APFI, and Oregon Administrative rules 814-23-900 through 814-23-909.

INSTALLATION

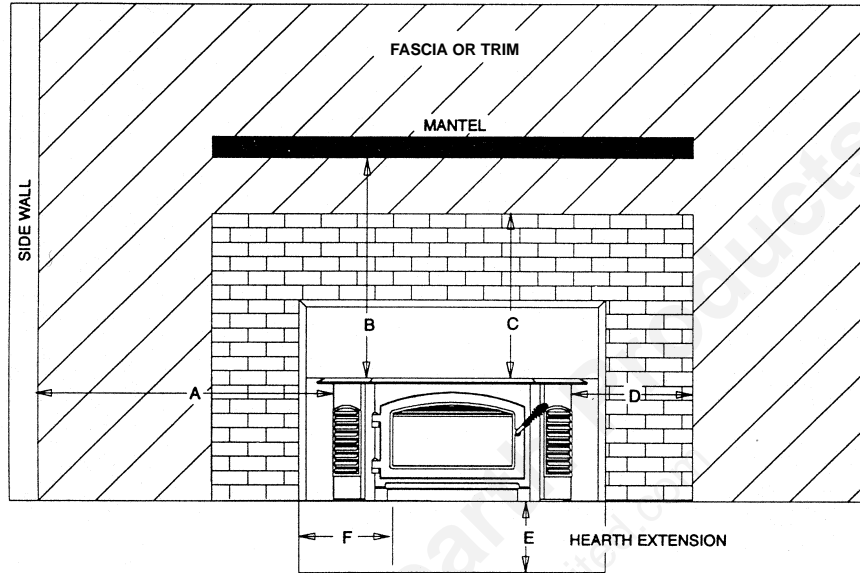

MASONRY AND ZERO CLEARANCE

A	Insert side to combustible	2" (50mm)	
B	Insert top to mantel	9" (230mm)	
C	Insert top to face trim	0" (0mm)	
D	Insert side to face trim	0" (0mm)	
E	Floor protection/hearth extension	6" (150mm)	Noncombustible material such as brick, tile, etc.
F	Floor protection to the side of door	8" (200mm)	

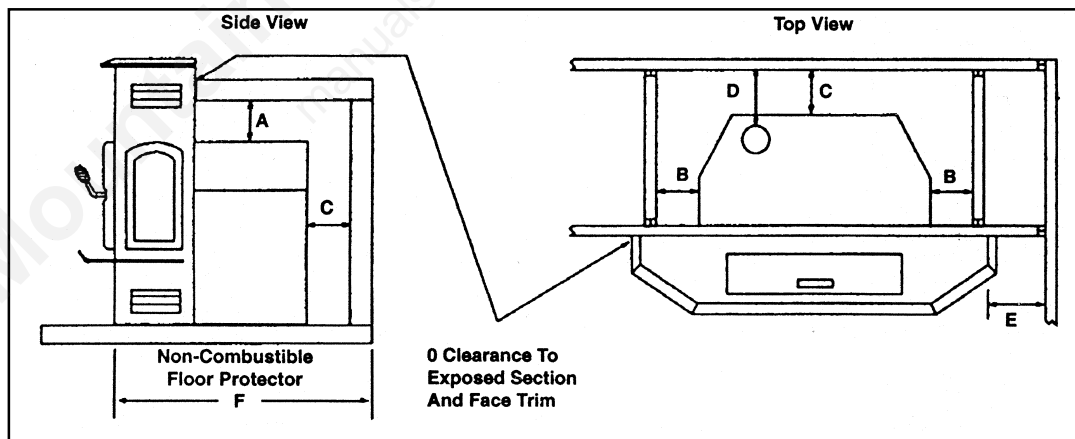

MINIMUM CLEARANCES TO COMBUSTIBLE MATERIALS WHEN INSTALLED AS A BUILT-IN

A	Top of inside shroud	2" (50mm)
B	Sides of inside shroud	2" (50mm)
C	Back of inside shroud	2" (50mm)
D	Vent pipe to combustible	3" (75mm)
E	Insert side to combustible	2" (50mm)

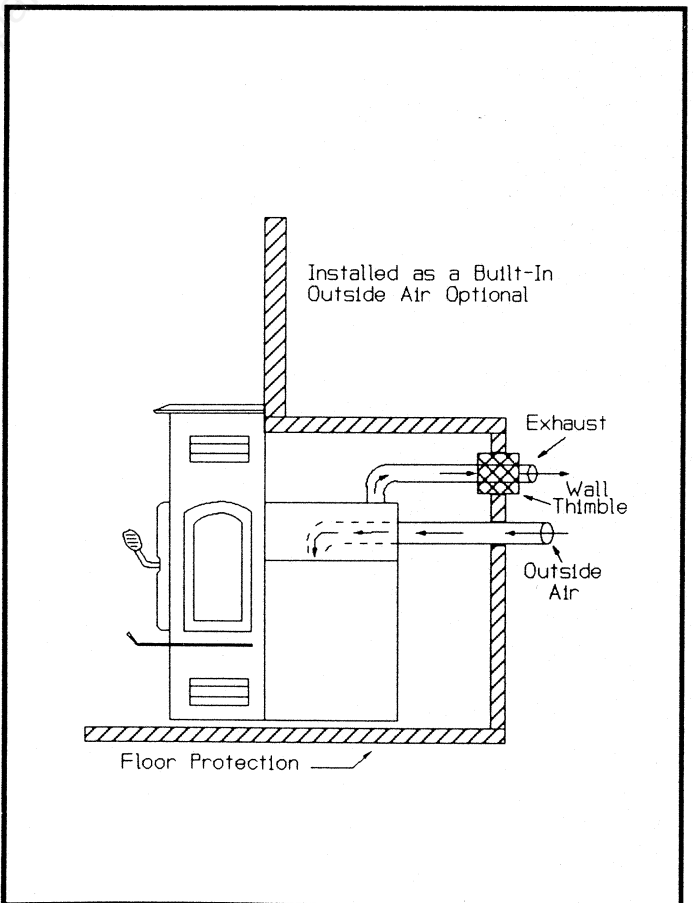
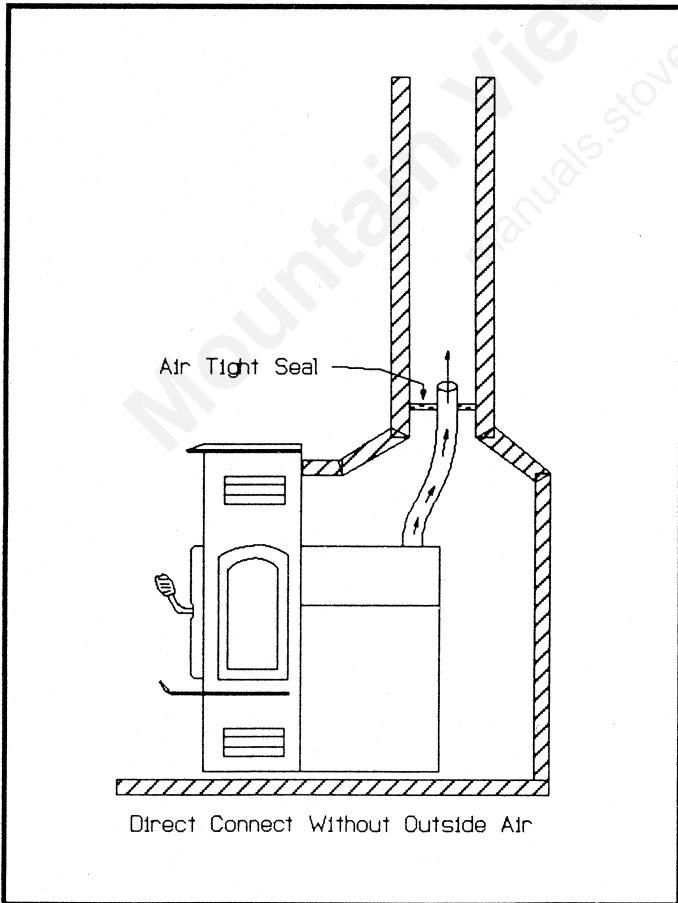
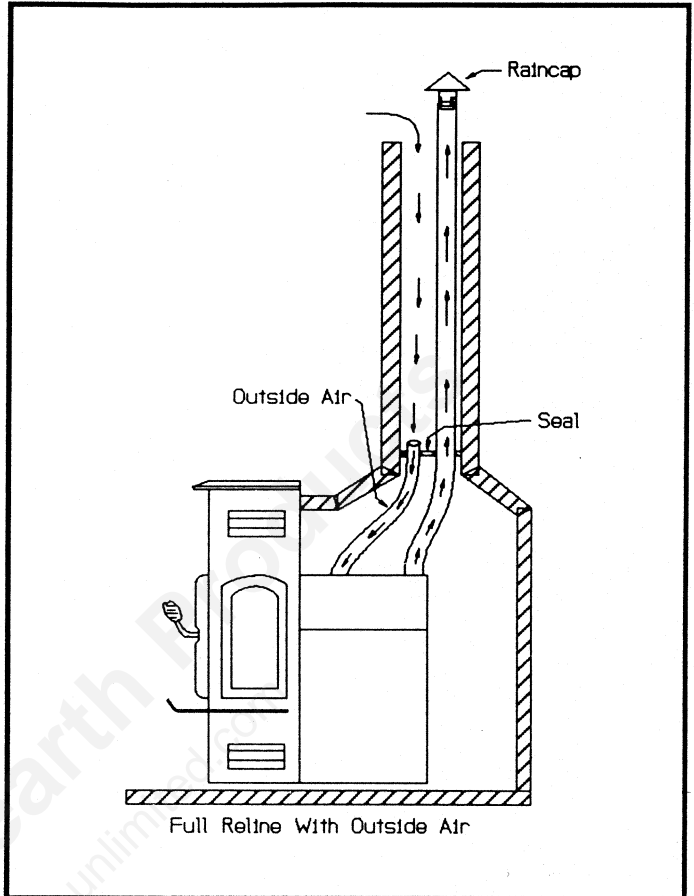
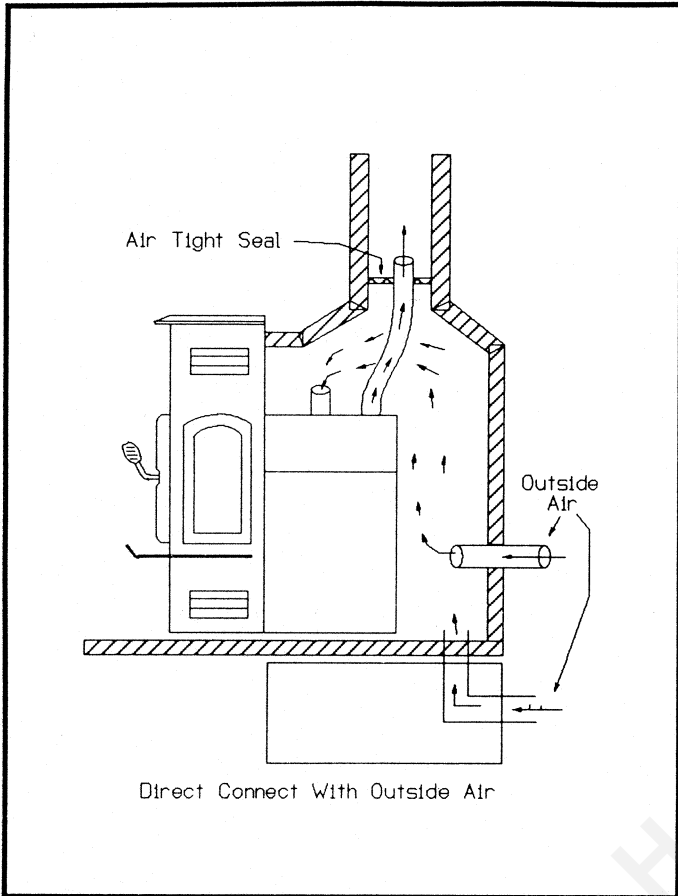

FLOOR PROTECTION

This unit may be installed on combustible flooring, providing there is 1 1/2" (37mm) of air space from the base to combustible floor, or it is placed on nominal 4" (100mm) hollow concrete blocks or any insulating material with a minimum R value of 2.5.

CHIMNEY AND EXHAUST CONNECTIONS

1. CHIMNEY AND CONNECTOR: Use 3" (75mm) or 4" (100mm) diameter listed "L" or "PL" venting systems. The insert can be either vertically or horizontally vented.
2. FIREPLACE INSTALLATION: Stainless steel rigid or flexible pipe.
3. AS A BUILT-IN: Use double-wall pipe with a stainless steel inner liner.

NOTE: All pipes are recommended to be sealed with high temperature RTV silicone.

NOTE: DO NOT INSTALL A FLUE DAMPER IN THE EXHAUST VENT OF THIS INSERT.

When installing the insert as a built-in, the insert is approved for horizontal exhaust. However, we recommend that the exhaust be installed vertically for at least eight feet, or above the eaves of the house. This will help draw smoke out of the insert in the event of a power failure.

MOBILE HOME INSTALLATION

1. An outside air inlet must be provided for combustion air, and be unrestricted while the insert is in use.
2. The combustion air duct system must be made of metal, permit zero clearance to combustible construction, prevent material from dropping into the inlet or into the area beneath the dwelling, and contain a rodent screen.
3. The insert is to be secured to the mobile home. You may drill a hole through the outer panel and secure it to the wall with a 1/4" x 2" lag bolt or equivalent.
4. Do not install the insert in a sleeping room.
5. The structural integrity of the mobile home floor, walls, and ceiling/roof must be maintained.
6. This insert is to be grounded with #8 copper grounding wire or equivalent, terminated at each end with an N.E.C. approved grounding device.
7. Refer to clearance to combustibles section (page 6) for measurements to combustibles, and appropriate chimney and venting systems for your application.

VENT TERMINATION REQUIREMENTS

1. Do not terminate vent in an enclosed or semi-enclosed area such as a carport, garage, attic, crawl space, under a sundeck or porch, narrow walkway or closely fenced area, or any location that can build up a concentration of fumes such as a stairwell, covered breezeway, etc.
2. Vent surfaces can get hot enough to cause burns if touched. Noncombustible shielding or guards may be required.
3. Termination must exhaust above air inlet elevation. It is recommended that at least five feet of vertical pipe be installed when the appliance is vented directly through a wall to create some natural draft, to prevent the possibility of smoke or odor during appliance shutdown, and to keep exhaust from causing a nuisance or hazard by exposing people or shrubs to high temperatures. In any case, the safest and preferred venting method is to extend the vent through the roof.
4. Distance from doors and windows, or gravity or ventilation air inlet into building:
 - a) Not less than 4' (1.2m) below;
 - b) Not less than 4' (1.2m) horizontally from;
 - c) Not less than 1' (305mm) above.
5. Distance from bottom of termination and grade - 12" (305mm) minimum. This is conditional upon the plants and nature of grade surface. The grade surface must not be a lawn. Distance from bottom of termination to public walkway - 7' (2.1m) minimum.
6. Distance to combustible materials - 2' (510mm) minimum. This includes adjacent buildings, fences, protruding parts of the structure, roof overhang, plants and shrubs, etc.

POWER SUPPLY

1. The power can be connected from either the left or right side of the insert. First determine which side is closest to an electrical outlet.
 - a) For power from the left, remove the left side panel and locate the power inlet (about 4" [100mm] up from the floor of the insert (refer to drawings below)). Remove the cover plate and discard, plug the power supply cord in and reinstall panel.
 - b) For power from the right, remove the right side panel. The power inlet is on the right side of the junction box, directly under the thermostat call light and the reset button. Remove the cover plate and discard, plug the power supply cord in, then be sure that you have connected the thermostat before reinstalling the side panel.

NOTE: Never install the power cord under the insert body or around sharp corners, and always maintain the power cord's integrity.

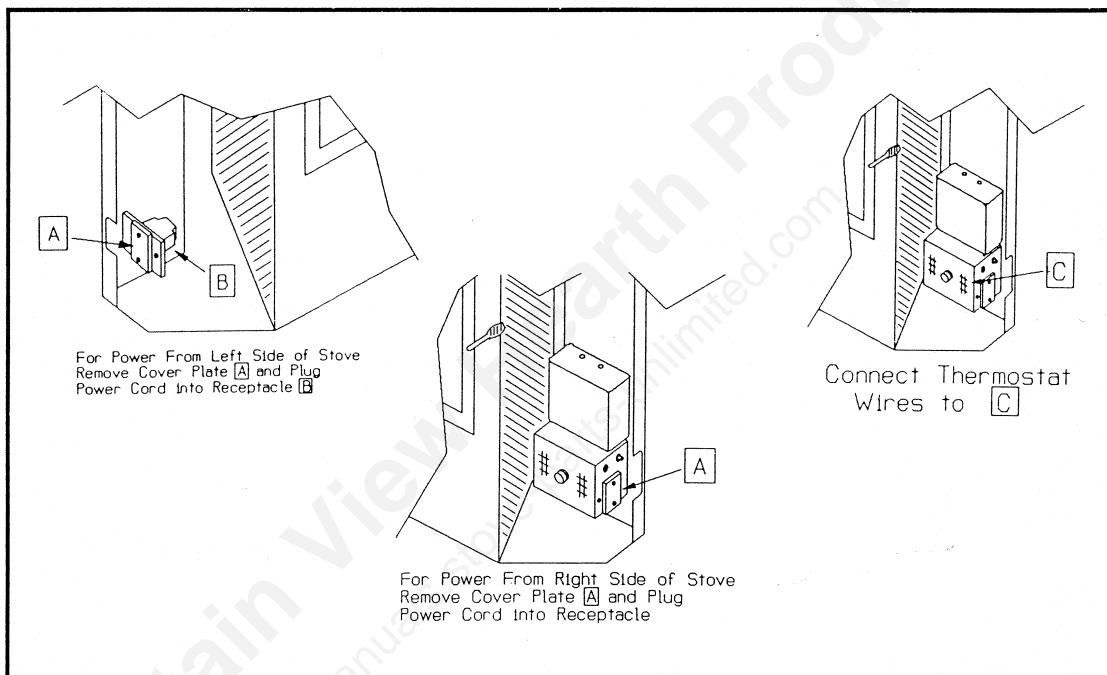

THERMOSTAT INSTALLATION

1. A 24-volt thermostat is required to operate this pellet insert. Some thermostats are equipped with an adjustable heat anticipator. The amperage draw on this insert is .05 amps, so generally the lowest anticipator setting will work.
2. When mounting the thermostat on a wall, be sure to follow your thermostat installation instructions carefully. The thermostat should be mounted on an inside wall and not in direct line with the insert's convection air outlet.

NOTE: Be sure the thermostat is mounted level for accurate readings. If the thermostat is located too close to the insert, you may need to set the temperature setting slightly higher to maintain the desired temperature in your home.
3. To connect the thermostat wiring to the insert, you must first remove the right side panel using the 5/32 hex head wrench provided, and remove the flush mounted screws on the far right side of the insert. The panel can now be lifted out of the way.
4. There is a four screw terminal block located on the right hand side of the junction box, between the fuse receptacle and the power cord inlet. The top and bottom screws are the mounting screws for the terminal block. The center two screws are for the thermostat wires. Attach the red wire to the second screw from the top of the terminal block and the white wire to the third screw from the top.

VENTING GRAPH

When running vertically with pellet venting, the following chart can be used to determine whether to use 3" or 4" (76mm or 100mm) diameter pipe.

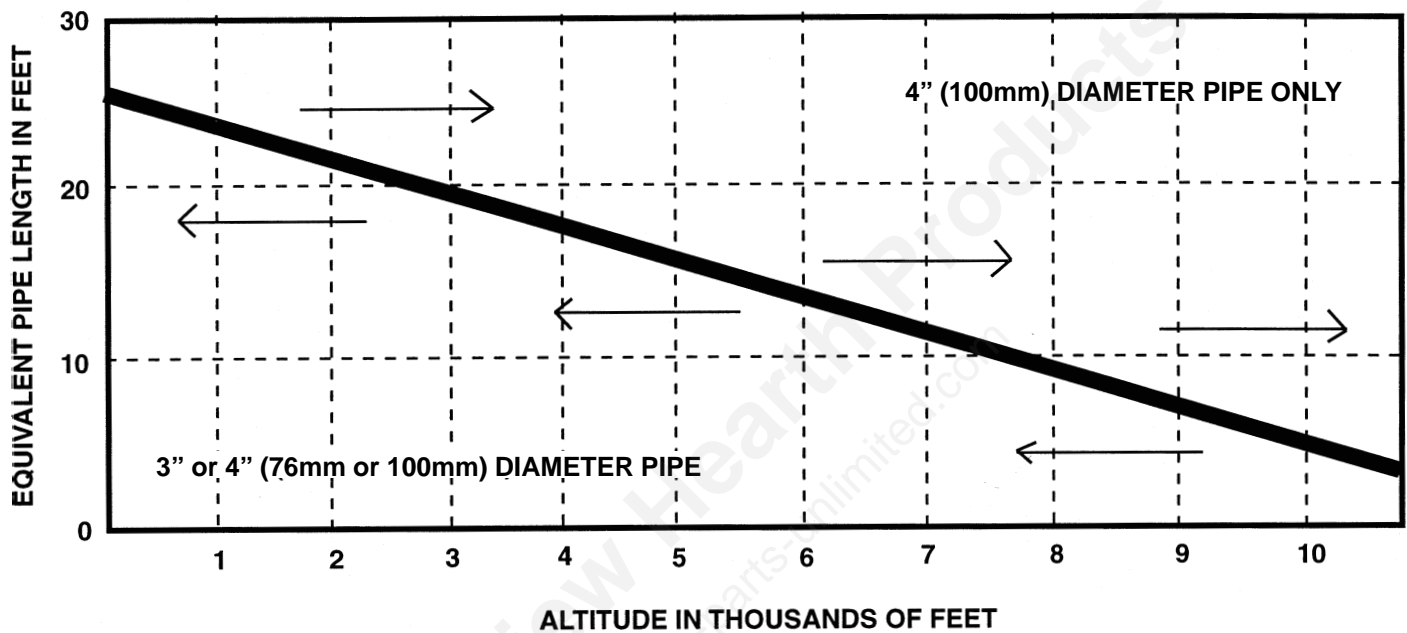

The table below can help you determine the equivalent feet of pipe used for venting when installing a pellet appliance.

Pellet Venting Component	# of Elbows or Feet of Pipe	Multiplied By:	Equivalent Feet	Component Equivalent Feet
90° Elbow or Tee		X	5	
45° Elbow		X	3	
Horizontal Pipe		X	1	
Vertical Pipe		X	.5	
TOTAL EQUIVALENT FEET				

FEED ADJUSTMENT INSTRUCTIONS

- 1) Remove any fuel in the hopper.
- 2) Loosen set screw.
- 3) Loosen wing nut.
- 4) Adjust the fuel feed by pulling the rod back to increase the feed, and sliding it forward to decrease the feed.
- 5) Tighten the set screw and the wing nut.

NOTE: Adjust fuel after the convection blower has been operating for 5 minutes. The flames should be 4" to 6" (100mm to 152mm) above the firepot after adjustment.

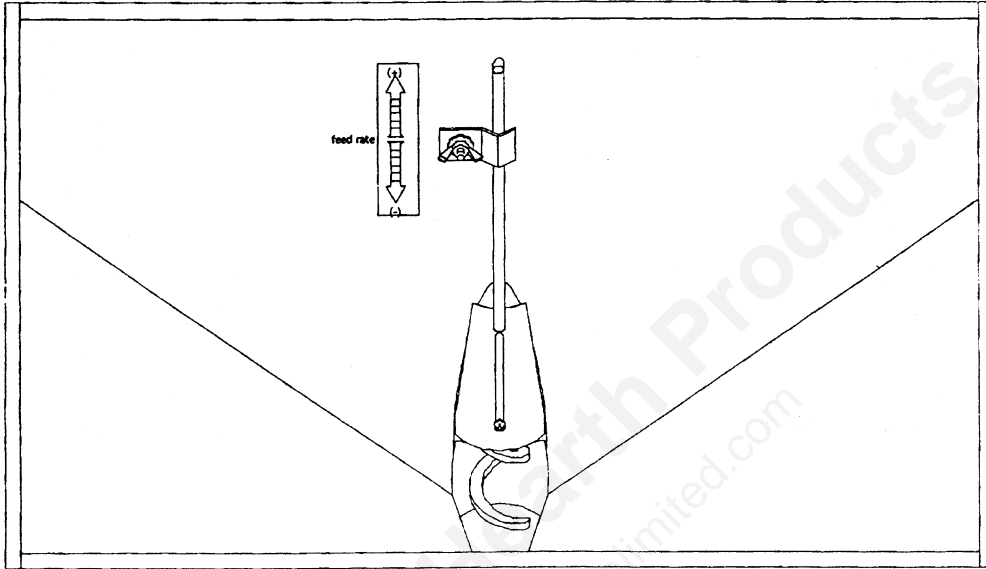

OUTSIDE AIR KIT INSTALLATION INSTRUCTIONS

1100-I

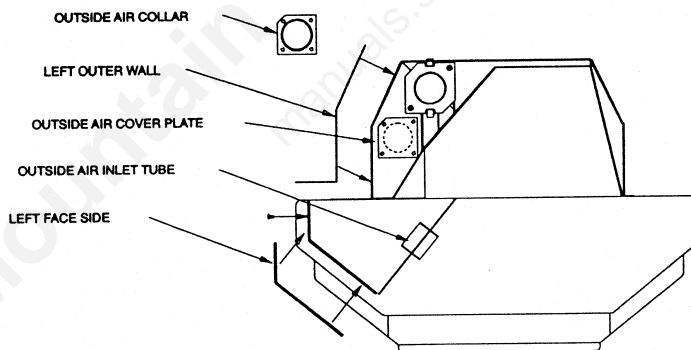

PARTS INCLUDED:

- (1) OUTSIDE AIR COLLAR
- (1) 3" FLEX PIPE, 22" LONG
- (2) 3" HOSE CLAMPS

TOOLS NEEDED:

- PHILLIPS SCREWDRIVER
- LARGE FLAT BLADE SCREWDRIVER

1. REMOVE LEFT OUTER WALL.
2. REMOVE LEFT FACE SIDE. (USE "T" HANDLE ALLEN WRENCH PROVIDED WITH STOVE)
3. REMOVE OUTSIDE AIR COVER PLATE.
4. INSTALL OUTSIDE AIR COLLAR IN PLACE OF COVER PLATE.
5. ATTACH FLEX TUBE TO BOTTOM SIDE OF COLLAR.
6. ATTACH THE OTHER END OF FLEX TUBE TO OUTSIDE AIR INLET TUBE.

NOTE: BE SURE FLEX TUBE DOES NOT TOUCH ANY MOVING PARTS INSIDE OF STOVE. A LITTLE TWIST BEFORE TIGHTENING HOSE CLAMP WILL POSITION TUBE.

7. REPLACE FACE SIDES AND LEFT OUTER WALL.

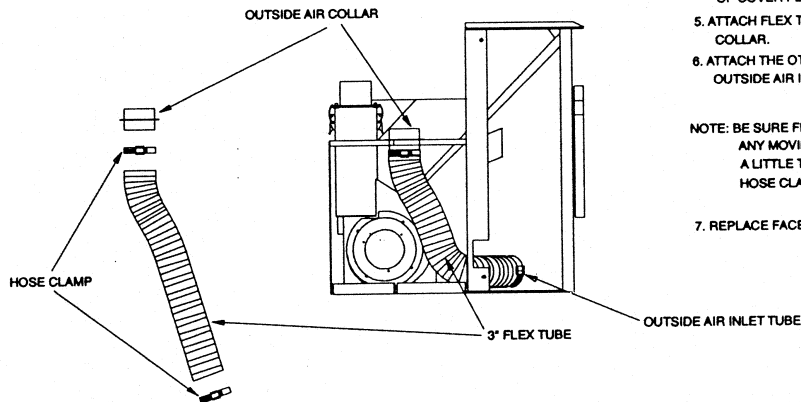

OPERATING INSTRUCTIONS

1. FUEL SIZE AND MATERIAL

Fuel pellets are made from sawdust or wood by-products. If the source material is hardwood, pellets will have a higher mineral content, creating a heavier ash. Minerals and other noncombustible materials, such as sand, will turn into glass when heated to the extreme temperatures our firepot reaches. This is what forms clinkers in the bottom of the firepot. Trees from different areas will vary in mineral content. That is why some fuels produce more clinkers than others. Pellets are manufactured in either 1/4" (6mm) or 5/16" (8mm) diameter and many varying lengths. Pellet lengths may even vary by lot from the same manufacturer, which is why the feed rate may need to be adjusted occasionally. We recommend that you buy fuel in multiton lots whenever possible. Buying large quantities of fuel at once will greatly reduce the number of times the feed adjustments will need to be made. However, we do recommend trying various brands before purchasing multiton lots, to ensure customer satisfaction.

NOTE: This insert will operate properly with either 1/4" (6mm) or 5/16" (8mm) diameter pellets. However, pellets exceeding 1 1/4" (32mm) in length can cause missed ignitions.

2. BEFORE YOUR FIRST FIRE.

- a. First, make sure your insert has been properly installed and that all safety requirements have been met. Pay particular attention to the fire protection, venting and thermostat installation instructions.
- b. Now open the front door of the insert and remove all of the accessories that were placed there for shipment. **Remove all labels that are affixed to the glass.**
- c. Check the position of the thermocouple and make sure that it protrudes approximately 1" (25mm) into the firepot. It may be necessary to slide the thermocouple and protection tube into their proper positions. Now close the front door.
NOTE: Thermocouple cover tip must be touching thermocouple tip.
- d. You are now ready to load fuel, but first see that all accessories have been removed from the hopper. Now fill the hopper with pellets.
- e. Remember that a working thermostat is required for proper operation of this insert. At this time, set the thermostat to its lowest setting.

3. START YOUR FIRST FIRE

- a. Now plug the insert in. The combustion blower will come on. Even though the thermostat is not calling for heat, the combustion blower will stay on for approximately 10 minutes. This is normal.
- b. Next, adjust the thermostat to its highest setting. The red light next to the reset button on the left side of the insert will come on. This will indicate that the thermostat is calling for heat.
- c. The fuel feed system and the igniter are now turned on. **NOTE: The fuel feed system will not run when the front door is open, or with the combustion blower operating.**
- d. For your first fire, it will be necessary to press the reset button until pellets are dropping into the firepot. This will fill the feed system and allow the insert to light.
- e. The insert will now continue to run as long as the thermostat is calling for heat. Once the insert has ignited, let it burn for approximately 15 minutes, then set the thermostat to the desired room temperature.

4. GENERAL OPERATION INFORMATION

- a. Understand that the insert is like most modern furnaces in that it has only one burn rate, full on. When the thermostat calls for heat, your insert will automatically light and deliver heat in the most efficient and economical way.
- b. Once all of the start-up procedures have been completed, simply set the thermostat to a comfortable setting and enjoy the insert. But remember, you will have to add pellets. The thermostat's location will have some effect on the insert's operation. When the thermostat is located close to the insert, it may require a slightly higher temperature setting to keep the rest of the house comfortable. If the thermostat location is upstairs while the insert is downstairs, you will notice higher temperatures near the insert.
- c. During each ignition cycle, it is normal to see some smoke. The smoke will stop once the fire starts.
- d. After your insert has been burning for approximately 15 minutes, the convection blowers will automatically turn on. These blowers transfer heat from your insert into the room, and will continue to run after the thermostat has stopped calling for heat or until all of the heat has been extracted from the insert.
- e. Occasionally, the insert may run out of fuel and shut itself down. If this happens, the red light will be on. To restart the insert, fill the hopper and press the reset button next to the light. When you press the reset button the red light will go out, and when the button is released the light will come back on. You should see a fire in about four minutes. If not, press the reset button again.

CLEANING AND MAINTENANCE

NOTE: Unplug the insert before performing any cleaning or maintenance

1. FIREPOT

A. It takes very little time to clean the firepot. We recommend that you clean the firepot at least once a week. However, if the fuel you are burning has a high dirt content, it will be necessary to clean the firepot more often. Dirty fuel will cause clinkers to form in the firepot. A clinker is formed when dirt or a nonburnable substance is heated to 2000°F (1093°C) and becomes glass-like.

B. To clean the firepot:

1. Wait for insert to be in complete shutdown (exhaust blower off).
2. Pull firepot cleanout rod out, then ride back into the closed position.
3. Open firepot access door and empty ash tray.

NOTE: Do not allow cleanout rod to slam back into closed position. This may damage igniter.

NOTE: NEVER pull rod when insert is operating.

2. FIREBOX ASH REMOVAL

Clean as needed. Make sure there are no hot ashes in the firebox before cleaning. When the insert is cool, remove ash with a vacuum or small scraper, and place it in a metal or noncombustible container.

NOTE: Embers remain hot for many days. Store container in a safe place away from combustibles.

3. HEAT EXCHANGER MAINTENANCE AND CLEANING

There is one cast finned heat exchanger in this insert. We recommend that this heat exchanger be cleaned at least once for every ton of fuel burned. **BEFORE CLEANING THE HEAT EXCHANGER, THE INSERT MUST BE COLD TO THE TOUCH AND THE POWER MUST BE DISCONNECTED.** The heat exchanger is located on the right side of the insert. To clean the heat exchanger, open the main door and remove the stainless steel cover. It has one tab at the rear of the cover. The cover must be lifted approximately 1/2" (13mm) and pulled away from the heat exchanger. Now open the bottom access door. On the right side of the firepot, there is a metal cover plate with two screws. Turn both screws counterclockwise, until they stop. Then remove cover plate by grasping the front edge and pulling out. Clean the heat exchanger with a brush or scraper, and vacuum out the ashes through the lower access hole. Then reinstall the bottom cover plate by sliding it back into place and turning the two screws in a clockwise direction until tight. Close bottom access door. Reinstall the stainless steel cover inside the firebox and close the main door. Reconnect power and readjust thermostat to desired temperature.

4. VENTING SYSTEM

The venting system should be inspected and cleaned at least once a year, or more often depending upon the quality of your fuel. If you are experiencing nuisance shutdowns, check for a clogged exhaust system. If the exhaust is restricted, the vacuum safety switch will shut the feed motor off (the red light will remain on). You can clean the venting system without removing it from the insert by opening the small hinged access door, located on top of the exhaust blower housing. Using a small vacuum attachment, vacuum the exhaust housing.

5. DOOR HANDLE ADJUSTMENT

The door latch is adjusted by removing the nut on the back of the door latch. Remove the latch cam and square key, and add or subtract a washer to space the cam as needed.

6. BLOWERS

There are three blowers in this insert: an exhaust blower that evacuates the exhaust out of the firebox, and two convection air blowers that delivers heat into the room. **THESE BLOWERS REQUIRE NO LUBRICATION.**

- A. The exhaust blower is located at the left rear side of the insert. It should be inspected during the annual cleaning of the exhaust system. The exhaust blower impellers can be inspected periodically by using the exhaust blower cleanout door.
- B. The larger convection blower is located on the front left side of the insert, and is accessible by removing the front left panel. The impeller on this blower should be cleaned at least once a year. You can do this without removing the blower. Simply brush and vacuum the impeller area.
- C. The small convection blower is located at the rear right side of the insert. When the insert is pulled out onto the hearth, it is accessible through a removable access panel. The impeller on this blower should also be cleaned at least once a year, and can also be cleaned in place.

7. DOOR GLASS CLEANING AND REPLACEMENT

- A. Be sure the insert is cold before cleaning the glass. To clean the glass, use a damp paper towel or any non-abrasive glass cleaner. Then use a dry towel to wipe off any streaks that may remain.
- B. This glass is 5/16" thick high temperature heat resistant ceramic glass. DO NOT replace it with any other material.
- C. Never slam the door or strike the glass in any way, as this may cause breakage. **NOTE: The insert will not operate with broken or missing glass. If it becomes necessary to replace the glass, replacement glass is available from your nearest Quadra-Fire dealer.**
- D. To replace glass:
 1. Remove door from insert and lay on a padded flat surface.
 2. Remove glass tabs and screws with a Phillips screwdriver by turning screws clockwise.
 3. Lift glass frame and glass out of the door frame.
 4. Place new glass with fiberglass tape around it into door frame, making sure the Quadra-Fire logo reads correctly to the outside.
 5. Place glass frame pieces over the fiberglass tape on the edges of the glass. Be sure glass is centered in the opening (i.e., same space top and bottom, left and right).
 6. Reinstall screws and glass tabs tightly enough to hold everything in place.
 7. Check again for centering of glass in door frame, and tighten all screws securely.

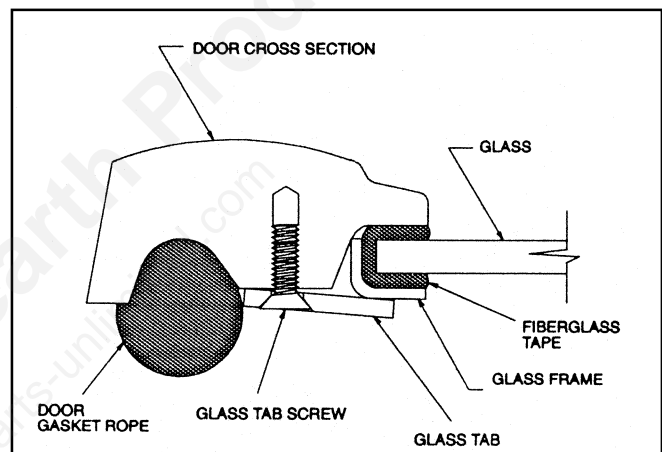
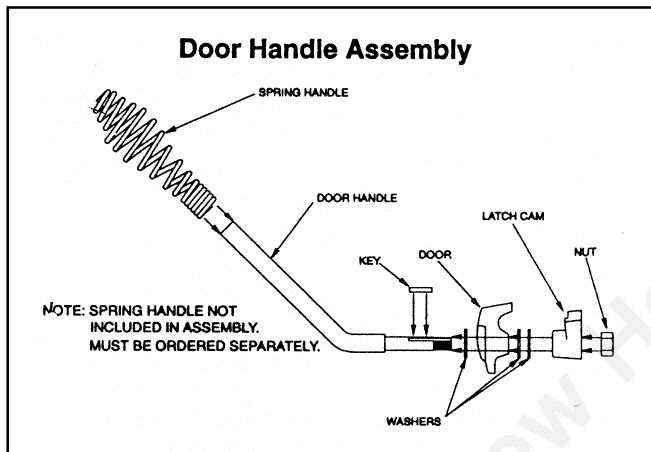

8. READING THE FIRE AND ADJUSTMENT PROCEDURES

A properly adjusted fire has a short active flame pattern that extends out of the firepot 4" to 6" (100mm to 152mm). If the fire has tall flames with black tails and seems somewhat lazy, the feed rate will need to be reduced. Start adjusting this type of fire by sliding the feed adjustment plate down about 1/2" (13mm). Within eight minutes your adjustment will have taken effect. If the fire is still too tall, lower the feed adjustment plate again. If the fire is still lazy and you have reached the end of adjustment for the feed plate, you will need to increase the combustion air. When the fire is too small and rarely peaks above the top of the firepot, you will need to increase the feed rate by adjusting the plate upwards. If the feed adjustment plate reaches the end of its travel and the fire is still low and very active, you will have to close the air adjustment to achieve a proper flame.

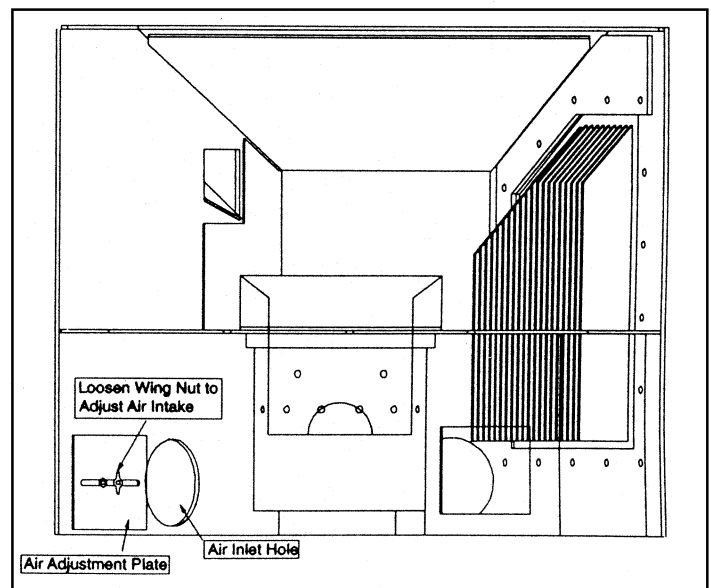
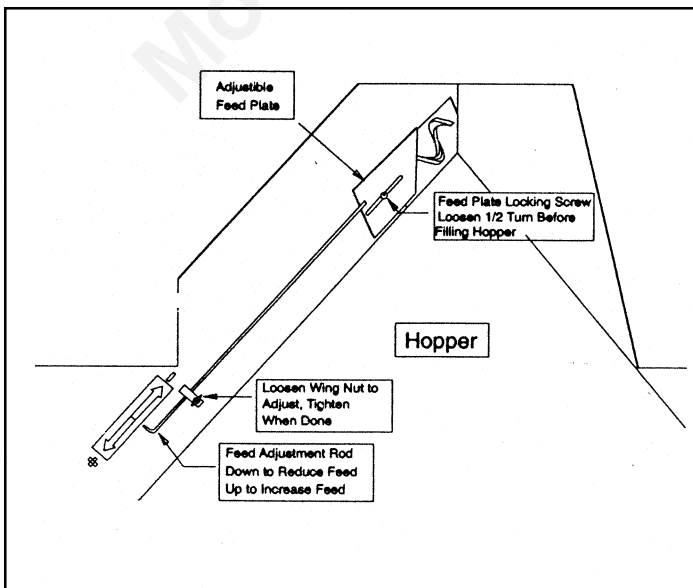

COMPONENT INFORMATION

1. POWER SUPPLY

Check the wall receptacle for 120 volt, 60 Hz (standard current). Make sure the outlet is grounded and has the correct polarity. When operating with a generator, be sure you have at least 700 watts of power available for the insert during the start cycle.

2. FUSE

The fuse is located on the right side of the insert, next to the power cord. To inspect the fuse, push the fuse holder in and turn the holder cap counterclockwise, then pull out. Replace with a standard 7 amp 120 volt fuse, if necessary. If the fuse continues to blow, contact your local dealer.

3. LIGHT

- A. The function of the light is to indicate that the thermostat is calling for heat.
- B. If the thermostat is calling for heat, the insert is burning, and the light is not on, check the bulb. Replace with a 28 volt AC (#85 lamp) bulb.

4. RESET BUTTON

- A. The function of the reset button is to momentarily open the thermostat circuit, which restarts the system. However, this will only work when the thermostat is calling for heat and the red light is on.
- B. If the light is on, there is no fire, and there is fuel in the firepot, push the reset button and wait for ignition. You should have a fire within five minutes.
- C. If the light does not go out when the reset button is pushed, the button switch may be faulty. Contact your local dealer.

5. VACUUM SWITCH

- A. The vacuum switch is located on the left side of the insert, adjacent to the feed motor. To access, you must remove the left side panel. This switch turns the feed system on when vacuum is present in the firebox.
- B. If the exhaust or the heat exchanger system is dirty or plugged, the vacuum switch will keep the feed system from starting.
- C. If the firebox door is open, the vacuum switch will keep the feed system from starting.

6. THERMOSTAT

The insert is designed to operate on a 24 volt AC thermostat. Remove the front cover and check to see that the contact points are not stuck in either the open or closed position, and that both wires are properly connected to the thermostat.

NOTE: The anticipator should be set on the lowest setting available. Also, check the wire leads for loose connections.

8. CONTROL BOX (BLACK BOX)

- A. The control box contains most of the electronics that operate the insert. When the mounting bracket is removed, the control box can be lifted away from the junction box. The control box is not to be opened, as that will void its warranty. However, the control box comes with two test lights that show if the thermocouple and control box are working properly.

- B. The green light located on the top of the control box notifies you that the insert has reached a temperature of 200°F (93°C) in the firepot. If this light is not lit in the first four minutes of operation, the insert will shut down. Check the thermocouple.

- C. The red light located to the right of the green light is to indicate that the insert has reached operating temperature. If this light does not come on in the first nine minutes of start-up, the insert will shut down. The insert will not try to relight again by itself. You must manually push the reset button to restart the cycle.

- D. If you suspect a problem with the control box, disconnect the power supply from the insert, then remove the control box and take it to your nearest Quadra-Fire dealer for testing.

NOTE: Do not open the control box. This will void the warranty. Do not plug in or remove control box without first unplugging the insert.

9. THERMOCOUPLE

- A. The thermocouple is located on top of the firepot, inside the ceramic protection tube. It continually monitors the temperature of the firepot, and lets the insert know if it's operating properly. To inspect the thermocouple, slide the ceramic protection tube off of the thermocouple. The two wires should be welded at the end, and not broken.
- B. Check the terminal block screws to see if they are tight and making a good electrical connection (located on the top of the lower junction box).
- C. Upon reinstalling the ceramic cover, be sure the thermocouple is touching the inside end of the ceramic tube and that the cover is extending 1" (25mm) into the firepot.
- D. The thermocouple sends a millivolt signal to the control box to obtain the green and red lights for the preset temperatures

10. SNAP DISC #1 (CONVECTION BLOWER)

The function of this snap disc is to turn the convection blowers (heated air) on and off as needed.

11. SNAP DISC #2 (THERMOSTAT OVERRIDE)

This snap disc will bypass the thermostat and turn off the insert if an overheat condition occurs, or if the convection blower should fail to operate. The insert will go into a normal shutdown: the combustion blower will run for ten minutes, then turn off. After the insert cools, the snap disc will automatically reset itself and the insert will relight.

12. SNAP DISC #3 (BACKBURN PROTECTOR)

If, for any reason, the fire tries to burn back into the feed system or push exhaust up the feed tube, this snap disc will shut the entire system off. However, sometimes in shipping the disc will trip and shut power off to the entire insert. To reset, unplug the insert from outlet and push in the red reset button in the center of the snap disc, then plug the insert back in and try to relight it.

13. BLOWER #1 (SMALL CONVECTION BLOWER)

This blower is located on the right side of the insert. When the insert is pulled out onto the hearth, the blower is accessible through a removable access panel. This blower comes on automatically when snap disc #1 heats up. The blower's function is to deliver heat from the insert into the room.

14. BLOWER #2 (NEGATIVE DRAFT BLOWER)

This blower creates a negative pressure (vacuum) in the firebox. It extracts all of the exhaust out of the firebox and sends it into the venting system. The blower is located on the left side of the insert. When the insert is pulled out onto the hearth, the blower is accessible through a removable access panel.

15. BLOWER #3 (LARGE CONVECTION BLOWER)

This blower is located on the left side of the insert, and is accessible through the left side panel. It is the larger of the two convection blowers, and pushes air past the cast heat exchanger and into the room. This blower, along with blower #1, will come on within 10-15 minutes of ignition.

16. FEED SYSTEM

The feed system pulls pellets up the feed tube from the hopper, using a hollow auger spring, and drops them down the feed chute into the firepot. The feed rate is adjustable; for complete instructions read the fuel feed system in the cleaning and maintenance section of this manual. **NOTE: The feed motor will not operate when the front door of the insert is open.** If you are having fuel problems, check the following:

- A. Check the ramp in the firepot to see that it is free of fuel or other materials.
- B. Check the set screw on the end of the motor shaft to see that it is tight and not slipping.
- C. Check the electrical power to the motor.
- D. Check the vacuum switch hose connections.

17. IGNITER

- A. The igniter is located in the chamber at the bottom of the firepot. It is only on during the ignition cycle, and is usually on for the first two minutes and not more than four minutes.

NOTE: The element on the igniter is extremely brittle. Be very careful in handling it.

- B. Check the wire leads to the igniter for loose or bad connections (ceramic wire nuts).

NOTE: Unplug insert before checking wire nuts.

18. FIREPOT

- A. Clean the firepot (see section on cleaning and maintenance on page 13).
- B. Make sure the cleanout plate in the bottom of the firepot is pushed in all the way.
- C. Check the gasket between the firepot and the firebox bottom. A bad seal will affect the ignition time and the flame height.

19. DOOR GASKET

Check the door gasket to see that the door is completely closed and there are no air leaks. This can be done by closing the door on a piece of paper and checking that the paper is firmly held in place. You should have resistance when you try to pull the paper away.

NOTE: If no resistance is found, the door handle assembly needs to be adjusted or rope seal needs to be replaced.

20. HEAT EXCHANGER

There is one cast heat exchanger mounted on the right side of the firebox. Refer to cleaning and maintenance section in this manual for cleaning instructions (page 13).

TROUBLESHOOTING

CAUTION: UNPLUG STOVE BEFORE SERVICING

1. PLUG IN INSERT, NO RESPONSE

- A. Check the power supply for 120 volts AC.
- B. Check the fuse in the junction box (7 amp, 120 volt fuse AGC-7).
- C. Check snap disc #3 (unplug insert before checking). Push reset on snap disc #3.
- D. Control box (consult your dealer).

2. CALL LIGHT ON, NO FIRE, NO FUEL IN FIREPOT

- A. Check the hopper for fuel, sawdust or bridging of pellets in the bottom of the hopper. If the hopper is low on fuel, vacuum can be lost through the hopper.

NOTE: Sometimes there might still be fuel in the hopper. If so, continue to check the areas below.

- B. Make sure that the exhaust blower is operating.
- C. Check the venting system for obstructions that might cause restrictions, which would cause the vacuum safety switch to shut off the auger.
- D. Check the heat exchanger system for high ash content. If buildup is present, clean the heat exchanger system.
- E. Push the reset button, and try to light the insert again.

3. CALL LIGHT ON, NO FIRE, PARTIALLY-BURNED FUEL IN THE FIREPOT

- A. Clean the firepot. Check that the igniter hole is clean and the cleanout plate is tightly in place.
- B. Inspect the thermocouple and cover for the following:
 1. The cover needs to be making contact with the end of the thermocouple.
 2. The thermocouple and the cover should extend approximately 1”(25mm) into the firepot for accurate temperature reading.
 3. Push the reset button. When the thermocouple reaches 200°F (93°C) the GREEN LIGHT will come on, and at 1000°F (538°C) the RED LIGHT will come on.

NOTE: If the lights fail to come on after the fire starts, the thermocouple may be faulty.

- C. If the thermocouple appears good, the control box may be the problem (consult your dealer).

4. CALL LIGHT ON, NO FIRE, UNBURNED PELLETS IN FIREPOT

- A. Clean the firepot (possibly a bridging problem at the ignition hole, located at the bottom of the firepot).
- B. If the fire does not start, push the reset button.
- C. Check the igniter to see that it comes on. If it does not turn on, check the following:
 1. Check the connections under the firepot. (Ceramic wire nuts must be used to withstand the heat produced by the firepot.)
 2. Make sure that the igniter is properly installed in the igniter bracket. It should fit tightly, and be centered in the igniter hole.
 3. Inspect the igniter. Replace if damaged.

5. SLOW OR SMOKY START-UP

- A. Clean the firepot. Check the firepot gasket for a good seal between the firepot and the firebox floor.
- B. Check the combustion blower (make sure that it is starting when the thermostat calls for heat).
- C. Visually check the cleanliness of the firebox, the heat exchangers and the venting system.
- D. The feed rate may be too high. If necessary, adjust with the fuel adjustment rod located in the hopper.
- E. Due to elevation, the air adjusting plate may need to be adjusted to get the right air to fuel ratio.

6. STOVE RUNS FOR 10 MINUTES, THEN STOPS FEEDING FUEL

- A. Inspect the thermocouple and the cover.
 1. The cover needs to make contact with the end of the thermocouple.
 2. The thermocouple and the cover should extend approximately 1” (25mm) into the firepot.
 3. Push the reset button. The thermocouple test lights located on the control box will automatically turn on; when the thermocouple reaches 200°F (93°C) the GREEN LIGHT comes on, and at 1000°F (538°C) the RED LIGHT comes on. If they fail to turn on after the fire starts, the thermocouple may need replacement.
 4. Check the control box (consult dealer).

7. FEED SYSTEM FAILS TO START

- A. Make sure that the front door to the firebox is closed tightly.
 - B. Check to make sure that the exhaust blower is coming on and working.
 - C. Check the heat exchanger and the venting system for obstructions or heavy ash buildup.
 - D. The vacuum switch hose may be plugged.
 1. Pull the hose off and blow through it to make sure it is clear.
- NOTE: Unplug insert from power outlet first.**
- E. Downdrafts or poor venting systems that do not follow manufacturer’s recommendations can also cause this problem.
 - F. Check the hopper and the feed system for blockage.

8. THERMOSTAT WILL NOT START UNIT

- A. Check the power to the insert.
 - 1. Unplug for 10 seconds and then plug back in. The exhaust blower should come on. If it does, go to C.
- B. Check the power supply (plug should be 120 volts, fuse should be 7 amp, 120 volt [AGC-7]).
- C. The thermostat or the thermostat wiring maybe faulty.
 - 1. Disconnect the thermostat wires from the insert. Make a jumper wire in order to create a manual bypass to determine if the insert or the thermostat is faulty.
NOTE: Unplug the insert while hooking up the jumper wire. Plug the insert back in and the unit should come on and light. If the unit lights, check the thermostat and the wires connecting them.
- D. Check reset button to make sure current is passing through it.
- E. Snap disc #2 would bypass the thermostat if an overheating situation occurs. The snap disc should reset itself once it cools down.
- F. Check the control box (consult dealer).

9. UNIT FAILS TO SHUT OFF

- A. Check the thermostat and the thermostat wires.
 - 1. Remove one of the thermostat wires from the insert; the insert should go into a normal shutdown cycle.
- B. Check the control box (consult dealer).
- C. Check the junction box (consult dealer).

10. SMOKE FROM THE CONVECTION AIR OUTLET

- A. Check the exhaust blower housing and **all** venting connections.
- B. Most problems with smoke in the house are the result of a poor venting system.

11. CONVECTION BLOWERS KEEP RUNNING OR FAIL TO START

- A. Snap disc #1 may need to be replaced.
- B. Check the wire connections on snap disc #1 and the convection blowers to be sure a good connection is being made.
- C. Check the convection blowers.

12. INSERT CYCLES ON AND OFF, THERMOSTAT ALWAYS ON

- A. Check that snap disc #1 is coming on and turning the convection blowers on. If not, snap disc #2 could be bypassing the thermostat until the snap disc cools and resets itself.

13. LARGE FIRE, ASH BUILDUP AND DIRTY GLASS

- A. Clean the firepot. Check the firepot gasket for a good seal between the firepot and firebox surface.
- B. Visually check the cleanliness of the firebox, the heat exchanger and venting system.
- C. Reduce the feed rate, if necessary, to maintain a fire height of about 4" to 6" (100mm to 153mm) above the top of the firepot.
- D. If the above do not help, an air adjustment may be needed. Open more to increase air to help even the air to fuel ratio.

14. UNIT BURNING, NO CALL LIGHT

- A. Replace light bulb (#85 lamp).

15. STOVE IGNITES THEN GOES OUT, LIGHTS STILL ON = NUISANCE SHUTDOWN

- A. Inspect the thermocouple and the cover.
 - 1. Make sure that the thermocouple end and the cover make contact.
 - 2. The thermocouple and the cover should extend approximately 1" (25mm) into the firepot.
 - 3. Push the reset button. When the thermocouple reaches 200°F (93°C) the GREEN LIGHT will come on, and at 1000° F (538°C) the RED LIGHT will come on.
- B. Check the fire height. It should be 4" to 6" (100mm to 153mm) out of the firepot.
 - 1. Too high of a fire will lower the vacuum in the firebox and the vacuum switch may turn off the feed system, resulting in total shutdown or feed system shutdown until vacuum is regained.
NOTE: This may also happen in complicated venting systems, or at high altitudes. Use the feed adjustment plate to slow fuel input and reduce flame height. If this does not help, check the air adjustment plate.
 - 2. Too low of a fire will let the firepot temperature drop below 1000°F (538°C) and will turn the insert off. Increase fuel, check for sawdust and bridging of pellets.
- C. Check the heat exchanger and the venting system for buildup or restriction (cleanout ash buildup).
- D. Check the vacuum switch for proper operation.
 - 1. Make sure that the vacuum hose is not clogged.
 - 2. With normal operation, the vacuum switch should shut the feed system off when the door is opened, and restart the feed system when the door is closed again.

NOTES

Mountain View Hearth Products
manuals.stove-parts-unlimited.com



North America's Best

lifetime warranty

Aladdin Hearth Products, warrants their pellet heating appliances to the original purchaser for the lifetime of the appliance, to be free from defects in material and workmanship. This warranty gives you specific legal rights; you may have other rights which may vary from state to state.

This limited Lifetime Warranty covers items such as but not limited to combustion chambers, heat exchanger systems, stainless steel firebox components, doors, gold plating, and glass damaged by thermal breakage.

All parts to be replaced must be returned to an authorized Aladdin Hearth Products dealer at purchaser's expense for inspection and approval by Aladdin Hearth Products prior to repair or replacement. No repair or replacement costs will be honored without approval of Aladdin Hearth Products.

This new Quadra-Fire product must be installed by a competent, authorized service contractor. It must be installed and operated at all times in accordance with the installation and operating instructions contained in this manual, as well as any applicable local and national codes. Any alteration, willful abuse, accident, or misuse of the product shall void this warranty.

Any installation, construction, transportation, or other related costs or expenses arising from defective part(s), repair, replacement, etc., will not be covered by this warranty, nor will Aladdin Hearth Products assume responsibility for them. Further, Aladdin Hearth Products will not be responsible for any incidental, indirect, or consequential damages, except as provided by law.

Our E-Z Clean and ceramic firepots are both covered under Aladdin's three year warranty program.

All electrical components such as but not limited to blowers, igniters, wiring, vacuum switches, speed controls, control boxes, and thermodisc switches are covered by Aladdin's one year warranty program.

Aladdin Hearth Products, will not be responsible for any alteration to the unit which causes sooting that results in damage to the interior or exterior of the building in which this appliance is installed.

This warranty is void if the insert has been operated in atmospheres contaminated by chlorine, fluorine, or other damaging chemicals, the insert is subjected to prolonged periods of dampness or condensation, or there is any damage to the insert or other components due to water or weather damage which is the result of, but not limited to, improper chimney or venting installation.

This limited Lifetime Warranty does not extend to or include paint, pellet insert logs, door gasketing, glass gasketing, firebrick or other ceramic insulating materials. It does not cover installation or operational-related problems such as overfiring, downdrafts or spillage caused by environmental conditions, nearby trees, buildings, hilltops, mountains, inadequate venting or ventilation, excessive offsets, or negative air pressures caused by mechanical systems such as furnaces, fans, clothes dryers, etc.

This limited Lifetime Warranty does not apply to venting components, hearth components or other accessories used in conjunction with the installation of this product not manufactured by Aladdin Hearth Products. This limited Lifetime Warranty is effective on all pellet inserts sold after September 1, 1996, and supersedes any and all warranties currently in existence.

---IMPORTANT---

This warranty is not valid unless the warranty registration card has been property completed in full and returned within 10 days from the date of purchase.

FOR YOUR RECORDS:

DATE PURCHASED _____ MODEL # _____

AUTHORIZED DEALER _____ SERIAL # _____

Copyright Aladdin Hearth Products, May 1997