

TABLE OF CONTENTS

PELLET SERVICE MANUAL

MODEL 1100-I

QUICK & EASY REFERENCE GUIDE

| | <u>PAGE</u> |
|---------------------------|-------------|
| Trouble Shooting & Repair | I - V |

FUNCTION & DETAILS

| | |
|--------------------------------------|---------|
| Power Supply | 1 |
| Fuse | 2 |
| Light | 2 |
| Restart Button | 2 |
| Vacuum Switch | 2 - 3 |
| Junction Box | 3 - 5 |
| Thermostat | 5 - 6 |
| Control Box | 6 - 7 |
| Thermocouple | 7 - 8 |
| Snap Disc #1, Convection Blower | 8 |
| Snap Disc #2, Thermostat Override | 8 |
| Snap Disc #3, Back Burn Protector | 9 |
| Blower #1, Positive Draft 30 CFM | 9 |
| Blower #2, Negative Draft 80 CFM | 9 - 10 |
| Blower #3, Connection Air 160 CFM | 11 |
| Feed System | 12 - 13 |
| Igniter | 13 - 14 |
| Firepot | 14 |
| Exhaust | 15 |
| Door and Latch | 15 |
| Heat Exchangers | 15 - 17 |
| Stainless Steel Firebox Liner | 17 |
| Outside Air & Air Adjustments | 18 |
| Figure #1 (Power Supply) | 18 |
| Figure #2 (Thermostat Wiring) | 19 |
| Figure #3 (Feed Adjustment) | 19 |
| Figure #4 (Exhaust Blower Wiring) | 20 |
| Figure #5 (Left Side Power Supply) | 20 |
| Figure #6 (Heat Exchanger Cleanout) | 21 |
| Figure #7 (Air Adjustment) | 21 |
| Figure #8 thru #11 (Heat Exchanger) | 22 |
| Figure #12 thru #14 (Heat Exchanger) | 23 |
| Figure #15 thru #16 (Heat Exchanger) | 24 |
| Outside Combustion Air Instructions | 25 |

TROUBLE SHOOTING & REPAIR

A. PLUG IN STOVE -- NO RESPONSE

1. Check the power supply for 120 volts
2. Check the fuse in Junction Box
 - a. 7 amp, 120 volt fuse (AGC - 7)
3. Check Snap Disc #3 (unplug stove before checking Snap Disc #3)
 - a. Push reset button on Snap Disc #3
4. Control Box (Refer to Control Box Section)

B. CALL LIGHT ON -- NO FIRE -- NO FUEL IN FIREPOT

1. Check hopper
 - a. Stove may stop feeding while there are some pellets in hopper
2. Make sure Exhaust Blower is operating
3. Check Venting System for obstructions
4. Push Restart Button on Junction Box
5. Vacuum Switch & Vacuum Line (Refer to Vacuum Switch Section)
6. Power to Feed Motor (Refer to Feed Motor Section)

C. CALL LIGHT ON - NO FIRE- PARTIALLY BURNED FUEL IN POT

1. Check Firepot and clean
2. Inspect Thermocouple and Cover
 - a. Cover needs to make contact with end of Thermocouple
 - b. Cover should extend approx. 1" into the Firepot
 - c. Push Restart button on Junction Box.

Watch lights On the Control Box.

200° GREEN LIGHT comes On,

1,000° RED LIGHT comes On

D. LIGHT ON -- NO FIRE -- FUEL IN FIREPOT

1. Clean Firepot
2. Push Restart Button
3. Igniter (check to see if it comes on)
 - a. Wire nuts
 - b. Make sure Igniter is properly installed

E. SLOW OR SMOKEY START UP

1. Clean Firepot & check Firepot Gasket
2. Check Combustion Blower (make sure it is working)
3. Visually check cleanliness of Fire Box, Heat Exchanger and Venting
4. Feed Rate may be too high (Adjust if necessary)
5. Adjust air inlet opening

F. RUNS FOR 10 MINUTES -- THEN STOPS FEEDING FUEL

1. Inspect Thermocouple and Cover
 - a. Cover needs to make contact with end of Thermocouple
 - b. Cover should extend approx. 1" into the Firepot
 - c. Push Restart button on Junction Box.

Watch lights On the Control Box.

200° GREEN LIGHT comes On,

1,000° RED LIGHT comes On

2. Check Control Box

G. FEED SYSTEM FAILS TO START

1. Front door must be closed
2. Check Combustion Blower (make sure it is working)

3. Check Exhaust Vent for obstructions
4. Vacuum Switch and Vacuum Line
5. Feed System (Refer to Feed Motor Section)

H. THERMOSTAT WILL NOT START UNIT

1. Check power to stove
 - a. Unplug stove for 10 seconds, plug in
(COMBUSTION BLOWERS SHOULD COME ON, IF NOT... GO TO NUMBER 3)
2. Power supply
 - a. Check plug in for 120 volts
 - b. Check Fuse 7 amp, 120 volt (AGC 7)
3. Thermostat (Refer to Thermostat Section)
4. Restart button on Junction Box
5. Snap disc #2
6. Control Box

I. UNIT FAILS TO SHUT OFF

1. Check Thermostat and Wire
 - a. Disconnect Thermostat Wire, stove should shut down
2. Check Control Box
3. Check Junction Box & Wiring Harness
 - a. If you have to change Junction Box or wiring harness
to solve the problem, reinstall the original Control Box

K. CONVECTION BLOWER KEEPS RUNNING OR FAILS TO START

1. Snap Disc #1 (Refer to Page 13)
2. Convection Blower (Refer to Page 3)

M. UNIT CYCLES ON AND OFF -- THERMOSTAT ALWAYS ON

1. Snap Disc #1 (Convection Blower)
 - a. Convection Blower and Snap Disc #1 may not come on, causing Snap Disc #2 to trip
2. Snap Disc #2 (Thermostat Override)
 - a. May trip and reset automatically when stove cools

N. LARGE FIRE, ASH BUILD UP & DIRTY GLASS

1. Clean the Firepot
 - a. Check the Firepot Gasket
2. Visually check cleanliness of Fire Box, Heat Exchanger, and Venting
3. Reduce the Feed Rate if necessary
4. Adjust air on 30 CFM blower (If necessary)

O. UNIT BURNING -- NO CALL LIGHT

1. Replace Light Bulb (85 Lamp)

P. UNIT IGNITES -- GOES OUT -- LIGHT STILL ON

"NUISANCE SHUT DOWN"

Stove burns fine when you are there, and goes out after you leave

1. Inspect Thermocouple and Cover
 - a. Cover needs to make contact with end of Thermocouple
 - b. Cover should extend approx. 1" into the Firepot
 - c. Push Restart Button on Junction Box.

Watch lights on Control Box

200° GREEN LIGHT comes On,

1,000° RED LIGHT comes On

2. Check fire height (2" to 4" out of Firepot)
 - a. If fire is too high, it will lower vacuum in Firebox and Vacuum Switch may turn off Feed Motor

NOTE: THIS MAY HAPPEN WITH COMPLICATED VENTING SYSTEMS OR AT HIGH ALTITUDE

- b. If the fire is too low it will let the Firepot temperature drop below 1000° and will turn the stove off
3. Check the Exhaust for ash build up and restriction
4. Check the Vacuum Switch for proper operation

**SERVICE MANUAL
QUADRA-FIRE 1100**

February 17, 1993

This manual is designed to help you understand all of the components of the **QUADRA-FIRE 1100 Fireplace Insert**. To help you in troubleshooting our product, we have designed a Test Box along with Operating Instructions and a Troubleshooting Guide. When the Test Box is installed in the stove you have the ability to test each component individually. With the Test Box and test box manual, trouble shooting the stove is a lot easier.

1. POWER SUPPLY

Standard current of 120 volt, 60 Hz is required to operate the stove. The current draw is approximately 4.6 amps during the startup cycle which normally lasts for two minutes, but can last up to six minutes. After the first two minutes of operation during a normal start the current draw will drop to approximately 1.6 amps. For an alternative power supply, you may use a generator that produces a minimum of 700 watts of AC power.

NOTE: AMPS x volts = watts
 (4.6 AMPS x 120 v = 552 watts)

The 1100 has the ability to receive power from either side. Only remove the cover plate on the side you plan to put power to. A standard computer or printer power cord is used to supply power to the stove. If the cord supplied is not long enough, you can purchase a longer cord at a computer supply store or Radio Shack. Just be certain it's at least 18 gauge wire.

Internal Routing of Power

No matter which side the power is supplied from, the power will travel via a black wire to the main fuse located between the thermocouple terminal block and the thermostat terminal block. Power then leaves the main fuse via the light gray wire and goes to snap disc #3 located on the left side of the stove on the round feed tube. From here the power goes to snap disc #1 and the control box via the orange wire. (Refer to Figure #1 page 18 (Power Supply) When power is supplied to the stove, the orange wire will show line voltage whether the stove is running or not.

Note: When using the left side power receptacle on stoves between serial numbers 140000 & 140484. Check the black and white wire location. See Figure #4 Left Side Power Supply page 20. They may be reversed.

2. FUSE

The fuse is located on the junction box. To check the fuse, push in and turn counter clockwise, then pull out. A standard AGC 7 amp, 120 volt fuse is used. If the fuse is blown see the TEST BOX MANUAL, Page 5, Paragraph VII. For wiring information see Figure #1 Page 18.

3. LIGHT

The light is located on the right side of the junction box, it's function is to indicate that the thermostat is calling for heat. If replacement is necessary remove the lens cap by turning counter-clockwise approximately 1/16th of a turn, it will then pull straight off. To remove the light bulb, pull straight out (No turning required). The light bulb required is a 28 volt AC bulb, (#85 Lamp).

Notes _____

4. RESTART BUTTON

The restart button is located on the right side of the junction box. It's function when pushed, is to momentarily open the thermostat circuit which restarts the stove. However, this will only work when the thermostat is calling for heat and the red light is on. (Refer to Figure #2 Thermostat Wiring Page 19).

Notes _____

5. VACUUM SWITCH

This is a safety device designed to shut off the feed system if:

- (1) The front door is open
- (2) The 80 cfm negative draft blower fails
- (3) The exhaust becomes plugged by ash or any other foreign material

This switch is located on the left hand side of the stove. All of the power that goes to the feed motor passes through it. There are two wires that run to it, a red wire bringing power and a black wire that comes straight from the feed motor itself. There are two different styles of vacuum switches. The earlier style is adjustable and is smaller and mounted horizontally. It has three terminals on the vacuum switch itself, 1 vertical and 2 horizontal. The wires must connect to the one vertical (marked C) and the bottom horizontal (marked NO), order does not matter.

On later model stoves the vacuum switch has a metal housing and is mounted vertically. This style is not adjustable and has only two connectors. The red wire that comes from the harness and the black wire which comes from the feed motor can connect to either contact.

The vacuum should read approximately .23 inches of water on a cold stove with the combustion blower running and .12 inches of water on a hot burning stove. If the stove loses vacuum (front door open), the feed system will shut off. Shortly after the feed system stops, the stove will shut down. However the red indicator light will remain on.

ADJUSTMENT PROCEDURES (Early Models Only)

It may become necessary to adjust or change the vacuum switch if the feed motor fails to run or the feed motor continues to run when the front door is open. To adjust the switch first locate the adjustment screw. It is located on the bottom of the switch in the center. There is a hole punched in the mounting bracket that enables you to access this screw without removing the vacuum switch itself. The tool required is a (1/8" Allen Wrench)

If the feed motor continues to run with the front door open, turn the adjusting screw in a clock-wise direction (tighten screw) until the feed motor stops. If the feed motor fails to start and the combustion blower is running with the front door closed, turn the adjusting screw in a counter-clockwise direction (loosen screw).

After adjusting the vacuum switch test it by letting the stove run approximately 15 minutes or until it is hot. Then open the front door and see that the feed motor stops within 10 seconds. Upon closing the front door the feed motor should start within 5 seconds. If not, adjust the vacuum switch again. If it is necessary to replace the vacuum switch **Do Not over tighten** the mounting screws.

Notes _____

6. JUNCTION BOX (Wiring Harness)

The junction box is located on the right hand side of the stove and is accessible by removing the right side panel. The junction box and the wiring harness are two separate assemblies. The junction box has only one moving part (the restart button) so replacement is rare.

To change the junction box:

1. Disconnect the power from the stove.
2. Remove right side panel.

3. From the front of the junction box remove the thermostat wires from the terminal block located on the right side of the fuse then remove the thermocouple wires from the terminal block located on the left side of the fuse.
Note: The red thermocouple wire goes to the bottom center screw on the terminal block and the yellow thermocouple wire goes to the top center screw.
4. On the left side of the junction box disconnect the wiring harness see Figure #10 page 22 (Junction Box).
5. Remove the control box.
6. Loosen the screw in the upper left hand corner of the junction box and remove the screw on the right hand side of the box. The junction box will now slide out.

Instructions to change a wiring harness:

1. Disconnect power from stove.
2. Remove both right and left side panels and open the firepot access door.
3. On the left hand side of the stove, disconnect the red wire that goes to the vacuum switch and the white wire that goes to the feed motor.
4. Remove the rubber boot from the top of each capacitor. Disconnect the blue wire from the capacitor marked 3uf.
Note: The blue wire and the black wire are on the same side of the capacitor and the brown wire is by itself on the opposite side. See Figure #4 Page 20.
5. Disconnect the purple wire from the capacitor marked 4uf.
Note: The purple wire and the black wire are on the same side of the capacitor and the brown wire is by itself on the opposite side. See Figure #1 Page 18.
6. Disconnect the two sets of white wires that come from the harness and connect to the blue wires coming from both blowers.
7. On the lower left power inlet disconnect the white and black wires and remove the green wire from the wiring loom and leave it in place.

Note: when reconnecting the white and black wires refer to Figure #5 page 20 (Left Side Power Supply).

8. Remove the orange and gray wire from the snap disc located on the round feed tube.

Note: Position of wires on the snap disc does not matter. See Figure #1 Page 18.

9. Now through the front firepot access door remove both wire nuts from the igniter wires.

Note: Rotating the pot will make this easier to do.

10. Through the right side panel, reach back to the small convection blower and disconnect the purple and white wires from it. See Figure #1 Page 18.

11. Unplug the wiring harness from the junction box as per Figure #10 page 22.

12. The wiring loom is tied with several plastic wire ties to the stove body. Cut all of these wire ties and then remove the loom from the stove.

13. Reinstall in reverse order.

Note: It is important to secure the wiring loom with the wire ties supplied to prevent it's contact with hot surfaces.

Notes _____

7. THERMOSTAT

The stove is designed to run on a 24 volt AC thermostat. We recommend that you use a new thermostat when installing this stove. The function of the thermostat is to turn the stove ON when heat is required. If the stove does not start and the red light does not come on in the lower right hand corner of the stove. Refer to the TEST BOX OPERATING INSTRUCTIONS and use the test box for easy trouble shooting procedures. If a test box is not available, follow the directions below:

1. Disconnect the thermostat wires from the thermostat terminal block located on the junction box behind the right side panel. Jump the thermostat screws (THE TWO MIDDLE SCREWS Refer to Figure #2 Page 19) with a short piece of wire. If the red light comes ON and the stove starts, the thermostat or thermostat wiring is faulty.
2. If the red light does not come ON, and the stove starts with the jumper wire installed, the indicator light may be faulty.

3. If the stove does not come ON with the jumper wire installed unplug the stove and after 10 seconds plug the stove back in. The combustion blower should come on. If the blower comes on the problem may be in the thermostat wiring loop. Refer to Figure #2 Thermostat Wiring Page 19.
4. If the combustion blower does not come on after reconnecting the stove to power, Refer to Section 8, CONTROL BOX.
5. Be sure the Control Box is plugged in.

Note: Some thermostats are equipped with an adjustable heat anticipator and should be adjusted to match the electrical current rating of the stove. The current rating of our stove is .05 amps. Generally the lowest anticipator setting will work. Also certain thermostats require 24 volt AC power to operate. That power is provided from the stove. The bottom center screw of the thermostat terminal block is the hot terminal and supplies 24 volts of AC power. The top center screw is the grounded terminal. If the thermostat fails to work, be sure to check that the red wire is connected to the proper terminal on both the thermostat and the stove. See Figure #2 Page 19.

Notes _____

8. CONTROL BOX (Black Box)

The control box houses the electronics which controls all functions of the stove, except for the convection blowers which are controlled by snap disc #1. The control box is equipped with two tiny indicator lights located on the top of the box. See Figure #9 Page 22.

GREEN LIGHT located on the top left: Indicates that the stove has reached a low temperature of 200°F at the end of the thermocouple in the firepot.

RED LIGHT located on the top right: Indicates that the thermocouple has reached the stove's operating temperature of 1000°F.

To see if power is getting to the control box, unplug the power cord and after 10 seconds plug it back in. The combustion blower should start up and run for approximately 7 minutes. If the blower fails to turn on check the following:

1. Check the wall outlet for power.

2. Check for a blown fuse on the front of the junction box.

3. **Disconnect power** and press the reset button on snap disc #3 located on the left side of the stove on the round feed tube and then reconnect power.

If none of the above have started the stove, the fuse may be blown in the control box. To inspect the fuse remove the four screws from the bottom of the control box and remove the top cover. Check the fuse, and if it is blown, replace it with a 5 x 20 mm 1/2 amp fuse. Replace the top cover and reinstall the control box in the stove. If the fuse continues to blow, then change the control box.

Notes _____

9. THERMOCOUPLE

The thermocouple is made up of two dissimilar metals that when joined together produce a small amount of electricity which increases with temperature. There are many types of thermocouples. The type used in this stove is a "K" type. The thermocouple is covered by a ceramic protection tube and should protrude approximately 1" into the firepot from the right hand side. The function of the thermocouple is to sense the temperature in the firepot. If the thermocouple is broken, the red and green lights on the control box will not come on. See Figure #9 Page 22.

If the green light located on the control box fails to come on after ignition or the red light fails to come on after approximately 9 minutes of operation, the thermocouple is probably broken. If this is the case, follow directions below:

1. Remove the ceramic protection tube which covers the end of the thermocouple.
2. Check the two wires that protrude out of the protective sheathing for a broken or poor connection. Should connection be bad or broken, replace it with a new thermocouple or temporarily repair the old one. To repair a broken thermocouple, follow these directions:
 - (A) Cut off approximately 1-1/2" from the end of the thermocouple.
 - (B) Push back the protective sheathing to expose two good wires.

- (C) Twist the two wires together tightly 3 or 4 turns (use two pairs of pliers) then trim off long ends. Be sure the metal sheathing does not contact the twisted wires.

NOTE: This is only a temporary repair and the thermocouple should be replaced as soon as possible.

If replacement was necessary be sure the thermocouple connections at the junction box are connected to the two center screws in their proper positions.

The yellow (positive) wire is connected to the top center screw and the red (negative) wire is connected to the bottom center screw. (Be sure you are on the two center screws.) Use type "K" thermocouple only.

Notes _____

10. SNAP DISC #1 (Convection Blower)

The function of this snap disc is to turn the convection blowers on and off as needed. This disc senses the temperature of the air in the convection air chamber and turns the blower on when the temperature reaches 127°F and turns it off at 107°F. (Note: on some earlier models temperature values are set at 145°F "on" and 105°F "off"). Should this disc fail, the blower will either run continually or fail to turn on. Replace if either problem occurs.

This disc is the first snap disc from the right side of stove and has two orange wires and one purple wire running to it. This disc will have the numbers F127-20 on it's side. See Figure #1 Page 18.

Notes _____

11. SNAP DISC #2 (Thermostat Override)

This snap disc will turn the stove off if an over fire condition occurs or if the convection blower should fail to operate. This disc opens at 250°F and opens the thermostat circuit and shuts off the red indicator light located on the right side of the stove. This disc will automatically reset when the stove cools down. If the thermostat will not turn the stove on, check this disc to make sure current will pass through it by jumping across its terminals. If not, replace this snap disc. This is the second snap disc from the right side of stove and has two yellow wires running to it. This disc will have the numbers L250-40F on it's side. See Figure #2 Page 19.

12. **SNAP DISC #3** (Back Burn Protector)

If for any reason this stove tries to burn back into the feed system or push exhaust up the feed tube, this snap disc will shut the entire system off at 200°F. However, sometimes in shipment this disc will trip and shut power off to the entire stove. To reset this disc **unplug the stove** and push in the red button in the center of the snap disc and then plug the stove back in. This disc is on the left hand side of the stove and is mounted on the round feed tube. It has two wires going to it, one gray wire and one orange wire. The gray wire brings power from the fuse in the junction box and the orange wire takes power back to snap disc #1 for the convection blower and also to the control box to power the stove. See Figure #1 Page 18.

Notes _____

13. **BLOWER #1** (Small Convection Blower)

This blower is located on the right hand side of the stove and is accessible through the right side panel. However, if replacement is necessary it will be easier to change it by pivoting the stove out of the fireplace so you can access the right rear panel. This blower delivers convection air through it's own air channel to the front of the stove. Should this blower fail, you may find snap disc #2 or possibly snap disc #3 tripping. Unlike the other blowers on this model, this blower does not require an external capacitor. The purple wire that comes from snap disc #1 turns this blower on along with the large convection blower (Blower #3). See Figure #1 Page 18.

Notes _____

14. **BLOWER #2** (Negative Draft Exhaust Blower)

This blower is located on the left side and at the rear of the stove. The function of this blower is to pull all of the exhaust out of the firebox. It creates a negative pressure or vacuum in the firebox. Power is supplied to this blower (See Figure #4 Page 20) via the blue wire coming from the wiring harness. The blue wire plugs into the capacitor marked 3uf. The black wire from the blower connects to the capacitor on the same side of the capacitor as the blue wire coming from the harness. The brown lead coming from the blower plugs into the capacitor on the opposite side. It is not important which side the wires plug into, only that the

black wire from the blower and the blue wire from the harness plug into the same side and that the brown wire plugs into the opposite side. The light blue lead coming from the blower plugs into the white lead (ground) that comes from the wiring harness. There is also a green wire coming from the blower that also needs to connect to the body of the stove which supplies another ground for the blower. Should this blower shut down or fail, a positive pressure will exist in the firebox. As a result the vacuum switch will turn off the feed motor. If blower replacement becomes necessary, you will have to first unplug the stove from power, disconnect the exhaust and pivot the insert out of the fireplace exposing the left rear panel. There are two different styles of shrouds. On the earlier models you needed to remove the access door which is easier to remove than the newer models where you have to remove the entire side panel. However, on the newer models with the side panel removed you have greater access to the blower. With the access door or side panel removed, you will now have a clear view of the blower. To change this blower follow these instructions:

1. Unplug the stove.
2. Remove left front side panel.
3. Disconnect the black and brown wires from the capacitor and the blue wire from the white wire on the wiring harness. The green wire connected to the stove body must also be removed. See Figure #4 Page 20.
4. Remove the small access door which allows you to disconnect the exhaust system. Release the two quick disconnect latches that hold the exhaust in place. Now with the exhaust system disconnected, pivot the insert out on to the hearth.
5. Remove the rear access door on earlier models or the rear side panel on later models. You should now be able to see the blower.
6. Remove the outer row of screws which secure the blower to the blower housing. Note: The blower has had silicone applied to both sides of the gasket so it may be necessary to use a scraper or small screwdriver to free the blower from it's housing.
7. Clean the blower housing by removing the old gasket and silicone.
8. When reinstalling the blower, be sure to use high temp silicone on both sides of the gasket.
9. Reinstall in reverse order.

15. BLOWER #3 (Convection Air 160 CFM)

This blower is located on the left hand side of the stove, and is accessible by removing the front left side panel. It is the first blower that you see. The purpose of this blower is to circulate air over the heat exchanger and into the room. It is controlled by a snap disc that turns the blower on when the temperature reaches 127°F. At 107°F this switch shuts the blower back off. Power is supplied to this blower (See Figure #1 Page 18) via the purple wire coming from the wiring harness. The purple wire plugs into the capacitor marked 4uf. The black wire from the blower connects to the capacitor on the same side as the purple wire coming from the harness. The brown lead coming from the blower plugs into the capacitor on the opposite side. It is not important which side the wires plug into, only that the black wire from the blower and the purple wire from the harness plug into the same side and that the brown wire plugs into the opposite side. The light blue lead coming from the blower plugs into the white lead (ground) that comes from the wiring harness.

Note: On some earlier models the snap-disc temperatures are set at 145°F and 105°F in some cases this may be too high of a setting and blower reaction time may be too slow. If so, the snap disc may need replacement.

If this blower fails, the temperature in the convection air chamber will increase. When the temperature reaches 250°F. at snap disc #2, (thermostat override refer to Figure #2) it will open the thermostat circuit and turn off the red indicator light located on the right side of stove until it cools down. Then the stove will automatically relight.

To replace this blower follow these instructions:

1. Unplug the stove.
2. Remove left front side panel.
3. Disconnect the black and brown wires from the capacitor and the blue wire from the white wire on the wiring harness. See Figure #1 Page 18.
4. Remove the four mounting bolts and remove the blower. On earlier models a gasket was used and on later models silicone was used for the gasket.
5. To install a new blower, inspect the gasket and replace it if damaged or use silicone. Then follow the above instructions in reverse order.

16. FEED SYSTEM

This system pulls pellets up the feed tube from the hopper and drops them down the feed chute into the firepot. The feed motor along with the vacuum switch, are mounted on the left hand side of the stove. The feed system has a fuel adjustment plate located inside the hopper at the very bottom of the hopper. The adjustment plate will restrict the amount of pellets that can go into the feed system. This is how we adjust feed rate. If the fire is too large, slide the feed adjustment plate down. If the fire is too small, slide the feed adjustment plate up. On earlier models there seemed to be some bridging problems in the bottom of the hopper when the feed adjustment plate was at a lower setting. There is now available for any of the earlier models a new feed adjustment plate. This new plate has an angle cut at the bottom and has greatly reduced any bridging problems. See Figure #3 Page 19.

The feed system consists of the following replaceable parts:

- 1 - 120 volt AC 2 rpm gear motor
(1 rotation in approximately 30 seconds)
- 1 - thrust bushing collar
- 1 - feed spring and coupler assembly
- 1 - nylon bearing
- 2 - bearing mounting nuts and washers
- 4 - motor mounting screws
- 1 - motor-bearing mount assembly

Assuming there are pellets in the hopper and the stove fails to feed:

1. When the test box is available, use it and consult the Test Box Operating Instruction Manual. (Refer to page 4 Section VI. FEED-M.)
2. If the test box is not available, continue to step #3.
3. Check to see if blower #2 (negative draft blower) is operating. If this blower fails, vacuum will not be present and the feed motor cannot turn on. In order for the vacuum switch to turn on the feed motor, vacuum must be present in the firebox. (For failed blower refer to Section #14 Page 11 of this manual.) If the blower is operating continue to step #4.
4. When the negative draft blower is running, and the front door is closed and the feed motor still doesn't run, Continue to step #5.
5. With the red light on the side of the junction box on, press the restart button and check the red wire (+) that goes to the vacuum switch and the white wire (-) that goes to the feed motor for 120 volts of AC power.

If power is present, the vacuum switch may be the problem. An easy test of the vacuum switch is to remove the vacuum hose from the fitting on the feed tube. Then press the restart button. Now apply a slight suction on the open end of the hose with your mouth, and the feed motor should start. If the feed motor runs while applying suction on the hose refer to Section 5 (VACUUM SWITCH ADJUSTMENT PROCEDURES) of this manual. If power is present and the feed motor doesn't run continue to step #6 for motor removal instructions.

6. To access the motor, remove the left side panel.
7. Remove the two bearing mounting nuts and the entire feed assembly will pull out of the stove. It is not necessary to remove the fuel from the hopper to reinstall the feed assembly. Just push the assembly into the feed tube until it stops and then connect the motor to power and it will auger itself back into position.

Notes _____

17. IGNITER

The igniter is located in a bottom chamber of the firepot suspended above the lower end of the ramp on the clean out plug. The igniter is made of a cast silicon carbide ceramic material. The element quickly reaches a temperature of 2600°F when 120 volt AC power is applied. Superheated air passes around the igniter lighting the pellets on the ramp beneath it. This flame then flows up the ramp into the main burn chamber of the firepot where it ignites the rest of the pellets.

This igniter may be visually inspected by removing the clean out plug from the firepot.

SPECIAL CARE MUST BE TAKEN NOT TO BREAK THE IGNITER ELEMENT, IT IS VERY BRITTLE!

Improper cleaning of the firepot can cause glazing of the igniter due to fuel or ash coming into contact with it. Glazing will cause rapid deterioration of the element and replacement will soon be necessary. If it is necessary to change the igniter, follow these steps:

1. Unplug the stove from outlet !
2. Open the front pedestal access door and remove the clean out plug and ashpan.

3. Open the main door and remove the ashpans
4. Gently move the thermocouple and protection tube away from the firepot.
5. Now rotate the firepot in a counter clockwise direction until the igniter wires are forward and the wire nuts are easy to remove. With the wire nuts removed and wires separated, rotate the pot back to it's original position.
6. Gently lift and tip the firepot forward and lift it out the front door.
7. Remove the old igniter and carefully insert the new igniter. Be sure it is centered in the opening. The gasket around the igniter must be pressed tightly between the igniter base and the firepot. A small screwdriver will be a big help. ANY SIDE PRESSURE ON THE ELEMENT WILL CAUSE BREAKAGE!
8. Reinstall the firepot through the front door (*careful of the wires!*) and repeat steps 1-5 in reverse.

Notes _____

18. FIREPOT

The firepot is made of cast ceramic and is designed with air intake ports (holes) that swirl the fire and help to remove ash. There is also a slot or air passage about 1 inch up from the bottom of the firepot that supplies the ignition air to the igniter. If the stove is missing ignitions, it is possible that the igniter is receiving too much air. The ideal slot size is 3/4" of an inch in width and a little under 1/4" of an inch thick. If the hole is larger than that, you may restrict the air inlet with stove gasket cement or like material. It is also important that the firepot makes a good seal with the hole that it fits into. There should be a ring shaped gasket between the firepot and the firebox floor. The gasket itself has four tabs pointing into the center that protect the pot during shipping. Some times during setup when the cardboard packaging under the firepot is being removed one or more of the tabs will fold up between the gasket and the firepot and prevent a good seal. If this happens you can cut the tabs off of the gasket and reuse it. If removing the firepot be sure to inspect this gasket and replace if need be. (Flat stove glass mounting gasket may be substituted here).

If it should be necessary to change the firepot, follow the instructions in Section 17 on changing the igniter.

19. EXHAUST

If the exhaust is dirty or plugged the vacuum switch will keep the feed system from coming on. Check the chimney system, exhaust, and end cap for blockage. **Be sure all joints are sealed with High Temp Silicone.**

Notes _____

20. DOOR AND LATCH

The door latch is adjusted by removing the nut on the back of the door latch. Remove the latch cam and square key and then add or subtract washers as needed and re-assemble.

Notes _____

21. HEAT EXCHANGER

There is one aluminum finned heat exchanger in this stove. It is located on the right side of the firebox and is accessible through the front door. There is a stainless steel cover for the heat exchanger, and it's purpose is to direct the air flow into the top so that the exhaust has to pass the full length of the exchanger. We have made an improvement on the design of the baffle that creates a more even air flow over the heat exchanger and also improves the flame pattern. It is called a flame enhancement kit and is an upgrade that we would like to see put on all the early stoves. If during the cleaning of the heat exchanger you notice some fin degradation, where the top corner of some fins has experienced a little melting, it will be necessary to replace the heat exchanger with a new one where the fins are cut at an angle. This will eliminate the possibility of melting. If replacement is necessary follow the instructions below.

Heat Exchanger Removal Instructions

1. Remove right side panel by removing 2 screws (A) Refer to page 22, Figure 8 for Heat Exchanger Removal.
2. Remove control box Figure 9.
3. Disconnect wiring loom from junction box as shown in Figure 10.
4. Then disconnect the thermocouple and remove junction box.

5. Disconnect the wires from snap discs #1 and #2. (See Figures 1 & 2) Remove the 17 screws mounting the heat exchanger cover door and remove the door. See Figure 11
6. Remove all mounting nuts that secure the heat exchanger in place. With all mounting nuts removed, open the main door into the burn pot. Remove stainless steel cover from the heat exchanger. Then by inserting a pry bar between the heat exchanger and the firebox floor, you will be able to pry the heat exchanger away from the gasket. (The heat exchanger gasket is siliconed on both sides which makes it difficult to remove).

Heat Exchanger Installation

1. There are seven press studs, and one pin that must be removed to install the stud bar. Use a hammer and punch to remove the studs. The pin will have to be cut off. To do this use a grinder or open ended hack saw. It must be cut or ground flush with the wall. See Figure #15 Page 24.
2. Using the firepot scraper, remove all gasket and silicone on the heat exchanger mount.
3. Install the stud bar by aliening the studs with the holes. This will be easier to do if you enlarge the seven holes by using a 5/16 inch drill bit. See Figure #16 Page 24.
4. Put a bead of silicone on the heat exchanger mount. Then place the gasket onto the mounting studs. Now place another bead of silicone on the gasket.
5. Install heat exchanger onto mounting studs. Start all of the nuts on all the studs except the two studs that hold the deflector plates as per (Figure 12). Tighten all of the nuts to 8 foot pounds of torque and then install deflector plates. The left deflector plate should contact the top left fin and also the left side of the convection air channel. It's purpose is to stop all air flow from passing up that channel. Install as per (Figure 14) and tighten nut. Install the deflector plate on the right side of the heat exchanger. The top of this plate should contact the top of the shroud and also the aluminum fin. And it's purpose is to stop the flow of air from passing the right hand corner of the heat exchanger. Silicone may be used to close any gaps. Tighten mounting nut on the deflector plate.
6. Reinstall heat exchanger cover plate, be sure to put a small bead of silicone around the mounting surface.

7. Reconnect the two yellow wires to snap disc #2 at the rear of the cover plate.
8. Remove snap disc #1 and replace it with the new snap disc supplied. (This snap disc will turn the convection blower on a little sooner). Be sure to reconnect the wires.
9. Reinstall the junction box and electronics (Note that when installing the thermocouple wires that the red wire goes on top)
10. Inside the firebox, reinstall the stainless steel heat exchanger cover and using a 7/16 inch socket tighten the mounting nut. Be sure the nut is adjusted so that the cover can still be removed easily by the consumer.

Notes _____

Heat Exchanger Cleaning Instructions

1. Remove stainless steel heat exchanger cover from inside of the firebox.
2. Remove heat exchanger cleanout cover located on the right of the firepot. See Figure #6 Page 21.
3. Brush or scrape the fins to remove ash.
4. Vacuum underneath the heat exchanger through clean out opening.

Note: When reinstalling cleanout cover be sure to turn both latches all the way to the right. This will insure a good seal.

22. STAINLESS STEEL FIREBOX LINER

This back plate is just a liner designed to protect the firebox. It is replaceable and just slides in through the front door. It is supported from the top of the firebox by two tabs that slide into the notches in the liner. There is a notch in the liner that lets the pellets that come down the feed tube fall past the liner. On some of the early stoves the liner would creep ahead a little and cause pellets to occasionally miss the firepot. If this is the case, replacing the liner with a new one will solve the problem. The new liners have a larger notch around the feed tube and will eliminate any interference problems.

Notes _____

23. OUTSIDE AIR & AIR ADJUSTMENTS

The outside air kit (Part #811-0210) when installed will let the stove draw air from outside of the rear shroud right in front of the exhaust outlet. The kit consists of two main parts (1) a flexible hose and (2) a 3" inch adapter that mounts to the top of the rear shroud. When installing this kit be sure that the flexible hose does not rub the exhaust blower and impair it's operation. See Instructions Page #25.

There is an air adjustment on this stove located next to the bottom of the firepot on the left side. See Figure #7 Page 21. It is a round flap that pivots over the air inlet hole. This flap will either increase or decrease the amount of air flow into the firepot. The best setting for most installations is to have the flap three quarters of the way open, however this will vary depending upon fuel and venting.

Notes _____

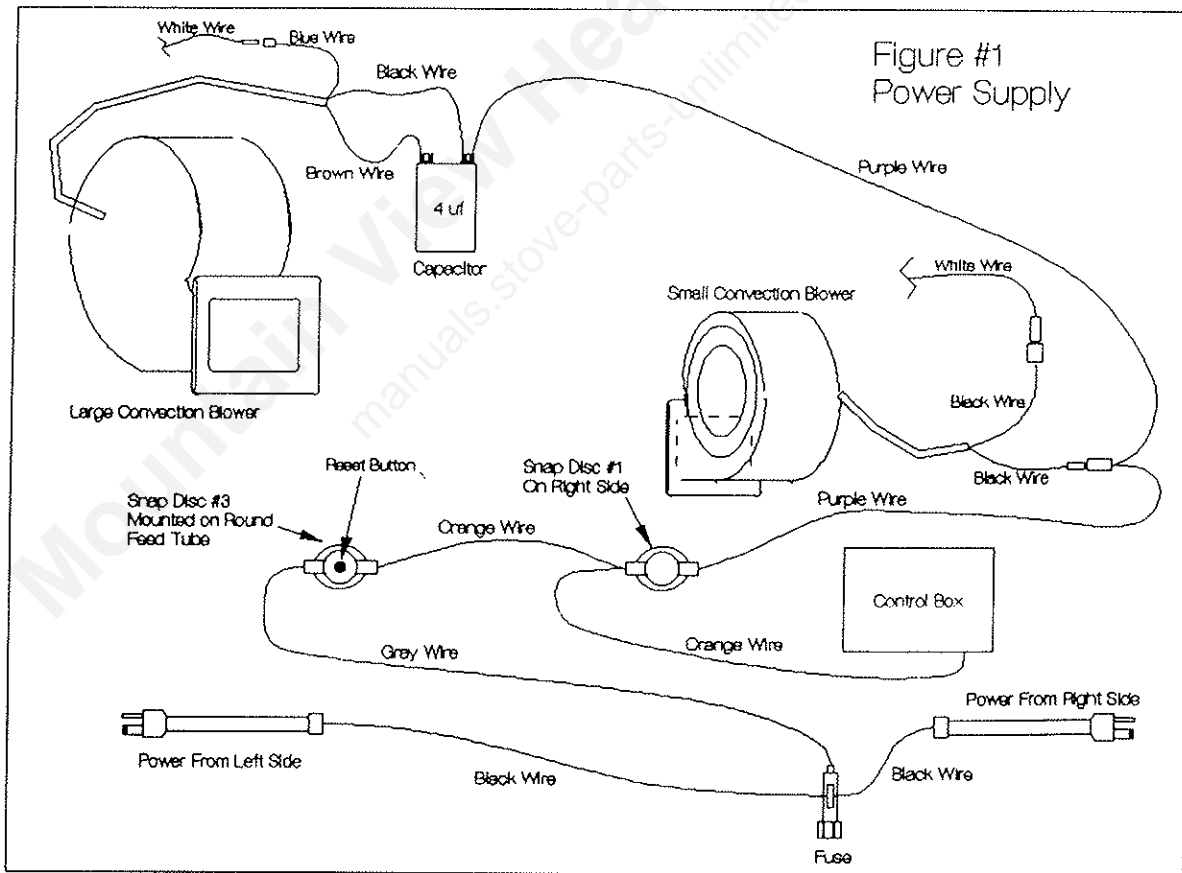

Figure # 2 Thermostat Wiring

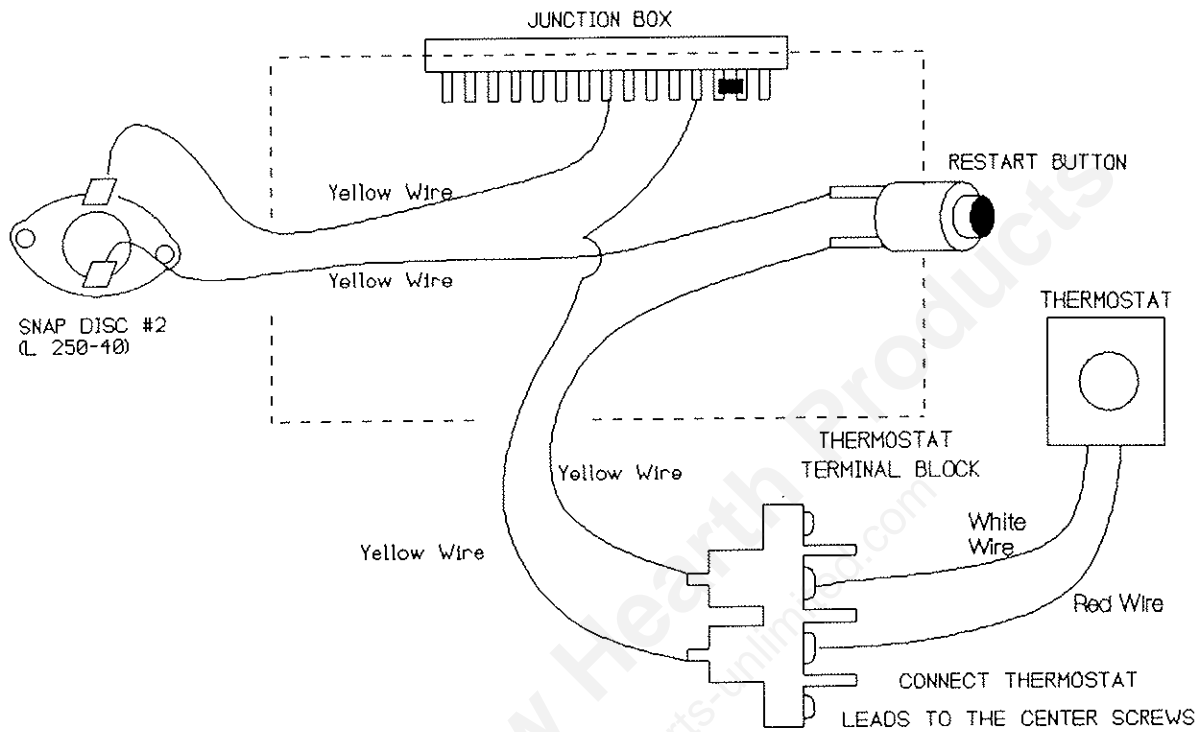

Figure # 3 Feed Adjustment

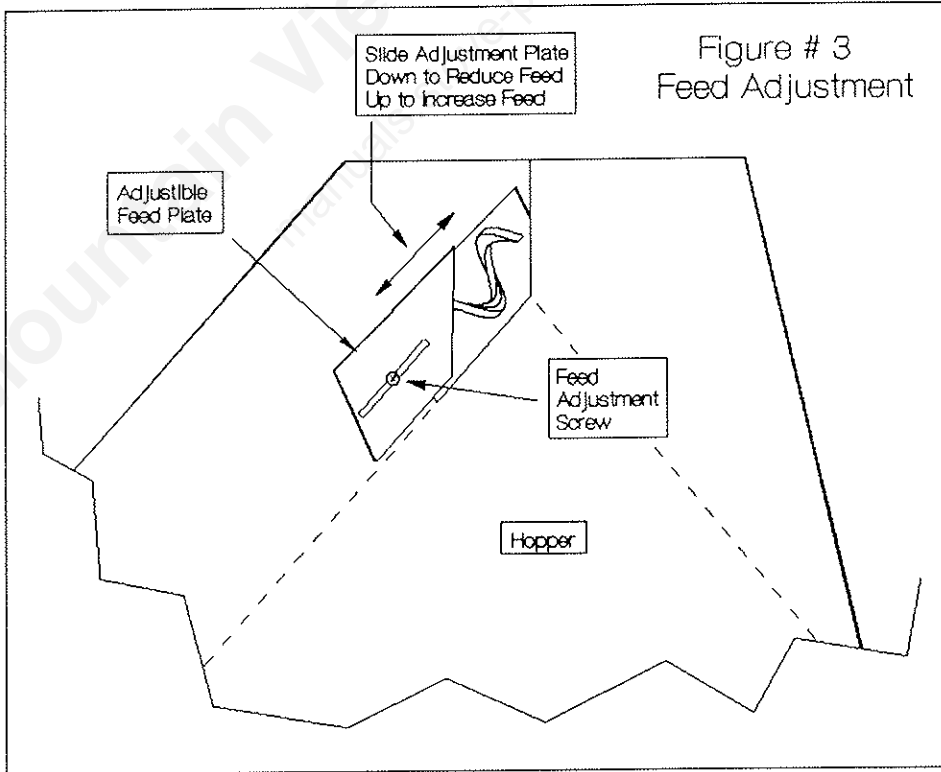

Figure # 4
Exhaust Blower Wiring

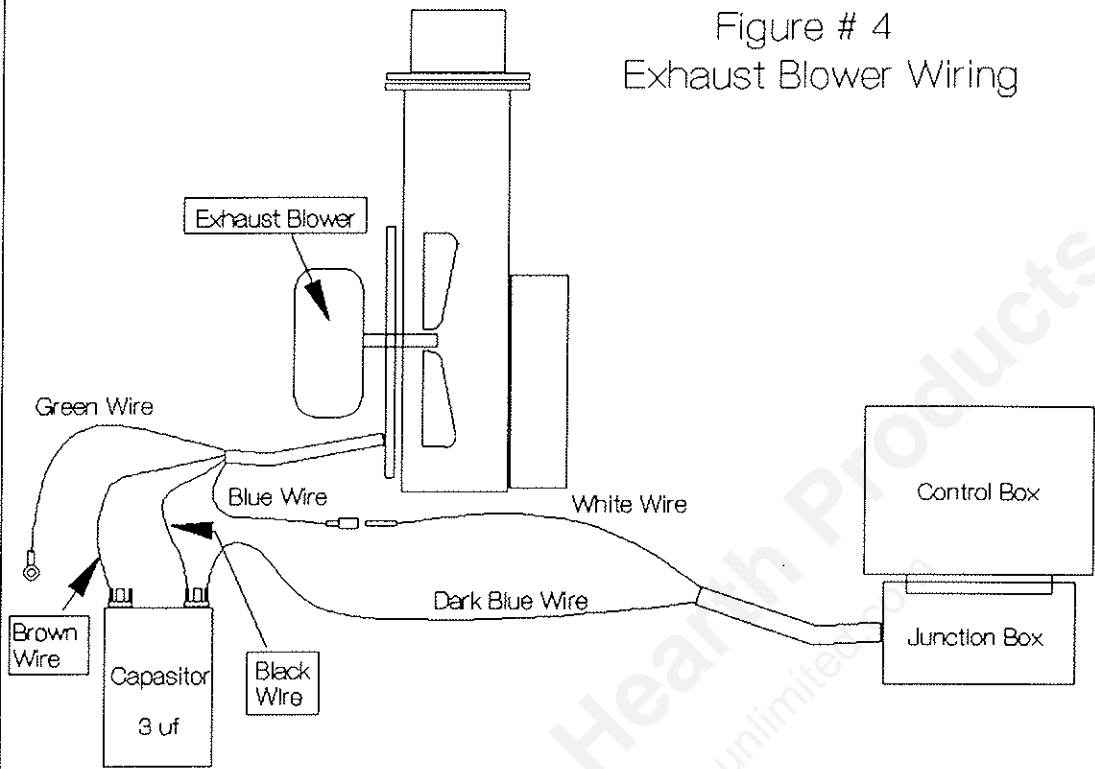
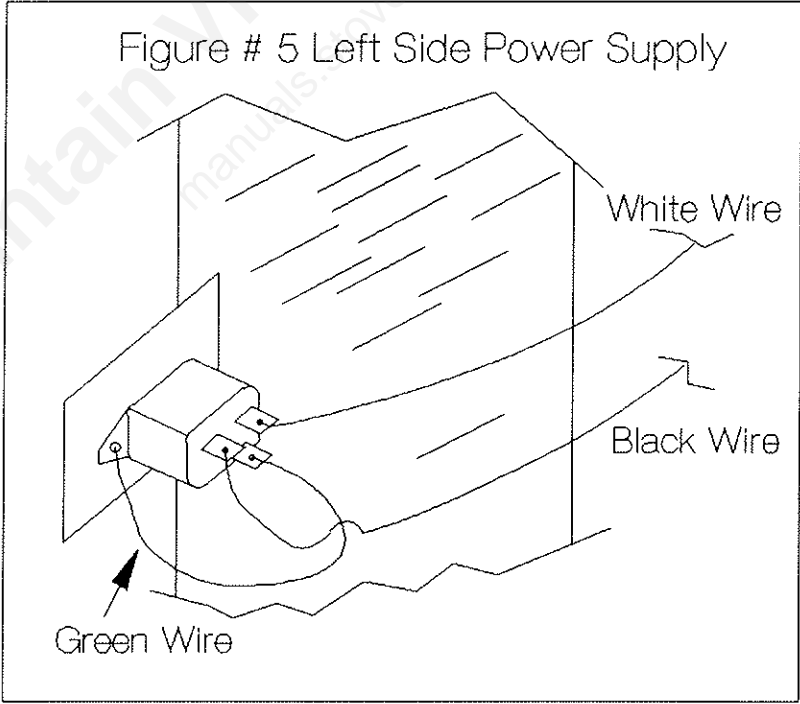
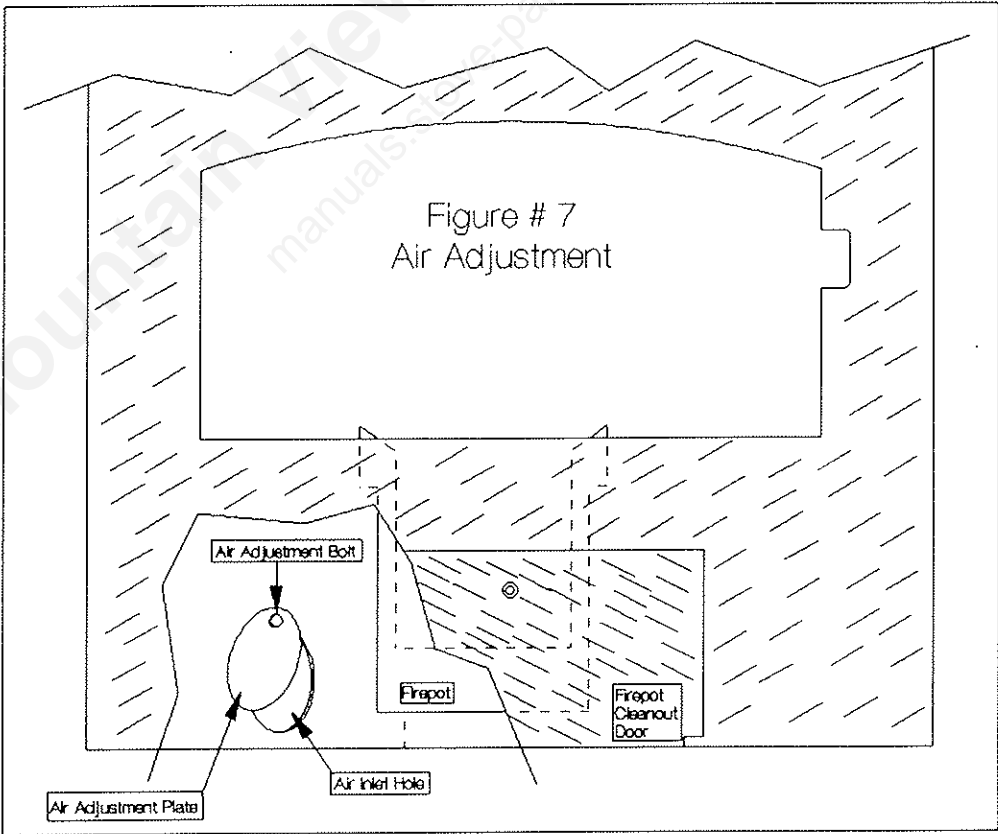
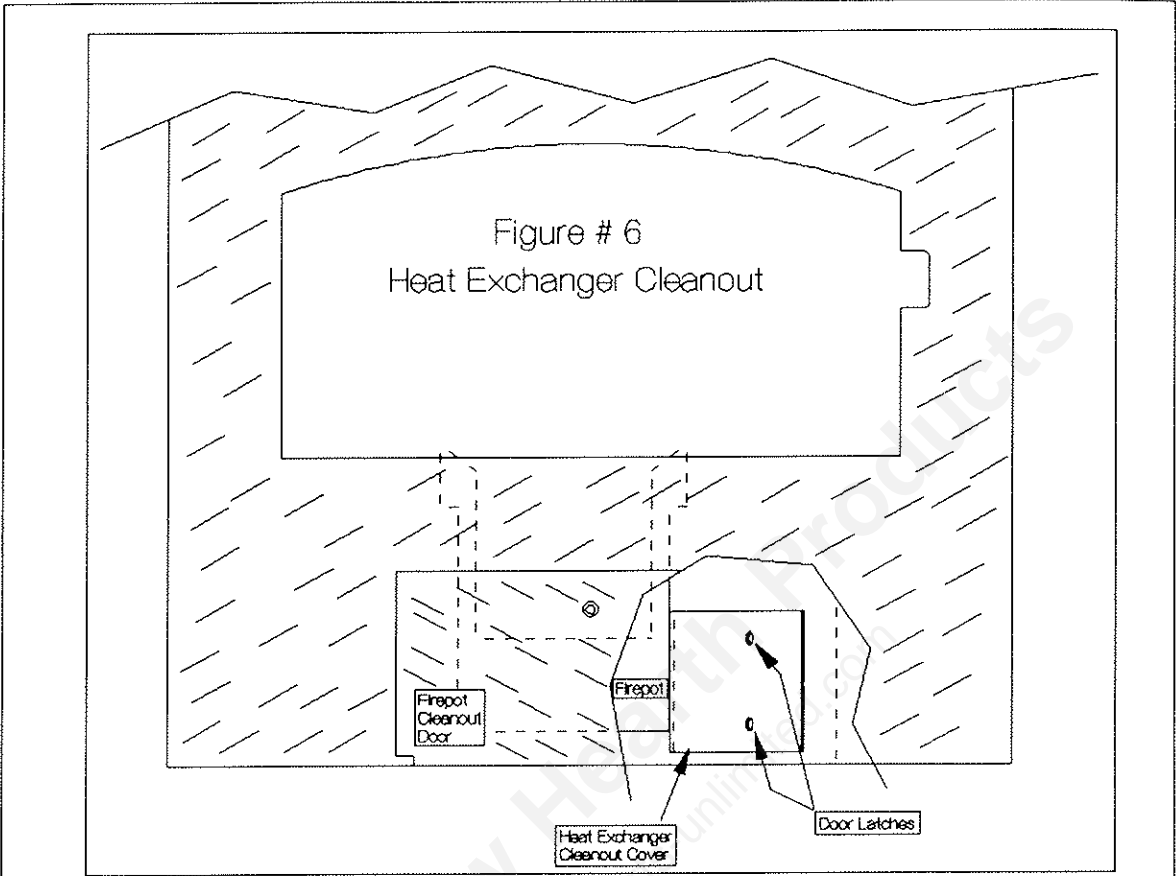
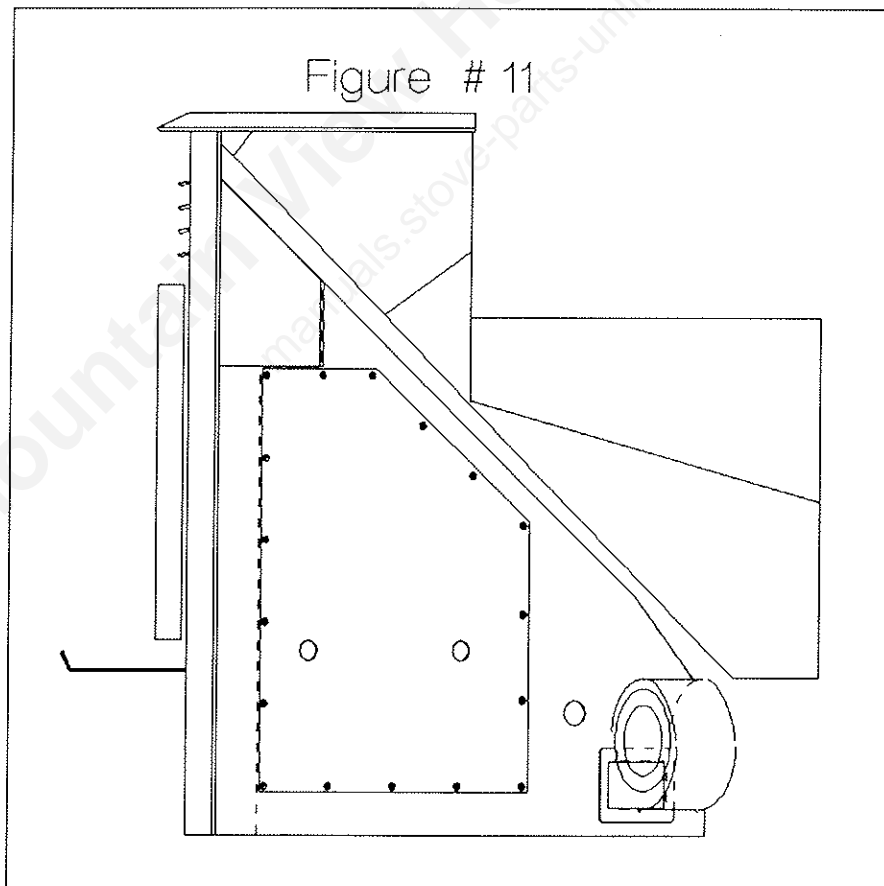
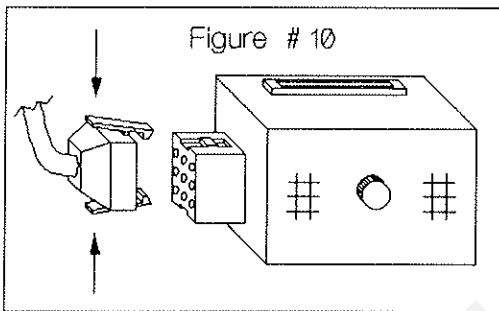
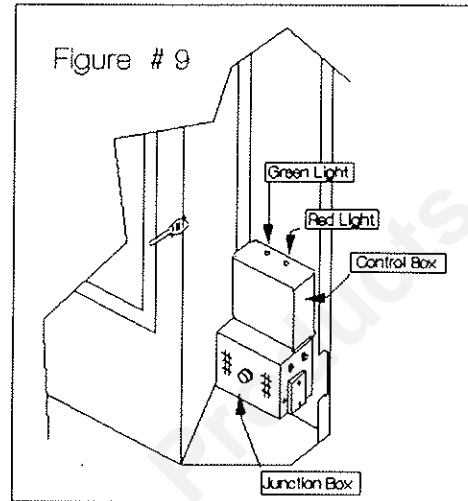
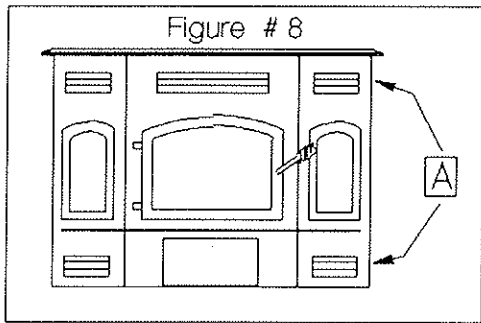

Figure # 5 Left Side Power Supply





Heat Exchanger Replacement Instructions



Heat Exchanger Replacement Instructions

Figure # 12

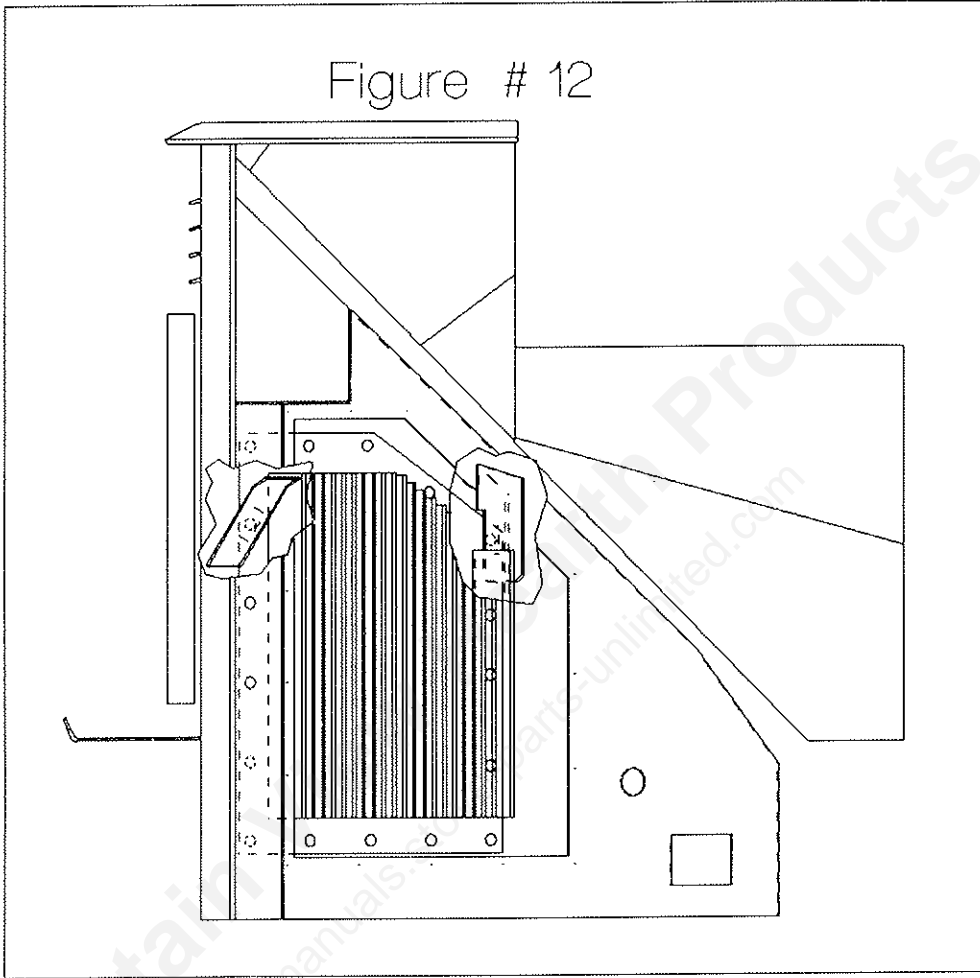

Figure # 13 (Left Side)

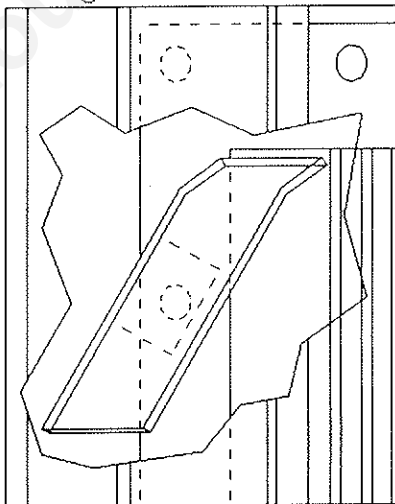
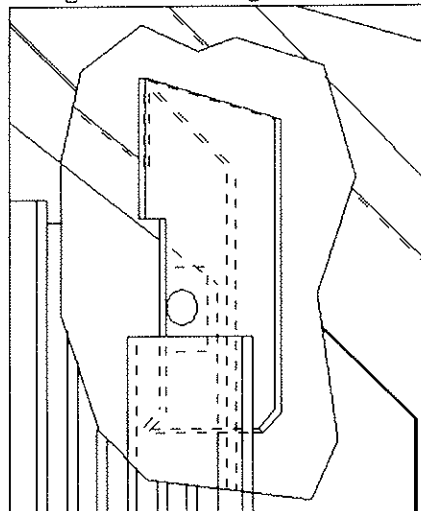
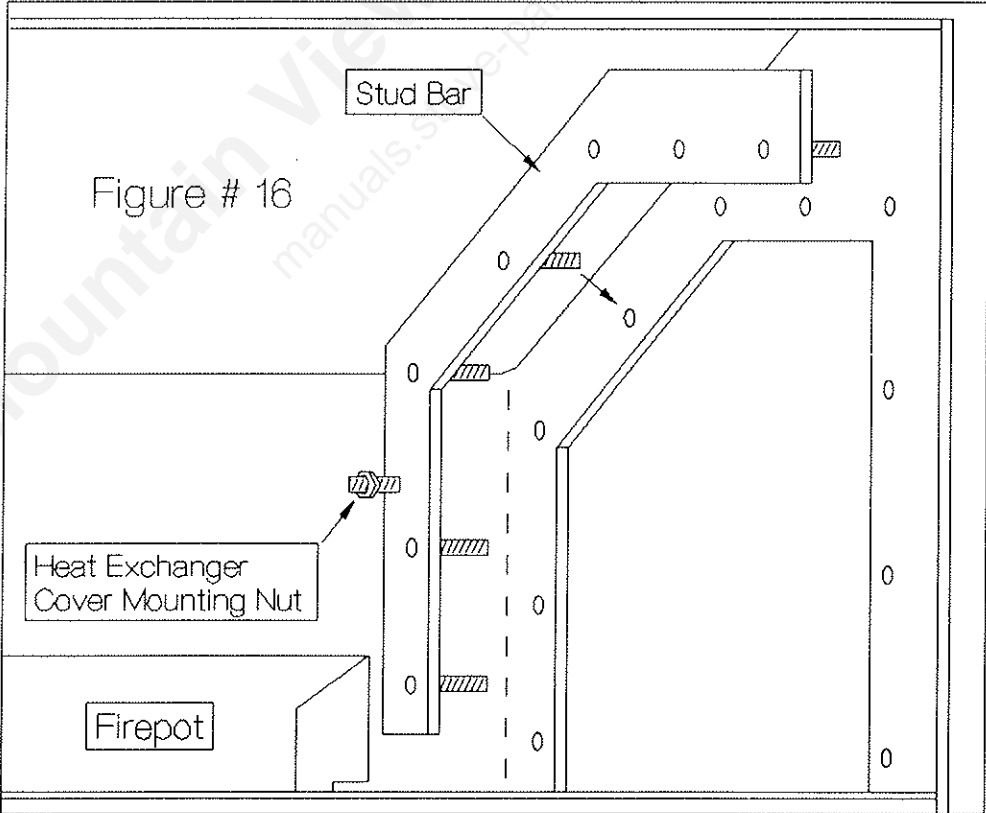
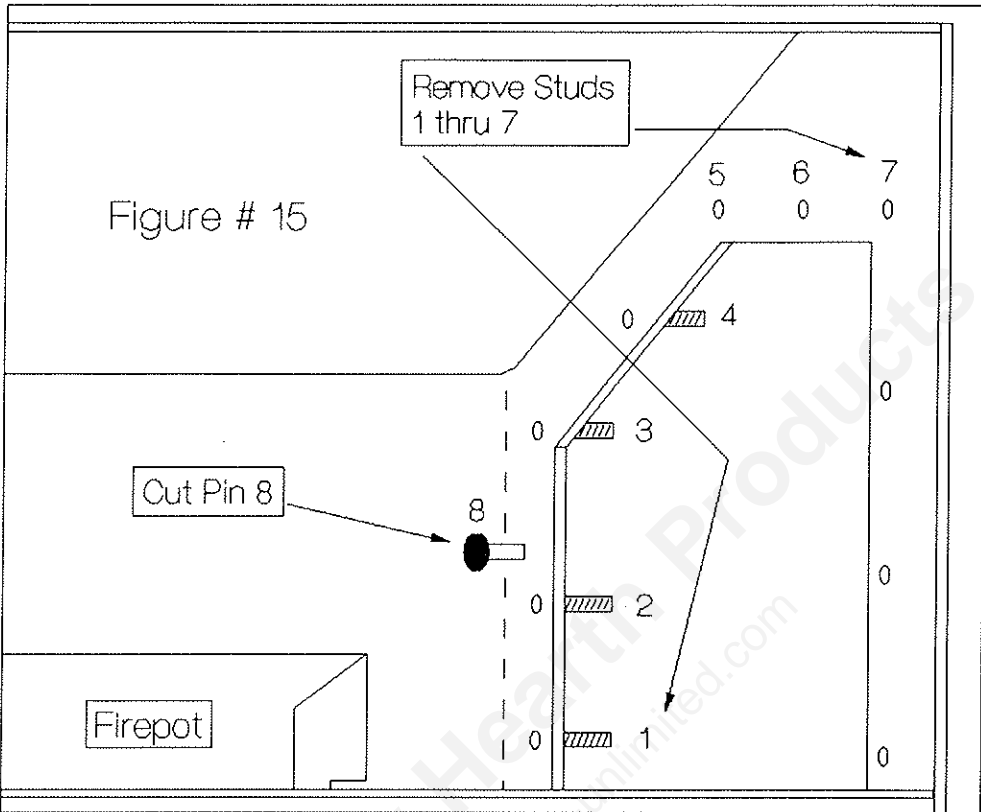

Figure # 14 (Right Side)





Outside Combustion Air Kit # 811-0210

Figure # 15

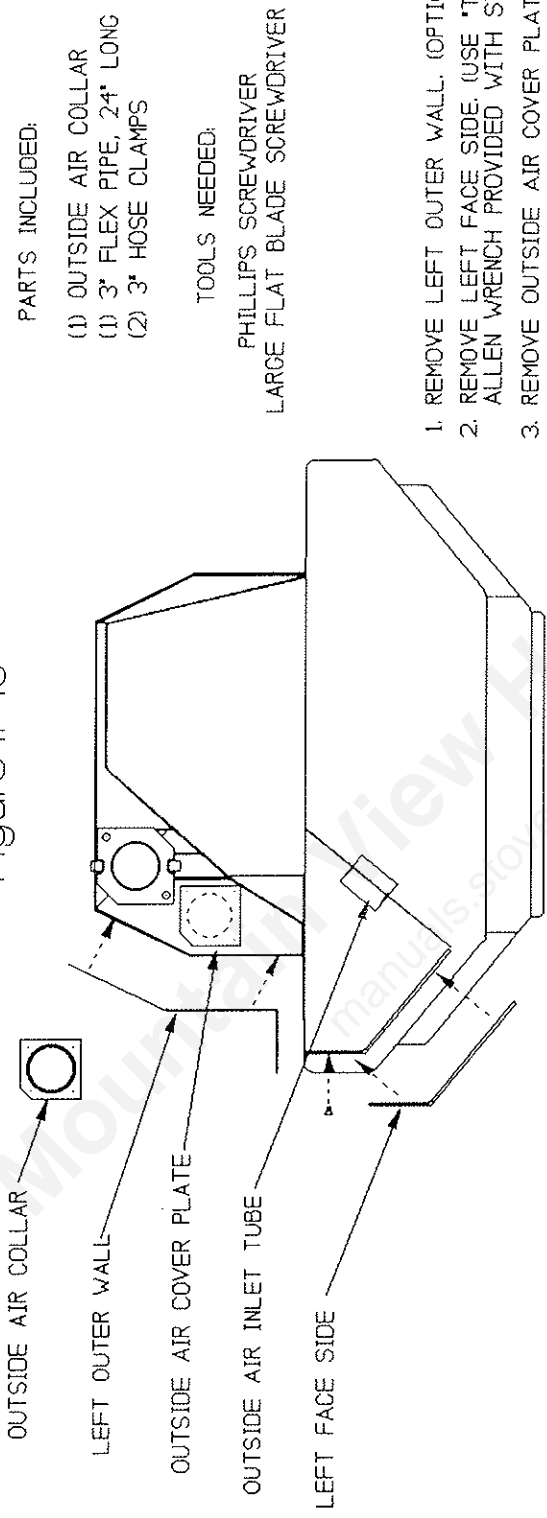

PARTS INCLUDED:

- (1) OUTSIDE AIR COLLAR
- (1) 3" FLEX PIPE, 24" LONG
- (2) 3" HOSE CLAMPS

TOOLS NEEDED:

- PHILLIPS SCREWDRIVER
- LARGE FLAT BLADE SCREWDRIVER

1. REMOVE LEFT OUTER WALL. (OPTIONAL)
2. REMOVE LEFT FACE SIDE. (USE "T" HANDLE ALLEN WRENCH PROVIDED WITH STOVE)
3. REMOVE OUTSIDE AIR COVER PLATE.
4. INSTALL OUTSIDE AIR COLLAR IN PLACE OF COVER PLATE.
5. ATTACH FLEX TUBE TO BOTTOM SIDE OF COLLAR.
6. ATTACH THE OTHER END OF FLEX TUBE TO OUTSIDE AIR INLET TUBE.

NOTE: BE SURE FLEX TUBE DOES NOT TOUCH ANY MOVING PARTS INSIDE OF STOVE. A LITTLE TWIST BEFORE TIGHTENING HOSE CLAMP WILL POSITION TUBE.

7. REPLACE FACE SIDES AND LEFT OUTER WALL.

