

QUADRA-FIRE®

CASTILE PELLET STOVE

Owner's Manual Installation and Operation

Model:
CASTILE-MBK1
CASTILE-PMH1
CASTILE-CSB
CASTILE-CWL

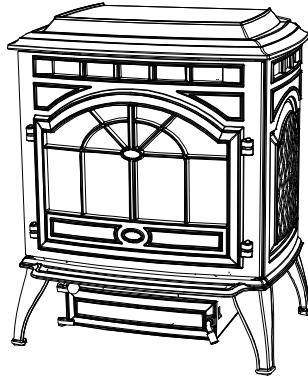

Tested and
Listed by  Portland
Oregon USA
C US
OMNI-Test Laboratories, Inc.



CAUTION



DO NOT DISCARD THIS MANUAL

- Important operating and maintenance instructions included.
- Read, understand and follow these instructions for safe installation and operation.
- Leave this manual with party responsible for use and operation.

**DO NOT
DISCARD**



WARNING



Please read this entire manual before installation and use of this pellet fuel-burning room heater. Failure to follow these instructions could result in property damage, bodily injury or even death.

- Do not store or use gasoline or other flammable vapors and liquids in the vicinity of this or any other appliance.
- Do not overfire - If any external part starts to glow, you are overfiring. Reduce feed rate. Overfiring will void your warranty.
- Comply with all minimum clearances to combustibles as specified. Failure to comply may cause house fire.



WARNING



**HOT! DO NOT TOUCH.
SEVERE BURNS MAY RESULT.
CLOTHING IGNITION MAY RESULT.**



Glass and other surfaces are hot during operation and cool down.

- Keep children away.
- CAREFULLY SUPERVISE children in same room as appliance.
- Alert children and adults to hazards of high temperatures.
- Do NOT operate with protective barriers open or removed.
- Keep clothing, furniture, draperies and other combustibles away.

CAUTION

Tested and approved for wood pellets and shelled field corn fuel only. Burning of any other type of fuel voids your warranty.

CAUTION

- Check building codes prior to installation.
- Installation MUST comply with local, regional, state and national codes and regulations.
 - Consult local building, fire officials or authorities having jurisdiction about restrictions, installation inspection, and permits.

Congratulations 
and Welcome to the Quadra-Fire Family!







Hearth & Home Technologies welcomes you to our tradition of excellence! In choosing a Quadra-Fire appliance, you have our assurance of commitment to quality, durability, and performance.

This commitment begins with our research of the market, including 'Voice of the Customer' contacts, ensuring we make products that will satisfy your needs. Our Research and Development facility then employs the world's most advanced technology to achieve the optimum operation of

our stoves, inserts and fireplaces. And yet we are old-fashioned when it comes to craftsmanship. Each unit is meticulously fabricated and surfaces are hand-finished for lasting beauty and enjoyment. Our pledge to quality is completed as each model undergoes a quality control inspection.

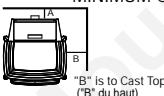
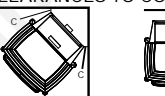
We wish you and your family many years of enjoyment in the warmth and comfort of your hearth appliance. Thank you for choosing Quadra-Fire.

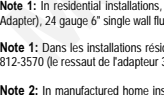
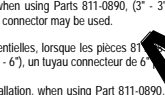
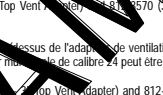
SAMPLE OF CLEARANCE TO COMBUSTIBLES LABEL
LOCATION: Back side of left side panel.

 Tested and Listed by UL Underwriters Laboratories, Inc. Portland, Oregon USA	Report / Rapport 061-S-33-2		Castile Pellet Stove	SERIAL NO. / NUMÉRO DU
<p>Listed Solid Fuel Room Heating Pellet Type Insert. Also suitable for Mobile Home Installation. This appliance has been tested and listed for use in Manufactured Homes in accordance with OAR 814-23-9000 through 814-23-909.</p> <p>Appareil de chauffage inséré de combustible solide type de boulettes. Accepté dans l'installation dans les maisons mobiles. Cet appareil a été testé et enregistré pour l'usage dans les Maisons Mobiles en accord avec OAR 814-23-9000 jusqu'à 814-23-909.</p>				
<p>Tested to: ASTM E1509-95, ULC S627-00, ULC/ORD-C-1482-M1990 Room Heating Pellet Burning Type, (UM) 84-HUD FOR USE ONLY WITH PELLETIZED WOOD OR SHELLED FIELD CORN FUEL.</p> <p>Testé à: ASTM #1509-95, ULC S627-00 ULC/ORD-C 1482-M1990 Room Heating, Pellet Burning Type, (UM) 84-HUD POUR USAGE AVEC LES BOULETTES DE BOIS OU DE COMBUSTIBLE D'UN MAIS ECOSSÉ DES CHAMPS.</p> <p>Puissance de Rendement: 30,000 Btu/hr Puissance Électrique: 115 VAC, 60 Hz, Écoul 4.1 Amps, Courir 1.1 Amps Éloignez le fil électrique de l'appareil. Ne pas faire passer le fil électrique au dessus ou en dessous de l'appareil. DANGER: Il y a risque de décharge électrique. Déconnectez le fil électrique de la prise de contact avant le service.</p>				
<p>PREVENT HOUSE FIRES / PRÉVENTION DES FEUX DE MAISON</p> <p>Install and use only in accordance with manufacturer's installation and operating instructions. Contact local building or fire officials about restrictions and inspection in our area.</p> <p>WARNING - FOR MOBILE HOMES: Do not install appliance in a sleeping room. An outside combustion air inlet must be provided. The structural integrity of the mobile home floor, ceiling and walls must be maintained. Refer to manufacturer's instructions and local codes for precautions required for passing chimney through a combustible wall or ceiling. Inspect and clean vent system frequently in accordance with manufacturer's instructions.</p> <p>DO NOT CONNECT THIS UNIT TO A CHIMNEY SERVING ANOTHER APPLIANCE.</p> <p>Use a 3" or 4" diameter type "L" or "PL" venting system.</p> <p>Installez et utilisez en accord avec les instructions d'installation et d'opération du fabricant. Contactez le bureau de la construction ou le bureau des incendies au sujet des restrictions et des inspections d'installation dans votre voisinage. Ne pas obstruez l'espace en dessous de l'appareil.</p> <p>AVIS - Pour Les Maisons Mobiles: Ne pas installer dans une chambre à coucher. Un tuyau extérieur de combustion d'air doit être installé et ne doit pas être en contact avec l'appareil. La structure intégrale du plancher, du plafond et des murs de la maison mobile doit être maintenue intacte.</p> <p>Refer to the instructions du fabricant et des codes locaux pour les précautions requises pour passer une cheminée à travers un mur ou un plafond combustibles, et les compensations maximums.</p> <p>Utilisez un système de ventilation de type "L" ou "PL" diamètre 76mm ou 102mm.</p>				
<p>MINIMUM CLEARANCES TO COMBUSTIBLE MATERIALS / ESPACES LIBRES MINIMUM DES MATÉRIEAUX COMBUSTIBLES:</p>				
 <p>A Back Wall to stove / Mur Arrière du poêle</p>		<p>2"/51mm</p>		
 <p>B Side Wall to Cast Top / Mur De Côté du haut</p>		<p>6"/152mm</p>		
<p>CORNER INSTALLATION / NSTALLATION DU COIN :</p>				
 <p>C Side Wall / Mur De Côté</p>		<p>2"/51mm</p>		
<p>VERTICAL 3" - 6" ADAPTER KIT (PART 812-3570) INSTALLATION:</p> <p>UN ASSEMBLAGE POUR ADAPTEUR 3" - 6" (PIÈCE 812-3570) POUR INSTALLATION VERTICALE:</p>				
 <p>D Back Wall to Flue Pipe / Mur Arrière tuyau rigide</p>		<p>3"/76mm</p>		
 <p>E Side Wall to Cast Top / Mur De Côté du haut</p>		<p>6"/152mm</p>		
<p>CORNER INSTALLATION WITH VERTICAL ADAPTER KIT:</p> <p>INSTALLATION DU COIN AVEC UN ASSEMBLAGE D'ADAPTEUR VERTICAL:</p>				
 <p>F Side Wall / Mur De Côté</p>		<p>2"/51mm</p>		
<p>ALCOVE INSTALLATION / INSTALLATION DE L'ALCÔVE:</p> <p>Min. Alcove Height: / Une hauteur minimum de l'alcôve 43"/1092mm Min. Alcove Side Wall: / Une hauteur minimum mur de côté de l'alcôve 6"/152mm Max. Alcove Depth: / La profondeur maximum de l'alcôve 36"/914mm</p>				
<p>FLOOR PROTECTION / PROTECTION DU SOL</p>				
 <p>G = 2"/51mm H* = 2"/51mm I = 6"/152mm</p> <p>Mfg by/Fabriqué par:</p>		<p>*Non-combustible floor protection must extend beneath the flue pipe when installed with horizontal venting or under the Top Vent Adapter with vertical installation. *Un protecteur incombustible de plancher doit s'étendre sous le conduit de cheminée pour une installation de ventilation horizontale ou sous un adaptateur de ventilation de dessus pour une installation verticale. ÉTATS-UNIS - RECOMMANDÉ; CANADA - REQUIRMENT Le poêle doit être placé sur une assise non combustible s'étendant tout autour de lui, comme les schémas l'indiquent. Mesurez la distance du devant (I) de la surface de la porte vitrée.</p>		
<p>U.S. ENVIRONMENTAL PROTECTION AGENCY This model is exempt from EPA certification under 40 CFR 60.531 by definition [Wood Heater (A) "Air-to-Fuel Ratio"].</p>				
<p>2008 2009 2010 Jan. Feb. Mar. Apr. May June July Aug. Sept. Oct. Nov. Dec.</p>				
<p>1445 Highway North Colville, WA 99114 DO NOT REMOVE THIS LABEL / NE PAS ENLEVER L'ÉTIQUETTE Made in U.S.A./Fait États-Unis</p>				

Serial Number
Model Name
Test Lab & Report No.

Mfg. Date

TABLE OF CONTENTS**Section 1: Listing and Code Approvals**

- A. Appliance Certifications4
- B. Mobile Home Approved4
- C. Glass Specifications.....4
- D. Electrical Rating4
- E. BTU & Efficiency Specifications4

Section 2: Getting Started

- A. Design, Installation & Location Considerations.....5
- B. Fire Safety5
- C. Tools & Supplies Needed6
- D. Inspect Appliance & Components.....6

Section 3: Dimensions & Clearances

- A. Appliance Dimensions7
- B. Clearances to Combustibles8
- C. Hearth Requirements.....9

Section 4: Vent Information

- A. Chimney & Exhaust Connection 10
- B. Venting Termination Requirements 10
- C. Equivalent Feet of Pipe 11
- D. Pipe Selection Chart..... 11

Section 5: Venting Systems

- A. Alcove 12
- B. Through the Wall..... 13
- C. Vertical 14
- D. Through the Wall & Vertical 14
- E. Masonry 15
- F. Alternate Masonry 15

Section 6: Mobile Home 16**Section 7: Appliance Set-Up**

- A. Outside Air Kit..... 17
- B. Leg Leveling System..... 18
- C. Top Vent Adapter 18
- D. Rear Vent Adapter 18
- E. Log Set Placement..... 19
- F. Thermostat Installation.....20

Section 8: Operating Instructions

- A. Fuel Size & Material21
- B. General Operation Information21
- C. Before Your First Fire22
- D. Starting Your First Fire.....22
- E. Fire Characteristics.....22
- F. Feed Rate Adjustment Instructions.....22
- G. Ignition Cycles23
- H. Frequently Asked Questions.....22

Section 9: Troubleshooting24-26**Section 10: Maintaining & Servicing Appliance**

- A. Proper Shutdown Procedures27
- B. General Maintenance & Cleaning27-29
- C. High Ash Fuel Content Maintenance ..30
- D. Blower Replacement.....31
- E. Igniter Replacement.....32
- F. Baffle Removal.....32
- G. Glass Replacement.....33

Section 12: Reference Material

- A. Component Functions.....34-35
- B. Component Locations36
- C. Exploded Drawings.....37-38
- D. Service Parts & Accessories40-42
- E. Service & Maintenance Log43-44
- F. Homeowner's Notes.....45
- G. Warranty Policy46-47
- H. Contact Information.....48

1

Listing and Code Approvals

A. Appliance Certification

Model:	Castile Pellet Stove
Laboratory:	OMNI Test Laboratories, Inc.
Report No.	061-S-33-2
Type:	Solid Fuel Room Heater/Pellet Fuel Burning Type
Standard:	ASTM E1509-95, ULC S627-00 and ULC/ORD-C1482-M1990 Room Heater Pellet Fuel Burning type and (UM) 84-HUD, Mobile Home Approved.
State Listing:	State of Colorado

B. Mobile Home Approved

This appliance is approved for mobile home installations when not installed in a sleeping room and when an outside combustion air inlet is provided. The structural integrity of the mobile home floor, ceiling, and walls must be maintained. The appliance must be properly grounded to the frame of the mobile home and use only listed pellet vent Class "L" or "PL" connector pipe. A Quadra-Fire Outside Air Kit must be installed in a mobile home installation.

C. Glass Specifications

This appliance is equipped with 5mm ceramic glass. Replace glass only with 5mm ceramic glass. Please contact your dealer for replacement glass.

NOTE: This installation must conform with local codes. In the absence of local codes you must comply with the **ASTM E1509-95, ULC S627-00 ULC/ORD-C-1482-M1990 (UM) 84-HUD**

D. Electrical Rating

115 VAC, 60 Hz, Start 4.1 Amps, Run 1.1 Amps

E. BTU & Efficiency Specifications

Particulate Emissions Rating:	.7 grams/hr
*BTU Output:	8,000 - 30,000 / hr
Heating Capacity:	up to 1,500 sq. ft. depending on climate zone
Hopper Capacity:	40 lbs
Fuel:	Wood Pellets or Shelled Corn
Shipping Weight:	258 lbs

*BTU output will vary, depending on the brand of fuel you use in your stove. Consult your Quadra-Fire dealer for best results.

NOTE: Hearth & Home Technologies, manufacturer of this appliance, reserves the right to alter its products, their specifications and/or price without notice.

2

Getting Started

A. Design, Installation & Location Considerations

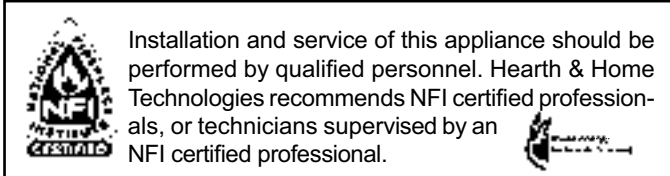

1. Appliance Location

Consideration must be given to safety, convenience, traffic flow, and the fact that the appliance will need a chimney and chimney connector. It is a good idea to plan your installation on paper, using exact measurements for clearances and floor protection, before actually beginning the installation.

If you are not using an existing chimney, place the appliance in a location to maintain a clear passage for the installation of any listed and approved pellet venting system. This appliance may be vented vertically or horizontally.

Maintain specified vent clearance to combustible requirements listed by the pellet manufacturer's venting instructions and all clearance to combustibles listed in this manual.

Check with your local building code agency before you begin your installation. Be sure local building codes do not supersede UL specifications and always obtain a building permit so that insurance protection benefits cannot be unexpectedly cancelled. If any assistance is required during installation, please contact your local dealer.

We recommend that a qualified building inspector and your insurance company representative review your plans before and after installation.

2. Thermostat Location

The thermostat's location will have some effect on the appliance's operation. When the thermostat is located close to the appliance, it may require a slightly higher temperature setting to keep the rest of the house comfortable. If the thermostat location is in an adjacent room or on a different floor level, you will notice higher temperatures near the appliance.

CAUTION

- Do NOT connect this unit to a chimney flue servicing another appliance.
- Do NOT connect to any air distribution duct or system.

B. Fire Safety



Maintain the designated clearances to combustibles. Insulation must not touch the chimney. You must maintain the designated air space clearance around the chimney. This space around a chimney is necessary to allow natural heat removal from the area. Insulation in this space will cause a heat buildup, which may ignite wood framing. **NOTE: Clearances may only be reduced by means approved by the regulatory authority having jurisdiction.**

To provide reasonable fire safety, the following should be given serious consideration:

1. Install at least one smoke detector on each floor of your home to ensure your safety. They should be located away from the heating appliance and close to the sleeping areas. Follow the smoke detector manufacturer's placement and installation instructions, and be sure to maintain regularly.
2. A conveniently located Class A fire extinguisher to contend with small fires resulting from burning embers.
3. A practiced evacuation plan, consisting of at least 2 escape routes.
4. A plan to deal with a hopper fire as follows:

In the event of a hopper fire:

- a. Evacuate the house immediately.
- b. Notify fire department.



 WARNING	
	<p>Fire Hazard.</p> <ul style="list-style-type: none"> • Do not operate appliance before reading and understanding operating instructions. • Failure to operate appliance properly may cause a house fire.
	



C. Tools And Supplies Needed

Tools and building supplies normally required for installation, unless installing into an existing masonry fireplace:	
Reciprocating Saw	Safety Glasses
Channel Locks	Framing Square
Hammer	Electric Drill & Bits (1/4")
Phillips Screwdriver	1/4" Self-Tapping Screws
Tape Measure	
Plumb Line	<u>May also need:</u>
Level	Vent Support Straps
Framing Material	Venting Paint
Hi-temp Caulking Material	
Gloves	

D. Inspect Appliance & Components and Pre-Use Check List

1.		Place the appliance in a location near the final installation area and follow the procedures below:
2.		Open the appliance and remove all the parts and articles packed inside the Component Pack. Inspect all the parts and glass for shipping damage. Contact your dealer if any irregularities are noticed.
3.		All safety warnings have been read and followed.
4.		This Owner's Manual has been read.
5.		Floor protection requirements have been met.
6.		Venting is properly installed.
7.		The proper clearances from the appliance and chimney to combustible materials have been met.
8.		The masonry chimney is inspected by a professional and is clean, or the factory built metal chimney is installed according to the manufacturer's instructions and clearances.
9.		The chimney meets the required minimum height.
10.		All labels have been removed from the glass door.
11.		Plated surfaces have been wiped clean, if applicable.
12.		Thermostat or remote has been installed.
13.		A power outlet is available nearby.

	 WARNING
<p>Inspect appliance and components for damage. Damaged parts may impair safe operation.</p> <ul style="list-style-type: none"> • Do NOT install damaged components. • Do NOT install incomplete components. • Do NOT install substitute components. <p>Report damaged parts to dealer.</p>	

	 WARNING
<p>Fire Risk.</p> <p>Hearth & Home Technologies disclaims any responsibility for, and the warranty will be voided by, the following actions:</p> <ul style="list-style-type: none"> • Installation and use of any damaged appliance. • Modification of the appliance. • Installation other than as instructed by Hearth & Home Technologies. • Installation and/or use of any component part not approved by Hearth & Home Technologies. • Operating appliance without fully assembling all components. • Operating appliance without legs attached (if supplied with unit). • Do NOT Overfire <p>Or any such action that may cause a fire hazard.</p>	

3 Dimensions and Clearances

A. Appliance Dimensions

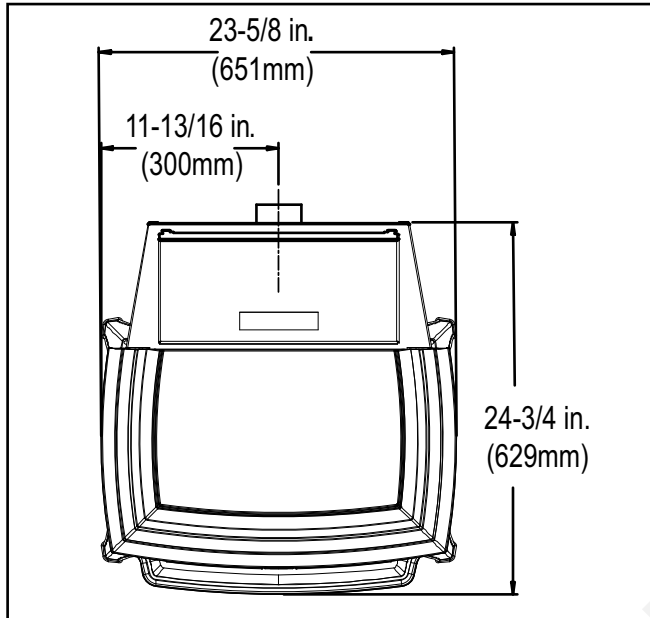

Figure 7.1 - Top View

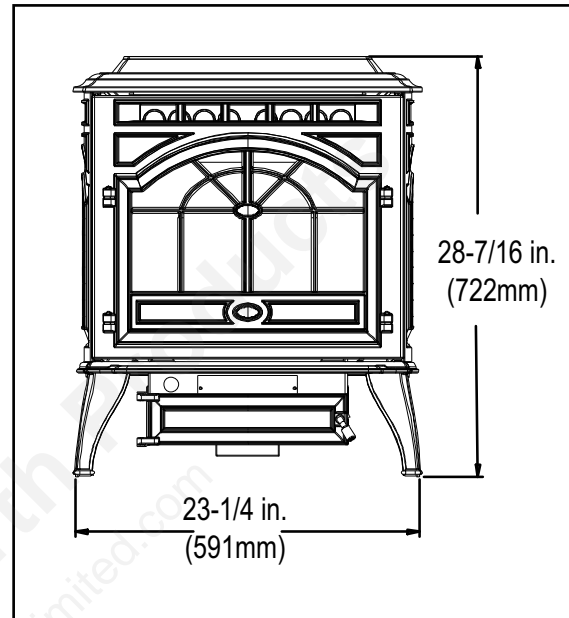

Figure 7.2- Front View

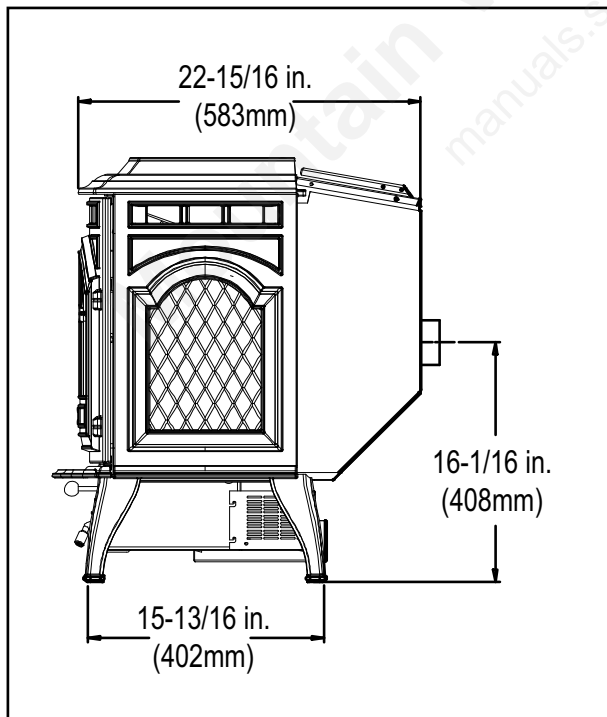

Figure 7.3 -Side View

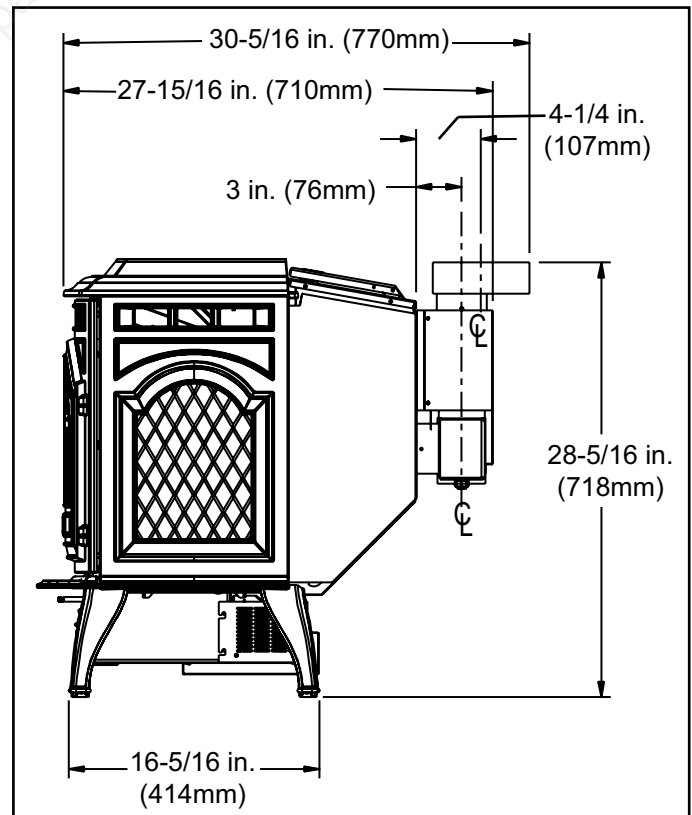
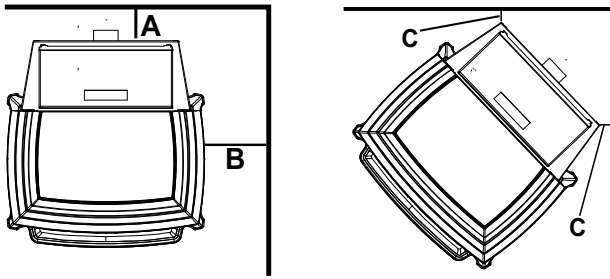

Figure 7.4 - Side View with Top Vent Adapter

B. Clearances to Combustibles (UL and ULC)



Straight Back Against Wall		Inches	Millimeters
A	Back Wall to Appliance	2	51
B	Side Wall to Appliance	6	152

Corner Installation		Inches	Millimeters
C	Walls to Appliance	2	51

Alcove Installation		Inches	Millimeters
Minimum Alcove Height		43	1092
Minimum Alcove Side Wall		6	152
Minimum Alcove Width		38	965
Maximum Alcove Depth		36	914

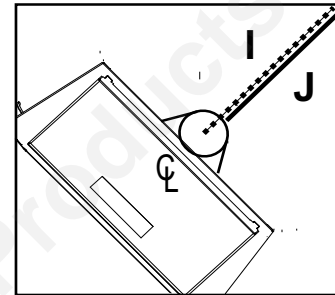

Dimension to Corner		Inches	Millimeters
I	Flue Center Line	10-3/8	264
J	Back of Top Vent Adapter	9-1/8	232

**Installations with:
3 to 3 inch Top Vent Adapter and
3 to 6 inch Offset Adapter Kit**

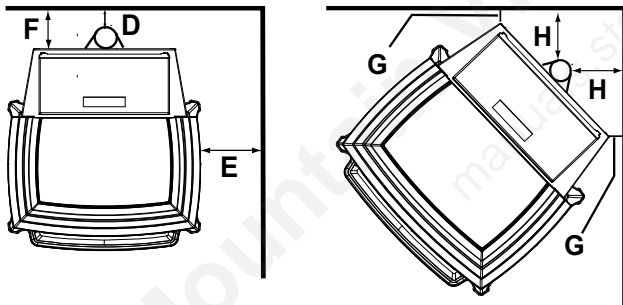

Vertical Installation		Inches	Millimeters
D	Back Wall to Flue Pipe	3	76
E	Side Wall to Cast Top	6	152
F	Back Wall to Appliance	8	203

Corner Installation		Inches	Millimeters
G	Walls to Appliance	2	51
H	Side Wall to Flue Pipe	3	76

WARNING

Fire Risk.
Comply with all minimum clearances to combustibles as specified.

Failure to comply may cause house fire.

NOTE:

- Illustrations reflect typical installations and are FOR DESIGN PURPOSES ONLY.
- Illustrations/diagrams are not drawn to scale.
- Actual installation may vary due to individual design preference.

C. Hearth Pad Requirements (UL and ULC)

Use a non-combustible floor protector, extending beneath appliance and to the front, sides and rear as indicated. Measure front distance "M" from the surface of the glass door.

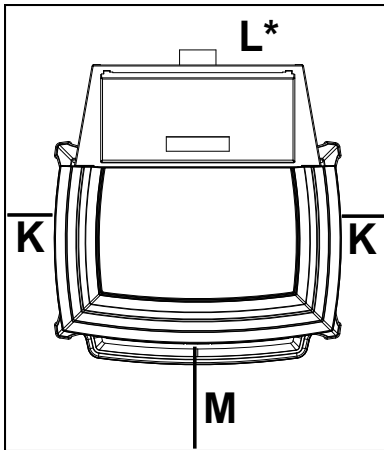

Hearth Pad Requirements		Inches	Millimeters
K	Sides	2	51
L*	Back	2	51
M	Front	6	152

***L Exception for Horizontal Installations:**

USA INSTALLATIONS: A non-combustible floor protection is recommended extending beneath the flue pipe when installed with horizontal venting or under the Top Vent Adapter with vertical installation.

CANADA INSTALLATIONS: A non-combustible floor protection extending beneath the flue pipe is **required** with horizontal venting or under the Top Vent Adapter with vertical installation.

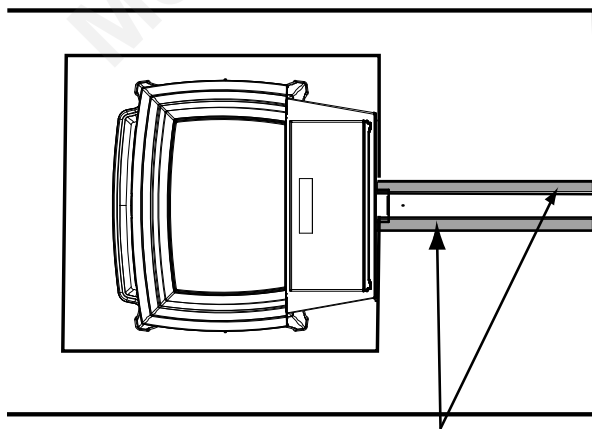

Must extend 2 inches (51mm) beyond each side of pipe (shaded area)

4 Vent Information

A. Chimney and Exhaust Connection

1. **Chimney & Connector:** Use 3 or 4 inch (76-102mm) diameter type "L" or "PL" venting system. It can be vented vertically or horizontally.
2. **Mobile Home:** Approved for all listed pellet vent. If using the 3 inch (76mm) vertical Top Vent Adapter Kit or the 3 to 6 inch (76-152mm) Top Vent Offset Adapter, use listed double wall flue connector. A Quadra-Fire Outside Air Kit must be used with manufactured home installations.
3. **Residential:** The 3 inch (76mm) vertical Top Vent Adapter Kit and the 3 to 6 inch (76-152mm) Top Vent Offset Adapter are tested to use 24 gauge single wall flue connector or listed double wall flue connector to Class A listed metal chimneys, or masonry chimneys meeting ICBO standards for solid fuel appliances.
4. **INSTALL VENT AT CLEARANCES SPECIFIED BY THE VENT MANUFACTURER.**
5. Secure exhaust venting system to the appliance with at least 3 screws. Also secure all connector pipe joints with at least 3 screws through each joint.

NOTE: All pipe must be welded seam pipe whenever possible. Seal pipe joints with high temperature silicone (500°F [260°C] minimum rated only).

NOTE: If burning shelled field corn, you must use approved venting specifically designed for corn. Follow the instructions from the venting manufacturer.

B. Venting Termination Requirements

CAUTION

Do not terminate vent in any enclosed or semi-enclosed area such as a carport, garage, attic, crawl space, under a sun deck or porch, narrow walkway or closely fenced area, or any location that can build up a concentration of fumes such as a stairwell, covered breezeway, etc.

1. Termination must exhaust above air inlet elevation. It is recommended that at least 60 inches (1524mm) of vertical pipe be installed when appliance is vented directly through a wall. This will create a natural draft, which will help prevent the possibility of smoke or odor venting into the home during a power outage. It will also keep exhaust from causing a nuisance or hazard by exposing people or shrubs to high temperatures. The safest and preferred venting method is to extend the vent vertically through the roof.
2. Distance from doors and opening windows, or gravity or ventilation air inlets into building:
 - a. Not less than 48 inches (1219mm) below;
 - b. Not less than 48 inches (1219mm) horizontally from;
 - c. Not less than 12 inches (305mm) above.
3. Distance from permanently closed windows:
 - a. Not less than 12 inches (305mm) below, horizontally from or above.
4. Distance between bottom of termination and grade should be 12 inches (305mm) minimum. This is conditional upon plants in the area, and nature of grade surface. The grade surface must be a noncombustible material (i.e., rock, dirt). The grade surface must not be lawn. Distance between bottom of termination and public walkway should be 84 inches (2134mm) minimum.
5. Distance to combustible materials must be 24 inches (610mm) minimum. This includes adjacent buildings, fences, protruding parts of the structure, roof overhang, plants and shrubs, etc.
6. Termination Cap Location (Home Electrical Service)
 - Side-to-side clearance is to be the same as minimum clearance to vinyl inside corners.
 - Clearance of a termination cap below electrical service shall be the same as minimum clearance to vinyl soffits.
 - Clearance of a termination cap above electrical service will be 12 inches minimum.
 - Location of the vent termination must not obstruct or interfere with access to the electrical service.



WARNING

Fire Hazard.

- Only LISTED venting components may be used.
- NO OTHER vent components may be used. Substitute or damaged vent components may impair safe operation.



WARNING

Vent surfaces get HOT, can cause burns if touched. Noncombustible shielding or guards may be required

C. Equivalent Feet of Pipe

The table below can help you calculate the equivalent feet of pipe which is a method used to determine pellet vent size. See Figure 11.1

WARNING

Improper installation, adjustment, alteration, service or maintenance can cause injury or property damage. Refer to the owner's information manual provided with this appliance. For assistance or additional information consult a qualified installer, service agency or your dealer.

Example of 3 Elbow-Rear Vent Termination Calculaton

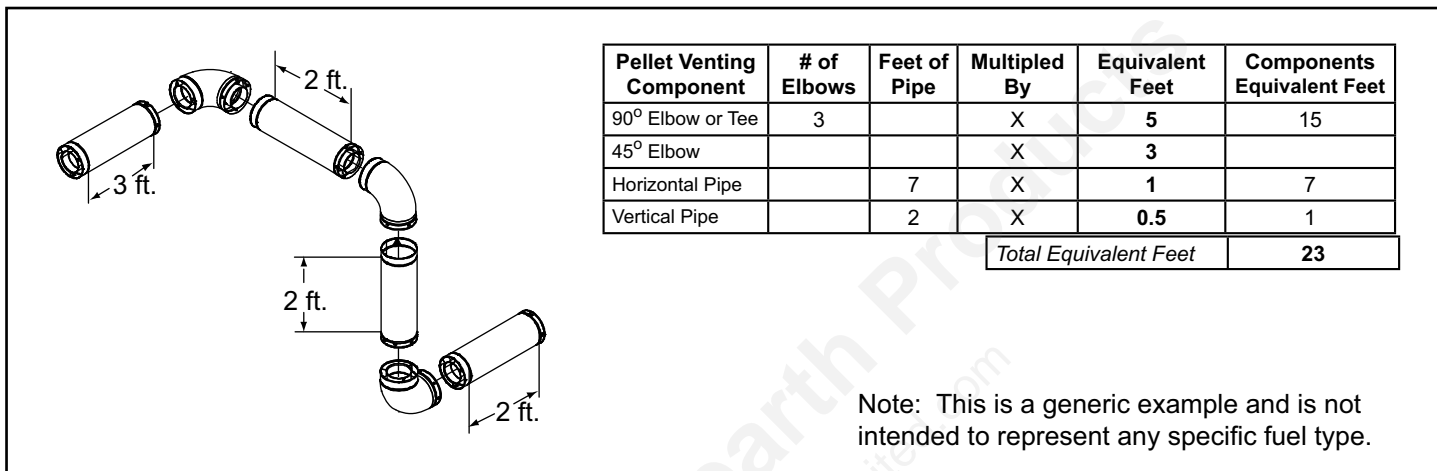

Note: This is a generic example and is not intended to represent any specific fuel type.

Figure 11.1

D. Pipe Selection Chart

The chart will help you in determining proper venting size according to the equivalent feet of pipe calculated above and the altitude above sea level of this installation. See Figure 11.2.

Locate the calculated equivalent feet of pipe on the vertical left side of the chart. Move to the right horizontally on the chart until you reach your altitude above sea level.

If you fall below the diagonal line, 3 or 4 inch (76 to 102mm) pipe may be used. If it is anywhere above the diagonal line, a 4 inch (102mm) diameter pipe is required.

The chart reveals that a 90° elbow is 5 times as restrictive to the flow of exhaust gases under positive pressure as 1 foot of horizontal pipe, and a foot of horizontal pipe is twice as restrictive as a foot of vertical pipe.

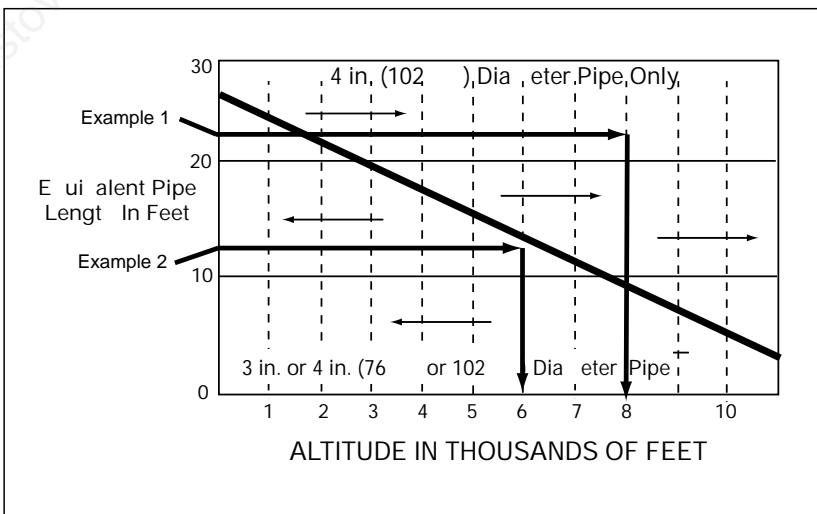

Figure 11.2

5 Venting Systems

A. Alcove

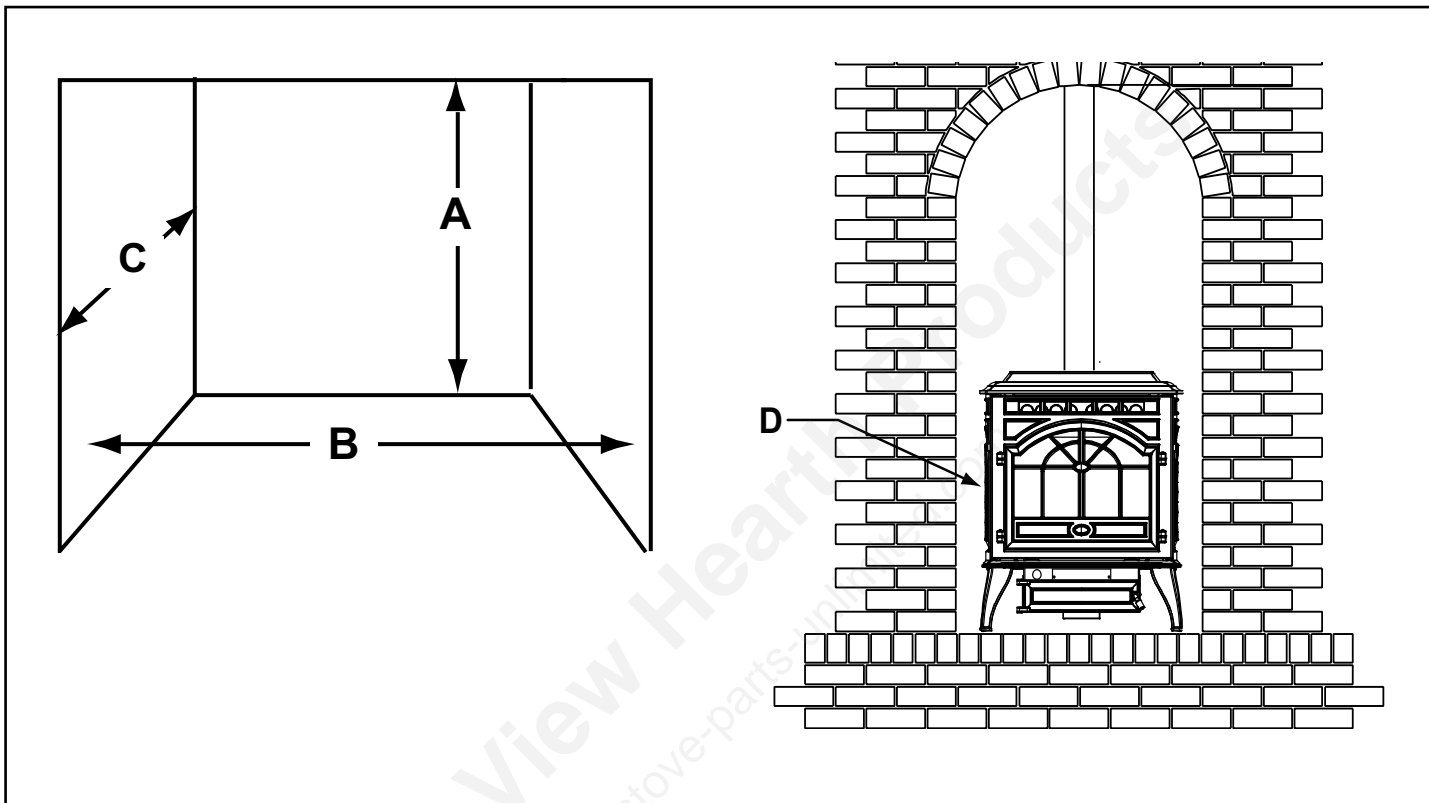

Figure 12.1

		Minimum		Maximum	
		Inches	Millimeters	Inches	Millimeters
A	Height	43	1092	n/a	n/a
B	Width	38	965	n/a	n/a
C	Depth	n/a	n/a	36	914
D	To Side Wall	6	152	n/a	n/a

All minimums listed are to a combustible surface.

NOTE:

- Illustrations reflect typical installations and are FOR DESIGN PURPOSES ONLY.
- Illustrations/diagrams are not drawn to scale.
- Actual installation may vary due to individual design preference.

B. Through The Wall

Horizontal termination cap must be a minimum of 12 inches (305mm) from the wall. Approved for mobile home installations. Must use 3 or 4 inch (76-102mm) "L" or "PL" listed pellet venting or listed double wall pipe and a Quadra-Fire Outside Air Kit in mobile homes.

NOTE:
In Canada, where passage through a wall or partition of combustible construction is desired, the installation shall conform to CAN/CSA-B365

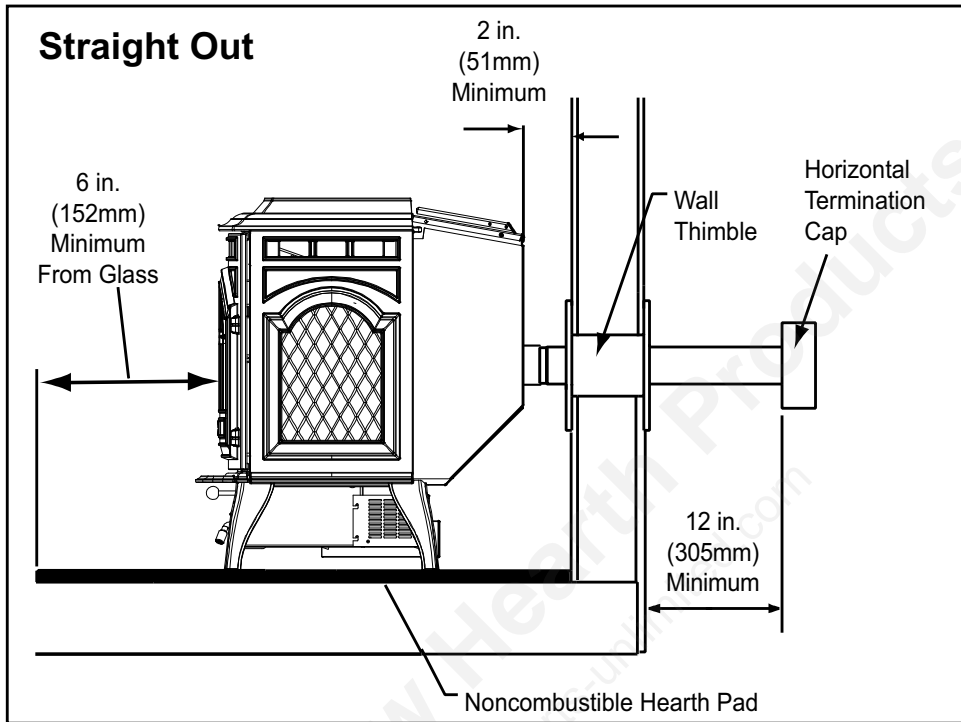

Figure 13.1

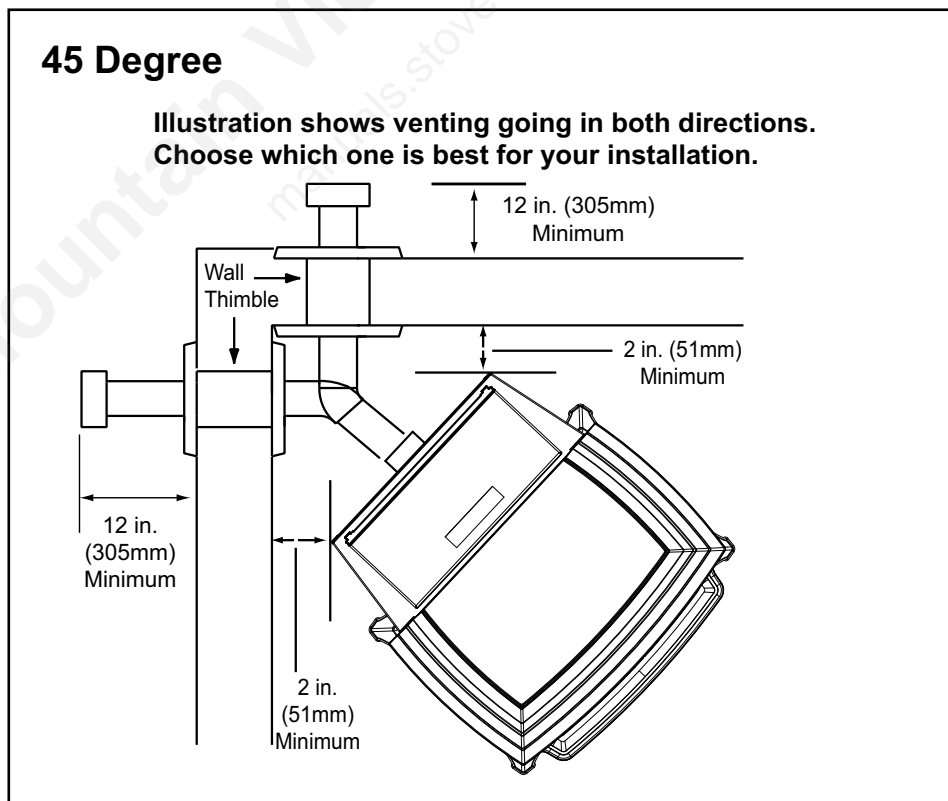
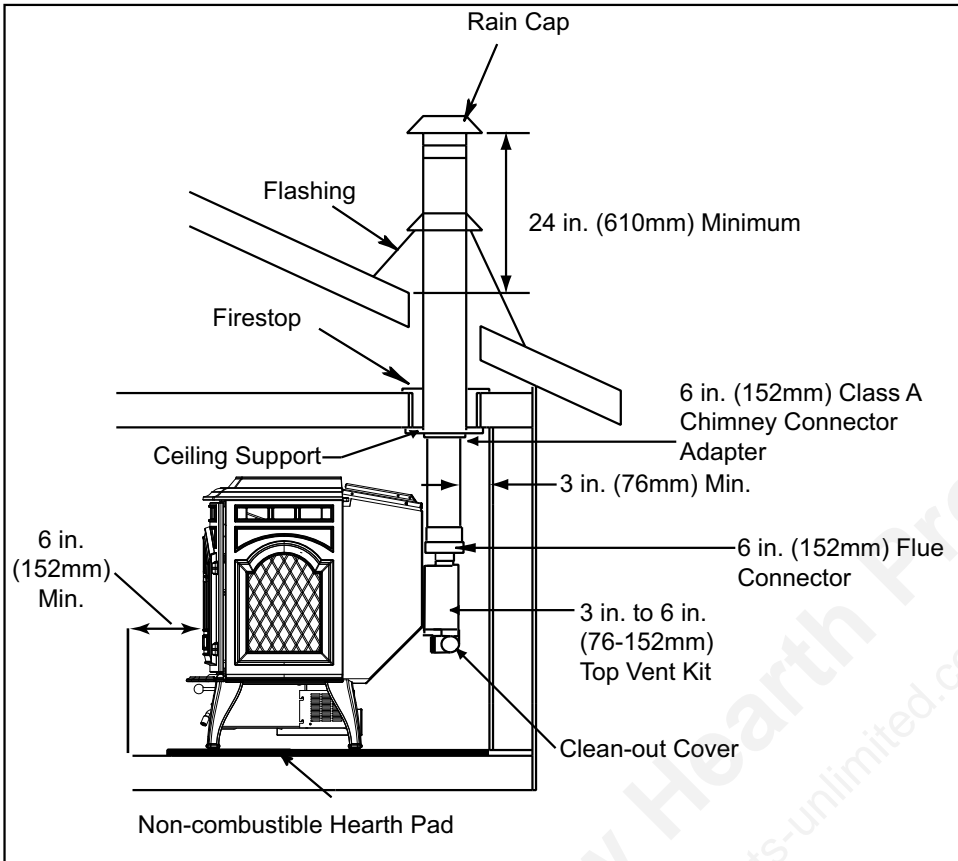

Figure 13.2

C. Vertical



We recommend a minimum of 60 in. (1524mm) vertical, however above the eave is preferred.

Both installations are approved for mobile home installations. Must use 3 or 4 inch (76 to 102mm) "L" or "PL" listed pellet venting or listed double wall pipe and Quadra-Fire Outside Air Kit in mobile homes. Single wall pipe is approved for residential installations only.

Figure 14.1

D. Through The Wall & Vertical

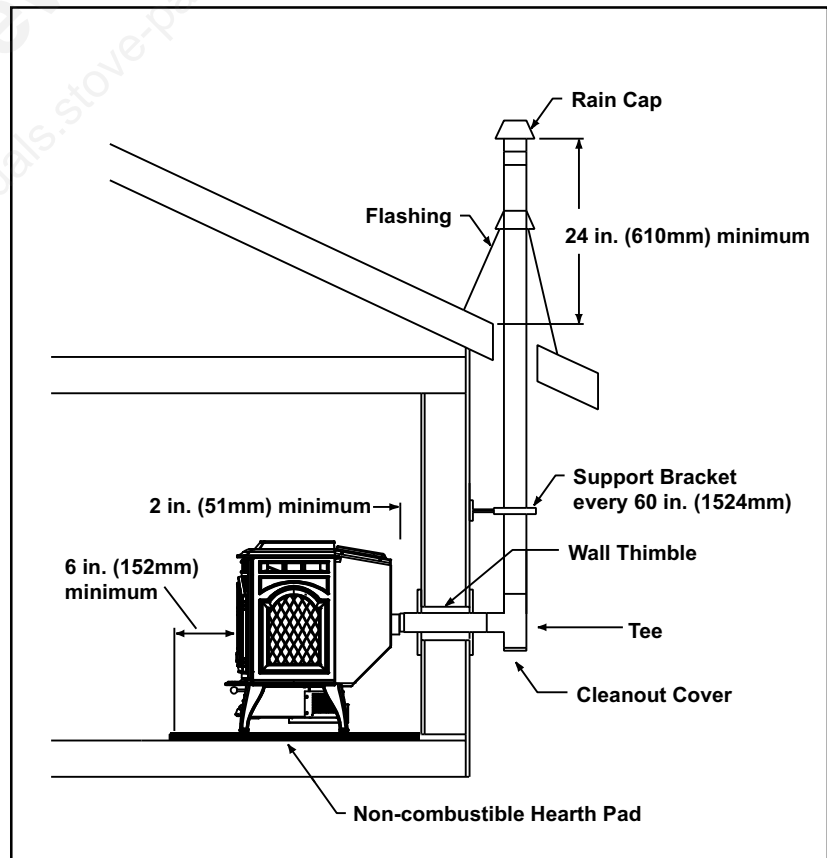



Figure 14.2



WARNING



Fire Hazard

Inspection of Chimney:

- Masonry chimney must be in good condition.
- Meets minimum standard of NFPA 211
- Factory-built chimney must be 6 in. (152mm) UL103 HT.

E. Masonry

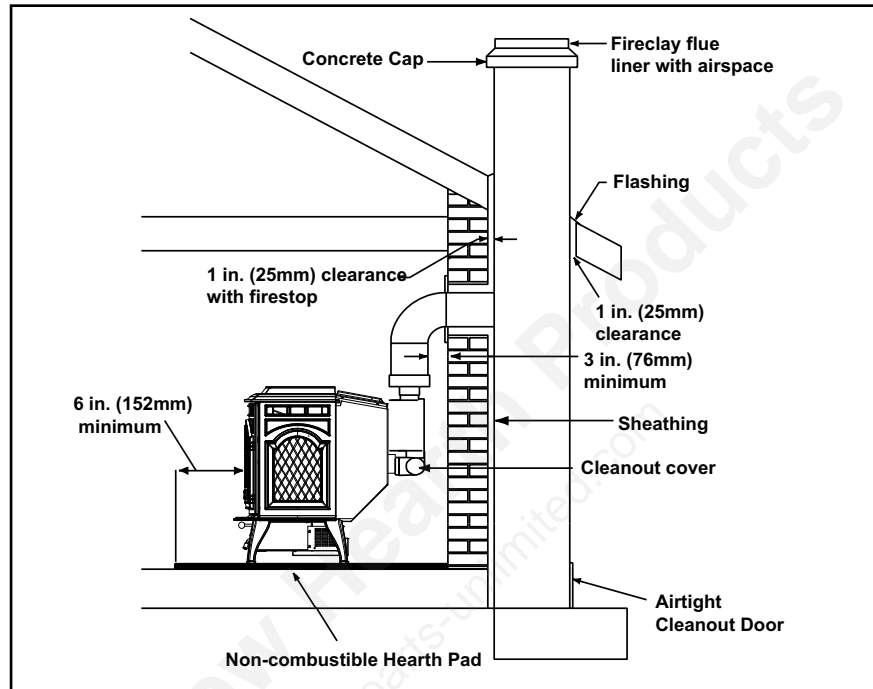

Figure 15.1

F. Alternate Masonry

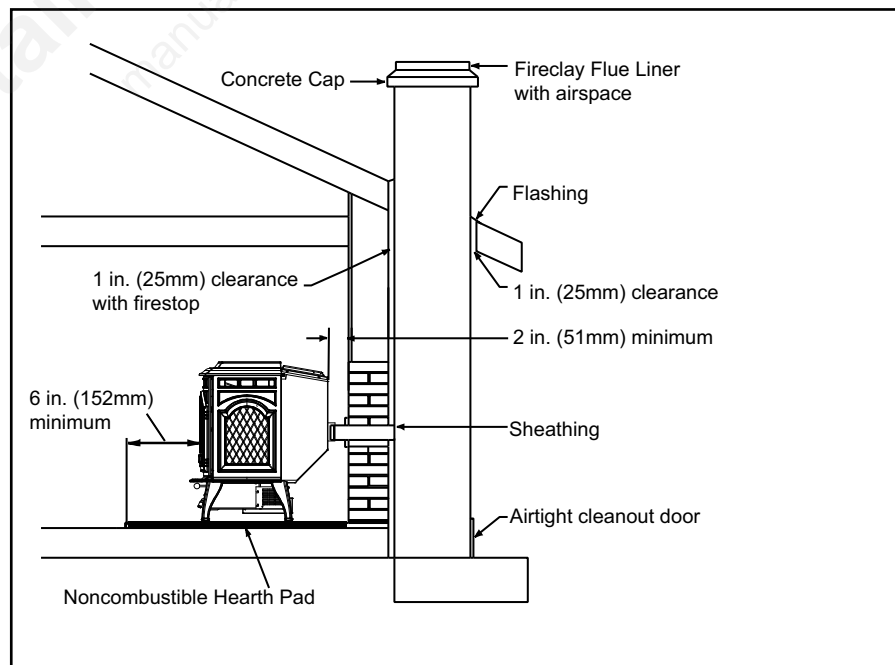

Figure 15.2

6 Mobile Home

A. Mobile Home Installation

You must use a Quadra-Fire Outside Air Kit for installation in a mobile home.

1. An outside air inlet must be provided for the combustion air and must remain clear of leaves, debris, ice and/or snow. It must be unrestricted while the appliance is in use to prevent room air starvation which causes smoke spillage. Smoke spillage can also set off smoke alarms.
2. The combustion air duct system must be made of metal. It must permit zero clearance to combustible construction and prevent material from dropping into the inlet or into the area beneath the dwelling and contain a rodent screen.
3. The appliance must be secured to the mobile home structure by bolting it to the floor (using lag bolts). Use the same holes that secured the appliance to the shipping pallet.
4. The appliance must be grounded with #8 solid copper grounding wire or equivalent, terminated at each end with an NEC approved grounding device.
5. Refer to clearances to combustibles and floor protection requirements on **pages 8 & 9** for listings to combustibles and appropriate chimney systems.
6. Use silicone to create an effective vapor barrier at the location where the chimney or other component penetrates to the exterior of the structure.
7. Follow the chimney manufacturer's instructions when installing the vent system for use in a mobile home.
8. Installation shall be in accordance with the Manufacturers Home & Safety Standard (HUD) CFR 3280, Part 24.

CAUTION
Maintain structural integrity of mobile home: <ul style="list-style-type: none"> • Floor, wall, ceiling and/or roof. Do NOT cut through: <ul style="list-style-type: none"> • Floor joist, wall, studs or ceiling trusses. • Any supporting material that would affect the structural integrity.

CAUTION
Never draw outside combustion air from: <ul style="list-style-type: none"> • Wall, floor or ceiling cavity • Enclosed space such as an attic or garage

 WARNING
Installation must comply with Manufactured Home and Safety Standard (HUD), CFR 3280, Part 24.

 WARNING
Never install in a sleeping room.

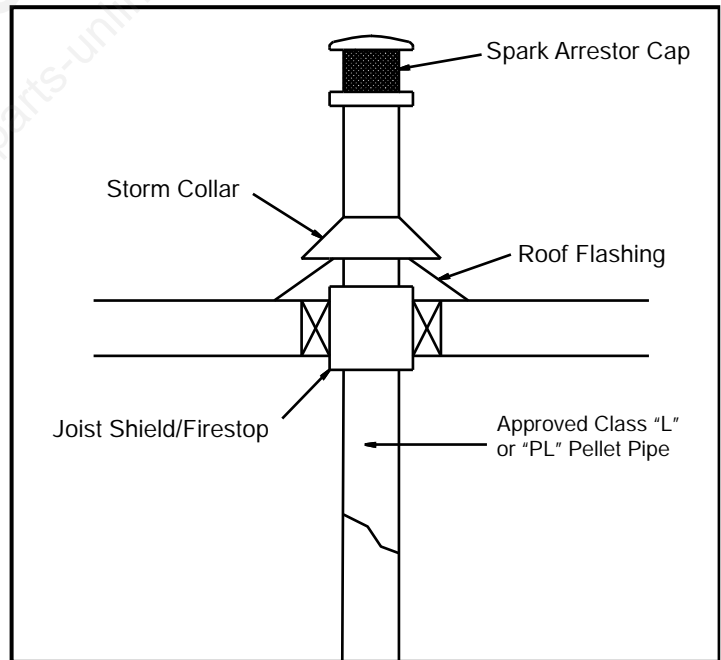

Figure 16.1

7 Appliance Set-Up

A. Outside Air Kit Instructions

Parts Included in Kit: 1 piece of 2 inch x 3 foot flex hose, 2 hose clamps, 1 collar assembly, 1 termination cap assembly, 1 trim ring, 12 screws.

Tools Needed: Phillips headscrewdriver; wire cutters; hole saw or jig saw.

1. **Figure 17.1** shows bottom of convection blower mount and pre-cut air vent opening for reference only. Air channel should be mounted with stove in upright position.
2. Align hooks in air channel with slots in convection blower mount and ash box, **Figure 17.2**. Push up and slide forward.
3. Secure air channel to appliance with 2 screws and secure the collar assembly to the air channel with 2 screws. **Figure 17.3**.

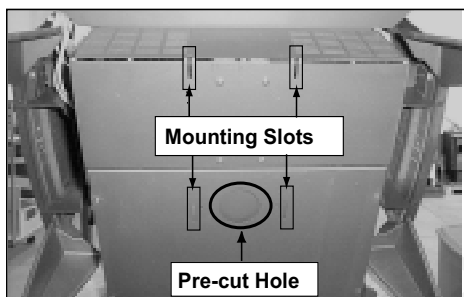

Figure 17.1

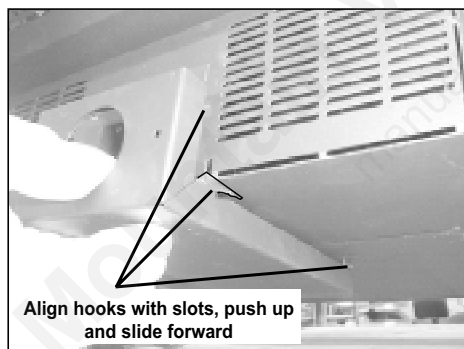

Figure 17.2

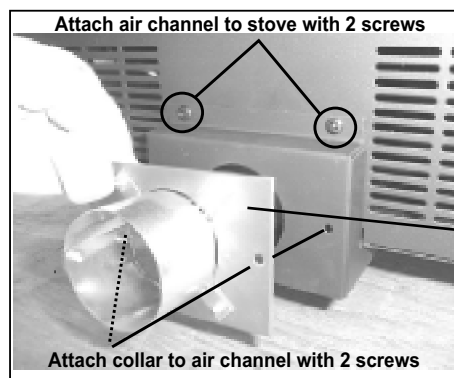

Figure 17.3

CAUTION

Never draw outside combustion air from:

- Wall, floor or ceiling cavity
- Enclosed space such as an attic or garage

1. Measure distance from floor to air vent opening in appliance and mark location on wall.
Use saw to cut opening in wall. Cut a 2-1/2 to 3 inch (64-76mm) opening on inside wall and a 3 to 3-1/2 inch (76-89mm) opening on outside of house.
2. Use hose clamp to secure flex pipe to collar assembly.
3. Slide trim ring over flex pipe and run pipe through wall.
4. Attach hose to outside termination cap with second hose clamp.
5. Secure termination cap to outside surface.
6. Secure trim ring to interior wall.

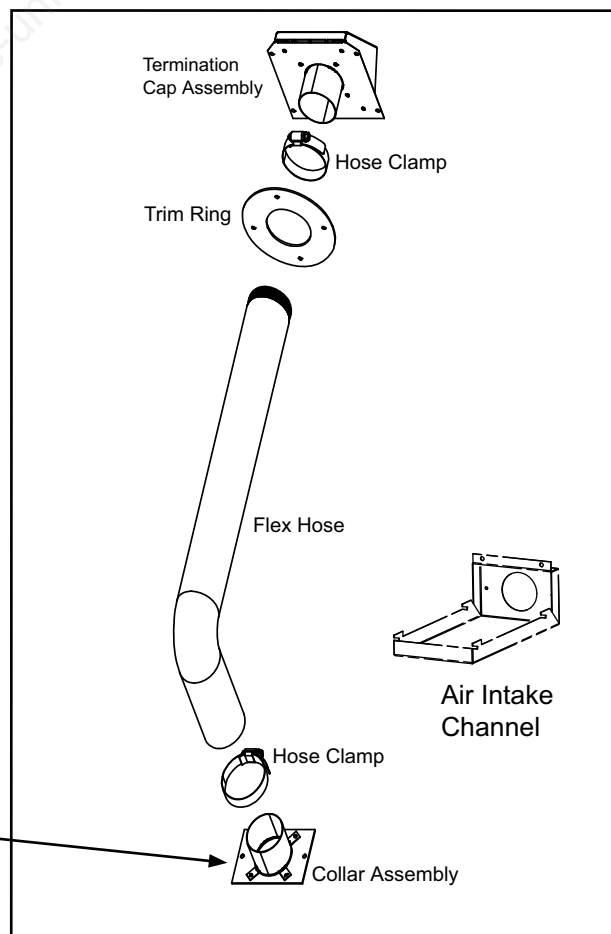

Figure 17.4

B. Leg Leveling System

1. Thread Allen bolts through nuts until flush. **Figure 18.1.** The Allen bolts and nuts are included in the component pack inside the stove firebox.
2. Slide assembled nuts and bolts into slots on legs with the nuts on the bottom. **Figure 18.2.** Use a 5/32 in. (3.96mm) Allen wrench to adjust legs up and down to desired level. **Figure 18.3**

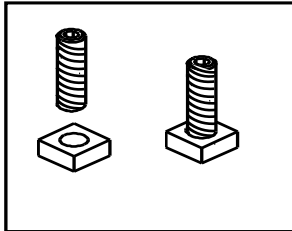

Figure 18.1

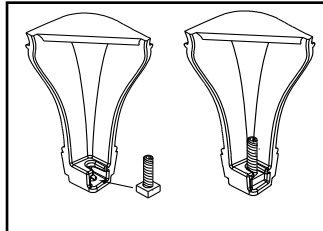

Figure 18.2

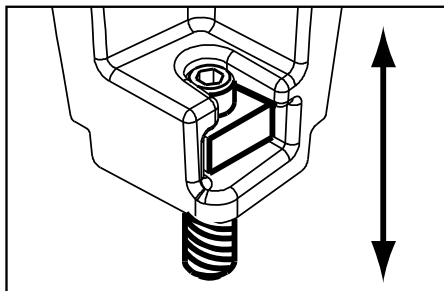

Figure 18.3 - Bolt fully extended

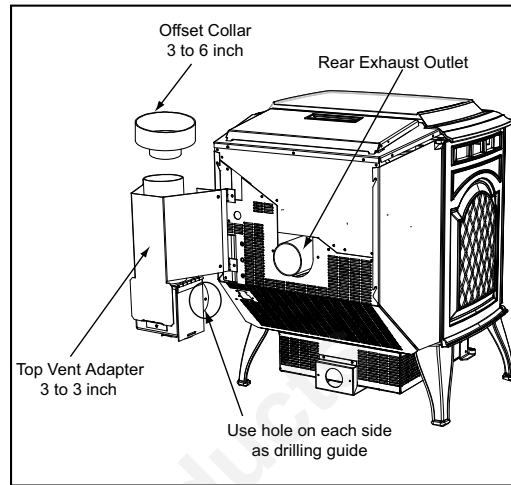

Figure 18.4

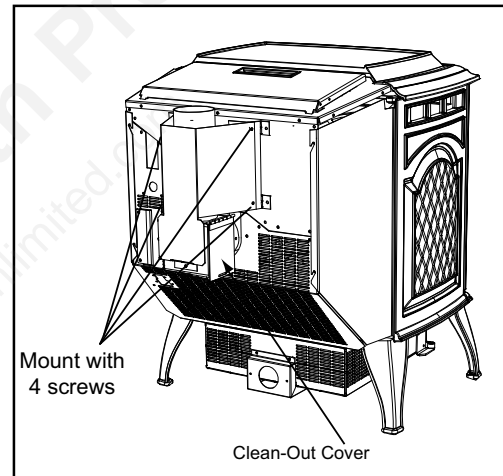

Figure 18.5

C. Top Vent Adapter Installation

- 3 to 3 inch Top Vent Adapter
- 3 to 6 inch Top Vent Offset Adapter

Installing the Top Vent Adapter

1. Put a layer of high temperature silicone on the 3 inch (76mm) rearexhaust outlet. **Figure 18.4**
2. Slide the top vent adapter onto the rear exhaust outlet and adjust the assembly to a vertical position. **Figure 18.4**
3. Drill 4 holes with #26 drill bit (provided) into the back of the appliance using the outer shield as a pattern (make sure the assembly is vertical). **Figure 18.4**
4. Install the 4 mounting screws.
5. Drill 2 holes with #26 drill bit through the rear exhaust outlet using the 2 holes already in the short horizontal pipe in the top vent adapter as a guide. Install the 4 screws. **Figure 18.5.**
6. Install the vent pipe into the top vent adapter (be sure to silicone all joints).

D. Rear Vent and Rear Vent to Top Vent Adapter Installation

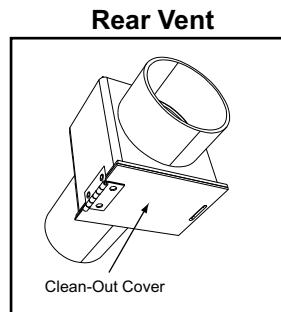

Figure 18.6

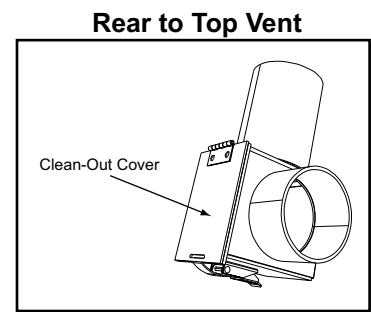

Figure 18.7

1. Put a layer of high temperature silicone on the 3 inch (76mm) exhaust outlet. **Figure 18.4**
2. Slide the adapter onto the rear exhaust outlet and adjust the assembly to the appropriate position.
3. Install the vent pipe into the adapter (be sure to silicone all joints)

E. Optional Log Set Placement Instructions

CAUTION

Logs are FRAGILE. Use extreme care when handling or cleaning logs.

4 PIECE LOG SET INSTALLATION

1. Open the hinged cast face and open the glass door assembly.
2. To position the logs, place the right rear log as shown in **Figure 19.1**. There is a notch in the bottom of the log for clearance for the thermocouple and thermocouple cover (ceramic protection tube).
3. Continue placing the last 3 logs around the firepot as show in **Figures 19.2, 19.3 and 19.4**. Be careful not to block the drop tube in the back of the firebox where pellets feed into the firepot.

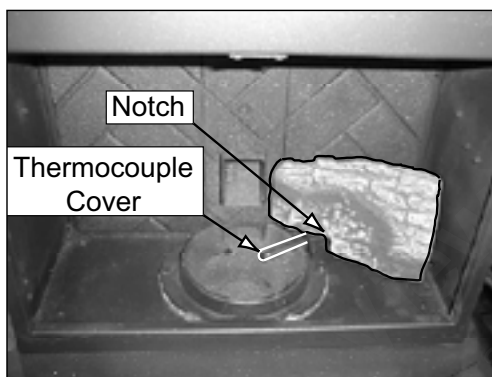

Figure 19.1

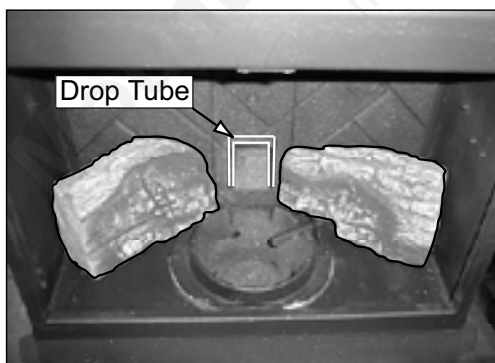

Figure 19.2

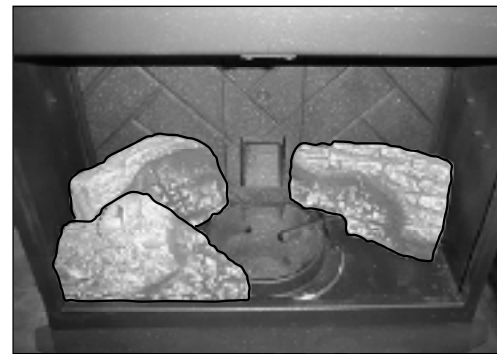

Figure 19.3

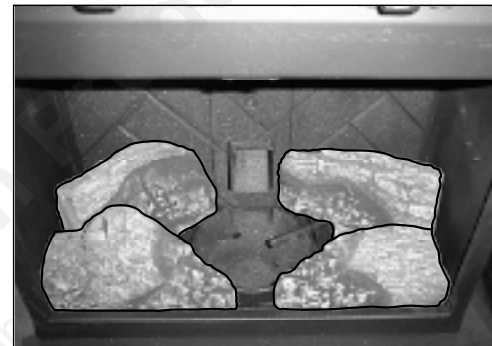

Figure 19.4

OPTIONAL TOP LOG

Place the log over the firepot. The charred area on the back of the log is turned toward the back, not the front.

The log will be about 2-1/2 inches above the firepot when in place. It must rest on the 3 logs in a stable position to prevent it from falling into the firepot.

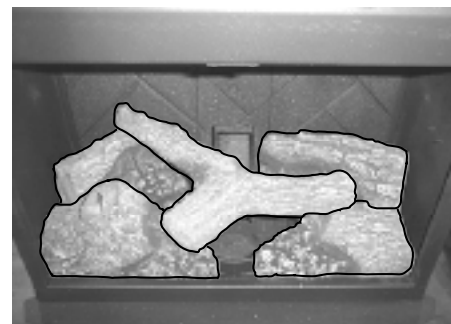

Figure 19.5

NOTE:

Due to the abrasive nature of a pellet appliance fire, the logs are not covered under warranty. Any placement variation other than shown here can cause excessive heat and shall void the appliance warranty.



F. Thermostat Installation

1. A 12 volt AC thermostat is required to operate this pellet appliance. You may use the included wall mount thermostat or purchase an optional programmable thermostat or remote control. It is equipped with an adjustable heat anticipator. The current rating is .05 amps. The anticipator needs to be adjusted to the lowest setting available.
2. When mounting a thermostat on a wall, be sure to follow your thermostat installation instructions carefully.

NOTE: Thermostat must be mounted level for accurate readings. The thermostat should be mounted on an inside wall and not in direct line with the appliance convection air.

NOTE: If the thermostat is located too close to the appliance, you may need to set the temperature setting slightly higher to maintain the desired temperature in your home.

3. There is a 4 screw terminal block located on the back lower right corner of the stove directly above the power cord inlet. The center 2 screws are for the thermostat wires.

	<p>CAUTION</p>
	<p>Shock hazard.</p> <ul style="list-style-type: none"> • Do NOT remove grounding prong from plug. • Plug directly into properly grounded 3 prong receptacle. • Route cord away from appliance. • Do NOT route cord under or in front of appliance.

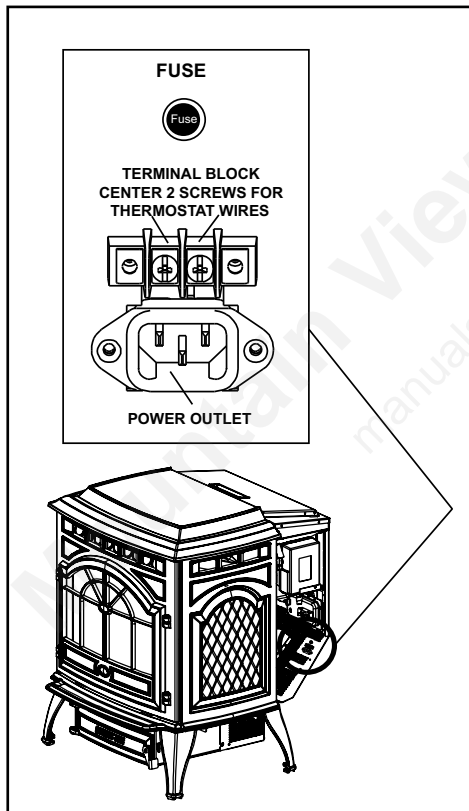

Figure 20.1

8 Operating Instructions

A. Fuel Size And Material

1. Wood Pellets

Fuel pellets are made from sawdust or wood by-products. If the source material is hardwood, they can have a higher mineral content, creating more ash. Fuels containing bark will also have higher ash content. Minerals and other noncombustible materials such as sand will turn into a hard, glass-like substance called a clinker when heated to the extreme temperatures our firepot reaches. This is what forms clinkers in the bottom of the firepot. Trees from different areas will vary in mineral content. That is why some fuels produce more clinkers than others. Pellets are manufactured in either 1/4 inch or 5/16 inch (6-8mm) diameter and should be **no more than 1-1/2 inches (38mm) in length**. Pellet lengths may even vary by lot from the same manufacturer which is why the feed rate may need to be adjusted occasionally. **If you burn pellets longer than 1-1/2 inches (38mm) you may have an inconsistent fuel feed rate and/or missed ignitions.**

Pellet fuel quality can greatly fluctuate. We recommend using premium grade fuel with ash content less than 1%. Even in some fuel labeled "premium" ash content can vary from bag to bag and possibly exceed 1%. High ash fuel, or lack of maintenance, can cause the firepot to fill up and thus create a potential for smoking, sooting and possible hopper fires.

Always burn dry fuel. Burning fuel with high moisture content takes heat from the fuel and tends to cool the appliance, robbing heat from your home. Damp pellet fuel can clog the feed system.

We recommend that you buy fuel in multi-ton lots whenever possible. Buying large quantities of fuel at once will greatly reduce the number of times the feed adjustments will need to be made. However, we do recommend trying various brands before purchasing multi-ton lots to ensure your satisfaction.

WARNING

Fire and Smoke Risk.

- High ash fuels or lack of maintenance can cause firepot to overfill. Follow proper shutdown procedure if ash buildup exceeds half way point in firepot.
- Failure to do so could result in smoking, sooting and possible hopper fires.

2. Shelled Field Corn

Extensive factory and field testing has demonstrated shelled field corn to be an efficient and very economical fuel. We recommend the use of a 50-50 blend of corn and wood pellets. The only change in operation is that the feed rate may require a slight adjustment. The BTU output of the appliance varies slightly compared to pellets, depending on the quality of the corn used. In cases where it is acceptable for the appliance to run full time, 100% corn will work after the fire has been started using wood pellets.

B. General Operating Information

1. Thermostat Calls For Heat

The appliance is like most modern furnaces; when the thermostat calls for heat, your appliance will automatically light and deliver heat. When the room is up to temperature and the thermostat is satisfied, the red call light will go off and the appliance will shut down.

2. Heat Output Controls

This appliance is equipped with a heat output control switch that has three settings or burn rates; low, medium and high. The appliance will turn on and off as the thermostat demands. When the thermostat calls for heat, the appliance will start up at the burn rate for which it is set. If the appliance is set at one of the lower settings, it will run quieter but take longer to heat up an area than if it were set at a higher burn rate. Regardless of the burn rate, when the area is warm enough to satisfy the thermostat, the appliance will shut off.

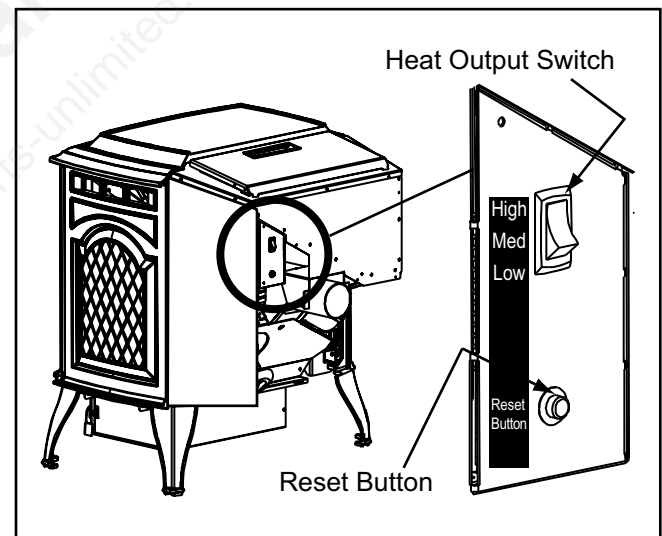

Figure 21.1

WARNING

Fire Hazard.

Keep combustible materials, gasoline and other flammable vapors and liquids clear of appliance.

- Do NOT store flammable materials in the appliance's vicinity.
- Do NOT use gasoline, lantern fuel, kerosene, charcoal lighter fluid or similar liquids to start or "freshen up" a fire in this heater.
- Keep all such liquids well away from the heater while it is in use.
- Combustible materials may ignite.

C. Before Your First Fire

1. First, make sure your appliance has been properly installed and that all safety requirements have been met. Pay particular attention to the fire protection, venting and thermostat installation instructions.
2. Double check that the ash pan and firebox are empty!
3. Check the position of the thermocouple, located above the firepot, and make sure that it protrudes approximately 3/4 inch (19mm) into the firepot. **IMPORTANT DETAIL: The tip of the thermocouple must be in contact with the inside end of the thermocouple cover.**
4. Close the front door.

D. Starting Your First Fire

1. A thermostat is required for proper operation of this appliance, except for corn. At this time, fill the hopper with pellets, set the thermostat to its lowest setting. Plug the power cord into nearby outlet.
2. The exhaust blower will stay on for approximately 18 minutes even though the thermostat is not calling for heat. This is normal.
3. Locate the heat output control switch mounted on the back of the appliance in the upper right corner. **See Figure 21.1 on page 21.** Turn it to the "high" setting by pushing the top of the control switch in and then adjust the thermostat to its highest setting. Open the right side panel and the red call light located behind the control box will be on. **See Figure 22.1.** This indicates the thermostat is calling for heat.
4. The fuel feed system and the igniter should now be on.
5. For your first fire it will be necessary to press the reset button once approximately 2 minutes after start up and again in 5 minutes. This will fill the feed system and allow the appliance to begin dropping pellets. The appliance will continue to run as long as the thermostat is calling for heat.
6. Once the appliance has ignited, let it burn for approximately 15 minutes, then set the thermostat to the desired room temperature. Adjust the heat output control switch to the desired setting.

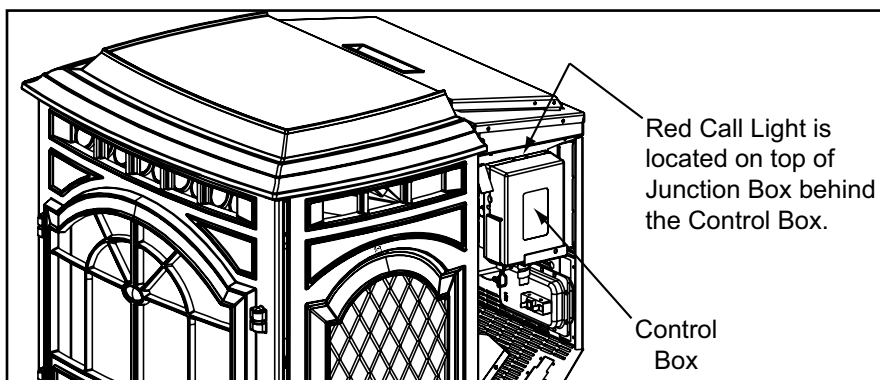

Figure 22.1

E. Fire Characteristics

A properly adjusted fire with the heat output control switch set on "high" has a short active flame pattern that extends out of the firepot approximately 4 inches (102mm). If the fire has tall flames with black tails and seems somewhat lazy, the feed rate will need to be reduced. This is done by sliding the fuel adjustment control rod down, which will reduce the feed. If the fire is not 4 inches (102mm) tall, slide the fuel adjustment control rod up to increase the feed. A medium and low setting will give a shorter flame. The flame will rise and fall somewhat. This is normal.

F. Feed Rate Adjustment Instructions

The feed adjustment control rod is factory set, and should be adequate for most fuels. However, if the flame height is too high or too low, you will need to adjust the feed rate. Wait until the appliance has been burning for 15 minutes before making your adjustments and allow 15 minutes for feed adjustment to take effect.

1. Loosen the set screw 1/4 to 1/2 turn during set-up of appliance. This will allow movement of the feed adjustment control rod. Do not re-tighten set screw. **Figure 22.2.**
2. Loosen the wing nut. **Figure 22.3.**
3. Adjust the feed adjustment control rod upward towards the "+" symbol to increase the feed rate and flame height or down towards the "-" symbol, to decrease the feed rate and flame height. **Figure 22.3.**
4. Re-tighten the wing nut.

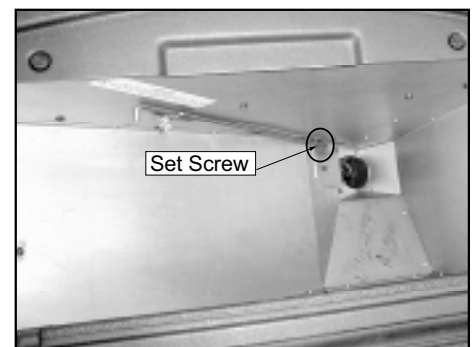

Figure 22.2

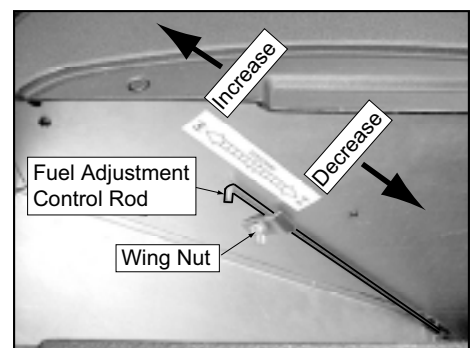

Figure 22.3

G Ignition Cycles

1. During each ignition cycle, it is normal to see some smoke in the firebox. The smoke will stop once the fire starts.
2. The convection blower will automatically turn on after your appliance has reached the set temperature on the "high" setting. This blower transfers heat from your appliance into the room, and will continue to run after the thermostat has stopped calling for heat until the appliance has cooled down.
3. Occasionally the appliance may run out of fuel and shut itself down. When this happens, the red call light will be on. (See Figure 22.1, page 22). To restart it, fill the hopper and press the reset button. (See Figure 21.1, page 21). When you press the reset button the red call light will go out. Release the button and the light will come back on. You should see a fire shortly. If not, follow the instructions on page 22, of "Starting Your First Fire".

CAUTION

Odors and vapors released during initial operation.

- Curing of high temperature paint.
- Open windows for air circulation.

Odors may be irritating to sensitive individuals.

WARNING



Fire Risk

Do NOT operate appliance:

- With appliance door open.
- Firepot floor open.
- Cleaning slide plates open.

Do NOT store fuel:

- Closer than required clearances to combustibles to appliance
- Within space required for loading or ash removal.

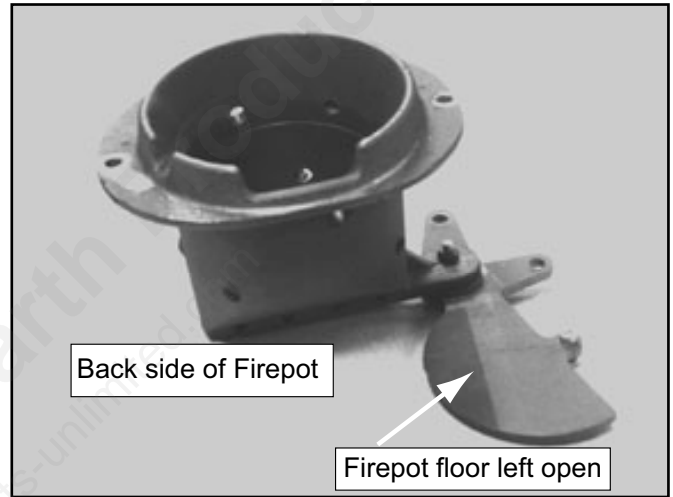

Figure 23.1 - DO NOT LEAVE FIREPOT FLOOR OPEN

H. Frequently Asked Questions

ISSUES	SOLUTIONS
1. Metallic noise.	1. Noise is caused by metal expanding and contracting as it heats up and cools down, similar to the sound produced by a furnace or heating duct. This noise does not affect the operation or longevity of your appliance.
2. Ash buildup on glass.	2. This is normal. Clean the glass.
3. Glass has turned dirty.	3. Excessive build up of ash. The lower burn settings will produce more ash, the higher burn settings produce less. The more it burns on low the more frequent cleaning of the glass is required.
4. Fire has tall flames with black tails and is lazy.	4. The feed rate needs to be reduced or the firepot needs cleaning. Heat exchanger or exhaust blower needs cleaning.
5. Smokey start-up or puffs of smoke from the airwash.	5. Either the firepot is dirty or there is too much fuel at start-up and not enough air. Close down feed rate 1/4 inch at a time until this no longer happens.
6. Large flame at start-up.	6. This is normal. Flame will settle down once the fire is established.

9 Troubleshooting

With proper installation, operation, and maintenance your appliance will provide years of trouble-free service. If you do experience a problem, this troubleshooting guide will assist a qualified service person in the diagnosis of a problem and the corrective action to be taken. This troubleshooting guide can only be used by a qualified service technician.

Symptom	Possible Cause	Corrective Action
Plug in appliance - No response.	No current to outlet. .7 amp fuse defective. #3 snap disc tripped or defective. Control box defective.	Check circuit breaker at service panel. Replace fuse. Reset or replace snap disc. Replace control box.
Call light on. No fire. No fuel in firepot.	Out of fuel. #2 snap disc may be defective. Vacuum switch not closing, no vacuum. Control box defective.	Check hopper. Fill with fuel. Replace snap disc. Check exhaust blower is plugged in and operating. Check vacuum switch is plugged in. Check vacuum hose is in good condition, clear and connected at both ends. Check thermocouple is in good condition and plugged in properly. Make sure venting system is clean. Make sure front door is closed. Replace control box.
Call light on. No fire. Partially burned fuel in firepot.	Firepot clean-out plate not closed. Firepot is dirty (missed ignition).	Check that firepot clean-out plate is fully closed. Clean firepot. Make sure there is no clinker in the firepot. Clinkers may have to be broken up with firepot scraper tool or other means.
Call light on. No fire. Unburned pellets in firepot.	Firepot clean-out plate not closed. Firepot is dirty. Ignition hole blocked. Igniter not working. Control box defective.	Check that firepot clean-out plate is fully closed. Clean firepot. Make sure there is not a clinker in the firepot. Clinkers may have to be pushed out of firepot with firepot scraper tool or other means. Scrape with solid piece of wire. Remove ash pan to see if igniter is glowing red on start-up. Check igniter wires for good connection. Replace igniter using 1/4 inch male /female spade connectors. Replace control box.
Slow or smoky start-up.	Firepot clean-out plate not closed. Firepot is dirty. Excessive amount of fuel at start-up.	Check that firepot clean-out is fully closed. Clean firepot. Make sure there is not a clinker in the firepot. Clinkers may have to be pushed out of firepot with firepot scraper tool or other means. Reduce feed rate using feed rate adjustment control rod located inside hopper.

Symptom	Possible Cause	Corrective Action
Slow or smoky start-up (Cont'd)	Dirty exhaust and/or venting system.	Check for ash build up in unit, including behind rear panels, firebox, heat exchanger, exhaust blower and venting.
Feed system fails to start.	Out of fuel. #2 snap disc may be defective. Vacuum switch not closing. No vacuum. Feed system jammed or blocked. Feed spring not turning with feed motor. Feed motor defective or not plugged in.	Check hopper, fill with fuel. Replace snap disc. Firebox door must be closed securely. Check exhaust blower is plugged in and operating. Check vacuum switch is plugged in. Check vacuum hose is in good condition, clear and connected at both ends. Check thermocouple is in good condition and plugged in properly. Make sure venting system is clean. NOTE: High winds blowing into the venting system can pressurize the firebox causing loss of vacuum. Empty hopper of fuel. Use a wet/dry vacuum cleaner to remove remaining fuel, from hopper, including feed tube. Check feed chute for obstructions. Loosen 2 feed assembly mounting screws and lightly shake feed assembly. Check that set screw is tight on feed spring shaft at end of feed motor. Check connections on feed motor, replace if defective.
No call light. Unit does not begin start sequence.	Thermostat not set to a high enough temperature. Snap Disc #3 tripped. No power. Fuse blown. Connections at thermostat and/or appliance not making proper contact. Defective thermostat or thermostat wiring. Control box defective.	Adjust thermostat above room temperature. Reset snap disc. Connect to power. Replace fuse. Check connections at thermostat and appliance. Replace thermostat or wiring. NOTE: To test thermostat and wiring, use a jumper wire at the thermostat block on the unit to by-pass thermostat and wiring. Replace control box.
Unit fails to shut off.	Call light on.	Turn thermostat off. If call light does not go out, disconnect thermostat wires from unit. If call light does go out, thermostat or wires are defective.

Symptoms	Possible Cause	Corrective Action
Convection blower fails to start.	#1 snap disc defective. Blower not plugged in. Blower is defective. Control box is defective.	Replace snap disc. Check that blower is plugged into wire harness. Replace blower. Replace control box.
Exhaust blower fails to start or does not shut off.	Blower not plugged in. Blower is clogged with ash. Blower is defective. Control box is defective.	Check that blower is plugged into wire harness. Clean exhaust system. Replace blower. Replace control box.
Large, lazy flame, orange color. Black ash on glass.	Dirty appliance. Poor fuel quality, high ash content. Firepot clean-out plate not completely closed. Excessive amount of fuel.	Clean unit, including firepot, heat exchangers and venting system. Remove stainless steel baffle from firebox to clean ash from on top of baffle. Clean behind rear brick panels. Change fuel brand to premium. Check that firepot clean-out plate is fully closed. Reduce feed rate using feed rate adjustment control rod located inside hopper.
Nuisance shutdowns.	Low flame. Sawdust buildup in hopper. Feed motor is reversing. Defective thermocouple. Defective control box. Firepot more than 1/2 full.	Increase feed by opening feed rate adjustment control rod located inside hopper. Clean hopper, see page 29 . Check for good connections between feed motor and wire harness. Replace thermocouple. Replace control box. See page 30 for detailed instructions for "High Ash Fuel Content Management"
Appliance calls for heat. Call light illuminates. Exhaust blower starts. No feed or igniter.	Thermocouple is defective or not properly plugged in. Defective control box.	Check connections on thermocouple or replace if defective. A flashing yellow light on the control box indicates a problem with the thermocouple. Replace control box.

10 Maintaining & Servicing Your Appliance

A. Proper Shutdown Procedure

CAUTION

Shock and Smoke Hazard

- Turn down thermostat, let appliance completely cool and exhaust blower must be off. Now you can unplug appliance before servicing.
- Smoke spillage into room can occur if appliance is not cool before unplugging.
- Risk of shock if appliance not unplugged before servicing appliance.

C. General Maintenance

1. Types of Fuel

Depending on the type of fuel you are burning will dictate how often you have to clean your firepot.

If the fuel you are burning has a high dirt or ash content or you are burning shelled field corn, it may be necessary to clean the firepot more than once a day.

Dirty fuel will cause clinkers to form in the firepot. A clinker is formed when dirt, ash or a non-burnable substance is heated to 2000°F (1093°C) and becomes glass-like. See **“C” page 31** in this section for more details on fuels with high ash content.

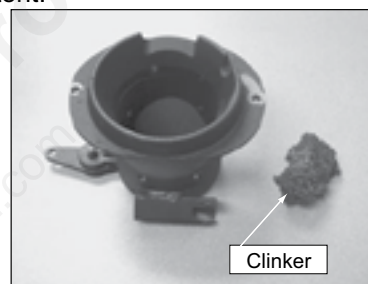



Figure 27.1 - Clinker

B. Quick Reference Maintenance Chart

Cleaning or Inspection	Frequency		Daily	Weekly	Monthly	Yearly
Ash Pan	Every 5 bags of fuel	OR		X		
Ash Removal from Firebox	More frequently depending on the fuel type or ash build-up	OR		X		
Beneath Heat Exchanger	Every 1 ton of fuel	OR			X	
Blower, Combustion (Exhaust)	More frequently depending on the fuel type	OR				X
Blower, Convection	More frequently depending on the fuel type	OR				X
Door Latch Inspection	Prior to heating season	OR			X	
Exhaust Path	More frequently depending on ash build-up	OR				X
Firebox - Prepare for Non-Burn Season	At end of heating season	OR				X
Firepot - Burning pellets	Every 3 bags	OR	X			
Firepot - Burning Corn	Every 1 bag	OR	X			
Glass	When clear view of firepot becomes obscure	OR		X		
Heat Exchanger & Drop Tube	Every 1 ton of fuel	OR			X	
Hopper	Every 1 ton of fuel or when changing fuel types	OR			X	
Top Vent Adapter	More frequently depending on the fuel type or ash build-up	OR				X
Venting System	More frequently depending on the fuel type	OR				X

2. Cleaning Firepot with Cleaning Rod & Firepot Scraper

- **Frequency:** Daily or more often as needed
- **By:** Homeowner
 - a. The appliance must be in complete shutdown and cool and the exhaust blower off. If you are just cleaning the firepot, there is no need to unplug the appliance.
 - b. Pull firepot cleaning rod OUT a couple of times to help shake debris loose. **See Figure 37.2 on page 37.** If rod is hard to pull, it may be necessary to use your firepot clean-out tool to chip away material that has built up on the bottom plate of the firepot and to push out any clinkers. Larger clinkers may have to be removed from the top of the firepot. Corn clinkers can be especially difficult to break up.
 - c. The firepot floor plate must be fully closed when finished. **See Figure 23.1 on page 23.**

	WARNING
	<p>Fire Risk</p> <ul style="list-style-type: none"> • NEVER pull firepot cleaning rod or cleaning slide plates out when appliance is operating. • The cleaning slide plates must be fully CLOSED when appliance is operating. • Hot pellets may fall into ashpan and start a fire or mis-starts due to lack of vacuum.

3. Ash Removal from Firebox

- **Frequency:** Weekly or more frequently depending on ash build-up.
- **By:** Homeowner
 - a. Allow the appliance to completely cool down. There must not be any hot ashes in the firebox during cleaning. Turn the thermostat on and then immediately off to start the exhaust blower on its cycle time. It will pull fly ash out the exhaust instead of into the room.
 - b. Frequent cleaning of the ash in the firebox will help slow down the build-up of ash in the exhaust blower and vent system.
 - c. Open cast hinged face. Remove ash with an ash vacuum or whisk broom and small dust pan.
 - d. This ash is deposited in the same ash pan as the firepot debris. The ash pan should be emptied every time you clean the firebox. Remember to place the ash and debris into a metal or non-combustible container. **See Disposal of Ashes.**

	WARNING
	<p>Disposal of Ashes</p> <ul style="list-style-type: none"> • Ashes should be placed in metal container with tight fitting lid. • Ashes should be retained in closed container until all cinders have thoroughly cooled.

4. Cleaning Ash Pan

- **Frequency:** Weekly or every 5 bags of fuel
- **By:** Homeowner

Locate the ash pan underneath the firepot. Open the bottom ash door and slide the ash pan straight out. Empty into a non-combustible container and re-install ash pan. **See Disposal of Ashes.**

5. Disposal of Ashes



- **Frequency:** As needed
- **By:** Homeowner

Ashes should be placed in a metal container with a tight-fitting lid. The closed container of ashes should be placed on a non-combustible floor or on the ground, well away from all combustible materials, pending final disposal.

If the ashes are disposed of by burial in soil or otherwise locally dispersed, they should be retained in the closed container until all cinders have been thoroughly cooled.

7. Cleaning Heat Exchanger Chambers & Drop Tube

- **Frequency:** Monthly or every 1 ton of fuel
- **By:** Homeowner

	WARNING
	<p>Heat exchanger cleaning rods may be warm to the touch. For safety purposes wear gloves.</p> <p>Do not pull heat exchanger cleaning rods while appliance is operating.</p> <p>Push cleaning rods IN when done, DO NOT leave cleaning rods OUT. Injury can occur.</p>

The amount of ash buildup in the firepot will be a good guide to determine how often you should clean the heat exchangers.

- a. Allow the appliance to completely cool down before pulling the cleaning rods. Turn the thermostat on and then immediately off to start the exhaust blower on its cycle time. It will pull fly ash out the exhaust instead of into the room. Open the cast hinged face to access the 2 cleaning rods. **See Figure 29.1 on page 29.**
- b. Locate the 2 rods directly underneath the heat exchanger tubes. Rods are bent at a 90° angle for easy handling.
- c. To clean, pull the rods straight out until it stops, approximately 5-1/2 inches (140mm). Slide the rods OUT and IN a couple of times.

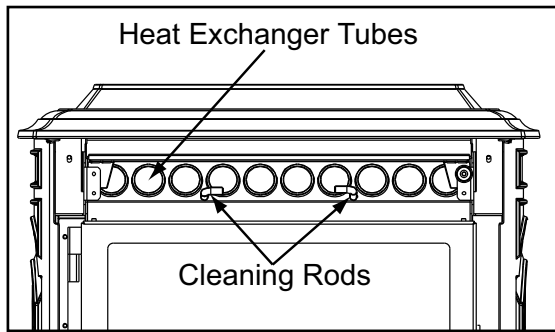

Figure 29.1

8. Cleaning Beneath Heat Exchanger

- **Frequency:** Monthly or after burning 1 ton of fuel
- **By:** Homeowner
 - a. Be sure the appliance is allowed to cool, has been unplugged and the exhaust blower is off
 - b. A more thorough cleaning is needed to remove the excess ash that is left behind from the use of the cleaning rods for the heat exchanger tubes.
 - c. The ash will be resting on the back of the baffle. This will require removing the cast baffle. Please refer to **page 33** for a detailed explanation of removing the baffle.

NOTE: There are heavy duty vacuum cleaners specifically designed for solid fuel appliance cleaning.

9. Cleaning the Exhaust Path

- **Frequency:** Yearly or more frequently depending on ash build-up.
- **By:** Homeowner
 - a. Appliance must be completely cool.
 - b. Open cast hinge face. Remove right brick and thoroughly vacuum the area and continue throughout the rest of the firebox.
 - c. Replace right brick and close cast hinge face.

10. Cleaning the Hopper

- **Frequency:** Monthly or after burning 1 ton of fuel
- **By:** Homeowner

After burning approximately 1 ton of fuel you will need to clean the hopper to prevent sawdust build-up.

A combination of sawdust and pellets on the auger reduces the amount of fuel supply to the firepot. This can result in nuisance shutdowns and mis-starts.

- a. The appliance must be in complete shutdown. Allow the appliance to completely cool down.
- b. Empty the hopper of any remaining pellets.
- c. Vacuum the hopper and feed tube.

11. Soot and Fly Ash: Formation & Need for Removal in Exhaust Venting System.

- **Frequency:** Yearly or more frequently depending on ash build-up.
- **By:** Qualified Service Technician/Homeowner

Be sure the appliance is allowed to cool, has been unplugged and the exhaust blower is off.

The products of combustion will contain small particles of fly ash. The fly ash will collect in the exhaust venting system and restrict the flow of the flue gases.



At start-up if there is incomplete combustion, or if there is a shutdown or incorrect operation of the appliance it will lead to some soot formation. This will collect in the exhaust venting system.

The venting system may need to be cleaned at least once a year or more often depending upon the quality of your fuel or if there is a lot of horizontal pipe sections. Ash will build up more quickly in the horizontal sections.

12. Cleaning the Glass

- **Frequency:** When clear view of the firepot becomes obscure
- **By:** Homeowner
 - a. Appliance must be completely cool before cleaning glass.
 - b. Use a damp paper towel or any non-abrasive glass cleaner. Wipe off with dry towel.

CAUTION	
	<p>Handle glass assembly with care.</p> <p>When cleaning glass:</p> <ul style="list-style-type: none"> • Avoid striking, scratching or slamming glass. • Do NOT clean glass when hot.
<ul style="list-style-type: none"> • Do NOT use abrasive cleaners. • Use a hard water deposit glass cleaner on white film. • Refer to maintenance instructions. 	

 WARNING	
	<p>Handle glass with care.</p> <ul style="list-style-type: none"> • Inspect the gasket to ensure it is undamaged. • Do NOT strike, slam or scratch glass. • Do NOT operate appliance with glass assembly removed.
<ul style="list-style-type: none"> • Do NOT operate with glass cracked, broken or scratched. 	

13. Cleaning Convection Blower - Requires No Lubrication

- **Frequency:** Yearly or as needed
- **By:** Qualified Service Technician / Homeowner

The convection blower is located at the bottom rear of the stove. It is housed inside the screen box. See **page 31** for detailed instructions on removing the blower.

The blower has two impellers, one on each side of the motor. They should be cleaned at least once each year or more often as needed.

14. Cleaning Exhaust Blower - Requires No Lubrication

- **Frequency:** Yearly or as needed
- **By:** Qualified Service Technician
- **Task:** Contact your local dealer.

15. Door Latch Inspection

- **Frequency:** Prior to heating season
- **By:** Homeowner

The door latch is non-adjustable but the gasketing between the glass and firebox should be inspected periodically to make sure there is a good seal.

16. Cleaning the Top Vent Adapter

- The appliance must be in complete shutdown and the exhaust blower should be off. Allow the appliance to completely cool down.
- Open the clean out cover. **See Figure 30.1.**
- Sweep out any ash build-up.

NOTE: *There are heavy duty vacuum cleaners specifically*

17. Preparing Firebox for Non-Burn Season

- **Frequency:** Yearly
- **By:** Homeowner
 - Be sure the appliance is allowed to cool, has been unplugged and the exhaust blower is off.
 - Remove all ash from the firebox and vacuum thoroughly.
 - Paint all exposed steel, including cast-iron.
 - Use the Touch-Up paint supplied with the appliance; or;
 - Purchase paint from your local dealer.
 - Must use a high-temperature paint made specifically for heating appliances.

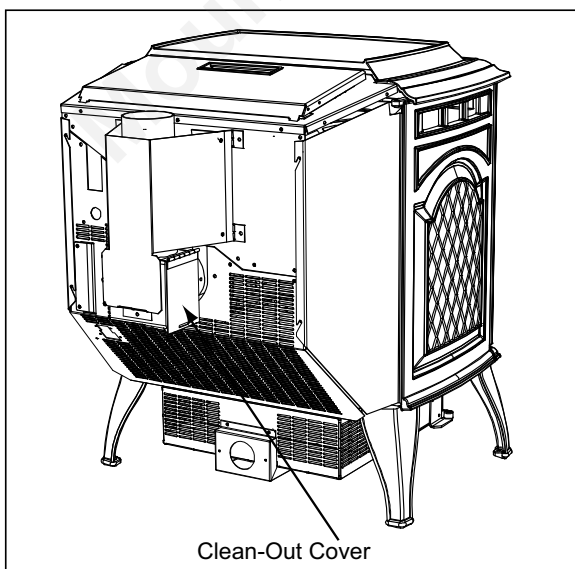

Figure 29.1

C. High Ash Fuel Content Maintenance

- **Frequency:** When the ash build-up exceeds more than half way up the firepot.
- **By:** Homeowner

Poor quality pellet fuel, or lack of maintenance, can create conditions that make the firepot fill quickly with ashes and clinkers.

This condition makes the appliance susceptible to overfilling the firepot with pellets which may result in smoking, sooting and possible hopper fires. **Figure 31.1** shows an example where the firepot overfills, pellets back up into the feed tube and ash has accumulated in the firebox.

An inefficient and non-economical method of burning of fuel caused by poor quality pellet fuel is shown in **Figure 31.2**.

The correct flame size when good quality, premium pellet fuel is burned is shown in **Figure 31.3**.

If the ash buildup exceeds the half way point in the firepot **IMMEDIATE ATTENTION AND CLEANING IS REQUIRED.**



Figure 31.1



Figure 31.2

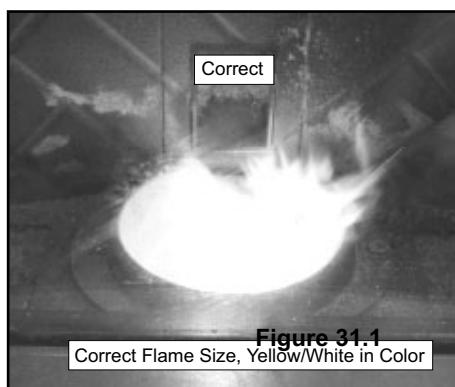

Figure 31.3

D. Blower Replacement

1. Convection Blower Replacement

- Turn down thermostat, let appliance completely cool and then unplug appliance before servicing.
- The convection blower is located at the bottom rear of the appliance and is housed inside a screen box. Remove the 2 screws facing forward in the center of the blower chamber at the very back of the appliance.
- If an outside air kit is installed on the appliance, these screws attach the intake air channel piece of the outside air kit to the appliance. Remove the 2 screws and pull backwards on the channel and it will slide down and away from the appliance. The air channel, collar and outside air hose will be removed as one piece.
- There are 2 screws on each side of the housing. Loosen all 4 screws, but do not remove them. Lift the blower housing up slightly and slide towards you. **Figure 31.4**.
- Remove the left side panel by loosening 2 screws (do not remove) and pull side panel away. Unplug the 2 black blower wires by disconnecting the spade connectors.
- To remove blower from the housing, remove 2 screws in the front of the housing and very carefully bend the 2 housing sides out and bend the back of the housing away from the blower. This allows for room to access the back 2 screws and nuts (4 total) that is securing the blower to the housing.
- Remove blower and replace with new blower.
- Re-install in reverse order.

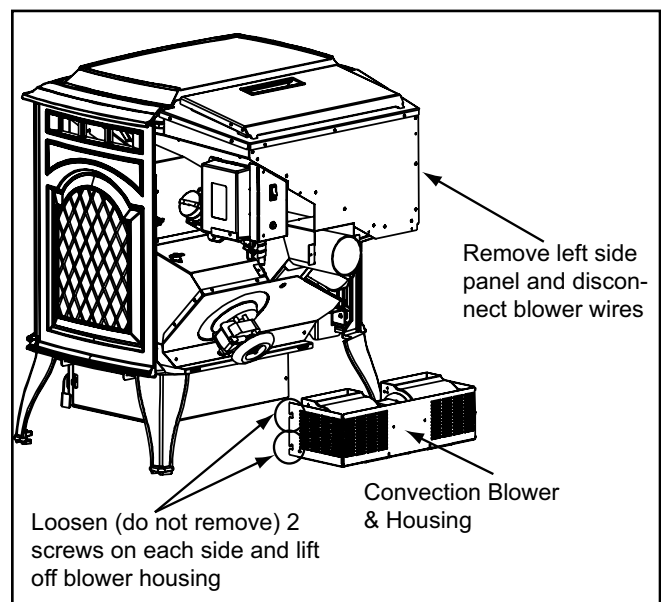

Figure 31.4

2. Combustion Blower Replacement

NOTE: The convection blower must be removed before the exhaust blower can be removed.

- a. Turn down thermostat, let appliance completely cool and then unplug appliance before servicing.
- b. Remove both side curtains by loosening 2 screws (do not remove) and pull side panels away.
- c. Remove 7 screws from the back screen and pivot the top of the screen toward you leaving the bottom attached to stove. **Figure 32.1.**
- d. Remove 2 screws to remove the thermostat block and disconnect the 2 yellow wires.
- e. Remove the 2 screws from the power inlet and rotate it through the hole and out of the screen, leaving the wires attached.
- f. Disconnect the vacuum hose and both wires (orange and red) from the vacuum switch attached to the rear screen.
- g. Remove both wires from exhaust blower (blue and double white).
- h. Remove 6 screws using a flathead screwdriver or a 1/4" nutdriver. Retain screws for use on replacement blower. **Figure 32.2.**
- i. Remove exhaust blower and gasket.
- j. Install new gasket and blower. Discard blower housing if not needed.
- k. Re-install in reverse order.

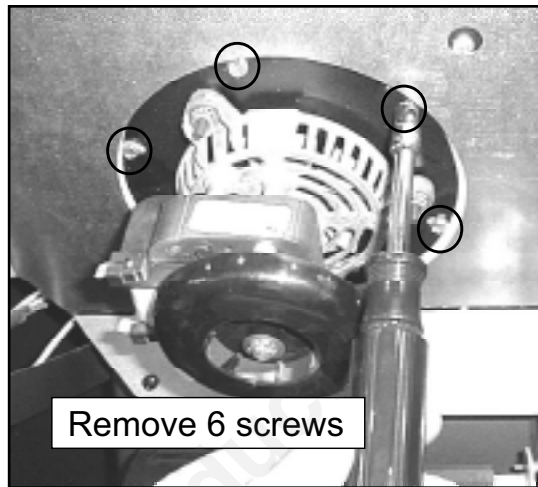

Figure 31.2

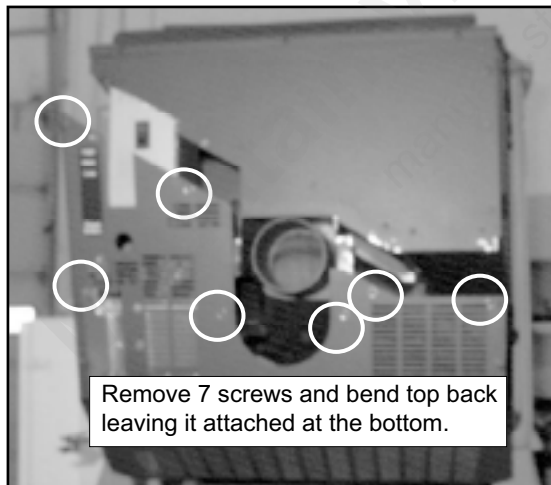

Figure 32.1

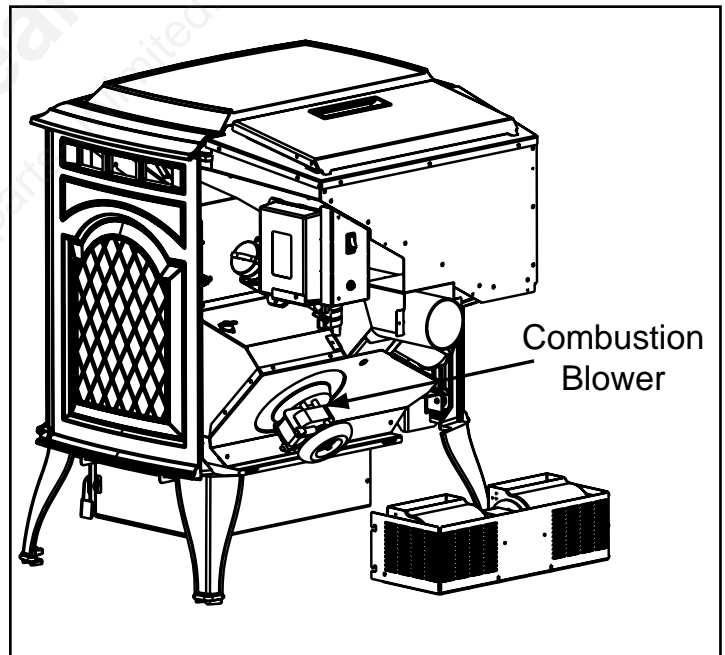

Figure 32.3

E. Igniter Replacement

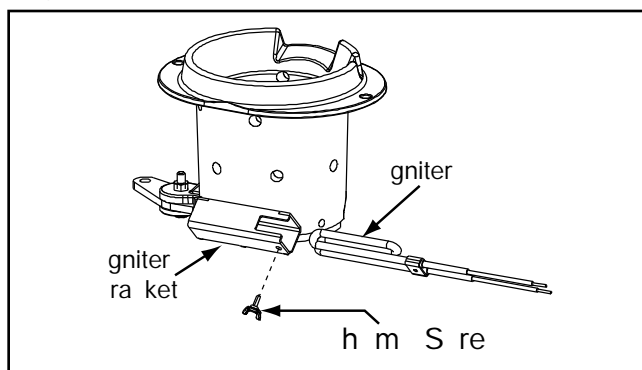

Figure 33.1

- Turn down thermostat, let the appliance completely cool and then unplug appliance before servicing.
- Open the ash door and remove the ash pan. Remove the left side panel by loosening 2 screws (do not remove) and pull side panel away.
- The wire leads to the igniter are connected to the wire harness (black wires) with 1/4 inch male / female spade connectors. Disconnect the spade connections. Loosen the thumb screw and slide igniter out.
- Install new igniter into the chamber and tighten the thumb screw.
- Re-connect the wires to the 2 leads with the spade connectors. Double check that the igniter wires are clear of any movement, i.e. ash pan, firepot cleaning rod, cleaning slide plates, etc.
- Re-install the ash pan, close the ash removal door.

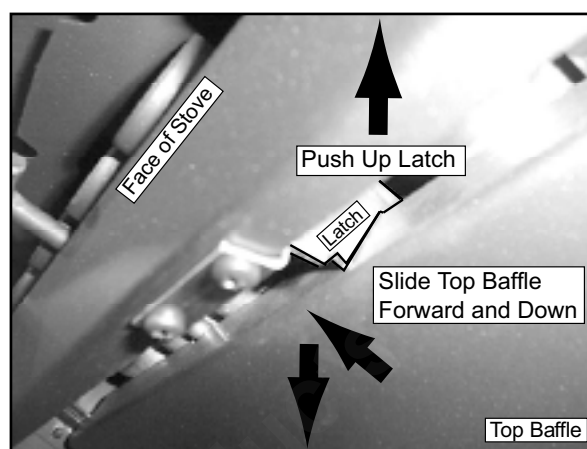

Figure 33.2

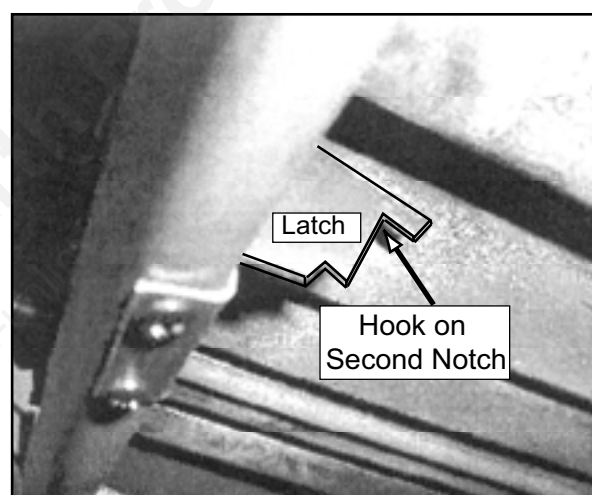

Figure 33.3

F. Baffle Removal

NOTE: There is a latch on the appliance to keep the top baffle from coming out during shipment or when the heat exchanger scraper rods are pulled.

- Allow appliance to cool completely.
- Open doors and locate the latch. It is located between the front edge of the top baffle and the inside of the firebox centered from side to side. The latch pivots up and down.
- Push the latch up with your finger while sliding the top baffle forward and down. **Figure 33.2.**
- To re-install the top baffle, align the hooks on the baffle with the slots in the baffle hangers, push up and slide back. **Figure 33.3.**
- Make sure the latch drops back into position, bypassing the first notch and catching the front edge of the top baffle with the second small notch.

G. Glass Replacement

 WARNING	
	<ul style="list-style-type: none"> • Glass is 5mm thick high temperature heat-resistant ceramic glass. • DO NOT REPLACE with any other material. • Alternate material may shatter and cause injury

- a. Open the face and remove door from the appliance by lifting door off of hinge pin and lay on a flat surface face down.
- b. Using a screwdriver, tap the bottom of the rope retainer rod to push it up out of the hole. The top end of the rod will slide up. Swing the rod toward you from the bottom and remove the rod. Repeat for other side.
- c. Remove old glass and replace with new glass.
- d. Slide the retainer rod into the top hole first, and then line up the bottom crimped end with the hole in the door. The crimped end must be parallel with the glass in order to insert it into place. **Figure 34.1.**

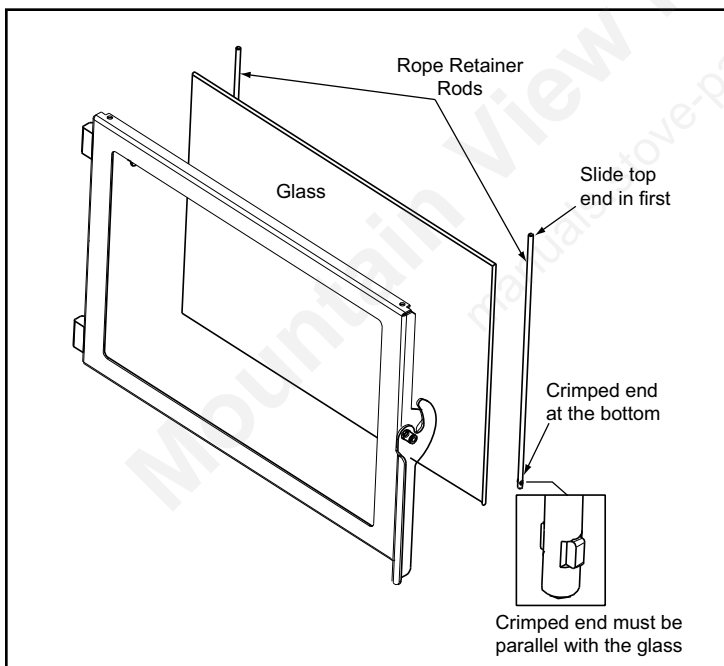

Figure 34.1

11

Reference Materials

A. Component Function



When describing the location of a component, it is always **AS YOU FACE THE FRONT OF THE APPLIANCE**.

1. Control Box

- a. The control box is located on upper right side of appliance, behind the right side panel and above the vacuum switch.
- b. There is a light located inside of the control box. The internal light will turn green when the appliance has reached a temperature of 175°F (79°C) in the firepot. and will turn red when it reaches 600°F (315°C).
- c. There is also an internal blue light located in the upper left corner of the control box. When you plug in the appliance the blue light will automatically start blinking 4 times in a row for 60 seconds and then will stop.

NOTE:

Do **NOT** open the control box. This will void the warranty. Follow proper shutdown procedures first if you need to plug in or remove the control box.

2. Convection Blower

The convection blower is mounted at the bottom rear of the appliance. There are 2 impellers, one on each side of the motor. The convection blower pushes heated air through the heat exchange system into the room.

3. Combustion Blower

The combustion blower is located on the right side of appliance and is designed to pull the exhaust from the appliance and push it out through the venting system.

4. Feed System

The feed system is located on the right side of the appliance and can be removed as an entire assembly. The assembly includes the feed motor, mounting bracket, bearing and feed spring (auger). The hollow feed spring (auger) pulls pellets up the feed tube from the hopper area and drops them down the feed chute into the firepot.

5. Firepot

The firepot is made of high quality ductile iron and has a cleaning pull-out rod. The floor of the firepot opens for cleaning when you pull out the rod. Be sure that the floor returns to a completely closed position or your appliance will not operate properly.

6. Fuse

The fuse is located on the front of the junction box on the right side of appliance. The fuse will blow should a short occur and shut off power to the appliance.

7. Heat Exchangers

The heat exchangers transfer hot air from the exhaust system into convection air. Remove the stainless steel top baffle to access the heat exchangers. There are 2 clean out rods located under the heat exchangers.

8. Heat Output Switch

The heat output switch is located on the upper right rear corner. The function of the heat output switch is to regulate the burn rates; low, medium and high settings.

9. Igniter

The igniter is mounted on the base of the firepot. Combustion air travels over the red hot igniter creating super heated air that ignites the pellets.

10. Junction Box And Wiring Harness

The junction box is located on the right side of the appliance, behind the right side panel. The junction box and wiring harness are replaced as one component.

11. Power Supply

The power outlet is located on the lower right rear corner. Check the wall receptacle for 120 volt, 60 Hz (standard current). Make sure the outlet is grounded and has the correct polarity. A good surge protector is recommended.

12. Red Call Light

The red call light is on the front of the junction box, behind the control box. The function of the red call light is to indicate that the thermostat is calling for heat.

13. Reset Button

The reset button is located on the back of the appliance on the upper right corner of the side panel under the heat output control switch. The function of the button is to momentarily open the thermostat circuit, which restarts the system.

14. Thermocouple

The thermocouple is located on top of the firepot inside the thermocouple cover (ceramic protection tube). The thermocouple sends a millivolt signal to the control box indicating the preset temperatures of the green and red lights have been obtained.

15. Thermostat

The appliance is designed to run on a 12 volt AC thermostat. The heat anticipator should be set on the lowest setting available.

16. Snap Disc #1 (Convection Blower) 110°F

Snap disc #1 is located on the right side of the appliance on the top of the heat exchanger box. There are 2 purple wires connected to it. This snap disc turns the convection blower on and off as needed. Power is always present at snap disc #1.

17. Snap Disc #2 (Fuel Delivery Interrupt) 250°F

Snap disc #2 is also located on the back side of the feed drop tube. There are 2 orange wires connected to it. This snap disc will turn off the feed system which will turn off the appliance if an overfire condition should occur or if the convection blower should fail to operate. If this occurs the snap disc will automatically reset itself.

18. Snap Disc #3 (Back Burn Protector) 250°F

Snap disc #3 is mounted on the back of the auger tube in the center of the appliance and has a red reset button. To access it remove the right side panel. If the fire tries to burn back into the feed system or push exhaust up the feed tube,

this snap disc will shut the entire system off. This disc must be manually reset.

19. Vacuum Switch

The vacuum switch is located on the right side of the appliance behind right side panel. This switch turns the feed system on when vacuum is present in the firebox. The vacuum switch is a safety device to shut off the feed motor if the exhaust or the heat exchanger system is dirty or plugged or if the firebox door is open.

20. Wiring Harness

See Figure 36.1 below.

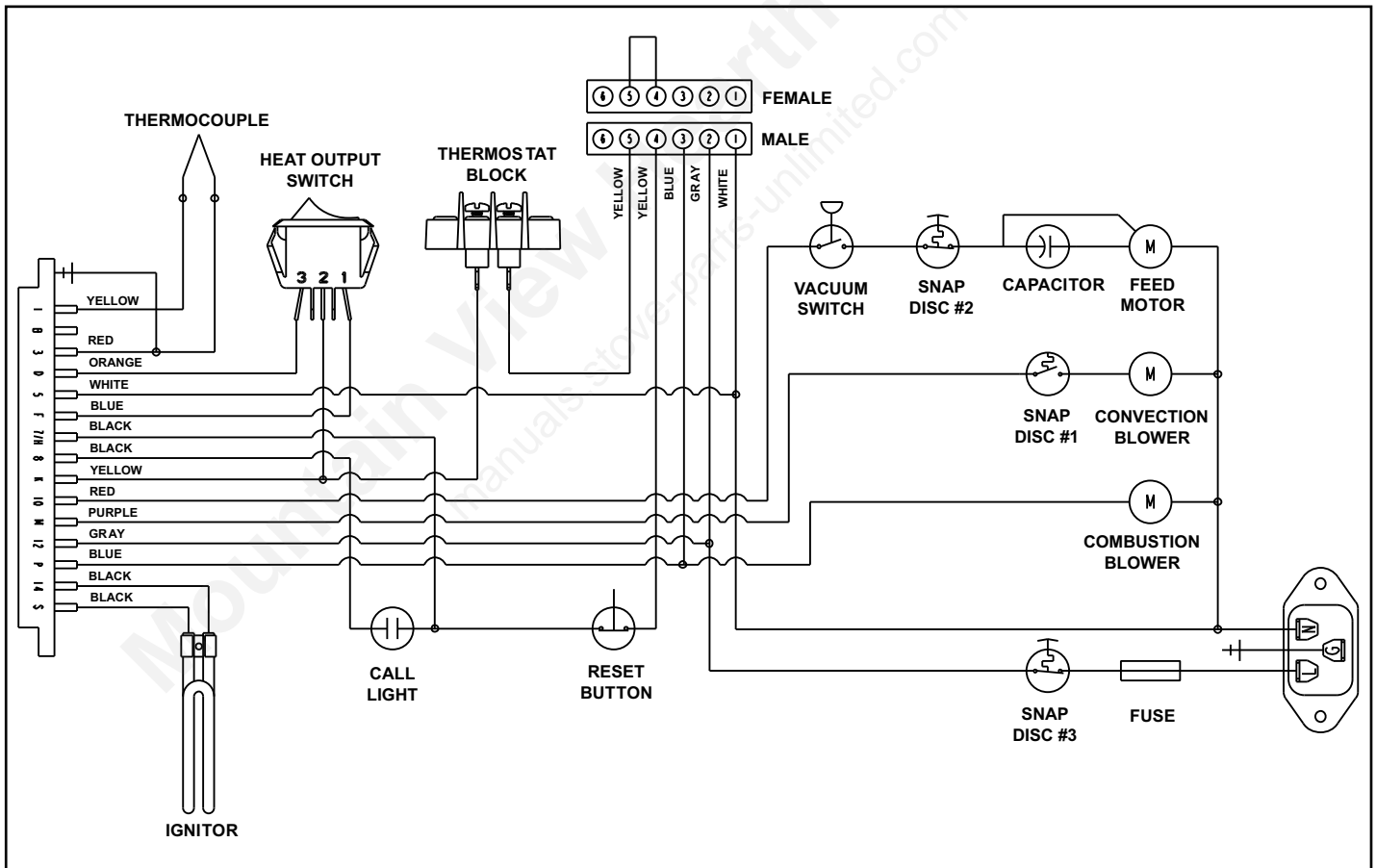

Figure 36.1

B. Component Locations

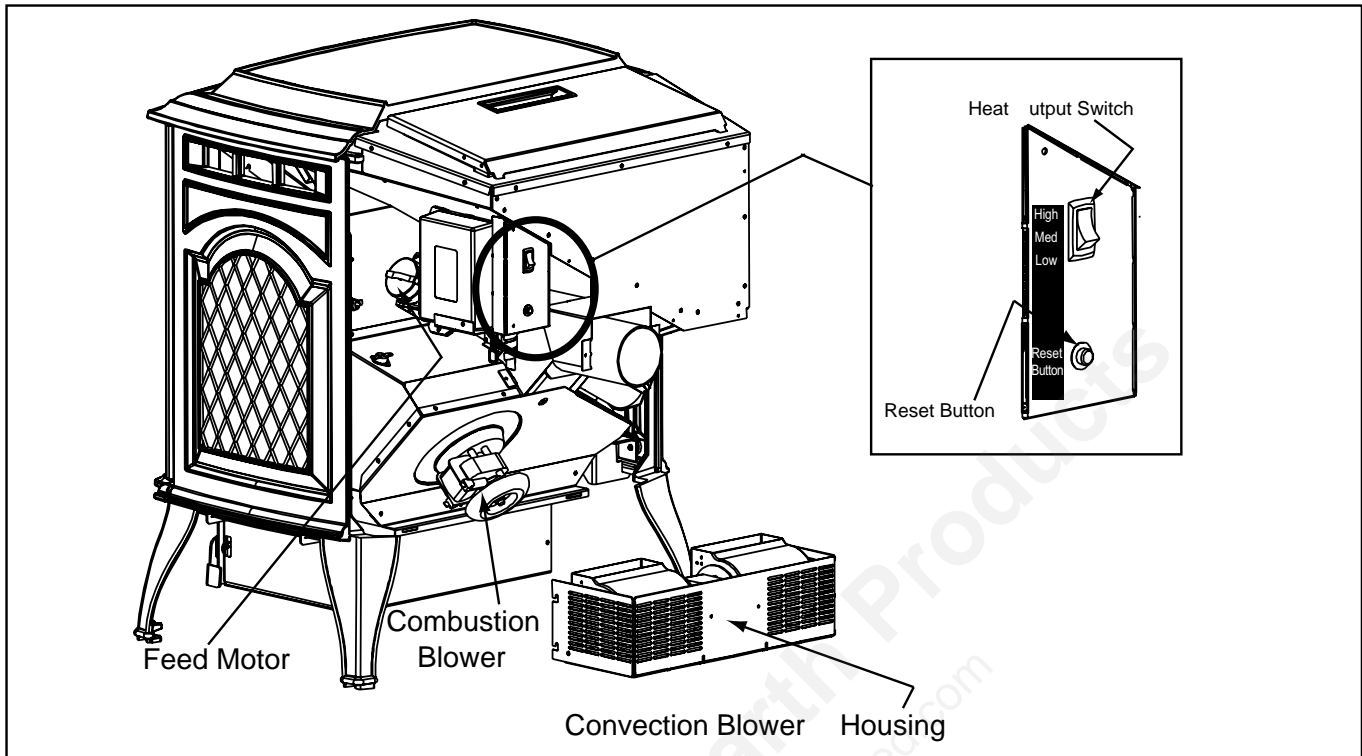

Figure 37.1

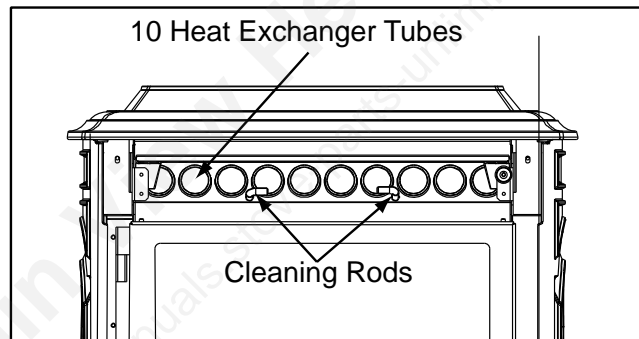

Figure 37.2

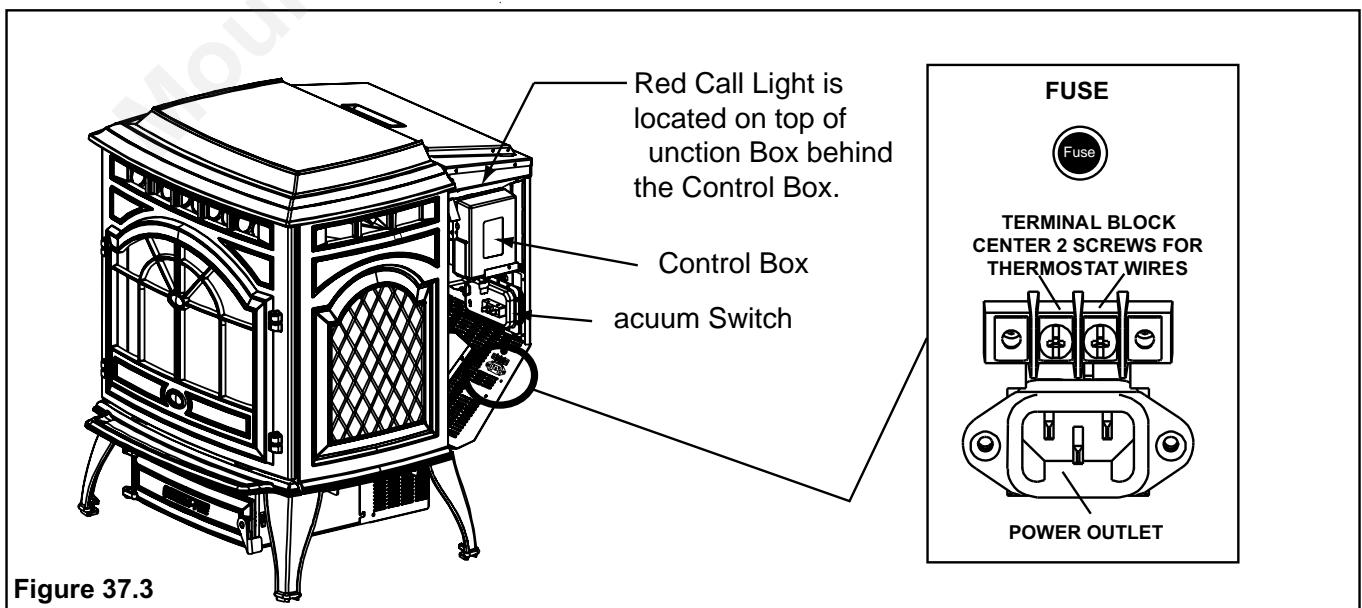
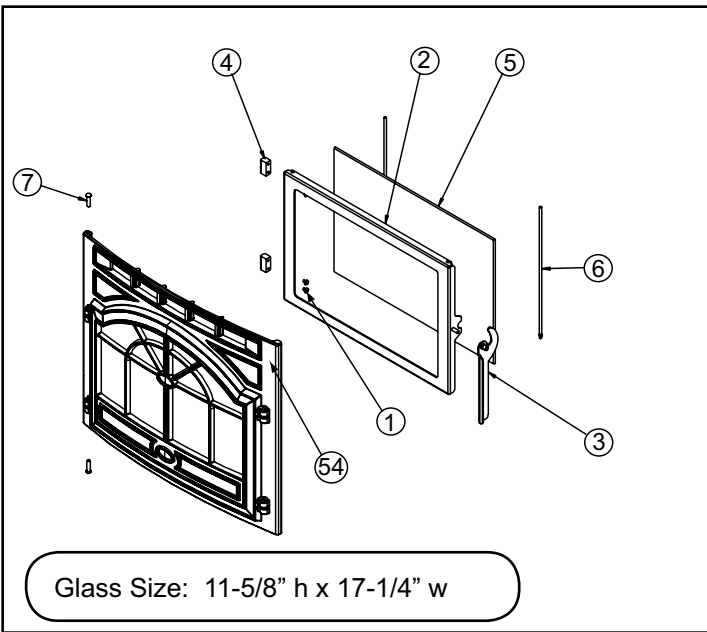

Figure 37.3

C. Exploded Views



Item	Description	Part Number
1	Screw, 10-32 x 1/4 PH PHL MS ZC	229-1230
2	Door Frame	not sellable
3	Door Latch Assembly	413-5200
4	Hinge, Door (Female)	450-2910
5	Glass Assembly	7001-038
6	Rope Retainer	7001-192
7	Hinge Pin (Rivet)	25272
54	Face, Cast	See Parts List

Figure 38.1 - Door, Face, Glass & Door Latch Assembly

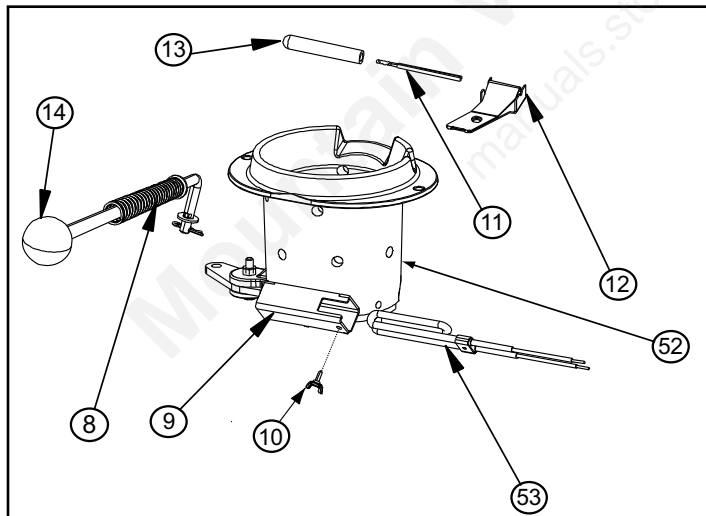

Item	Description	Part Number
9	Igniter Bracket	not sellable
10	Thumb Screw	7000-223/24
11	Thermocouple	812-4470
12	Thermocouple Clamp	7001-203
13	Thermocouple Cover	812-1322
14	Knob	200-0831
52	Firepot	SRV414-5200
53	Igniter	SRV7000-462
67	Firepot Pull Rod	not sellable

Figure 38.2 - Firepot Assembly

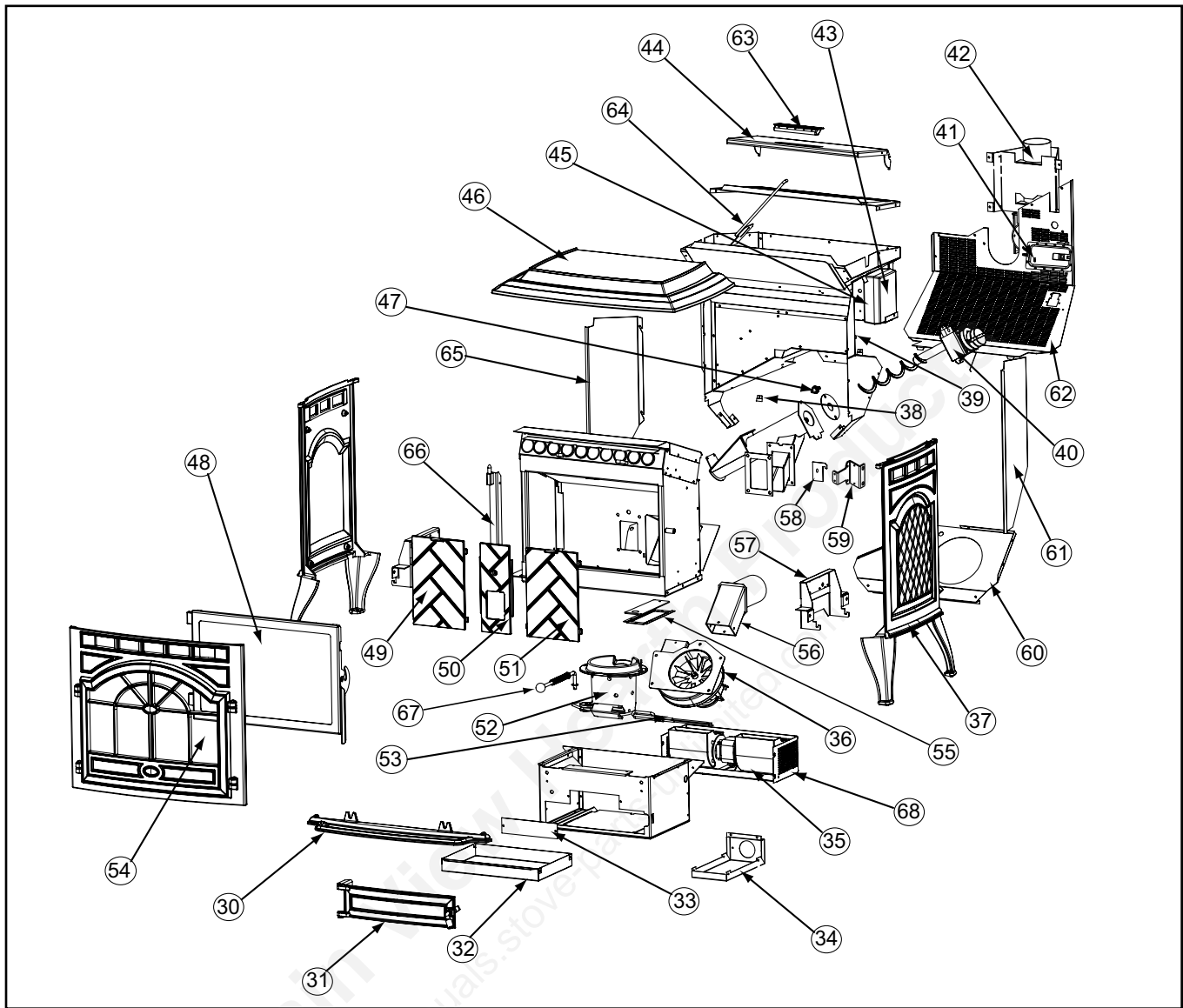

Figure 39.1

Item No.	Part Description	Item No.	Part Description	Item No.	Part Description
30	Ash Catcher	43	Control Box	56	Exhaust Transition Assy
31	Ash Door Assembly	44	Hopper Lid Assembly	57	Side Mount, Bottom
32	Ash Pan	45	Junction Box & Wire Harness	58	Side Top Hook, Cast
33	Igniter Access Plate	46	Top Cast	59	Side Top Mount, Cast
34	Channel, Air Intake Outside Air Kit (included in OAK Accsry Kit)	47	Snap Disc #3	60	Exhaust Shroud Back
35	Blower, Convection	48	Door & Glass Assembly	61	Outer Skin, Side, Right
36	Blower, Exhaust	49	Brick, Left	62	Outer Skin, Back
37	Side, Cast (interchangeable)	50	Brick, Center	63	Handle, Hopper Lid
38	Snap Disc #2	51	Brick, Right	64	Feed Adjustment Plate
39	Snap Disc #1	52	Firepot Assembly	65	Outer Skin, Side, Left
40	Feed Motor Assembly	53	Igniter, Loop	66	Hinge Bracket
41	Vacuum Switch	54	Face, Cast	67	Firepot, Cleaning Pull Rod Assy
42	Top Vent Kit (Accsry Item)	55	Ash Clean-Out Plate	68	Shroud, Convection Blwr

D. Service Parts and Accessories

IMPORTANT: THIS IS DATED INFORMATION. The most current information is located on the Quadra-Fire web site at www.quadrafire.com. When ordering, supply serial and model numbers to ensure correct service parts.

Item No.	Service Parts	Part No.
55	Ash Clean-Out Plate	7001-186
31	Ash Door Assembly	812-4600
32	Ash Pan	413-0400
30	Ashcatcher, Cast, Matte Black	413-0010MBK
30	Ashcatcher, Cast, Porcelain (specify color)	413-0010POR
30	Ashcatcher, Cast, Powder Coat (specify color)	413-0010PWD
	Baffle, Top, Stainless Steel	413-0360
	Bearing, Feed System, Nylon	410-0552
35	Blower, Convection, Motor Only, with Spade Connectors	812-4900
36	Blower, Combustion (Exhaust) with gasket & housing	812-4400
66	Bracket, Hinge	SRV413-0550
	Bracket, Magnet	413-0520
	Bracket, Snap Disc	7005-253
50	Brick, Center	412-0960
49	Brick, Left	412-0950
51	Brick, Right	412-0970
	Bumper, Rubber for Hopper Lid, Pkg of 12	SRV224-0340/12
	Call Light, Fluorescent	SRV7000-122
	Channel, Air Intake, Outside Air Kit	413-7040
	Component Pack (Includes firepot clean-out tool, touch-up paint, power cord & wiring harness to thermostat and manual, 2 leveling nuts & screws, owner's manual, warranty card, "How-to-Operate" DVD)	413-5130MBK 413-5150PCR 413-5180PMH 413-5140CLG 413-5230CSB 413-5240CWL
43	Control Box	SRV7000-205
	Cover, Outside Air, Floor Installation	411-1071
	Deflector, Air Wash (Bottom)	413-0680
48	Door Assembly & Glass Assembly with bottom air wash	413-5110
	Door Latch Assembly with Hex Rivnut	413-5200
56	Exhaust Transition Assembly	SRV413-5020
54	Face, Matte Black	413-0030MBK
54	Face, Porcelain (specify color)	413-0030POR
54	Face, Powder Coat (specify color)	413-0030PWD
	Feed Adjustment Plate, 1 piece	7001-182
	Feed Motor Bracket with PEM Studs	7001-039
40	Feed Motor Only with capacitor	812-4421
	Feed Motor & Spring Assembly	812-4760
	Feed Spring Assembly with Nylon Gasket	SRV7001-046
	Firepot Clean-Out Tool	414-1140
	Firepot Bottom Slide Plate	414-0290

Item No	Service parts	Part No.
	Firepot Bolt, 1-1/4 inch long	225-0120
	Firepot Nut, 1/4-20	226-0090
52	Firepot, EZ Clean	SRV414-5200
	Firepot, Cleaning Pull Rod Assy	413-5100
	Fuse, 7 amp, Junction Box	812-0380
	Fuse .8 amp, Control Box	812-3780
	Gasket (Rope) 1/4 inch, 10 ft.	834-1460
	Gasket (Rope), Door, 3/4 inch, 7 ft	832-1680
	Gasket, Combustion Blower	240-0812
	Gasket, Combustion (Exhaust Blower) Round White	812-4710
	Gasket (Rope) 1/4 inch, 10 ft. for Ash Drawer	834-1460
	Gasket, Feed Motor	240-0731
	Gasket, Firepot	240-0930
	Gasket, Tadpole, 10 ft for Door/Glass Assembly	842-5130
	Glass Assembly with gasket	7001-038
	Handle, Ash Removal System	472-5060
	Handle Hopper Lid	200-0110
	Heat Output Control Switch, 3 positions, (Rocker Switch)	812-3500
	Hinge, Door (Female)	450-2910
	Hinge Pin, (Rivet)	25272
	Hitch Pin Clip	229-0360
44	Hopper Lid Assembly	413-5210
	Igniter, Loop, with thumb screw (Heating Element)	SRV7000-462
45	Junction Box & Wiring Harness	SRV7001-194
	Knob, Firepot Pull Rod	200-0831
	Leveling Assembly	7000-000
	Log, Front, Left	7001-231
	Log, Front, Right	7001-230
	Log, Rear, Left	7001-233
	Log, Rear, Right	7001-232
	Magnet, Round	SRV7000-140
62	Outer Skin, Back	413-0440
65	Outer Skin, Side, Left	413-0450
61	Outer Skin, Side, Right	413-0460
	Outside Air Cap Assembly	7001-044
	Outside Air Collar Assembly	7001-045
	Patin, Touch-up, Matte Black	7000-304
	Power Cord	812-1180
	Rope Retainer for Door Gasket	7001-192
	Shroud, Convection Blower	SRV413-0300
	Shroud, Exhaust Back	SRV413-0310
37	Side, Cast, Matte Black (left & right interchangeable)	413-0040MBK
37	Side, Cast, Porcelain (specify color, left & right interchangeable)	413-0040POR

37	Side, Cast, Powder Coat (specify color, left & right interchangeable)	413-0040PWD
58	Side Top Hook, Cast	413-0730
59	Side Top Mount, Cast	413-0720
57	Side Mount, Bottom	413-0230
39	Snap Disc #1, 110 degree, Convection Fan	230-1220
39	Snap Disc #2, 250 degree, Auto Reset, L250-095F	SRV7000-268
47	Snap Disc #3, 250 degree, Manual Reset	230-1290
	Snap Disc, Wire Harness	7001-224
	Thermocouple Clamp	7001-203
	Thermocouple Cover (ceramic protection tube)	812-1322
	Thermocouple Cover, 10 pack	812-4920
	Thermocouple, 14 inch	812-4470
	Thermostat Block Terminal DV	230-0690
	Thermostat Wire Harness	230-0810
46	Top, Cast, Matte Black	413-0050MBK
46	Top, Cast, Porcelain (specify color)	413-0050POR
46	Top, Cast, Powder Coat (specify color)	413-0050PWD
41	Vacuum Switch, Rectangular	SRV7000-447

Item No.	Accessories	Part No.
	Log Set, 4 pieces	811-0852
	Log, Top (to cover firepot)	811-0900
	Outside Air Kit	811-0872
	Rear Vent Adapter, 3 to 3 inches	811-0620
	Rear to Top Vent Adapter, 3 to 3 inches	811-0610
42	Top Vent Adapter Kit, 3 to 3 inches	TPVNT-2
	Top Vent Adapter Offset Collar, 3 to 6 inches	812-3570
	Thermostat, Mechanical (included with appliance)	812-3760
	Thermostat, Programmable	811-0520
	Remote Control Smart Stat II	841-0960
	Remote Control Smart Bat II	841-0970

Item No.	Appliances	Part No.
	Castile Pellet Stove, Matte Black	CASTILE-MBK1
	Castile Pellet Stove, Porcelain Mahogany	CASTILE-PMH1
	Castile Pellet Stove, Powder Coat, Sienna Bronze	CASTILE-CSB
	Castile Pellet Stove, Powder Coat, Willow	CASTILE-CWL

E. Homeowner's Notes

Mountain View Hearth Products
manuals.stove-parts-unlimited.com

F. Warranty Policy

Hearth & Home Technologies LIMITED WARRANTY

Hearth & Home Technologies (“HHT”) and its respective brands extends the following warranty for HHT gas, wood, pellet and electric appliances purchased from an authorized HHT dealer and installed in the United States of America or Canada. Warranty starts with date of purchase by the original owner (End User) except as noted for replacement parts.

Warranty Period		HHT Manufactured Appliances and Venting						Components Covered
Parts	Labor	Gas	Wood	Pellet	EPA Wood	Electric	Venting	
1 Year		X	X	X	X	X	X	All Parts and Material Except as covered by Conditions, Exclusion, and Limitations listed
2 years				X	X			Igniters, Electronic Components, and Glass
		X	X	X	X			Blowers
			X					Molded Refractory Panels
3 years				X				Firepots
5 years	3 years			X	X			Castings & Baffles
7 years	3 years		X	X	X			Firebox, HHT Chimney, Termination & Heat Exchanger
10 years	1 year	X						Burners, Logs & Refractory
Limited Lifetime	1 year	X						Firebox & Heat Exchanger
90 Days		X	X	X	X	X	X	All Replacement Parts
See Conditions, Exclusions, and limitations.							9-01-08	

CONDITIONS, EXCLUSIONS & LIMITATION OF LIABILITY

- This warranty applies to the original owner and is transferable up to two years from date of purchase to the new homeowner, provided the purchase was made through an authorized dealer or distributor of HHT, and the appliance remains in its original place of installation.
- The maximum amount recoverable under this warranty is limited to the purchase price of the product.
- In no event shall HHT be liable for any incidental or consequential damages caused by defects in the product.
- Adjustments, regular maintenance, cleaning and temporary repairs, or the failure to duplicate the problem in the home is not covered under this warranty.
- This limited warranty does not extend to or include surface finish on the appliance or terminations, door gasketing, glass gasketing, glass discoloration, firebrick, pellet logs, kaowool or other ceramic insulating materials. Rust and/or corrosion on any of the metal surfaces, cast iron components, baffles, firepots, doors, or firebox area are not covered by this warranty.
- Noise resulting from minor expansion, contraction, or movement of certain parts is normal and complaints related to this noise are not covered by this warranty.

Hearth & Home Technologies LIMITED WARRANTY (Cont'd)

- HHT's obligation under this warranty does not extend to damages resulting from: (1) installation, operation or maintenance of the appliance not in accordance with the installation instructions; operating instructions and the listing agent identification label furnished with the appliance; (2) installation which does not comply with local building codes; (3) shipping, improper handling, improper operation, abuse, misuse, accident or unworkmanlike repairs; (4) environmental conditions, inadequate ventilation or drafting caused by tight sealing construction of the structure or handling devices such as exhaust fans or forced air furnaces or other such causes; (5) use of fuels other than those specified in the operating instructions; (6) installation or use of components not supplied with the appliance or any other components not expressly authorized and approved by HHT; and/or (7) modification of the appliance not expressly authorized and approved by HHT in writing.
- This warranty does not apply to non-HHT venting components, hearth components or other accessories used in conjunction with the installation of this product.
- This warranty is void if the appliance has been over-fired or operated in atmospheres contaminated by chlorine, fluorine, or other damaging chemicals the appliance is subject to prolonged periods of dampness or condensation, or there is any damage to the appliance or other components due to water or weather damage which is the result of, but not limited to, improper chimney or venting installation.
- HHT's liability under this warranty is limited to the replacement and repair of defective components or workmanship during the applicable period. HHT may fully discharge all of its obligations under such warranties by repairing the defective component(s) at HHT's discretion. Shipping costs are not covered under this warranty.
- Some states do not allow exclusions or limitation of incidental or consequential damages, so those limitations may not apply to you. This warranty gives you specific rights; you may also have other rights, which vary from state to state.
- EXCEPT TO THE EXTENT PROVIDED BY LAW, HHT MAKES NO EXPRESS WARRANTIES OTHER THAN THE WARRANTY SPECIFIED HEREIN. THE DURATION OF ANY IMPLIED WARRANTY IS LIMITED TO DURATION OF THE WARRANTY SPECIFIED ABOVE.

This Limited Warranty is effective on all HHT appliances sold after September 01, 2008 and supersedes any and all warranties currently in existence.



If warranty service is needed, you should contact your installing dealer. If the installing dealer is unable to provide necessary parts or components, contact the nearest authorized HHT dealer or supplier.

QUADRA-FIRE®

O T T O T O :

Hearth & Home Technologies
1445 North Highway
Colville, WA 99114
Division of HNI INDUSTRIES

Please contact your Quadra-Fire dealer with any questions or concerns.
For the number of your nearest Quadra-Fire dealer
log onto www.quadrafire.com

	CAUTION
	Do NOT discard this manual. <ul style="list-style-type: none">• Important operating and maintenance instructions included.• Read, understand and follow these instructions for safe installation and operation.• Leave this manual with party responsible for use and operation.

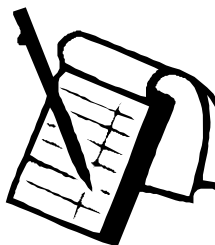

Your Records for Model: CASTILE PELLET STOVE

SERIAL NUMBER: _____

DATE PURCHASED: _____

DATE INSTALLED: _____

WHERE PURCHASED: _____

TELEPHONE: _____

This product may be covered by one or more of the following patents: (United States) 4593510, 4686807, 4766876, 4793322, 4811534, 5000162, 5016609, 5076254, 5113843, 5191877, 5218953, 5263471, 5328356, 5341794, 5347983, 5429495, 5452708, 5542407, 5601073, 5613487, 5647340, 5688568, 5762062, 5775408, 5890485, 5931661, 5941237, 5947112, 5996575, 6006743, 6019099, 6048195, 6053165, 6145502, 6170481, 6237588, 6296474, 6374822, 6413079, 6439226, 6484712, 6543698, 6550687, 6601579, 6672860, 6688302B2, 6715724B2, 6729551, 6736133, 6748940, 6748942, 6769426, 6774802, 6796302, 6840261, 6848441, 6863064, 6866205, 6869278, 6875012, 6880275, 6908039, 6919884, D320652, D445174, D462436; (Canada) 1297749, 2195264, 2225408, 2313972; (Australia) 780250, 780403, 1418504 or other U.S. and foreign patents pending.

