

# QUADRA-FIRE®

## CASTILE PELLET INSERT

### Owner's Manual Installation and Operation

#### Models:

810-02901 (MBK)

810-03201 (PMH)

CASTINS-CSB

CASTINS-CWL



Tested and  
Listed by  Portland  
Oregon USA  
C US  
OMNI-Test Laboratories, Inc.



### CAUTION

#### DO NOT DISCARD THIS MANUAL



- Important operating and maintenance instructions included.
- Read, understand and follow these instructions for safe installation and operation.
- Leave this manual with party responsible for use and operation.



### WARNING



**Please read this entire manual before installation and use of this pellet fuel-burning room heater. Failure to follow these instructions could result in property damage, bodily injury or even death.**

- Do not store or use gasoline or other flammable vapors and liquids in the vicinity of this or any other appliance.
- Do not overfire - If any external part starts to glow, you are overfiring. Reduce feed rate. Overfiring will void your warranty.
- Comply with all minimum clearances to combustibles as specified. Failure to comply may cause house fire.



### WARNING



#### HOT SURFACES!

Glass and other surfaces are hot during operation AND cool down.

#### Hot glass will cause burns.

- Do not touch glass until it is cooled
- NEVER allow children to touch glass
- Keep children away
- CAREFULLY SUPERVISE children in same room as fireplace.
- Alert children and adults to hazards of high temperatures.

#### High temperatures may ignite clothing or other flammable materials.

- Keep clothing, furniture, draperies and other flammable materials away.


### CAUTION

Tested and approved for wood pellets and shelled field corn fuel only. Burning of any other type of fuel voids your warranty.

### CAUTION

Check building codes prior to installation.

- Installation MUST comply with local, regional, state and national codes and regulations.
- Consult local building, fire officials or authorities having jurisdiction about restrictions, installation inspection, and permits.

*Congratulations*   
and Welcome to the Quadra-Fire Family!

Hearth & Home Technologies welcomes you to our tradition of excellence! In choosing a Quadra-Fire appliance, you have our assurance of commitment to quality, durability, and performance.

This commitment begins with our research of the market, including 'Voice of the Customer' contacts, ensuring we make products that will satisfy your needs.

Our Research and Development facility then employs the world's most advanced technology to achieve the optimum operation of our stoves, inserts and fireplaces. And yet we are old-fashioned when it comes to craftsmanship. Each unit is meticulously fabricated and are hand-finished for lasting beauty and enjoyment.


Our pledge to quality is completed as each model undergoes a quality control inspection. From design, to fabrication, to shipping: We wish you and your family many years of enjoyment in the warmth and comfort of your hearth appliance.

Thank you for choosing Quadra-Fire.

**NOTE: Consult insurance carrier, local building inspector, fire officials or authorities having jurisdiction over restrictions, installation inspection and permits.**

**SAMPLE OF CLEARANCE TO COMBUSTIBLES LABEL**  
**LOCATION: On beaded chain behind right access panel. Panel hinges open.**


**SAFETY LABEL**

Tested and Listed by  Portland Oregon USA  
C US  
OMNI-Test Laboratories, Inc.

Report No. #061-S-42-2

**QUADRA-FIRE**  
Castile Pellet Insert


Input Rating: 30,000 BTU/HR.  
Electrical Rating: 115 VAC, 60 Hz, Start 4.1 Amps, Run 1.1 AMPS.

Manufactured by:   
HEARTH & HOME Technologies  
1445 Highway North, Colville, WA 99114  
www.quadrafire.com

Listed Solid Fuel Room Heater/Pellet Type Insert. Also suitable for Mobile Home Installation. This appliance has been tested and listed for use in Manufactured Homes in accordance with OAR 814-23-9000 through 814-23-909.

---

Tested to: ASTM E-1509-95, ULC S628-93, ULC /ORD-C148, M1990 Room Heating Pellet Burning Type, (UM) 84-HUD FOR USE ONLY WITH PELLETTIZED WOOD OR SHELL ED FIELD CORN FUEL.  
Route power cord away from unit. Do not route cord under in front of appliance.



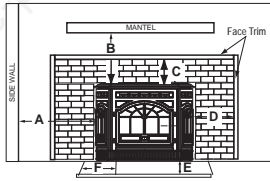
**MINIMUM CLEARANCES TO COMBUSTIBLE MATERIALS AS A BUILT-IN UNIT**

A	Top of Hopper	Top/Rear Vent	0 in. (0mm)
B	Side of Outside Skin	Top/Rear Vent	0 in. (0mm)
C	Back of Hopper	Rear Vent	0 in. (0mm)
		Top Vent	2.5 in. (64mm)
D	Vent Pipe to Combustible	Rear Vent	3.0 in. (76mm)
E	From Panel Edge		0 in. (0mm)

0 in. Clearance To Exposed Section and Face Trim

---


**Masonry or Zero Clearance**



A	Insert side to combustible	0 in.	0mm
B	Insert top to mantel	12 in.	305mm
C	Insert top to face trim	0 in.	0mm
D	Insert side face trim	0 in.	0mm
E	Hearth extension from door opening	6 in.	152mm
F	Hearth extension from side of door opening	6 in.	152mm


**DO NOT REMOVE THIS LABEL**      7014-143

**SAMPLE OF SERIAL NUMBER & DATE OF MANUFACTURE LABEL**  
**LOCATION: Inside hopper on the top**



**CAUTION:** HOT WHILE IN OPERATION DO NOT TOUCH. KEEP CHILDREN, CLOTHING AND FURNITURE AWAY. CONTACT MAY CAUSE SKIN BURNS. SEE NAMEPLATE AND INSTRUCTIONS. Operate this unit with fuel hopper lid closed. Failure to do so may result in emissions products' combustion from the hopper under certain conditions. Maintain hopper seal in good condition. Do not overfill hopper.

**ATTENTION:** CHAUD LORS DE L'OPERATION. NE PAS TOUCHER. GARDEZ LES ENFANTS ET LES VÊTEMENTS LOIN DE L'ESPACE DESIGNÉ DE L'INSTALLATION. LE CONTACT PEUT CAUSER DES BRÛLURES À LA PEAU. VOIR L'ÉTIQUETTE ET LES INSTRUCTIONS. Opérez cet appareil avec le couvercle de la trémie fermé. Le défaut de ne pas suivre les instructions peut résulter, sous certaines conditions, en une combustion des émissions des produits venant de la trémie. Ne pas remplir la trémie trop pleine.

Tested and Listed by  Portland Oregon USA  
C US  
OMNI-Test Laboratories, Inc.

Report / Rapport #061-S-42-2

**QUADRA-FIRE** **CASTILE PELLET INSERT**

Made in U.S.A. U.S. ENVIRONMENTAL PROTECTION AGENCY

NE PAS ENLEVER L'ÉTIQUETTE Fait Aux États-Unis This model is exempt from EPA certification under 40 CFR 60.531 by definition [Wood Heater (A) 'Air-to-Fuel Ratio']

SERIAL NO. / NUMÉRO DU SÉRIE

007

2009 2010 2011

JAN FEB MAR APR MAY JUNE JULY AUG SEPT OCT NOV DEC

DO NOT REMOVE THIS LABEL

250-7262F

Test Lab & Rpt Nbr.

Mfg Date

Model Name

Serial No.

**Safety Alert Key:**

- **DANGER!** Indicates a hazardous situation which, if not avoided will result in death or serious injury.
- **WARNING!** Indicates a hazardous situation which, if not avoided could result in death or serious injury.
- **CAUTION!** Indicates a hazardous situation which, if not avoided, could result in minor or moderate injury.
- **NOTICE:** Indicates practices which may cause damage to the fireplace or to property.

**TABLE OF CONTENTS**

**Section 1: Listing and Code Approvals**

- A. Appliance Certifications .....4
- B. Mobile Home Approved .....4
- C. Glass Specifications.....4
- D. Electrical Rating .....4
- E. BTU & Efficiency Specifications .....4

**Section 2: Getting Started**

- A. Design, Installation & Location Considerations.....5
- B. Locating Your Appliance & Chimney ..6
- C. Draft.....6
- D. Negative Pressure .....6
- E. Fire Safety .....7
- F. Tools & Supplies Needed .....7
- G. Inspect Appliance, Components and Pre-Use Check List.....7

**Section 3: Dimensions & Clearances**

- A. Appliance Dimensions .....8
- B. Clearances to Combustibles As A Built-In, UL and ULC .....9
- C. Clearances to Combustibles, Masonry & Zero Clearance.....10
- D. Floor Protection .....10
- E. Minimum Opening for Factory-Built Fireplace .....10
- F. Removing Floor of Factory-Built Fireplace .....11
- G. Prefabricated Metal Chimney.....12
- H. Altering Factory-Built Fireplace.....12

**Section 4: Vent Information**

- A. Chimney & Exhaust Connections .....13
- B. Venting Termination Requirements ....13
- C. Equivalent Feet of Pipe.....14
- D. Pipe Selection Chart.....14

**Section 5: Venting Systems**

- A. Full Reline with Outside Air-Horizontal 15
- B. Full Reline with Outside Air-Vertical....16

**Section 6: Mobile Home.....17**

**Section 7: Appliance Set-Up**

- A. Reversible Top & Rear Flue Adapter ....18
- B. Leveling System .....18
- C. Outside Air Kit.....19
- D. Zero Clearance Trim Support .....19-20
- E. Panel Set & Cast Trim .....21
- F. Panel & Trim Set Econo .....21
- G. Log Set Placement.....22
- H. Thermostat Installation .....23

**Section 8: Operating Instructions**

- A. Fuel Size, Material & Storage .....24
- B. General Operation Information .....25
- C. Before Your First Fire .....25
- D. Starting Your First Fire.....25
- E. Fire Characteristics.....25
- F. Feed Rate Adjustment .....26
- G. Ignition Cycles .....26
- H. Frequently Asked Questions.....27

**Section 9: Troubleshooting .....28-30**

**Section 10: Maintaining & Servicing Appliance**

- A. Proper Shutdown Procedures.....31
- B. Quick Reference Maintenance Chart..31
- C. General Maintenance & Cleaning .....32-35
- D. High Ash Content Maintenance .....35
- E. Igniter Replacement.....36
- F. Glass Replacement.....36
- G. Baffle & Brick Removal .....37-38

**Section 12: Reference Material**

- A. Component Functions.....39-40
- B. Component Locations.....41
- C. Exploded Drawing.....42
- D. Service Parts & Accessories.....43-47
- E. Service & Maintenance Log .....48-49
- F. Warranty Policy .....50-51
- G. Contact Information.....52

# 1

## Listing and Code Approvals

### A. Appliance Certification

<b>MODEL:</b>	Castile Pellet Insert
<b>LABORATORY:</b>	OMNI Test Laboratories, Inc
<b>REPORT NO.</b>	061-S-42-2
<b>TYPE:</b>	Solid Fuel Room Heater/Pellet Fuel Burning Type Insert
<b>STANDARD:</b>	ASTM E1509-95, ULC S628-93 and ULC/ORD-C1482-M1990 Room Heater Pellet Fuel Burning Type and (UM) 84-HUD, Mobile Home Approved
<b>Colorado:</b>	Approved 11-15-02

### B. Mobile Home Approved

This appliance is approved for mobile home installations when not installed in a sleeping room and when an outside combustion air inlet is used.

The structural integrity of the mobile home floor, ceiling, and walls must be maintained.

The appliance must be properly grounded to the frame of the mobile home and use only Listed pellet vent Class "L" or "PL" connector pipe.

A Quadra-Fire Outside Air Kit must be installed in a mobile home installation. You must order the Outside Air Kit separately.

**Note: The appliance is also approved for installation into a shop.**

### C. Glass Specifications

This appliance is equipped with 5mm ceramic glass. Replace glass only with 5mm ceramic glass. Please contact your dealer for replacement glass.

**NOTE:** This installation must conform with local codes. In the absence of local codes you must comply with the **ASTM E1509-95, ULC S628-93, ULC/ORD-C-1482-M1990 and (UM) 84-HUD**

### D. Electrical Rating

115 VAC, 60 Hz, Start 4.1 Amps, Run 1.1 Amps

### E. BTU & Efficiency Specifications

<b>Particulate Emissions Rating:</b>	0.7 grams/hr
<b>*BTU Output:</b>	8,000 - 30,000 / hr
<b>Heating Capacity:</b>	up to 1,500 sq. ft. depending on climate zone
<b>Hopper Capacity:</b>	45 lbs
<b>Fuel:</b>	Wood Pellets or Shelled Corn
<b>Shipping Weight:</b>	260 lbs

\*BTU output will vary, depending on the brand of fuel you use in your appliance. Consult your Quadra-Fire dealer for best results.

**WARNING! Risk of Fire!** *Hearth & Home Technologies disclaims any responsibility for, and the warranty and agency listing will be voided by the above actions.*

**DO NOT:**

- Install or operate damaged appliance
- Modify appliance
- Install other than as instructed by *Hearth & Home Technologies*
- Operate the appliance without fully assembling all components
- Overfire
- Install any component not approved by *Hearth & Home Technologies*
- Install parts or components not Listed or approved.

*Improper installation, adjustment, alteration, service or maintenance can cause injury or property damage.*

*For assistance or additional information, consult a qualified installer, service agency or your dealer.*

**NOTE:** *Hearth & Home Technologies, manufacturer of this appliance, reserves the right to alter its products, their specifications and/or price without notice.*

Quadra-Fire is a registered trademark of *Hearth & Home Technologies.*

# 2

## Getting Started

### A. Design, Installation & Location Considerations

#### 1. Appliance Location

**NOTICE:** Check building codes prior to installation.

- Installation MUST comply with local, regional, state and national codes and regulations.
- Consult insurance carrier, local building inspector, fire officials or authorities having jurisdiction over restrictions, installation inspection and permits.

It is a good idea to plan your installation on paper, using exact measurements for clearances and floor protection, before actually beginning the installation

Consideration must be given to:

- Safety, convenience, traffic flow
- Placement of the chimney and chimney connector.
- If you are not using an existing chimney, place the appliance where there will be a clear passage for a factory-built listed chimney through the ceiling and roof.
- Installing an optional outside air kit would affect the location of the vent termination.

Since pellet exhaust can contain ash, soot or sparks, you must consider the location of:

- Windows
- Air Intakes
- Air Conditioner
- Overhang, soffits, porch roofs, adjacent walls
- Landscaping, vegetation

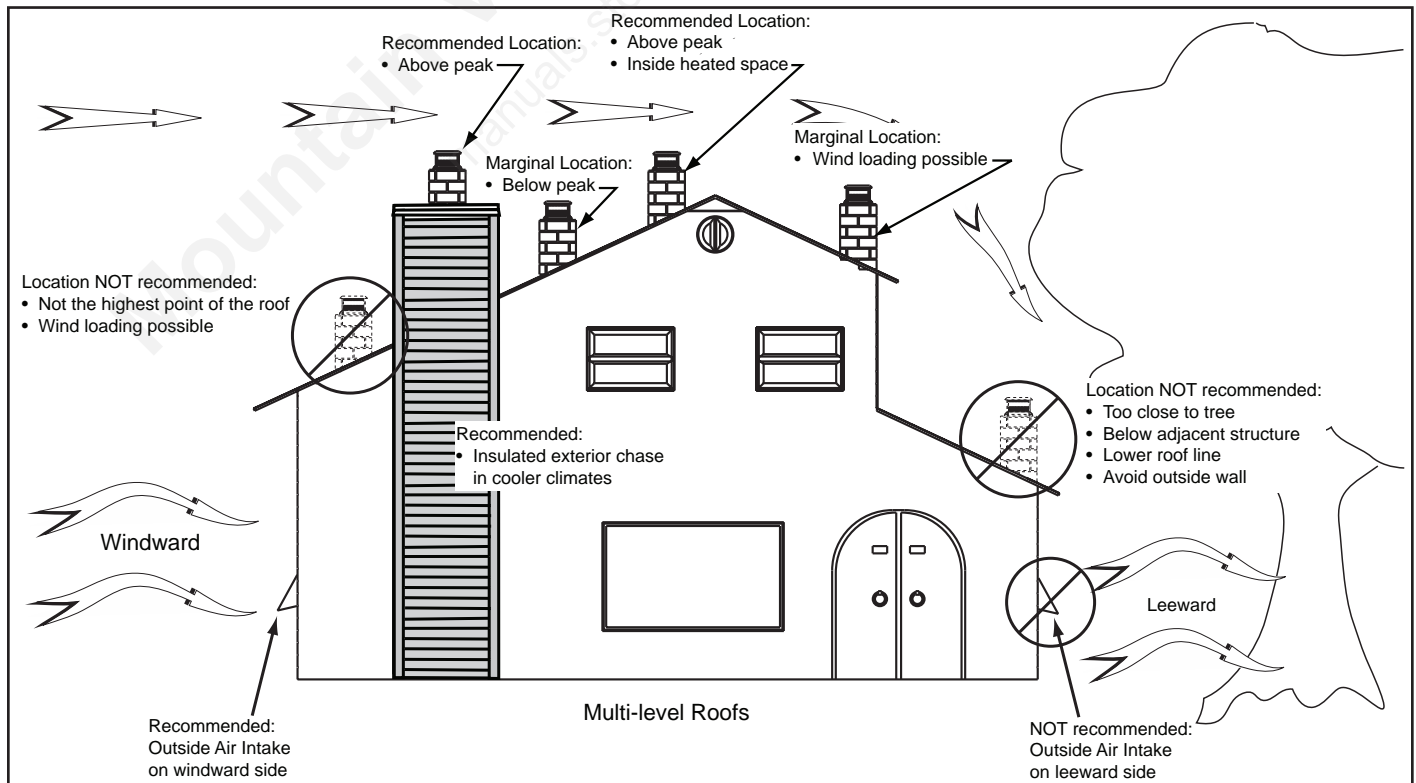
When locating vent and venting termination, vent above roof line when possible.

**Warning! Risk of Fire** Damaged parts could impair safe operation. Do NOT install damaged, incomplete or substitute components.

**CAUTION!** If burning shelled field corn, you must use approved venting specifically designed for corn to prevent corrosion or degradation. Follow the instructions from the venting manufacturer.

**NOTICE:** Locating the appliance in a location of considerable air movement can cause intermittent smoke spillage from appliance. Do not locate appliance near:

- Frequently open doors
- Central heat outlets or returns



**Figure 5.1**

## B. Locating Your Appliance & Chimney

Location of the appliance and chimney will affect performance.

- Install through the warm airspace enclosed by the building envelope. This helps to produce more draft, especially during lighting and die-down of the fire.
- Penetrate the highest part of the roof. This minimizes the effects of wind loading.
- Locate termination cap away from trees, adjacent structures, uneven roof lines and other obstructions.
- Minimize the use of chimney offsets.
- Consider the appliance location relative to floor and ceiling and attic joists.



### CAUTION

- DO NOT CONNECT THIS UNIT TO A CHIMNEY FLUE SERVICING ANOTHER APPLIANCE.
- DO NOT CONNECT TO ANY AIR DISTRIBUTION DUCT OR SYSTEM.

## C. Draft

Draft is the pressure difference needed to vent appliances successfully. When an appliance is drafting successfully, all combustion byproducts are exiting the home through the chimney.

Considerations for successful draft include:

- Preventing negative pressure
- Location of appliance and chimney

**NOTICE:** *Hearth & Home Technologies assumes no responsibility for the improper performance of the chimney system caused by:*

- *Inadequate draft due to environmental conditions*
- *Downdrafts*
- *Tight sealing construction of the structure*
- *Mechanical exhausting devices*

## D. Negative Pressure

**WARNING! Risk of Asphyxiation!** *Negative pressure can cause spillage of combustion fumes and soot.*

Negative pressure results from the imbalance of air available for the appliance to operate properly. It can be strongest in lower levels of the house.

Causes include:

- Exhaust fans (kitchen, bath, etc.)
- Range hoods
- Combustion air requirements for furnaces, water heaters and other combustion appliances
- Clothes dryers
- Location of return-air vents to furnace or air conditioning
- Imbalances of the HVAC air handling system
- Upper level air leaks such as:
  - Recessed lighting
  - Attic hatch
  - Duct leaks

To minimize the effects of negative air pressure:

- Install the outside air kit with the intake facing prevailing winds during the heating season
- Ensure adequate outdoor air for all combustion appliances and exhaust equipment
- Ensure furnace and air conditioning return vents are not located in the immediate vicinity of the appliance
- Avoid installing the appliance near doors, walkways or small isolated spaces
- Recessed lighting should be a “sealed can” design
- Attic hatches weather stripped or sealed
- Attic mounted duct work and air handler joints and seams taped or sealed

**E. Fire Safety**



To provide reasonable fire safety, the following should be given serious consideration:



- Install at least one smoke detector on each floor of your home.
- Locate smoke detector away from the heating appliance and close to the sleeping areas.
- Follow the smoke detector manufacturer’s placement and installation instructions and maintain regularly.
- Conveniently locate a Class A fire extinguisher to contend with small fires.
- In the event of a hopper fire:
  - Evacuate the house immediately.
  - Notify fire department.

**F. Tools And Supplies Needed**

<b>Tools and building supplies normally required for installation, unless installing into an existing masonry fireplace:</b>	
Reciprocating Saw	Safety Glasses
Hammer	Framing Square
Phillips Screw driver	Electric Drill & Bits (1/4")
Tape Measure	1/4" Self-Tapping Screws
Plumb Line	
Level	<u>May also need:</u>
Framing Material	Vent Support Straps
Hi-temp Caulking Material	Venting Paint
Gloves	

**G. Inspect Appliance & Components and Pre-Use Check List**

	 <b>WARNING</b>
Inspect appliance and components for damage. Damaged parts may impair safe operation.	
<ul style="list-style-type: none"> <li>• Do NOT install damaged components.</li> <li>• Do NOT install incomplete components.</li> <li>• Do NOT install substitute components.</li> </ul>	
Report damaged parts to dealer.	

	 <b>WARNING</b>
<b>Fire Risk.</b>	
Hearth & Home Technologies disclaims any responsibility for, and the warranty will be voided by, the following actions:	
<ul style="list-style-type: none"> <li>• Installation and use of any damaged appliance.</li> <li>• Modification of the appliance.</li> <li>• Installation other than as instructed by Hearth &amp; Home Technologies.</li> <li>• Installation and/or use of any component part not approved by Hearth &amp; Home Technologies.</li> <li>• Operating appliance without fully assembling all components.</li> <li>• Do NOT Overfire.</li> </ul>	
<b>Or any such action that may cause a fire hazard.</b>	

1.	✓	Place the appliance in a location near the final installation area and follow the procedures below:
2.		Open the appliance and remove all the parts and articles packed inside the Component Pack. Inspect all the parts and glass for shipping damage. Contact your dealer if any irregularities are noticed.
3.		All safety warnings have been read and followed.
4.		This Owner’s Manual has been read.
5.		Floor protection requirements have been met.
6.		Venting is properly installed.
7.		The proper clearances from the appliance and chimney to combustible materials have been met.
8.		The masonry chimney is inspected by a professional and is clean, or the factory built metal chimney is installed according to the manufacturer’s instructions and clearances.
9.		The chimney meets the required minimum height.
10.		All labels have been removed from the glass door.
11.		Plated surfaces have been wiped clean, if applicable.
12.		Thermostat or remote has been installed.
13.		A power outlet is available nearby.
14.		A good quality surge protection is highly recommended to protect the electronics.

# 3 Dimensions and Clearances

## A. Appliance Dimensions

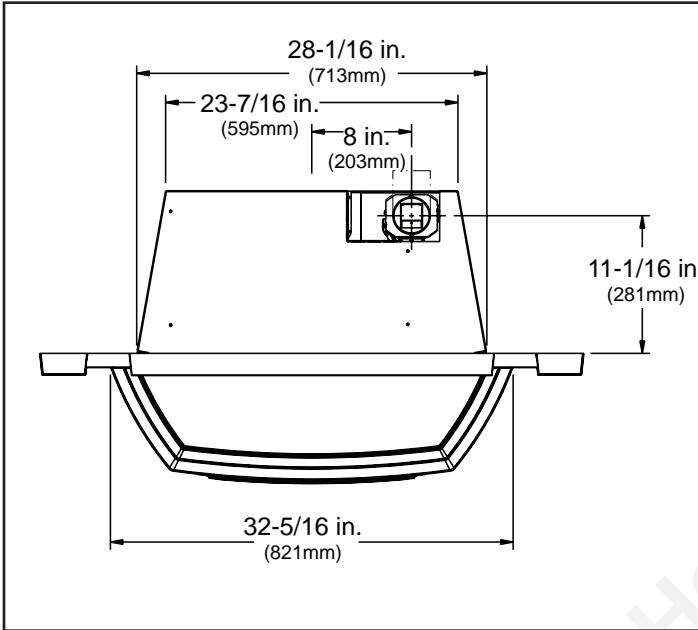


Figure 8.1 - Top View

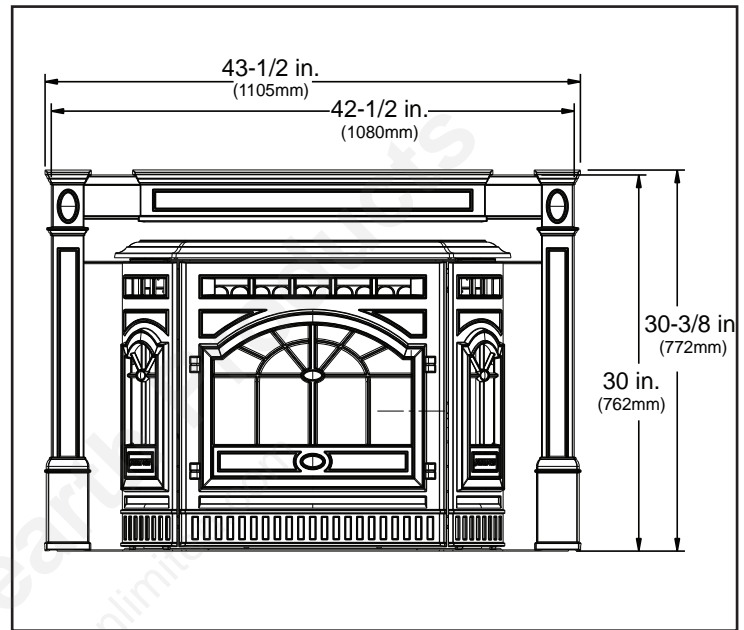


Figure 8.2- Front View

Panel Size	Height		Width	
	inch	mm	inch	mm
Small Cast	30	762	42-1/2	1078
Large Cast	34	864	48	1219
Small Econo	30	762	40	1016

**NOTE:** All views are shown with Panel & Cast Trim Set installed.

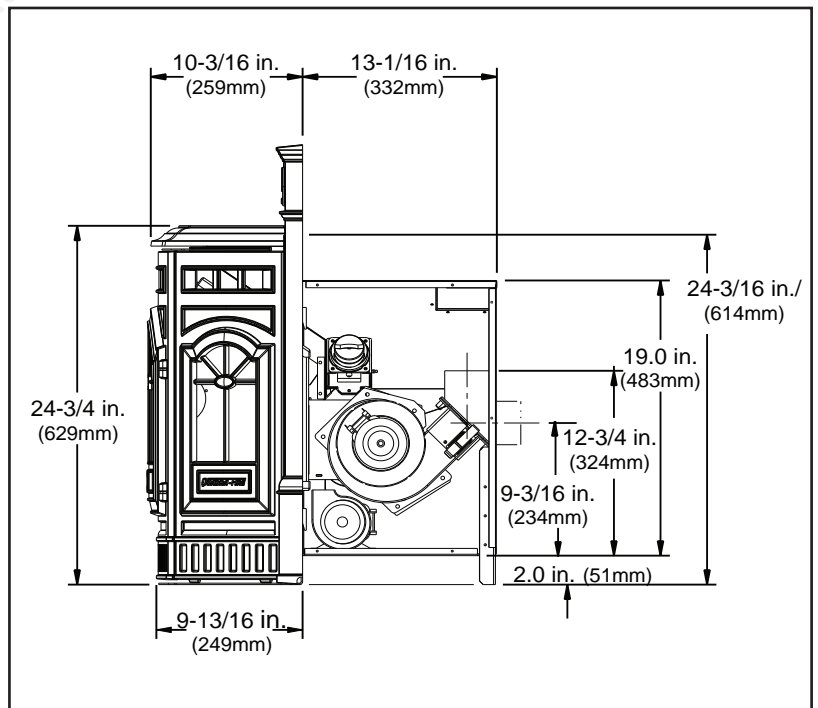
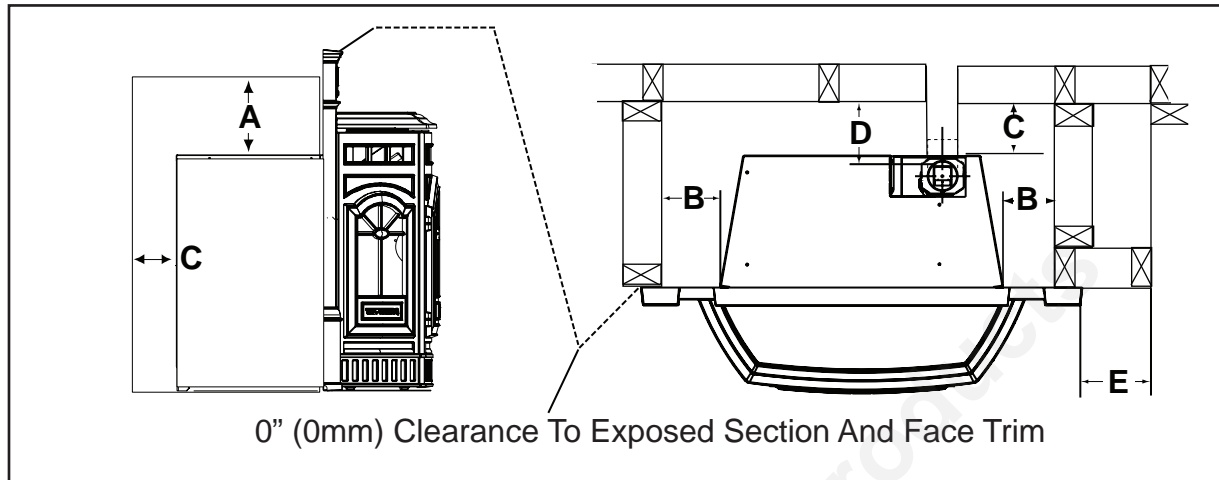


Figure 8.3 -Side View

**B. Clearance To Combustibles, UL and ULC**

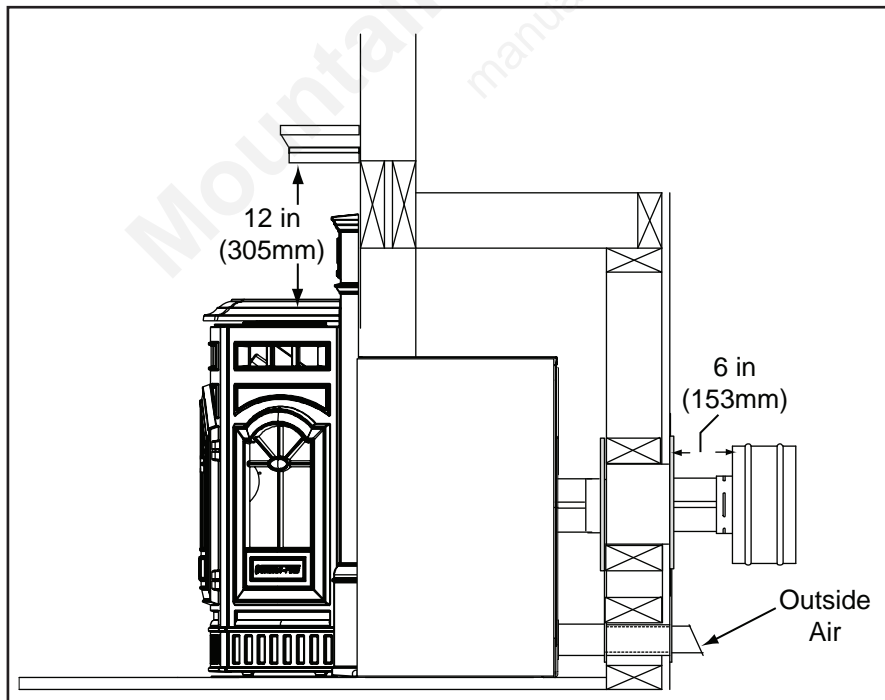
**AS A BUILT-IN**



**Figure 9.1**


			Inches	Millimeters
A	Top of Hopper	Top or Rear Vent	0	0
B	Side of Outside Skin	Top or Rear Vent	0	0
C	Back of Hopper	Top Vent	2.5	64
		Rear Vent	0	0
D	Vent Pipe to Combustible	Top or Rear Vent	3.0	76
E	Front Panel Edge	Top or Rear Vent	0	0

**INSTALLED AS A BUILT-IN UNIT**  
**Shown Optional Outside Air**



**Figure 9.2**

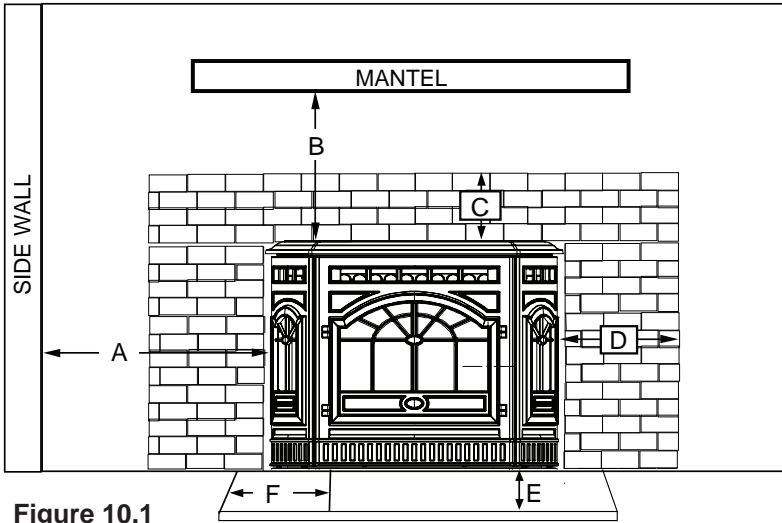
**WARNING**

 Fire Risk.  
Comply with all minimum clearances to combustibles as specified.  
Failure to comply may cause house fire.

**NOTE:**

- Illustrations reflect typical installations and are FOR DESIGN PURPOSES ONLY.
- Illustrations/diagrams are not drawn to scale.
- Actual installation may vary due to individual design preference.

**C. Masonry and Zero Clearance Fireplaces**



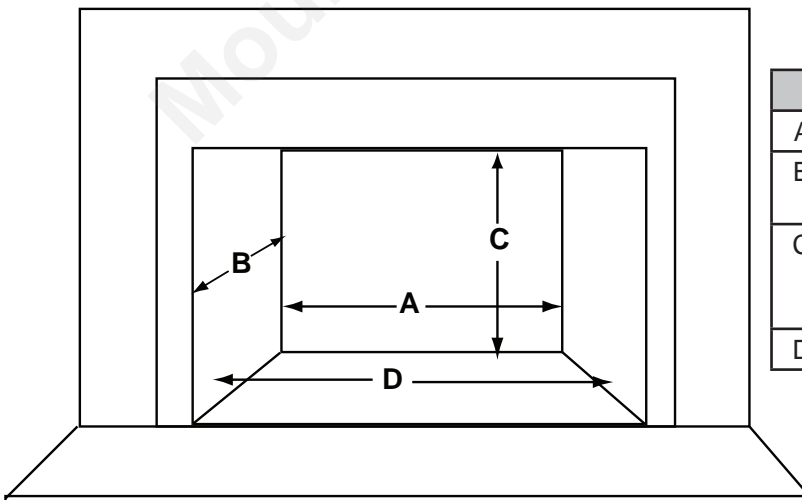
		Inches	Millimeters
A	Insert side to combustible side wall	0	0
B	Insert top to mantel	12	305
C	Insert top to face trim	0	0
D	Insert side to face trim	0	0

Figure 10.1

**D. Floor Protection**

		Inches	Millimeters
E	Floor protection hearth extension from door opening	6	152
F	Floor protection to the side of door opening	6	152

**E. Minimum Opening for Masonry and Zero Clearance Fireplaces**



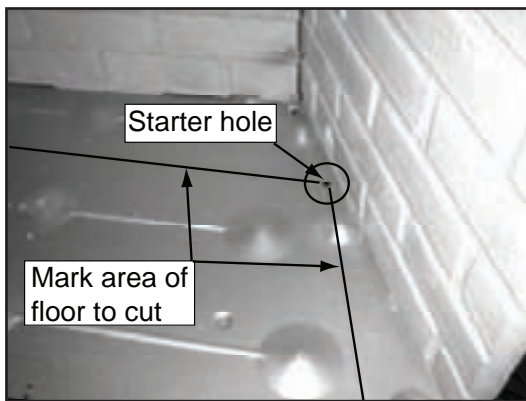
	Location	Inches	Millimeters
A	Rear Width	23-7/16	595
B	Depth	18 for Zero Clearance 14 for Masonry	457 356
C	Height	19-1/4 if drop down 21-1/4 if flush or hearth mount	489 540
D	Front Width	28-1/4	718

Figure 10.2

**F. Removing Metal Floor of Factory-Built Firebox**

- The firebrick (refractory), glass doors, screen rails, screen mesh and log grates can be removed from a factory-built firebox in order to gain minimum insert opening requirements.
- Any smoke shelves, shields and baffles may be removed from a factory-built firebox if attached with mechanical fasteners.
- The metal floor of the factory-built firebox may be removed to facilitate the installation of the insert only when a 1/4 (6mm) inch airspace is provided between the insert and the floor of outer wrap.

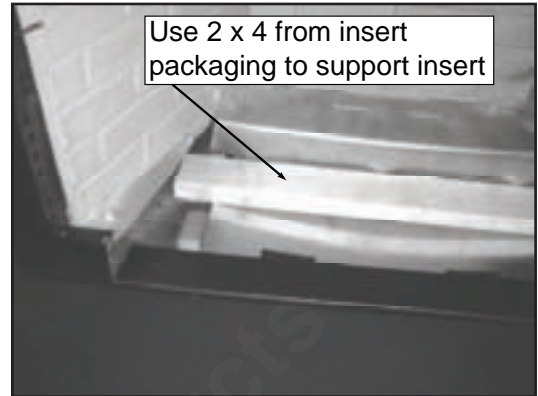
The following is only one example as there are many different models of factory-built fireplaces.



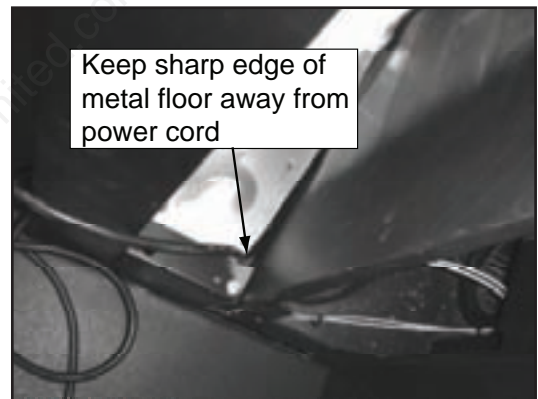
**Figure 11.1.** Measure and mark the metal floor for cutting. With a drill, make a starter hole in each corner.



**Figure 11.2.** Using a saws-all, cut out the floor



**Figure 11.3.** If the floor is made of thin metal, we recommend using the 2 x 4 from the insert packaging to support the insert. The 2 x 4 may need to be cut to the appropriate size.



**Figure 11.4.** Place the insert into the factory-built firebox. Ensure that the power cord can not be damaged by the sharp metal edge. You may need to cut out a notch to accommodate the cord.

**NOTE:** Ensure that the leveling leg is positioned over the 2 x 4 before leveling the insert. See **page 18**, for detailed instructions on how to adjust the leveling legs.

**G. Prefabricated Metal Chimney**

The chimney can be new or existing, masonry or prefabricated and must meet the following minimum requirements:

- Must be minimum 6 inch (152mm) inside diameter of high temperature chimney listed to UL 103 HT (2100°F) or ULC-S628.
- Must use components required by the manufacturer for installation.
- Must maintain clearances required by the manufacturer for installation.
- Refer to manufacturers instructions for installation
- This insert is listed to UL 1482 Standard and is approved for installation into listed factory-built zero clearance fireplaces listed to UL 127 conforming to the following specifications and instructions:
- The original factory-built clearance fireplace chimney cap must be re-installed after installing the approved chimney liner meeting type UL 103 HT requirements (2100°F) per UL 1777.
- If the chimney is not listed as meeting HT requirements, or if the factory built fireplace was tested prior to 1998, a full height listed chimney liner must be installed from the appliance flue collar to the chimney top.
- The liner must be securely attached to the insert flue collar and the chimney top.
- The air flow of the factory-built zero-clearance fireplace system must not be altered. The flue liner top support attachment must not reduce the air flow for the existing air-cooled chimney system.
- No dilution air is allowed to enter the chimney.
  1. Secure the fireplace damper in the open position. If this cannot be accomplished, it will be necessary to remove the damper
  2. Seal damper area of chimney around chimney connector with a high temperature sealant or seal insert against the face of the fireplace.
  3. Both methods must be removable and replaceable for cleaning and re-installation.

**H. Altering the Factory-Built Fireplace**

- The fireplace must not be altered, except for the exceptions listed below. Do not removal the bricks and mortar from the existing fireplace.

The following modifications are permissible:

- Removal of damper or locked in open position
- Removal of smoke shelf or baffle
- Removal of ember catches
- Removal of fire grate
- Removal of view screen/curtain
- Removal of doors
- External trim pieces which do not affect the operation of the fireplace may be removed providing they can be stored on or within the fireplace for reassembly if the insert is removed.
- The permanent metal warning label provided must be attached to the back of the fireplace, with screws or nails, stating that the fireplace may have been altered to accommodate the insert, and must be returned to original condition for use as a conventional fireplace. **Figure 11.1**
- If the hearth extension is lower than the fireplace opening, the portion of the insert extending onto the hearth must be supported.
- Manufacturer designed adjustable support kit can be ordered from your dealer.
- Final approval of this installation type is contingent upon the authority having jurisdiction.

**NOTE: Refer to chimney liner manufacturer for recommendations on supporting the liner. Installation into fireplaces without a permit will void the listing**

**WARNING! Risk of Fire!**

*Follow venting manufacturer’s clearances and instructions when installing venting system.*

**NOTICE:** In Canada when using a factory-built chimney it must be safety listed, **Type UL103 HT (2100°F) [1149°C] CLASS “A”** or conforming to **CAN/ULC-S629M, STANDARD FOR 650°C FACTORY-BUILT CHIMNEYS.**

**WARNING**

THIS FIREPLACE MAY HAVE BEEN ALTERED TO ACCOMMODATE AN INSERT. IT MUST BE RETURNED TO ITS ORIGINAL CONDITION BEFORE USE AS A SOLID FUEL BURNING FIREPLACE.

250-2061

**Figure 121**



# 4 Vent Information



## A. Chimney and Exhaust Connection

1. **Chimney & Connector:** Use 3 or 4 inch (76-102mm) diameter type "L" or "PL" venting system. It can be vented vertically or horizontally.
2. **Mobile Home:** Approved for all Listed pellet vent. If using the 3 inch (76mm) vertical Top Vent Adapter Kit or the 3 to 6 inch (76-152mm) Top Vent Offset Adapter, use Listed double wall flue connector. A Quadra-Fire Outside Air Kit must be used with manufactured home installations.
3. **Residential:** The 3 inch (76mm) vertical Top Vent Adapter Kit and the 3 to 6 inch (76-152mm) Top Vent Offset Adapter are tested to use 24 gauge single wall flue connector or Listed double wall flue connector to Class A Listed metal chimneys, or masonry chimneys meeting International Conference of Building Officials (ICBO) standards for solid fuel appliances.
4. **INSTALL VENT AT CLEARANCES SPECIFIED BY THE VENT MANUFACTURER.**
5. Secure exhaust venting system to the appliance with at least 3 screws. Also secure all connector pipe joints with at least 3 screws through each joint.
6. **DO NOT INSTALL A FLUE DAMPER IN THE EXHAUST VENTING SYSTEM OF THIS UNIT.**
7. **DO NOT CONNECT THIS UNIT TO A CHIMNEY FLUE SERVING ANOTHER APPLIANCE.**

**NOTE: All pipe must be welded seam pipe whenever possible. Seal pipe joints with high temperature silicone (500°F [260°C] minimum rated only). Do not put silicone inside of pipe.**

**NOTE: If burning shelled field corn, you must use approved venting specifically designed for corn. Follow the instructions from the venting manufacturer.**

	<b>WARNING</b>
	<p>Fire Hazard.</p> <ul style="list-style-type: none"> <li>• Only LISTED venting components may be used.</li> <li>• NO OTHER vent components may be used. Substitute or damaged vent components may impair safe operation.</li> </ul>

	<b>WARNING</b>
	<p>Vent surfaces get HOT, can cause burns if touched. Noncombustible shielding or guards may be required.</p>

## B. Venting Termination Requirements

<b>CAUTION</b>
<p><b>Do not terminate vent</b> in any enclosed or semi-enclosed area such as a carport, garage, attic, crawl space, under a sun deck or porch, narrow walkway or closely fenced area, or any location that can build up a concentration of fumes such as a stairwell, covered breezeway, etc.</p>

1. Termination must exhaust above air inlet elevation. It is recommended that at least 60 inches (1.5m) of vertical pipe be installed when appliance is vented directly through a wall. This will create a natural draft, which will help prevent the possibility of smoke or odor venting into the home during a power outage. It will also keep exhaust from causing a nuisance or hazard by exposing people or shrubs to high temperatures. The safest and preferred venting method is to extend the vent vertically through the roof.
2. Distance from doors and opening windows, or gravity or ventilation air inlets into building:
  - a. Not less than 48 inches (1.2m) below;
  - b. Not less than 48 inches (1.2m) horizontally from;
  - c. Not less than 12 inches (305mm) above.
3. Distance from permanently closed windows:
  - a. Not less than 12 inches (305mm) below, horizontally from or above.
4. Distance between bottom of termination and grade should be 12 inches (305mm) minimum. This is conditional upon plants in the area, and nature of grade surface. The grade surface must be a non-combustible material (i.e., rock, dirt). The grade surface must not be lawn. Distance between bottom of termination and public walkway should be 84 inches (2.13m) minimum.
5. Distance to combustible materials must be 24 inches (610mm) minimum. This includes adjacent buildings, fences, protruding parts of the structure, roof overhang, plants and shrubs, etc.
6. Termination Cap Location (Home Electrical Service)
  - Side-to-side clearance is to be the same as minimum clearance to vinyl inside corners.
  - Clearance of a termination cap below electrical service shall be the same as minimum clearance to vinyl soffits.
  - Clearance of a termination cap above electrical service will be 12 inches (305mm) minimum.
  - Location of the vent termination must not obstruct or interfere with access to the electrical service.

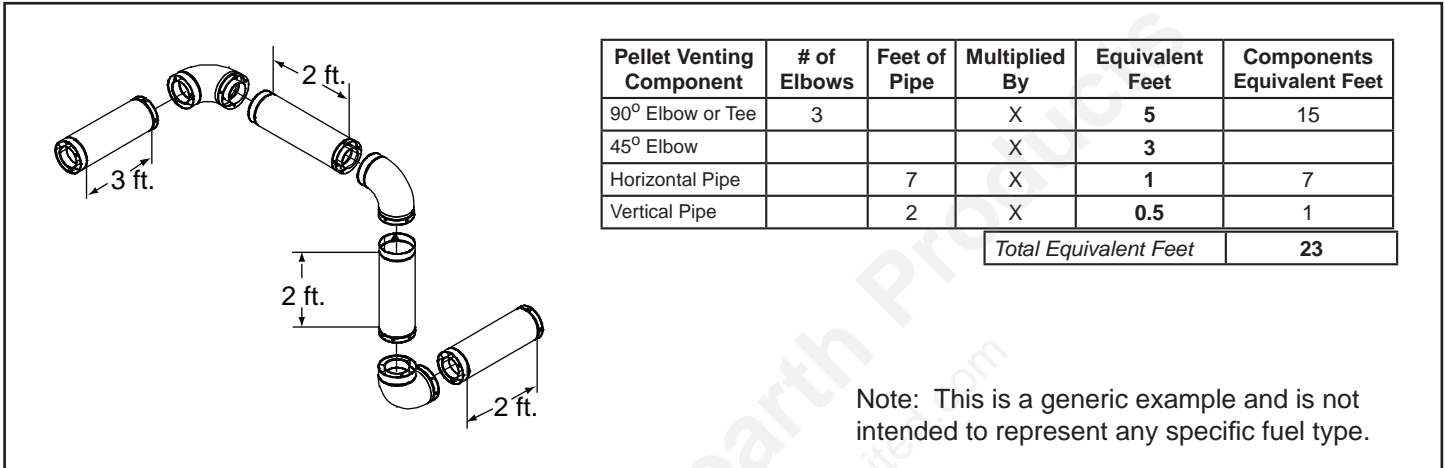
**C. Equivalent Feet of Pipe**

The table below can help you calculate the equivalent feet of pipe which is a method used to determine pellet vent size. **Figure 14.1.**

**WARNING**

Improper installation, adjustment, alteration, service or maintenance can cause injury or property damage. Refer to the owner's information manual provided with this appliance. For assistance or additional information consult a qualified installer, service agency or your dealer.

**Example of 3 Elbow-Rear Vent Termination Calculation**



Note: This is a generic example and is not intended to represent any specific fuel type.

Figure 14.1

**D. Pipe Selection Chart**

The chart will help you in determining proper venting size according to the equivalent feet of pipe calculated above and the altitude above sea level of this installation. **Figure 14.2.**

Locate the calculated equivalent feet of pipe on the vertical left side of the chart. Move to the right horizontally on the chart until you reach your altitude above sea level.

If you fall below the diagonal line, 3 or 4 inch (76 to 102mm) pipe may be used. If it is anywhere above the diagonal line, a 4 inch (102mm) diameter pipe is required.

The chart reveals that a 90° elbow is 5 times as restrictive to the flow of exhaust gases under positive pressure as 1 foot of horizontal pipe, and a foot of horizontal pipe is twice as restrictive as a foot of vertical pipe.

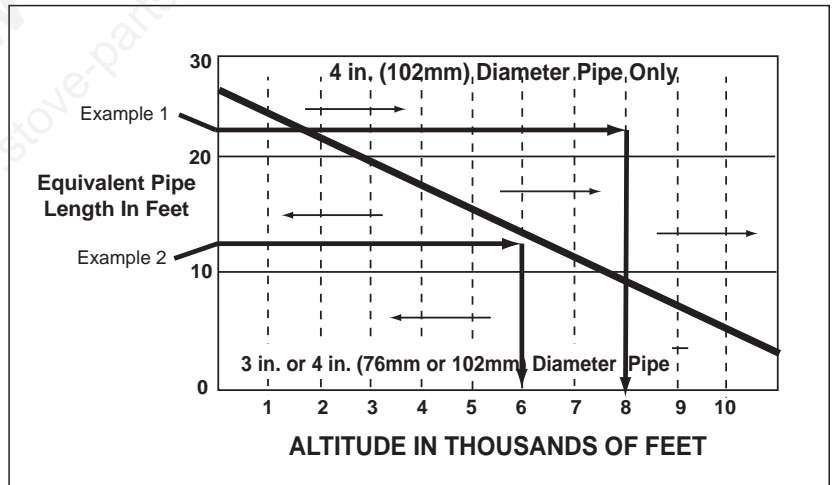


Figure 14.2

**Example 1:** If the equivalent length of pipe is 23 feet with altitude of 8,000 feet you must use 4 inch (102mm) diameter type "L" or "PL" vent.

**Example 2:** If the equivalent length of pipe is 12 feet with altitude of 6,000 feet you may use 3 or 4 inch (76 to 102mm) diameter type "L" or "PL" vent

# 5 Venting Systems

## A. Full Reline With Outside Air - Horizontal

### CAUTION

- Never draw outside combustion air from:
- Wall, floor or ceiling cavity
  - Enclosed space such as an attic or garage



### WARNING



- Fire Risk.
- Inspection of Chimney:
- Masonry chimney must be in good condition.
  - Meets minimum standard of NFPA 211
  - Factory-built chimney must be a minimum 6 inch (152mm) UL103 HT.

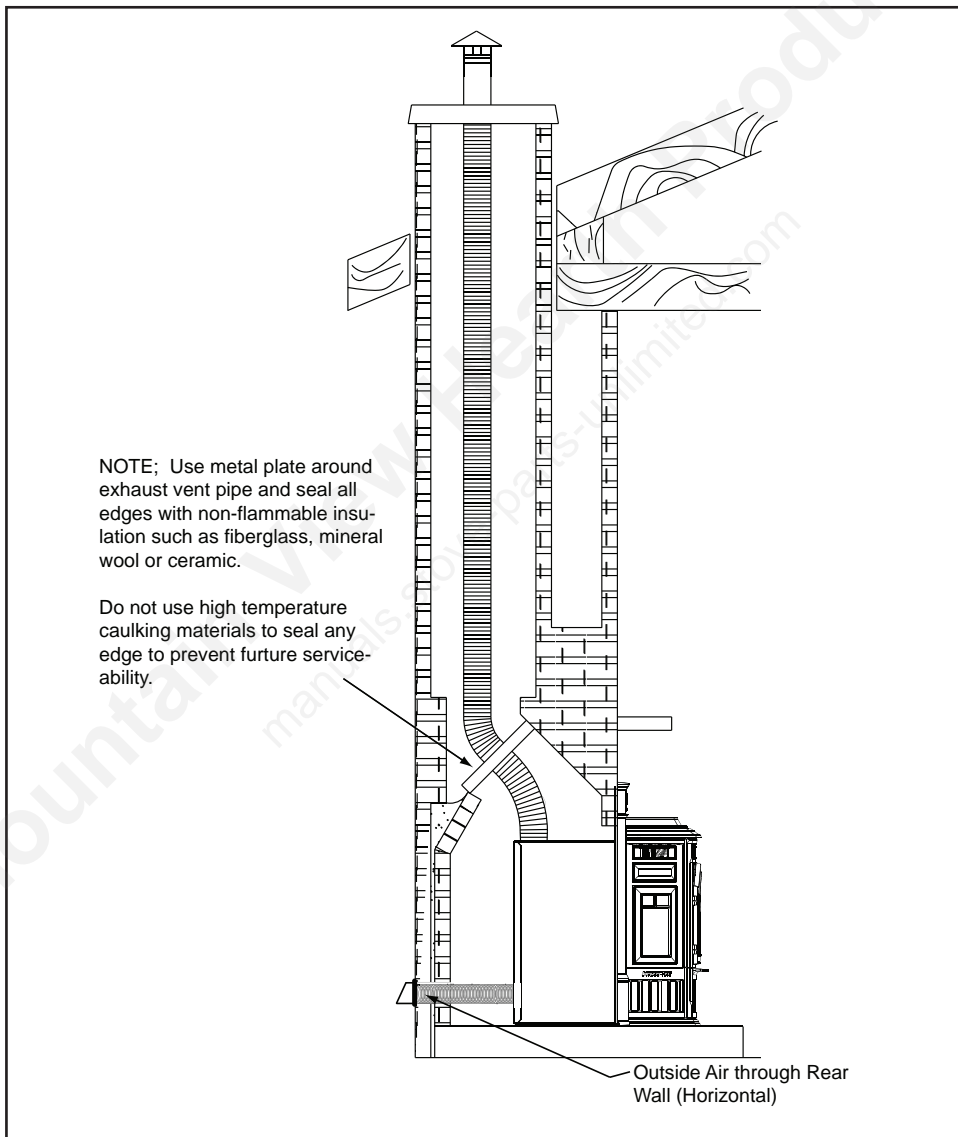


Figure 15.1

#### NOTE:

In Canada, where passage through a wall or partition of combustible construction is desired, the installation shall conform to CAN/CSA-B365.

#### NOTE:

- Illustrations reflect typical installations and are FOR DESIGN PURPOSES ONLY.
- Illustrations/diagrams are not drawn to scale.
- Actual installation may vary due to individual design preference.

**B. Full Reline With Outside Air - Vertical**

**NOTE:** Check clearances carefully for this type of installation to ensure adequate room for outside air venting.

**NOTE:** In Canada only a full reline is allowed per ULC S628, ORD ULC C1482-M1990.

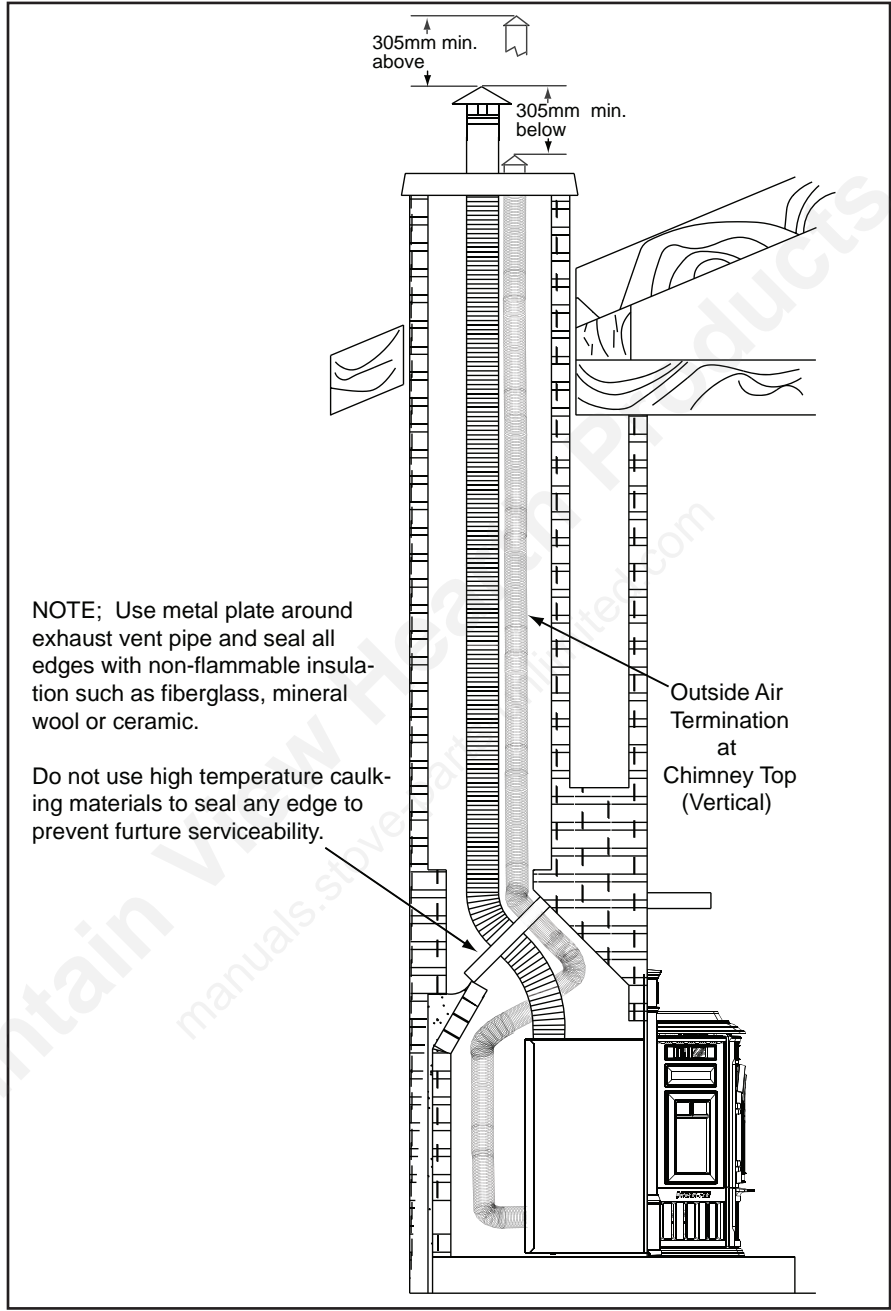


Figure 16.1

**NOTE:** In Canada this fireplace insert must be installed with a continous chimney liner a 6 inch (152mm) in diameter extending from the fireplace insert to the top of the chimney. The chimney liner must conform to the Class 3 requirments of CAN/ULC-S635, Standard for Lining Systems for Extising Masonry or Factory-Built Chimneys and Vents, or CAN/ULC-S640, Standard for Lining Systems for New Masonry Chimneys.

**CAUTION**

Check building codes prior to installation.

- Installation **MUST** comply with local, regional, state and national codes and regulations.
- Consult local building, fire officials or authorities having jurisdiction about restrictions, installation inspection, and permits.

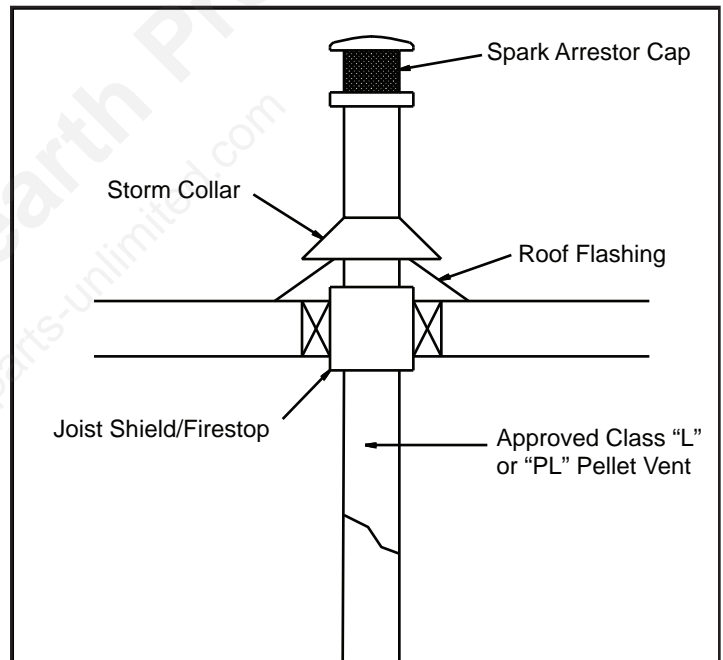
# 6 Mobile Home

## A. Mobile Home Installation

**You must use a Quadra-Fire Outside Air Kit for installation in a mobile home.**



1. An outside air inlet must be provided for the combustion air and must remain clear of leaves, debris, ice and/or snow. It must be unrestricted while the appliance is in use to prevent room air starvation which causes smoke spillage. Smoke spillage can also set off smoke alarms.
2. The combustion air duct system must be made of metal. It must permit zero clearance to combustible construction and prevent material from dropping into the inlet or into the area beneath the dwelling and contain a rodent screen.
3. The appliance must be secured to the mobile home structure by bolting it to the floor (using lag bolts). Use the same holes that secured the appliance to the shipping pallet.
4. The appliance must be grounded with #8 solid copper grounding wire or equivalent, terminated at each end with an NEC approved grounding device.
5. Refer to clearances to combustibles and floor protection requirements on **pages 9 & 10** for listings to combustibles and appropriate chimney systems.
6. Use silicone to create an effective vapor barrier at the location where the chimney or other component penetrates to the exterior of the structure.
7. Follow the chimney manufacturer's instructions when installing the vent system for use in a mobile home.
8. Installation shall be in accordance with the Manufacturers Home & Safety Standard (HUD) CFR 3280, Part 24.

<b>CAUTION</b>
THE STRUCTURAL INTEGRITY OF THE MOBILE HOME FLOOR, WALL AND CEILING/ROOF MUST BE MAINTAINED
Do NOT cut through:
<ul style="list-style-type: none"> <li>• Floor joist, wall, studs or ceiling trusses.</li> <li>• Any supporting material that would affect the structural integrity.</li> </ul>



**Figure 17.1**

 <b>WARNING</b>
Installation must comply with Manufactured Home and Safety Standard (HUD), CFR 3280, Part 24.

 <b>WARNING</b>
 <b>Asphyxiation Risk.</b> <b>NEVER INSTALL IN A SLEEPING ROOM.</b> Consumes oxygen in the room.

# 7 Appliance Set-Up

## A. Reversible Top or Rear Flue Adapter

### Top Vent Installation

1. Release ammo can latches on each side. **Figure 18.1.**
2. Place the reversible adapter in the correct position for your installation.
3. Make sure BOTH latches are in position before securing them.

### Rear Vent Installation

1. Remove the 90° adapter and installation screws from the packaging.
2. Attach the 90° adapter onto the vent adapter, using the 3 screws provided. You will need to pre-drill the holes for screw placement. Be sure to adjust the 90° adapter to the desired position for venting before drilling.
3. Silicone the pipe joints according to the Note below.

**NOTE:** All pipe must be sealed using welded seam pipe whenever possible. Seal pipe joints with high temperature silicone, minimum rate of 500°F (260°C).

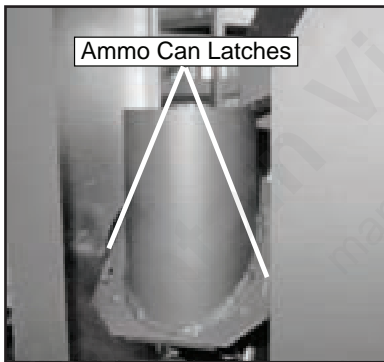


Figure 18.1 - Top Vent



Figure 18.2 - Rear Vent

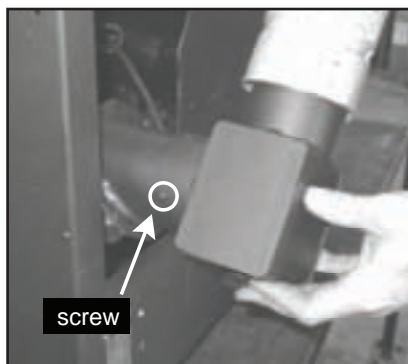


Figure 18.3 - Rear Vent

## B. Leveling System

The back legs are adjustable to allow for customized fit into zero clearance boxes.

1. Loosen 2 top screws and remove 2 bottom screws.
2. Adjust leg to desired height. Leg can slide up (shorter) or down (longer) to level the insert.
3. Tighten 2 top screws.
4. Drill 2 holes for the bottom 2 screws and re-install screws. **Figure 18.5.**

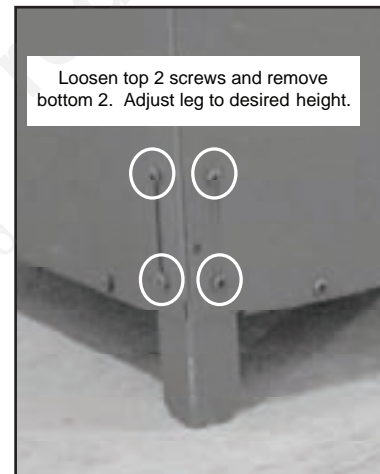


Figure 18.4

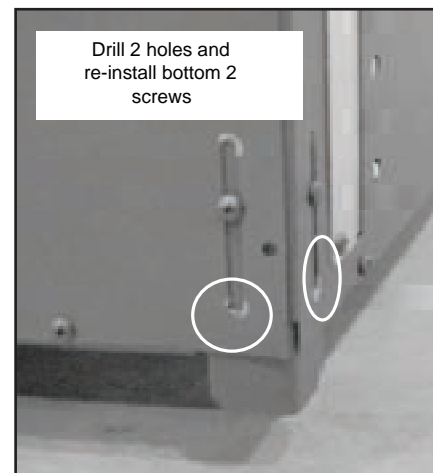


Figure 18.5

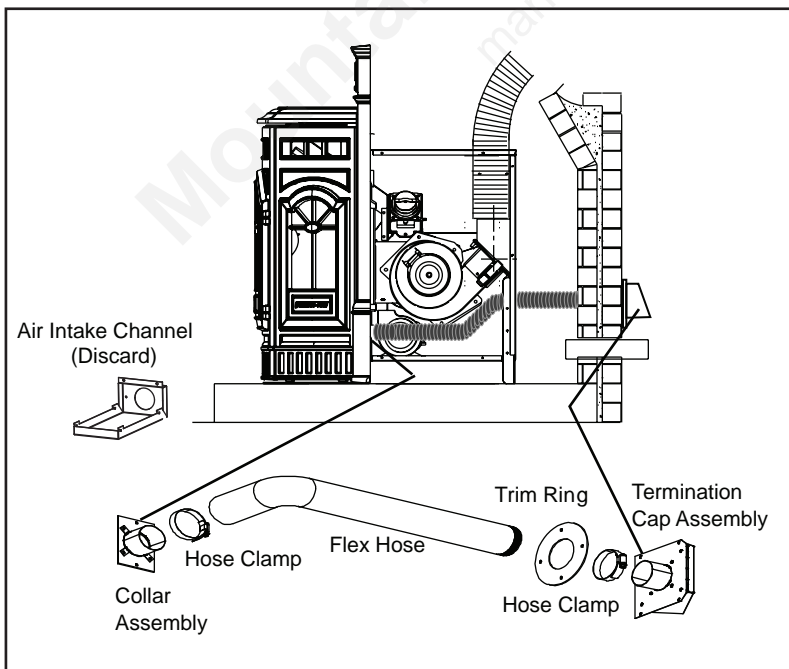
**C. Outside Air Kit Instructions**

**Parts Included in Kit:** 1 piece of 2 inch x 3 ft. flex hose, 2 hose clamps, 1 collar assembly, 1 termination cap assembly, 1 air intake channel, 1 trim ring, fasteners. **NOTE:** Discard air intake channel, it is not used on this appliance.

**Tools Needed:** Phillips head screwdriver; wire cutters; hole saw or jig saw.

1. Attach collar assembly to appliance. **Figure 19.1.** Measure distance from floor to air vent opening in appliance and mark location on wall.
3. Use saw to cut opening in wall. Cut a 2-1/2 to 3 inch (64-76mm) opening on inside wall and a 3 to 3-1/2 inch (76-89mm) opening on outside of house.
4. Use hose clamp to secure flex pipe to collar assembly.
5. Slide trim ring over flex pipe and run pipe through pre-cut hole in back of appliance and through the wall.
6. Attach hose to outside termination cap with second hose clamp.
7. Secure termination cap to outside surface.
8. Secure trim ring to interior wall.

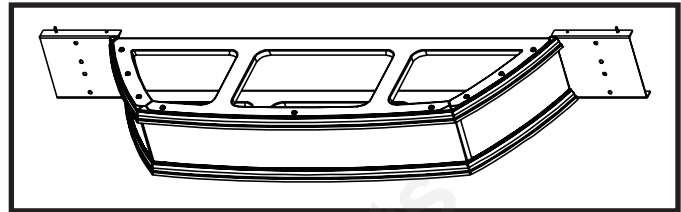
<b>CAUTION</b>
Never draw outside combustion air from: <ul style="list-style-type: none"> <li>Wall, floor or ceiling cavity</li> <li>Enclosed space such as an attic or garage</li> </ul>



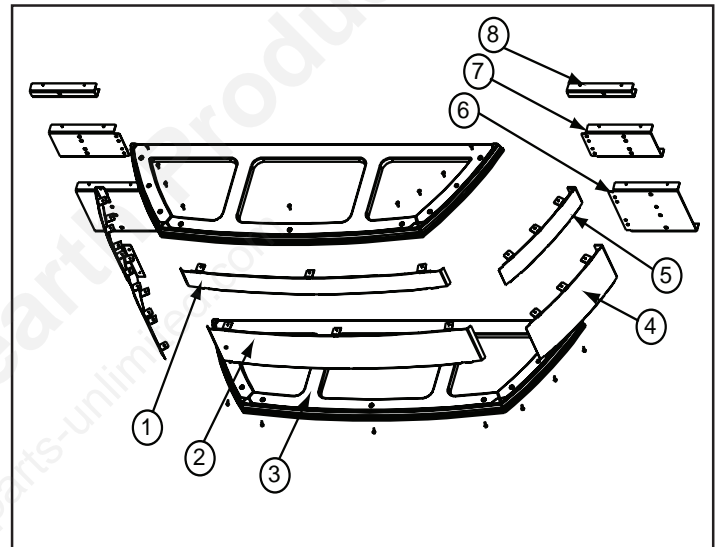
**Figure 19.1**

**D. Zero Clearance Trim Support Instructions**

**NOTE: Only for use on small size panels.**



**Figure 19.2 - Assembled View**

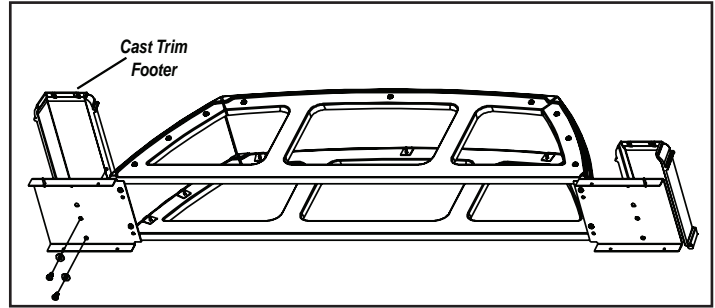


**Figure 19.3**

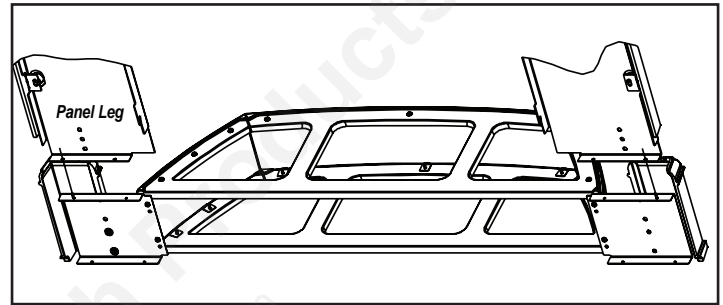
Item	Description
1	Front, 3 inch
2	Front, 5 inch
3	Cast Ring, Top & Bottom, Interchangeable
4	Side, 5 inch
5	Side, 3 inch
6	Panel Extension, 5 inch
7	Panel Extension, 3 inch
8	Panel Extension, Base Plate Only

**D. Zero Clearance Trim Support (Cont'd)**

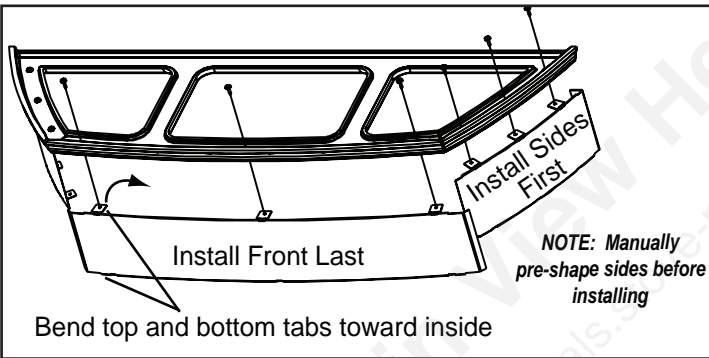
1. Remove contents from box and lay on protective surface to avoid scratching the paint.
2. Lay zero clearance front and sides face down. Bend the tab down toward the inside.
3. The side pieces are shipped flat. It is much easier to manually flex the sides into a bowed position before installing.
4. Lay 1 cast ring face up, which will become the bottom ring when installed. Attach the 2 sides FIRST and then the front piece. **Figure 20.1.**
5. Now turn the cast ring right side up and attach the top cast ring. **Figure 20.2.**
6. Attach the zero clearance panel extensions. **Figure 20.3**
7. Attach cast footers. **Figure 20.4.**
8. Place the assembled zero clearance trim support under the insert. **Figure 20.5.**



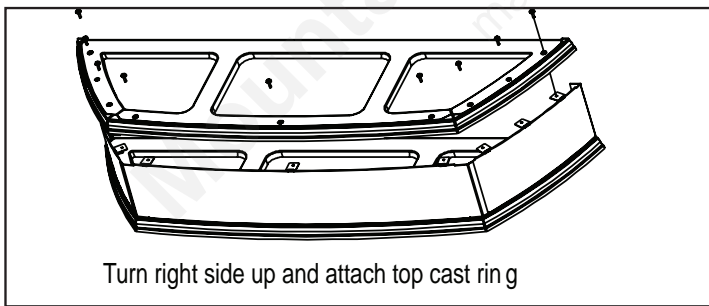
**Figure 20.4**



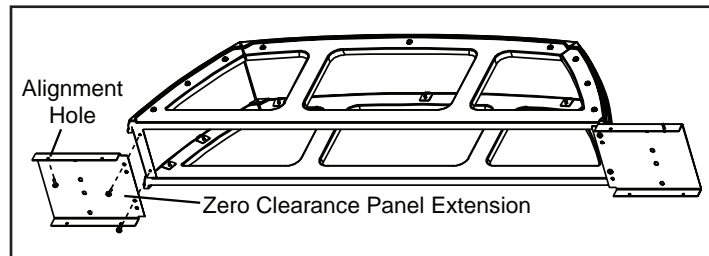
**Figure 20.5**



**Figure 20.1**



**Figure 20.2**



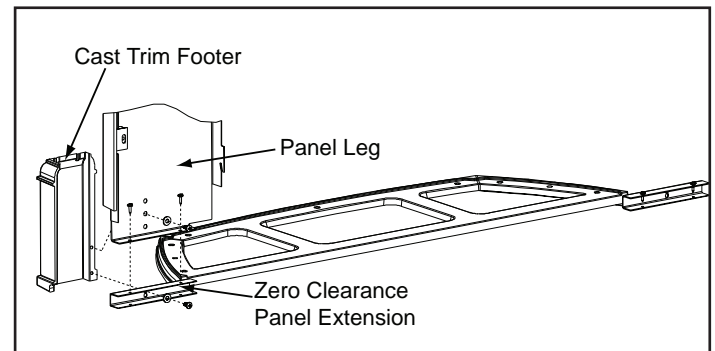
**Figure 20.3**

**Base Plate Only Installation**

**Parts Needed:** (1) cast ring (2) base zero clearance panel extensions. Discard balance of parts.

**Tools Needed:** Phillips head screwdriver

1. Attach base zero clearance panel extensions to cast ring.
2. Place assembly under appliance.



**Figure 20.6**

### E. Panel Set And Cast Trim Set

**Included in Panel Kit:** (2) side panels, left and right; (1) panel top; (1) fastener package.

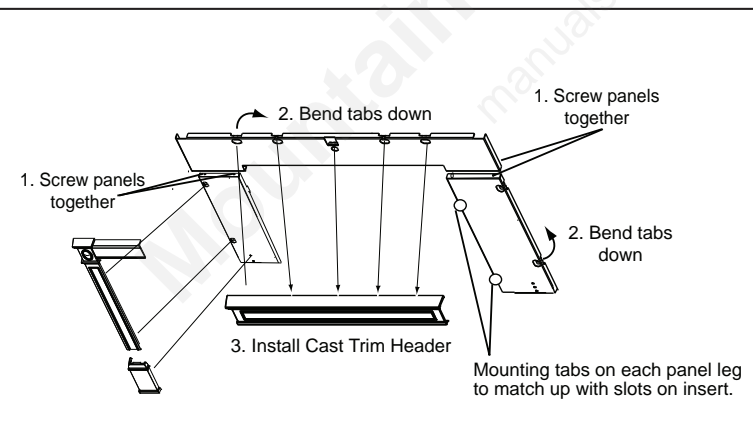
**Included in Cast Trim Kit:** (2) cast trim legs, left and right; (1) cast trim header; (2) cast trim footers, left and right; (1) fastener package.

**Tools Needed:** Powered Phillips head screw driver

1. Remove contents from box being careful not to scratch or damage the cast trim pieces.
2. Lay the panel set face down on protective covering to prevent scratching the painted surface.
3. Secure the panels legs to top panel with the screws provided.
4. Now bend the tabs down toward the backside of the panel set, 5 on top and 2 on each leg. Leave the panel set face down.
5. Place the corresponding cast trim pieces ( 2 cast trim legs and 1 cast trim header) underneath the panel set, also face down.
6. Place washer provided over tab and secure the trim and panel together with screw. Continue for all tabs.
7. Secure cast footers with screws.
8. Remove both left and right cast sides from insert, **See Figures 32.1, 32.2 and 32.3 on page 32.**
9. Slide panel and trim over the top of the insert into place matching the mounting tabs on the panel with the slots on the insert.

**CAUTION**

- Do NOT pick up assembled unit by corners.
- It is too heavy and may damage the panels.
- Pick up from center.



**Figure 21.1**



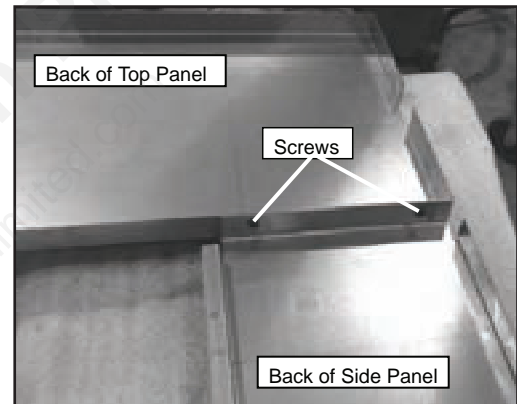
**Figure 21.2 - Completed View of Panel Set & Cast Trim Set**

### F. Panel & Trim Set, Econo

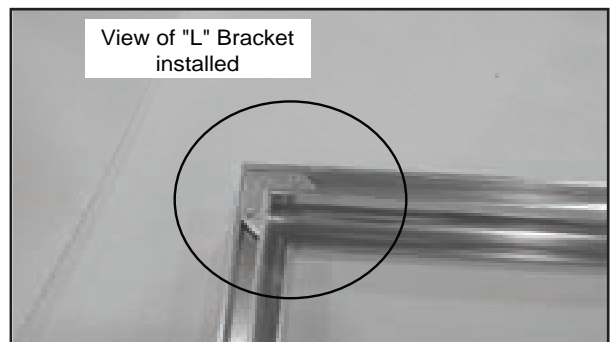
**Included in Panel & Trim Kit:** (2) corner brackets and set screws; (1) trim set, 3 piece; (2) side panels; (1) top panel; (4) screws;

**Tools Needed:** Powered Phillips head screw driver

1. Secure the top panel to the panel sides with the screws provided. **Figure 21.3.**
2. Assemble the gold trim with the (2) corner brackets provided. **Figure 21.4.**
3. Slide the assembled trim over the assembled panel set.
4. Slide panel and trim over the top of the insert into place matching the mounting tabs on the panel with the slots on the insert.



**Figure 21.3**



**Figure 21.4**

**G. Optional Log Set Placement Instructions**

**CAUTION**

Logs are FRAGILE. Use extreme care when handling or cleaning logs.

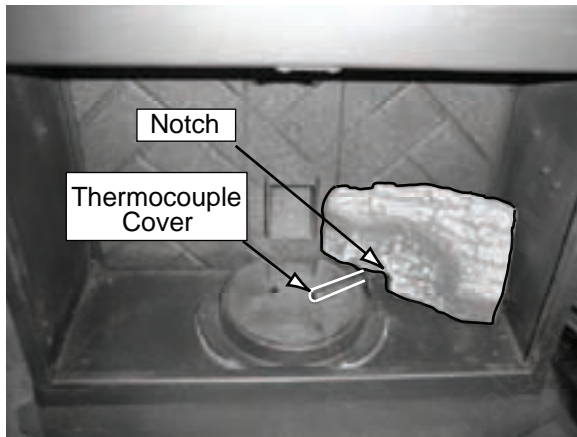
**Four Piece Log Set Installation**

1. Open the hinged cast face and open the glass door assembly.
2. Positioning the logs.

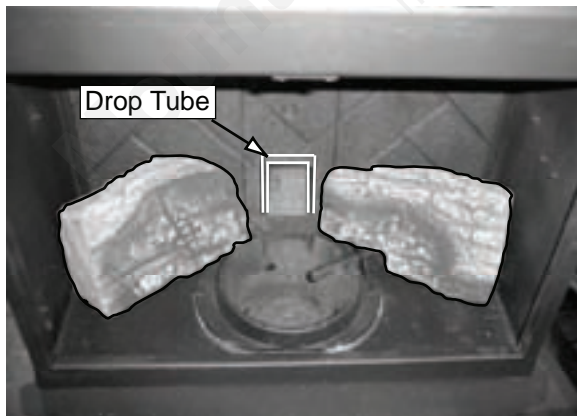
Place the right rear log as shown. There is a notch in the bottom of the log for clearance for the thermocouple and thermocouple cover (ceramic protection tube).

**Figure 22.1**

Continue placing the last 3 logs around the firepot as show in **Figures 22.2, 22.3 and 22.4**. Be careful not to block the drop tube in the back of the firebox where pellets feed into the firepot.



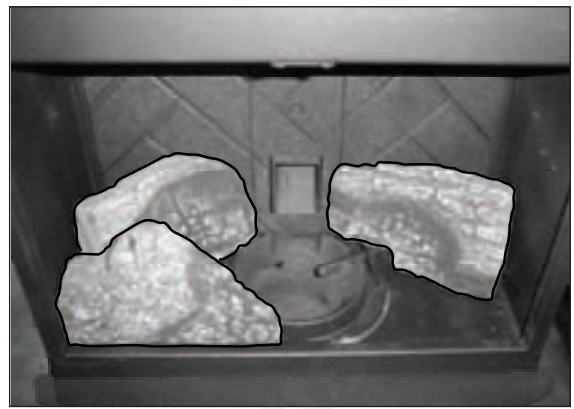
**Figure 22.1**



**Figure 22.2**

**NOTE:**

Due to the abrasive nature of a pellet appliance fire, the logs are not covered under warranty. Any placement variation other than shown here can cause excessive heat and shall void the appliance warranty.



**Figure 22.3**

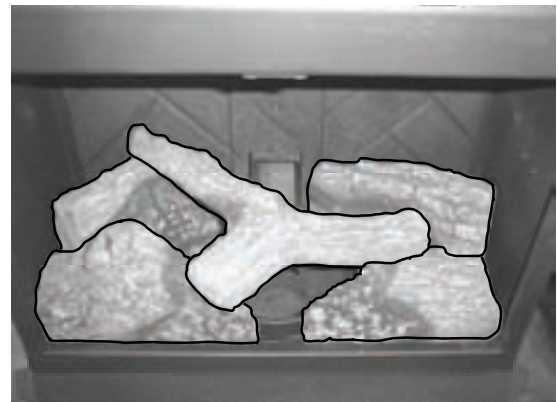


**Figure 22.4**

**Top Log Installation**

Place the log over the firepot. The charred area on the log is turned toward the back, not the front.

The log will be about 2-1/2 inches (64mm) above the firepot when in place. It must rest on the 3 logs in a stable position to prevent it from falling into the firepot. **Figure 22.5.**



**Figure 22.5**

**H. Thermostat Installation**

1. A 12 volt AC thermostat is required to operate this pellet appliance. You may use the included wall mount thermostat or purchase an optional programmable thermostat or remote control. The included thermostat is equipped with an adjustable heat anticipator. The current rating is .05 amps. The anticipator needs to be adjusted to the lowest setting available.
2. When mounting a thermostat on a wall, be sure to follow your thermostat installation instructions carefully.

**NOTE: Thermostat must be mounted level for accurate readings. The thermostat should be mounted on an inside wall and not in direct line with the appliance convection air. Remove any packaging from inside the thermostat before using.**

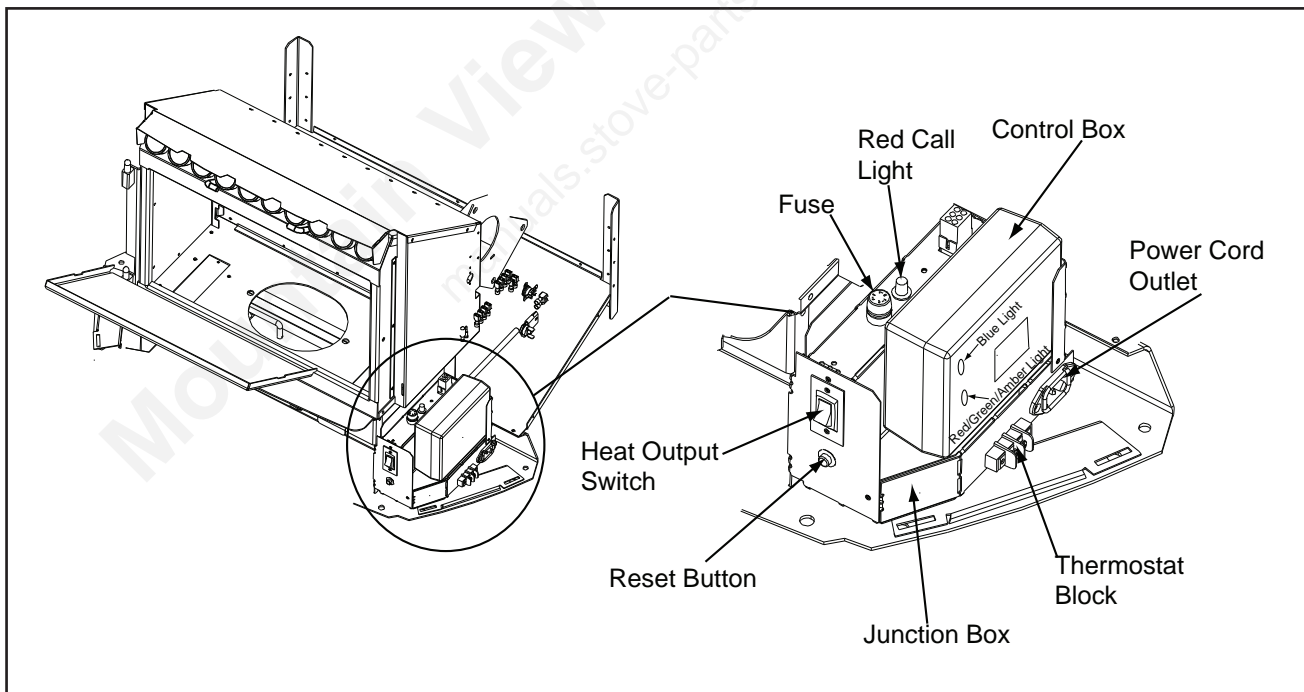
**NOTE: If the thermostat is located too close to the appliance, you may need to set the temperature setting slightly higher to maintain the desired temperature in your home.**

3. There is a 4 screw terminal block located on the junction box to the left of the power cord inlet. The center 2 screws are for the thermostat wires. The outer 2 are the mounting screws for the terminal block. **Figure 23.1.**

**CAUTION**

Shock hazard.

- Do NOT remove grounding prong from plug.
- Plug directly into properly grounded 3 prong receptacle.
- Route cord away from appliance.
- Do NOT route cord under or in front of appliance.



**Figure 23.1**

# 8 Operating Instructions

## A. Fuel Size, Material and Storage


### 1. Wood Pellets

Fuel pellets are made from sawdust or wood by-products. If the source material is hardwood, they can have a higher mineral content, creating more ash. Fuels containing bark will also have higher ash content. Minerals and other noncombustible materials such as sand will turn into a hard, glass-like substance called a clinker when heated to the extreme temperatures our firepot reaches. This is what forms clinkers in the bottom of the firepot. Trees from different areas will vary in mineral content. That is why some fuels produce more clinkers than others. Pellets are manufactured in either 1/4 inch or 5/16 inch (6-8mm) diameter and should be **no more than 1-1/2 inches (38mm) in length**. Pellet lengths may even vary by lot from the same manufacturer which is why the feed rate may need to be adjusted occasionally. **If you burn pellets longer than 1-1/2 inches (38mm) you may have an inconsistent fuel feed rate and/or missed ignitions.**

Pellet fuel quality can greatly fluctuate. We recommend using premium grade fuel with ash content less than 1%. Even in some fuel labeled "premium" ash content can vary from bag to bag and possibly exceed 1%. High ash fuel, or lack of maintenance, can cause the firepot to fill up and thus create a potential for smoking, sooting and possible hopper fires.

Always burn dry fuel. Burning fuel with high moisture content takes heat from the fuel and tends to cool the appliance, robbing heat from your home. Damp pellet fuel can clog the feed system.

We recommend that you buy fuel in multi-ton lots whenever possible. Buying large quantities of fuel at once will greatly reduce the number of times the feed adjustments will need to be made. However, we do recommend trying various brands before purchasing multi-ton lots to ensure your satisfaction.

	<b>WARNING</b>
	<p><b>Fire Risk.</b></p> <ul style="list-style-type: none"> <li>• High ash fuels, or lack of maintenance, can cause the firepot to overfill. Follow proper shutdown procedure if ash buildup exceeds half way point in firepot.</li> <li>• Failure to do so could result in smoking, sooting and possible hopper fires.</li> </ul>

### 2. Shelled Field Corn

Extensive factory and field testing has demonstrated shelled field corn to be an efficient and very economical fuel. We recommend the use of a 50-50 blend of corn and wood pellets. The only change in operation is that the feed rate may require a slight adjustment. The BTU output of the appliance varies slightly compared to pellets, depending on the quality of the

### 2. Shelled Field Corn (Cont'd)



corn used. In cases where it is acceptable for the appliance to run full time, 100% corn will work after the fire has been started using wood pellets.

When purchasing corn to burn in your appliance, read the ingredient label very carefully. **Do NOT purchase fuel that contains any additives** such as oils (i.e. soybean oil) and meals as it will result in poor unit performance. If you are buying corn the only ingredient that should be listed is corn.

Shelled field corn must be 15% or less moisture content. The corn must be clean and free from debris. Never burn corn straight from the field. Stalk parts, excessive fines and cob remnants, etc. will clog the auger mechanism. Corn with excessive grain dust must be screened by sifting with 3/16 (4.76mm) inch mesh screening.

Do not burn treated seed corn in your appliance. Seed corn is treated with chemical pesticides that are harmful or fatal if swallowed; therefore, seed corn is dangerous to have in the house, especially where children can reach it. Burning treated seed corn in your appliance will void your warranty and will destroy the exhaust system on the unit.

When changing to a different fuel, be sure to empty the hopper of the previous fuel and vacuum the hopper before you fill it with the new fuel.

	<b>WARNING</b>
	<p>Risk of Chemical Poisoning.</p> <ul style="list-style-type: none"> <li>• Do <u>Not</u> burn treated seed corn</li> <li>• Chemical pesticides are harmful or fatal if swallowed</li> <li>• Burning treated seed corn will void your warranty</li> </ul>

### 3. Storage

Wood pellets should be left in their original sealed bag until using. This will prevent moisture absorption.

Shelled corn should be stored in a tight container where it will not absorb moisture from damp or wet floors. This will also prevent rodents from becoming a problem.

Do not store any pellet fuel within the clearance requirements or in an area that would hinder routine cleaning and maintenance.

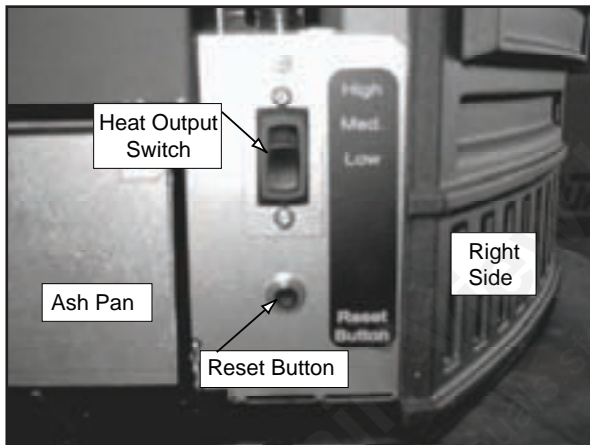
**B. General Operating Information**

**1. Thermostat Calls For Heat**

The appliance is like most modern furnaces; when the thermostat calls for heat, your appliance will automatically light and deliver heat. When the room is up to temperature and the thermostat is satisfied, the red call light will shut off and the appliance will shut down. The red call light is located behind the left access panel.

**2. Heat Output Controls**

This appliance is equipped with a heat output control switch that has three settings or burn rates; low, medium and high. The appliance will turn on and off as the thermostat demands. When the thermostat calls for heat, the appliance will always start up on High. After burning approximately 4 minutes, the appliance will then burn at the rate at which it was originally set. If the appliance is set at one of the lower settings, it will run quieter but takes longer to heat up an area than if it were set at a higher burn rate. Regardless of the burn rate, when the area is warm enough to satisfy the thermostat, the appliance will shut off.



**Figure 25.1**

**C. Before Your First Fire**

1. First, make sure your appliance has been properly installed and that all safety requirements have been met. Pay particular attention to the fire protection, venting and thermostat installation instructions.
2. Double check that the ash pan and firebox are empty!
3. Check the position of the thermocouple, located above the firepot, and make sure that it protrudes approximately 3/4 inch (19mm) into the firepot.
4. Close the front door.


<b>CAUTION</b>
<p>Tip of thermocouple must be in contact with the inside end of the thermocouple cover.</p> <p>Missed ignitions can occur.</p>

**D. Starting Your First Fire**

1. A thermostat is required for proper operation of this appliance, except for corn. At this time, fill the hopper with pellets, set the thermostat to its lowest setting. Plug the power cord into nearby outlet.
2. The exhaust blower will stay on for approximately 18 minutes even though the thermostat is not calling for heat. This is normal.
3. Locate the heat output control switch behind the right face on the lower right side of the firebox. Set to the HIGH setting and then adjust the thermostat to its highest setting. The red call light will be on which is located on the top of the junction box behind the right cast side. This indicates the thermostat is calling for heat. **Figure 25.1.**
4. The fuel feed system and the igniter should now be on.
5. For your first fire it will be necessary to press the reset button once a minute until pellets start to drop into the firepot, then press button 1 more time. This will fill the feed system and allow the appliance to begin dropping pellets. The appliance will continue to run as long as the thermostat is calling for heat.
6. Once the appliance has ignited, let it burn for approximately 15 minutes, then set the thermostat to the desired room temperature. Adjust the heat output control switch to the desired setting.

**E. Fire Characteristics**

A properly adjusted fire with the heat output control switch set on "HIGH" has a short active flame pattern that extends out of the firepot approximately 4 inches (102mm). If the fire has tall flames with black tails and seems somewhat lazy, the feed rate will need to be reduced. If the fire is not 4 inches (102mm) tall, increase the feed rate. A medium and low setting will give a shorter flame. The flame will rise and fall somewhat. This is normal.

 <p><b>WARNING</b></p>
<p><b>Fire Hazard.</b> Keep combustible materials, gasoline and other flammable vapors and liquids clear of appliance.</p> <ul style="list-style-type: none"> <li>• Do NOT store flammable materials in the appliance's vicinity.</li> <li>• DO NOT USE GASOLINE, LANTERN FUEL, KEROSENE, CHARCOAL LIGHTER FLUID OR SIMILAR LIQUIDS TO START OR "FRESHEN UP" A FIRE IN THIS HEATER.</li> <li>• DO NOT BURN GARBAGE OR FLAMMABLE FLUIDS SUCH AS GASOLINE, NAPHTHA OR ENGINE OIL.</li> <li>• DO NOT USE CHEMICALS OF FLUIDS TO START THE FIRE.</li> <li>• Keep all such liquids well away from the heater while it is in use.</li> <li>• Combustible materials may ignite.</li> </ul>

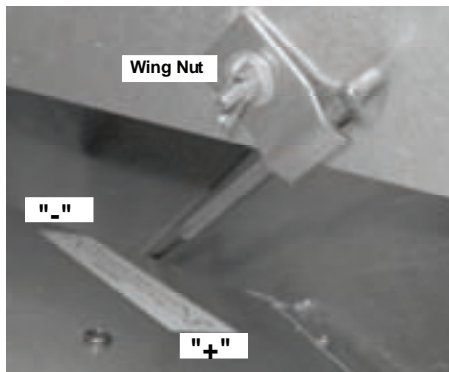
**F. Feed Rate Adjustment**

The fuel adjustment control rod is factory set, and should be adequate for most fuels.

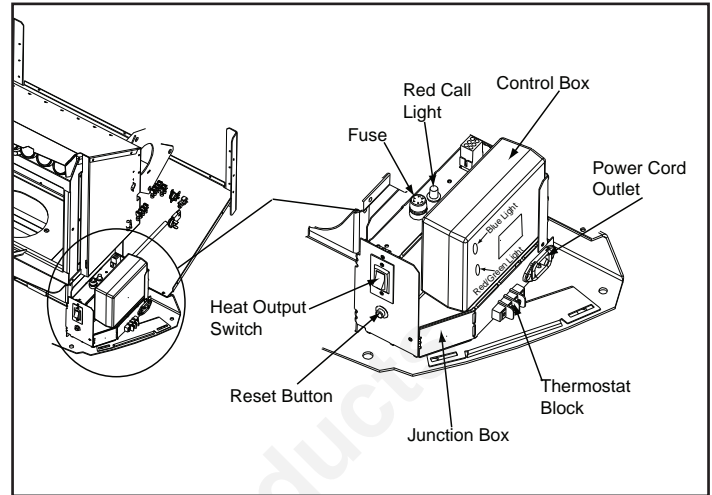
The set screw is located at the bottom of the hopper and set loose at the factory so the fuel adjustment control rod will slide by only loosening the wing nut. Do not re-tighten bottom set screw.

However, if the flame height is too high or too low, you will need to adjust the feed rate. Wait until the appliance has been burning for 15 minutes before making your adjustments and allow 15 minutes for feed adjustment to take effect. Make adjustments in approximately 1/2 inch increments.

1. Loosen the wing nut. **Figure 26.1.**
2. Adjust the fuel adjustment control rod towards the "+" symbol to increase the feed rate and flame height or towards the "-" symbol, to decrease the feed rate and flame height.
3. Re-tighten the wing nut.

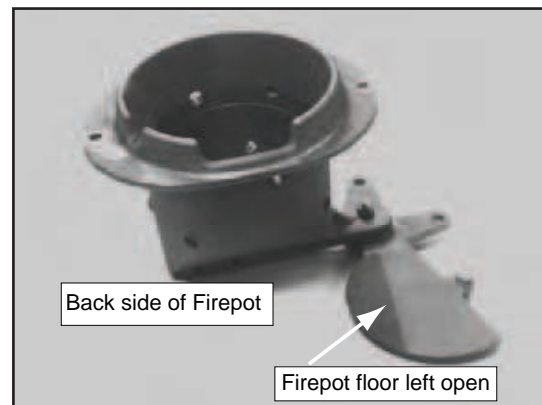


**Figure 26.1**



**Figure 26.1**

	<b>WARNING</b>
	<p><b>Fire Risk</b> Do NOT operate appliance:</p> <ul style="list-style-type: none"> <li>• With appliance door open.</li> <li>• Firepot floor open.</li> <li>• Cleaning slide plates open.</li> </ul> <p>Do NOT store fuel:</p> <ul style="list-style-type: none"> <li>• Closer than required clearances to combustibles to appliance</li> <li>• Within space required for loading or ash removal.</li> </ul>



**Figure 26.2 - DO NOT LEAVE FIREPOT FLOOR OPEN**

**G. Ignition Cycles**

1. During each ignition cycle, it is normal to see some smoke in the firebox. The smoke will stop once the fire starts.
2. The convection blower will automatically turn on after your appliance has reached the set temperature. This blower transfers heat from your appliance into the room, and will continue to run after the thermostat has stopped calling for heat until the appliance has cooled down.
3. Occasionally the appliance may run out of fuel and shut itself down. When this happens, the red call light will be on. To restart it, fill the hopper and press the reset button. **Figure 26.2.** When you press the reset button the red call light will go out. Release the button and the light will come back on. You should see a fire shortly. If not, follow the instructions on **page 25**, "Starting Your First Fire".

**H. Frequently Asked Questions**

ISSUES	SOLUTIONS
1. Metallic noise.	1. Noise is caused by metal expanding and contracting as it heats up and cools down, similar to the sound produced by a furnace or heating duct. This noise does not affect the operation or longevity of your appliance.
2. Ash buildup on glass.	2. This is normal. Clean the glass.
3. Glass has turned dirty.	3. Excessive build up of ash. The lower burn settings will produce more ash, the higher burn settings produce less. The more it burns on low the more frequent cleaning of the glass is required.
4. Fire has tall flames with black tails and is lazy.	4. The feed rate needs to be reduced or the firepot needs cleaning. Heat exchanger or exhaust blower needs cleaning.
5. Smokey start-up or puffs of smoke from the airwash.	5. Either the firepot is dirty or there is too much fuel at start-up and not enough air. Close down feed rate 1/4 (6mm) inch at a time until this no longer happens.
6. Large flame at start-up.	6. This is normal. Flame will settle down once the fire is established.

<b>CAUTION</b>
<p>Odors and vapors released during initial operation.</p> <ul style="list-style-type: none"> <li>• Curing of high temperature paint.</li> <li>• Open windows for air circulation.</li> </ul> <p>Odors may be irritating to sensitive individuals.</p>

# 9 Troubleshooting

With proper installation, operation, and maintenance your appliance will provide years of trouble-free service. If you do experience a problem, this troubleshooting guide will assist a qualified service person in the diagnosis of a problem and the corrective action to be taken. ***This troubleshooting guide can only be used by a qualified service technician.***

Symptom	Possible Cause	Corrective Action
Plug in appliance - No response.	No current to outlet. .7 amp fuse defective. #3 snap disc tripped or defective. Control box defective.	Check circuit breaker at service panel. Replace fuse. Reset or replace snap disc. Replace control box.
Call light on. No fire. No fuel in firepot.	Out of fuel. #2 snap disc may be defective. Vacuum switch not closing, no vacuum.  Control box defective.	Check hopper. Fill with fuel. Replace snap disc. Check exhaust blower is plugged in and operating. Check vacuum switch is plugged in. Check vacuum hose is in good condition, clear and connected at both ends. Check thermocouple is in good condition and plugged in properly. Make sure venting system is clean. Make sure front door is closed.  Replace control box.
Call light on. No fire. Partially burned fuel in firepot.	Firepot clean-out plate not closed.  Firepot is dirty (missed ignition).	Check that firepot clean-out plate is fully closed.  Clean firepot. Make sure there is no clinker in the firepot.  Clinkers may have to be broken up with firepot scraper tool or other means.
Call light on. No fire. Unburned pellets in firepot.	Firepot clean-out plate not closed.  Firepot is dirty.  Ignition hole blocked.  Igniter not working.  Control box defective.	Check that firepot clean-out plate is fully closed.  Clean firepot. Make sure there is not a clinker in the firepot. Clinkers may have to be pushed out of firepot with firepot scraper tool or other means.  Scrape with solid piece of wire.  Remove ash drawer to see if igniter is glowing red on start-up. Check igniter wires for good connection. Replace igniter using 1/4 inch (6mm) male /female spade connectors.  Replace control box.
Slow or smoky start-up.	Firepot clean-out plate not closed.  Firepot is dirty.  Excessive amount of fuel at start-up.	Check that firepot clean-out is fully closed.  Clean firepot. Make sure there is not a clinker in the firepot. Clinkers may have to be pushed out of firepot with firepot scraper tool or other means.  Reduce feed rate using feed rate adjustment control rod located inside hopper.

Symptom	Possible Cause	Corrective Action
Slow or smoky start-up (Cont'd)	Dirty exhaust and/or venting system.	Check for ash build up in appliance, including behind rear panels, firebox, heat exchanger, exhaust blower and venting.
Feed system fails to start.	<p>Out of fuel. #2 snap disc may be defective.</p> <p>Vacuum switch not closing. No vacuum.</p> <p>Feed system jammed or blocked.</p> <p>Feed spring not turning with feed motor.</p> <p>Feed motor defective or not plugged in.</p>	<p>Check hopper, fill with fuel.</p> <p>Replace snap disc. Firebox door must be closed securely.</p> <p>Check exhaust blower is plugged in and operating. Check vacuum switch is plugged in. Check vacuum hose is in good condition, clear and connected at both ends. Check thermocouple is in good condition and plugged in properly. Make sure venting system is clean. <b>NOTE:</b> High winds blowing into the venting system can pressurize the firebox causing loss of vacuum.</p> <p>Empty hopper of fuel. Use a wet/dry vacuum cleaner to remove remaining fuel, from hopper, including feed tube. Check feed chute for obstructions. Loosen 2 screws and jiggle feed assembly.</p> <p>Check that set screw is tight on feed spring shaft at end of feed motor.</p> <p>Check connections on feed motor, replace if defective.</p>
No call light. Appliance does not begin start sequence.	<p>Thermostat not set to a high enough temperature.</p> <p>Snap Disc #3 tripped.</p> <p>No power.</p> <p>Fuse blown.</p> <p>Connections at thermostat and/or appliance not making proper contact.</p> <p>Defective thermostat or thermostat wiring.</p> <p>Control box defective.</p>	<p>Adjust thermostat above room temperature.</p> <p>Reset snap disc.</p> <p>Connect to power.</p> <p>Replace fuse.</p> <p>Check connections at thermostat and appliance.</p> <p>Replace thermostat or wiring. <b>NOTE:</b> To test thermostat and wiring, use a jumper wire at the thermostat block on the appliance to by-pass thermostat and wiring.</p> <p>Replace control box.</p>
Appliance fails to shut off.	Call light on.	<p>Turn thermostat off.</p> <p>If call light does not go out, disconnect thermostat wires from appliance. If call light does go out, thermostat or wires are defective.</p>

Symptom	Possible Cause	Corrective Action
Convection blower fails to start.	No call light. #1 snap disc defective. Blower not plugged in. Blower is defective. Control box is defective.	Defective control box. Replace snap disc. Check that blower is plugged into wire harness. Replace blower. Replace control box.
Exhaust blower fails to start or does not shut off.	Blower not plugged in. Blower is clogged with ash. Blower is defective. Control box is defective.	Check that blower is plugged into wire harness. Clean exhaust system. Replace blower. Replace control box.
Large, lazy flame, orange color. Black ash on glass.	Dirty appliance. Poor fuel quality, high ash content.  Firepot clean-out plate not completely closed.  Excessive amount of fuel.	Clean appliance, including firepot, heat exchangers and venting system. Remove stainless steel baffle from firebox to clean ash from on top of baffle. Clean behind rear brick panels. Change fuel brand to premium.  Check that firepot clean-out plate is fully closed.  Reduce feed rate using feed rate adjustment control rod located inside hopper.
Nuisance shutdowns.	Low flame. Sawdust buildup in hopper. Feed motor is reversing. Defective thermocouple. Defective control box Firepot more than 1/2 full	Increase feed by opening feed rate adjustment control rod located inside hopper.  Clean hopper, see <b>page 31</b> .  Check for good connections between feed motor and wire harness.  Replace thermocouple.  Replace control box.  See <b>page 31</b> for detailed instructions for "High Ash Fuel Content Maintenance"
Appliance calls for heat. Call light illuminates. Exhaust blower starts. No feed or igniter.	Thermocouple is defective or not properly plugged in.  Defective control box	Check connections on thermocouple or replace if defective. A flashing yellow light on the control box indicates a problem with the thermocouple.  Replace control box.

# 10 Maintaining & Servicing Your Appliance

## A. Proper Shutdown Procedure

**CAUTION**

**Shock and Smoke Hazard**

- Turn down thermostat, let appliance completely cool and exhaust blower must be off. Now you can unplug appliance before servicing.
- Smoke spillage into room can occur if appliance is not cool before unplugging.
- Risk of shock if appliance not unplugged before servicing appliance.

**Follow the detailed instructions found in this section for each step listed as referenced in the chart below.**

## B. Quick Reference Maintenance Chart

Cleaning or Inspection	Frequency		Daily	Weekly	Monthly	Yearly
Ash Pan	Every 5 bags of fuel	OR		X		
Ash Removal from Firebox	More frequently depending on the fuel type or ash build-up	OR		X		
Beneath Heat Exchanger	Every 1 ton of fuel	OR			X	
Blower, Combustion (Exhaust)	More frequently depending on the fuel type	OR				X
Blower, Convection	More frequently depending on the fuel type	OR				X
Door Latch Inspection	Prior to heating season	OR			X	
Exhaust Path	More frequently depending on ash build-up	OR				X
Firebox - Prepare for Non-Burn Season	At end of heating season	OR				X
Firepot - Burning pellets - hardwood	Every 3 bags	OR	X			
Firepot - Burning pellets - softwood	Every 5 bags	OR	X			
Firepot - Burning Corn	Every 1 bag	OR	X			
Glass	When clear view of firepot becomes obscure	OR		X		
Heat Exchanger & Drop Tube	Every 1 ton of fuel	OR			X	
Hopper	Every 1 ton of fuel or when changing fuel types	OR			X	
Top Vent Adapter	More frequently depending on the fuel type or ash build-up	OR				X
Venting System	More frequently depending on the fuel type	OR				X

## C. General Maintenance & Cleaning

### 1. Types of Fuel

Depending on the type of fuel you are burning will dictate how often you have to clean your firepot.

If the fuel you are burning has a high dirt or ash content or you are burning shelled field corn, it may be necessary to clean the firepot more than once a day.

Dirty fuel will cause clinkers to form in the firepot. A clinker is formed when dirt, ash or a non-burnable substance is heated to 2000°F (1093°C) and becomes glass-like. See **“D” page 35** in this section for more details on fuels with high ash content.

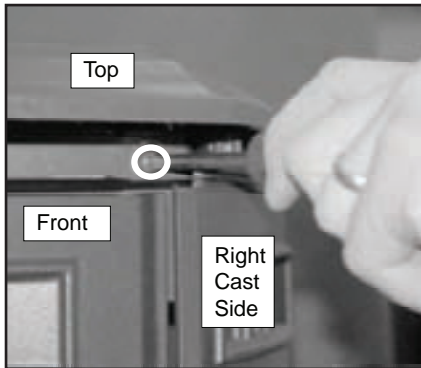


**Figure 31.1 - Clinker**

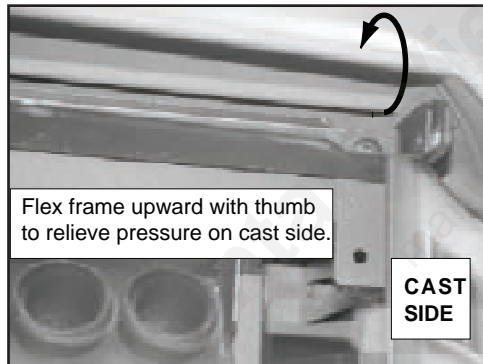
**NOTICE:** These are recommendations. Clean more frequently if you encounter heavy build-up of ash at the recommended interval or you see soot coming from the vent. **Not properly cleaning your appliance on a regular basis will void your warranty.**

**2. Remove Cast Sides for Cleaning & Maintenance**

- a. Loosen screw on top right corner directly under the cast top, but do not remove. **Figure 32.1.**
- b. With thumb, press upward on the frame to relieve the pressure on the cast side. **Figure 32.2.**
- c. Slide the cast side downward as shown in **Figure 32.3.** (The top has been removed to show the details.)
- d. Lay sides on protective padding to avoid scratching the paint or chipping the porcelain.
- e. Repeat for the other side.



**Figure 32.1**



**Figure 32.2**



**Figure 32.3**

**3. Cleaning Firepot with Cleaning Rod & Firepot Scraper**

- **Frequency:** Daily or more often as needed
- **By:** Homeowner
- a. The appliance must be in complete shutdown and cool and the exhaust blower off. If you are just cleaning the firepot, there is no need to unplug the appliance.
- b. Pull firepot cleaning rod OUT a couple of times to help shake debris loose. **See Figure 33.1 on page 33.** If rod is hard to pull, it may be necessary to use your firepot clean-out tool to chip away material that has built up on the bottom plate of the firepot and to push out any clinkers. Larger clinkers may have to be removed from the top of the firepot. Corn clinkers can be especially difficult to break up.
- c. The firepot floor plate must be fully closed when finished. **See Figure 26.2 on page 26.**

	<b>WARNING</b>
Fire Risk	
<ul style="list-style-type: none"> <li>• NEVER pull firepot cleaning rod or cleaning slide plates out when appliance is operating.</li> <li>• The cleaning slide plates must be fully CLOSED when appliance is operating.</li> <li>• Hot pellets may fall into ashpan and start a fire or mis-starts due to lack of vacuum.</li> </ul>	

**4. Ash Removal from Firebox**

- **Frequency:** Weekly or more frequently depending on ash build-up.
- **By:** Homeowner
- a. There must not be any hot ashes in the firebox during cleaning so allow the appliance to completely cool. The firebox ash should be removed every time the firepot is cleaned. Frequent cleaning of the ash in the firebox will help slow down the build-up of ash in the exhaust blower and vent system.
- b. Plug in your appliance, if unplugged, and turn the thermostat on and immediately shut it off to start the exhaust blower on its cycle time. It will pull fly ash out the exhaust instead of into the room.
- c. Open cast hinged face. Directly underneath the firebox door and to the left and right of the firepot are 2 cleaning slide plates with finger holes. Pull both slide plates out and then open the glass door. Sweep the remaining ash from the firebox into the 2 open holes. A paint brush works well for this. Close slide plates.
- d. This ash is deposited in the same ash pan as the firepot debris. The ash pan should be emptied every time you clean the firebox. Remember to place the ash and debris into a metal or noncombustible container.

**4. Ash Removal from Firebox (Cont'd)**

e. The 2 cleaning slide plates must be fully closed when cleaning is complete. **See Disposal of Ashes.**




**5. Cleaning Ash Pan**

- **Frequency:** Weekly or every 5 bags of fuel
- **By:** Homeowner

Locate the ash pan underneath the firepot. Open the bottom ash door and slide the ash pan straight out. Empty into a non-combustible container and re-install ash pan. **See Disposal of Ashes.**



**6. Cleaning Heat Exchanger Chambers & Drop Tube**

- **Frequency:** Monthly or every 1 ton of fuel
- **By:** Homeowner

	<b>WARNING</b>
	Heat exchanger cleaning rods may be warm to the touch. For safety purposes wear gloves.
	Do not pull heat exchanger cleaning rods while appliance is operating. Push cleaning rods IN when done, DO NOT leave cleaning rods OUT. Injury can occur.

The amount of ash buildup in the firepot will be a good guide to determine how often you should clean the heat exchangers.

- Allow the appliance to completely cool down before pulling the cleaning rods. Turn the thermostat on and then immediately off to start the exhaust blower on its cycle time. It will pull fly ash out the exhaust instead of into the room. Open the cast front door to access the 2 cleaning rods. **Figure 33.1.**
- Locate the 2 rods directly underneath the heat exchanger tubes. Rods are bent at a 90° angle for easy handling.
- To clean, pull the rods straight out until it stops, approximately 10 inches (254mm). Slide the rods OUT and IN a couple of times.

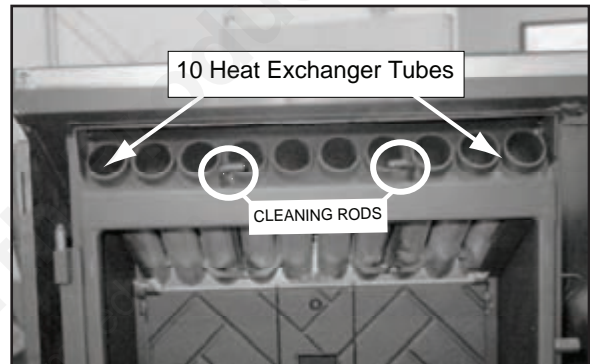
	<b>WARNING</b>
	Disposal of Ashes <ul style="list-style-type: none"> <li>• Ashes should be placed in metal container with tight fitting lid.</li> <li>• Ashes should be retained in closed container until all cinders have thoroughly cooled.</li> </ul>

**7. Disposal of Ashes**

- **Frequency:** As needed
- **By:** Homeowner

Ashes should be placed in a metal container with a tight-fitting lid. The closed container of ashes should be placed on a non-combustible floor or on the ground, well away from all combustible materials, pending final disposal.

If the ashes are disposed of by burial in soil or otherwise locally dispersed, they should be retained in the closed container until all cinders have been thoroughly cooled.



**Figure 33.1**

**8. Cleaning Beneath Heat Exchanger**

- **Frequency:** Monthly or after burning 1 ton of fuel
- **By:** Homeowner

- Be sure the appliance is allowed to cool, has been unplugged and the exhaust blower is off
- A more thorough cleaning is needed to remove the excess ash that is left behind from the use of the cleaning rods for the heat exchanger tubes.
- The ash will be resting on the back of the baffle. This will require removing the cast baffle. Please refer to **page 33** for a detailed explanation of removing the baffle.

**NOTE: There are heavy duty vacuum cleaners specifically designed for solid fuel appliance cleaning.**

**9. Cleaning the Exhaust Path**

- **Frequency:** Yearly or more frequently depending on ash build-up.
- **By:** Homeowner
  - Appliance must be completely cool.
  - Open cast front door. Remove right brick and thoroughly vacuum the area and continue throughout the rest of the firebox. **See Figure 37.3 on page 37.**
  - Replace right brick and close cast front door.

**10. Cleaning the Hopper**

- **Frequency:** Monthly or after burning 1 ton of fuel
- **By:** Homeowner

After burning approximately 1 ton of fuel you will need to clean the hopper to prevent sawdust build-up.

A combination of sawdust and pellets on the auger reduces the amount of fuel supply to the firepot. This can result in nuisance shutdowns and mis-starts.

- a. The appliance must be in complete shutdown. Allow the appliance to completely cool down.
- b. Empty the hopper of any remaining pellets.
- c. Vacuum the hopper and feed tube.

**11. Soot and Fly Ash: Formation & Need for Removal in Exhaust Venting System.**

- **Frequency:** Yearly or more frequently depending on ash build-up.
- **By:** Qualified Service Technician/Homeowner

Be sure the appliance is allowed to cool, has been unplugged and the exhaust blower is off.

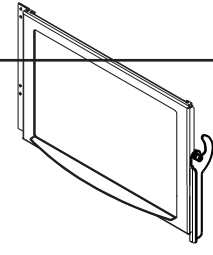
The products of combustion will contain small particles of fly ash. The fly ash will collect in the exhaust venting system and restrict the flow of the flue gases.

At start-up if there is incomplete combustion, or if there is a shutdown or incorrect operation of the appliance it will lead to some soot formation. This will collect in the exhaust venting system.

The venting system may need to be cleaned at least once a year or more often depending upon the quality of your fuel or if there is a lot of horizontal pipe sections. Ash will build up more quickly in the horizontal sections.

**12. Cleaning the Glass**

- **Frequency:** When clear view of the firepot becomes obscure
- **By:** Homeowner
  - a. Appliance must be completely cool before cleaning glass.
  - b. Use a damp paper towel or any non-abrasive glass cleaner. Wipe off with dry towel.



**CAUTION**

Handle glass assembly with care.

**When cleaning glass:**

- Avoid striking, scratching or slamming glass.
- Do NOT clean glass when hot.

- Do NOT use abrasive cleaners.
- Use a hard water deposit glass cleaner on white film.
- Refer to maintenance instructions.

**13. Cleaning Convection Blower - Requires No Lubrication**

- **Frequency:** Yearly or as needed
- **By:** Qualified Service Technician
  - a. The appliance must be in complete shutdown and completely cooled.
  - b. Remove both the left and right cast sides.
  - c. Use either a can of compressed air or an air compressor.
  - d. Reach as far back as possible and spray compressed air liberally from both sides at the blower. This will remove any lint or dust build-up on the impellers.

**14. Cleaning Exhaust Blower - Requires No Lubrication**

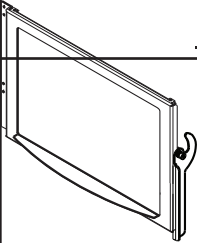
- **Frequency:** Yearly or as needed
- **By:** Qualified Service Technician
- **Task:** Contact your local dealer.


**15. Door Latch Inspection**

- **Frequency:** Prior to heating season
- **By:** Homeowner

The door latch is non-adjustable but the gasketing between the glass and firebox should be inspected periodically to make sure there is a good seal.

NOTE: There is no gasket on the bottom of glass.



 **WARNING**

Handle glass with care.

- Inspect the gasket to ensure it is undamaged.
- Do NOT strike, slam or scratch glass.
- Do NOT operate appliance with glass assembly removed.

- Do NOT operate with glass cracked, broken or scratched.

**16. Door Gasket Inspection**

- **Frequency:** Monthly or after burning 1 ton of fuel
- **By:** Homeowner

To inspect the door rope (gasket), open the door and see that the door rope extends approximately 1/8 to 3/16 inch (3 to 9.5mm) from the door rope channel.

It should show signs of compaction all the way around the door where the rope contacts the face of the insert.

**17. Preparing Firebox for Non-Burn Season**

- **Frequency:** Yearly
- **By:** Homeowner
  - a. Be sure the appliance is allowed to cool, has been unplugged and the exhaust blower is off.
  - b. Remove all ash from the firebox and vacuum thoroughly.
  - c. Paint all exposed steel, including cast-iron.
    - Use the Touch-Up paint supplied with the appliance; or;
    - Purchase paint from your local dealer.
    - Must use a high-temperature paint made specifically for heating appliances.

**D. High Ash Fuel Content Maintenance**

- **Frequency:** When the ash build-up exceeds more than half way up the firepot.
- **By:** Homeowner

Poor quality pellet fuel, or lack of maintenance, can create conditions that make the firepot fill quickly with ashes and clinkers.

This condition makes the appliance susceptible to overfilling the firepot with pellets which may result in smoking, sooting and possible hopper fires. **Figure 35.1** shows an example where the firepot overfills, pellets back up into the feed tube and ash has accumulated in the firebox.

An inefficient and non-economical method of burning of fuel caused by poor quality pellet fuel is shown in **Figure 35.2**.

The correct flame size when good quality, premium pellet fuel is burned is shown in **Figure 35.3**.

If the ash buildup exceeds the half way point in the firepot **IMMEDIATE ATTENTION AND CLEANING IS REQUIRED.**

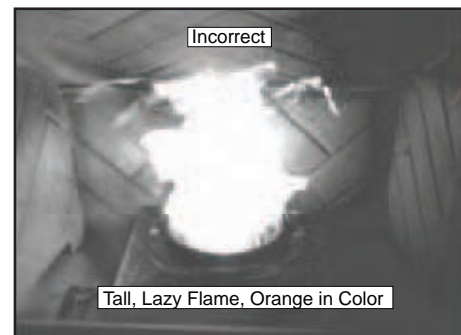
**WARNING**

**Fire and Smoke Risk.**

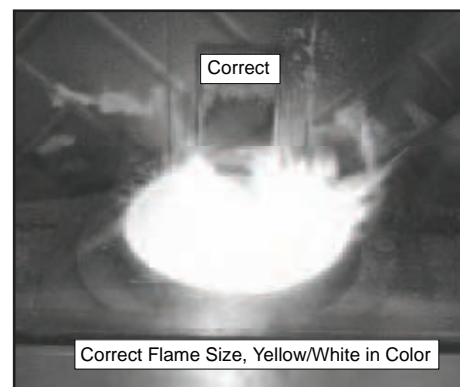
- High ash fuels or lack of maintenance can cause firepot to overfill. Follow proper shutdown procedure if ash buildup exceeds half way point in firepot.
- Failure to do so could result in smoking, sooting and possible hopper fires.



**Figure 35.1**

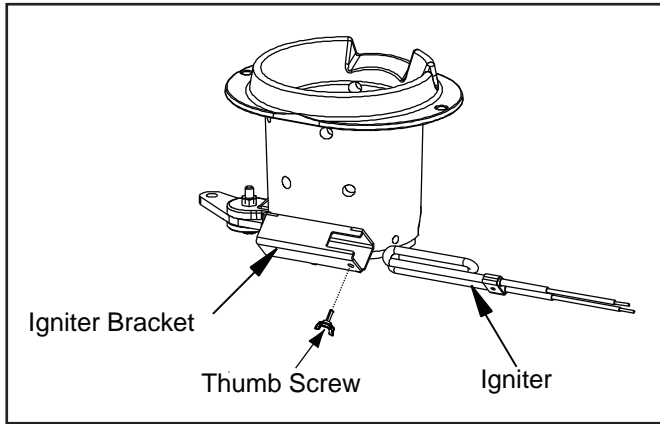


**Figure 35.2**



**Figure 35.3**

### E. Igniter Replacement



**Figure 36.1**

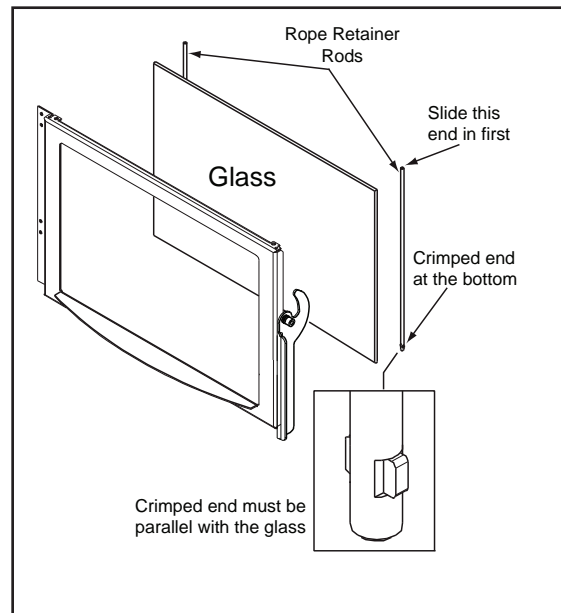
- a. Shut down the appliance by turning down the thermostat and let the appliance completely cool down. After the appliance has cooled down, unplug it and remove the ash pan.
- b. The wire leads to the igniter are connected to the wire harness with 1/4 inch (6mm) male / female spade connectors. These wires will pull forward approximately 4 to 5 inches (102 to 127mm). Disconnect the spade connections and remove the igniter from the chamber. Loosen the thumb screw and slide igniter out.
- c. Install new igniter into the chamber and tighten the thumb screw. Re-connect the wires to the 2 leads with the spade connectors.
- d. Remove the right cast side and pull the wire leads back toward the rear of the appliance to take-up the 4 to 5 inches (102mm to 107mm) previously pulled out. This will keep the wires out of the way of the ash pan. Double check that the igniter wires are clear of any movement, i.e. ash pan, firepot cleaning rod, cleaning slide plates, etc.
- f. Re-install the ash pan and then re-install the cast side panel and re-connect the power.

### F. Glass Replacement

**⚠ WARNING**

- Glass is 5mm thick high temperature heat-resistant ceramic glass.
- DO NOT REPLACE with any other material.
- Alternate material may shatter and cause injury

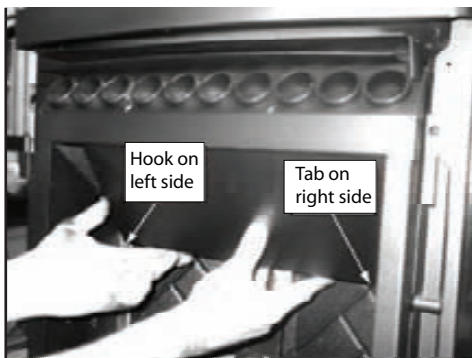
- a. Open hinged cast face and lift door assembly off from the insert and lay on a flat surface face down.
- b. Using a screwdriver, tap the bottom of the rope retainer rod to push it up out of the hole. The top end of the rod will slide up. Swing the rod toward you from the bottom and remove the rod. Repeat for other side.
- c. Remove old glass and replace with new glass.
- d. Slide the retainer rod into the top hole first, and then line up the bottom crimped end with the hole in the door. The crimped end must be parallel with the glass in order to insert it into place. **Figure 36.2.**



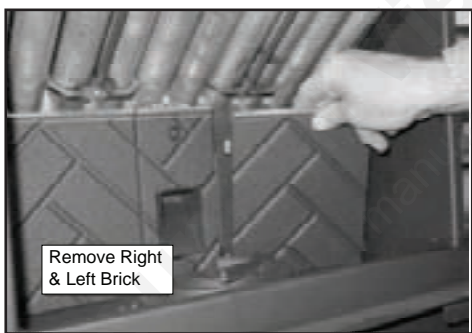
**Figure 36.2**

**G. Baffle & Brick Set Removal**

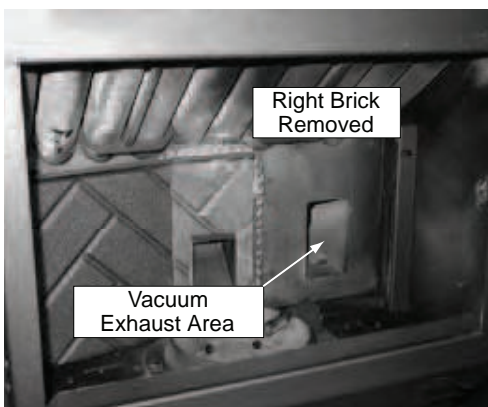
1. Follow proper shutdown procedures on **Page 31**.  
The top baffle has a hook on the bottom left side that rests on the top lip of the cast brick. There is a tab on the bottom right side that hooks into the side bracket. Remove the top baffle by first pulling the baffle forward until back edge drops down. Then slide baffle back until the front edge clears the shelf that it had been resting on. **Figure 37.1**.
3. The top baffle must be removed before you can remove the right and left brick. Remove the right brick by holding top lip of brick and lifting up, then push outside edge back. Slide brick to the right until it is flush with the firebox. Rotate the inside edge of the brick forward and remove brick. Repeat for left brick. **Figure 37.2**.



**Figure 37.1**



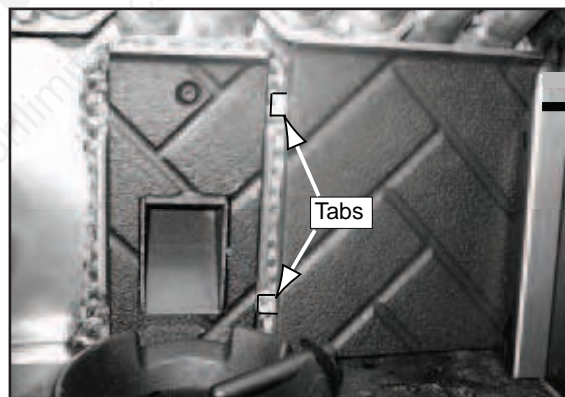
**Figure 37.2**



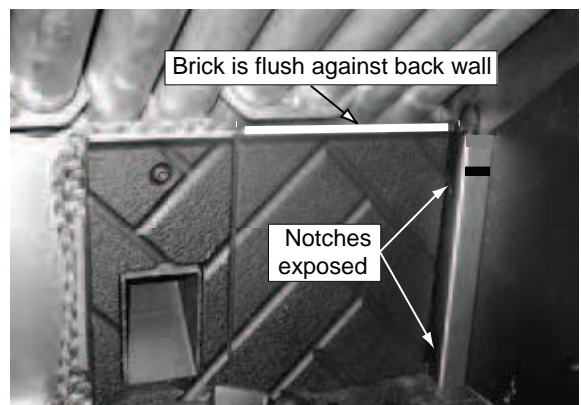
**Figure 37.3**

**Re-installing Baffle & Brick Set**

1. Place right brick in behind the right bracket, and then slide to the left so the tabs are behind the center brick. **Figure 37.4**
2. The brick will be flush against the back wall and notches exposed in the side bracket. **Figure 37.5**.
3. Lift slightly and pull the right edge of the brick forward until it stops and then drops down into both top and bottom notches of right bracket and locks into place. **Figures 37.1 and 37.2**.
4. Repeat for left brick.
5. Insert baffle into top front inside the firebox and pull forward. Then raise up the bottom end and insert baffle tab into slot on the top of the right bracket to lock into place. **Figure 37.3**. Place the left side hook at the bottom of the baffle over the top edge of brick for stability. **Figure 37.4**.
6. The baffle does not completely cover the top of the firebox. There is an opening on the left as shown in **Figure 37.5**.



**Figure 37.4**



**Figure 37.5**

Re-installing Baffle & Brick Set (Cont'd)

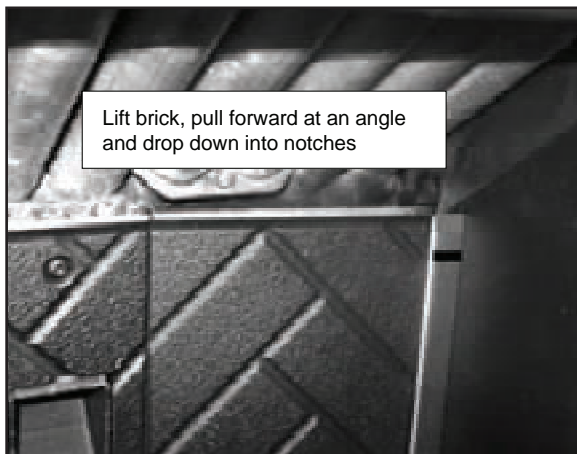


Figure 38.1

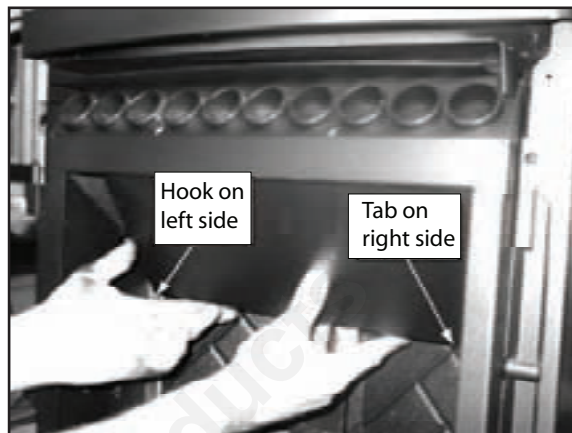


Figure 38.4



Figure 38.2



Figure 38.5



Figure 38.3

## 11

## Reference Materials



When describing the location of a component part it is always **AS YOU FACE THE FRONT OF THE APPLIANCE**.

## A. Component Function

1. Control Box

- The control box is located on lower right side of appliance, behind cast side on top of the junction box.
- There is a light located inside of the control box. The internal light will turn green when the appliance has reached a temperature of 200°F (93°C) in the firepot. and will turn red when it reaches 600°F (315°C).
- There is also an internal blue light located in the upper left corner of the control box. When you plug in the appliance the blue light will automatically start blinking 6 blinks every 10 seconds for 60 seconds and then will stop.

**NOTE:**

Do **NOT** open the control box. This will void the warranty. If you need to plug in or remove the control box you must first **unplug the appliance**.

2. Convection Blower

The convection blower is mounted at the bottom rear of the appliance. There are 2 impellers, one on each side of the motor. The convection blower pushes heated air through the heat exchange system into the room.

3. Exhaust Blower

The exhaust blower is mounted on the right side of the appliance behind the right cast side. The exhaust blower is designed to pull the exhaust from the appliance and push it out through the venting system.

4. Feed System

The feed system is located on the right side and can be removed as an entire assembly. The assembly includes the feed motor, mounting bracket, bearing and feed spring (auger). The hollow feed spring (auger) pulls pellets up the feed tube from the hopper area and drops them down the feed chute into the firepot.

5. Firepot

The firepot is made of high quality ductile iron and has a cleaning pull-out rod. The floor of the firepot opens for cleaning when you pull out the rod. Be sure that the floor returns to a completely closed position or your appliance will not operate properly.

6. Fuse

The fuse is located on the right side behind the control box. The fuse will blow should a short occur and shut off power to the appliance.

7. Heat Exchangers

The heat exchangers transfer heat from the exhaust system into convection air. There are 2 clean out rods located under the heat exchangers.

8. Heat Output Switch

The heat output switch is located on the lower right side of firebox, behind the right face above the reset button. The function of the heat output switch is to regulate the burn rates; low, medium and high settings.

9. Igniter

The igniter is mounted on the base of the firepot. Combustion air travels over the red hot igniter creating super heated air that ignites the pellets.

10. Junction Box And Wiring Harness

The junction box is located behind right cast side of the appliance. The junction box and wiring harness are replaced as one component.

11. Power Supply

The power outlet is located behind the right cast side of the appliance behind the thermostat block on the junction box. Check the wall receptacle for 120 volt, 60 Hz (standard current). Make sure the outlet is grounded and has the correct polarity. A good surge protector is recommended. When operating with a generator you need at least 600 watts of power, or with an inverter at least 800 watts of power available for the appliance during the start cycle.

12. Red Call Light

The red call light is located behind the fuse behind the right cast side. The function of the red call light is to indicate that the thermostat is calling for heat.

13. Reset Button

The reset button is located on the lower right side of firebox behind right face and below the heat output control switch. The function of the switch is to momentarily open the thermostat circuit, which restarts the system.

14. Thermocouple

The thermocouple is located on top of the firepot inside the thermocouple cover (ceramic protection tube). The thermocouple sends a millivolt signal to the control box indicating the preset temperatures of the green and red lights have been obtained.

15. Thermostat

The appliance is designed to run on a 12 volt AC thermostat. The heat anticipator, if present, should be set on the lowest setting available.

**16. Snap Disc #1 (Convection Blower) 110°F**

Snap disc #1 is located behind the right cast side of the firebox above the red call light. There are 2 purple wires connected to it. This snap disc turns the convection blower on and off as needed. Power is always present at snap disc #1.

**17. Snap Disc #2 (Fuel Delivery Interrupt) 250°F**

Snap disc #2 is located on the back side of the feed drop tube. There is 1 orange wire and 1 black wire connected to it. This snap disc will turn off the feed system, which will turn off the appliance if an overfire condition should occur or if the convection blower should fail to operate. If this occurs the snap disc will automatically reset itself.

**18. Snap Disc #3 (Burn Back Protector) 250°F**

Snap disc #3 is mounted on the back of the auger tube in the center of the appliance and has a reset button. To access it remove the right cast side. If the fire tries to burn back into the feed system or push exhaust up the feed tube, this snap disc will shut the entire system off. This disc must be manually reset.

**19. Vacuum Switch**

The vacuum switch is located at the back of the appliance. This switch turns the feed system on when vacuum is present in the firebox. The vacuum switch is a safety device to shut off the feed motor if the exhaust or the heat exchanger system is dirty or plugged or if the firebox door is open.

**20. Wiring Harness**

See Figure 40.1 below

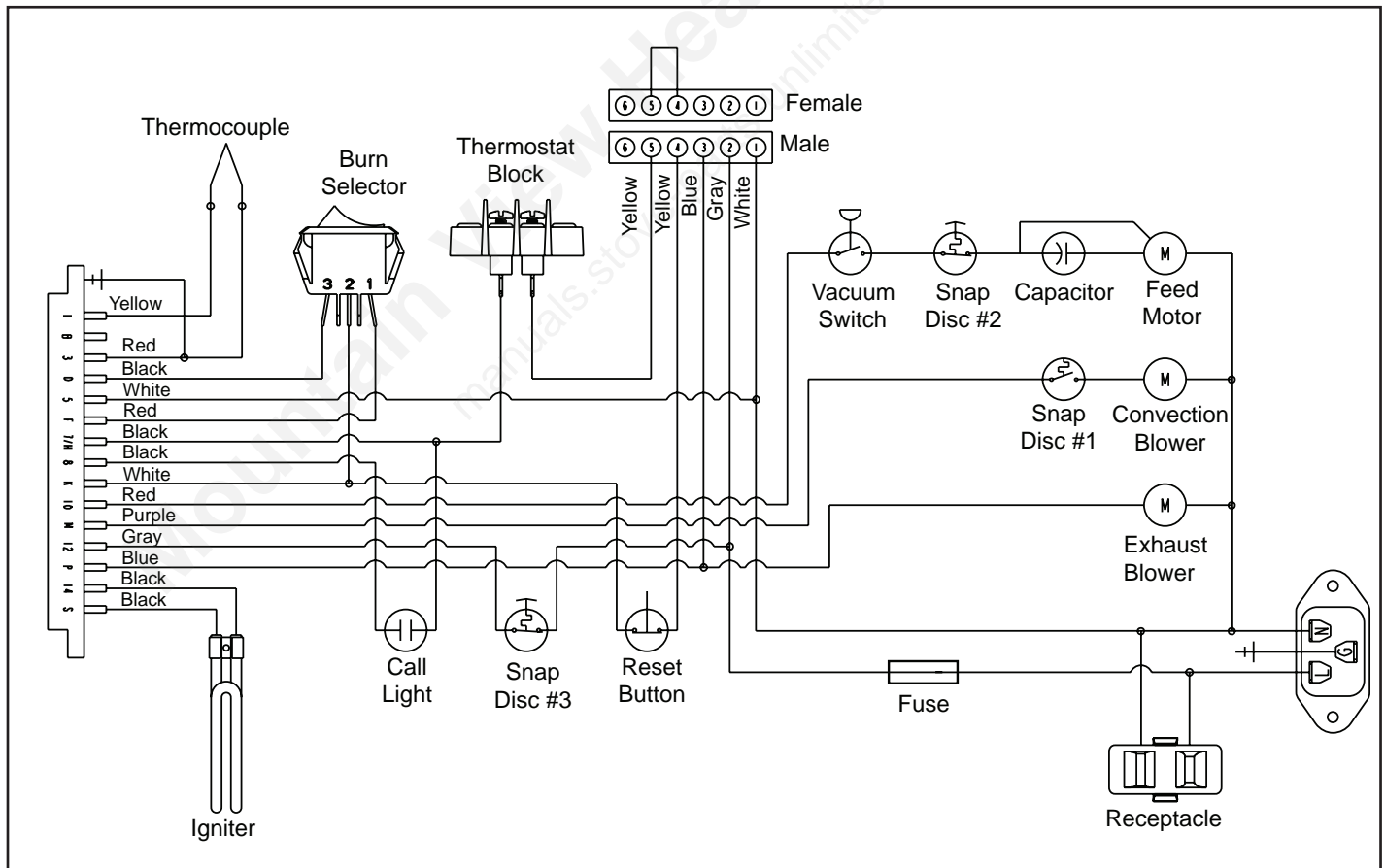
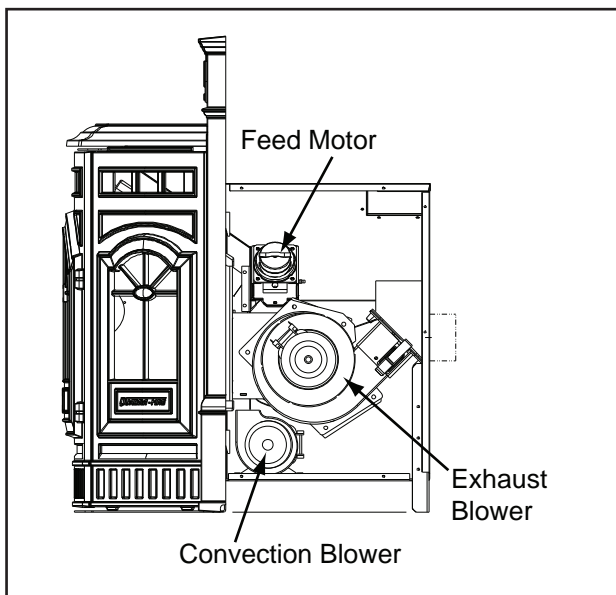
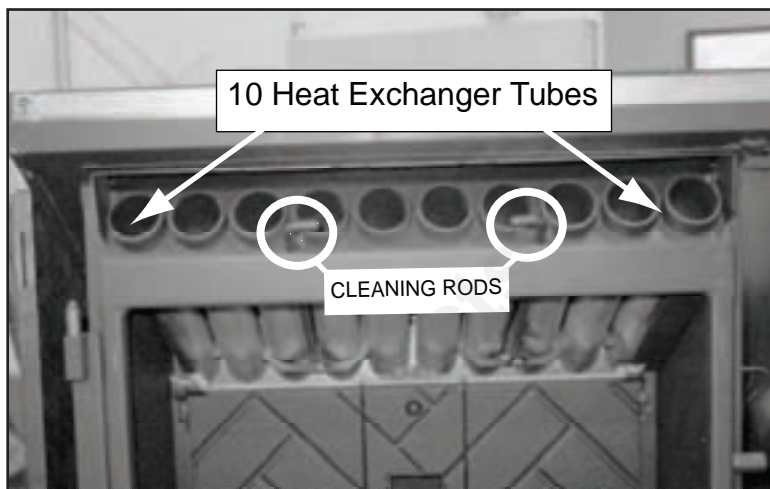


Figure 40.1

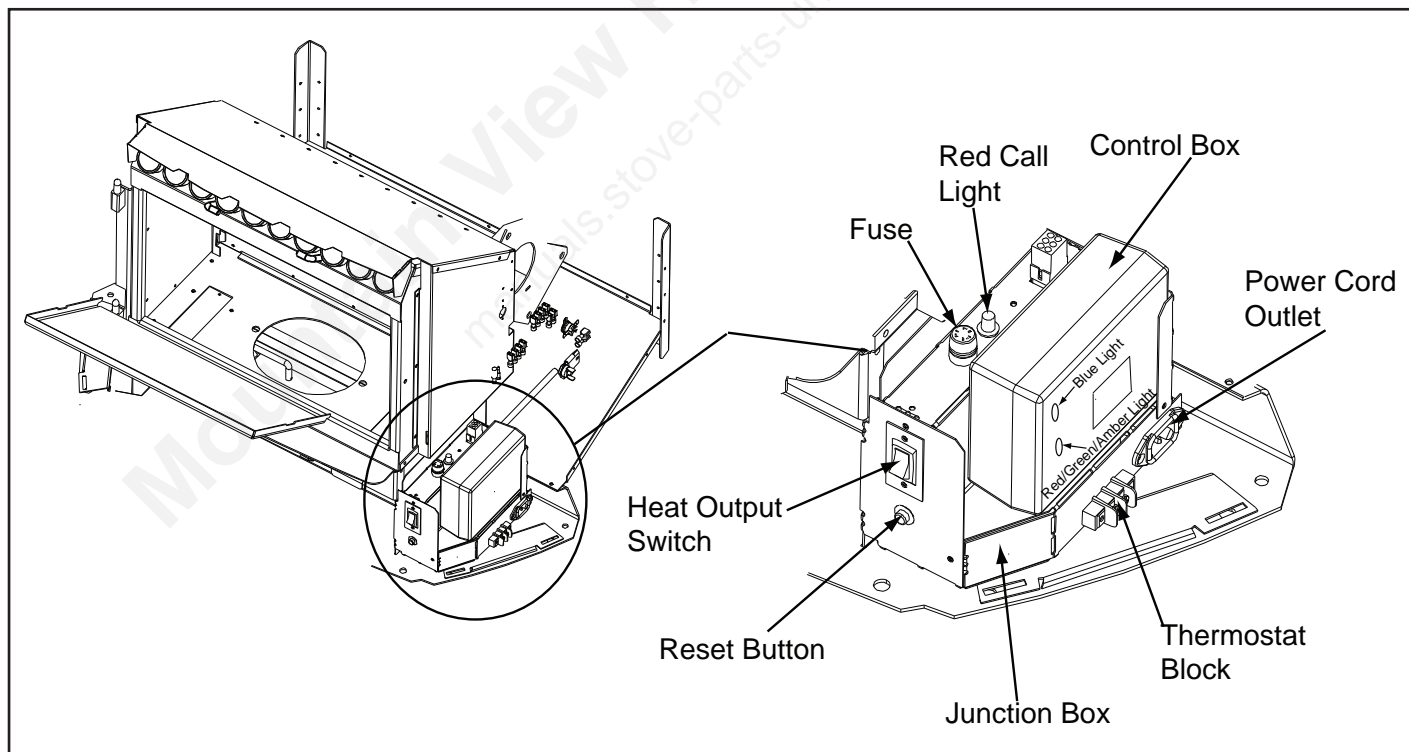
**B. Component Locations**



**Figure 41.1 - Blowers & Feed Motor**



**Figure 41.2 - Cleaning Rods & Heat Exchanger Tubes**



**Figure 41.3**

C. Exploded Drawing

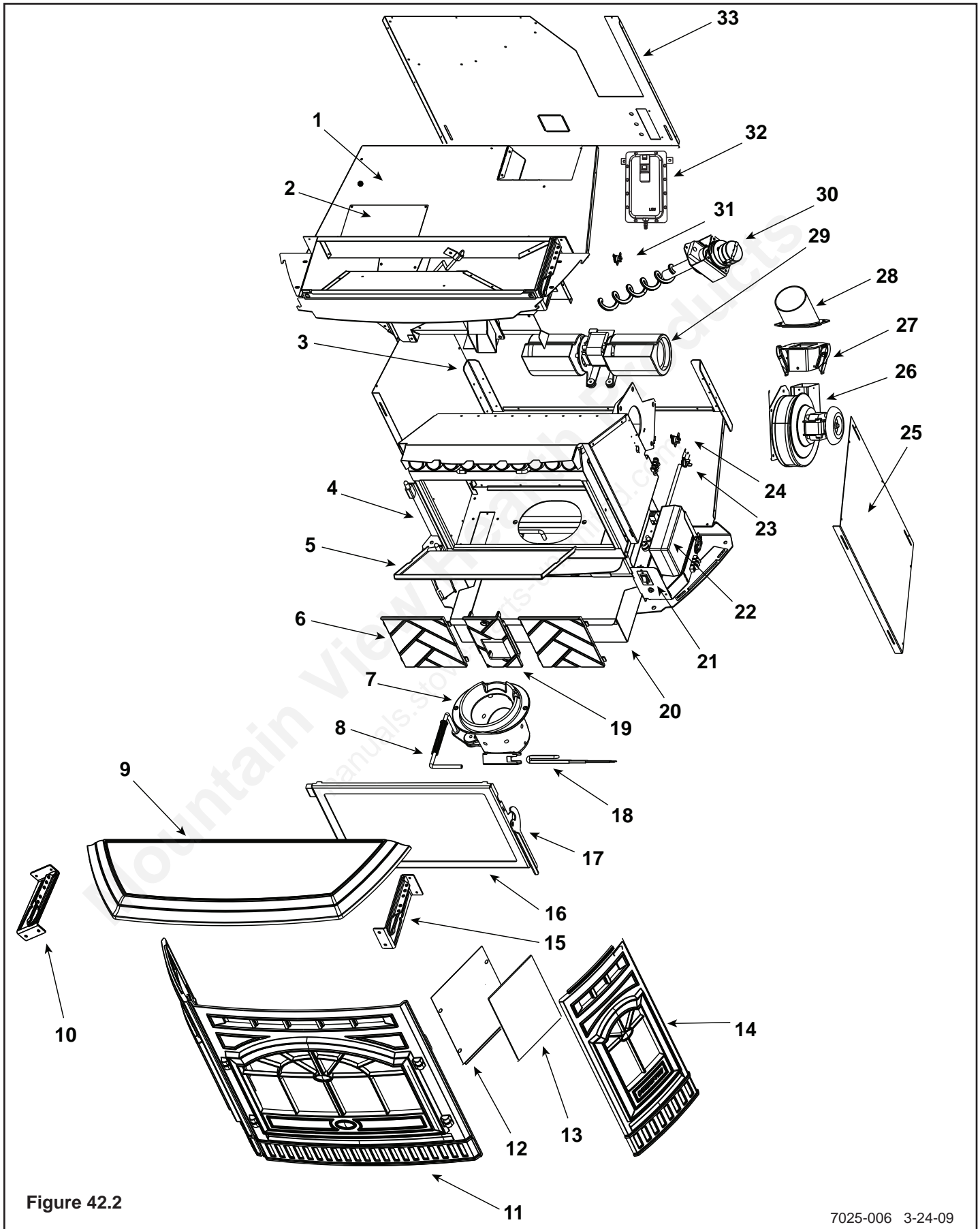


Figure 42.2

7025-006 3-24-09

**D. Service Parts and Accessories**

**IMPORTANT: THIS IS DATED INFORMATION**

When requesting service or replacement parts for your appliance please provide model number and serial number. All parts listed may be orderd from an authorized dealer.

**HOW TO ORDER**

To order the entire assembly, order the top line part number only. To order an individual part from an assembly, order the part(s) listed in the indented portion.



Item	Description	Comments	Part Number	Stocked at Depot
1	Hopper Top Assembly		SRV414-5830	
	Feed Adjustment Bracket Assembly		SRV414-6230	
2	Plate, Cover, Outer Can		480-1300	
3	Leveling Leg		SRV414-0210	
4	Bracket, Hinge	Attaches to Unit	SRV414-0610	
5	Baffle Assembly		UK-30KPEL	
6	Brick, Left / Right, Cast	Interchangeable	414-0270	
7	Firepot Assembly		SRV414-5200	Y
	Bushing, Firepot		410-8320	
	Floor, Firepot		414-0290	
	Gasket, Firepot		240-0930	Y
	Nut, Lock 1/4-20		226-0090	
	Bolt, Firepot, 1-1/4" Long		225-0120	
8	Pull Rod Assembly		414-5270	
	Clip, Hitch Pin, #25		229-0360	
	Spring, Firepot		200-2050	
9	Top Cast	Matte Black	414-0060BK	
		Must Specify Porcelain Color	414-0060POR	
		Must Specify Powder Coat Color	414-0060PWD	
10	Top Slide Assembly Left		414-5180	
11	Face	Matte Black	414-0040BK	
		Must Specify Porcelain Color	414-0040POR	
		Must Specify Powder Coat Color	414-0040PWD	
	Face Hinge	For Black Units	SRV414-0940	
		For Porcelain & Powder Coat Units	SRV414-0950	
12	Backer, Side Window	Interchangeable	414-0280	
13	Glass Assembly, Side, 1 Piece	5-7/8 in. W x 9 in. H, Interchangeable	414-5380	Y
	Gasket, Channel 1/8X1-1/4	Qty: 10 Ft., Field cut to size	7000-377/10	Y
	Speed Nut 5/16	Qty: 24	7000-422/24	Y
14	Side	Matte Black	414-0050BK	
		Must Specify Porcelain Color	414-0050POR	
		Must Specify Powder Coat Color	414-0050PWD	
15	Top Slide Assembly Right		414-5170	
16	Door Assembly	SN # 0071389650 & Above, Bottom Airwash	413-5110	
		SN # 0071389649 & Below, Top Airwash	414-5190	

**HOW TO ORDER**

To order the entire assembly, order the top line part number only.  
 To order an individual part from an assembly, order the part(s) listed in the indented portion.



**Stocked at Depot**

Item	Description	Comments	Part Number	Stocked at Depot
	Gasket, Tadpole, 3/8	Qty: 10 Ft., Field cut to size	842-5130	Y
	Glass Assembly	17-1/in. W x 11-5/8 in. H	7001-038	Y
	Hinge, Female		450-2910	
	Retainer, Rope		7001-192	
	Tape, Door Corner	Qty: 1 Ft., Field cut to size	SRV7027-227	
17	Door Latch Assembly		413-5200	
18	Heating Element Assembly 18" (Loop Igniter)	Qty: 1	SRV7000-462	Y
		Qty: 10	SRV7000-462/10	Y
	Washer, 1/4 Sae	Qty: 24	28758/24	Y
	Wing Thumb Screw 8-32X1/2	Qty: 24	7000-223/24	Y
19	Brick, Center, Cast		414-0260	
20	Ash Pan		414-0130	
21	Wire Harness		SRV414-1040	Y
	Capacitor, Rep Jumper		230-2150	
	Igniter Extension		7000-218	
22	Control Board 3 Speed		SRV7000-205	Y
23	Snap Disc, Manual Reset, # 3		SRV230-1290	Y
24	Snap Disc, 110-20		SRV230-1220	Y
25	Outer Skin		414-0500	
26	Blower, Exhaust Combustion		812-4400	Y
	Gasket, Exhaust Combustion Blower	Between Housing & Stove	240-0812	Y
		Between Housing & Motor (round)	812-4710	
27	Exhaust Transition Assembly		414-5100	
	Latch, Draw		229-0230	
28	Exhaust Adapter Assembly		414-5110	
	Gasket, Flue Adapter		240-0850	
29	Blower, Convection		812-4900	Y
	Blower Magnet		7019-188	
30	Feed Assembly		414-5400	
	Bearing, Feed System, Nylon		410-0552	
	Collar, Set, 7/8		229-0520	
	Feed Motor Bracket Assembly		7001-039	
	Feed Motor		812-4421	Y
	Feed Spring Assembly		SRV414-5540	Y
	Gasket, Feed Motor		240-0731	
	Plate, Feed Motor Mount		412-0240	
31	Snap Disc, Manual Reset, # 3	SN # 0071389337 & Above (on drop tube)	SRV7000-268	Y
		SN # 0071389336 & Below	SRV230-1290	Y
32	Vacuum Switch		SRV7000-447	Y
33	Hopper Back		SRV414-0320	

**HOW TO ORDER**

To order the entire assembly, order the top line part number only.  
 To order an individual part from an assembly, order the part(s) listed in the indented portion.



**Stocked at Depot**

Item	Description	Comments	Part Number	Stocked at Depot
	Ash Catcher		414-0150	
	Plate, Ash Cleanout		7001-186	
	Bracket, Magnet		414-0930	
	Bracket, Snap Disc		7005-253	
	Call Light Bulb	Old Style Junction Box	812-0760	Y
	Call Light Lens Cover	Old Style Junction Box	812-0750	Y
	Call Light, Fluorescent	SN # 1378393 & Above	SRV7000-122	
	Ceramic Nuts, (Igniter)	Qty: 2	812-0730	Y
		Qty: 12	812-0730/12	Y
	Component Pack Assembly (Includes Firepot Cleanout Tool, Touch-Up Paint, Power Cord, Thermostat Wire Harness, Owners Manual, Warranty Card, "How-To" Dvd	Matte Black	414-5390	
		Porcelain Mahogany	414-5460	
		Powder Coat Sienna Bronze	414-5510	
		Powder Coat Willow	414-5520	
	Cleanout Tool		414-1140	
	Dvd Original Energy Insert		7000-441	
	Paint Touch-Up	Matte Black	7000-304	
		Porcelain Mahogany	855-1450	
		Powder Coat Sienna Bronze	TOUCHUP-CSB	
		Powder Coat Willow	TOUCHUP-CWL	
	Power Cord		812-1180	
	Harness, Thermostat Wire		230-0810	
	Deflector, Bottom Airwash		413-0680	
	Fuse, 7 Amp, Junction Box	Qty: 1 Junction Box	812-0380	Y
		Qty: 10 Junction Box	812-0380/10	Y
	Fuse, 8 Amp, Control Box	Qty: 1 Control Box	812-3780	Y
		Qty: 10 Control Box	812-3780/10	Y
	Hinge, Door, Male		450-2810	
	Hook, Cast Mount		414-1010	
	Hose, Vacuum, 5/32 Id	QTY: 3 Ft, Field Cut to Size	SRV240-0450	Y
	Igniter Wire (5Ft) & (4) Ceramic Nuts		812-4520	Y
	Magnet Round		SRV7000-140	Y
	Switch, 3-Position	Heat Output, Rocker Switch	812-3500	Y
	Thermocouple		812-4470	Y
	Thermocouple Clamp		SRV7001-203	
	Thermocouple Cover	Qty: 1	812-1322	Y
		Qty: 10	812-4920	Y
	Thermocouple Grounding Kit		812-4980	
	Wire Harness Snap Disk		7001-224	

**HOW TO ORDER**

To order the entire assembly, order the top line part number only.  
 To order an individual part from an assembly, order the part(s) listed in the indented portion.



**Stocked  
at Depot**

Item	Description	ACCESSORIES	Part Number	Stocked at Depot
	Adjustable Hearth Support	12 in x 50 in, 2-10 in H	ADJSPT-12	
	Damper, 3 Inch	Tall Vertical Installs Only	PEL-DAMP3	
	Damper, 4 Inch	Tall Vertical Installs Only	PEL-DAMP4	
	Log Set	Qty: 4	811-0852	
	Log Front, Left		7001-231	
	Log Front, Right		7001-230	
	Log Rear, Left		7001-233	
	Log Rear, Right		7001-232	
	Log Top, Twig, Center	To Cover Firepot	811-0900	
	Outside Air Kit, Rear		811-0872	
	Channel, Air Intake		413-7040	
	Cover, Outside Air Kit, Floor		411-1071	
	Hose, Alum Flex, 2 Inch X 3 Ft	Qty: 3 Ft	200-0860	
	Outside Air Cap Assembly		7001-044	
	Outside Air Collar Assembly		7001-045	
	Trim Plate, Outside Air Kit		412-7100	
	Panel & Trim Set, Basic, Standard	With Gold Trim	811-0990	
	Bracket, -L-, Trim		832-0840	
	Component Pack		413-5270	
	Trim, Panel Set, Std, Gold	Gold Trim Set	811-0710	
	Panel Set, Large	Use With Cast Trim	811-0920	
	Component Pack	Fasteners & Instructions For Cast Trim	413-5260	
	Panel Set, Standard	Use With Cast Trim	811-0910	
	Component Pack	Fasteners & Instructions For Cast Trim	413-5260	
	Thermostat, Mechanical		812-3760	
	Thermostat, Programmable		811-0520	
	Trim Cast	Matte Black	811-0930	
		Porcelain Mahogany	811-0960	
		Powder Coat Sienna Bronze	TR-CAST-CSB	
		Powder Coat Willow	TR-CAST-CWL	
	Footer, Left	Matte Black	414-7090MBK	
		Porcelain Mahogany	414-7090PMH	
		Powder Coat Sienna Bronze	414-7090CSB	
		Powder Coat Willow	414-7090CWL	
	Footer, Right	Matte Black	414-7100MBK	
		Porcelain Mahogany	414-7100PMH	
		Powder Coat Sienna Bronze	414-7100CSB	
		Powder Coat Willow	414-7100CWL	

**HOW TO ORDER**

To order the entire assembly, order the top line part number only.  
To order an individual part from an assembly, order the part(s) listed in the indented portion.



**Stocked at Depot**

Item	Description	Comments	Part Number	Stocked at Depot
	Header	Matte Black	414-7110MBK	
		Porcelain Mahogany	414-7110PMH	
		Powder Coat Sienna Bronze	414-7110CSB	
		Powder Coat Willow	414-7110CWL	
	Trim Leg, Left	Matte Black	414-7120MBK	
		Porcelain Mahogany	414-7120PMH	
		Powder Coat Sienna Bronze	414-7120CSB	
		Powder Coat Willow	414-7120CWL	
	Trim Leg, Right	Matte Black	414-7130MBK	
		Porcelain Mahogany	414-7130PMH	
		Powder Coat Sienna Bronze	414-7130CSB	
		Powder Coat Willow	414-7130CWL	
	Zero Clearance, Adjustable Trim Support	For Standard Panel Surround Only	811-0980	
<b>FASTENERS</b>				
	Avk Rivnut Repair Kit	1/4-20 & 3/8-16 Rivnut Tools	RIVNUT-REPAIR	Y
	Bolt, Hex Head, 1/4-20 X 1	Qty: 10	25221A/10	Y
	Nut, Wing, 8-32	Qty: 24	226-0160/24	Y
	Screw, 1/4-20X3/8 Phillips Button Head	Qty: 24	7000-401/24	Y
	Screw Flat Head Screw 1/4-20	Qty: 24	7000-130/24	Y
	Screw, Pan Head Philips 8-32 X 3/8	Qty: 40	225-0500/40	Y
	Screw, Flat Head Philips 8-32X1/2	Qty: 10	832-0860	
	Screw, Pan Head Philips, 10/32 X 1/4	Qty: 24	229-1230/24	Y
	Screw, Sheet Metal #8 X 1/2 S-Grip	Qty: 40	12460/40	Y
	Screw, Machine Screw 1/4-20X5/8	Qty: 24	220-0440/24	Y
	Speed Nut 5/16	Qty: 24	7000-422/24	Y
	Washer, 1/4 Sae	Qty: 24	28758/24	Y
	Wing Thumb Screw 8-32X1/2	Qty: 24	7000-223/24	Y





**F. Warranty Policy**

**Hearth & Home Technologies Inc.  
LIMITED LIFETIME WARRANTY**

Hearth & Home Technologies Inc., on behalf of its hearth brands ("HHT"), extends the following warranty for HHT gas, wood, pellet, coal and electric hearth appliances that are purchased from an HHT authorized dealer.

**WARRANTY COVERAGE:**

HHT warrants to the original owner of the HHT appliance at the site of installation, and to any transferee taking ownership of the appliance at the site of installation within two years following the date of original purchase, that the HHT appliance will be free from defects in materials and workmanship at the time of manufacture. After installation, if covered components manufactured by HHT are found to be defective in materials or workmanship during the applicable warranty period, HHT will, at its option, repair or replace the covered components. HHT, at its own discretion, may fully discharge all of its obligations under such warranties by replacing the product itself or refunding the verified purchase price of the product itself. The maximum amount recoverable under this warranty is limited to the purchase price of the product. This warranty is subject to conditions, exclusions and limitations as described below.

**WARRANTY PERIOD:**

Warranty coverage begins on the date of installation. In the case of new home construction, warranty coverage begins on the date of first occupancy of the dwelling or six months after the sale of the product by an independent, authorized HHT dealer/ distributor, whichever occurs earlier. The warranty shall commence no later than 24 months following the date of product shipment from HHT, regardless of the installation or occupancy date. The warranty period for parts and labor for covered components is produced in the following table.

The term "Limited Lifetime" in the table below is defined as: 20 years from the beginning date of warranty coverage for gas appliances, and 10 years from the beginning date of warranty coverage for wood, pellet, and coal appliances. These time periods reflect the minimum expected useful lives of the designated components under normal operating conditions.

Warranty Period		HHT Manufactured Appliances and Venting							Components Covered
Parts	Labor	Gas	Wood	Pellet	EPA Wood	Coal	Electric	Venting	
1 Year		X	X	X	X	X	X	X	All parts and material except as covered by Conditions, Exclusions, and Limitations listed
2 years				X	X	X			Igniters, electronic components, and glass
		X	X	X	X	X			Factory-installed blowers
				X					Molded refractory panels
3 years				X					Firepots and burnpots
5 years	1 year			X	X				Castings and baffles
7 years	3 years		X	X	X				Manifold tubes, HHT chimney and termination
10 years	1 year	X							Burners, logs and refractory
Limited Lifetime	3 years	X	X	X	X	X			Firebox and heat exchanger
90 Days		X	X	X	X	X	X	X	All replacement parts beyond warranty period

See conditions, exclusions, and limitations on next page.

**WARRANTY CONDITIONS:**

- This warranty only covers HHT appliances that are purchased through an HHT authorized dealer or distributor. A list of HHT authorized dealers is available on the HHT branded websites.
- This warranty is only valid while the HHT appliance remains at the site of original installation.
- Contact your installing dealer for warranty service. If the installing dealer is unable to provide necessary parts, contact the nearest HHT authorized dealer or supplier. Additional service fees may apply if you are seeking warranty service from a dealer other than the dealer from whom you originally purchased the product.
- Check with your dealer in advance for any costs to you when arranging a warranty call. Travel and shipping charges for parts are not covered by this warranty.

**WARRANTY EXCLUSIONS:**

This warranty does not cover the following:

- Changes in surface finishes as a result of normal use. As a heating appliance, some changes in color of interior and exterior surface finishes may occur. This is not a flaw and is not covered under warranty.
- Damage to printed, plated, or enameled surfaces caused by fingerprints, accidents, misuse, scratches, melted items, or other external sources and residues left on the plated surfaces from the use of abrasive cleaners or polishes.
- Repair or replacement of parts that are subject to normal wear and tear during the warranty period. These parts include: paint, wood, pellet and coal gaskets; firebricks; grates; flame guides; and the discoloration of glass.
- Minor expansion, contraction, or movement of certain parts causing noise. These conditions are normal and complaints related to this noise are not covered by this warranty.
- Damages resulting from: (1) failure to install, operate, or maintain the appliance in accordance with the installation instructions, operating instructions, and listing agent identification label furnished with the appliance; (2) failure to install the appliance in accordance with local building codes; (3) shipping or improper handling; (4) improper operation, abuse, misuse, continued operation with damaged, corroded or failed components, accident, or improperly/incorrectly performed repairs; (5) environmental conditions, inadequate ventilation, negative pressure, or drafting caused by tightly sealed constructions, insufficient make-up air supply, or handling devices such as exhaust fans or forced air furnaces or other such causes; (6) use of fuels other than those specified in the operating instructions; (7) installation or use of components not supplied with the appliance or any other components not expressly authorized and approved by HHT; (8) modification of the appliance not expressly authorized and approved by HHT in writing; and/or (9) interruptions or fluctuations of electrical power supply to the appliance.
- Non-HHT venting components, hearth components or other accessories used in conjunction with the appliance.
- Any part of a pre-existing fireplace system in which an insert or a decorative gas appliance is installed.
- HHT's obligation under this warranty does not extend to the appliance's capability to heat the desired space. Information is provided to assist the consumer and the dealer in selecting the proper appliance for the application. Consideration must be given to appliance location and configuration, environmental conditions, insulation and air tightness of the structure.

**This warranty is void if:**

- The appliance has been over-fired or operated in atmospheres contaminated by chlorine, fluorine, or other damaging chemicals. Over-firing can be identified by, but not limited to, warped plates or tubes, rust colored cast iron, bubbling, cracking and discoloration of steel or enamel finishes.
- The appliance is subjected to prolonged periods of dampness or condensation.
- There is any damage to the appliance or other components due to water or weather damage which is the result of, but not limited to, improper chimney or venting installation.

**LIMITATIONS OF LIABILITY:**

- The owner's exclusive remedy and HHT's sole obligation under this warranty, under any other warranty, express or implied, or in contract, tort or otherwise, shall be limited to replacement, repair, or refund, as specified above. In no event will HHT be liable for any incidental or consequential damages caused by defects in the appliance. Some states do not allow exclusions or limitation of incidental or consequential damages, so these limitations may not apply to you. This warranty gives you specific rights; you may also have other rights, which vary from state to state. EXCEPT TO THE EXTENT PROVIDED BY LAW, HHT MAKES NO EXPRESS WARRANTIES OTHER THAN THE WARRANTY SPECIFIED HEREIN. THE DURATION OF ANY IMPLIED WARRANTY IS LIMITED TO DURATION OF THE EXPRESSED WARRANTY SPECIFIED ABOVE.

# QUADRA-FIRE®

## CONTACT INFORMATION:

Hearth & Home Technologies  
1445 North Highway  
Colville, WA 99114  
Division of HNI INDUSTRIES

Please contact your Quadra-Fire dealer with any questions or concerns.  
For the number of your nearest Quadra-Fire dealer  
please visit our web site at [www.quadrafire.com](http://www.quadrafire.com)

### NOTICE



#### DO NOT DISCARD THIS MANUAL

- Important operating and maintenance instructions included.
- Read, understand and follow these instructions for safe installation and operation.
- Leave this manual with party responsible for use and operation.



We recommend that you record the following pertinent information for your CASTILE PELLETT INSERT

Date purchased/installed: \_\_\_\_\_

Serial Number: \_\_\_\_\_ Location on appliance: \_\_\_\_\_

Dealership purchased from: \_\_\_\_\_ Dealer phone: \_\_\_\_\_

Notes: \_\_\_\_\_

\_\_\_\_\_  
\_\_\_\_\_

This product may be covered by one or more of the following patents: (United States) 4593510, 4686807, 4766876, 4793322, 4811534, 5000162, 5016609, 5076254, 5113843, 5191877, 5218953, 5263471, 5328356, 5341794, 5347983, 5429495, 5452708, 5542407, 5601073, 5613487, 5647340, 5688568, 5762062, 5775408, 5890485, 5931661, 5941237, 5947112, 5996575, 6006743, 6019099, 6048195, 6053165, 6145502, 6170481, 6237588, 6296474, 6374822, 6413079, 6439226, 6484712, 6543698, 6550687, 6601579, 6672860, 6688302B2, 6715724B2, 6729551, 6736133, 6748940, 6748942, 6769426, 6774802, 6796302, 6840261, 6848441, 6863064, 6866205, 6869278, 6875012, 6880275, 6908039, 6919884, D320652, D445174, D462436; (Canada) 1297749, 2195264, 2225408, 2313972; (Australia) 780250, 780403, 1418504 or other U.S. and foreign patents pending.

