

QUADRA-FIRE[®]

NOTHING BURNS LIKE A QUAD

MT VERNON-AE

TROUBLE SHOOTING MANUAL



HEARTH & HOME
technologies[™]

(THIS MANUAL IS INTENDED FOR TRAINED & QUALIFIED DEALER USE ONLY)

1445 N. Highway
Colville, Wa 99114

#7020-057C April 28th, 2008

www.quadrafire.com
www.quaddealer.com

MT VERNON-AE TROUBLE SHOOTING MANUAL

TABLE OF CONTENTS

<u>SECTION</u>	<u>PAGE</u>
OPERATION.....	3-5
BATTERY BACK-UP SYSTEM.....	6
CONTROL BOARD SPECS.....	7
ERROR CODES.....	8
OPERATIONAL SYMPTOMS.....	9
CONVECTION BLOWER TROUBLE-SHOOTING.....	10
EXHAUST BLOWER TROUBLE-SHOOTING.....	11
FEED MOTOR TROUBLE-SHOOTING.....	12
FIRE POT, AUTOCLEAN, THERMOCOUPLE TROUBLE-SHOOTING.	13-14
IGNITER TROUBLE-SHOOTING.....	15
POWER SUPPLY TROUBLE-SHOOTING.....	16
DOOR/HOPPER/FUEL LEVEL SENSOR TESTING.....	17
WALL CONTROL TROUBLE-SHOOTING.....	18
USB CORD OPERATION.....	19
CLEANING & MAINTENANCE.....	20
PARTS LIST.....	23
EXPLODED VIEW.....	24

TECHNICAL SERVICES DEPARTMENT

PHONE: 866-804-7783

FAX: 877-703-1084 (office)

WARRANTY CLAIMS FAX: 866-700-9924

MT VERNON-AE TROUBLE SHOOTING MANUAL

OPERATION CHART

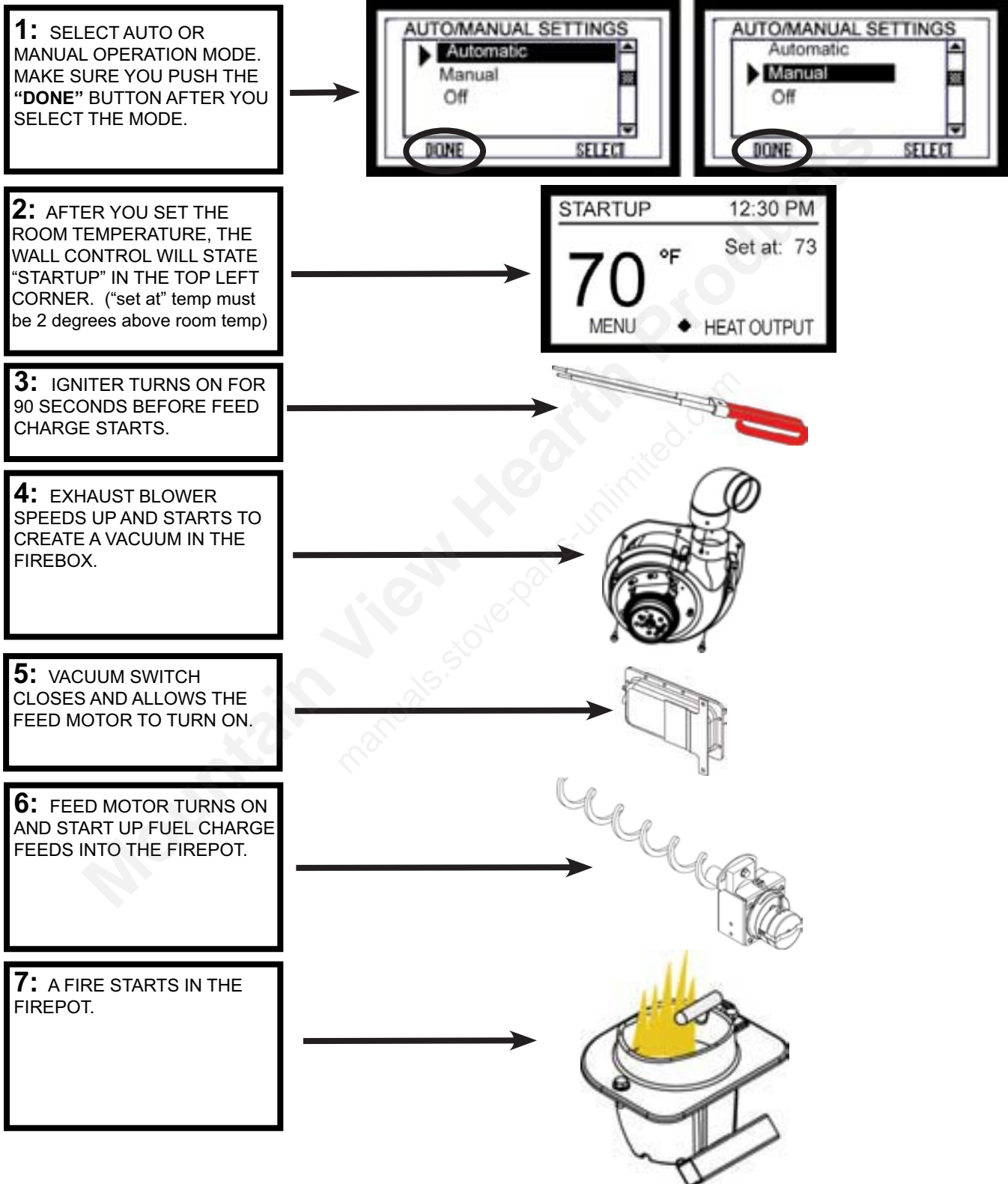

MT VERNON-AE TROUBLE SHOOTING MANUAL

OPERATION CHART

8: THE FIREPOT THERMOCOUPLE STARTS READING THE TEMPERATURE RISE AND THE UNIT WILL GO INTO "SOFT-START LOW".

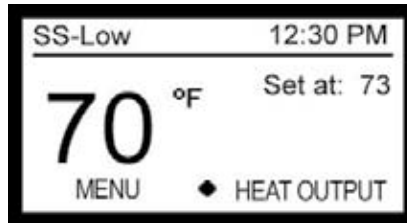

9: SOFT-START LOW IS A TIMED MODE AND WILL VARY IN LENGTH DEPENDING ON THE FUEL TABLE SELECTED.

SOFT-START LOW TIMES:

SOFTWOOD.....	4 MINUTES
HARDWOOD.....	4 MINUTES
UTILITY.....	4 MINUTES
CORN.....	14 MINUTES
WHEAT.....	10 MINUTES
SUNFLOWER SEEDS.....	4 MINUTES

10: THE IGNITER WILL SHUT OFF AFTER SOFT START LOW EXPIRES.



11: SOFT-START MEDIUM WILL DISPLAY AFTER SOFT START LOW HAS EXPIRED. THE LENGTH OF THIS MODE WILL VARY DEPENDING ON THE FUEL SELECTED.

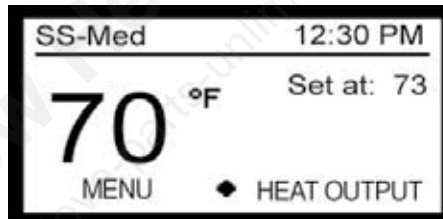

SOFT-START MEDIUM TIMES:

SOFTWOOD.....	5 MINUTES
HARDWOOD.....	5 MINUTES
UTILITY.....	5 MINUTES
CORN.....	12 MINUTES
WHEAT.....	10 MINUTES
SUNFLOWER SEEDS.....	5 MINUTES

12: THE DROP TUBE THERMOCOUPLE WILL BEGIN READING TEMPERATURE. 105 DEGREES WILL BE NEEDED TO TURN THE CONVECTION BLOWER ON.



13: AS THE TEMPERATURE RISES, THE CONVECTION BLOWER WILL INCREASE IN SPEED.



MT VERNON-AE TROUBLE SHOOTING MANUAL

OPERATION CHART

14: THE WALL CONTROL WILL NOW DISPLAY THE HEAT OUTPUT SETTING IN THE MANUAL OR AUTO MODE.
 AUTO: (L,ML,M,MH,H)
 MAN: (L,ML,M,MH,H)



15: ONCE THE THERMOSTAT IS SATISFIED OR THE BURN CYCLE HAS TIMED OUT FOR AN AUTO-CLEAN CYCLE, THE FEED MOTOR WILL SHUT OFF.

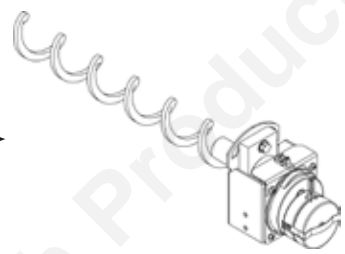

16: THE UNIT WILL GO INTO "SHUTDOWN" MODE. THIS MODE WILL LAST FOR 10 MINUTES. THE DROP TUBE T-COUPLE WILL ALSO COOL DOWN AND REDUCE THE SPEED OF THE CONVECTION BLOWER.

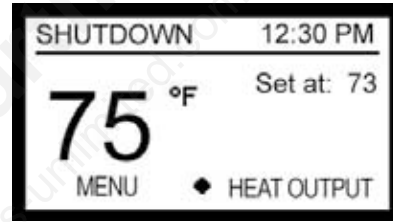

17: THE UNIT WILL DISPLAY "AUTOCLEAN" IN THE UPPER LEFT HAND CORNER.

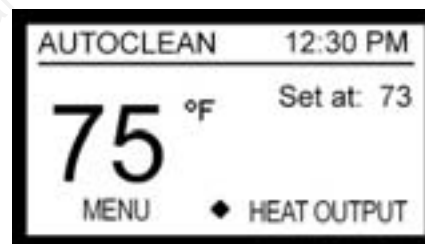

18: THE THERMOCOUPLE HAS TO READ 550 DEGREES OR LESS BEFORE THE AUTO-CLEAN CYCLE BEGINS.

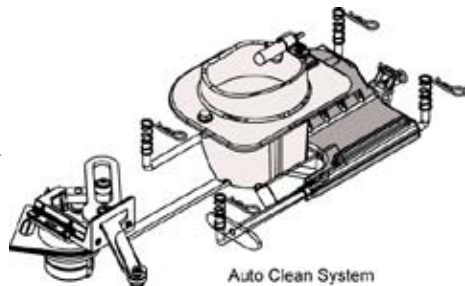

19: AFTER THE AUTO-CLEAN IS COMPLETE, THE EXHAUST BLOWER WILL RUN FOR 20 MINS AND SHUT OFF. UNIT IS READY TO START ANOTHER BURN CYCLE.

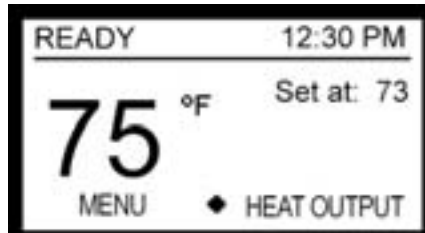

MT VERNON-AE TROUBLE SHOOTING MANUAL

BATTERY BACK-UP SYSTEM

12 VOLT DEEP CYCLE BATTERY AND THE BATTERY CORD (#12VCORD-AE) IS NEEDED TO POWER THE SYSTEM.

A/C POWER MUST BE SHUT OFF OR THE POWER CORD DISCONNECTED FOR THE BATTERY BACK UP MODE TO ENGAGE. THE WALL CONTROL WILL WALK YOU THROUGH THE LIGHT-UP PROCEDURES.

(Note: Igniter will not work during battery operation)

MANUAL LIGHT PROCEDURE
Press "CONTINUE"
button to start manual
lighting sequence
Current Temp: 72 F
CONTINUE

MANUAL LIGHT PROCEDURE
Please wait while
feed charge is loading
into firepot

MANUAL LIGHT PROCEDURE
Open door...
Manually light fuel...
Close door

MAINT BURN 12:30 PM
72.5 °F Set pt. 73
MENU HEAT OUTPUT

MAINT BURN WILL DISPLAY WHEN THE THERMOSTAT HAS REACHED THE SET ROOM TEMPERATURE AND WILL RUN ON LOW UNTIL IT REACHES ITS AUTOCLEAN CYCLE TIME.

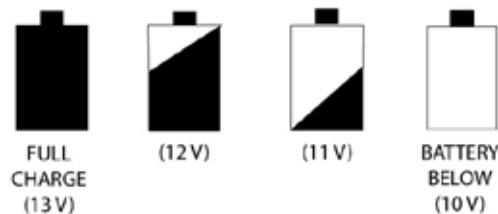

BATTERY WILL NEED TO BE CHANGED OR CHARGED WHEN VOLTAGE DROPS BELOW 10.

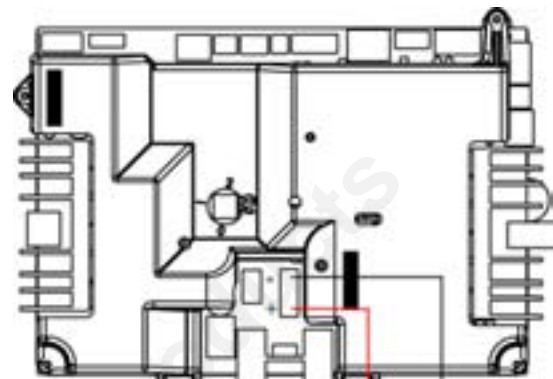

CONTROL BOARD

12 volt battery plug

PN# 12VCORD-AE (72 inches long)

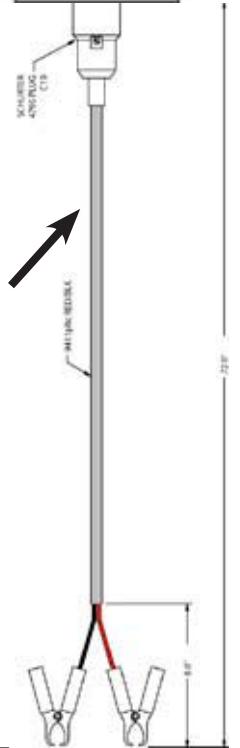

12 volt battery

(Estimated amp draw is between 3 & 6 amps during operation)

MT VERNON-AE TROUBLE SHOOTING MANUAL

CONTROL BOARD SRV7000-456 Rev C

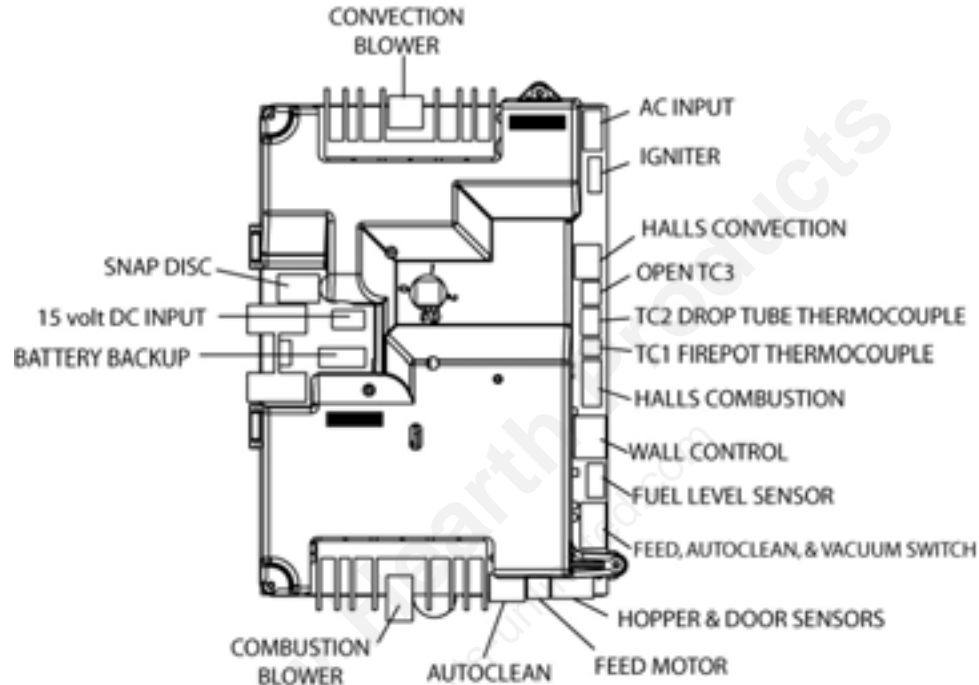

CONTROL BOARD SPECS 7.5 CODE: (Rev 2 fuel tables)

FUEL	UFTI	SS LOW	SS MED	MAX IGNITER TIME	A/C CYCLE TIME	SHUTDOWN TIME
CORN:	0	14 MIN	12 MIN	14 MIN	2.4 HRS*	10 MIN
UTILITY PELLET:	1	4 MIN	5 MIN	4 MIN	1.2 HRS*	10 MIN
SOFTWOOD:	2	4 MIN	5 MIN	4 MIN	3.2 HRS*	10 MIN
SUNFLOWER SEEDS:	3	4 MIN	5 MIN	4 MIN	2.4 HRS*	10 MIN
WHEAT:	4	10 MIN	10 MIN	10 MIN	1.8 HRS*	10 MIN
HARDWOOD PELLETS:	5	4 MIN	5 MIN	4 MIN	2.1 HRS*	10 MIN

*NOTE: AUTOCLEAN CYCLES TIMES ARE ESTIMATED WHEN THE UNIT IS RUN AT THE "HIGH" OUTPUT SETTING.

UPDATES:

SRV7000-323

ECO 56401 --- CHANGED FROM **6.9 TO 6.10A CODE**. INSTALLED POWER STROKE CODE FOR AUTOCLEAN AND CHANGED TO THE "QUIET" CONVECTION BLOWER CURVE. REV 2 FUEL TABLES ALSO INSTALLED. (1-11-07)

SRV7000-330

ECO 56476 -- RELEASED WITH THE **7.2 CODE**. HIGH ELEVATION FUEL TABLES INSTALLED. 2 CONVECTION BLOWER SPEED OPTIONS INSTALLED, 135 & 165 DEGREES TO GET TO THE HIGH BLOWER SPEED & EXHAUST BLOWER STAYS ON DURING THE AUTO-CLEAN CYCLE AND 20 MINUTES AFTER AUTO-CLEAN IS COMPLETED. (8-2-07 // SN 0072232364 INSERT /// SN 0072279399 FS)

SRV7000-456

ECO 58315 -- RELEASED WITH THE **7.3 CODE**. MADE SOME UPDATES TO THE EURO FUEL TABLES. (They can be accessed by turning the rotary switch to position 1)

REV B --- RELEASED WITH THE **7.4 CODE**. ADDRESSED PREVIOUS AUTO-CLEAN PROBLEMS. SN 00700200343

REV C --- RELEASED WITH THE **7.5 CODE**. ADDRESSED LOGIC PROBLEM WITH VAC SWITCH & AUGER JAM.



ERROR CODES



AUGER JAMMED: SEE PAGE 12 (FEED MOTOR TROUBLE-SHOOTING)

BAD TC DROP TUBE: SEE PAGE 10 (CONVECTION BLOWER TROUBLE-SHOOTING)

BAD TC FIRE POT: SEE PAGE 14 (FIREPOT, AUTOCLEAN & T-Couple TROUBLE-SHOOTING)

CHECK ASH PAN: SEE PAGE 13 (FIREPOT, AUTOCLEAN & T-Couple TROUBLE-SHOOTING)

COMB BLOWER JAMMED: SEE PAGE 11 (EXHAUST BLOWER TROUBLE-SHOOTING)

CONV BLOWER JAMMED: SEE PAGE 10 (CONVECTION BLOWER TROUBLE-SHOOTING)

MIN FP TEMP: UNIT IS OUT OF FUEL OR CHECK FOR PROPER FUEL SETTINGS. THIS CODE WOULD DISPLAY ANYTIME THE FIRE GOT UNDER 500 DEGREES DURING ITS NORMAL RUN MODE.

MISSED IGNITION: UNIT IS OUT OF FUEL OR CHECK FOR PROPER FUEL SETTINGS. SEE PAGE 14 (IGNITER TROUBLE-SHOOTING) THIS CODE WOULD DISPLAY IF THE FUEL DID NOT LIGHT OR THE FIRE DID NOT GET HOT ENOUGH DURING **START-UP** AFTER 4 TRIES.

VACUUM SW ERROR: SEE PAGE 12 (FEED MOTOR TROUBLE-SHOOTING)

MT VERNON-AE TROUBLE SHOOTING MANUAL



OPERATIONAL SYMPTOMS



UNIT HAS NO POWER OR LOSES POWER AFTER 15 TO 20 MINUTES: *SEE PAGE 16* (POWER SUPPLY TROUBLE-SHOOTING)

UNIT IS MAKING A RUMBLING NOISE DURING START-UP: CHECK THE FUEL SETTINGS AND MAKE SURE THE UNIT IS CLEAN. *SEE PAGE 20* (CLEANING & MAINTENANCE)

UNIT IS BUILDING UP BLACK SOOT ON THE GLASS: CHECK THE FUEL SETTINGS AND MAKE SURE THE UNIT IS CLEAN. *SEE PAGE 20* (CLEANING & MAINTENANCE)

IGNITER IS NOT GETTING HOT: *SEE PAGE 15* (IGNITER TROUBLE-SHOOTING). ENSURE THE IGNITER CHAMBER UPDATE HAS BEEN DONE. REFERENCE THE SEPT. 18, 2007 FIELD COMMUNICATION.

UNIT LIGHTS AND GOES OUT DURING START-UP: *SEE PAGE 13* (FIREPOT & AUTOCLEAN TROUBLE-SHOOTING)

UNIT WILL NOT LIGHT & BURN CORN CONSISTENTLY: CHECK FUEL SETTINGS. CORN MUST BE SCREENED. *SEE PAGE 13* (FIREPOT & AUTOCLEAN TROUBLE-SHOOTING)

WALL CONTROL SCREEN IS SHUTTING OFF: *SEE PAGE 18* (WALL CONTROL TESTING)

CONVECTION BLOWER TROUBLE-SHOOTING

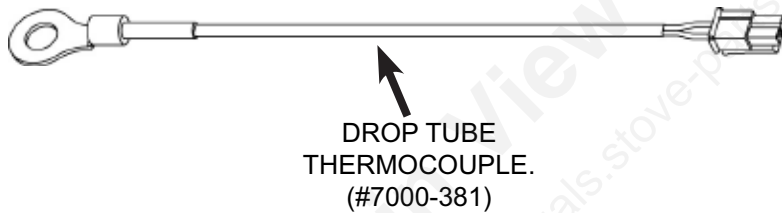
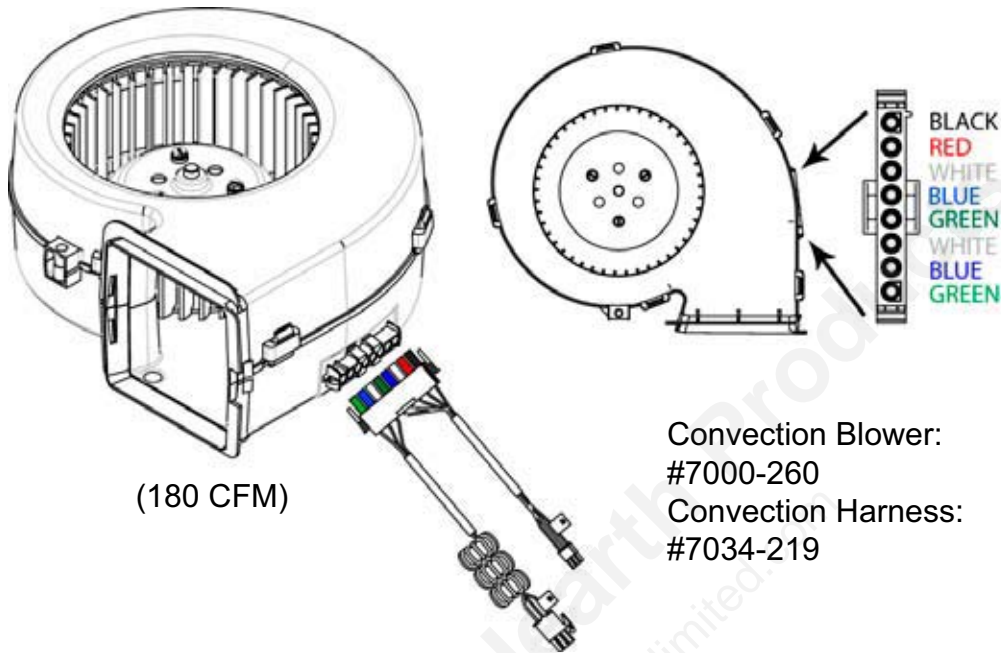

Items to check:

Check blower for obstructions:

*Clean fan blades & check fan bearing.

Check blower connections (#7034-219)

*Color of wires, Connector pins, test for broken wires

Check over heat snap disc (#230-1290)

*This is located on the pellet drop chute. Is it tripped?

Check drop tube thermocouple (#7000-381)

*This has to produce millivolts to turn the blower on.

Replace convection blower (#7000-260)

*If all previous checks are good, replace the blower.

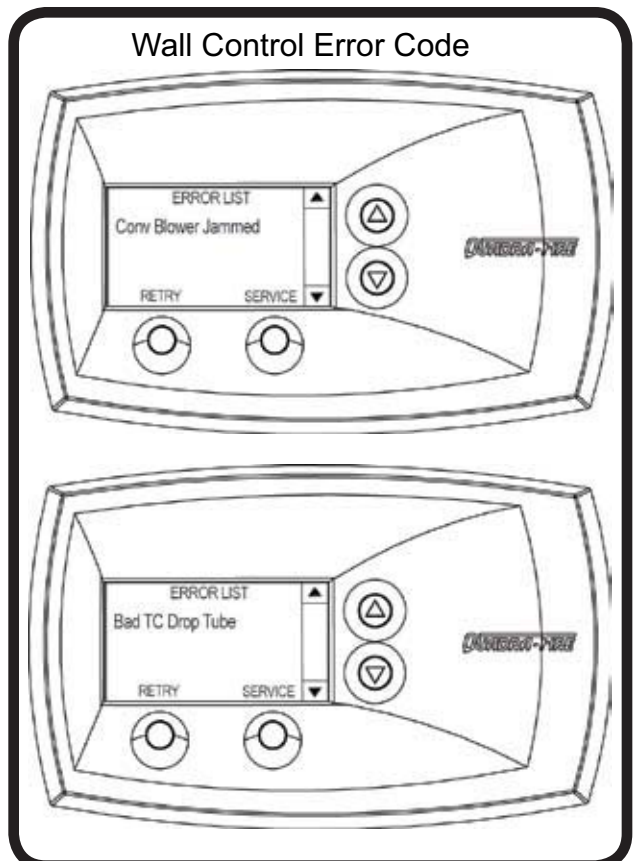

EXHAUST BLOWER TROUBLE-SHOOTING

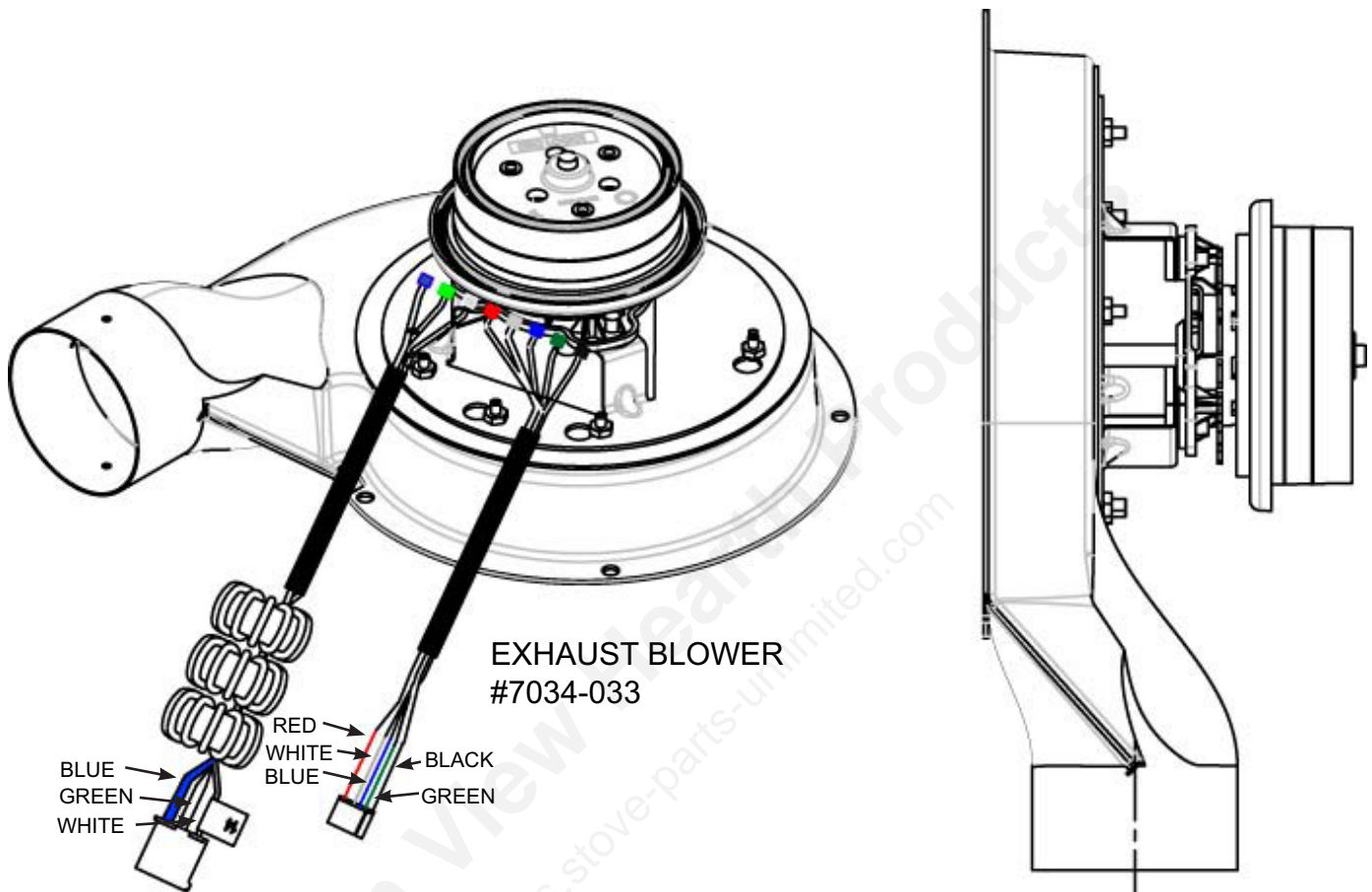

Items to check:

Check blower for obstructions:

*Clean fan blades & check fan bearing.

Check blower connections

*Color of wires, Connector pins, test for broken wires

Check over heat snap disc (#230-1290)

*This is located on the pellet drop chute. Is it tripped?

Replace exhaust blower (#7034-033)

*If all previous checks are good, replace the blower.

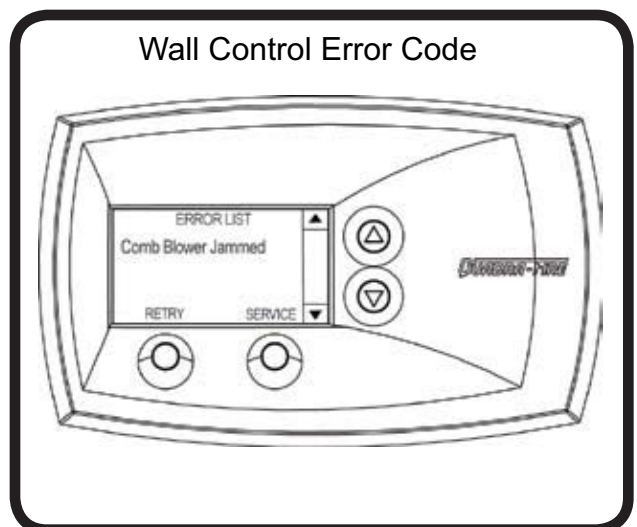

FEED MOTOR TROUBLE-SHOOTING

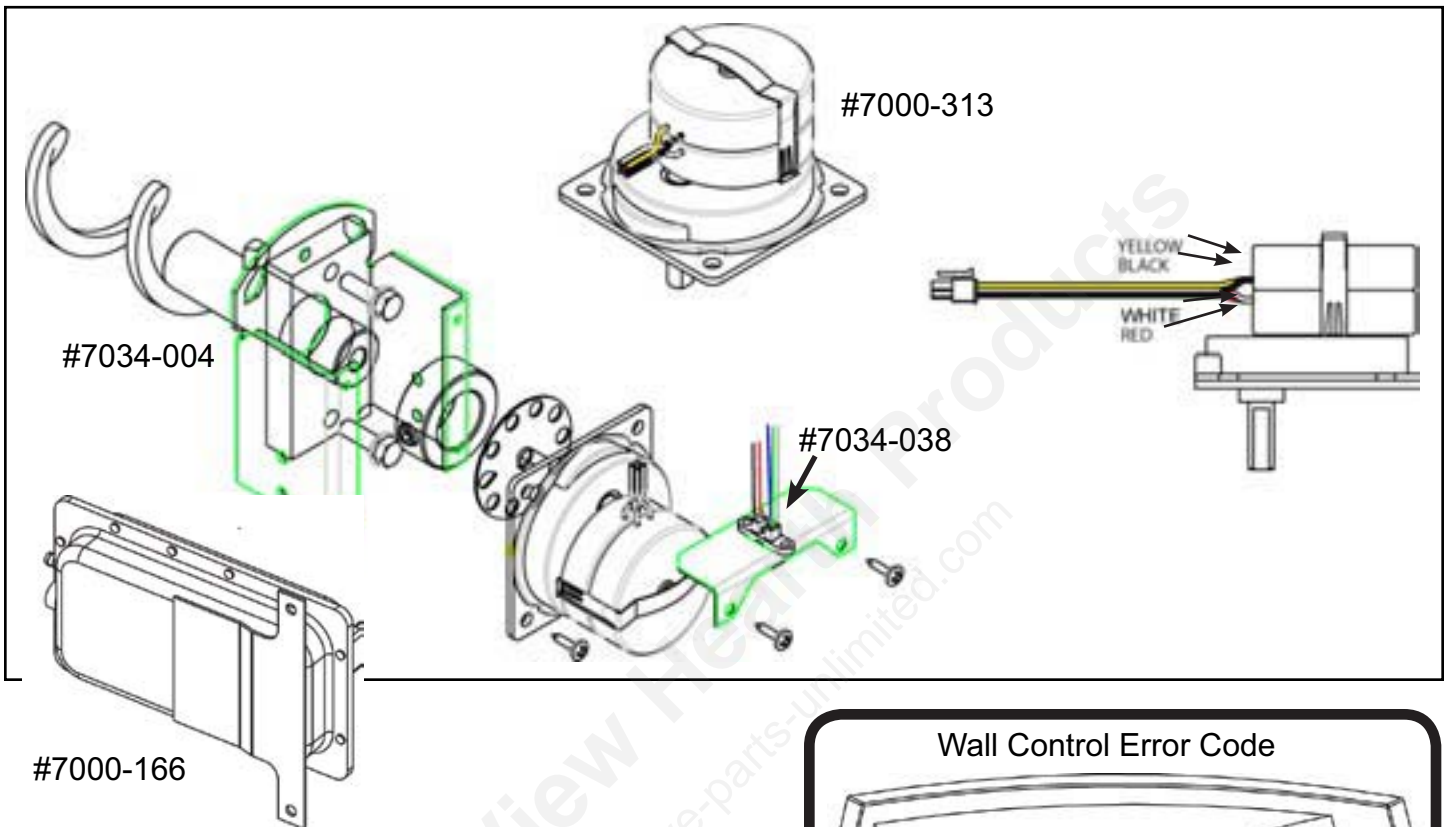

Items to check:

Check feed tube for obstructions:

*Remove the pellets from the hopper & then remove the feed assy (#7034-004).

Check the auger spring set screw:

*The set screw must be tight on the feed motor shaft.

Check the Door & Hopper sensors (#7000-375):

*Make sure the door & hopper lid is closed and the icons on the wall control are not displayed.

Check over heat snap disc (#230-1290):

*This is located on the pellet drop chute. Is it tripped?

Check the vacuum switch (#7000-166):

*Check for an error code or test the vacuum switch.

Replace the optical sensor (#7034-038):

*Replace this part if all previous checks are good.

Replace the feed motor (#7000-313):

*Replace this part if all previous checks are good.

Check the 10-pin harness for a loose pin or broken wire:

*Replace the harness if broken. (SRV7034-191)

Wall Control Error Code

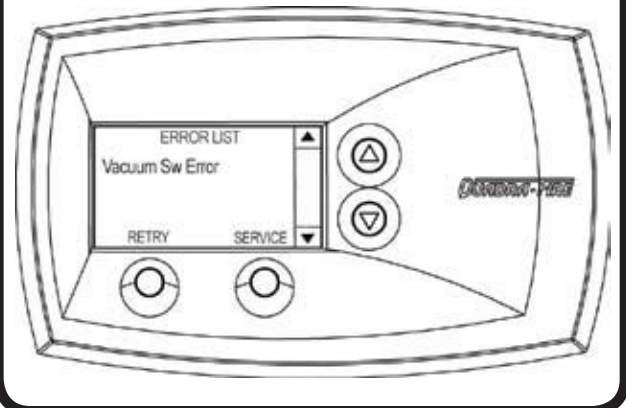
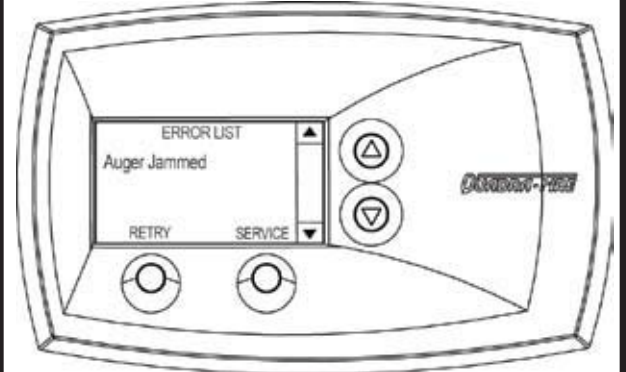

MT VERNON-AE TROUBLE SHOOTING MANUAL

FIREPOT, AUTOCLEAN, & THERMOCOUPLE TROUBLE-SHOOTING

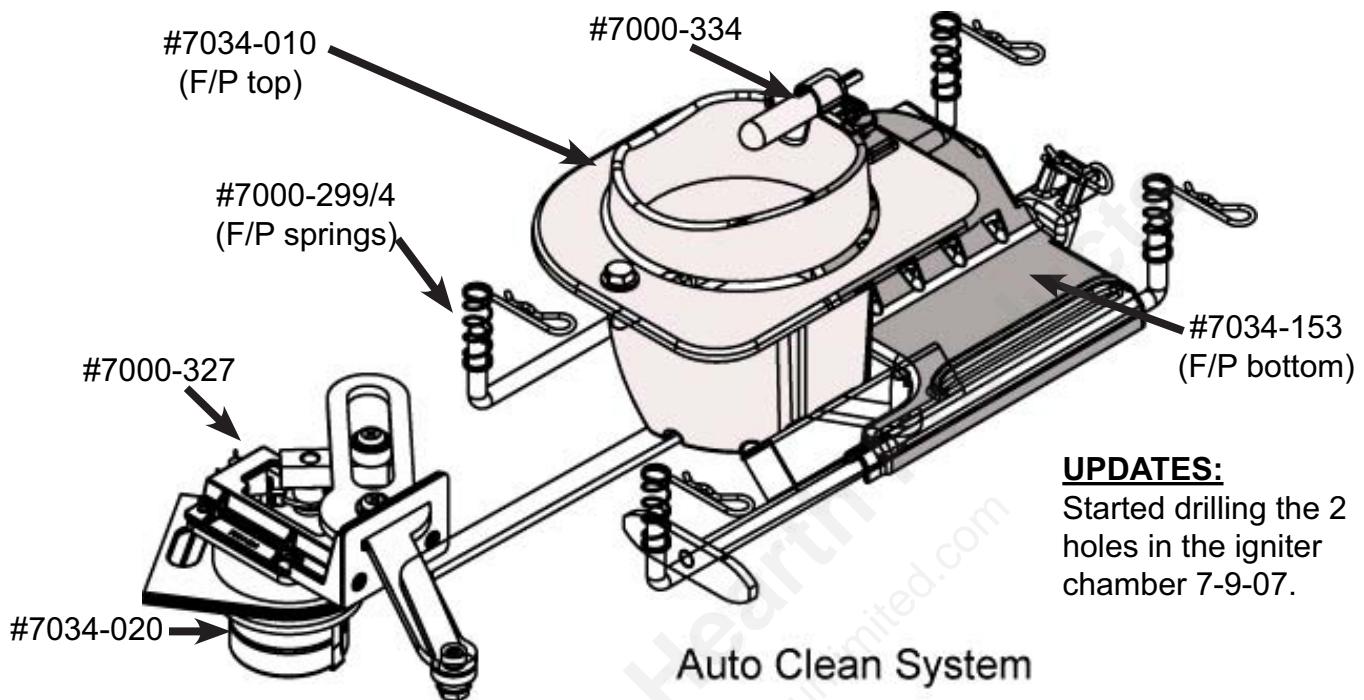

UPDATES:

Started drilling the 2 holes in the igniter chamber 7-9-07.

Items to check:

Check the door sensor (#7000-375):

*Make sure the door is closed and the icon on the wall control is not displayed.

Check over heat snap disc (#230-1290):

*This is located on the pellet drop chute. Is it tripped?

Check the ash pan & firepot for obstructions:

*Check for clinker blockage.

Check the version of control board (SRV7000-456):

*Replace this part if it is not at least a Rev C or higher.

Check firepot thermocouple (#7000-334):

*Check for millivolt output or replace (see page 14)

Check the auto-clean microswitch (#7000-327):

*Check the switch for an "open" & "closed" reading.

*Check for a loose connection on the switch wires.

Check for a broken wire on the 10 pin connector:

*Replace harness if broken. (SRV7034-191)

Check the auto-clean motor. (#7034-020):

*If all previous checks are good, replace the motor.

NOTE: The auto-clean system will cycle each time when the unit is unplugged and plugged back in.

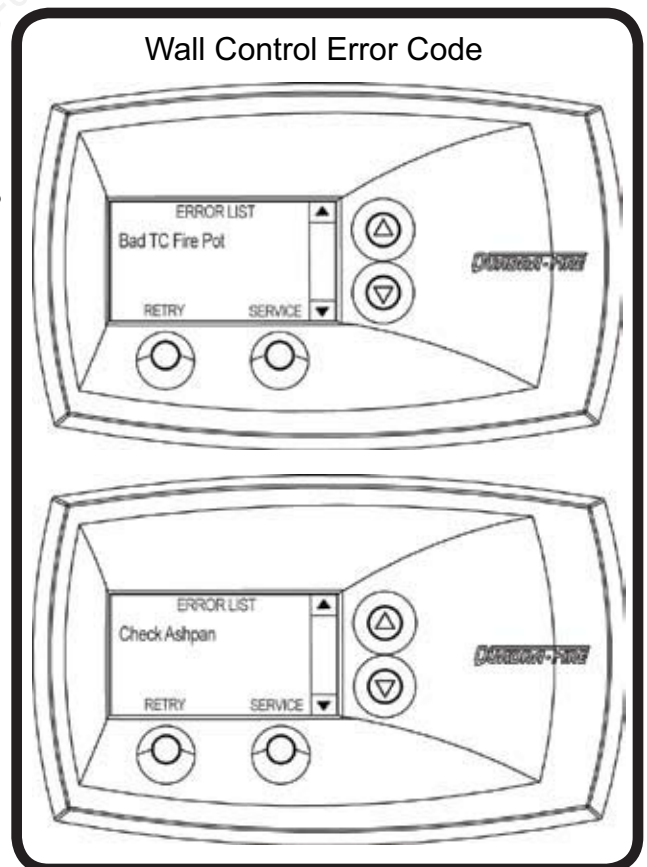

Symptoms of a faulty thermocouple:

- 1) Unit will not get out of start-up.
- 2) Unit is dumping raw fuel or dumping ashes into the into the ash pan while the fire is still going. **Note: The firepot thermocouple has to read under 550 degrees before it will allow an auto-clean.**
- 3) Unit is having a hard time burning Corn or is constantly over filling the firepot with fuel.

Firepot thermocouples are delicate and extra care must be taken when replacing them. Be careful to not over bend the “braided” part of the wire. If it is over bent, the wire can break or crack causing incorrect temperature readings or a “firepot thermocouple” error code.

If a unit is burning “Corn”, a crack in the thermocouple or a defective junction in the thermocouple can cause the unit to not burn the fuel correctly and will still not show a fault code.

TESTING THE THERMOCOUPLE FOR MILLIVOLTS:

- 1) Remove TC cover & heat the thermocouple tip with a lighter.
- 2) Disconnect the thermocouple from the board.
- 3) Use a digital meter and set it to millivolts DC.
- 4) Put each probe on the connector wires. A good thermocouple will read 15 mV or higher.

Specs: 30 mV = 1320 degrees

Max output: 50 mV DC

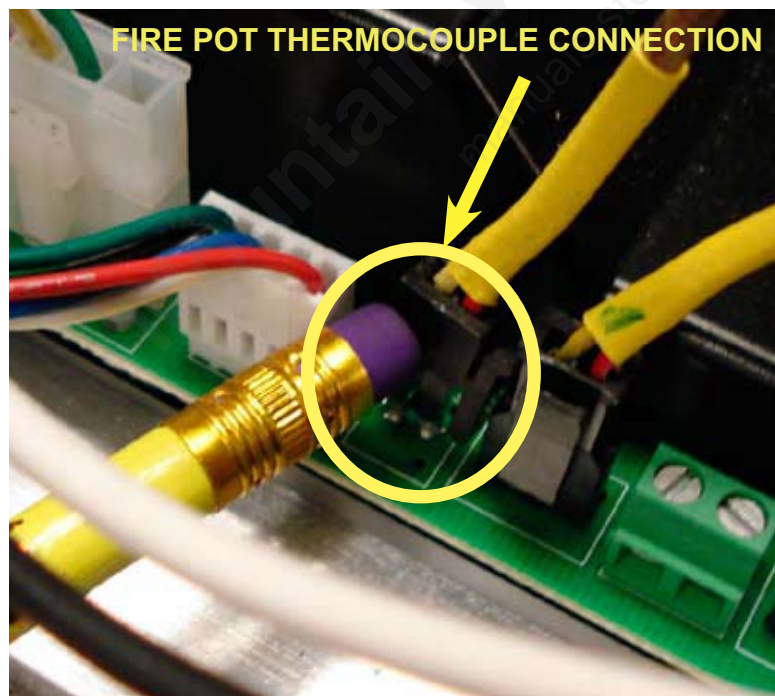
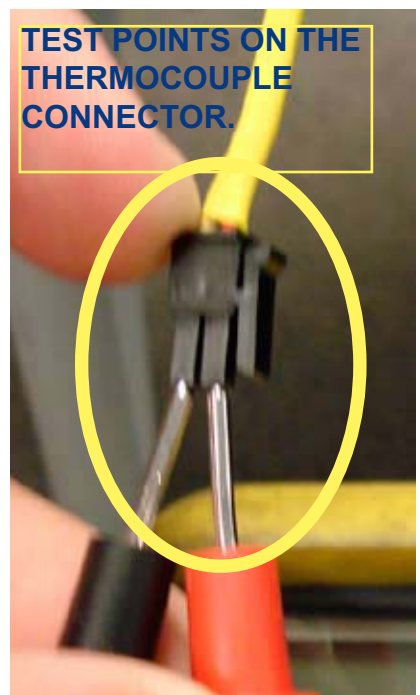

MT VERNON-AE TROUBLE SHOOTING MANUAL

IGNITER TROUBLE-SHOOTING

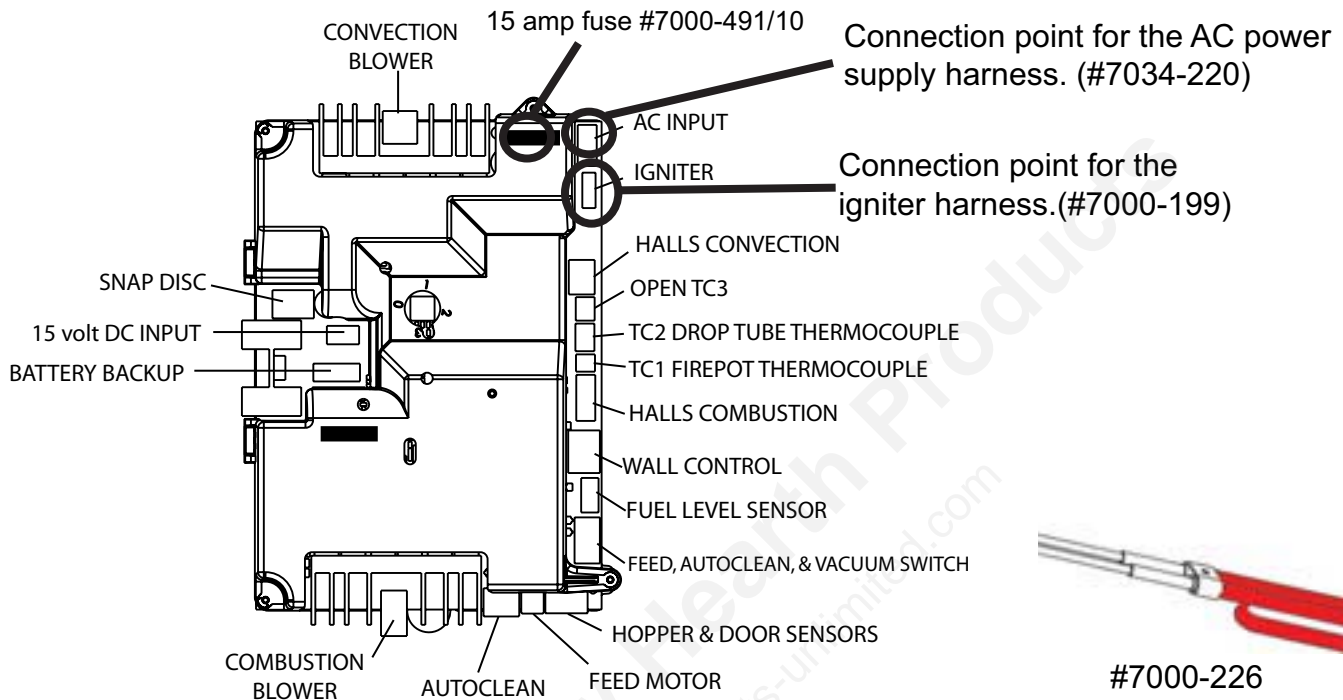

Items to check:

Check the igniter(#7000-226):

*Check for continuity in the igniter (should get around 36 ohms) or apply direct power to it. (This is an AC component)

Check the AC power supply harness (#7034-220):

*Check for power or a broken connection.

Check for power at the igniter harness (#7034-199):

*Make sure all connections are good.

*Check for continuity in the wire harness.

Check for power at the control board (SRV7000-456):

*Unplug the unit and restart. Make sure the wall control says "Startup".

*If power is not present, check the fuse or replace the control board.

UPDATE:

*Igniter chamber update communication was sent out on Sept. 18, 2007. This update will increase the service life of the igniter.

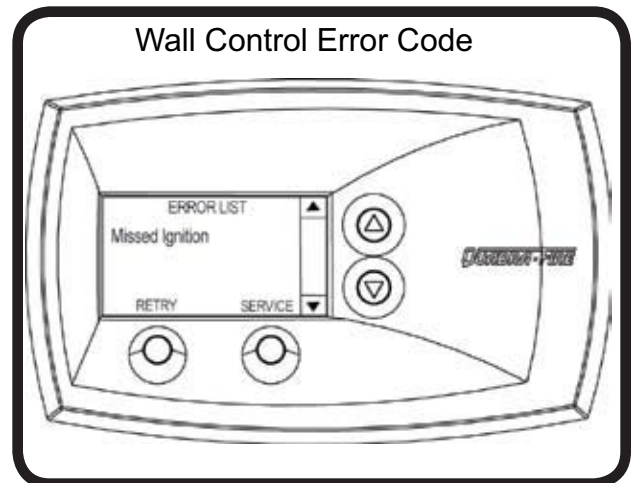

POWER SUPPLY TROUBLE-SHOOTING

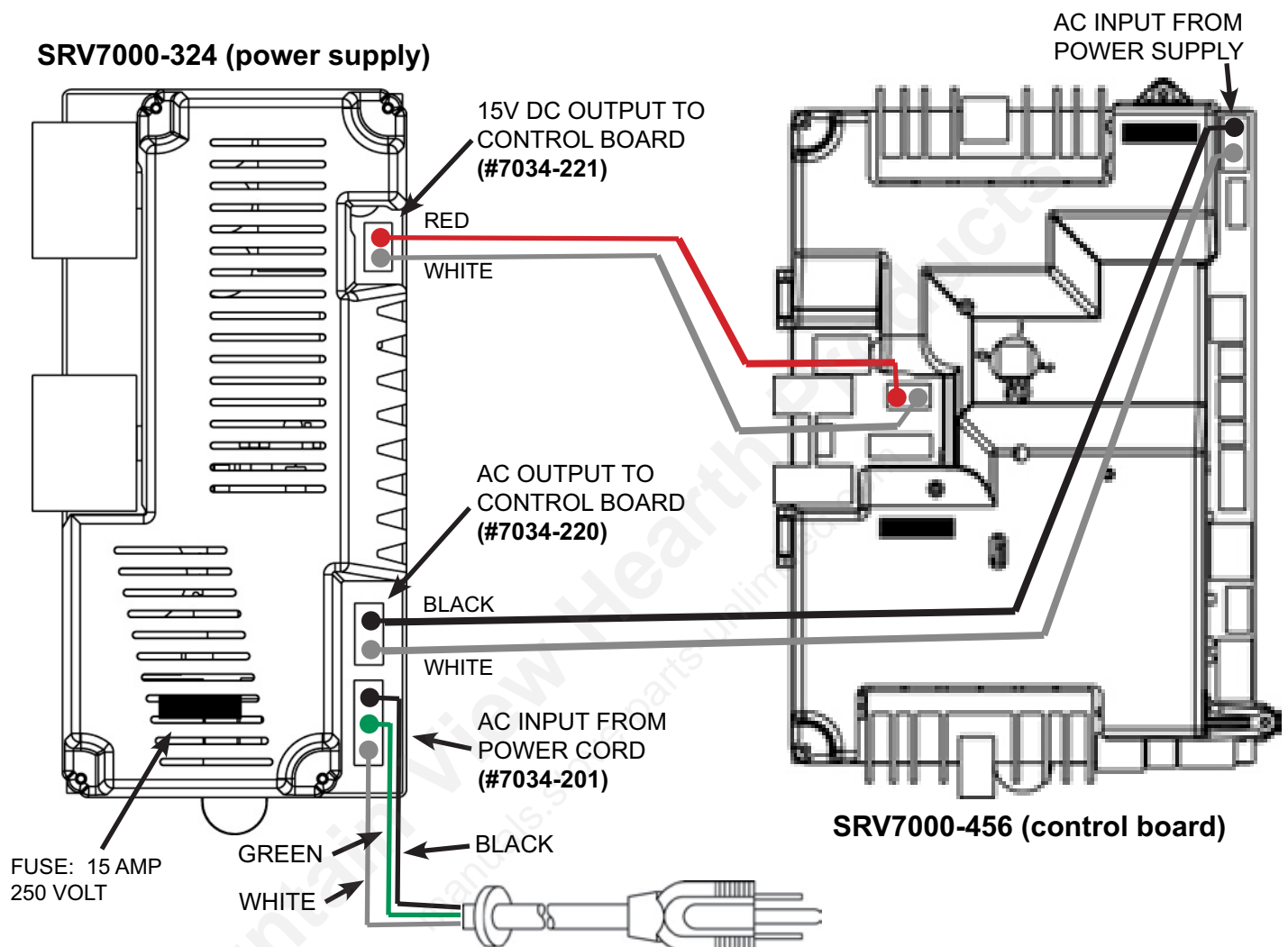

Items to check:

Check the AC power supply harness (#7034-201):

- *Check for power or a broken connection.

Check the DC power supply harness (#7034-221):

- *Check for a broken connection or for DC volts. (14 to 15 volts)
- *Check polarity. Make sure the wires are not backwards on the harness.
- *Replace the 15 amp fuse or power supply if there are not any volts.

If unit is making a “chirping” noise & wall control is blank:

- *Check the harness for a “short” in one of the wires.
- *Unplug wires from the control board until the noise goes away. Start with the door/hopper sensor harness first.

MT VERNON-AE TROUBLE SHOOTING MANUAL

DOOR/HOPPER/FUEL LEVEL SENSOR TROUBLE-SHOOTING



DOOR / HOPPER SENSOR (#7000-375)

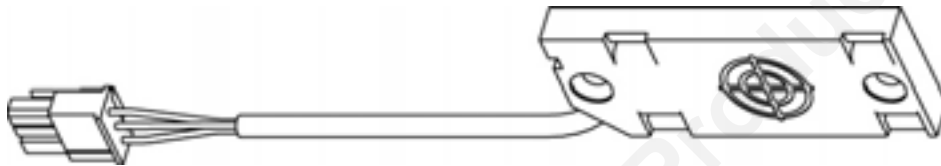

FUEL LEVEL SENSOR (#7000-380)

Items to check:

IF YOU GET THE “DOOR OPEN” ICON:

- *Check the front door. Make sure the latch is closed.
- *Check the sensor mount & magnet.
- *Check the connection to the control board.
- *Replace the sensor if previous checks are good.

IF YOU GET THE “HOPPER OPEN” ICON:

- *Check the hopper door. Make sure it is closed.
- *Check the sensor mount & magnet.
- *Check the connection to the control board.
- *Replace the sensor if previous checks are good.

IF YOU GET THE “FUEL LOW” ICON:

- *Check the fuel level in the hopper. Add fuel if low.
- *Check the sensor mount. Reposition sensor if needed.
- *Touch the sensor with your finger, if the yellow light doesn't come on, replace the sensor.

Wall Control Error Code

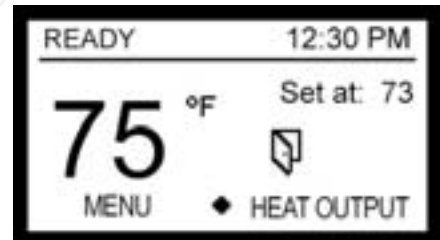

(DOOR OPEN)

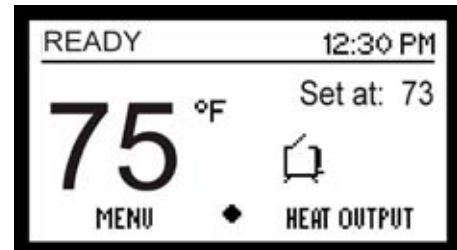

(HOPPER OPEN)

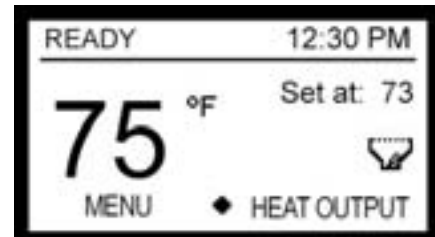

(FUEL LOW)

MT VERNON-AE TROUBLE SHOOTING MANUAL

WALL CONTROL TESTING

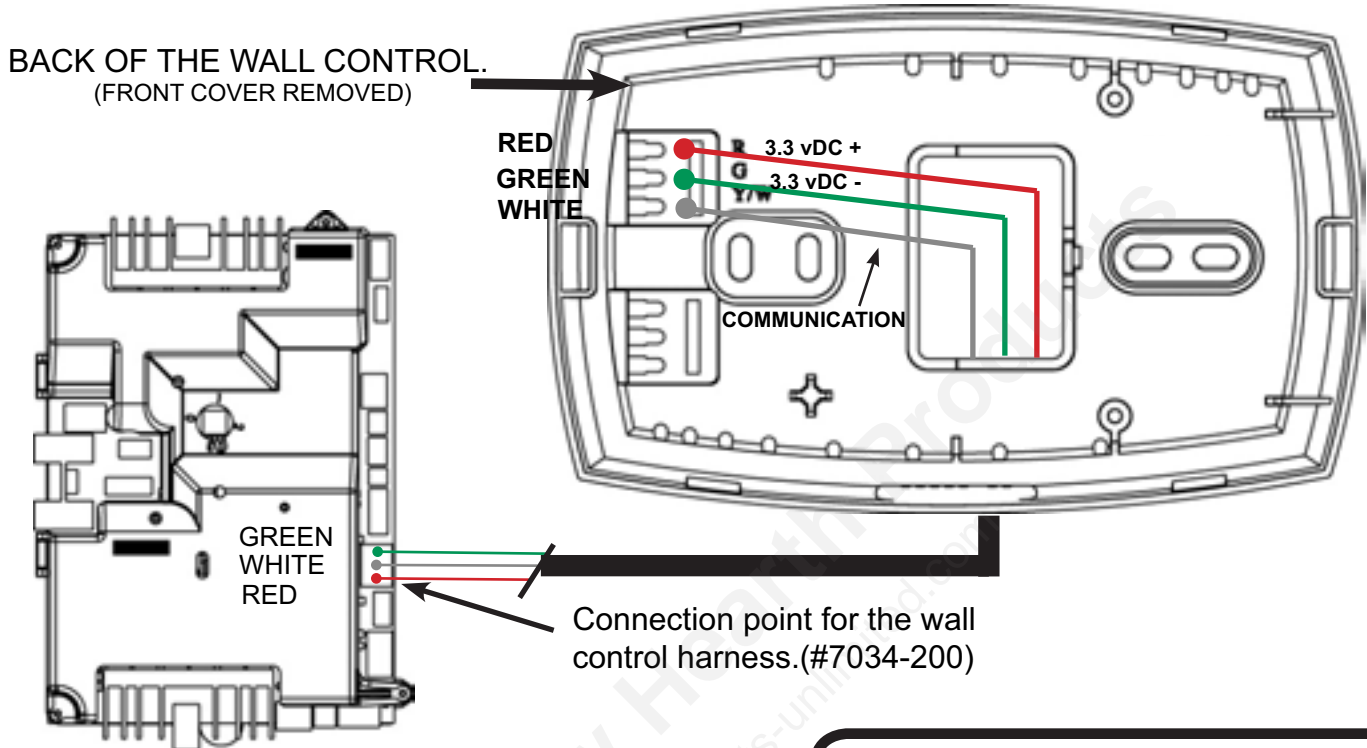

Items to check:

Check main power for the unit:

- *Check for power or a broken connection.
- *Check the power supply for 15 volts.

Check power going to the wall control (#7000-451):

- *Make sure thermostat wires are connected properly and match their appropriate color connection point.
- *Check for a broken wire or a staple in the t-stat wires.
- *The voltage on the green & red wire should be 3.3vDC
- *If voltage is present, replace the wall control.

Check the white wire if you get a “no communication” screen.

- *Check for a broken wire or bad connection.
- *If the wire & connections are good, replace the control board.

(SRV7000-456)

UPDATES:

7000-308

ECO 56774-- ADDED ABILITY TO UPLOAD FUEL TABLES.
(CODE 3.0) 3-21-07

7000-449

ECO 57823 -- RELEASED WITH 4.3 CODE. ADDED HIGH ELEVATION, CONV BLWR, PROPERTIES SCREENS. (7-11-07)

7000-451 -- RELEASED WITH 4.7 CODE. WILL WORK ON ALL CONTROL BOARDS. (8-8-07)

Wall Control Error Code

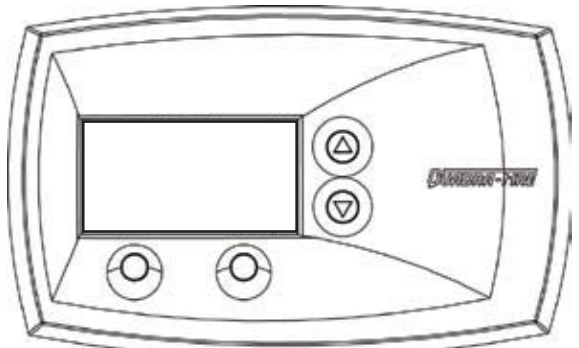

(NO COMMUNICATION)

MT VERNON-AE TROUBLE SHOOTING MANUAL

USB CORD OPERATION

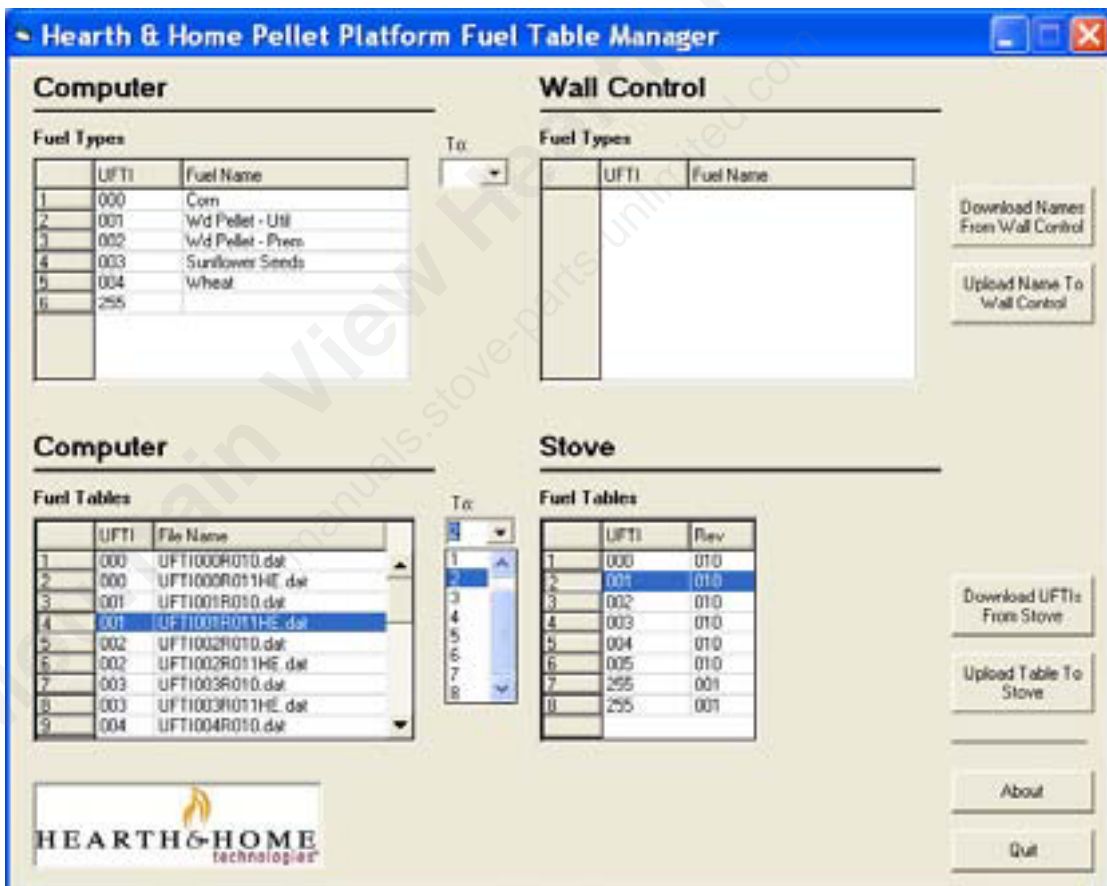
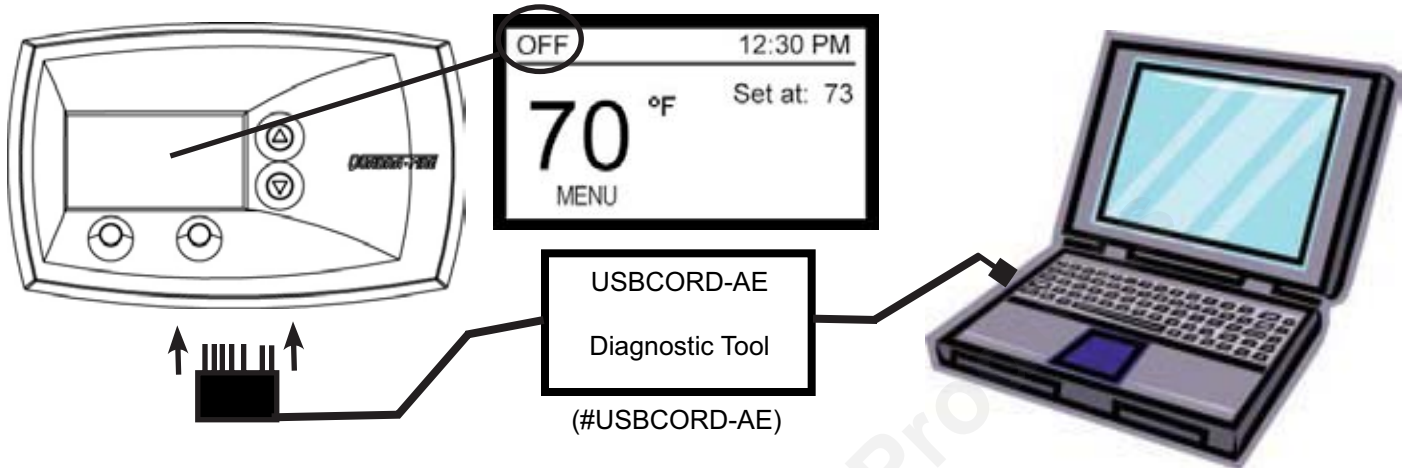

- 1) Make sure the wall control says "off" and all blowers are off.
- 2) Plug in USB cord to wall control and the computer.
- 3) Download the UFTI's from the stove.
- 4) Check for version of software and update as needed.
- 5) Visit www.quaddealer.com to access the latest fuel tables.

MT VERNON-AE TROUBLE SHOOTING MANUAL

CAUTION

The appliance must be in complete shutdown, completely cool and the exhaust blower off before performing any cleaning or maintenance. There is a risk of shock if the appliance is not unplugged before servicing the appliance.

PROPER SHUTDOWN PROCEDURE

1. Set the wall control thermostat to "OFF" on AUTOMATIC/MANUAL SETTING screen and let the appliance completely cool. The exhaust blower must be off before you can unplug the appliance before servicing.
2. Smoke spillage into the room can occur if the appliance is not cool before unplugging.

NOTE: Performing this routine service will require approximately 20 minutes a month depending on type and quality of fuel you burn.

CLEANING OR INSPECTION	FREQUENCY		DAILY	WEEKLY	Bi-WEEKLY	YEARLY
FIREPOT Softwood Pellets	Every 5 bags	-OR-		X		
FIREPOT Hardwood Pellets	Every 3 bags	-OR-		X		
FIREPOT Corn, Wheat, or Sunflower Seeds	Every 1 bag	-OR-	X			
ASHPAN Wood Pellets	Every 5 bags	-OR-		X		
ASHPAN Alternate Fuel	Daily	-OR-	X			
HEAT EXCHANGER	Every 1 ton of fuel	-OR-			X	
EXHAUST BLOWER	Every 3 tons of fuel	-OR-				X

FIREPOT MAINTENANCE

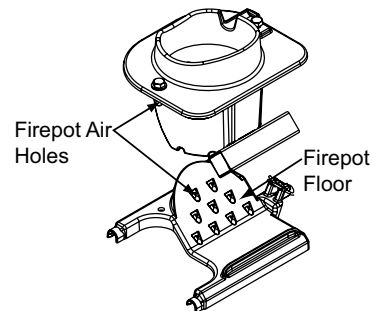
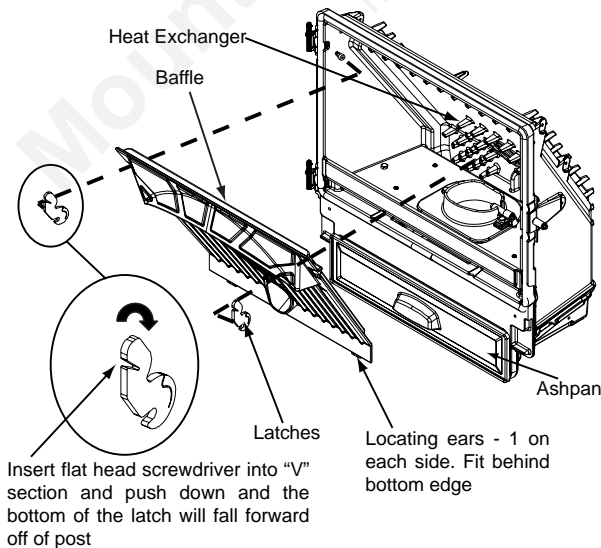

Firepot Exploded View

The firepot floor and firepot air holes will need to be scraped occasionally depending on the quality of fuel being used. Use a putty knife, a flat head screwdriver or the firepot clean-out tool provided to remove excess carbon from the firepot.

MT VERNON-AE TROUBLE SHOOTING MANUAL

CLEANING & MAINTENANCE

Tools Needed: Shop Vac* and Micro Cleaning Kit*; flat head and Phillips screwdriver; 11/32 Nut-driver or wrench.



* Shop Vac and Micro Cleaning Kit

can be purchased at your local hardware store.

1. It is necessary to remove the baffle to gain access to the heat exchanger. Complete instructions for removing the baffle can be found in your Owner's Manual.
2. Vacuum the ash from the heat exchanger with an upholstery brush to remove the majority of the ash. Be sure to vacuum the back of the baffle also. Inspect the drop tube and remove any residue build-up in the drop tube. **Figure 2.**



Figure 1 - Example of a dirty heat exchanger



Figure 2

3. Assemble the crevice tool from the Micro Cleaning Kit to attach to a Shop Vac. **Figure 3.**



Figure 3

4. Use the crevice tool to finish cleaning the heat exchanger fins. It is critical that the 2 exhaust exits the back of the firebox floor (left and right) be thoroughly cleaned. **Figure 4.** There are several ways this can done.
 - a. Use the crevice tool.
 - b. Attach a hose 1/2 inch (12.7mm) in diameter and approximately 2 feet (607mm) in length to your vacuum hose.
 - c. Use a bottle brush and push the ash down to the bottom. Remove the combustion (exhaust) blower and then vacuum out the ash. **Figures 5-8 on page 4.**

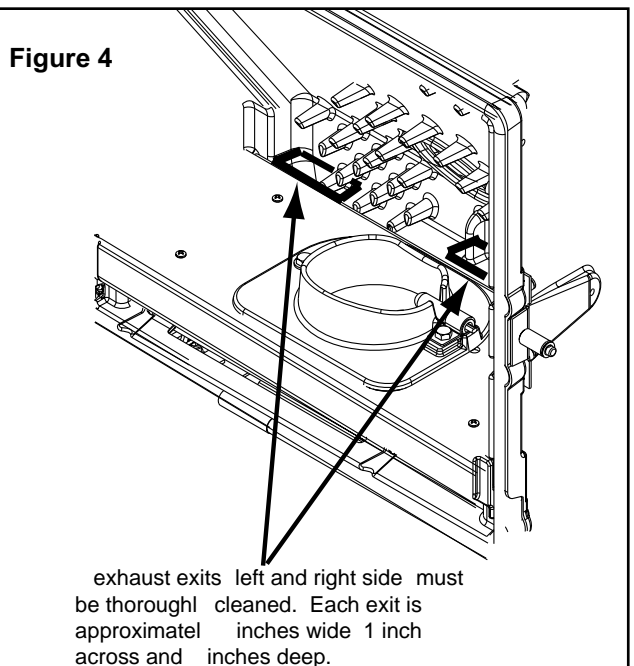

MT VERNON-AE TROUBLE SHOOTING MANUAL

5. Removing the Combustion (Exhaust) Blower

- The combustion blower is mounted in the bottom right rear of the appliance. **Figure 5.**
- Use an 11/32 nut driver to loosen all six nuts, but do not remove. Rotate the blower and remove from the housing. **Figure 6.**
- Set the blower on the top of the housing for the stove and place on the firebox floor for the insert. You do not need to disconnect the wires. **Figure 7.**
- Vacuum out the exhaust area. **Figure 8.**
- A view of the inside of the exhaust area. **Figure 9.**



Figure 6



Figure 7 - Stove is shown in this example

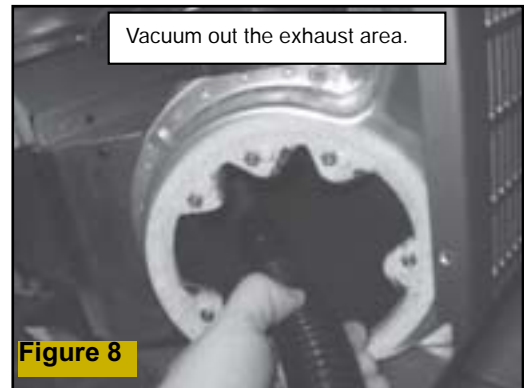
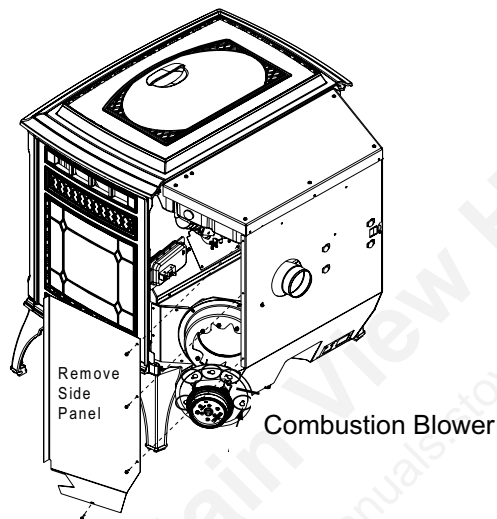

Figure 8



Figure 9

BLOWER LOCATION ON STOVE



BLOWER LOCATION ON INSERT

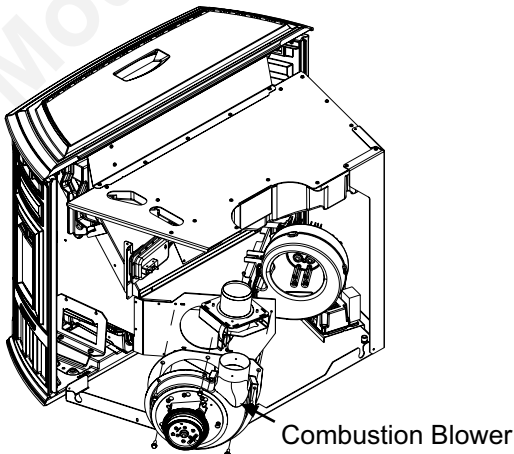

Figure 5

MT VERNON-AE TROUBLE SHOOTING MANUAL

PARTS LIST

(REFER TO EXPLODED VIEW FOR PART LOCATION)

REPLACEMENT PARTS:

AIR INTAKE SHIELD.....7034-224
BAFFLE:.....(28) 7034-148

BLOWERS:

CONVECTION (180cfm).....(17) 7000-260
EXHAUST.....(21) 7034-033

CAST PARTS: (add mbk,pmh,csb,cwl to part # for color)

See exploded view

COMPONENT PACKS (FS & I):

MATTE BLACK (FS).....7034-034
MAHOGANY (FS).....7034-037
SIENNA BRONZE (FS).....7034-035
WILLOW (FS).....7034-036

MATTE BLACK (Insert).....7036-018
MAHOGANY (Insert).....7036-021
SIENNA BRONZE (Insert).....7036-019
WILLOW (Insert).....7036-020

CONTROL BOARD........(20) SRV7000-456

DOOR / ASHPAN PARTS:

ASHPAN ASSY.....(25) 7034-013
GASKET FOR ASHPAN (3/4").....(24) 7034-178
GASKET FOR DOOR (3/4").....(23) 7034-177
GASKET, GLASS.....7000-377/10
GLASS ASSY w/Gasket.....(26) 7034-007
GLASS SIDE ASSY (1pc, insert only)...(27) 414-5380
LATCH FOR ASHPAN (roller style).....7000-494

FEED MOTOR, DC........(14) 7000-313

FEED ASSEMBLY.....(13) 7034-004

FIREPOT PARTS:

AUTOCLEAN MOTOR.....7034-020
FIREPOT RISER CLAMP.....7034-012
FIREPOT (BOTTOM SLIDE PART).....7034-153
FIREPOT (TOP PART).....7034-010
IGNITER, HEATING ELEMENT.....7000-226

GASKETS:

CONVECTION.....(18) 7000-329
EXHAUST BLOWER TRANSITION.....7000-332
EXHAUST (ROUND WHITE).....7000-423
FEED MOTOR GASKET.....7034-144
FIREPOT GASKET.....7034-190

LOG SET.....LOGS-60-AE

OUTSIDE AIR KIT.....OAK-3

POWER CORD (120V).....812-1180

POWER CORD (12V BATTERY).....12VCORD-AE

POWER SUPPLY.....(19) SRV7000-324

T-COUPLE COVER.....7034-186

THERMOCOUPLE (FIREPOT).....7000-334

THERMOCOUPLE (DROP TUBE).....7000-381

T-STAT BLOCK.....SRV7034-200

VACUUM SWITCH.....(22) 7000-166

VACUUM HOSE.....7000-373

WALL CONTROL.....7000-451

WIRE HARNESS & SENSOR PARTS:

AUTOCLEAN MICRO-SWITCH.....7000-327
FEED MOTOR OPTICAL SENSOR.....7034-038
FUEL LEVEL SENSOR.....7000-380
MAGNETIC SWITCH (HOPPER/DOOR).....(16) 7000-375
OVERHEAT SENSOR (SNAP DISC).....(15) 230-1290
THERMOSTAT WIRE 3 COND.....7000-409

HARNESS (AUTOCLEAN, AUGER, VAC SWITCH, 10-PIN CONNECTOR).....SRV7034-191

HARNESS (BATTERY BACK-UP).....7034-202

HARNESS (CONVECTION BLOWER).....7034-219

HARNESS (DOOR/HOPPER SENSORS).....7034-192

HARNESS (IGNITER).....7034-199

HARNESS (OVERHEAT SENSOR).....7034-193

HARNESS (POWER OUT A/C).....7034-220

HARNESS (POWER OUT D/C).....7034-221

HARNESS (PWR CORD TO PWR SUPPLY).....7034-201

HARNESS (T-STAT/WALL CONTROL).....7034-200

MT VERNON-AE TROUBLE SHOOTING MANUAL

MT VERNON-AE INSERT

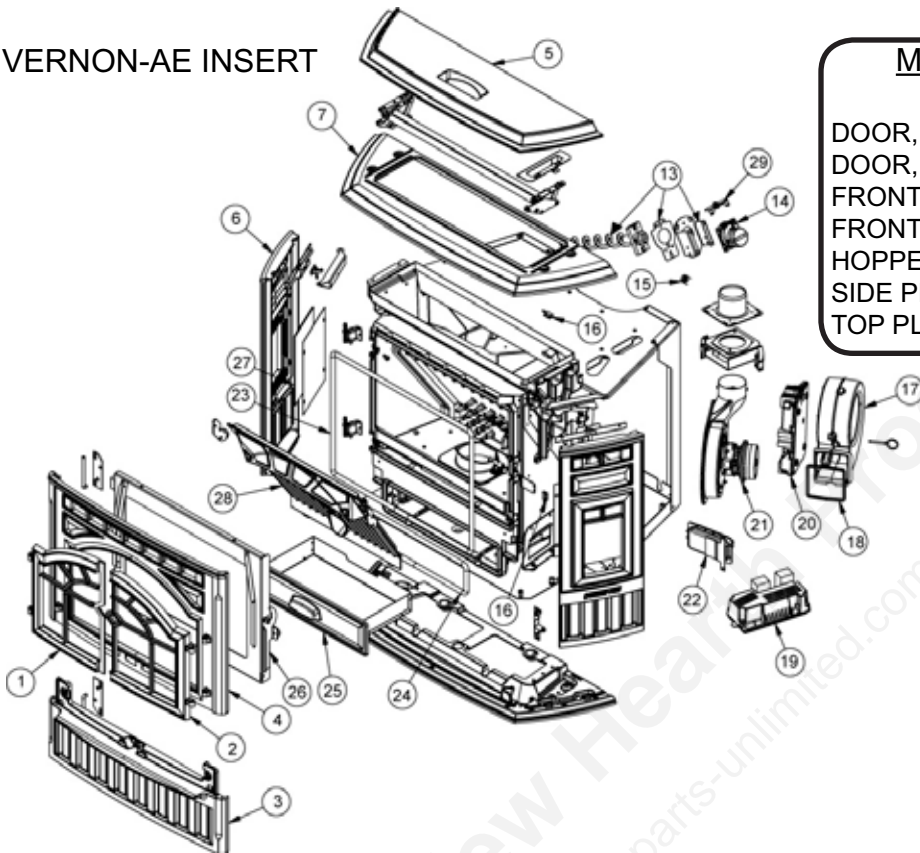

MT VERNON-AE-I CAST PARTS

- DOOR, LEFT.....(1) 7005-110
- DOOR, RIGHT.....(2) 7005-109
- FRONT, LOWER....(3) 7036-122
- FRONT, UPPER....(4) 7036-105
- HOPPER LID.....(5) 7036-107
- SIDE PLATE.....(6) 7036-103
- TOP PLATE.....(7) 7036-101

MT VERNON-AE CAST PARTS

- ASHLIP.....(8) 7005-111
- FRONT PLATE....(9) 7005-108
- DOOR, LEFT.....(1) 7005-110
- DOOR, RIGHT....(2) 7005-109
- HOPPER LID.....(10) 7034-157
- SIDE PLATE.....(11) 7005-107
- TOP PLATE.....(12) 7034-155

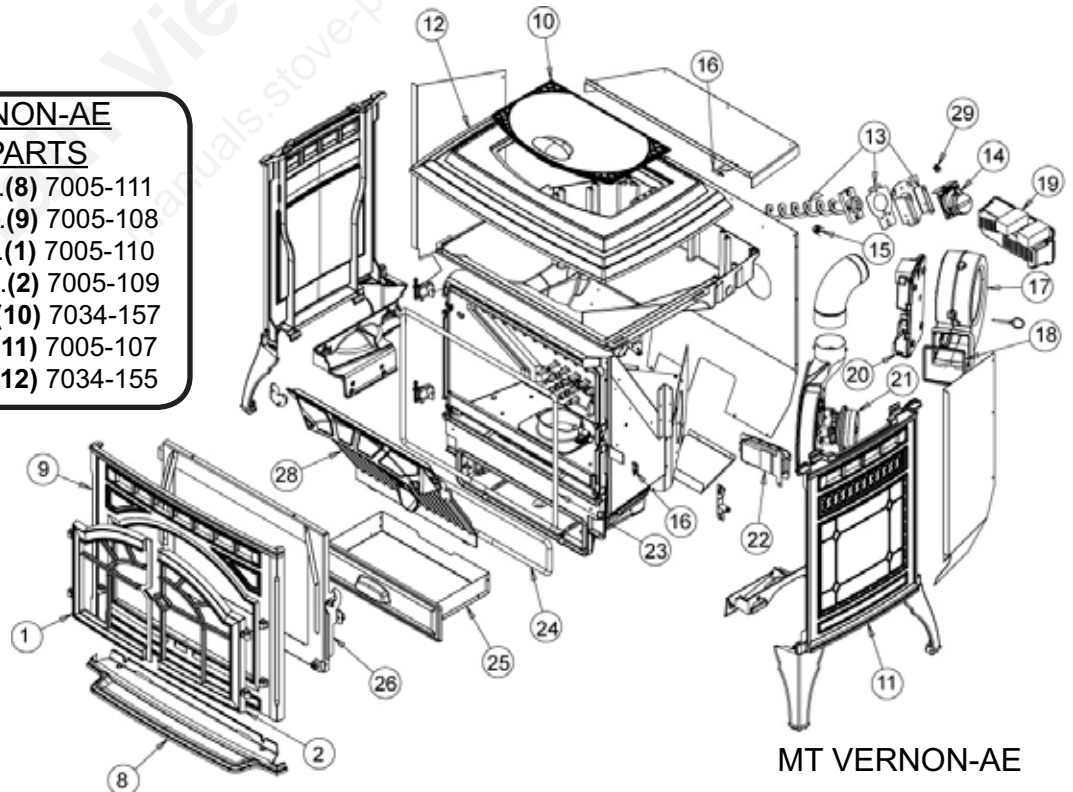

MT VERNON-AE

MT VERNON-AE TROUBLE SHOOTING MANUAL

Mountain View Hearth Products
manuals.stove-parts-unlimited.com