



Afton Bay Operation & Maintenance Manual

Table of Contents

ST. CROIX FEATURES	2
INSTALLATION	3
PREVENTING CHIMNEY FIRES	3
SATISFACTORY PERFORMANCE	3
APPROVED FUELS	3
Pellets, Cherry Pits & Pellet /Corn mix	3
OPERATING INSTRUCTIONS	4
Control Board Features.....	5
Thermostat Function – How does it work?	6
Pre-Lighting Instructions.....	7
Lighting Your Stove	8
Shutting the Stove off	9
Diagnostic Features.....	9
Safety Features	10
Combustion Air Damper	11
Flame Pattern Characteristics	11
MAINTAINING THE STOVE	12
Daily Maintenance	13-14
Periodic Maintenance	14-15
Yearly Maintenance	16-17
SAFE OPERATION	18
TROUBLESHOOTING AND FAQ	19-23
PARTS LAYOUT	24-27
WARRANTY	28

"Please read this entire manual before installation and use of this pellet fuel-burning room heater. Failure to follow these instructions could result in property damage, bodily injury or even death."

"Contact local building or fire officials about restrictions and installation inspection requirements in your area."

Save these Instructions

1013

Dear St. Croix Wood Pellet Stove Owner:

Congratulations! Your purchase of a St. Croix wood pellet stove places you among a select group of individuals who have demonstrated their concern about residential heating efficiency and our environment.

This owner's manual is designed to help you obtain maximum benefit from your St. Croix wood pellet stove.

Please read this manual in its entirety **BEFORE** operating your pellet stove. During the manufacturing process every effort has been expended to ensure that each St. Croix wood pellet stove meets the highest quality standards of material and workmanship.

Here are some important aspects of wood pellet stove installation and operation which you must observe in order to obtain maximum comfort and safety from your new St. Croix wood pellet stove.

1. Have your new St. Croix wood pellet stove installed by trained, qualified personnel.
2. Use only clean, dry quality wood pellets that are known to burn satisfactorily in your stove.
3. Faithfully adhere to the maintenance program described in this manual. Thank you for selecting a St. Croix wood pellet stove as the environmentally preferred answer to your residential heating needs.

Afton Bay

SAVE THIS OPERATIONS AND
MAINTENANCE MANUAL

LARGE 65 LBS. HOPPER

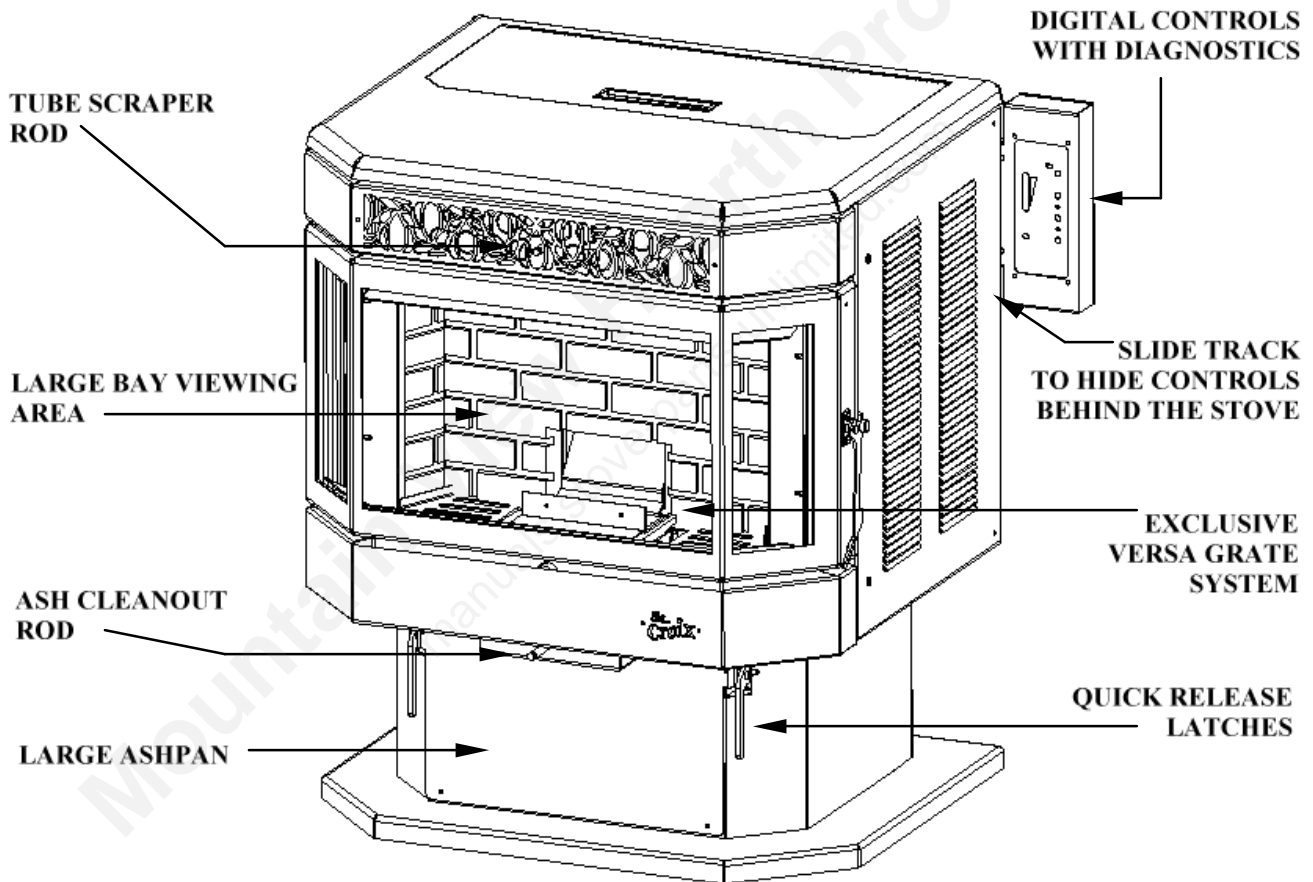

Figure 1

Operation and Maintenance

Afton Bay Wood Pellet Stove

CAUTION: Operate this unit only with the fuel hopper lid closed. Failure to do so may result in emission of products of combustion from the hopper under certain conditions. Maintain hopper seal in good condition

INSTALLATION

Proper installation is essential for safety, effective operation, warranty coverage, insurance requirements and to meet local building codes. Installation requirements are described in the Installation Manual included with your new stove.

PREVENTING CHIMNEY FIRES

Chimney fires can be prevented by properly operating the stove and by periodic inspection and cleaning of the chimney. When wood is burned it produces tar and other organic vapors, which combine with expelled moisture to form creosote. The creosote vapors condense in the relatively cool chimney flue associated with a slow burning fire. As a result, creosote residue accumulates on the flue lining and when ignited this creosote can result in an extremely hot chimney fire.

The chimney and chimney connector should be inspected at least once every two months during the heating season to determine if a creosote build-up has occurred. If a significant layer of creosote has accumulated (3 mm or more) it should be removed to reduce the risk of a chimney fire. Use of an appropriately sized chimney brush or the services of a professional chimney sweep are recommended.

SATISFACTORY PERFORMANCE

The keys to satisfactory performance are: proper operation of the stove, diligent maintenance and burning only dry, clean, quality fuel. Clinkers and ash are a by-product of combustion and are not caused solely by your stove. Stove performance can be quickly and severely reduced if poor quality pellets are used.

APPROVED FUELS

PELLETS - Pellets with excessive sawdust should be screened by sifting with 1/4" mesh screening. Store Pellets under cover on a wooden pallet or other methods to ensure they do not become rain soaked or absorb moisture from damp or wet floors. Do not store pellets within stove installation clearances or within the space required for ash removal. *The stove is not warranted against damage caused by poor pellets, incorrect operation, poor maintenance or incorrect installation.* **NOTE: Contact your dealer for more information on APFI approved wood pellet fuels.**

CHERRY PITS - Cherry Pits will burn much in the same manner as pellets. They will have higher ash content than Premium Pellets. Adjust your maintenance schedule accordingly. *No standards exist for cherry pits as a fuel. Inspect fuel before purchasing. The stove is not warranted against damage caused by poor cherry pits, incorrect operation, poor maintenance or incorrect installation.*

ADDING CORN TO THE MIX - The Afton Bay is approved to burn a mixture of pellets and corn (maximum 50% corn). The Thermostat Switch should be set to the Manual position. (See Fig. 2 on page 5) Operation of the stove doesn't change when burning a mixture of pellets and corn. The burn pot will need to be cleaned on a daily basis, using the "Pot Scraper Tool" shown in figure 6 on page 12. Use the Pot Scraper Tool to remove any clinkers that build up because of the corn when needed. For more information, read the Daily, Periodic and Yearly Maintenance section towards the back of this manual.

OPERATING INSTRUCTIONS

A different type of heater. The pellet stove is neither a cord wood stove nor a furnace. Its operation and maintenance differ from the traditional wood stove. FOLLOW THESE OPERATING INSTRUCTIONS EXACTLY AS STATED TO ENSURE SAFE AND RELIABLE OPERATION.

1. Carefully read this "Operation and Maintenance" manual in its entirety BEFORE lighting your stove for the first time.
2. Obtain final inspection and approval of installation from local building officials.
3. Carefully clean all marks off the gold plated parts before the first fire is lighted. Use a soft cloth and a "Windex" type cleaner. **Caution:** Never use an abrasive cleaner on any plated or painted parts of the stove.
4. Have your dealer demonstrate all the operational and maintenance steps necessary for proper use of the stove. Sign and return the warranty card, to the address listed on the last page.
5. Some odors may be given off during the first few hours of burning during initial break-in. These odors are normal and not harmful. However, ventilating the room until the odors disappear is recommended.
6. The stove will become HOT while in operation. Keep children, clothing and furniture away from all stove surfaces. **WARNING: Direct contact with the stove while operating may cause skin burns.**
7. To avoid the possibility of smoke and/or sparks entering the room always keep firebox and ash pan doors closed whenever the stove is operating.
8. A certain amount of carbon monoxide may be produced within the stove as a by-product of combustion. All exhaust vent connections must be sealed with RTV silicone to assure a gas tight seal. Any leaks into a confined area caused by faulty installation or improper operation of the stove could produce dizziness, nausea and in extreme cases, death.
9. An outside source of combustion air is required on all mobile home installations. If room air is used to supply combustion air, room air starvation, operation of exhaust fans and icing of air vents can adversely affect proper stove operation. If these conditions exist, outside air should be used.
10. Smoke detectors, installed in the same general area as the stove, may be activated if the stove door is left open and smoke is allowed to enter the area.

Control Board Features

The Control Board controls all functions of the Afton Bay by monitoring sensors that are in the system. These sensors serve 2 purposes.

- a. General Operation of the Stove.
- b. Safety Features, to shut the unit down in the event the sensors detect a problem in the unit.

The Control Board also has Diagnostic Capabilities to help in diagnosing 3 areas in the Stove. These areas are:

1. High Temperature Limit.
2. Proof of Fire Sensor
3. Vacuum in the Firebox

A closer look at the Control Board to the right in figure 2 will explain how the board works. There are essentially 4 buttons on the control board. Two of these buttons, the **Heat Level** and **Trim** Buttons, have a High/Low side to advance these settings up or down. There is a **Slide Switch** that controls the Thermostat Mode and an **LED Light** bar that indicates which of the 5 Heat Settings the Afton Bay is running on.

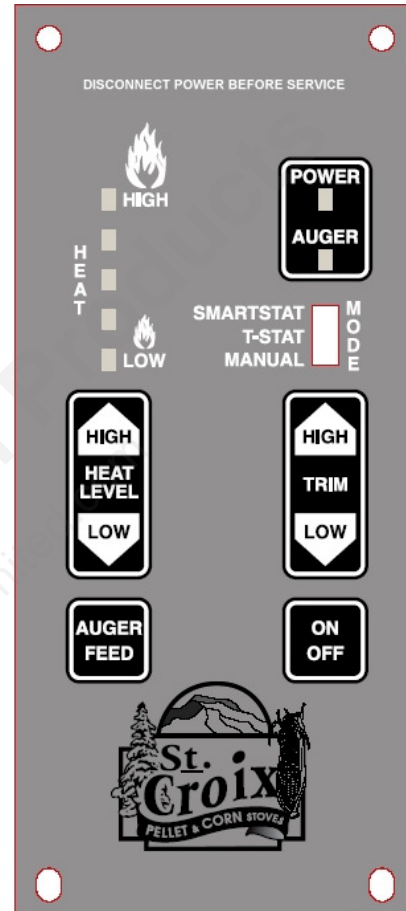

Figure 2

The LED Light bar is also used during the Diagnostic process, see page 9 for more details

1. The On/Off button not only turns the Afton Bay On and Off, *it also resets the board if one of the sensors has detected a problem and the board is flashing a Diagnostic code.*
2. The Auger Feed button will allow the user to manually auger fuel into the burn pot on start up when needed. This is particularly helpful in priming the Auger Tube when it is empty (After the hopper has run out of pellets). This button is also used to make small adjustments to the combustion air and the feed rates as part of the **Fine Tuning** process of the control board.

3. The Heat Level button will advance the setting up and down between level 1 and 5. It will also be used in the Fine Tuning process of the feed rates if needed.

To adjust the Feed-rates:

Hold the Auger Feed Button down and press the Heat Level High/Low button and this will change the ON Time up or down .25 seconds from the factory setting. Watch the LED lights to see the setting is on (it will flash the new setting). This new setting will stay in memory from this point on. The LED lights indicate the level of adjustment and the factory setting is the center LED light. This gives two .25 second adjustments up and two .25 second adjustments down.

4. The Trim button is used to adjust the Exhaust (Combustion) fan voltages up or down to provide for **fine-tuning** of the combustion air. The LED lights indicate the level of adjustment and the factory setting is the center LED light. This gives 2 adjustments up and 2 adjustments down.

To adjust the Combustion Fan voltages:

Hold the Auger Feed button down and press the Trim High/Low button and this will change the fan voltage approximately 2.5 volts up or down from the factory setting. Watch the LED lights to see the setting is on (it will flash the new setting). This new setting will stay in memory from this point on. **Use these adjustments in conjunction with the damper.**

5. The Thermostat Slide switch allows the Stove to be run in 3 different Modes:

a. **Manual Mode** - The Control Board controls all functions of the Ashby.

b. **T-Stat Mode.** *The Stove is Fully-Automatic in the T-Stat Mode. (T-Stat requires the stove be turned on at the control board the first time).* The unit is hooked to a Thermostat and when calling for heat the unit will advance to the Heat level set at the Control board. Once the Heat demand has been met, the Stove will immediately shut down. Use this setting when heating a small area or when Temperatures are Moderate. *Not recommended for use with a mixture of Pellets and Corn.*

c. **SmartStat Mode** - *Can only be used with Pellets & Cherry Pits in the Afton Bay. Not recommended for use with a mixture of Pellets and Corn.* The unit is hooked to a Thermostat and when calling for heat the Stove will advance to the Heat level set at the Control board. Once the Heat demand has been met the Stove will drop to the #1 Heat Level setting **and pilot for one hour**. If the Thermostat does not call for heat during that hour the unit shuts off. It will **re-light itself the next time the Thermostat calls for heat**. This setting is best used during early fall or late spring when constant heat is not needed.

6. **Cleaning Cycle.** The Afton Bay only uses Programs 3 & 4. This allows the Afton Bay to operate in an Automatic mode using the Igniter. These 2 programs have a Cleaning Cycle built into them that allows the unit to drop to the #1 level for 5 minutes on timed intervals. During the cleaning cycle the Combustion Fan will run at line voltage to blow excess ash from the burn pot. This feature only functions if the unit is operating on levels 3 through 5. **The ON/OFF light blinks during this cycle.**

Pre-Lighting Instructions

WARNING: - Risk of Fire.

- Do not operate with the Firebox door or Ash Removal doors open
- Do not store Fuel or other Combustible material within Installation Clearances.
- Inspect and Clean Flues and Chimneys regularly.

Danger: Risk of Fire or Explosion

- Do not burn Garbage, Gasoline, Drain Oil or other Flammable Liquids.

WARNING: The auger can start at any time while the Ashby is running

REMEMBER: Read the manual before lighting the unit.

The Control Board has 4 separate programs. Each program is specific to a certain fuel. Before lighting the Stove for the first time, be sure the correct program is chosen.

To change the program on the board, the Stove must be off and the unit must be cold. The programs are identical in operation, except for the Cycle Time. The Cycle time is the total of the ON Time & OFF Time added together. The ON Times are constant, so this means that the OFF Time is increased or decreased, depending on the program chosen.

1 - **Program 1.** The Cycle Time is 11.5 seconds. **THIS PROGRAM IS ONLY TO BE USED WITH OUR GRAIN BURNING MODELS. (DO NOT USE THIS PROGRAM WITH THE AFTON BAY).**

2 - **Program 2.** The Cycle Time is 13 seconds. **THIS PROGRAM IS ONLY TO BE USED WITH OUR GRAIN BURNING MODELS. (DO NOT USE THIS PROGRAM WITH THE AFTON BAY).**

3 - **Program 3.** The Cycle Time is 11.5 seconds. **THIS PROGRAM IS THE DEFAULT PROGRAM FOR USE WITH THE AFTON BAY.** This program is for use with **Pellets, Cherry Pits and a 50/50 Percent Mixture of Pellets and Corn (See fig. 3 on page 8).** **(DO NOT USE THIS PROGRAM WITH OUR GRAIN BURNING MODELS).**

4 - **Program 4.** The Cycle Time is 10 seconds. **THIS PROGRAM IS ONLY FOR USE WITH THE CHERRY PITS. (See fig. 3 on page 8).** **(DO NOT USE THIS PROGRAM WITH OUR GRAIN BURNING MODELS).**

If the *incorrect* program is chosen for a specific fuel, the burnpot will overload. Use caution when using this feature. *The default program to use for the Afton Bay is Program 3.* Program 4 is for Cherry Pits and in some instances may be used to “Tweak” the unit for certain qualities of fuel and installation conditions. *(Ask Dealer before using program 4 for any other fuel than Cherry Pits.)*

Changing the program on the Control Board

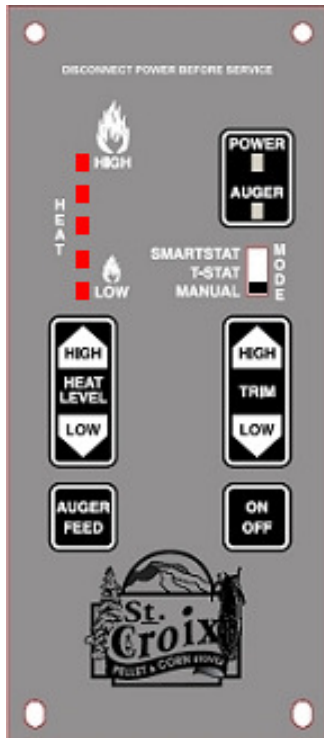

Figure 3

To change the Program the Stove must be in the OFF position, the unit must be completely cooled down so the Proof of Fire Switch is Open and the Thermostat slide switch must be in the Manual mode. (See figure 3)

Press & hold the Auger Feed Button, then press the Trim **High & Low** Button at the same time. The LED lights that indicate the heat level will flash. The number of times the lights Flash will indicate which program is running.

Program 1 – LED lights flash *once*

Program 2 – LED lights flash *twice*

Program 3 –LED lights flash *three times*

Program 4 – LED lights flash *four times*

Lighting the Afton Bay with the Versa Grate System. (Program 3 & 4)

1. Make sure there are pellets in the hopper and the viewing door and ash pan door are closed.
2. Push the On/Off button on the control board. (See figure 3)

At this point all that needs to be done is to monitor the burn pot to make sure the stove starts up properly. Once the On/Off button has been pushed the Start Up program takes over.

The Start up Program works as follows:

- a. The Combustion fan and Room fan come on at high speed and the control board checks to make sure the Vacuum switch locks in. (See Diagnostic features on page 9 and 10)
- b. When the board senses the Vacuum switch the Combustion fan drops to the #1 setting and the Room fan shuts off.
- c. The Igniter and the Auger come on (the Auger runs for 2 minutes). The stove will typically light in the first 3 - 4 minutes. After 5 minutes the board checks for “Proof of Fire” and starts feeding pellets on the #1 setting. Once the board senses P.O.F. the Igniter shuts off and the stove has started successfully.

- d. If the board fails to sense P.O.F. it will repeat the previous step and continue feeding pellets on the #1 setting for 5 more minutes.
- e. The board will check for P.O.F. one more time. If the board still fails to sense the Proof of Fire switch, the stove will go into “Safety shutdown” (See Diagnostic Features on page 9 and 10)

If the stove fails to start, repeat steps listed above.

CAUTION: NEVER ADD FIRE STARTER TO A HOT STOVE.

Shutting the Unit Off

1. Press the On/Off switch once; the lights will go off and the fire will go out in a few minutes. The board essentially goes into “Safety shutdown”.
1. As long as the temperature within the Stove remains above 110°F the Fans will continue to run. When the P.O.F. switch drops out, the room fan shuts off and the Combustion fan will run for another 10 minutes and finally shut down completely.
2. NEVER unplug the Stove to shut it off. Doing so may cause a significant amount of smoke to enter the room.

Diagnostic Features of the Control Board

The #2 LED, #3 LED and #4 LED lights on the LED Light bar) will flash to give a diagnostic code to help in diagnosing problems that may occur. *(Read Frequently Asked Questions for more information)*

These conditions fall into 2 categories:

- a. Heat related issues.
- b. Vacuum related issues.

The Diagnostic Lights flash as follows:

1. The **Proof of Fire** switch. This switch will sense the temperature of the Exhaust rising during start up. If the Exhaust temperature does not reach 110 degrees F, or if, during use, the temperature drops below 110 degrees F, the Stove will go into “**Internal Alarm**” and the Auger will quit feeding fuel. Once the Stove completes the safety shutdown, the #3 LED will start blinking. *(Read Frequently Asked Questions for more information)*
2. The **High Limit** switch. This sensor will sense if the unit reaches temperatures that are too high for normal operation. If this happens the Auger will quit feeding and the #4 LED light will start blinking. *(Read Frequently Asked Questions for more information)*
3. The **Vacuum** switch. For the Stove to operate correctly the firebox needs to be sealed. During the first 30 seconds after the unit has been turned on, the control board will check to see if the switch senses negative pressure (Vacuum) in the firebox of the Stove. If there is no negative

pressure, the Stove will go into “Safety shutdown” and the #2 LED will start blinking. (*Read Frequently Asked Questions for more information*)

During “Normal Operation” a 60 second delay has been incorporated before the unit shuts down when the board senses loss of vacuum. This is to accommodate opening the doors during maintenance. Once the board senses loss of vacuum the ON/OFF light will start blinking. While the light is blinking the control board will not feed any fuel nor respond to any of the buttons. Once Vacuum has been restored the unit will revert to normal operation.

“Internal Alarm” - When the control board becomes unresponsive, the control board is in Internal Alarm. The control board has sensed one of the Safety sensors. This may cause the unit to go out and flash a Diagnostic Code. In some cases, after waiting approximately 45 seconds the Stove will start responding to the control board again. Many times, the cause of this is a change in the vacuum inside the firebox. This may be caused by excessive wind or by opening the Firebox door. The control board will monitor the vacuum switch and resume normal operation if the vacuum returns to normal.

“Power Reset” - If the board becomes unresponsive for a long period of time, you must unplug the Stove, wait 10 seconds and plug the unit back in to reset the board.

Safety Features

1. **”High Limit” switch**, an overheat safety switch will shut off the fuel feed if the Stove reaches temperatures above normal operating temperature. This is a “Normally Closed” switch. If the High limit switch trips several times, the problem in the Stove *must* be diagnosed before the unit is put back into service, (Defective Room Fan, dirty Room Fan, defective High Limit switch or possibly a bad Control Board)
2. **Vacuum switch** also called the **Negative pressure switch**. When the Stove is turned on the Exhaust fan will create a negative pressure in the firebox. The control board continually checks to see if Negative Pressure (vacuum) is present during operation of the Stove. If the exhaust venting system becomes clogged or obstructed, the firebox door is left open or the exhaust fan quits working the control board will go into “Safety shutdown”. There is a 60 second window to allow for cleaning the glass before then unit shuts down. This is sufficient for the Daily Maintenance
3. **Proof of Fire switch** also called the **P.O.F.** This senses the temperature rise in the exhaust system. The switch is “Normally Open” and closes the circuit at 110 degrees. The Stove will shut down if temperatures above 110 degrees F are not sensed during start up or if the temperature drops below 110 degrees during normal operation.
4. **Hopper Lid Switch**. The hopper lid switch will shut off the auger motor when the hopper lid is open. Be sure the lid closes completely when refilling the hopper or the unit will shut down

WARNING: The Stove has been Safety Tested by an accredited, independent laboratory. These safety features are designed to protect life and property. Bypassing these features voids all warranties and the safety listing of the stove.

Combustion Air Damper

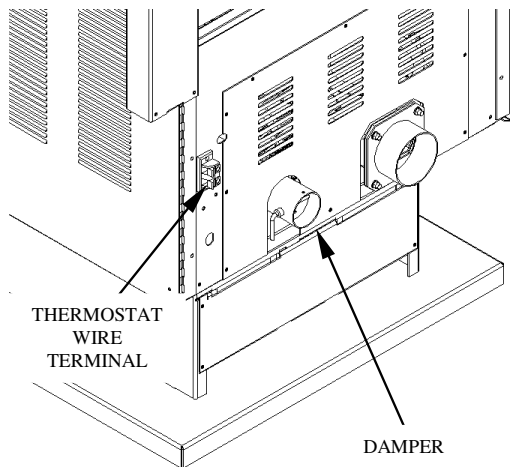

Figure 4

Damper Adjustment

When burning pellets make sure to check for the formation of creosote in the unit and venting system. Constantly running the stove on a low setting with too much combustion air may cause creosote to form. Burn pot temperatures can be “too cool” when burning on low with too much draft.

Adjusting the Damper may take a little time and patience, but only needs to be done once. After the damper has been adjusted to the venting system in your home, the control board will do the rest.

The purpose of this damper is to adjust combustion airflow to match the characteristic of each specific air inlet and chimney configuration. There is a setscrew in the damper (*shown in Figure 5*) and the damper has been preset at the factory. This setting will most likely work for 90% of the most common installations. Long horizontal runs might need the damper opened. Tall vertical runs might need the damper to be closed a little, etc. To adjust the damper, use the setscrew to make the adjustments. To make an adjustment turn the screw $\frac{1}{2}$ turn clockwise to open the damper or $\frac{1}{2}$ turn counter clockwise to close the damper. Remember to use the damper handle to bring the damper up to the screw. The damper will not close by itself. After making an adjustment wait at least 15 minutes to see how the burn pot reacts to the change. **Adjusting the damper during the break in period is very**

important (See “Preventing Chimney Fires” on page 3). Break-in requires the burning of 15 bags of pellets or continuous burn for two weeks. If during the initial break-in period you experience difficulty keeping the stove burning or there appears to be an excessive amount of burning pellets being evacuated from the burn grate, it may be necessary to close the damper some more. Once the damper is fine tuned for settings 1, 2, 3 and 4 the stove will run fine without having to make a change to the damper setting unless the stove is run on 5 for extended periods of time. It is normal for ash and some sparks to be continually evacuated from the burn grate. This is how the grate continuously cleans itself. The equivalent of a teacup of unburned pellets a day in the ash pan is considered normal.

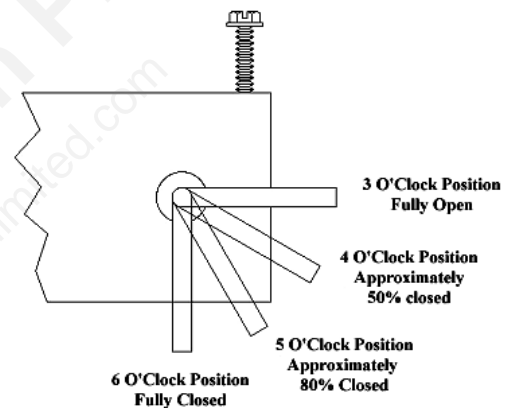

Figure 5

Flame Pattern Characteristics

Correct Flame Pattern - Bright yellowish-white flame with a brisk movement, having sharp pointed end tips extending up towards the Heat Exchange Tubes while forming a fan-like shape. Small amounts of ash and some live sparks being blown out from the Burn Pot area is considered normal operation.

Incorrect Flame Pattern - Dark orangish-brown flame with a lazy movement, having black smoky end tips curling up and over the Heat Exchange Tubes while forming a fireball-like shape. Some Ash or Live Sparks not being blown out from the Burn Pot area is considered abnormal operation. Extremely black soot forming on the ceramic glass surface is a sign of very poor combustion (not enough combustion air) and should not be overlooked. At the other end of the spectrum; an

extremely brisk flame which blows large pieces of live coal out from the Burn Pot area and causes stubborn shiny black build-up on the glass (too much combustion air) is also considered undesirable. **If you experience problems adjusting the stove during the Break-In Period, contact your dealer.**

MAINTAINING THE STOVE - The stove requires a minimum amount of daily maintenance. Required maintenance depends largely upon the quality of pellet fuel burned and the rate of burn. The amount of daily maintenance will increase if fuel quality decreases and/or the burning rate of pellets increases.

NOTE: FAILURE TO KEEP YOUR STOVE CLEAN, AS DESCRIBED IN THIS MANUAL, COULD RESULT IN POOR OPERATION, INEFFICIENT FUEL USAGE AND A POSSIBLE SAFETY HAZARD! IT IS YOUR RESPONSIBILITY TO DETERMINE NEEDED MAINTENANCE FREQUENCY.

The Versa Grate System (see Figure 6 below). The benefit of this feature is that the stove can operate for longer periods of time, with most

fuels, without the grate requiring cleaning. If the flame becomes dark orange, is accompanied by black smoke or burns with a lazy motion - it's time to clean the grate **When you first operate your stove or whenever you change fuels check to determine needed cleaning frequency.**

First, let's become familiar with the burn system in a St. Croix Pellet stove. Remember, cleaning frequency may change dramatically from one fuel to another. Pellets with high ash content or that have increased amounts of impurities or high moisture content. Every St. Croix Pellet stove model will have the same system as shown in figure 6 below. There is a 2-piece burnpot. The top Part is called the **"Grate Weldment"**. This sits on top of the **"Shaker Plate"**. This in turn sits on top of the **"Shaft/Cage Weldment"** and is held in place with the **"Spacer"** & **"Self Locking Twist pin"**. The Shaft/Cage weldment is moved towards the front of the stove and then towards the back of the stove by the **"Cam"** that is connected to the **"Versa Grate Motor"**. This motion is constant, while the stove is in operation. The only parts that may need to be removed for cleaning purposes during the Daily or Periodic Maintenance are the **"Grate weldment"** and the **"Shaker Plate"**. This is to check the holes in the burnpot system to see if they are plugged.

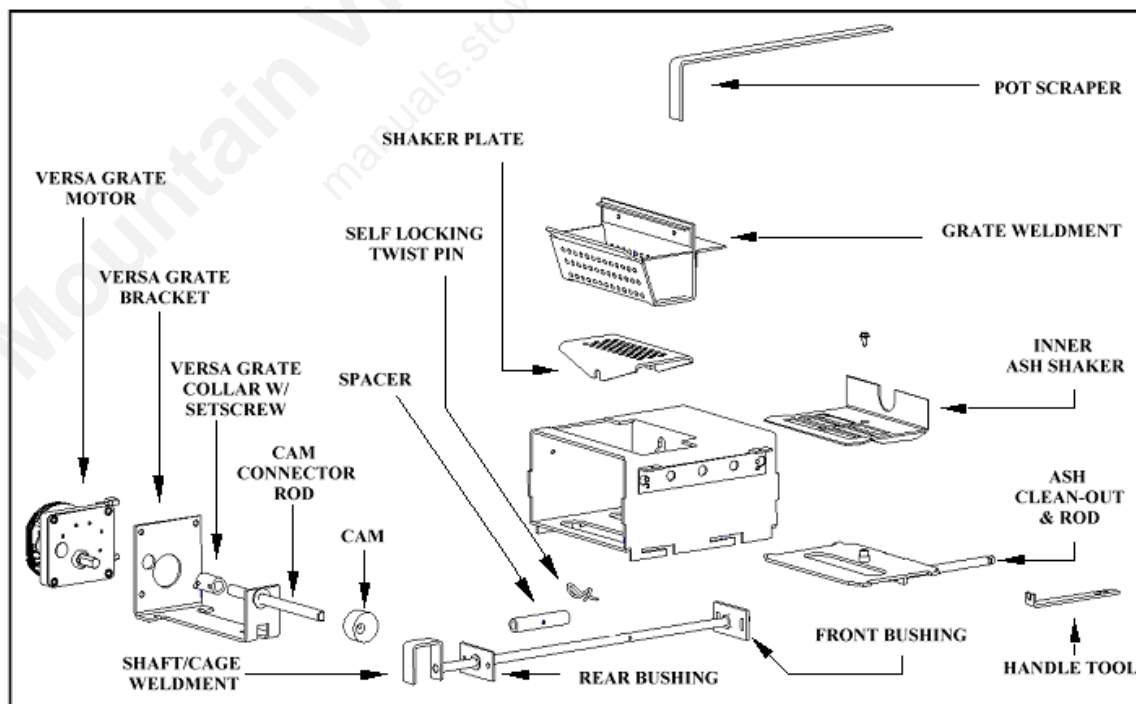

Figure 6

Daily Maintenance

1. Check Grate Weldment and Shaker Plate (See figure 7) to determine if holes are plugged. Clean as needed. With proper precautions the grate may be partially cleaned while the stove is hot. Follow these steps:

CAUTION: THE DOOR AND FRONT PART OF THE STOVE WILL BE HOT. DO NOT TOUCH ANY PART OF THE STOVE THAT IS HOT!

- a. Wear a leather glove that covers the lower arm.
- b. Turn the Stove to Heat Level 1 and allow the flame to burn down to a low burn.
- c. Open the firebox door slowly to prevent drawing ash or odors into the room.
- d. Use the “scraper” provided to move the burning pellets to one side of the grate, leaving the ash in the bottom of the grate. (See Fig 5 & 6)
- e. Rake the ash & clinkers out over the grate into the ash pan.
- f. Rake the burning pellets across the bottom of the grate.
- g. Close the door.
- h. Re-select the desired heat setting.

CAUTION: NEVER ADD FIRE STARTER TO A HOT STOVE.

2. Remove ash buildup under the grate bottom daily or as frequently as needed. Clean the ashes out from under the burn pot by pulling the Ash Cleanout Rod in and out several times (see Fig. 6) Use the Rod Pull Tool with the Ash Cleanout Rod. This tool is hanging on a screw on the back of the stove; this provides a convenient location to keep the tool in reach and prevent it from getting lost.

CAUTION: The Ash Cleanout Rod must be pushed all the way in during operation of the unit. Failure to keep this area clean could result in a safety hazard.

3. Check ash pan (See Fig. 6) to determine emptying frequency needed. NOTE: Do not use a vacuum cleaner for this purpose. Hot coals may cause your vacuum filter to catch fire. Place ashes in a metal container with a tight fitting lid. The closed container of ashes should be placed on a noncombustible floor or on the ground, well away from all combustible materials, pending final disposal. If the ashes are disposed of by burial in soil or otherwise locally dispersed, they should be retained in the closed container for at least two days until all cinders have thoroughly cooled.

4. Once or twice daily pull the Tube Scraper Rod, (See figure 7) out and back to clean heat exchange tubes. Failure to operate the tube scraper daily may result in poor combustion and loss of heat output. This should be done when the stove is cool or operating on the low temperature setting. Use the Rod Pull Tool shown in Figure 7 with the Tube Scraper Rod.

5. The rate of burn and the quality of fuel will determine how often the window needs cleaning. Prolonged burning at a slow burn rate will result in the need for more frequent window cleaning. Burning poor fuel also increases the need to clean the window. Cooling the stove and wiping the window daily with a cloth or paper towel will normally keep the window from accumulating difficult to clean residue. Use of a glass cleaner ONLY permitted when the stove is cold. *Tip: Dip the damp towel in the ashes to remove stubborn buildup on the glass.*

CAUTION: Do not slam the door. Do not operate the stove with a broken or cracked glass. Replace only with heat resistant ceramic glass supplied by the manufacturer.

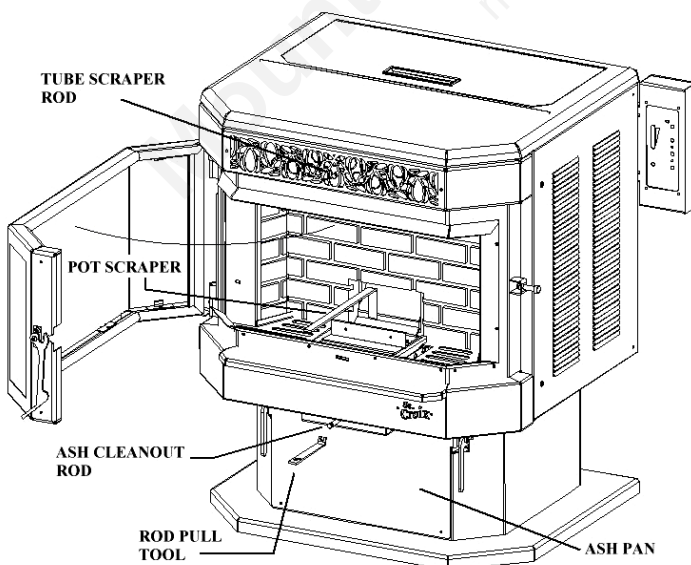

Figure 7

6. Burn the stove at the HI fuel setting for at least 20 to 30 minutes each day. This helps keep the window, ceraboard and firebox area clean. A daily high burn also aids in maintaining the overall efficiency and performance of the stove.

Periodic Maintenance

CAUTION: Periodic maintenance should only be done while the stove is shut off and cold.

1. Empty the ash pan when it appears full. This may range from 1 to 2 weeks in the Afton Bay. The frequency of cleaning the ash pan will depend on the quality and amount of pellets being used. Carefully check to make sure the ash pan door is tightly closed after each opening.

2. The Afton Bay has 3 Ash Traps/Clean-Outs, 2 of which are located below the rear brick panel. The third is located behind the Ash Pan. Remove covers and clean regularly. (See Figure 8 below) Be sure to clean both sides. Use scraper shown in figures 6 & 7 to scrape ash into ash pan. Use a vacuum (cold stove only) to thoroughly clean these areas.

IT IS CRITICAL THAT YOU KEEP ASH CLEAN OUTS CLEAN FOR SATISFACTORY PERFORMANCE.

Frequency of cleaning Ash Traps depends on the amount of fuel being burnt and the quality of the pellets. Fuel with low ash content is recommended.

Failure to clean the ash traps can cause the stove to become plugged with fly ash and could result in a Safety Hazard.

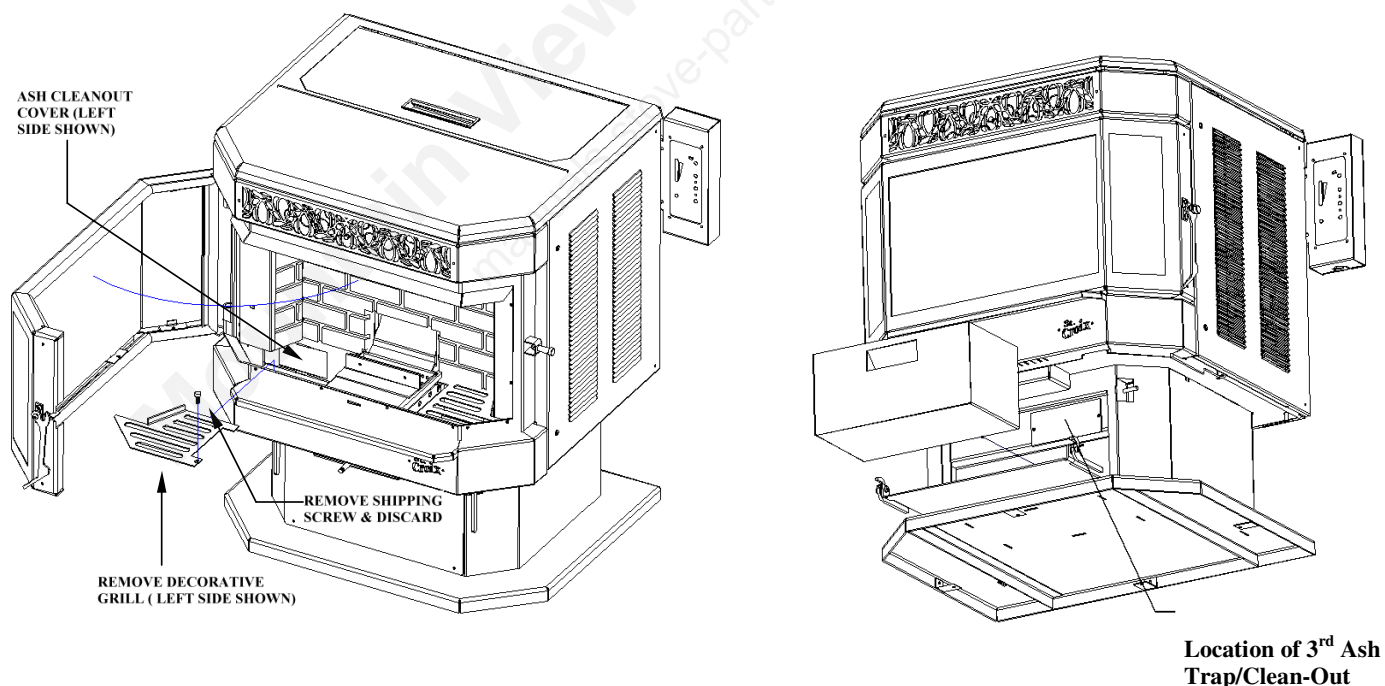

Figure 8

3. Clean burn grate holes at least weekly. Remove the burn grate and use a small metal object to clean out plugged holes. (See fig. 6 on page 12.)
4. Remove the baffle and clean the ashes that accumulate on a regular basis.

Frequency of cleaning depends on amount of fuel being burnt and the quality of the pellets. Fuel with low ash content is recommended.

Failure to clean the baffle can cause the stove to become plugged with fly ash and could result in a Safety Hazard.

To remove the baffle (See Figure 9), lift the back of the baffle up to clear the inner back of the stove and slide towards the front of the stove. The baffle will slide out of the keyhole slots and drop down. *When putting the baffle back in the stove, make sure the tabs are in the keyhole slots and the back of the baffle is lifted up over the inner back.*

5. Periodic cleaning of the exhaust system is required. Under certain conditions creosote buildup may occur rapidly. Low quality pellets and poor installations require more frequent chimney cleanings. **See Page 3 “Preventing Chimney Fires”**. The products of combustion will also contain small particles of fly ash. The fly ash will collect in the exhaust vent and restrict the flow of the flue gases. Judge the frequency of cleaning by checking the amount of ash that accumulates in the elbows or tee’s of the exhaust system. Ask the dealer for suggested frequency of cleaning, equipment needed and procedures for cleaning. Check the exhaust system at least once every two months during the heating season.

6. Periodically inspect the condition of the rope gasket around the door, window and ash door. Replace the gaskets in the stove as needed.

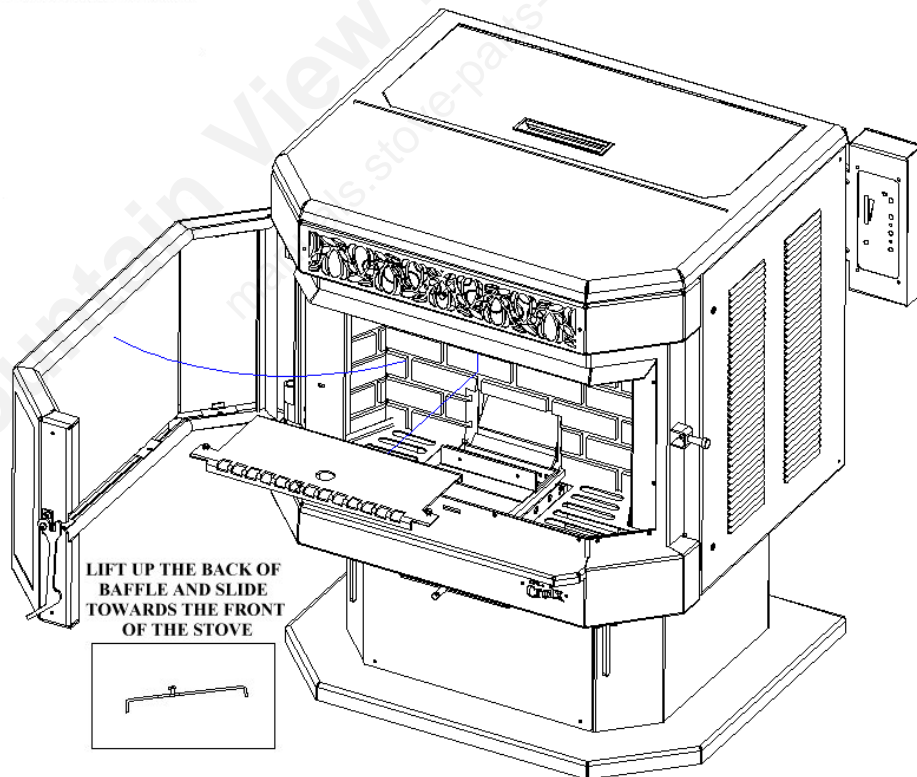

Figure 9

Yearly Maintenance

Yearly maintenance is designed to assure safe operation, prolong the life of the stove and help preserve its aesthetic appeal.

1. **Spring Shutdown.** After the last burn in the spring, cool the stove. Remove all pellets from the hopper and the auger. Thoroughly clean the burn grate, burn grate box, ash pan and ash traps behind the ash pan. (To locate the ash traps see Figure 8 on page 14)

NOTE: UNPLUG THE STOVE. Open the side panels of the stove. Carefully clean or vacuum any sawdust, cobwebs and household dust.

Carefully vacuum around the fan motors. If electrical wires become disconnected call your dealer for service.

2. The exhaust system should be thoroughly cleaned at least annually. Call your dealer for this service.
3. The motor/fan area behind the firebox and under the hopper should be vacuumed annually.
4. The Exhaust & Room Fan should be removed and cleaned annually. Call dealer for this service. Annual oiling of the motors is not needed. (See fig. 9 below for more information.)

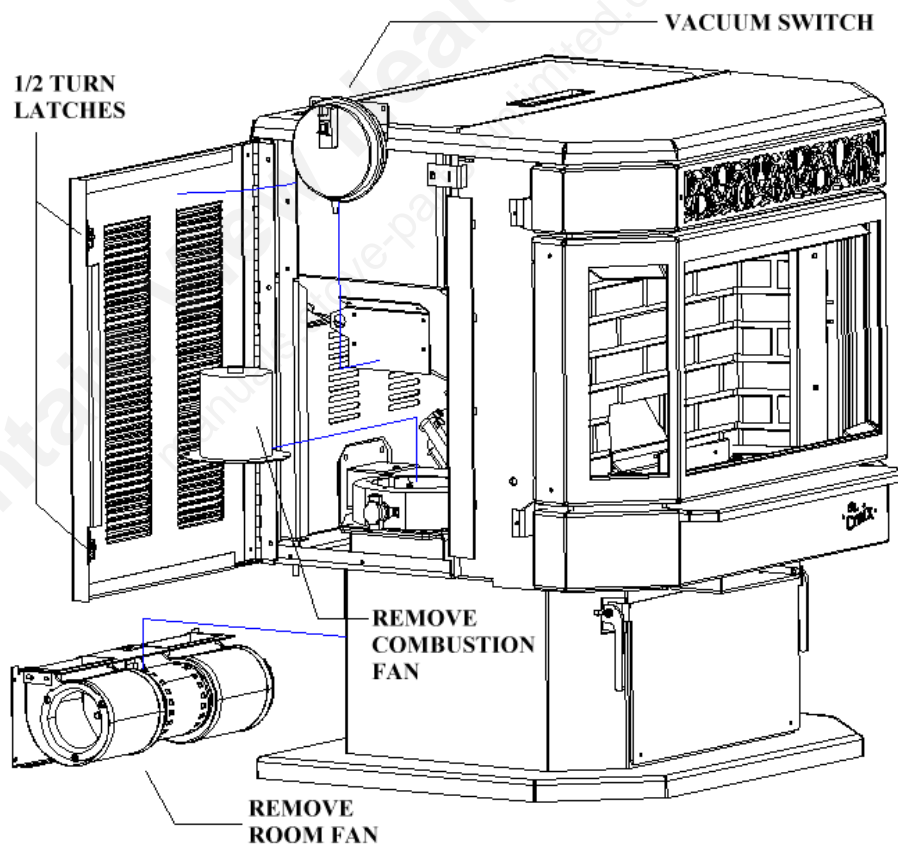

Figure 10

Note: The Vacuum Switch may be removed to allow easier access to the combustion fan

5. The Versa Grate System needs to be lubricated once a year with some High Temp Anti Seize to prevent the parts from “squealing” add some Anti-Seize to the Cam and Rod at both bushings. To gain access to the Versa Grate System in the Afton Bay open the right side panel when facing the stove. To locate the Rear Bushing assembly, follow the rod from the Shaft/Cage Weldment towards the front of the stove. The front bushing is located below the igniter in the front of the stove. Remove the ash lip cover as shown in figure 11.

Many dealers offer a Service Contract that will cover needed periodic and yearly maintenance. Contact your St. Croix dealer for assistance in maintaining your stove in top condition.

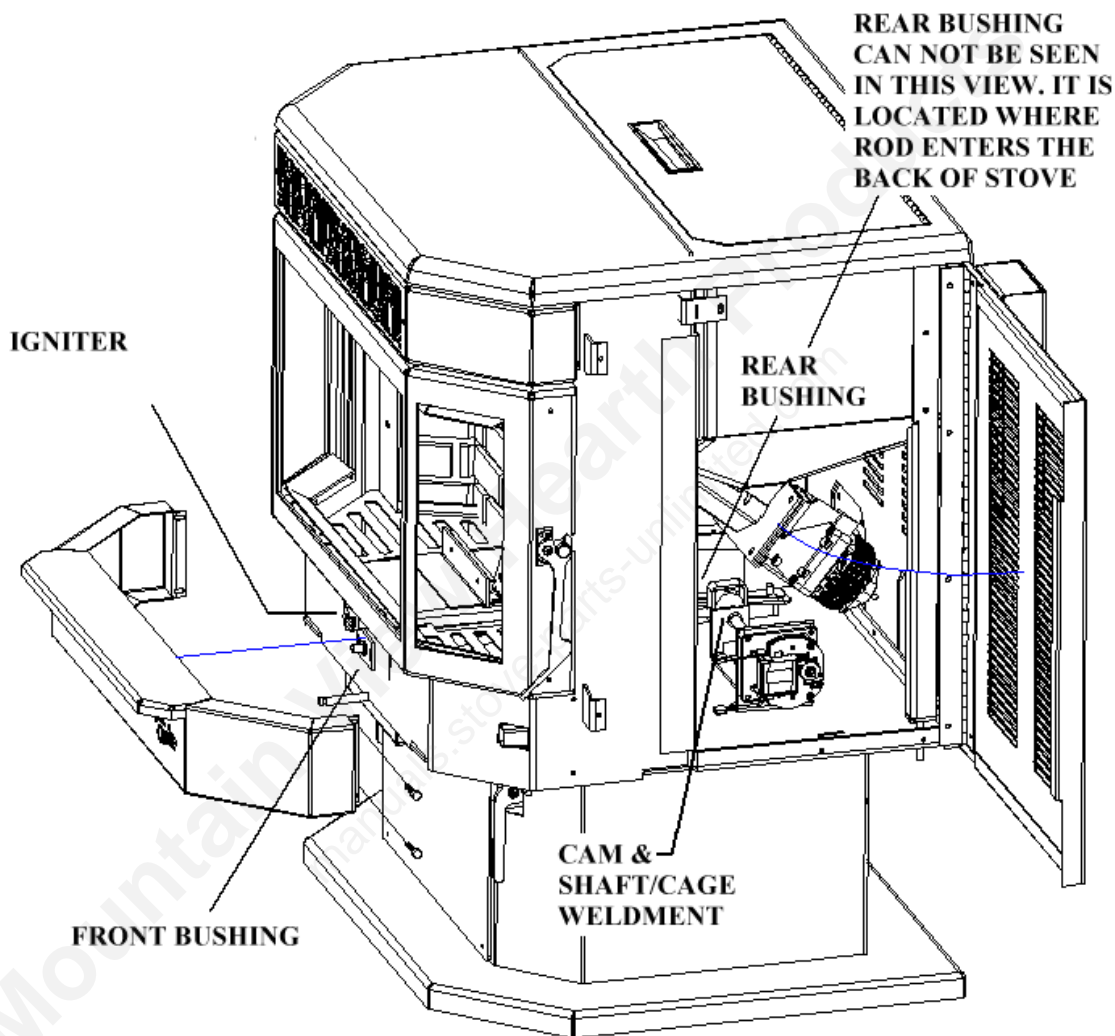

Figure 11

Fall Startup. Prior to lighting the first fire, check the outside area around the exhaust and air intake systems for obstructions. Try all controls to see that they are working prior to lighting a fire.

SAFE OPERATION.

1. **Disposal of Ashes.** Ashes should be placed in a metal container with a tight fitting lid. The closed container of ashes should be placed on a non-combustible floor or on the ground, well away from all combustible materials, pending final disposal. If the ashes are disposed of burial in soil or otherwise locally dispersed, they should be retained in the container until all cinders have thoroughly cooled.
2. **Never use Gasoline,** gasoline type lantern fluid. Kerosene, charcoal lighter fluid or similar liquids to start or “freshen up” a fire in this heater. Keep all such liquids well away from the heater while it is in use.
3. **Creosote, Soot and Fly Ash: Formation and Need for Removal.** The products of combustion will contain small particles of Fly Ash. The fly ash will collect in the venting system and restrict the flow of flue gases. Incomplete combustion, such as occurs during start-up and shut-down, or incorrect operation of the room heater will lead to some soot or creosote formation which will collect in the venting system. The exhaust system should be inspected regularly during the heating season to determine if creosote buildup has occurred. Check more frequently at first to determine a schedule for cleaning the venting system based on individual use of this Pellet-burning heater. If creosote has accumulated, it should be removed to reduce the risk of a chimney fire.
4. **Do not Overfire this unit.** Follow all instructions regarding the proper use of this heater.

CAUTION: The Electrical Components of the stove are not Owner Serviceable. Call your dealer for proper diagnosis of electrical problems and service to those components. See Installations Manual for a copy of the Wiring Schematic.

TROUBLESHOOTING & FREQUENTLY ASKED QUESTIONS

The Stove is very trouble free in operation when properly maintained and quality fuel is used. When the Stove fails to operate properly, troubleshooting by the operator of the Stove is limited. Please read the following guide for answers to frequently asked questions

1. When first starting your Afton Bay the auger tube is empty. This will delay feeding fuel to the burn pot. In some cases this will prevent the Stove from starting.

Solution: Prime the burn pot using the Auger Feed button if the auger tube is empty.

2. **My Stove keeps overloading the burnpot.** First check the Quality of your Fuel to make sure you are using clean fuel. Otherwise this is mainly caused by improper combustion settings. (See **Damper** Adjustment section of the Operations Manual) Besides the damper adjustment there are several areas that can have an effect on the combustion process.

Solution: Check all Gaskets, Doors and Door Latching Systems for air leaks. Any leaks in these areas will negatively affect the burn process and cause the pot to overload.

3. **My Stove isn't burning and the number 2 LED light is blinking.** This diagnostic light indicates the vacuum switch no longer senses negative pressure in the firebox area of the Stove. What caused the Stove to go out?
 - a. The door of the unit was left open longer than 60 seconds. (**See solution**)
 - b. The ash pan door was left open for longer than 60 seconds. (**See solution**)
 - c. The combustion fan is not running. (Defective fan or control board)
 - d. The vacuum switch is defective.
 - e. The vacuum hose is disconnected
 - f. The vent system is plugged with fly-ash.

Solution: *If the fire is out*, re-light the Stove. *If the fire is still burning* make sure all doors are securely latched and hold down the On/Off button (approximately 5 seconds) until Stove starts up again. This will re-start the Stove in the start-up program.

4. **My Stove isn't burning and the number 3 LED light is blinking.** This diagnostic light indicates that the Proof of Fire Switch no longer senses a fire in the Stove. First check to see if there is Fuel in the hopper. If there is fuel in the hopper check the following items to see why the Stove went out.

- a. Unburned fuel in the burnpot means the fire went out before the auger quit feeding.

Too much Combustion Air while burning on the Lowest Heat Level could cause the fuel to burn up too quickly and cause the fire to go out.

Solution: Too much Combustion Air on the pilot setting. Adjust the air damper or the combustion fan voltage. Fuel would still feed until the P.O.F. switch eventually shuts the Stove down. (See section covering *Damper Adjustment*)

- b. If all the fuel is burned up means the auger quit feeding fuel while there was still a fire in the burnpot. Check to see if there is fuel in the hopper. If the hopper is empty, fill the hopper and re-light the Stove.

If there is fuel in the hopper check to see if there is an obstruction in the auger system or if the auger set screw is loose.

Solution: Remove obstruction and re-light the Stove or tighten the setscrew on the auger shaft.

5. **My Stove isn't burning and the #4 LED light is blinking.** This means the high Limit has shut the Stove down. The Convection Blower could be defective or may need cleaning. The high limit switch may be also defective. It is best to call your dealer for support when trying to troubleshoot the High Limit Switch. Do not use your Stove if the High Limit switch frequently trips.

8. **I turned the Stove on with the On/Off switch and nothing happens.** First check to see if the Stove is plugged in and the receptacle has power to it.

Solution: Check the fuse on the back of the control board. Replace with a 125 Volt, 5 Amp fuse.

9. **Why is my glass dirty?** Normal operation of your St. Croix Stove will produce a light build-up on the glass that wipes off with a dry paper towel. However extended burning on the low setting only will produce a tan color. These types of build-up on the glass are normal. A heavy black build-up on the glass could indicate a problem.

Solution: Adjust the combustion air damper or combustion fan voltage. If this doesn't seem to help, make sure the clean out cover plates are installed in the Stove. It also could be an indication that the Stove is getting plugged and needs a good cleaning. Refer to the section in the manual that covers the Daily, Periodic and Yearly Maintenance of the Stove.

8. **Are there any adjustments that can be made, through the control board, to the amount of fuel that is fed into the burnpot?**

Answer: There are several ways to adjust the amount of fuel that is fed into the burnpot. The feedrates can be fine-tuned while the Stove is in operation by **pressing and holding** the “Auger Feed” button down and then **either** pressing the “Heat Level High” button to advance the feedrate higher, **or** pressing the “Heat Level Low” button to decrease the feedrate.

There are 5 levels on the control board and they are indicated by a single flash of the LED’s. The default setting is the center LED. This gives 2 adjustments increasing the feedrate (LED’s 4 & 5) and 2 adjustments decreasing the feedrates. (LED’s 1 & 2) The ON time is **increased or decreased** .25 seconds with each adjustment.

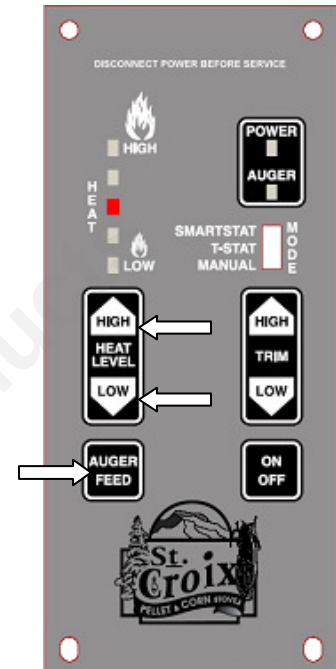

Figure 12

9. **Are there any adjustments that can be made, through the control board, to the Combustion Fan voltages to help adjust the draft?**

Answer: The Draft can be adjusted in a similar fashion as mentioned in the previous example.

The Fan voltages can be fine-tuned while the Stove is in operation by **pressing and holding** the “Auger Feed” button down and then **either** pressing the “Trim High” button to advance the voltages higher, **or** pressing the “Trim Low” button to decrease the fan voltages.

There are 5 levels on the control board and they are indicated by single flash of the LED’s. The default setting is the center LED. This gives 2 adjustments increasing the voltage (LED’s 4 & 5) and 2 adjustments decreasing the voltage. (LED’s 1 & 2) The voltage is **increased or decreased** 2.5 volts with each adjustment.

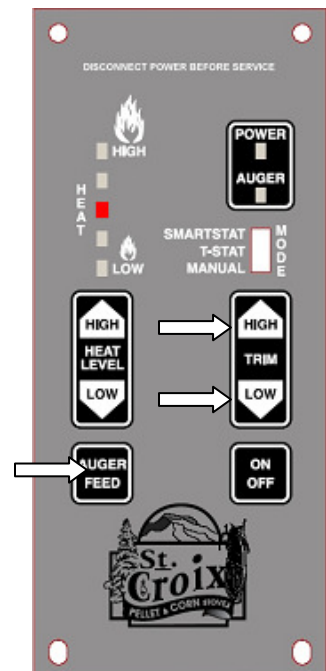

Figure 13

10. **Are there Cycle Time adjustments on the Control Board for different types of fuel?**

Answer: There are 4 individual programs on the control board, each with a different Cycle time. The Afton Bay only uses Programs 3 and 4

Your Afton Bay has been factory set to Program 3. When reprogramming the control board, you will see LED light flash, as shown in the figure to the right. The LED lights flash in the following manner:

- 1 - **Program 1.** The Cycle Time is 11.5 seconds. **THIS PROGRAM IS ONLY TO BE USED WITH OUR GRAIN BURNING MODELS. (DO NOT USE THIS PROGRAM WITH THE AFTON BAY).**
- 2 - **Program 2.** The Cycle Time is 13 seconds. **THIS PROGRAM IS ONLY TO BE USED WITH OUR GRAIN BURNING MODELS. (DO NOT USE THIS PROGRAM WITH THE AFTON BAY).**
- 3 - **Program 3.** The Cycle Time is 11.5 seconds. **THIS IS THE DEFAULT PROGRAM FOR USE WITH THE AFTON BAY.** This program is for use with **Pellets, Cherry Pits and a 50/50 Percent Mixture of Pellets and Corn (See point 11).** **(DO NOT USE THIS PROGRAM WITH OUR GRAIN BURNING MODELS).**
- 4 - **Program 4.** The Cycle Time is 10 seconds. **This Program offers Self-Ignition and is only for USE WITH CHERRY PITS. (DO NOT USE THIS PROGRAM WITH OUR GRAIN BURNING MODELS).**

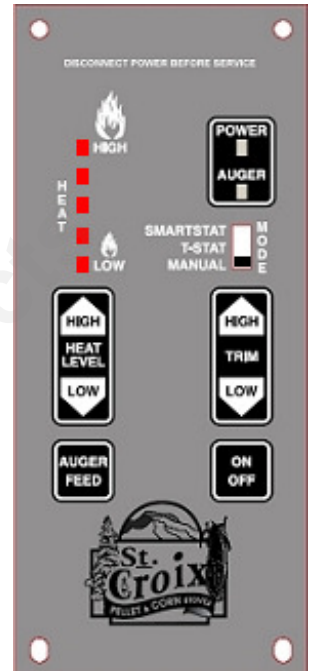

Figure 14

11. **How do I change to a different Program on the control board?**

First the Stove must be turned off and cooled down.

- Step 1 - The Thermostat switch must be in the **Manual** position.
- Step 2 – Press and hold the **Auger Feed** Button.
- Step 3 – Press the **Trim High and Low** Buttons. Release all 3 buttons at the same time.
- Step 4 – Observe the LED light flashing according to the Program chosen. Program 1 flashes once, Program 2 flashes twice, Program 3 flashes three times and Program 4 flashes 4 times.

Changing the Cycle Time will change the BTU Input of the Stove. The longer the Cycle time the lower the BTU rating.

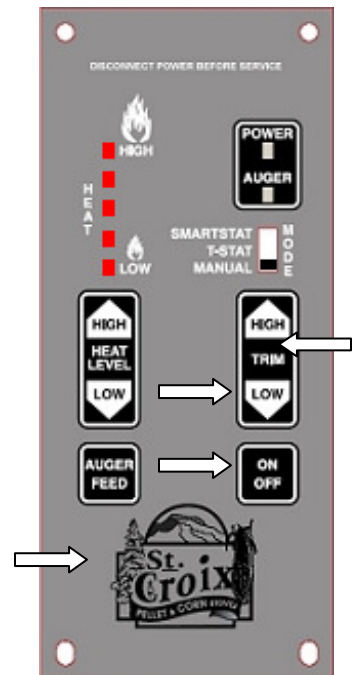

Figure 15

12. **The ON/OFF light is always blinking and the stove only runs on with a low fire, even though I have the Heat Level on #5.**

If the stove *is* operating on a Thermostat, this usually indicates a problem in the Thermostat circuit. There is either a bad connection in the wires or the Thermostat itself has a problem. Troubleshoot all of the components in the system.

If the stove *is not* operating on a Thermostat, make sure the slide switch on the control board is in the “Manual” position.

13. **I am running my stove on the SmartStat with a Thermostat and I can't shut the stove down.**
This may also be an indication of a problem in the thermostat circuit or of running the stove incorrectly. If the slide switch is set to “SmartStat” and the thermostat circuit is calling for heat, the stove cannot be shut off at the control board. You must first shut the thermostat off and then shut the stove off at the control board. If this isn't possible it may indicate a problem in the thermostat wires from the stove to the Thermostat or a defective Thermostat.

These questions and answers will usually solve most problems that you run into during the break-in period of the stove or if a component fails in the stove. Before calling your dealer for assistance, please read your **Operations Manual** and perform all the maintenance issues covered in the **Daily and Periodic Maintenance** section of the Manual. If the stove still does not operate correctly call your Dealer for Assistance.

PARTS LAYOUT - FRONT VIEW

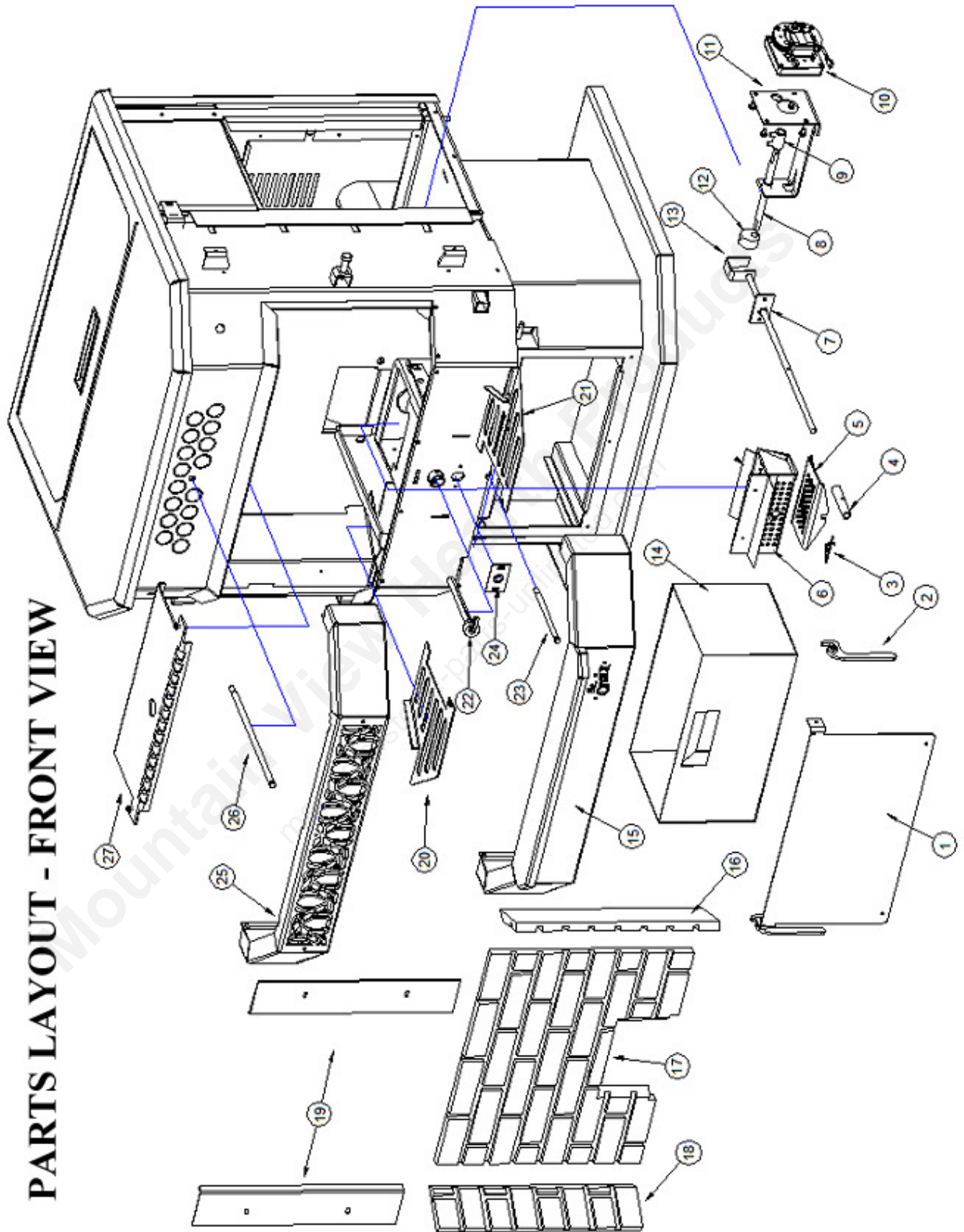

Afton Bay - Part Numbers & Descriptions

#	PART NUMBER	DESCRIPTION
1	80P53727-R	ASH PAN DOOR WELDMENT
2	80P52762-R	ASH PAN DOOR HANDLE
3	98360A100	SELF LOCKING TWIST PIN
4	80P50553-R	SPACER
5	80P52038-R	SHAKER PLATE
6	80P52980-R	GRATE WELDMENT
7	80P52955-R	REAR BUSHING ASSEMBLY
8	80P52376-R	CAM CONNECTOR ROD
9	80P52372-R	VERSA GRATE COLLAR W/ SETSCREW
10	80P20296-R	VERSA GRATE MOTOR
11	80P52953-R	VERSA GRATE BRACKET ASSEMBLY
12	80P50560-R	CAM
13	80P53695-R	SHAFT/CAGE WELDMENT
14	80P53726-R	ASH PAN WELDMENT
15	80P53794-R	LOWER PANEL
16	80P30593 -R	STEEL BRICK PANEL – RIGHT SIDE
17	80P30577-R	STEEL BRICK PANEL - BACK
18	80P30594 -R	STEEL BRICK PANEL – LEFT SIDE
19	80P52744-R	SIDE TRIM PLATE
20	80P52745-R	DECORATIVE GRILL – LEFT SIDE
21	80P30196-R	DECORATIVE GRILL – RIGHT SIDE
22	80P52727-R	IGNITER/HOT ROD
23	80P52627-R	ASH CLEANOUT ROD
24	80P52954-R	FRONT BUSHING ASSEMBLY
25	80P53770-R	HOT AIR BOX
26	80P52567-R	TUBE SCRAPER ROD
27	80P52944-R	HEAT EXCHANGE BAFFLE

CAUTION: The electrical components of the stove are not owner serviceable. Call your dealer for proper diagnosis of electrical problems and service to those components.

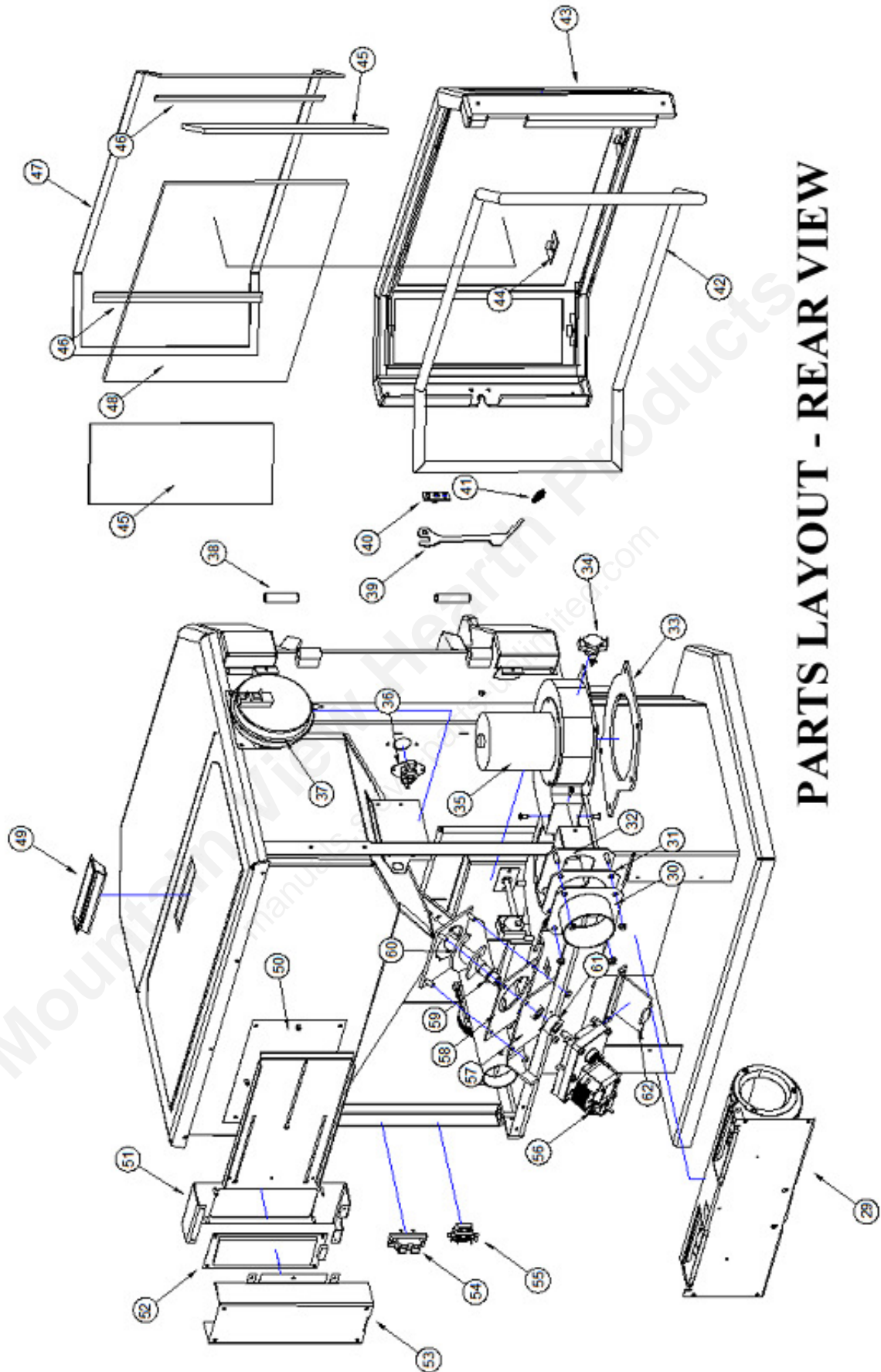

PARTS LAYOUT - REAR VIEW

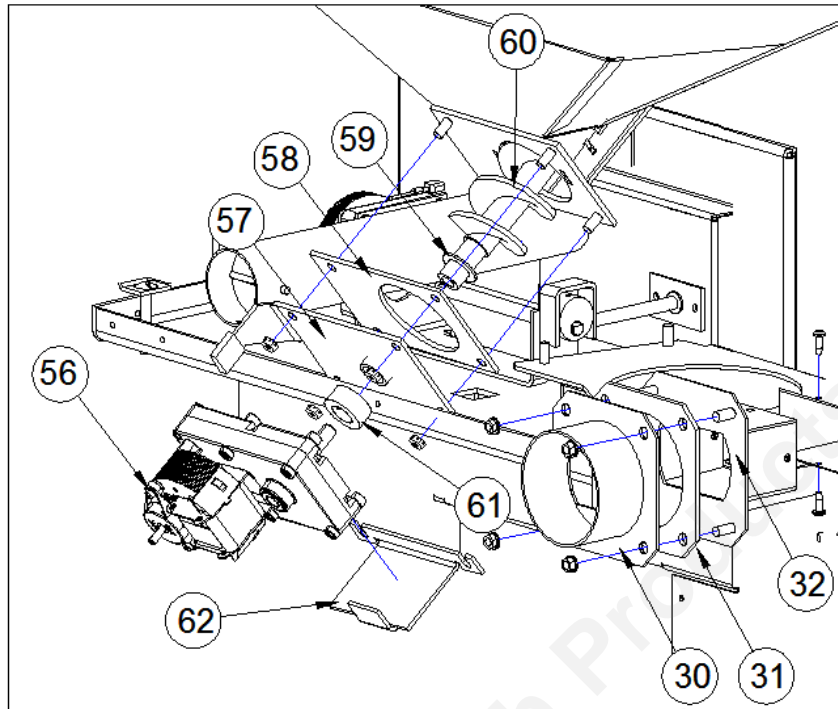

#	PART NUMBER	DESCRIPTION
29	80P53669-R	CONVECTION FAN ASSEMBLY
30	80P52887-R	QUICK CONNECT PIPE ASSEMBLY
31	80P52232-R	QUICK DISCONNECT GASKET
32	80P53667-R	EXHAUST ADAPTER PLATE WELDMENT
33	80P20168-R	COMBUSTION FAN GASKET
34	80P20038-R	PROOF OF FIRE SWITCH
35	80P20001-R	COMBUSTION FAN
36	80P52629-R	MANUAL RESET HIGH LIMIT SWITCH
37	80P52628-R	VACUUM SWITCH
38	80P65021-R	BAY DOOR HINGE PINS - 1/2" X 2"
39	80P53773-R	BAY DOOR HANDLE
40	80P53723-R	HANDLE MOUNT PLATE ASSEMBLY
41	80P20131-R	SMALL BRASS COIL FOR DOOR HANDLE
42	80P20026-R	DOOR GASKET - 5/8" ROPE
43	80P53724-R	BLACK DOOR FRAME WELDMENT
44	80P52796-R	GLASS CLIP
45	80P20035-R	SIDE BAY GLASS
46	80P20024-R	3/4" GLASS GASKET
47	80P20027-R	5/8" GLASS GASKET
48	80P20034-R	FRONT GLASS
49	80P20183-R	HOPPER HANDLE PULL
50	80P53681-R	SLIDE-TOP STANDOFF PLATE ASSEMBLY
51	80P53785-R	CONTROL BOARD MOUNT BOX
52	80P22348-R	CONTROL BOARD
53	80P52658-R	CONTROL BOARD HARNESS RESTRAINT
54	80P30045-R	WIRE TERMINAL - THERMOSTAT
55	80P52630-R	TERMINAL BLOCK
56	80P20278-R	AUGER MOTOR
57	80P52957-R	MOTOR MOUNT BRACKET ASSEMBLY
58	80P20245-R	AUGER GASKET
59	80P50858-R	AUGER BUSHING WASHER
60	80P53666-R	AUGER/SHAFT WELDMENT
61	80P20248-R	5/8" COLLAR WITH SETSCREW
62	80P30191-R	MOTOR RETAINER BRACKET

ST. CROIX AFTON BAY WARRANTY

The wood pellet stove and insert manufactured by Even Temp, Inc. is warranted for five (5) years, to the original owner, against defects and workmanship on all steel parts (excluding the burn grate) and two (2) year on electrical components from the date of sale to the original owner. There specifically is no warranty on the paint, glass, burn grate, brick panels and all gaskets. There is no written or implied performance warranty on the stove, as the manufacturer has no control over the installation, daily operations, maintenance or the type of fuel burned.

This warranty will not apply if the stove has not been installed, operated and maintained in strict accordance with the manufacturer's instructions. Burning other than high quality wood pellets that meet A.P.F.I. specifications may cause stove damage and could void the warranty.

The warranty does not cover damage or breakage due to misuse, improper handling or modifications.

A warranty registration card is provided. The card is to be checked and signed and returned to factory, by the owner. Appropriate information is to be noted on the card.

All claims under this warranty must be made through the dealer where the stove was purchased. If an inspection by the dealer indicates that a warranty claim is justified, and that all conditions of this warranty have been met, the manufacturer's total responsibilities and liabilities shall be to repair or replace, at the manufacturer's option, the defective part(s). All costs of removal, shipment to and from the dealer or manufacturer, any losses during shipment and reinstallation and any other losses due to the stove being removed shall be covered by the owner of the stove.

NEITHER THE MANUFACTURER, NOR THE SUPPLIERS TO THE PURCHASER, ACCEPT RESPONSIBILITY, LEGAL OR OTHERWISE, FOR THE INCIDENTAL OR CONSEQUENTIAL DAMAGE TO PROPERTY OR PERSONS RESULTING FROM THE USE OF THIS PRODUCT. ANY WARRANTY IMPLIED BY LAW, INCLUDING BUT NOT LIMITED TO IMPLIED WARRANTIES OF MERCHANTABILITY OR FITNESS, SHALL BE LIMITED TO ONE (1) YEAR FROM THE DATE OF ORIGINAL PURCHASE. WHEN A CLAIM IS MADE AGAINST THE MANUFACTURER BASED ON THE BREACH OF THIS WARRANTY OR ANY OTHER TYPE OF WARRANTY EXPRESSED OR IMPLIED BY LAW, MANUFACTURER SHALL IN NO EVENT BE LIABLE FOR ANY SPECIAL, INDIRECT, CONSEQUENTIAL OR OTHER DAMAGES OF ANY NATURE WHATSOEVER IN EXCESS OF THE ORIGINAL PURCHASE PRICE OF THIS PRODUCT. ALL WARRANTIES BY MANUFACTURER ARE SET FORTH HEREIN AND NO CLAIM SHALL BE MADE AGAINST MANUFACTURER ON ANY ORAL WARRANTY OR REPRESENTATION.

Some states do not allow the exclusion or limitation of incidental or consequential damages, or limitations of implied warranties, therefore the limitations of exclusions set forth in this warranty may not apply to you. This warranty gives you specific legal rights, and you may have other rights, which vary from state to state.

Notes:

After the break in period, please note any adjustments that were made to the Feed Trim and Draft Trim on the control board in the area below. In the event of a power failure or if the units gets unplugged, the trim settings will be lost.

Draft Trim: Circle one (See point 9 on page 21)

LED 1 LED 2 LED 3 LED 4 LED 5

Feed Trim: Circle one (See point 8 on page 21)

LED 1 LED 2 LED 3 LED 4 LED 5

Serial Number:

Date of Purchase:

Dealer Information:

**Even Temp, Inc.
P.O. Box 127
Waco, NE 68460**

EMAIL: support@stcroixstoves.com

WEB ADDRESS: www.stcroixstoves.com