

# Installation & Operations Manual



## Lincoln SCS

*With*

## SmartScan Maintenance Sensor

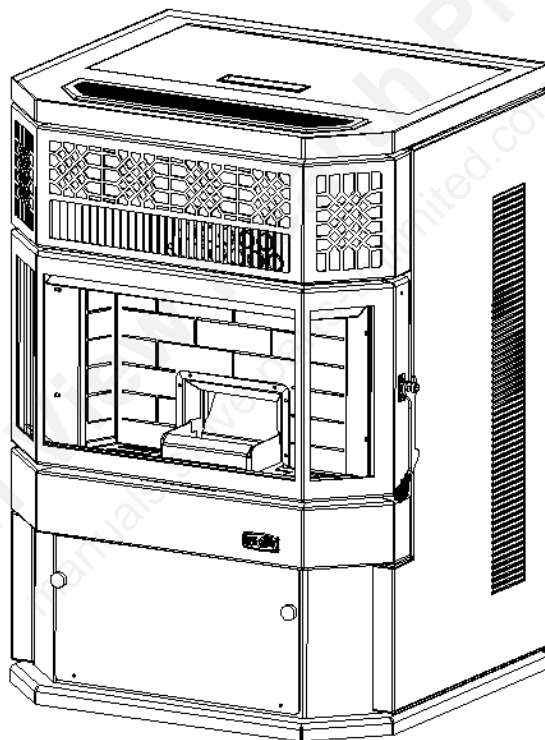

"Please read this entire manual before installation and use of this pellet fuel-burning room heater. Failure to follow these instructions could result in property damage, bodily injury or even death."

"Contact local building or fire officials about restrictions and installation inspection requirements in your area."

**Save these Instructions**

712

Lincoln SCS Manual

1

# TABLE OF CONTENTS

Quick Start Guide (Read this First) .....	4-8
General Information .....	9
Installation Check List .....	10
Stove Layout Diagram .....	11
Stove Dimensions .....	12
Approved Installations .....	13
Exhaust Venting.....	15
Venting - Approved Materials .....	15
Venting-Typical PL Vent Components.....	16
Venting - Determining Materials .....	17
Venting - Termination Requirements.....	18, 19
Venting: Termination Clearance Requirements .....	20
Venting – Into an existing Chimney.....	21
Venting – Hearth Mount.....	22
Floor Protection .....	23
Minimum Clearances to Combustible Materials .....	24, 25
Outside Combustion Air .....	26
Mobile Home Installation .....	27, 28
Thermostat .....	28, 29
Installation Check .....	29
Preventing Chimney Fires.....	30
Approved Fuels.....	30
Pellets, Corn, Wheat, Rye, Cherry Pits & Distiller’s Grain.....	31

St Croix SmartScan Maintenance Sensor .....	31, 32
The Revolution Burn System.....	33, 35
The Dual Hopper.....	36
Control Board Features .....	38, 39
Pre-Lighting Instructions .....	40, 41
Changing the Program on the Control Board .....	41
Lighting your Stove .....	42
Shutting Off the Stove .....	43
Combustion Air Damper Adjustment .....	43-46
Damper Adjustment & Pilot Setting, Thermostat Control.....	46
Diagnostic & Safety Features .....	47, 48
<b>Lincoln SCR Maintenance .....</b>	<b>49</b>
Daily Maintenance .....	49
Periodic Maintenance.....	50-52
Yearly Maintenance .....	53, 54
Safe Operation .....	54
Wiring Schematic.....	55
Parts Layout .....	56-66
<b>Troubleshooting &amp; Frequently Asked Questions .....</b>	<b>67-71</b>
Warranty .....	72
Stove Settings & Notes .....	73

# Installation & Operations

## Quick Start Guide

1. The fans of this Stove may cause a negative pressure area in the room where this Stove is installed.
2. Outside Combustion Air may be needed if:
  - The unit does not vent steadily, smells, experiences smoke rollout, burns poorly, or back drafts whether or not there is combustion present.
  - Any of the symptoms listed above are alleviated by opening a window slightly on a calm day.
  - The house is sealed with a well-sealed vapor barrier and tight fitting windows and doors and/or has any powered devices, which exhaust house air.
  - There is excessive condensation on the windows during the winter.
  - A ventilation system is installed in the house
  - Adhere to all Clearances and Restrictions specified in the Installation Instructions of this Stove.

When storing fuel be sure to use sealed containers in a dry environment to prevent the fuel from absorbing moisture and becoming damaged. Do not store bags of pellets directly on concrete.

- a. Establish a routine for the storage of fuel, care of the Stove and Firing Techniques.
- b. Check daily for creosote build-up until experience shows how often cleaning is necessary.
- c. Be aware that the hotter the fire, the less creosote is deposited, and that weekly cleaning may be necessary in mild weather, even though monthly cleaning may be enough in the coldest months. Run the Stove on the hottest setting once a day for 30 – 45 minutes to prevent excessive build-up in the Stove.
- d. Have a clearly understood plan to handle a chimney fire. Contact the local fire department for information if needed.
- e. Keep the doors closed and all seals in good condition while operating the Stove.
- f. **INSPECT THE FLUE PIPES, JOINTS AND SEALS REGULARLY TO ENSURE THAT SMOKE AND FLUE GASES ARE NOT DRAWN INTO, AND CIRCULATED BY THE AIR-CIRCULATION SYSTEM.**
- g. **CLEANING OF THE HEAT EXCHANGER, FLUE PIPE, CHIMNEY AND DRAFT INDUCER IS ESPECIALLY IMPORTANT AT THE END OF THE HEATING SEASON TO MINIMIZE CORROSION DURING THE SUMMER MONTHS CAUSED BY ACCUMULATED ASH.**
- h. Do Not Use Chemicals or Fluids to Start The Fire.
- i. Do Not Burn Garbage, Gasoline, Naphtha, Engine Oil, or Other Inappropriate Materials
- j. The Stove will not operate during a power failure, unless a Battery Back-up system is used during brief power outages. Prolonged Power Outages will require the use of a generator to operate the Stove.

## **How to adjust the Lincoln SCR for different Fuels?**

The Lincoln SCR is approved for 6 fuels. They are Pellets, Cherry Pits, Corn, Wheat, Rye and Distiller's Grain pellets. *Read pages 40 and 41 for information on choosing the correct program for the fuel of choice.*

The fuels are grouped in 2 categories:

- 1 – Pellets and Cherry Pits, lower in Moisture Content and easy to ignite.
- 2 – Corn, Wheat, Rye and Distillers Grain, these fuels are higher in Moisture Content and therefore more difficult to start.

### **The Lincoln SCR basically has 2 operating modes:**

1 - **Manual Mode.** In this mode the operator of the Lincoln SCR is involved with starting the unit, and is available to monitor the start-up process of the Lincoln SCR. This mode includes the **Manual** position and the **T-Stat** thermostat position. **Only the ON/OFF button will start the unit up or shut the unit down.**

2 – **SmartStat Mode** is the Automatic Mode. In this mode the Thermostat controls the unit. The Lincoln SCR starts as soon as the Thermostat calls for heat. The unit shuts off only after the unit pilots for 1 hour with out calling for heat. **If Operating in the SmartStat Mode, make sure the Thermostat is not calling for heat when trying to shut the stove off at the Control Board. Turning the unit off at the Control Board while the Thermostat is calling for heat, will cause the Control Board to turn the unit right back on.**

The Lincoln SCR must be set up and adjusted for proper ignition during the Break-In period and anytime a switch is made to a different Fuel Category, such as switching from Pellets or Cherry Pits (which have a lower moisture content and starts quicker) to burning Corn, Wheat, Rye and Distiller's Grain (which have a higher moisture content and start slower),. The Damper, Program, Feed and Draft Trim settings must be adjusted in such a manner that after the ignition cycle finishes the unit transitions to the fuel in the main hopper in a smooth manner without overloading the pot.

## **How to use T-Stat and SmartStat Mode with the Revolution Technology.** *(Read page 28, 29 and page 46 for more information on using a Thermostat)*

SmartStat Mode is to be used when the temperatures are mild. Adjust the Control Board for mild temperatures. Run the Lincoln SCR on the lower settings on the control board to prevent the unit from cycling on and off needlessly. If the temperature is 50 degrees outside, it would make sense to run the Lincoln SCR in SmartStat Mode but with the Heat Level set on #1. This way the unit puts out less heat and will run longer before temperatures in the house rise above the Thermostat setting. This also provides a more even temperature.

When burning Corn, Wheat, Rye and Distiller's Grain Pellets, the program chosen must give a smooth ignition and be able to advance to the Heat Level chosen. If the Pot overloads during ignition, adjust the Feedrate down or switch Programs until these fuels ignite without overloading the Pot. The units must be adjusted for unattended use.

**Do not assume the unit functions correctly in SmartStat mode without first adjusting the unit. When burning grain there are many variables and the unit must be fine tuned correctly before using SmartStat Mode.**

The adjustments that need to be made are:

- 1 - Choosing the correct Program for the fuel used. (See pages 40-41 in your manual)
- 2 - Adjusting the Damper (if needed) (See pages 43-46 in your manual)
- 3 - Adjusting the Feedrate (if needed) (See point 10 on page 70)
- 4 - Adjusting the Draft Fan Voltage (if needed) (See point 11 on page 70)
- 5 - Adjusting the Heat Level to a lower setting (to prevent the Lincoln SCR from excessive ON/OFF cycling). This will also help in maintaining an even temperature in the home. (See figure 29 on page 38) Moving to the next Program will also produce less heat. (See pages 40-41 in your manual)

If the Revolution pot overloads during the Ignition Phase, simply open the Hopperlid to stop the Auger Motor in the main hopper. This will temporarily shut off the fuel that is being fed to the pot until it balances back out.

*Use the 5-point list above and make some small adjustments before starting the unit the next time. Again observe how the unit starts up and repeat this process until you get a smooth ignition when burning Grain.*

## **The Revolution Pot – How to deal with a jammed pot.**

### **What can cause the pot to get jammed?**

- a – A foreign object gets stuck in the Drum as it rotates through. For this to happen, the object must first make it through the Auger system in the hopper. Most likely it would jam the auger, but in some instances it could end up in the pot.
- b – The Drum rotates while it is full of unburned fuel. If this happens the dividers in the drum could get stuck on the fuel as that section of the pot rotates through. It jams where the dividers close the opening where the Ash and Clinker material exit the pot.

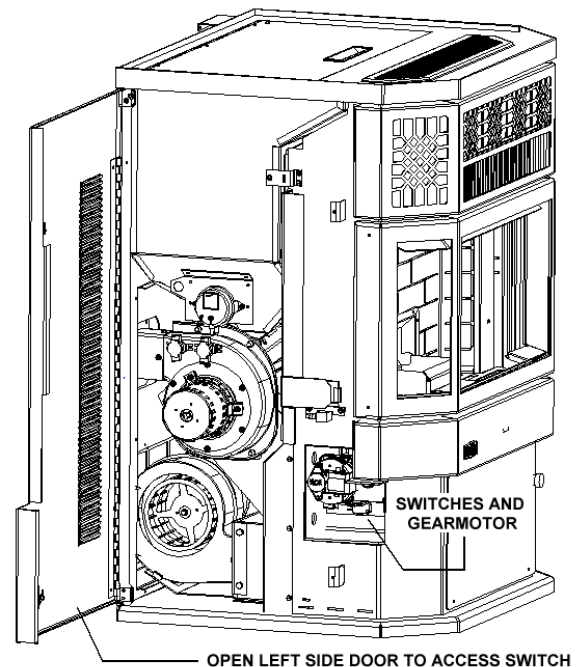

Figure 1

**How to fix the problem if it happens?**

**First unplug the unit** and use a vacuum to clean out the fuel or ash in the pot. To clear a foreign object, may require reversing the motor by hand. Figure 1 shows how to access the area where the Switch and Revolution gearmotor are located.

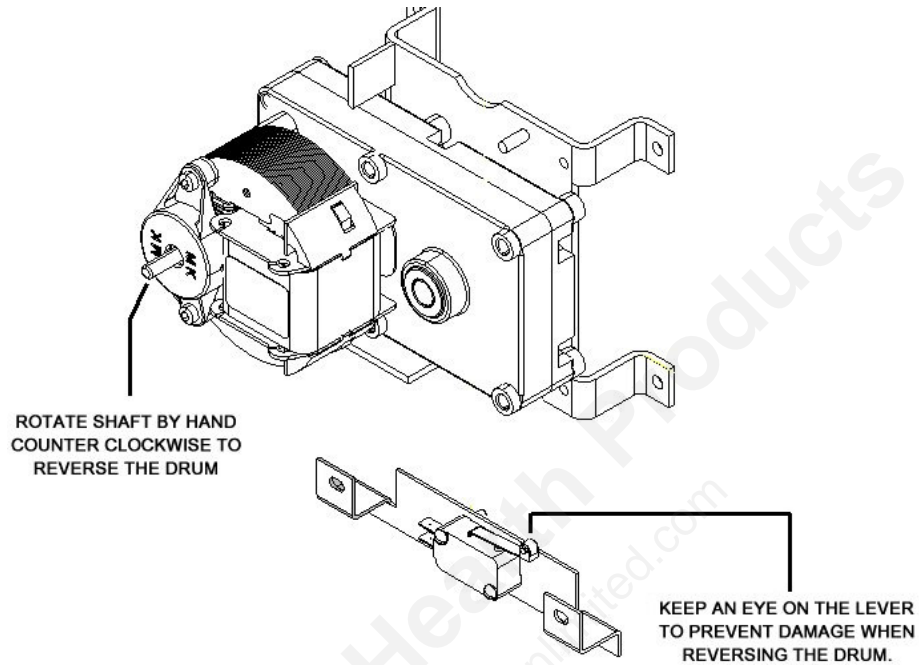

Figure 2

Keep an eye on the switch lever shown in figure 2. It eventually will end up against the end of the notch shown in figure 3. Rotating any further than that will bend the lever and potentially damage the switch.

**To clear a jam usually only requires the drum to be reversed a small amount for the object or the fuel to free up.**

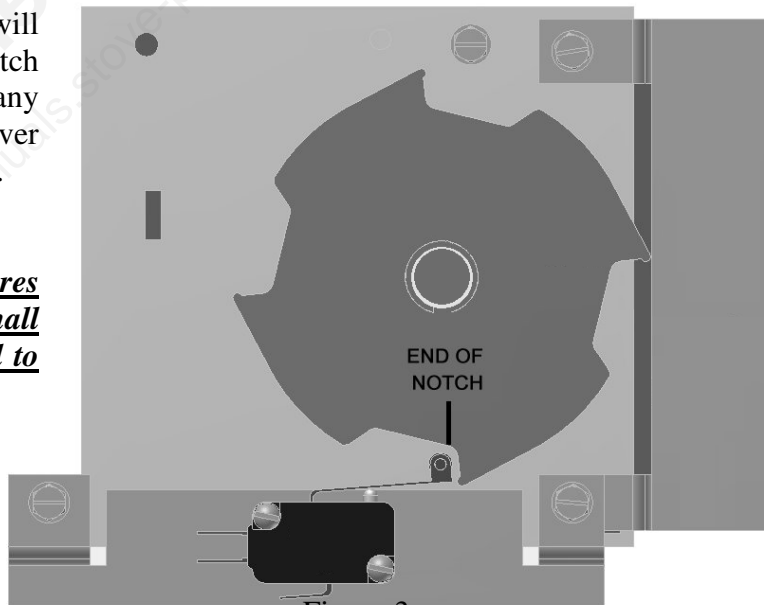

Figure 3

**Once the jam has been cleared, simply plug the unit back in and the drum will rotate through and stop in the correct position.**

There is one other situation that could jam the drum. When burning Corn, Wheat, Rye or Distillers Grain Pellets the by-product of these fuels is a hard clinker. If the pot jams on the Clinker material, the procedure to clear the drum is a little different from the method listed on the previous page.

**Remember to first unplug the unit before trying to clear the jam.** The clinker material may be stuck to the “Divider Fingers” in the drum. This Clinker material is hard and easily breaks up into smaller pieces using a hammer and screw driver.

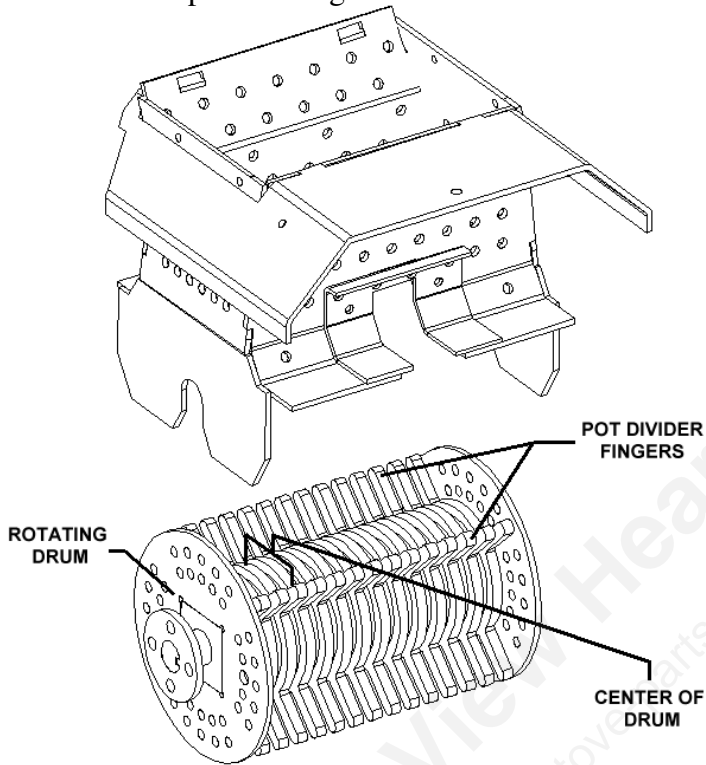

Figure 4 shows the Drum outside of the burnpot for a clearer view. Note the “Divider Fingers” and the “Center” of the Drum.

**When breaking up a Clinker use caution not to hit directly on the divider fingers as this may bend them and cause them to bind on the “Cutters”. Break the Clinker up in the area described as the “Center of Drum”**

Figure 4

#### **How to prevent the Clinker from causing the Drum to jam?**

The fuels that create Clinkers are approved with Programs 2 through 4 on the Control Board. The Clinker can be different in consistency based on the different varieties of corn, wheat and rye that are grown or produced throughout the US. If this seems to be a problem, simply choose the next program on the Control Board.

**For Example: If you are operating in Program 2, simply change to Program 3. This will cause the Clinker to be smaller and less likely to jam up during the cleaning process. Also see point 10 on page 70 for information on reducing the feed rate of the fuel within the program itself.**

# Save This Installation & Operations Manual

## GENERAL INFORMATION SAFETY PRECAUTIONS

***SAFETY NOTICE: The Stove must be properly installed in order to prevent the possibility of a house fire! These installation instructions must be strictly observed! The Maintenance schedule must be followed as described in this manual. Failure to follow instructions may result in property damage, bodily injury or even death.***

The Stove's exhaust system works with negative combustion chamber pressure and a slightly positive chimney pressure. Therefore, it is imperative that the air intake and exhaust system be airtight and installed correctly. Do not install a flue damper in the exhaust vent of this unit.

Do not connect this unit to a chimney flue serving another appliance.

### **BUILDING PERMIT**

Contact the local building officials to obtain a permit and information on any local installation restrictions and inspection requirements.

### **DEFINITION OF "STOVE"**

The word "Stove" as used in this manual is interpreted to mean a "Multi-Fuel Stove" approved for the fuels listed in this manual. This model is not intended as the sole source of heat.

### **SAFETY TESTING**

The stove has been independently tested and listed by Warnock Hersey Laboratories in accordance with the proposed ASTM Standards and the applicable portions of UL 1482-90 and ULC S627, ASTM E 1509-04 and Oregon Administrative Rules 814-23-901 through 814-23-909, stating requirements for installation as a stove, heater or hearth insert for masonry, metal and zero clearance fireplaces and for mobile home installations. The safety-listing label is located on the back of the stove.

### **DISCLAIMER OF WARRANTY**

Since Even Temp Inc. has no control over the installation of the Stove, Even Temp Inc. grants no warranty, implied or stated, for the installation of the Stove and assumes no responsibility for any special, incidental or consequential damages.

### **MANUFACTURED BY:**

Even Temp Inc  
Hwy 34  
Waco, NE, 68467

Lincoln SCS Manual

# **BEFORE INSTALLATION THOROUGHLY READ AND UNDERSTAND THIS MANUAL**

## **SAFETY NOTICE**

**PLEASE READ THE ENTIRE MANUAL BEFORE INSTALLING AND USING YOUR NEW STOVE. FAILURE TO FOLLOW INSTRUCTIONS MAY RESULT IN PROPERTY DAMAGE, BODILY INJURY, OR EVEN DEATH.**

## **INSTALLATION CHECK LIST**

**FOR USE IN THE U.S. AND CANADA**

**MOBILE HOME APPROVED**

**CHECK WITH LOCAL AUTHORITIES AND OBTAIN NEEDED PERMITS**

**WE RECOMMEND INSTALLATION BY A QUALIFIED PROFESSIONAL.**

### **BEFORE STARTING THE STOVE FOR THE FIRST TIME**

1. Under certain conditions outside combustion air is recommended. Use only approved parts. When using outside air for combustion, check that the outside air inlet is connected to draw fresh air from outside the building.
2. All joints of PL vent and single wall stainless steel pipe should be fastened by at least 3 screws and correctly installed. (Follow vent manufacturer's instructions). Seal all joints with high temperature silicone to create an airtight seal.
3. **WARNING:** The high temperature paint on this Stove may take several hours of burning at a high fuel setting to cure fully. During this time, an odor that is not harmful may be evident. When odors are present, the area around the Stove should be well ventilated.
4. **Caution:** The high temperature paint can be easily scratched prior to burning the Stove.

**CAUTION:** FAILURE TO FOLLOW THE INSTRUCTIONS IN THE INSTALLATIONS MANUAL MAY RESULT IN A HOUSE FIRE. PLEASE FOLLOW INSTALLATION AND MAINTENANCE INSTRUCTIONS.

# Lincoln SCR

## Stove Layout

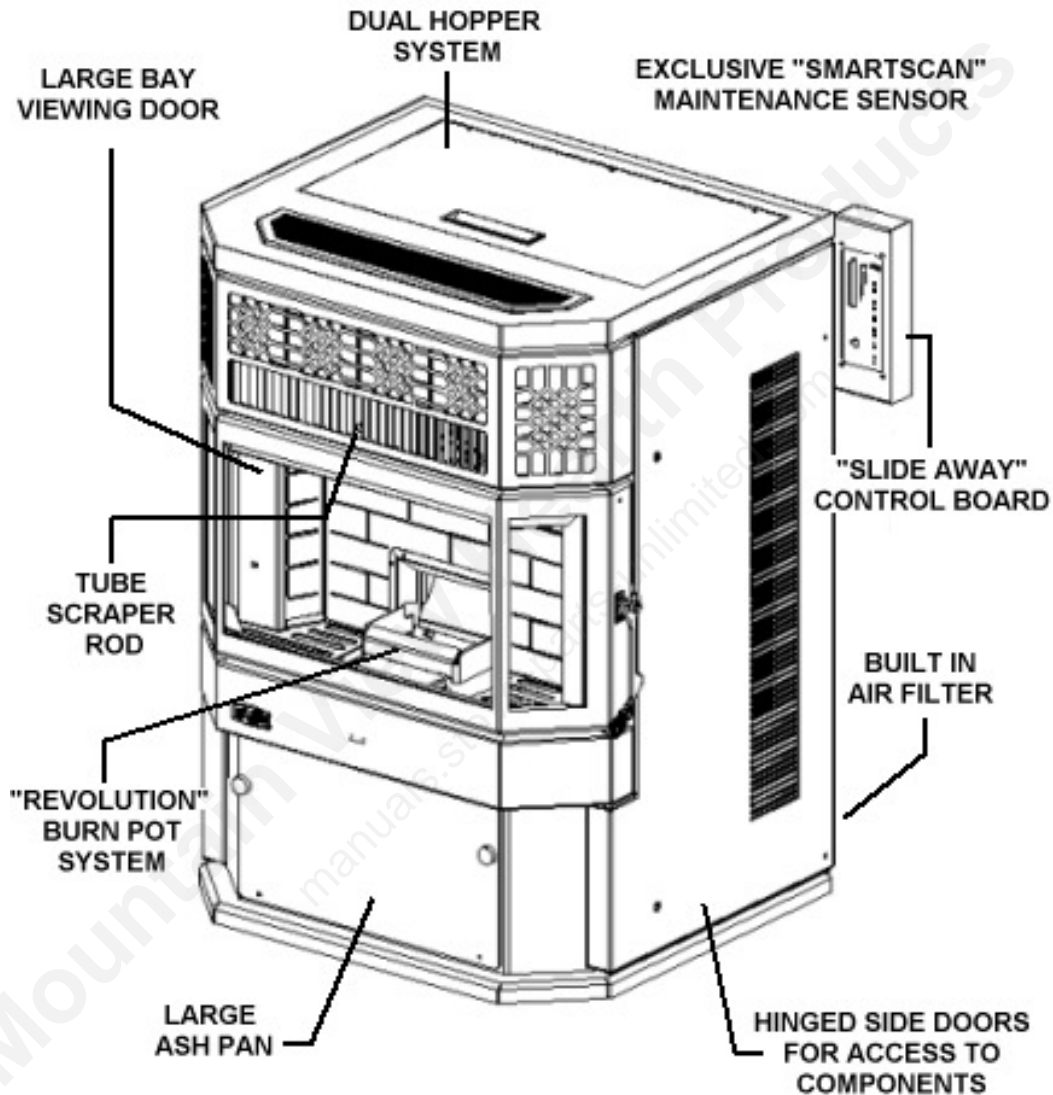

Figure 5

The burn system used in the Lincoln SCR is the St. Croix Patent Pending "**Revolution Burn System**". This burn system removes the ash/clinker from the pot on timed intervals. This system utilizes a Patent Pending **Dual Hopper System** that uses wood pellets to ignite the Fuel that is in the main hopper. It is approved for Pellets, Corn, Wheat, Rye, Cherry Pits & Distillers Grain Pellets.

# STOVE DIMENSIONS

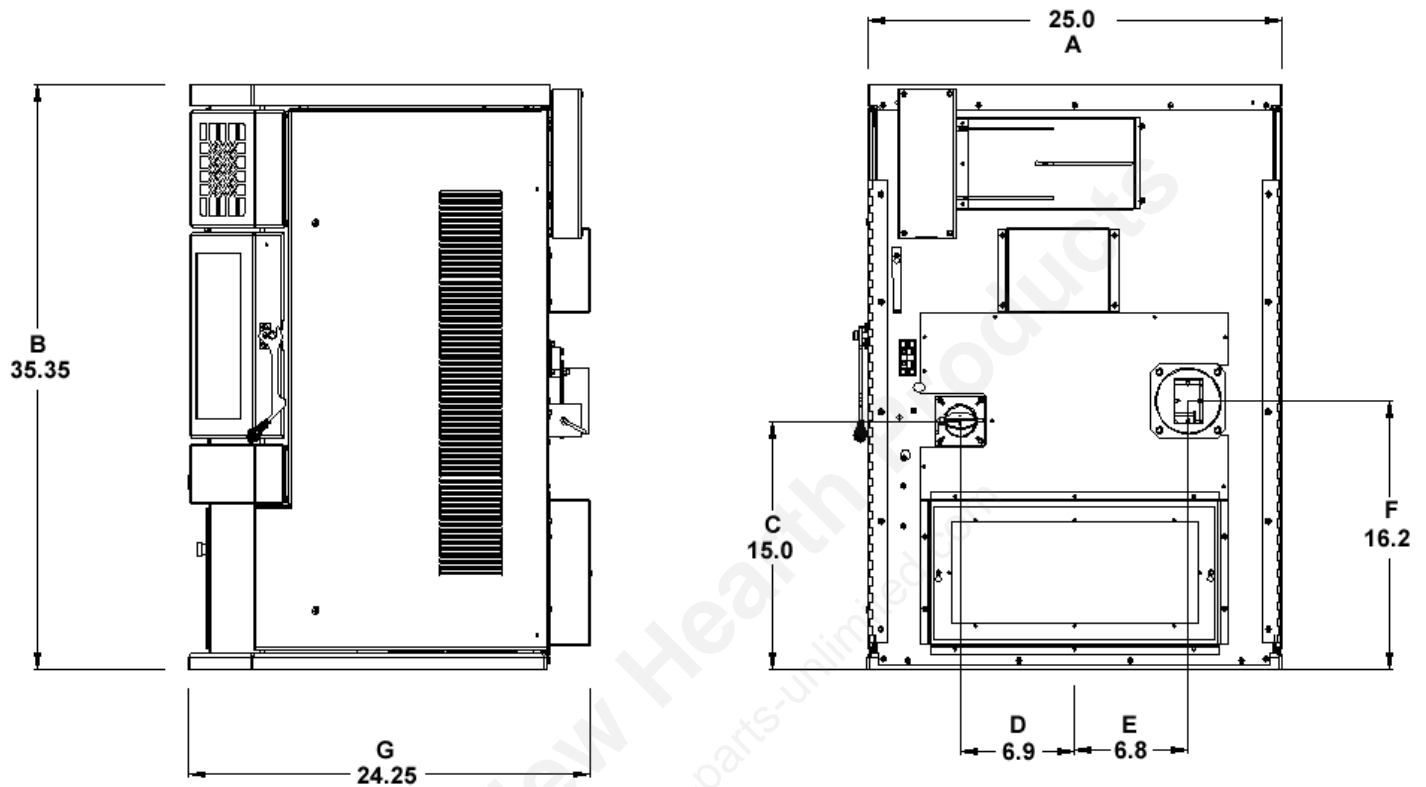

Figure 6  
Rear & Side View

A – Width of Stove

B – Height of Stove

C – Center of Air Intake from Floor

D – Center of Stove to Center Intake

E – Center of Stove to Center of Exhaust

F – Center of Exhaust from the Floor

G – Depth of Stove

# Approved Installations

The Lincoln SCR is approved for CONVENTIONAL and MOBILE HOME installations as a FREESTANDING stove. The stove may also be installed on the Hearth in front of a fireplace and vented through the chimney of the fireplace.

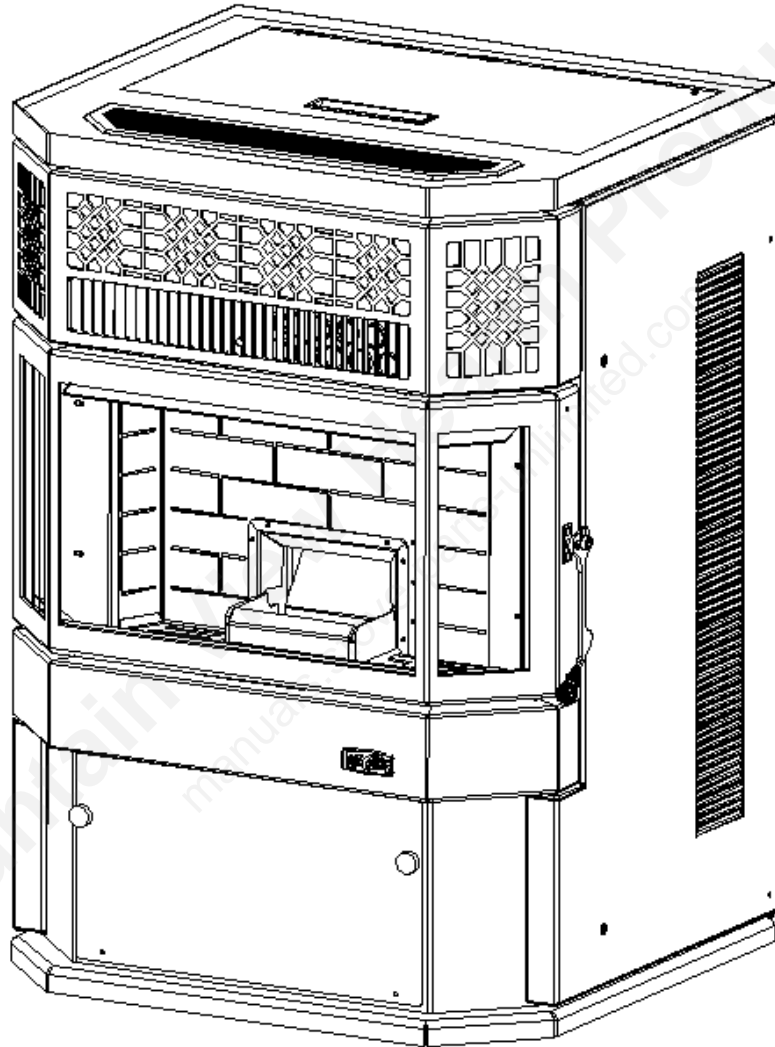

Figure 7

# Caution

**INSTALLATION IS TO BE PERFORMED BY A QUALIFIED INSTALLER OR DEALER.**

**ADHERE TO ALL CLEARANCES SPECIFIED BY THE MANUFACTURER OF THE VENTING SYSTEM USED.**

**ADHERE TO ALL CLEARANCES SPECIFIED IN THE INSTALLATION INSTRUCTIONS OF THIS STOVE.**

**THIS STOVE USES A POSITIVE PRESSURE VENTING SYSTEM. DO NOT INSTALL A FLUE DAMPER IN THE EXHAUST SYSTEM OF UNIT**

**DO NOT CONNECT THIS STOVE TO A CHIMNEY SYSTEM THAT IS CONNECTED TO ANOTHER APPLIANCE.**

**DO NOT INSTALL THIS UNIT IN A SLEEPING ROOM**

## ATTENTION

**CONDENSATION:** When planning the installation of your Stove, keep in mind that condensation is detrimental to exhaust systems. Corn, Wheat, Rye & Distiller's Grain have higher moisture content than pellets and can be more susceptible to condensation forming in certain types of installations. Install the Stove with a minimum of the system exposed to the cold temperatures outside the envelope of the house. Check with the manufacturer of your venting system that they honor the warranty of their PL Vent with the use of corn.

## ATTENTION

**BATTERY BACKUP:** Battery backup systems are useful if the Stove is installed using horizontal venting only. This prevents any smoke from entering your home in the event of a power failure.

## VENTING: APPROVED MATERIALS

The Stove requires a venting system approved for pellets by a certified testing lab. Approved pellet Stove venting materials are: 1) PL vent, a double wall vent with a stainless steel liner; and 2) Single wall rigid or flexible stainless steel pipe. PL Vent and Single wall vent is available through manufacturers such as (but not limited to): ICC Chimney, Energy Vent LTD, James A. Ryder, Simpson DuraVent and Selkirk Metalbestos and is carried by many local pellet Stove dealers. In this manual approved venting will be referred to a “PL vent” or “Single wall vent”. All single wall vent adaptors must be stainless steel.

NOTE: TYPE “B” GAS VENT MUST NOT BE USED IN THE INSTALLATION OF THIS STOVE

Examples of venting system components follow:



High temperature ceramic roping reduces potential fly ash escaping through joints.

Stainless steel inner liners resist corrosive flue gas damage to the system.



Flex pipe should be stainless steel, 4 ply construction with a total thickness of approximately .07 inches.

## TYPICAL PL VENT COMPONENTS



*RAIN CAP  
VERTICAL OR  
HORIZONTAL*



*WALL THIMBLE*



*CHIMNEY  
ADAPTER*



*SUPPORT BRACKET*



*ADJUSTABLE LENGTH  
PIPE*



*SINGLE TEE  
w/TEE CAP*



*SINGLE REDUCTION  
TEE w/TEE CAP*



*DOUBLE TEE  
w/TEE CAP*



*PIPE ADAPTER*



*INCREASER*



*45° ELBOW*



*90° ELBOW*

## VENTING: DETERMINING MATERIALS

### TYPE OF MATERIALS:

1. *PL Vent must be used.*

2. **Exception: Single wall stainless steel may be used inside an existing chimney.** (No clearances to combustibles are needed on single wall stainless steel adaptors, rigid or flex pipe installed within a chimney.)

3. A clean-out “tee” (PL Vent or “Quick-Connect Exhaust”) must be installed directly to the Stove and at the bottom of each vertical run of the exhaust system. These tees are to assist in periodically cleaning the pipe. Single or double clean-out tees may be used. **The exhaust system must be installed so the entire system can be cleaned without disassembly.**

NOTE: ADHERE TO THE PL VENT CLEARANCES TO COMBUSTIBLES AS REQUIRED. STRICTLY OBSERVE THE PL VENT MANUFACTURER’S SAFETY SPECIFICATIONS.

### QUANTITY OF MATERIALS:

1. It is recommended that the vent system be installed with a **minimum of three feet (3’) of vertical rise** above the exhaust port on the back of the Stove.

FAILURE TO PROVIDE THE NATURAL DRAFT THAT RESULTS FROM A VERTICAL RISE MAY RESULT IN SMOKE BEING RELEASED INTO THE HOUSE WHEN ELECTRICITY TO THE UNIT IS INTERRUPTED WHILE BURNING OR SMOLDERING FUEL REMAINS IN THE BURN GRATE. (*See “Battery Backup” on page 14*)

2. It is not recommended to run vertical venting outside the heated environment where the Stove is installed. Running a venting system in a cold environment may cause the flue temperatures to cool down too much for adequate drafting.

Additional vertical exhaust venting should be provided when using:

a. More than one (1) elbow or tee; and/or

b. Horizontal runs of over three (3) feet. (*Horizontal runs over 10 feet not recommended*)

3. For a venting system ending in a horizontal run, the exhaust pipe must be terminated by a listed end cap or a PL vent elbow (45 or 90 degrees). Note: End caps or elbows must vent exhaust gases away from the building.

4. For termination above the building roofline a rain cap is required.

5. The exhaust pipe on the Lincoln SCR is 4” O.D. to accommodate a pipe adaptor.

## VENTING: TERMINATION REQUIREMENTS

In determining optimum vent termination, carefully evaluate external conditions, especially when venting directly through a wall. Since you must deal with odors, gases, and fly ash, consider aesthetics, prevailing winds, distances from air inlets and combustibles, location of adjacent structures and any code requirements.

1. Exhaust must terminate above combustion air inlet elevation.
2. Do not terminate vent in any enclosed or semi-enclosed area, (i.e. carports, garage, attic crawl space, etc.) or any location that can build up a concentration of fumes.
3. Vent surfaces can get hot enough to cause burns if touched by children. Non-combustible shielding or guards may be required

**The type of installation must first be considered before determining the exact location of the venting termination in relationship to doors, window, cavities or air vents. See figures 8a and 8b below.**

- a. **Without** Outside Air connected to the unit. For These types of installations please refer to the dimensions listed below in figure 8a.

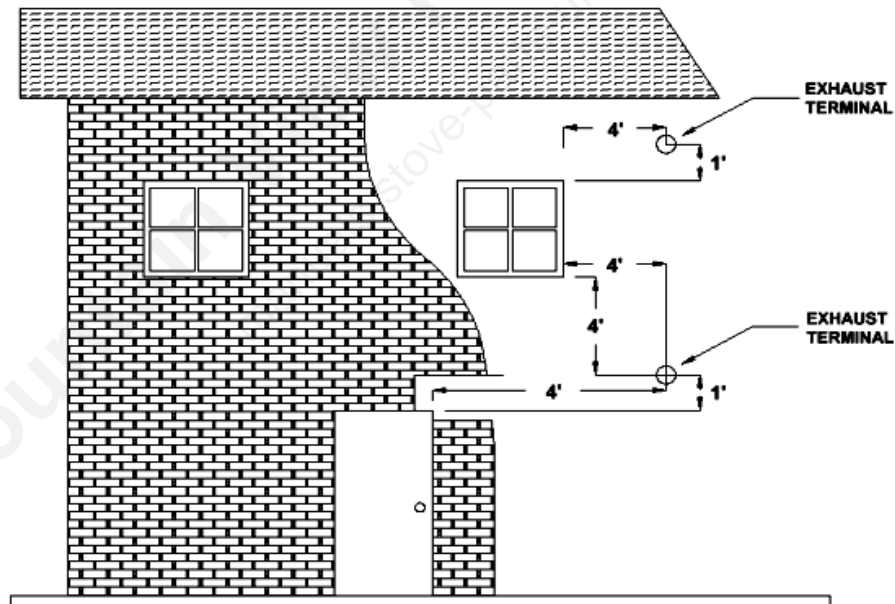

Figure 8a

- 4' (1.2 m) BELOW .....a door, window, cavity, or air vent
- Or
- 4' (1.2 m) HORIZONTALLY FROM..... a door, window, cavity, or air vent
- Or
- 1' (305 mm) ABOVE.....a door, window, cavity, or air vent

- b. **With** Outside Air Connected to the unit. In this manner the appliance is a Direct Vent Appliance (sealed Combustion System) as listed in NFPA 211-6.

3.3.3.2 *Direct Vent Appliance (Sealed Combustion System Appliance)* A system consisting of an appliance, combustion air and flue gas connections between the appliance and the outside atmosphere, and a vent cap supplied by the manufacturer, and constructed so that all the air for combustion is obtained from the outside atmosphere and all flue gases are discharged to the outside atmosphere.

Special Venting Arrangements are listed in NFPA 211-31

10.7.1.2 *The Vent Terminal of a Direct Vent Appliance with an input of 10000 BTU/Hr or less shall be located at least 6" from any opening into a building, and such an appliance with an input of over 10000 BTU/Hr, but not over 50000 BTU/Hr shall not be located less than 9" from any opening through which vent gases could enter a building, and the vent terminal of such appliance with an input over 50000 BTU/Hr shall be located not less than 12" from the opening.*

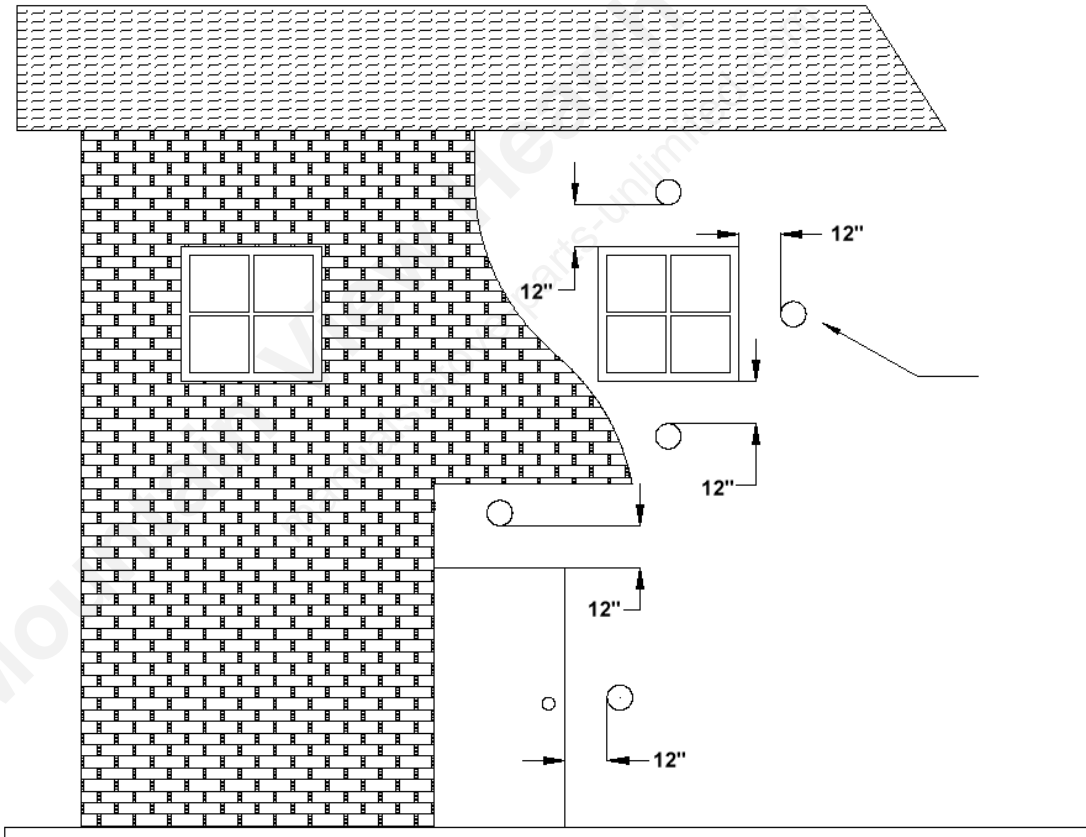

Figure 8b

- 1' (305 mm) ABOVE..... a door, window, cavity, or air vent.
- 1' (305 mm) BELOW ..... a door, window, cavity, or air vent.
- 1' (305 mm) HORIZONTALLY ..... a door, window, cavity, or air vent.

## VENTING: TERMINATION CLEARANCE REQUIREMENTS

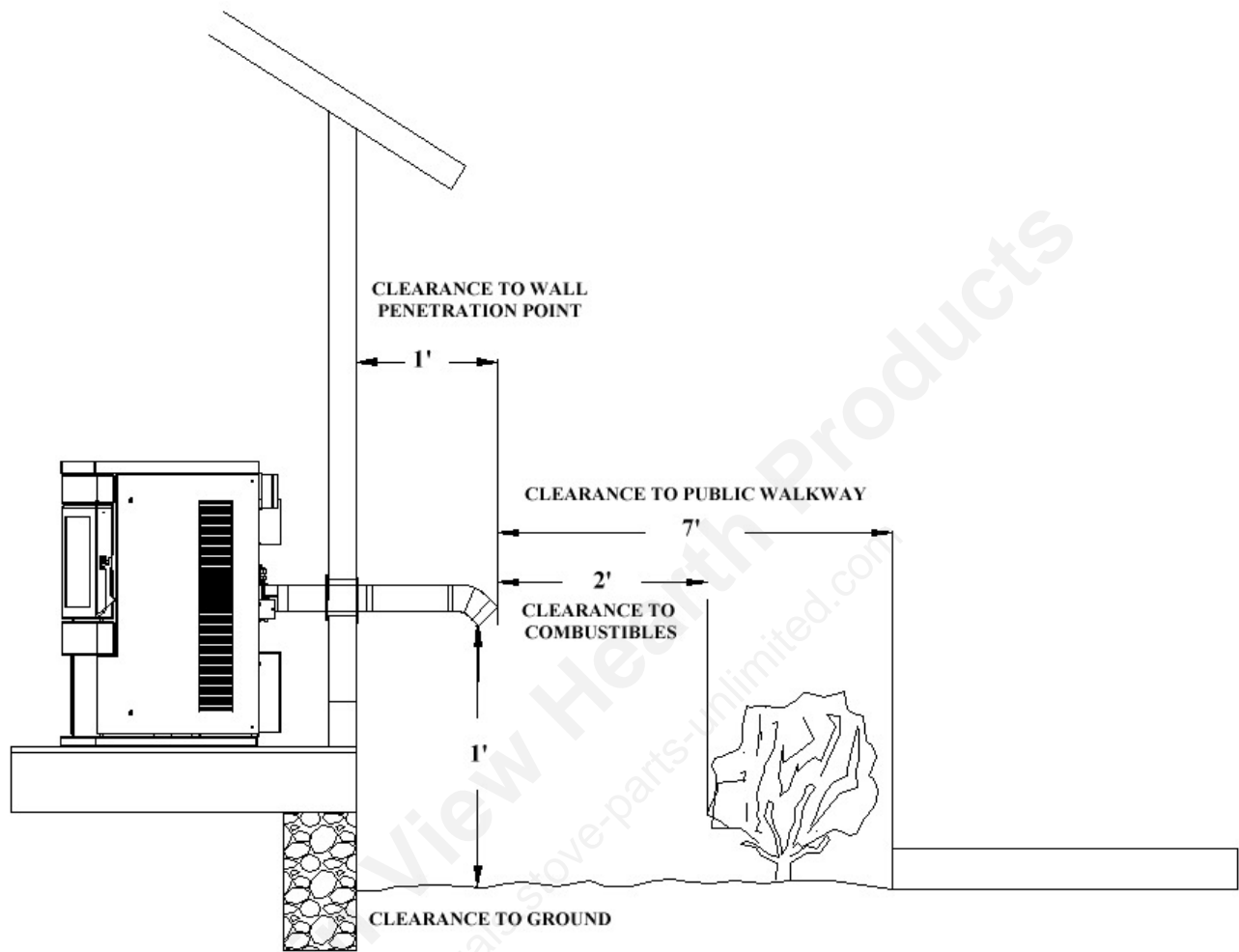

Figure 9

THE EXHAUST TERMINATION LOCATION MUST BE AT LEAST

- 1' (305 mm) .....ABOVE the ground level
- 7' (2.1 m) .....FROM a public walkway
- 1' (305 mm) .....FROM The wall penetration point
- 3' (915mm) .....FROM a gas meter/regulator assembly
- 2' (610 mm) .....FROM any adjacent combustibles such as:  
Adjacent buildings, fences, protrude parts  
of the structure, roof eaves or overhangs,  
plants or shrubs, etc.

## VENTING: INTO AN EXISTING CHIMNEY

The stove may be connected to an existing Class A chimney or a masonry chimney which meets the minimum requirements of NFPA 211.

1. If the stove's exhaust is connected to a masonry chimney, the masonry chimney must be free of cracks that could leak exhaust gases or fly ash. A relining of the chimney with either PL vent or single wall stainless steel pipe may be necessary to bring the chimney into compliance.
2. When chimneys are relined, a chimney chase cap that reduces the outlet of the chimney to the size of the liner is required. Extend the exhaust vent above the chimney chase cap and finish it off with a rain cap. **A single wall liner may need to be insulated to maintain adequate exhaust temperatures in the vent system** Note: Outside Chimneys frequently are difficult to keep warm, if in doubt insulate the liner.

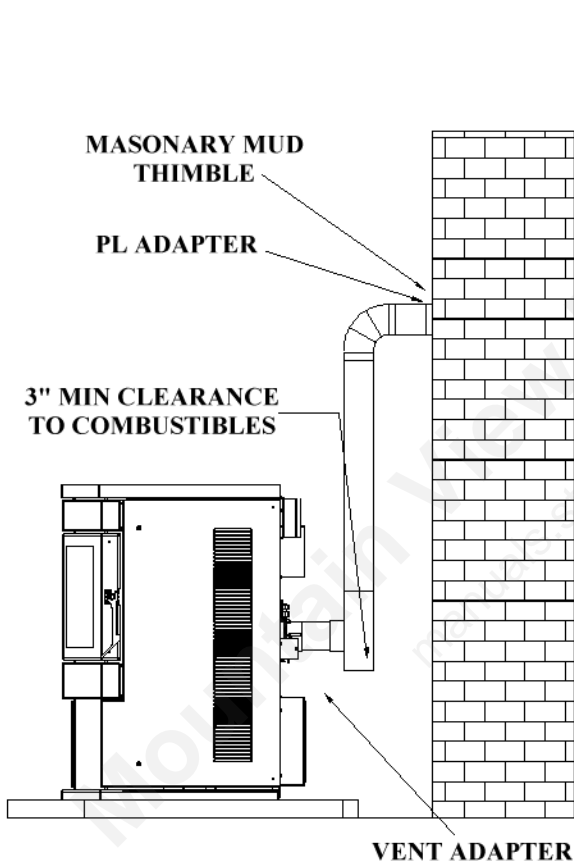

Figure 10  
Venting into Masonry Chimney

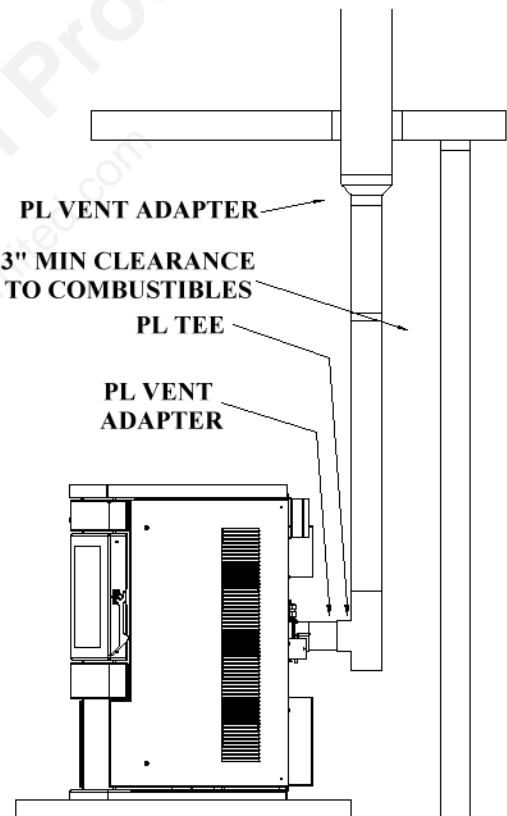
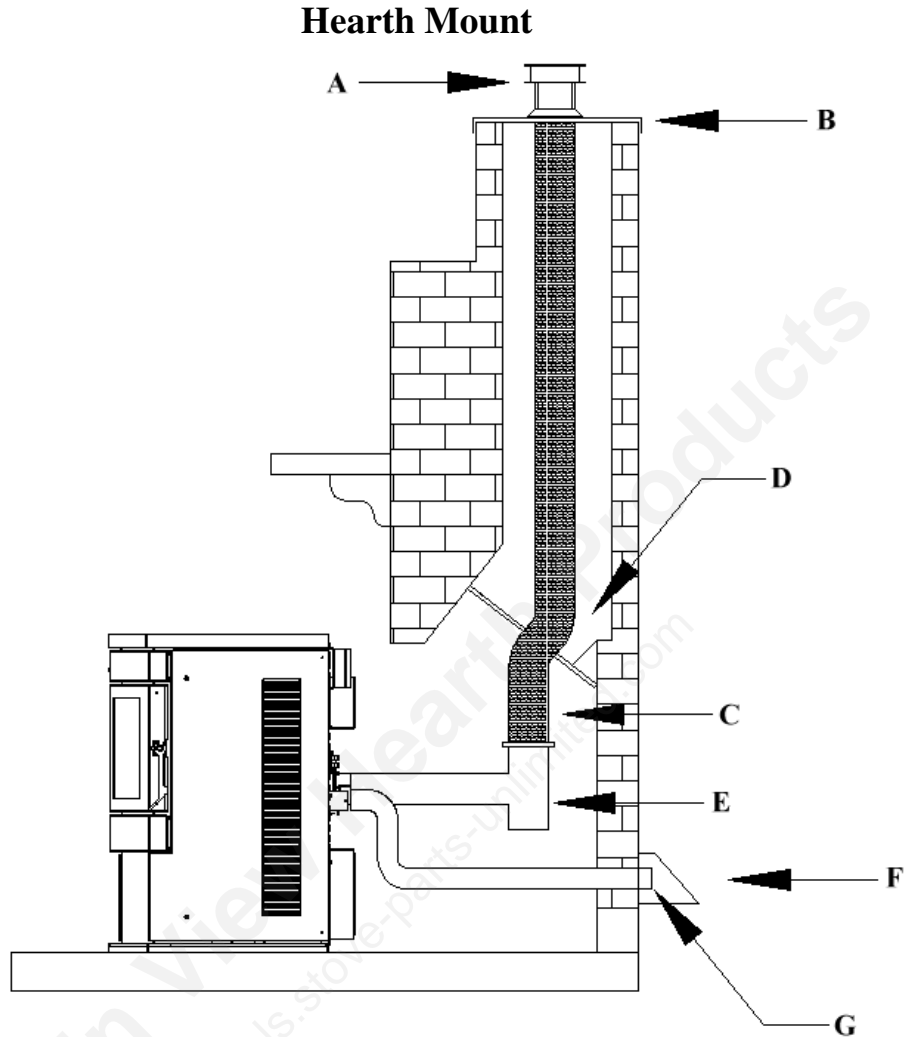

Figure 11  
Venting into Class A Chimney

3. Venting into the side of an existing masonry chimney must be done through a masonry thimble. When wall penetration is necessary to access a masonry chimney, use a listed PL vent wall thimble. (Figure 10).
4. When venting into a Class A steel chimney, (Figure 11), use an appropriate PL Vent adapter.



#### Legend

- A – Vertical Cap
- B – Chimney Flashing
- C – Stainless Steel Liner / PL Vent System
- D – Positive Block Off Plate
- E – PL Tee or Single Wall Tee
- F – Outside Air Shield – May be needed
- G – 2" Metal Outside Air Pipe - Optional

Figure 12  
Venting to the Top of Chimney

When installing as a hearth mount stove into a fireplace, the unit must either be relined terminating above the chimney chase top, or positively connected to the existing chimney system using a block off plate (D). **An approved flex liner of PL vent must be used. A chimney system with known drafting problems may require a liner, which may also need to be insulated to keep vent system warm in a cold chimney environment.**

## FLOOR PROTECTION

The stove must be installed on a non-combustible protective pad

Hearth models may be placed directly on the noncombustible hearth of a fireplace.

The Hearth must extend a minimum of 6" (152 mm) in Front of Unit *and* beyond each side of the Fuel Loading and Ash Removal Opening(s).

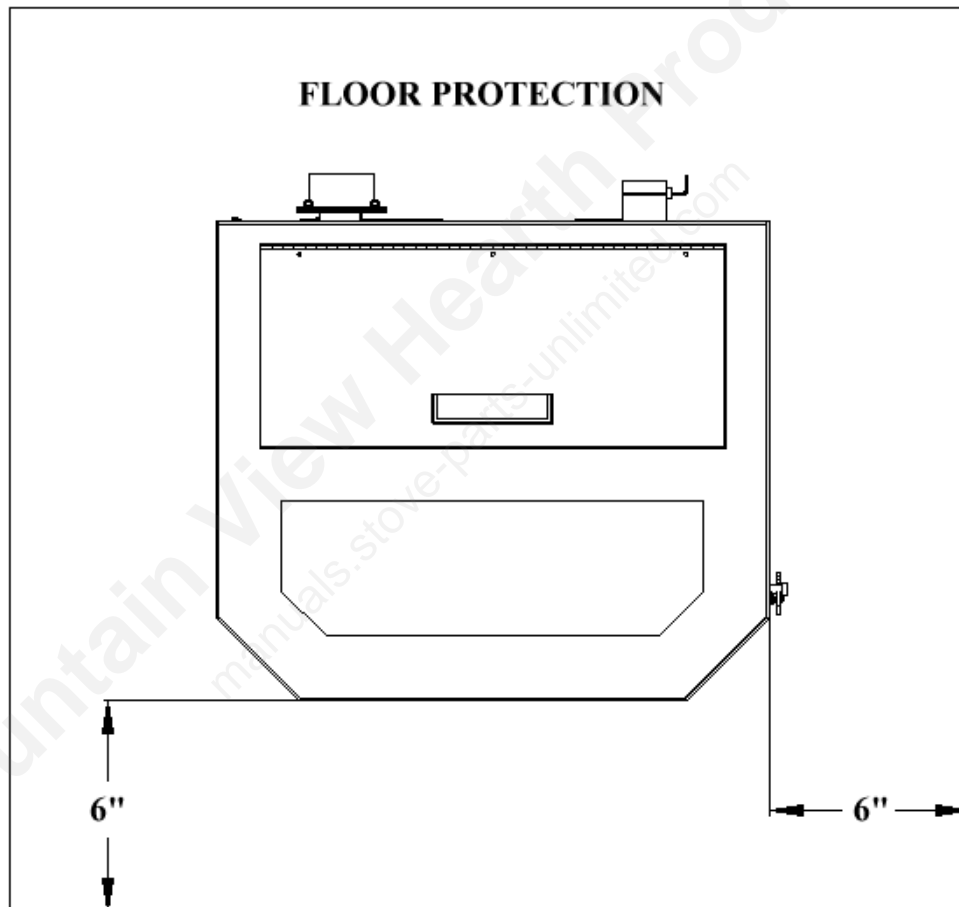

Figure 13  
Floor protection  
(Top View)

## MINIMUM CLEARANCES (INCHES) TO COMBUSTIBLE MATERIAL

Figure(s):	From:	
11.....	Sides of stove.....	6"
11.....	Back of stove.....	4"
10.....	Corner of stove.....	4"
6, 7.....	Vent pipe.....	3"
12.....	Stove to mantel.....	12"
9, 12.....	Floor protection: Front (from faceplate).....	6"
9.....	Floor protection: Sides.....	6"
13.....	Alcove: Vertical to Combustibles.....	16"
14.....	Alcove: Sides.....	6"
14.....	Alcove: Back.....	4"

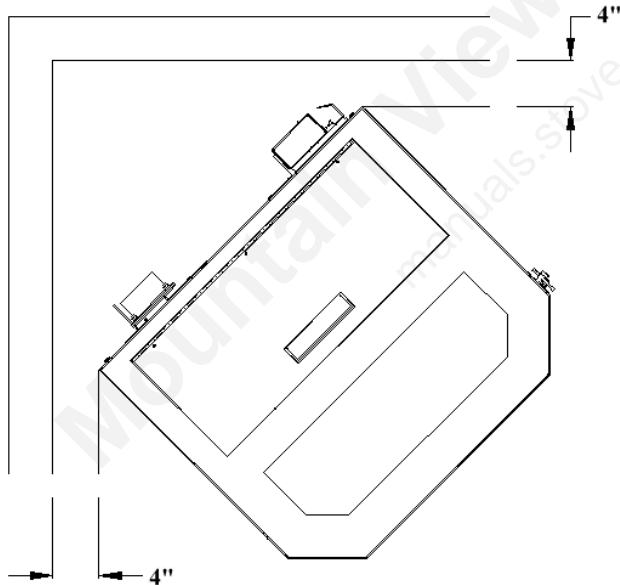

Figure 14 (Top View)  
Clearances: corners of stove

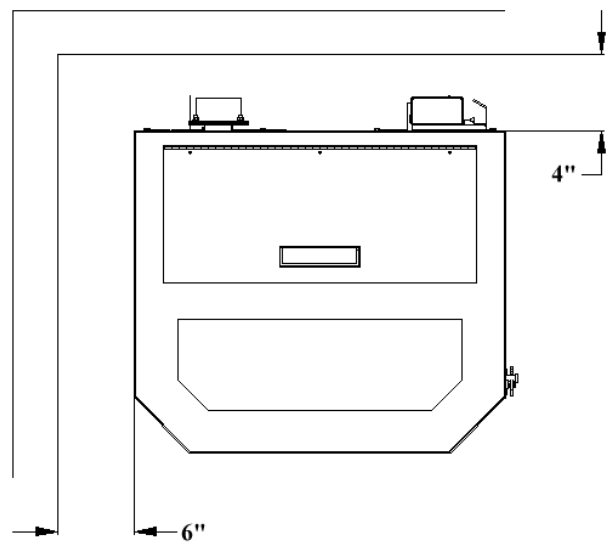
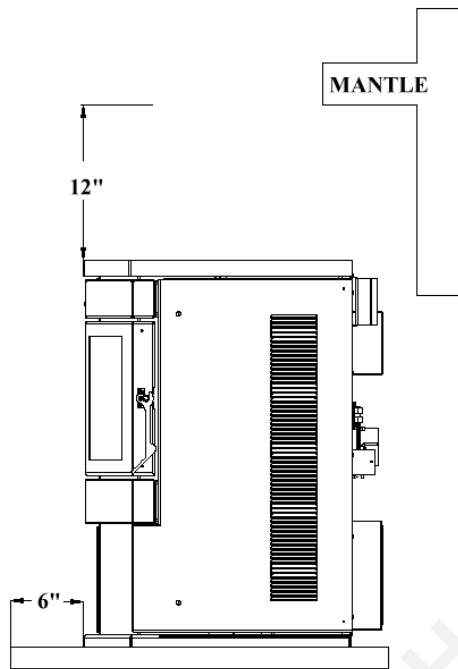
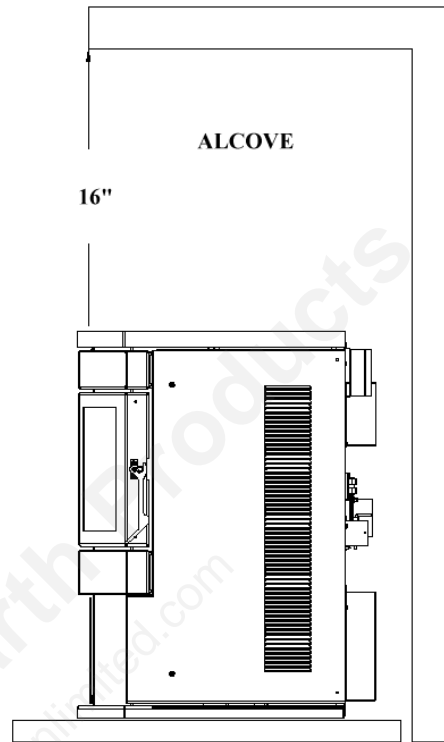

Figure 15 (Top View)  
Clearances Sides and Back



Floor Pad and Mantle Clearances  
Figure 16



Alcove Installation (Side View)  
Figure 17

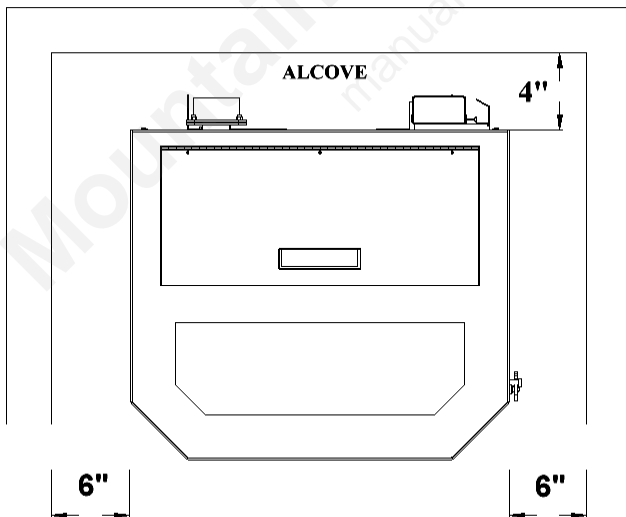

Figure 18  
Alcove Installation (Top View)

Although 6" is the minimum clearance to the sides of the stove, this is not recommended due to the need for access into the inside of the stove for the maintenance, as spelled out in the Operations Manual. Please read the section covering Daily, Periodic and Yearly Maintenance in the Operations Manual.

## OUTSIDE COMBUSTION AIR

1. Under certain conditions it is recommended that the Lincoln SCR be connected to an outside source of combustion air to improve performance. Flexible metal hose, or rigid metal pipe, (conduit), must be connected around (NOT INSIDE) the combustion air inlet tube, which may be terminated flush with the outside wall but should be protected from wind and weather by a hood. Be careful not to pinch or bend the outside air pipe with too small a radius. Note: The outside air pipe must terminate above the maximum snow line.

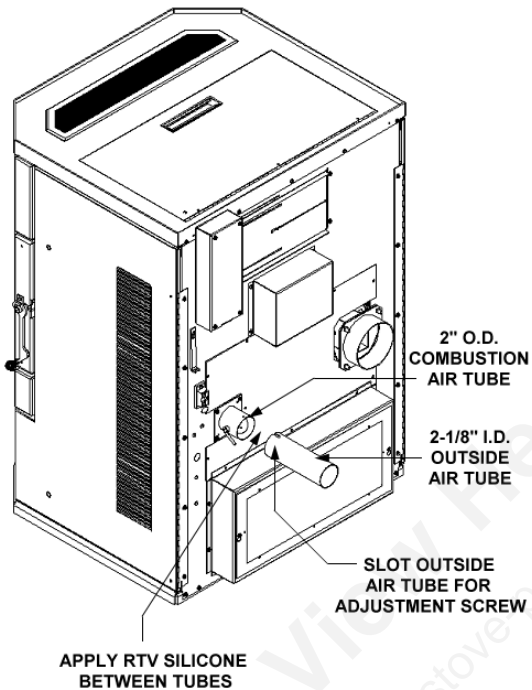

Figure 19

**WARNING**

**USE THE AIR INTAKE DAMPER FOR ADJUSTING COMBUSTION INLET AIR ONLY! OTHER METHODS OF RESTRICTING OR BLOCKING COMBUSTION INLET AIR ARE STRICTLY PROHIBITED!**

2. Outside air may be drawn from a semi-enclosed attic or crawl space or any semi-enclosed space. Take care not to draw cold air past water pipes that may freeze.
3. Increase the outside air pipe diameter to 3" for runs over ten (10) feet and elevation over 4,000 feet. Note: Long runs should be avoided.
4. Terminate the outside air pipe below the exhaust vent outlet.
5. An open mesh screen should be placed over the outside air pipe opening to prevent birds or rodents from nesting in the opening. Use an elbow or shield to prevent prevailing winds from blowing directly into the outside air intake pipe. NOTE: Mesh screen should be no smaller than one-fourth inch (1/4") by one-fourth inch (1/4").

**WARNING: OUTSIDE COMBUSTION AIR IS REQUIRED FOR ALL MOBILE HOME INSTALLATIONS!**

# Mobile Home Installation

Unit must be installed in accordance with the:  
Manufactured Home and Safety Standard (HUD), CFR 3280, Part 24

Unit may be installed in a Mobile Home, after the initial sale of the Mobile Home, not for Recreational Vehicles.

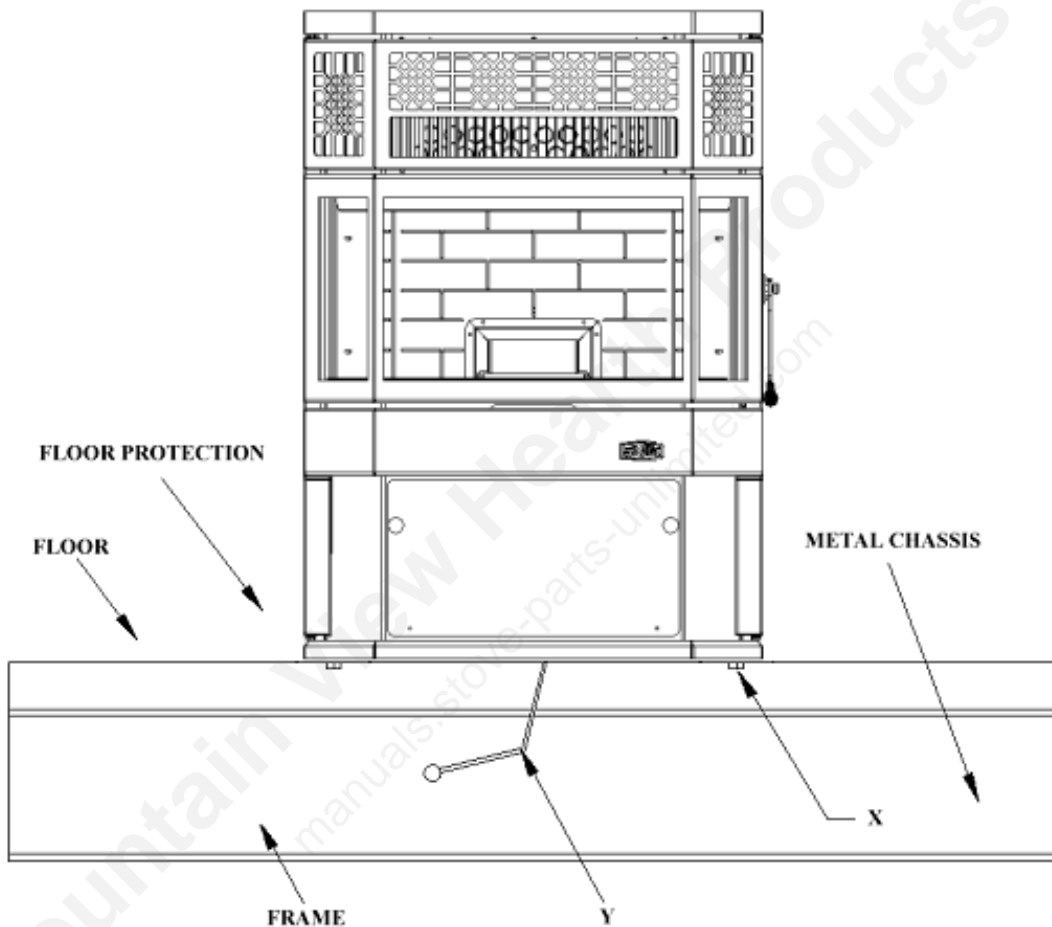

Figure 20

**1. WARNING: DO NOT INSTALL IN A SLEEPING ROOM.**

**2. WARNING: COMBUSTION AIR MUST COME FROM THE OUTSIDE OF THE MOBILE HOME! FAILURE TO DO SO MAY CREATE NEGATIVE PRESSURE WITHIN THE MOBILE HOME AND COULD DISRUPT PROPER VENTING AND OPERATION OF THE PELLET STOVE.**

**3. CAUTION: THE STRUCTURAL INTEGRITY OF THE FLOORS, WALLS, CEILING AND ROOF MUST BE MAINTAINED.**

4. Permanently bolt the stove to the floor, (X).
5. Electrically ground the stove and pedestal to the metal chassis of the home. Use a number eight, (8) gauge or larger copper wire, (Y).
6. Maintain an effective vapor barrier at location where PL vent exits the structure.
7. Check any other local building codes or other codes that may apply.
8. Do not use components other than those specified for use with this unit.
9. Floor protection requirement must be followed precisely.
10. PL Vent must be used for exhaust venting. (Single wall vent is not allowed). Follow PL Vent manufacturer's installation directions and observe all listed clearances to combustibles.

### USE OF A THERMOSTAT

St. Croix Pellet stoves offer our customers the optional feature of thermostatically controlling your new stove. By using a thermostat to control the operation of your Stove, you can benefit two ways. First of all, after setting the thermostat to your desired heating needs the stove will operate accordingly to uniformly maintain your desired temperature setting. Secondly, the fuel consumption is being optimized, which ultimately results in lowering your seasonal heating costs.

While the room temperature remains cooler than your desired thermostat setting, the stove will operate at any of the 5 HEAT ADJUST selector positions. Read the Operations manual to determine which Thermostat Mode you want to use. You can choose between the T-Stat Mode and the SmartStat Mode. *We recommend using the Fully Automatic "SmartStat" Mode.*

1. Once you have successfully lit your stove, set the thermostat to your desired heating needs.
2. Set the HEAT ADJUST selector to a position that will effectively create a rise in room temperature above your thermostat setting. The recommended heat settings while using a thermostat are any position between 2 through 5.

### Thermostat Hook-up

Connect the wires from the thermostat to the external wire terminal on the back of the stove (see figure 21 on the following page).

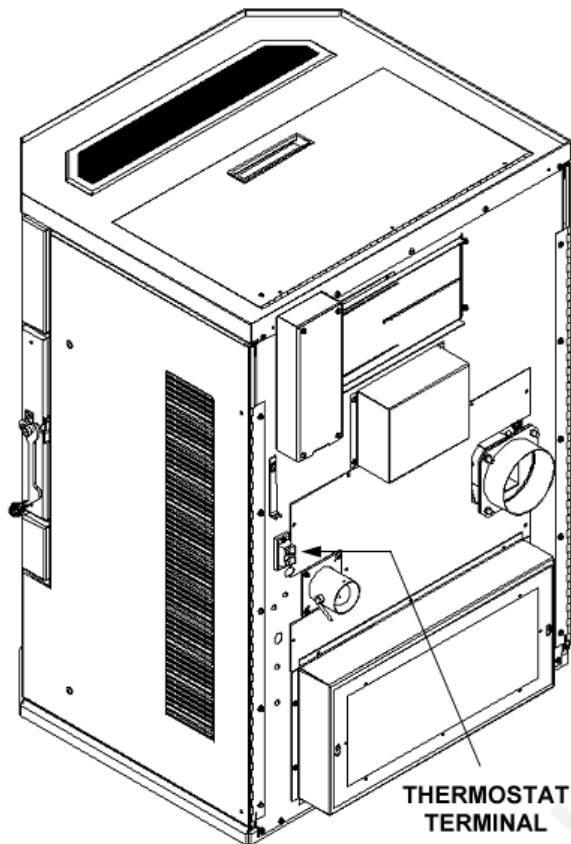

Figure 21

The external Thermostat wire terminal has been pre-wired to the thermostat wire Terminal on the back of the control board (See figure 22)

Read Frequently Asked Questions section in the Operations Manual to Troubleshoot the Thermostat.

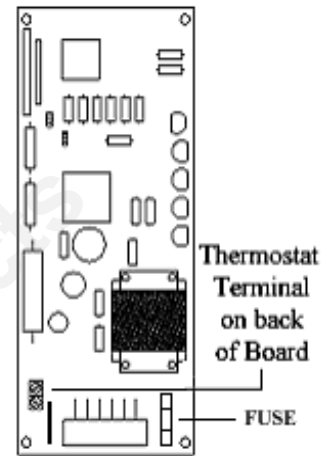

Figure 22

**NOTE: Installers must determine a neutral location of where to mount the thermostat panel for accurate room temperature measurements.**

## LINCOLN SCR OPERATION

**CAUTION: Operate this unit only with the fuel hopper lid closed. Failure to do so may result in emission of products of combustion from the hopper under certain conditions. Maintain hopper seal in good condition. Hopper lid switch will prevent the auger from running if lid is left open.**

This unit requires 120-volt AC power to operate. In the event of a power failure the unit will shut down. **DO NOT ATTEMPT TO RUN THE UNIT DURING A POWER FAILURE.**

### INSTALLATION CHECK

Proper installation is essential for safety, effective Operation, Warranty Coverage, Insurance requirements and to meet Local Building Codes. Installation Requirements are described in the first section of this manual. Verify the installation is correct before firing up the Stove for the first time.

When burning Corn, Wheat, Rye or Distiller's Grain, care should be taken in how the venting system is installed. To burn these fuels the moisture content should be 15% or less. This is much higher than the moisture content of wood pellets and can result in condensation forming in the venting system in certain installations. The chimney system should stay within the warm envelope of the house as much as possible. Only penetrate the exterior of the home where the exhaust system will terminate.

**REMEMBER: Condensation from a corn Stove is detrimental to the venting system. Only buy venting systems that are warranted with burning corn.**

## **PREVENTING CHIMNEY FIRES**

Chimney fires can be prevented by properly operating the Stove and by periodic inspection and cleaning of the chimney. When wood is burned it produces tar and other organic vapors, which combine with expelled moisture to form creosote. The creosote vapors condense in the relatively cool chimney flue associated with a slow burning fire. As a result, creosote residue accumulates on the flue lining and when ignited this creosote can result in an extremely hot chimney fire.

The chimney and chimney connector should be inspected at least once every two months during the heating season to determine if a creosote build-up has occurred. If a significant layer of creosote has accumulated (3 mm or more) it should be removed to reduce the risk of a chimney fire. Use of an appropriately sized chimney brush or the services of a professional chimney sweep are recommended. Also check to make sure the system is not getting plugged with fly ash. Remove the Fly Ash if needed. Use of an appropriately sized chimney brush or the services of a professional chimney sweep are recommended.

**APPROVED FUELS-Pellets, Corn, Wheat, Rye, Cherry Pits & Distiller's Grain only**

### **PELLETS & CHERRY PITS**

Clinkers and Ash are by-products of pellet & cherry pit combustion and are not caused solely by your Stove. Stove performance can be quickly and severely reduced if poor quality fuel is used. **Contact your dealer for more information on APFI approved wood pellet fuels. No standard exists for cherry pits.**

**NOTE:** Pellets with excessive sawdust should be screened by sifting with a 1/4" mesh screen.

Store Pellets under cover on a wooden pallet or other methods to ensure they do not become rain soaked or absorb moisture from damp or wet floors. Do not store pellets within Stove installation clearances or within the space required for ash removal.

### **CORN, WHEAT, RYE, DISTILLER'S GRAIN**

These grains must have a 15% or less moisture content. The keys to satisfactory performance are: proper operation of the stove, diligent maintenance and burning only dry, clean, quality corn, wheat, rye & Distiller's Grain.

**NOTE: Corn, Wheat, Rye & Distiller's Grain with excessive grain dust must be screened, by sifting with the appropriate size mesh screening. Large pieces of cob may plug the auger. No Standards exists for these fuels. Inspect fuel before buying.**

Store grain in a tight container or use other methods to ensure it does not become rain soaked or absorb moisture from damp or wet floors. This will also prevent rodents from becoming a problem. Do not store corn within Stove installation clearances or within the space required for clinker/ash removal.

**The Revolution Burn System** was specifically developed to burn most grades of pellets and many other biomass fuels, such as Corn, Wheat, Rye & Distillers Grain pellets. When burning these fuels the Revolution pot is designed to cut the clinkers that form in the rotating drum. More and more pellets are also being produced with higher ash content than is allowed in a Premium Pellet. This requires a design that is capable of handling the ash produced in lower grade fuels. The Revolution Burnpot consists of a rotating drum that is divided into 4 sections. The drum is rotated on timed intervals to empty ash and keeps the pot burning at optimum efficiency. This eliminates the need to frequently shut the unit down for maintenance. Read the section covering Daily, Periodic and Yearly Maintenance for proper Maintenance Schedules.

**The Stove is not warranted against damage caused by using poor pellets or other fuels not approved for use in this Stove, incorrect operation, improper maintenance, or incorrect installation.**

## *St Croix SmartScan Maintenance System*

Patent Pending

**“Pre-emptive Monitoring”** is an innovative way of detecting when the unit is burning incorrectly.

The following situations can affect the way a Pellet Stove burns:

***Operator Error, Poor Fuel Quality, Plugged Venting System, Plugged Stove, Dirty Burn Pot, Worn Door Gaskets, Worn Glass Gaskets or Weak Combustion Fan.***

***How does it work?*** - The area monitored is ***inside the Firebox/Burnpot*** area, directly above the back edge of the burn pot.

*The SmartScan Infra Red sensing system is very accurate. The monitoring takes place from a remote location, which can sense an object as small as **one pellet** and does not depend on sensing temperatures. Temperature sensing is difficult at this location, because it monitors an area that fluctuates between extremely hot temperatures during High Burn and temperatures that aren't as hot in the burn pot during Low Burn.*

By monitoring this area, the stove will shut down when conditions in the Burn Pot fall outside of the Normal Operating range. Shutting the unit down when fuel reaches this level, will trigger a diagnostic code that notifies the operator of the stove that the stove needs maintenance. The above list is intended as a guide to determine where the problem may be.

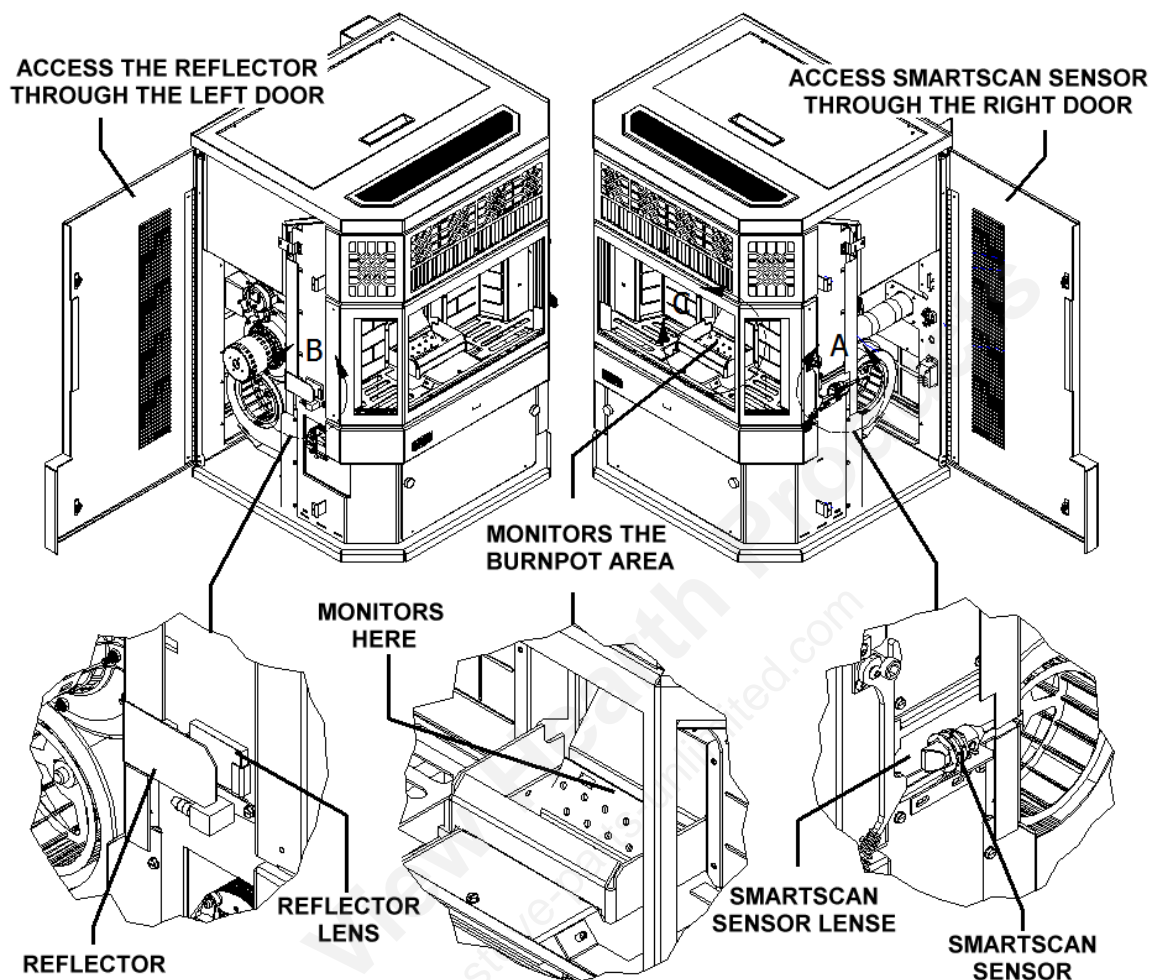

Figure 23

Figure 23 shows the location of the SmartScan components. Opening the right side door will give you access to the Infra Red Sensor and the viewing lens on that side of the stove. With the stove plugged in you know the unit is functioning when you see the small Yellow LED is on. This means the light beam is projected across the stove to the left side where the Reflector is located and reflected back to the sensor without any obstruction in between.

Occasional cleaning of the lens will be needed. The lens easily slides out of the bracket for cleaning. The sensor may also be cleaned, by gently wiping the lens of the sensor with a soft cloth. **Never clean the sensor using alcohol. Do not move the Sensor, this may knock the Sensor out of alignment.**

Opening the left side door will give you access to the Reflector and the viewing lens on that side of the stove. Occasional cleaning of the lens will be needed. The lens easily slides out of the bracket for cleaning. The Reflector may also be cleaned, by gently wiping the reflector with a soft cloth.

# The Revolution Burn System

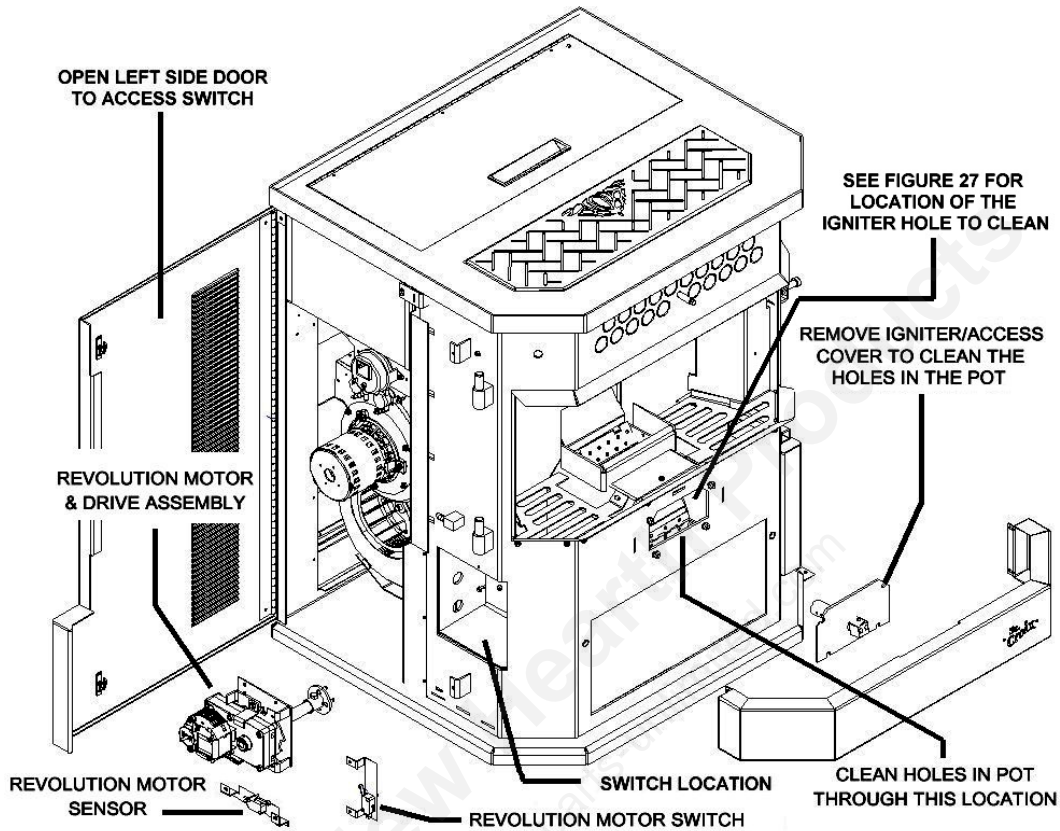

Figure 24

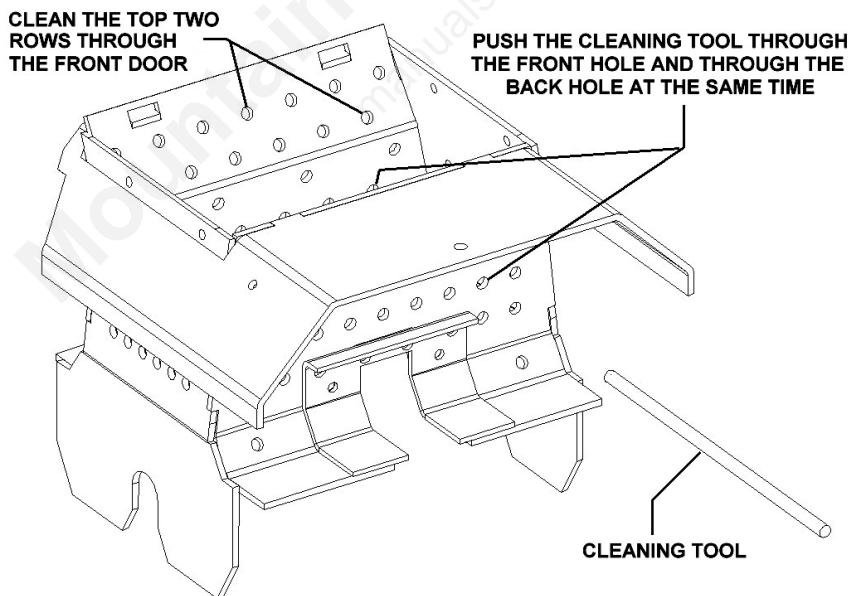

Figure 25

## Pot Clean-Out Access Cover

There is a cover in the front of the stove that gives access to cleaning the holes in the front and back of the Revolution burn pot. The holes should be checked periodically to keep the unit burning properly. For proper Ignition the hole in the front of the pot for the Igniter needs to be kept open. If a change is noticed in how the stove ignites, shut the unit down and clean the hole. See Figure 25 to the left for more information.

To clean the holes in the burnpot use a 3/16" diameter rod or a long Phillips Screw Driver (should be a minimum of 12" long) to reach the holes on the back side of the pot. Simply insert the cleaning tool through one of the front holes and push it all the way through and clean the hole that lines up behind it at the same time. (See Figure 25 on the previous page.)

## Revolution Multi-Fuel Pot - Removal

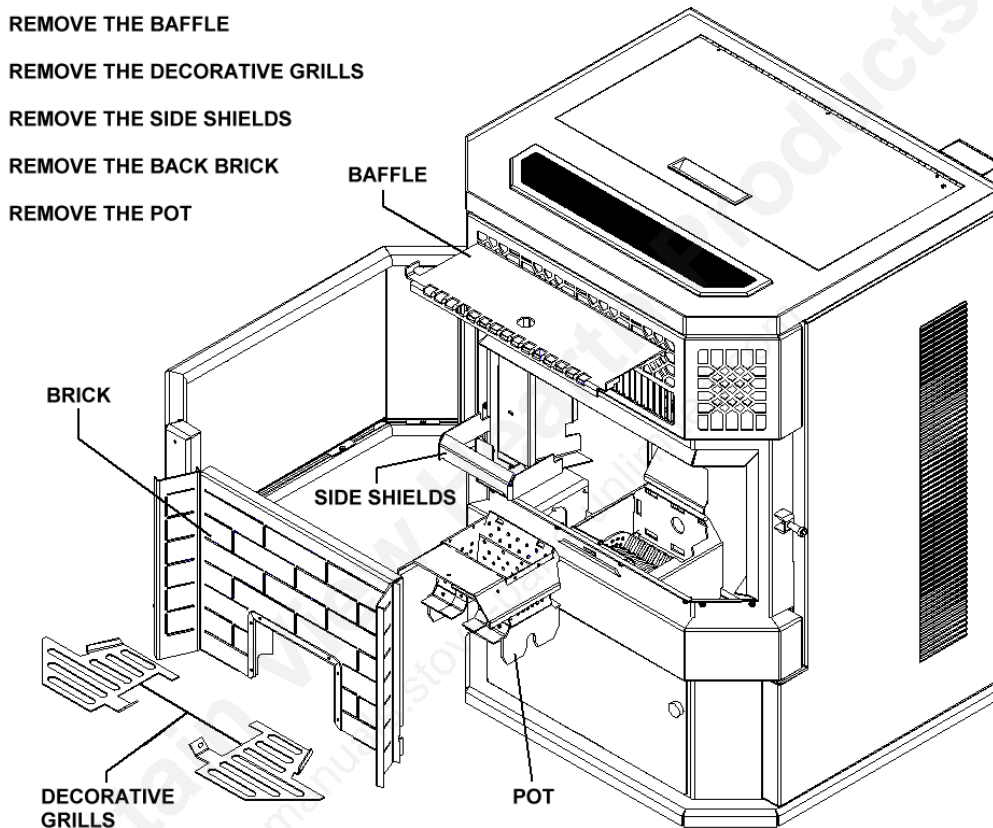

Figure 26

Figure 26 shows in more detail how the pot is removed from the stove for cleaning. The pot should not need to be removed for cleaning if the method is used shown in figures 24 and 25 using a cleaning tool. Try cleaning the pot using both methods to become more familiar with your stove. The Revolution pot design has been changed in this model to make it easier to remove without having to remove the Gearmotor and the Switches that control the drum.

Figure 27 on the following page will show how the Clinker Cutter and the Drum are removed from the stove. Unless the Drum has become jammed on a foreign object, these components should not need to be removed from the unit.

# Revolution Multi-Fuel Pot – Exploded View

(Certain parts that obstruct the view of these components have been removed for a clearer picture)

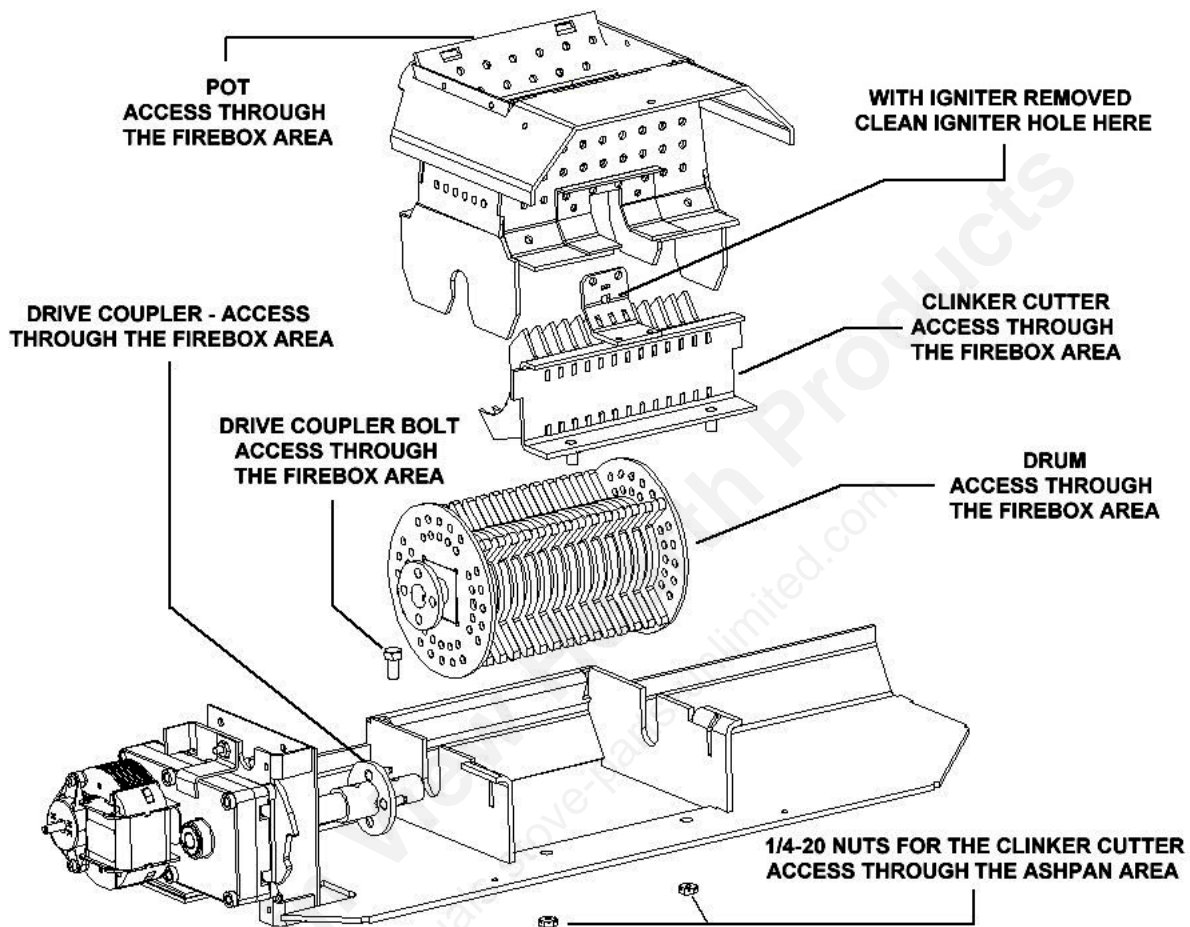

Figure 27

The main components of the Revolution Pot are:

- The Pot Weldment
- The Revolving Drum, which is the bottom of the burnpot.
- The Clinker Cutters

To remove the components shown in figure 27:

1. First remove the pot as shown in figure 26.
2. Disengage the Drive Coupler by sliding it away from the Drum.
3. Lift the drum out of the stove.
4. Remove the 2 1/4-20 nuts that hold the Clinker Cutter in place.
5. Lift the Clinker Cutter out of the slots that position it in the stove.

To re-assemble the Pot Assembly reverse the steps above. (Be sure to place the drum with the drive coupling facing the Revolution gear motor.)

# The Dual Hopper

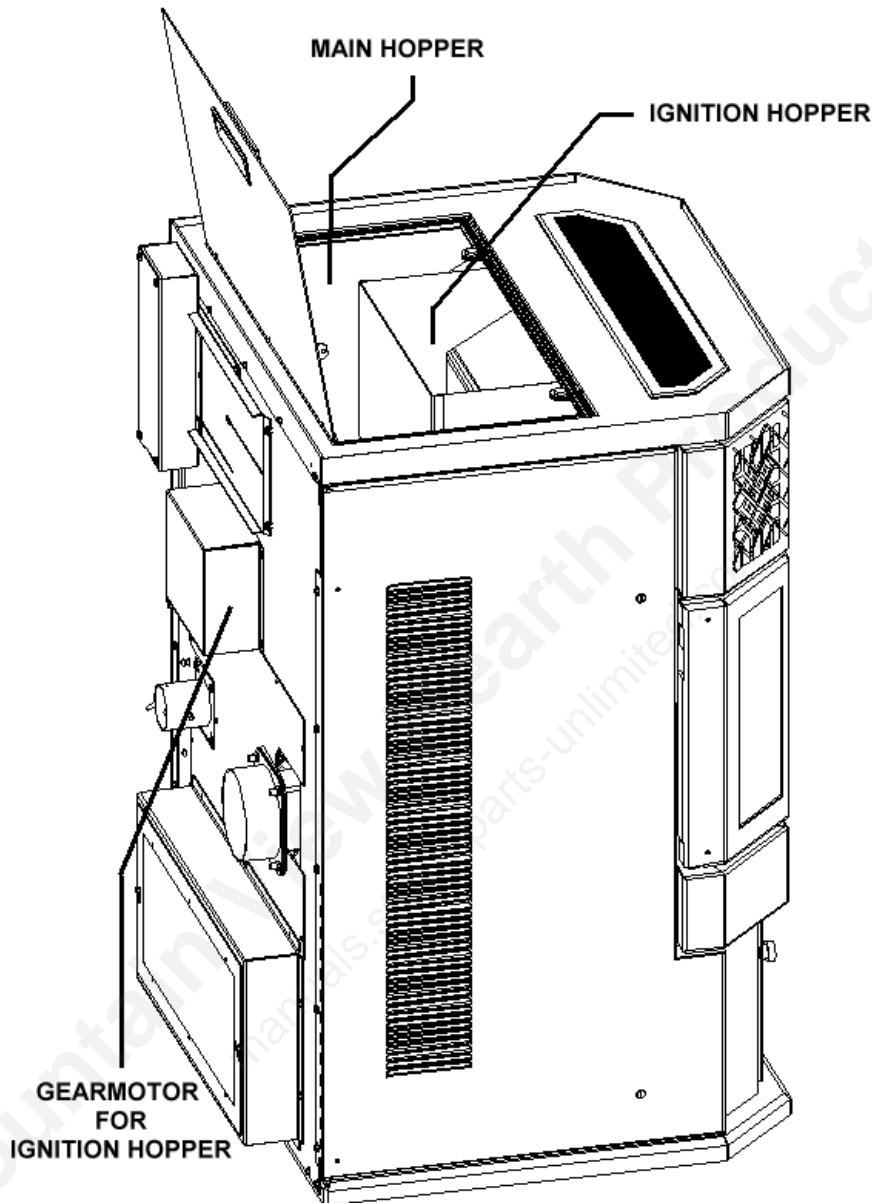

Figure 28

The Multi-Fuel Revolution pot used in the Lincoln SCR uses a Dual Hopper (See Figure 28). The Ignition Hopper is a Patent Pending Ignition System using pellets to ignite the Stove and automatically switch over to Corn, Wheat, Rye, Cherry Pits or Distiller's Grain after ignition has taken place. This allows the Stove to be fully automatic running on a thermostat when burning fuels other than Pellets. Figure 28 shows the small pellet hopper and gear motor used during the ignition process.

FOLLOW THESE OPERATING INSTRUCTIONS EXACTLY AS STATED TO ENSURE SAFE AND RELIABLE OPERATION.

1. Carefully read this “Operation and Maintenance” manual in its entirety BEFORE lighting your Stove for the first time.
2. Obtain final inspection and approval of installation from local building officials.
3. Have your dealer demonstrate all the operational and maintenance steps necessary for proper use of the Stove. **Sign and return the warranty card** to the address listed on the back page.
4. Some odors may be given off during the first few hours of burning during initial break-in. These odors are normal and not harmful. However, ventilating the room until the odors disappear is recommended.
5. The Stove will become HOT while in operation. Keep children, clothing and furniture away from all hot surfaces.

**WARNING: Direct contact with the Stove firebox during operation may cause skin burns.**

6. To avoid the possibility of smoke and/or sparks entering the room always keep firebox and ash pan doors closed whenever the Stove is operating.
7. A certain amount of carbon monoxide may be produced within the Stove as a by-product of combustion. All exhaust vent connections must be sealed with **RTV silicone** to assure a gas tight seal. **Any leaks into a confined area caused by faulty installation or improper operation of the Stove could produce dizziness, nausea and in extreme cases, death.**
8. Under certain circumstances an outside source of combustion air may be needed and is required on all mobile home installations. If room air is used to supply combustion air, room air starvation (not enough make-up air), operation of exhaust fans and icing of air vents can adversely affect proper Stove operation.
9. Smoke detectors, installed in the same general area as the Stove, may be activated if the Stove door is left open and smoke is allowed to enter the area.

**CAUTION: NEVER ADD FIRE STARTER TO A HOT STOVE.**

**CAUTION - Hot Surfaces**

- **Keep Children away.**
- **Do not touch during Operation.**

## Control Board Features

The Control Board controls all functions of the Stove by monitoring sensors that are in the system. These sensors serve 2 purposes.

- a. General Operation of the Stove.
- b. Safety Features, to shut the unit down in the event the sensors detect a problem in the unit.

The Control Board also has Diagnostic Capabilities to help in diagnosing certain areas in the Stove. These areas are:

1. High Temperature Limit.
2. Proof of Fire Sensor
3. Vacuum in the Firebox
4. The Rotation of the Drum
5. The Fuel level in the Burn Pot

A closer look at the Control Board to the right in figure 29 will explain how the board works.

The ON/OFF button, The Auger Feed Button (used to prime the Pot with Fuel) and the **Heat Level** and **Draft Trim** Buttons. The last 2 buttons have High and Low buttons to advance/adjust these settings up or down. There is a slide switch that controls the Thermostat Mode and an LED Light bar that indicates which of the 5 Heat Settings the Stove is running on.

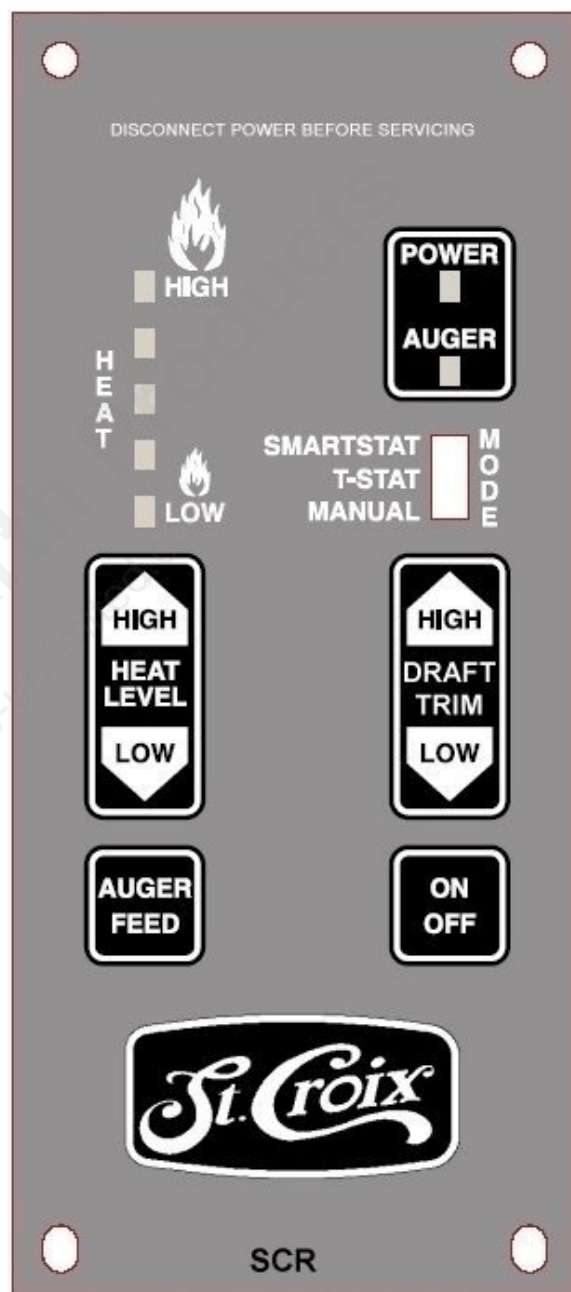

Figure 29

*The LED Light bar is also used during the Diagnostic process, see page 47 for more details.*

1. The Heat Level button will advance the setting up and down between level 1 and 5. It will also be used in the Fine Tuning process of the feed rates if needed. (See point 4 b. below)

2. The Auger Feed button will allow the user to manually auger fuel into the burn pot on start up when needed. This is particularly helpful in priming the Auger Tube when it is empty (After the hopper has run out of pellets). This button is also used to make small adjustments to the combustion air and the feed rates as part of the **Fine Tuning** process of the control board. (See point 10 on page 70)

3. The On/Off button not only turns the Stove On and Off, *it also resets the board if one of the sensors has detected a problem and the board is flashing a Diagnostic code.*

4. The Draft Trim button allows for adjusting the Exhaust (Combustion) fan voltages up or down providing for fine-tuning of the combustion air. The LED lights indicate the level of adjustment and the factory setting is the center LED light. This gives 2 adjustments up and 2 adjustments down. (See point 11 on page 70)

a. To adjust the Combustion Fan voltages:

Hold the Auger Feed button down and press the Draft Trim High/Low button and this will change the fan voltage approximately 2.5 volts up or down from the factory setting. Watch the LED lights to see the setting is on (it will flash the new setting). This new setting will stay in memory from this point on.

b. To adjust the Feed-rates:

Hold the Auger Feed Button down and press the Heat Level High/Low button and this will change the ON Time up or down .25 seconds from the factory setting. Watch the LED lights to see the setting is on (it will flash the new setting). This new setting will stay in memory from this point on.

5. The Thermostat Slide switch allows the Stove to be run in 3 different Modes:

a. Manual Mode. The Control Board controls all functions of the Stove.

b. T-Stat Mode. The Stove is hooked to a Thermostat and when calling for heat the Stove will advance to the Heat level set at the Control board. Once the Heat demand has been met the Stove will drop to the #1 Heat Level setting and pilot. The Stove never shuts off and provides constant heat. Stove must be turned ON/OFF at the control board.

c. SmartStat Mode. The Stove is hooked to a Thermostat and when calling for heat the Stove will advance to the Heat level set at the Control board. Once the Heat demand has been met the Stove will drop to the #1 Heat Level setting and pilot for one hour. If the Thermostat does not call for heat during that hour the Stove shuts off and re-lights itself the next time the Thermostat calls for heat. This is the Fully-Automatic Mode.

## Pre-Lighting Instructions.

The Control Board has 4 separate programs. Each program is specific to certain fuels. Before lighting the Stove for the first time, be sure the correct program is chosen.

To change the program on the board, the Stove must be off and plugged in. The programs are identical in operation, except for the Cycle Time. The Cycle time is the total of the ON Time & OFF Time added together. The ON Times are constant, so this means that the OFF Time is increased or decreased, depending on the program chosen.

The programs break down as follows:

- 1 - **Program 1.** The Cycle Time is 7.5 seconds. This program will be the default program when the Stove is first plugged in. **This program is for use with Pellets & Cherry Pits.** (See figure 32 on page 41)
- 2 - **Program 2.** The Cycle Time is 8.5 seconds. **This program is for use with Pellets, Cherry Pits & Corn.** (See figure 32 on page 41)
- 3 - **Program 3.** The Cycle Time is 9.5 seconds. **This program is for use with Pellets, Corn, Wheat, Rye, Cherry Pits & Distillers Grain Pellets.** (See figure 32 on page 41)
- 4 - **Program 4.** The Cycle Time is 10.5 seconds. **This program is for use with Pellets, Corn, Wheat, Rye, Cherry Pits & Distillers Grain Pellets.** (See figure 32 on page 41)

As the Cycle Time increases, the BTU rate of the stove decreases. Another way to look at it is this: burning pellets using program 1 will have a Higher BTU rating than pellets burning on programs 2 through 4. The same is true for burning corn, using program 2 will have a higher BTU rating than corn burning on programs 3 and 4. Looking at the list above you see which fuels are approved for any specific program. Using any of the other programs will cause the burnpot to overload. If the incorrect program is chosen for a specific fuel, the burnpot will overload and the Stove will loose its fire and go out.

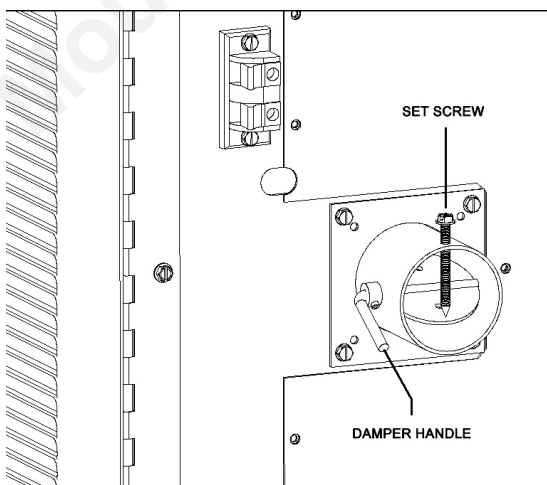

The damper must be adjusted for each specific fuel as well and should be set during the first fire.

To adjust the damper for other types of fuel, use the following procedures:

First turn the setscrew clockwise until it stops against the tube. See figure 30.

Figure 30

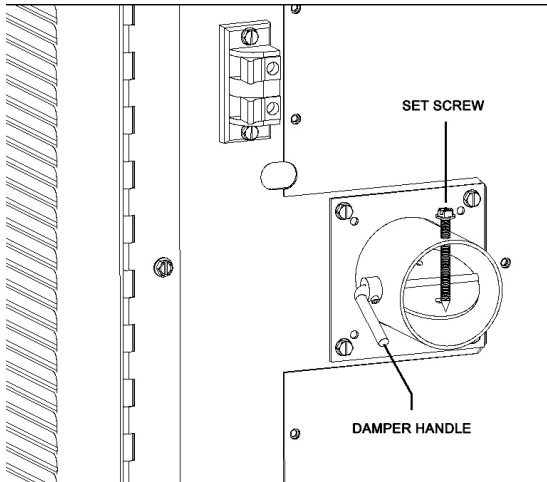

The factory setting is achieved by turning the screw in until it stops and then reversing the screw 5 full turns. **Remember to use the handle to place the damper against the screw.**

When switching between fuels it is best to return the Damper to the Factory Setting and then proceed to the setting listed below.

**Remember: The Settings listed below are the starting point for final adjustments to the damper and are for reference only.**

Figure 31

**Damper setting for Pellets, Cherry Pits & Distiller’s Grain** - Use the Factory Setting as the beginning point for final Damper Adjustments.

**Damper setting for Corn** - Turn the Screw in 1.5 turns from the Factory Setting and make sure the damper blade rests against the setscrew. *(This is reversing the screw a total of 3.5 full turns if the screw is turned in until it stops).* **Return to the Factory setting if you have difficulty starting the unit.**

**Damper setting for Wheat & Rye** - Turn the Screw in 3 turns from the Factory Setting and make sure the damper blade rests against the setscrew. *(This is reversing the screw a total of 2 full turns if the screw is turned in until it stops)* **Return to the Factory setting if you have difficulty starting the unit.**

**FOR MORE INFORMATION ON FINE-TUNING THE DAMPER SEE PAGES 43 - 46 “COMBUSTION AIR DAMPER”**

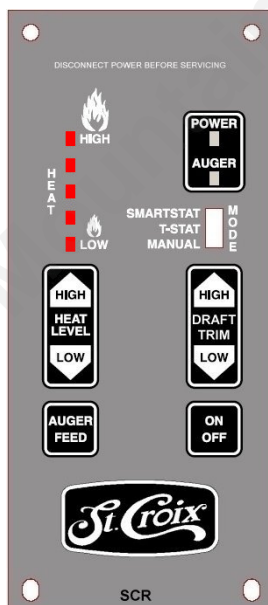

Figure 32

### Changing the Program on the Control Board

To change the program the Stove must be in the **OFF** position, the Stove must be **cooled down so the Proof of Fire switch is open** and the Thermostat slide switch must be in the **Manual mode**. (See Points 12 & 13 on Page 71)

**Press & hold** Auger Feed Button, then press & **release** the Draft Trim **High & Low** Buttons. The LED lights that indicate the heat level will flash. The number of times the lights Flash will indicate which program is running.

**Program 1 – LED lights flash once**

**Program 2 – LED lights flash twice**

**Program 3 –LED lights flash three times**

**Program 4 – LED lights flash four times**

## Lighting Your Stove.

### **WARNING: - Risk of Fire.**

- Do not operate with the Firebox door or Ash Removal doors open
- Do not store Fuel or other Combustible material within marked Installation Clearances.
- Inspect and Clean Flues and Chimneys regularly.

**Danger: Risk of Fire or Explosion - Do not burn Garbage, Gasoline, Drain Oil or other Flammable Liquids.**

**WARNING: The auger can start at any time while the Stove is running, this is a high torque motor that is capable of doing SERIOUS harm to fingers. Keep fingers and other objects away from the auger**

When lighting your Stove for the first time the auger tube will be empty, it helps to hold the “Auger Button” in until you hear fuel drop into the burn pot. Any of the approved listed fuels will be fed from the large hopper to the burn pot. The smaller hopper should only be filled with pellets to be used in the ignition process.

1. Make sure there is Fuel in the hopper.
2. Press the ON/OFF button once to turn on the Stove.

The Start up Program works as follows:

- a. The Combustion Fan comes on at high speed and the control board checks to make sure the Vacuum Switch locks in.
- b. When the board senses the Vacuum Switch the exhaust fan speed drops to the #1 setting, the Revolution burn pot will cycle to a clean section, pellets will start feeding from the small hopper for 2 minutes and the igniter comes on to ignite the pellets.
- c. After 2 minutes Continuous Feed it starts feeding pellets from the small hopper on the #1 setting for another 4 minutes.
- d. The stove will enter a 6 minute Wait Period to get the pellets burning
- e. The igniter runs for 8 minutes and shuts OFF.
- f. After the Wait Period finishes the unit resumes feeding pellets at the #1 level for 7 seven minutes. This completes the Ignition Cycle.
- g. If Proof of Fire has been reached the unit will enter “Normal Operation Mode”.

If the board still fails to sense the Proof of Fire switch the Stove will go into “Safety Shutdown” and Flash the #3 LED. (See section on Diagnostic Features on page 47.) If this happens, repeat the Start-Up process.

## Shutting the Stove Off (Refer to Figure 29)

1. Press the On/Off switch once; the lights will go off and the fire will go out in a few minutes. The board essentially goes into “Safety Shutdown”.
2. As long as the temperature within the Exhaust System remains above 110°F, the Combustion (Exhaust) Fan will continue to run. When the P.O.F. switch drops out the Combustion Fan will run for another 10 minutes before finally shutting down completely.

**NEVER unplug the Stove to shut it off. Doing so may cause a significant amount of smoke to enter the room.**

## Combustion Air Damper Adjustment

Do not neglect to adjust the Combustion Air Damper during the break in period of your new Stove (See Figure 33 below). Your Stove is equipped with an air inlet damper. The purpose of this damper is to adjust combustion airflow to match the characteristic of each specific air inlet and chimney configuration. See figure 31 on page 41 for initial damper settings. The damper will most likely only need a small adjustment during the break-in period. Break-in requires the burning of 15 bushel of corn or 15 bags of pellets or a continuous burn for two weeks. The setscrew is a useful tool in making adjustments to the Air Intake damper. Adjust the damper by turning the screw a 1/2 turn counter-clockwise to open (**Remember to use the handle to place the damper against the screw**) or by turning the screw a 1/2 turn clockwise (closed). Wait 10 minutes to allow the burn to adjust to the new setting. Making too many changes in a short period of time will not allow for an accurate adjustment. To know if the damper needs to be adjusted you should learn to recognize how Corn, Wheat, Rye, Pellets, Cherry Pits & Distiller’s Grain burn in this Stove system.

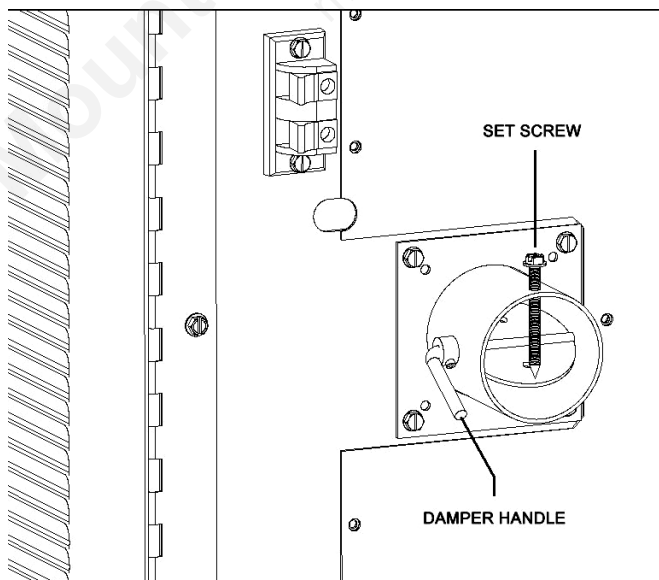

Figure 33

When burning corn, wheat, rye & Distiller's Grain the burn pot should be **"BALANCED"**. This means the fuel that is being augered into the burn pot rapidly turns into glowing coals. If you see a lot of unburned fuel in the pot, an adjustment may be needed. In an unbalanced pot, the corn, wheat or rye will quickly stick together and prevent the proper flow of combustion air. The pot will overload and the fire will go out.

Check for the formation of creosote in the unit and venting system when burning pellets. Constantly running the Stove on a low setting with too much combustion air may cause creosote to form. Burn pot temperatures can be "too cool" when burning pellets on low with too much draft. Once the damper is adjusted for your installation, it should not be necessary to make any further adjustments to the damper. The combustion air is automatically increased every time the feed rate is advanced on the control board.

If you notice a difference in the operation of the Stove, *first check to see if the Stove needs cleaning then check to see if there has been a change in the fuel you are burning.* The moisture content of your corn may be too high or the quality of the pellets you are burning may have changed. Changing the Damper may mask the fact that the stove is getting plugged.

**If you experience problems adjusting the Stove during the Break-In Period, contact your dealer.** Some chimney systems will fall outside the norm, for example, a chimney with excessive draft or one with a long horizontal run.

### **Damper Adjustment Procedure.**

The process is different for the Grains than for Pellets and Cherry Pits. This may take some time, so please be patient during this process. After the damper has been adjusted to the unique installation in your home, the control board will do the rest.

Additional draft adjustments can be made using the Draft trim feature built into the control board. Read point 4a on page 39 and read the "Frequently Asked Questions" in the back of the manual.

### **Terminology used when burning Corn, Wheat, Rye or Distiller's Grain**

1. **Balanced** burn pot. This means the fuel rapidly turns into red-hot coals once it is in the burn pot.
2. **Lag time.** This is the time it takes for the corn to start burning and the burn pot to become balanced. Corn will tend to stick together in a clump in the burn pot if the corn feeds in faster than it's burning.
3. **Overloaded** burn pot. Once the corn has formed a clump in the burn pot the pot will overload and slowly the fire will die out.

## Procedure for adjusting the damper for burning Corn, Wheat, Rye & Distiller's Grain:

- a. Once the Stove is burning, leave the control board on the #1 setting for ½ an hour. This will allow the Stove to warm up before any adjustments to the damper are made. After ½ an hour, look in the burn pot to see if the burn pot is balanced. The Stove should be burning fine and an adjustment is most likely not needed.
- b. Advance the heat setting to #2 and let the Stove burn at this setting for ½ an hour. Check the burn pot to see if it is balanced. Most likely the Stove will be burning fine at this point.
- c. Advance the heat setting to #3 and let the Stove burn at this setting for ½ an hour. Check the burn pot to see if it is balanced. **Remember:** Look at the coals in the pot, not at what the flame looks like. Most likely the damper will not need to be adjusted.
- d. Advance the heat setting to #4 and let the Stove burn at this setting for ½ an hour. Check to see if the pot is balanced. This is where a damper adjustment *might* need to be made. As the heat setting reaches the higher settings the “**Lag time**” can become too long if the air isn't adjusted correctly. If you notice that the coals are being covered up with unburned fuel, adjust the damper to give it more air. **Remember:** Only turn the setscrew one ½ turn **counter-clockwise** to open the damper **and remember to use the handle to place the damper against the screw** (You might need to use a screwdriver to break up the clump of corn in the burn pot to allow for proper airflow). Wait 15 minutes to see if the burn pot becomes balanced. Repeat this step as many times as needed until the burn pot becomes balanced.
- e. Advance the heat setting to #5 and let the Stove burn at this setting for ½ an hour. Check the burn pot to see if it is balanced. A small damper adjustment might need to be made at this time to make sure the “**Lag time**” isn't too long. **Remember:** Only turn the setscrew one 1/2 turn **counter-clockwise** to open the damper **and remember to use the handle to place the damper against the screw**. Wait 15 minutes to see if the burn pot becomes balanced. Repeat this step as many times as needed until the burn pot becomes balanced.

**If the Stove has been connected to an existing chimney system that has good natural draft, the procedure mentioned in the last 2 points above may actually require that the damper gets closed slightly instead of opened to compensate for the additional draft in the chimney system.**

The process of adjusting the damper when burning Grain will take about 3 hours, but it only needs to be done once during the initial burn.

## **Procedure for adjusting the damper when burning Pellets & Cherry Pits:**

When burning pellets or cherry pits the adjustment to the damper should be made when the stove is running in the pilot mode (#1 heat level). A proper burn while burning on Level 1 will prevent creosote formation in the venting system. Running the stove with too much air on the low burns will cause smoke and low Burn Pot temperatures and this can lead to Creosote formation.

- a. If a *heavy* black shiny build-up (difficult to wipe off) is noticed on the glass and inner surfaces, after the Stove runs on the low (pilot) setting for an extended period of time, the damper must be closed some. If this build-up is noticed start closing the damper by adjusting the set screw. Some build up on the glass is normal and should be removed during the maintenance schedule.
- b. Once the adjustment has been made for the pilot setting, slowly advance the Stove to the #5 Heat Level and observe the flame. If black soot (wipes off easily) builds up on the glass and black smoke is visible at the tips of the flames turn the setscrew one ½ turn counterclockwise and bring the damper blade up against the screw. Wait 5 – 10 minutes before attempting another adjustment. An occasional wisp of black smoke is normal every now and then.

**Damper Adjustment, Pilot Settings & Thermostat Control** - The Stove may be controlled with a thermostat to help maintain a more constant temperature. A corn or pellet Stove will be a little slower in reacting to a thermostat than the typical gas, electric or oil fired Stove. By using the Trim Button as mentioned in point 4b on page 39, the feed rate can be adjusted to allow the heat output during the pilot stage to be matched to the size of the home. A larger home will require more heat than a small one. Keep in mind that the Stove is constantly producing some heat that helps heat the home while the Stove is in pilot mode. If the home seems too warm, and the Thermostat is never calling for heat, a lower pilot setting may be a better fit for the home.

**Remember: Choosing a lower Pilot setting may require the damper to be fine-tuned to match the lower feed rate. Monitor how the Stove is operating after a change is made and adjust the damper as needed.**

## Diagnostic Features of the Control Board

The #2 LED, #3 LED, #4 LED and #5 lights on the LED Light bar will flash to give a diagnostic code to help in diagnosing problems that may occur. (See point 3 through 7 in the Frequently Asked Questions section in the back of the manual).

These conditions fall into the following categories:

- a. Heat related issues.
- b. Vacuum related issues.
- c. Issues related to the Rotation of the Drum in the Pot.
- d. The SmartScan Sensor checks the burn level in the Burn Pot.

The Diagnostic Lights flash as follows:

1. The **Vacuum** switch. For the Stove to operate correctly the firebox needs to be sealed. The control board will check to see if the switch senses negative pressure (Vacuum) in the firebox of the Stove. If there is no negative pressure, the Auger will quit feeding and the drum will start rotating until the Stove completes the safety shutdown. The #2 LED will start blinking.
2. The **Proof of Fire** switch. This switch will sense the temperature of the Exhaust rising during start up. If the Exhaust temperature does not reach 110 degrees F, or if, during use, the temperature drops below 110 degrees F, the Auger will quit feeding fuel and the drum will start rotating until the Stove completes the safety shutdown. The #3 LED will start blinking.
3. The **High Limit** switch. This sensor will sense if the unit reaches temperatures that are too high for normal operation. If this happens the Auger will quit feeding and the drum will start rotating until the Stove completes the safety shutdown. The #4 LED light will start blinking. *This is the same LED used for the Revolution Pot Sensor.*
4. The **Revolution Pot sensor**. If the pot fails to rotate or jams during a rotation, both augers are disabled and the drum will start rotating until the Proof of Fire switch opens. The #4 LED will start blinking. *This is the same LED used for the high limit switch.*
5. The **SmartScan Maintenance Sensor**. This new Patent Pending sensing system uses an Infra Red sensor that monitors the burnpot area of the stove. If the fuel builds up on the back edge of the pot the stove will shut down and the #5 LED will start blinking. This is an indication that Maintenance should be performed before the unit is fired up again.
6. If the stove is **shut down** and the **#5 LED is on continuously**, then the Rotating Drum is jammed and not in the correct position. Unplug the stove and remove the jam in the pot.

**“Internal Alarm”** - When the control board becomes unresponsive, the control board is in Internal Alarm. The control board has sensed one of the Safety Sensors. This may cause the stove to go out. In some cases, after waiting approximately 45 seconds the stove will start responding to the control board again. Many times, the cause of this is a change in the vacuum inside the Stove. This may be caused by excessive wind or by opening the Firebox door. The control board will monitor the vacuum switch and resume normal operation if the vacuum returns to normal.

## Safety Features

1. **”High Limit” Switch**, an overheat safety switch will shut off the fuel feed if the Stove reaches temperatures above normal operating temperature. This is a “Normally Closed” switch and is part of the Fan Limit Control. If the High Limit Switch trips several times, the problem in the Stove *must* be diagnosed before the Stove is put back in service, (Defective Room Fan, dirty Room Fan, dirty Air Filter, defective Fan Limit Control or possibly a bad Control Board)
2. **Vacuum Switch** also called the **Negative Pressure Switch**. When the Stove is turned on the exhaust fan will create a negative pressure in the firebox. The control board continually checks to see if Negative Pressure (vacuum) is present during operation of the Stove. If the exhaust venting system becomes clogged or obstructed, the firebox door is left open or the exhaust fan quits working the control board will go into “Safety Shutdown”. For maintenance purposes there is a 60 second window to allow for cleaning the glass, etc. before the Stove shuts down. This allows sufficient time for the Daily Maintenance.
3. **Proof of Fire Switch** also called the **P.O.F.** This senses the temperature rise in the exhaust system. The switch is “Normally Open” and closes the circuit at 110 degrees. The Stove will shut down if temperatures above 110 degrees F are not sensed during start up or if the temperature drops below 110 degrees during normal operation.
4. **Hopper Lid Switch**. The hopper lid switch will shut off the auger motor when the hopper lid is open. Be sure the lid closes completely when refilling the hopper or the unit will shut down.
5. **Revolution Pot Sensor**. This is a micro switch located on the Revolution Pot drive shaft. It monitors the rotation of the drum during the Self-Cleaning action. If the drum does not rotate every 2 hours, the stove will go into shut down mode.
6. **SmartScan Sensor**. This is an Infra Red Sensor that shoots an Infra Red beam across the firebox and bounces it back using a reflector. Any obstacle that interferes with the beam for longer than 60 seconds will shut the unit down.

**WARNING: These safety features are designed to protect life and property. Bypassing these features voids all warranties and the safety listing of the Stove.**

**The Lincoln SCR has been Safety Tested by an accredited, independent laboratory.**

## LINCOLN SCR MAINTENANCE

**NOTE: WHEN YOU FIRST OPERATE YOUR STOVE, CHECK TO DETERMINE THE NEEDED CLEANING FREQUENCY. THE STOVE REQUIRES A MINIMUM AMOUNT OF DAILY MAINTENANCE. REQUIRED MAINTENANCE DEPENDS LARGELY UPON THE QUALITY OF FUEL BURNED AND THE RATE OF BURN. THE AMOUNT OF DAILY MAINTENANCE WILL INCREASE IF FUEL QUALITY DECREASES AND/OR THE BURN RATE INCREASES.**

**NOTE: FAILURE TO KEEP YOUR STOVE CLEAN, AS DESCRIBED IN THIS MANUAL, COULD RESULT IN POOR OPERATION, INEFFICIENT FUEL USAGE AND A POSSIBLE SAFETY HAZARD! IT IS THE RESPONSIBILITY OF THE OWNER/USER TO DETERMINE THE NEEDED MAINTENANCE FREQUENCY.**

**CAUTION: THE DOOR AND FRONT PART OF THE STOVE WILL BE HOT. DO NOT TOUCH ANY PART OF THE STOVE THAT IS HOT!**

### Daily Maintenance

1. **The Ash Pan.** Make sure the Ashpan is not too full. If the Ashpan is too full, the ash may not be dumped from the Revolution Pot when it runs a cleaning cycle.
2. **The Tube Scraper.** Pull the Tube Scraper back and forth a couple of times to keep the tubes clean. If the Tube Scraper feels sticky and difficult to move, check for the presence of creosote on the tubes. If creosote is present a damper adjustment may be needed or the Stove has become plugged and needs a thorough cleaning. Call Dealer for assistance. *(See figure 5 on Page 11 for the location of the Tube Scraper Rod).*
3. **Clean the Viewing Glass.** Use a dry paper towel to clean the glass. Quickly open the door and wipe the glass. The rate of burn will determine how often the window needs cleaning. Prolonged burning at a low burn rate will result in the need for more frequent window cleaning. Cooling the Stove and wiping the window daily with a cloth or paper towel will normally keep the window from accumulating difficult to clean residue. Use of a glass cleaner **ONLY** permitted when the Stove is cold.

**CAUTION:** Do not slam the door. Do not operate the Stove with a broken or cracked glass. Replace only with heat resistant ceramic glass supplied by the manufacturer.

## Periodic Maintenance

**CAUTION:** Periodic maintenance should only be done while the Stove is shut off and cold.

1. **Ashpan.** Empty the ash pan when it appears full (approximately twice a week). *The frequency of cleaning the ash pan will depend on the quality and amount of Corn/Pellets being used.* Carefully check to make sure the ash pan door is tightly closed after each time it has been opened.
2. **Revolution Burnpot.** Clean Burn Grate holes whenever needed. Clean the burnpot while it is in the Stove. Remove the pot Side Shields (See Figure 26 on Page 34) and use a stiff bristle brush to remove any ash build that may be plugging the holes. To clean the holes in the front of the pot remove the panel below the door and then remove the Igniter Assembly. Clean the holes in the front of the pot through the opening behind the Igniter. *If the unit is slow in lighting, make sure the hole in front of the igniter is not plugged.*

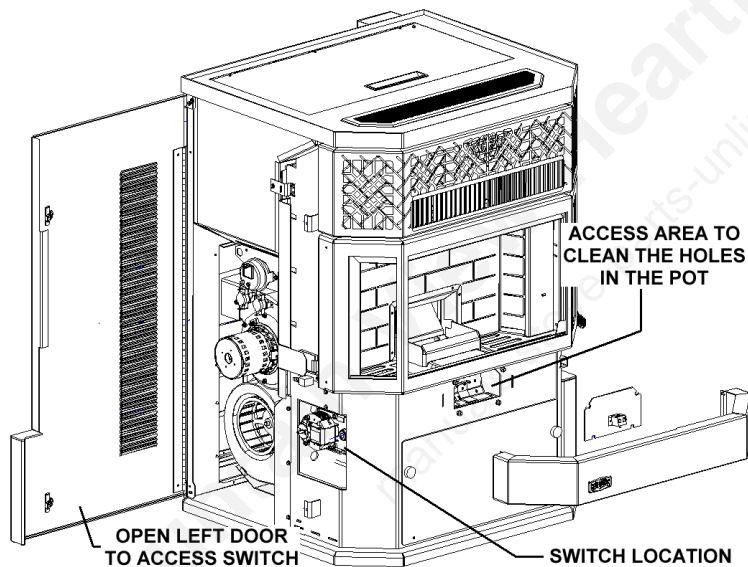

By tripping the switch lever, shown in detail in figure 34 below, the burn pot will cycle to another section. Repeat this until all 4 sections of the drum have been cleaned. Check each section and all holes with a small mirror to verify they are clean.

If the holes in the pot remain plugged, remove the Burnpot, (as shown in Figure 26 on Page 34 & figure 27 on page 35) and use a small metal object (Nail, Drill Bit, etc) to clean out plugged holes.

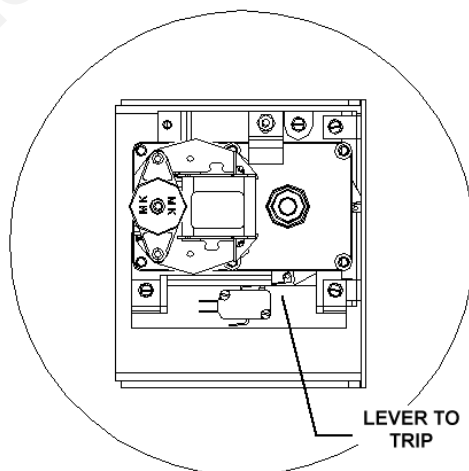

Figure 34

3. **Clean-Out Ports.** The Stove has 2 Exhaust Cleanout Ports located behind the Ashpan. Remove covers and clean once a month or every ton of fuel.

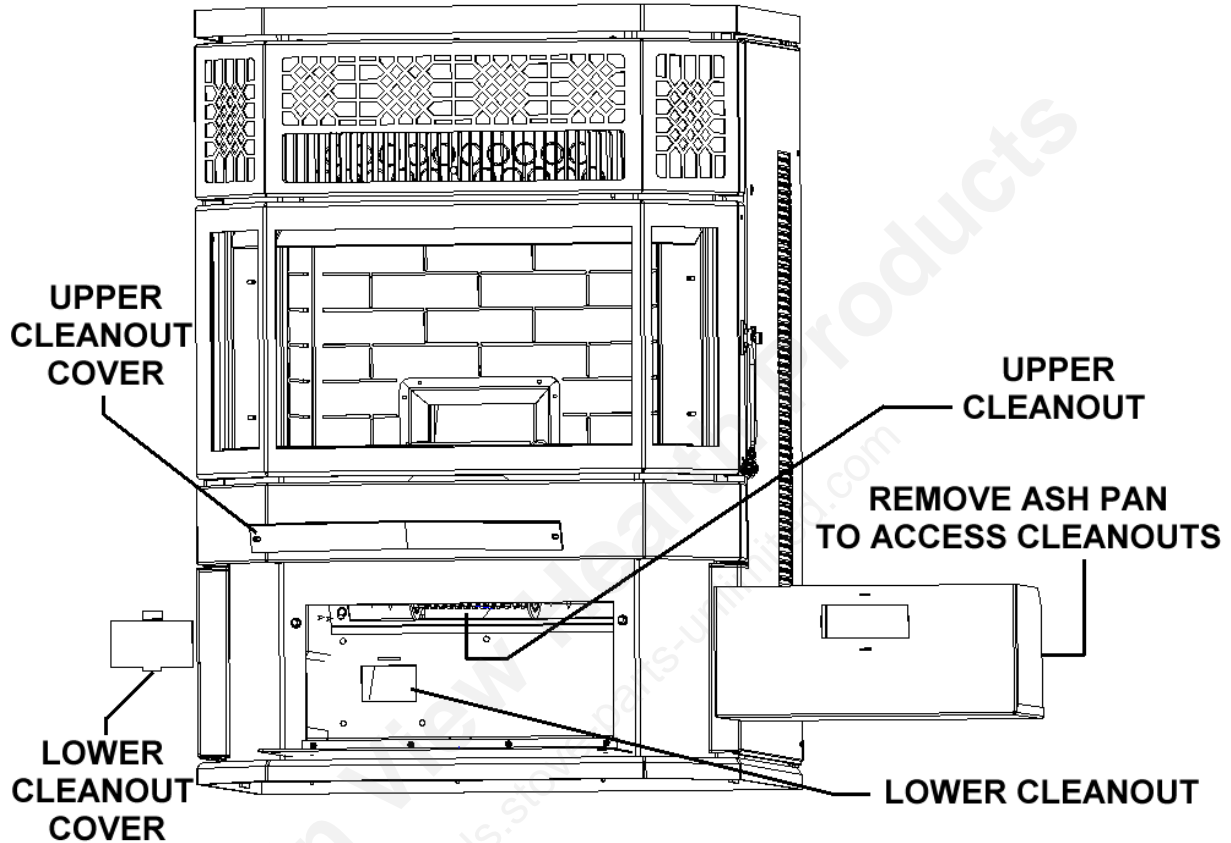
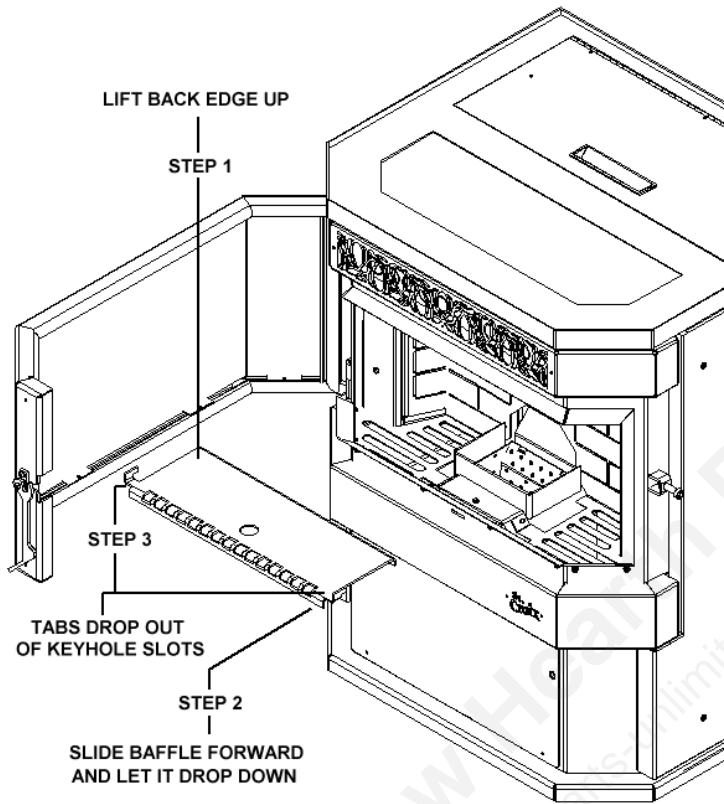

Figure 35

Frequency of cleaning depends on the amount of fuel being burnt and the quality of the fuel. **Failure to clean the ash traps will cause the Stove to become plugged with fly ash.**

4. **Heat Exchange Baffle.** Remove the baffle and clean the ashes that accumulate on a regular basis. Once a month or sooner, depending on the quality of fuel being used (*See Figure 36 on the next page*) Clean the baffle on a regular basis. Frequency of cleaning depends on amount of fuel being burnt and the quality of the fuel. Fuel with low ash content is recommended. **Failure to clean the baffle can cause the Stove to become plugged with fly ash.**

## Baffle Removal



To remove the baffle, lift the back of the baffle up to clear the inner back of the Stove and slide towards the front of the Stove. The baffle will slide out of the keyhole slots and drop down.

*When putting the baffle back in the Stove, make sure the Tabs are in the Keyhole slots and the back of the baffle is lifted up over the inner back to keep the Baffle locked in place.*

Figure 36

- 5. Exhaust System.** Periodic cleaning of the exhaust system is required. Under certain conditions chimneys may plug up rapidly. Dirty grain that has high moisture content or pellets with high ash content or installations with elbows and horizontal runs require more frequent chimney cleanings. See Page 30 “Preventing Chimney Fires”. The products of combustion will also contain small particles of fly ash. The fly ash will collect in the exhaust vent and restrict the flow of the flue gases. Judge the frequency of cleaning by checking the amount of ash that accumulates in the elbows or tee’s of the exhaust system. Ask the dealer for suggested frequency of cleaning, equipment needed and procedures for cleaning. Check the exhaust system at least once every two months during the heating season.
- 6. Gaskets.** Periodically inspect the condition of the rope gasket around the door, window and ash door. Replace as needed.
- 7. Air Filter.** Check the Air Filter at least once a month and clean or replace when needed. The filter material may be purchased at a local hardware store and cut to size to fit into the filter bracket.

Many dealers offer a Service Contract that will cover Yearly Maintenance. Contact your St. Croix Dealer for assistance in maintaining your Stove in top condition.

## Yearly Maintenance

Yearly maintenance is designed to assure safe operation, prolong the life of the Stove and help preserve its aesthetic appeal.

1. **Spring Shutdown.** After the last burn in the spring, cool the Stove and remove all fuel from the hopper and the auger system. Thoroughly clean the burn pot, burn pot box, ash pan and ash traps behind the ash pan. (To locate the ash traps see figure 35 on page 51)
2. The exhaust system should be thoroughly cleaned at least annually. Call your dealer for this service.
3. The motor/fan area behind the firebox and under the hopper should be vacuumed annually.

**NOTE: UNPLUG THE STOVE.** Remove the access panels of the Stove. Carefully clean or vacuum any dust, cobwebs and household dust. Carefully vacuum around the fan motors. If electrical wires become disconnected call your dealer for service if needed.

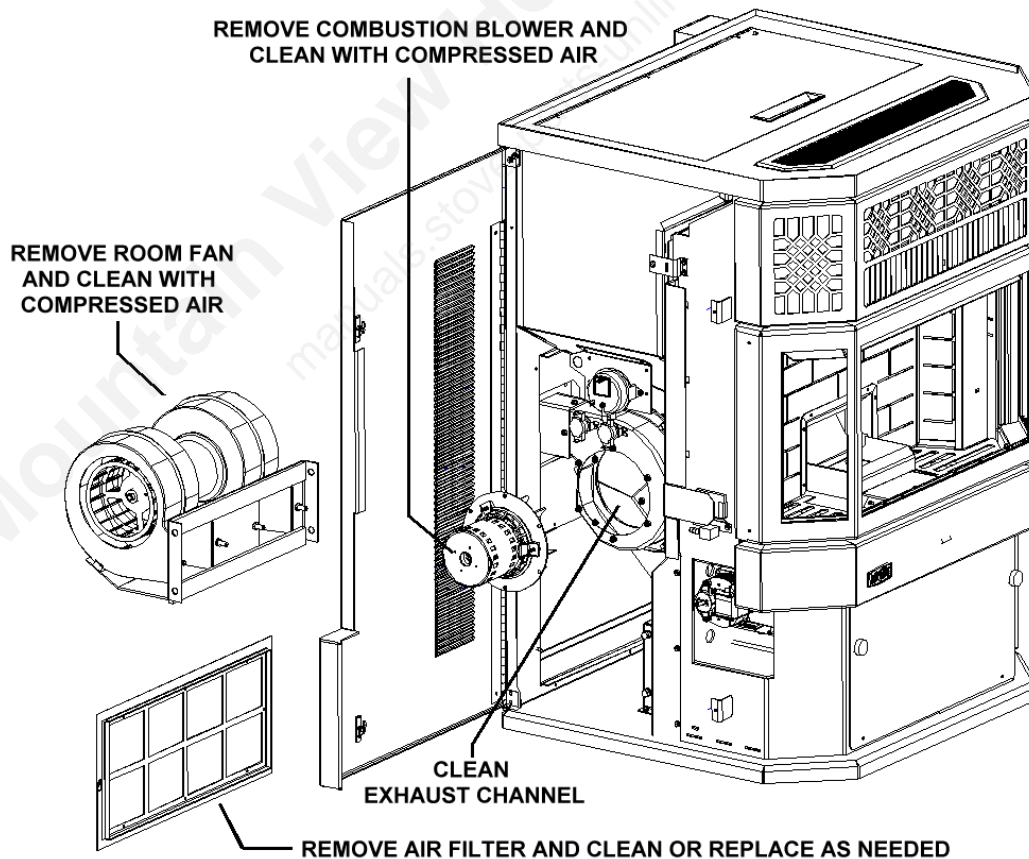

Figure 37

4. The Exhaust Fan (Combustion Fan) should be removed (may require a new gasket) and cleaned with compressed air annually. Call dealer for this service. Annual oiling of the motors is not needed.
5. The Convection Blower should be removed and cleaned with compressed air annually. There are 2 oil ports on the motor.

**Fall Startup.** Prior to lighting the first fire check the outside area around the exhaust and air intake systems for obstructions. Try all controls to see that they are working prior to lighting a fire.

### **SAFE OPERATION.**

1. **Disposal of Ashes.** Ashes should be placed in a metal container with a tight fitting lid. The closed container of ashes should be placed on a non-combustible floor or on the ground, well away from all combustible materials, pending final disposal. If the ashes are disposed of burial in soil or otherwise locally dispersed, they should be retained in the container until all cinders have thoroughly cooled.
2. **Never use Gasoline,** gasoline type lantern fluid. Kerosene, charcoal lighter fluid or similar liquids to start or “freshen up” a fire in this heater. Keep all such liquids well away from the heater while it is in use.
3. **Creosote, Soot and Fly Ash: Formation and Need for Removal.** The products of combustion will contain small particles of Fly Ash. The fly ash will collect in the venting system and restrict the flow of flue gases. Incomplete combustion, such as occurs during start-up and shut-down, or incorrect operation of the room heater will lead to some soot or creosote formation which will collect in the venting system. The exhaust system should be inspected regularly during the heating season to determine if creosote buildup has occurred. Check more frequently at first to determine a schedule for cleaning the venting system based on individual use of this Corn/Pellet-burning heater. If creosote has accumulated, it should be removed to reduce the risk of a chimney fire.
4. **Do not Overfire this unit.** Follow all instructions regarding the proper use of this heater.

## Wiring Schematic

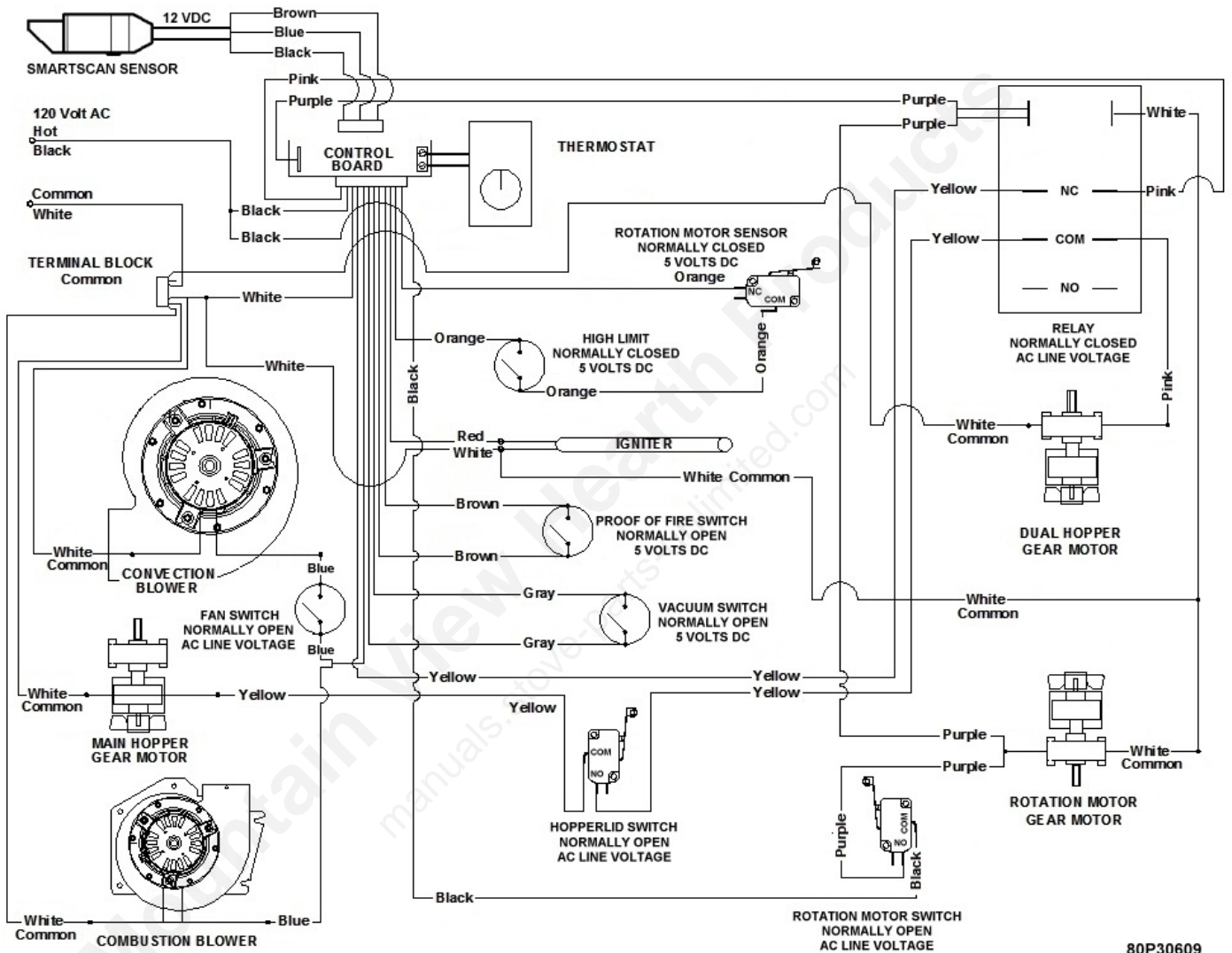

Figure 38

The Electrical Rating of this Stove is: 120 Volt, 60 Hz, 3 AMP. The minimum recommended circuit is 15 Amp. A dedicated circuit for the Stove is recommended.

**CAUTION:** The electrical components of the Stove are not owner serviceable. Call your dealer for proper diagnosis of electrical problems and service to those components.

# Parts Layout

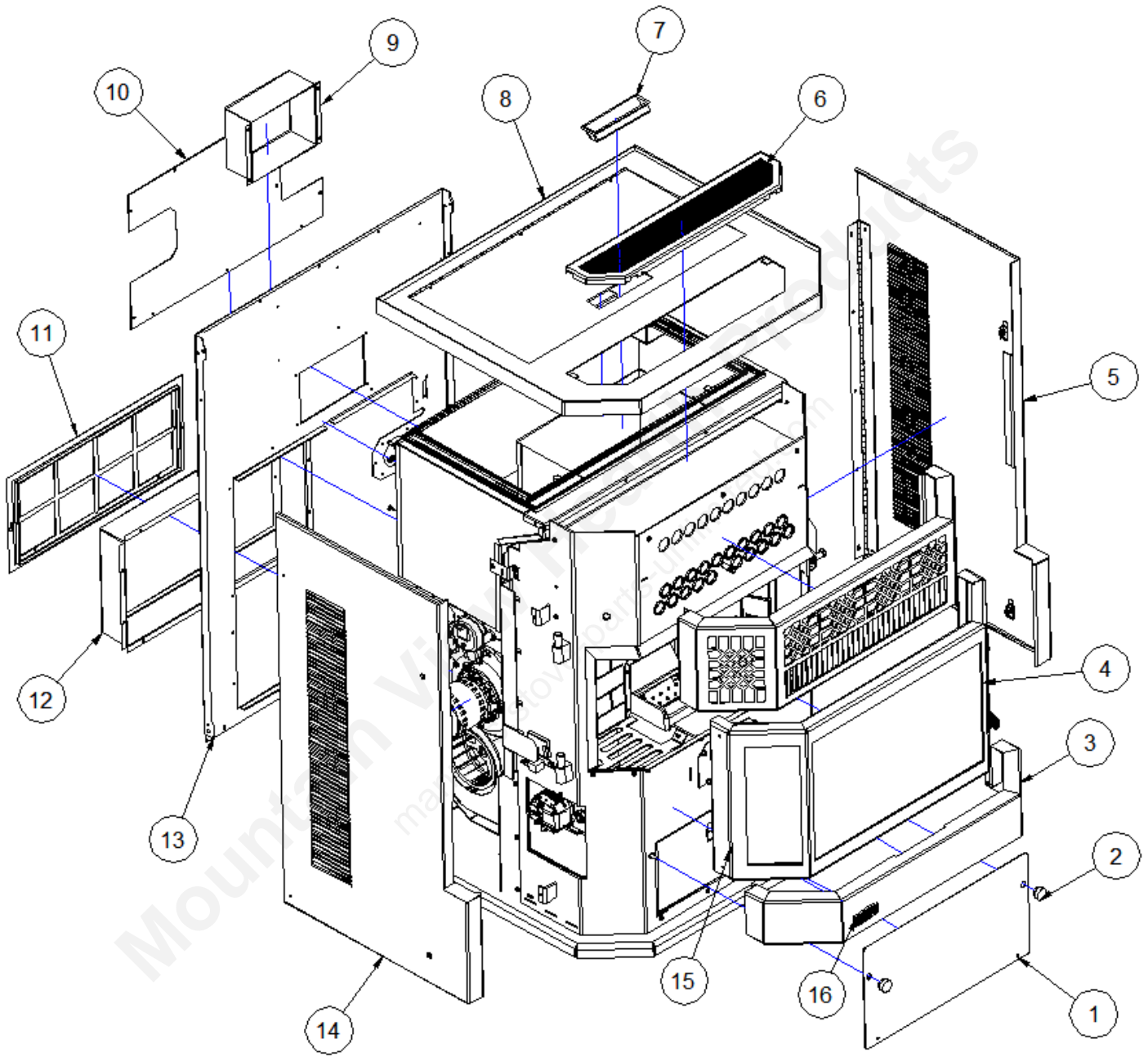

Figure 39

# Parts Layout

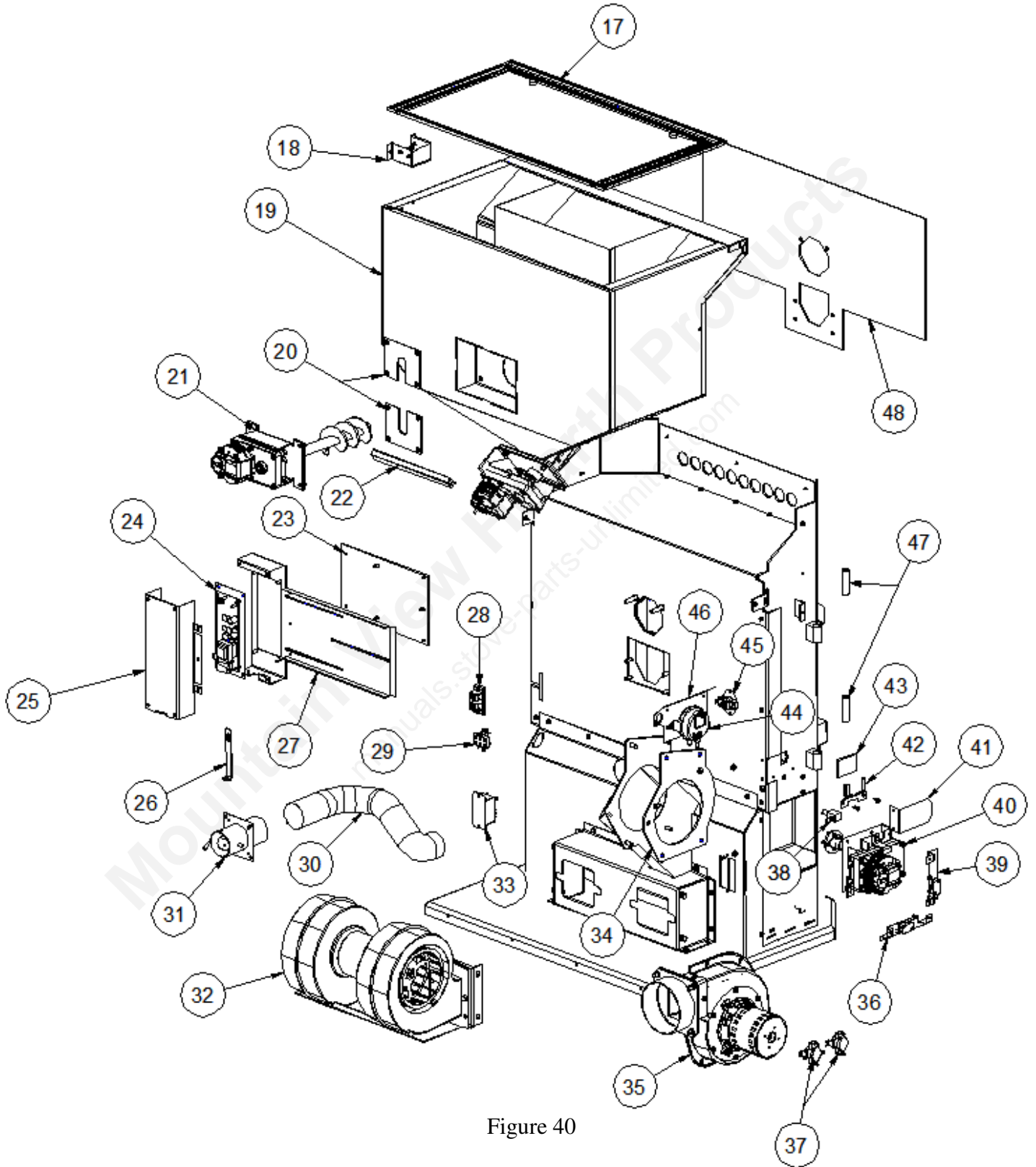

Figure 40

## Parts Layout

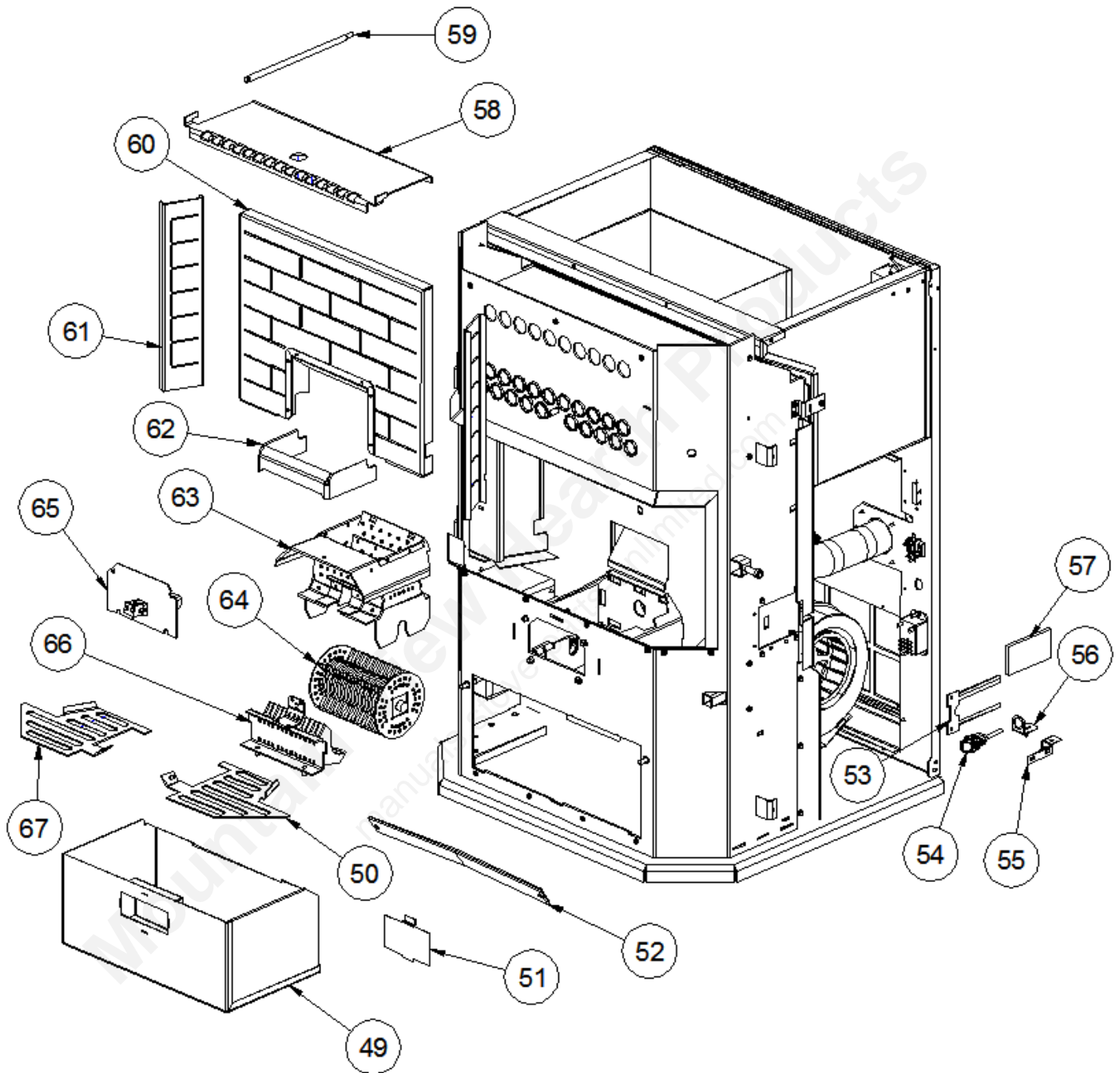

Figure 41

# Parts Layout

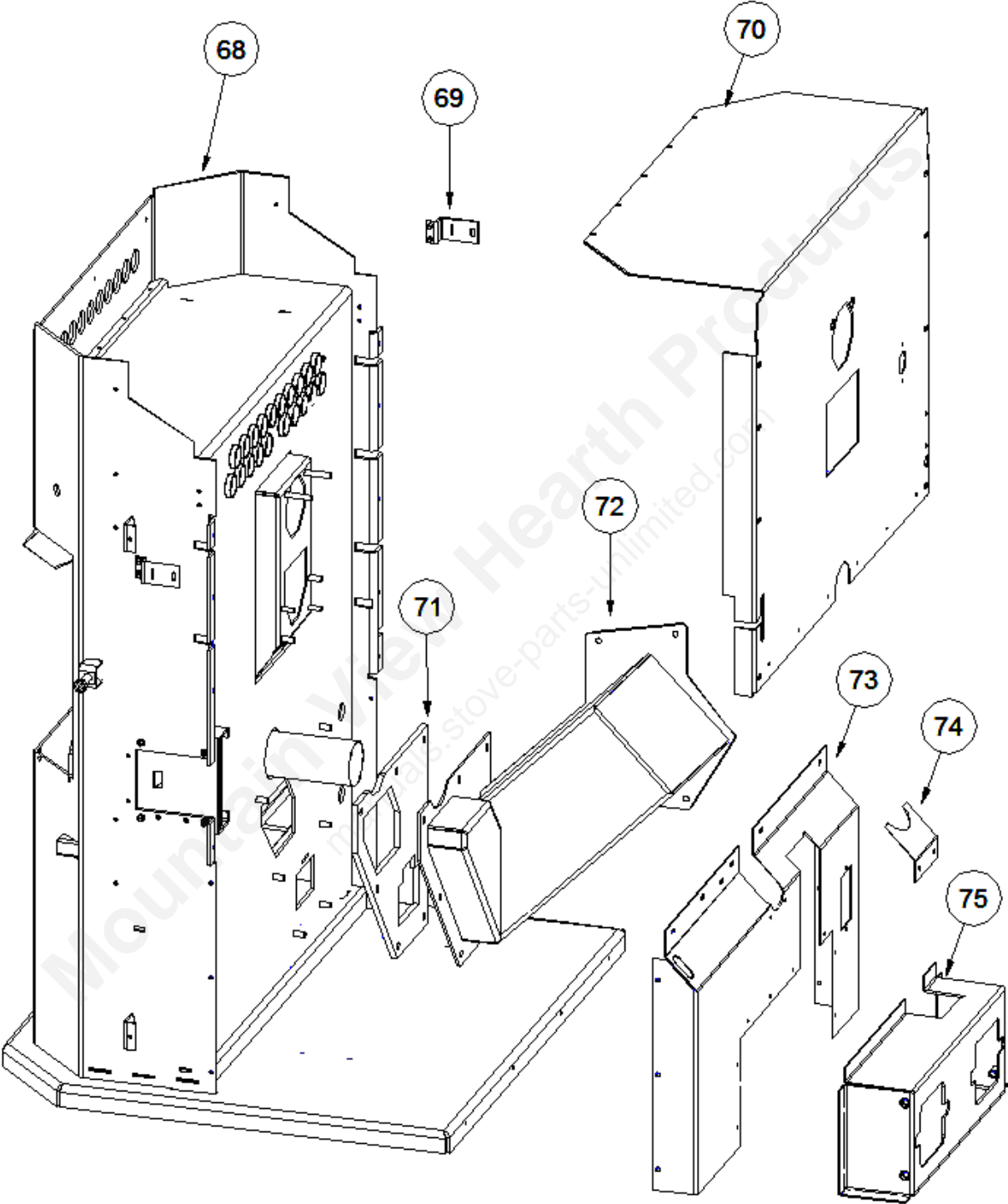
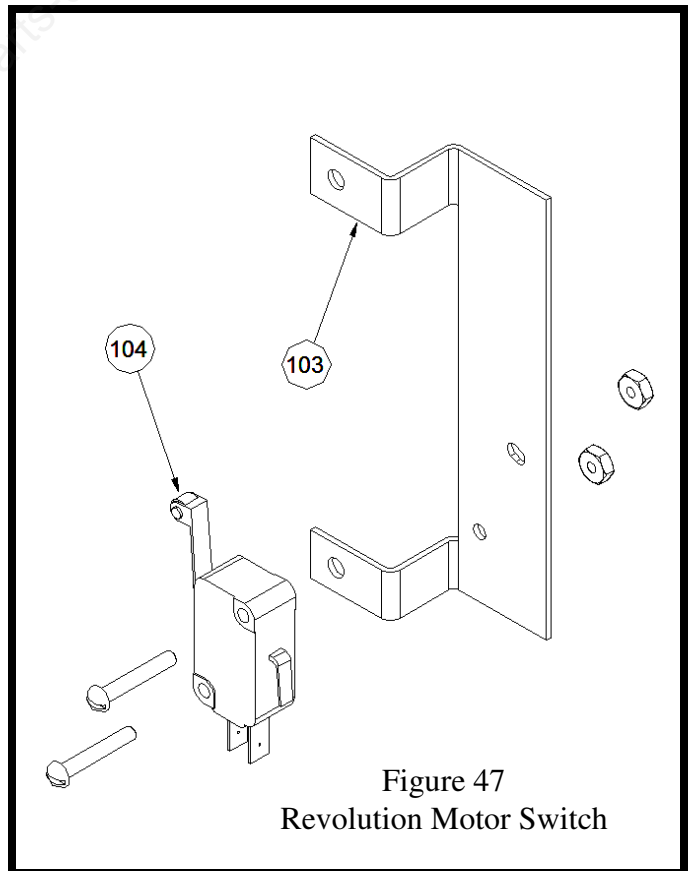
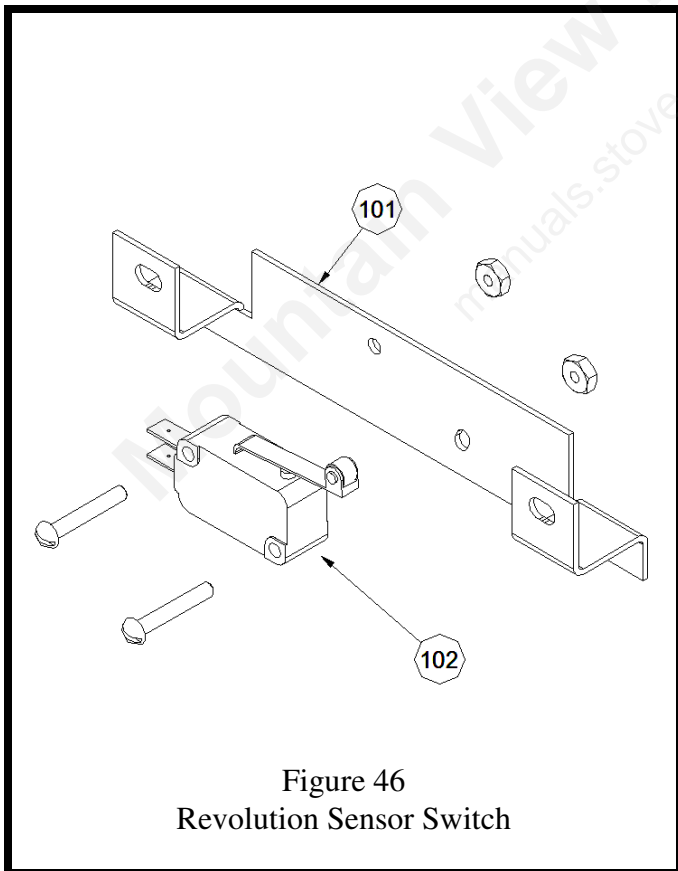
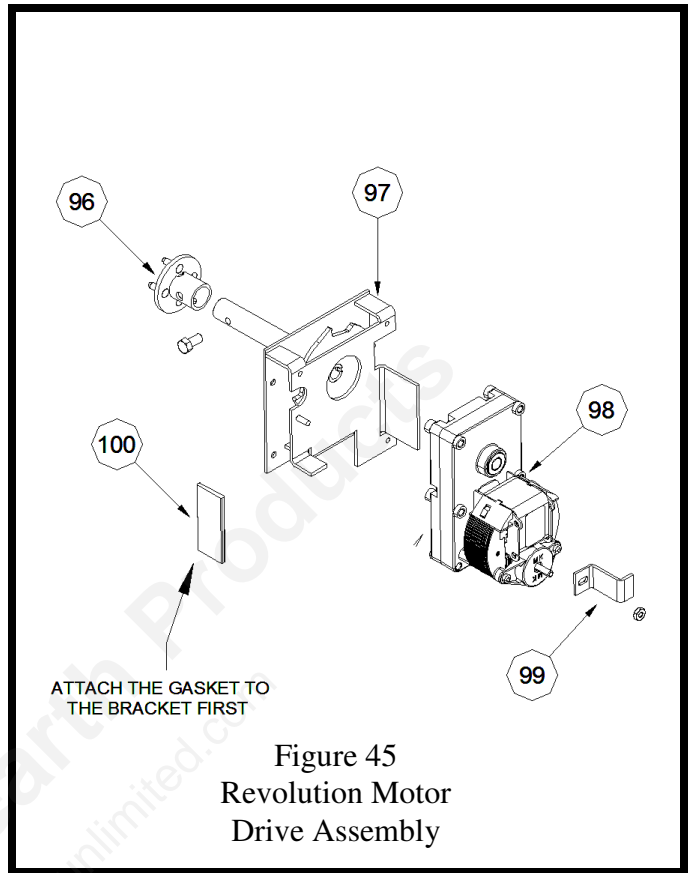
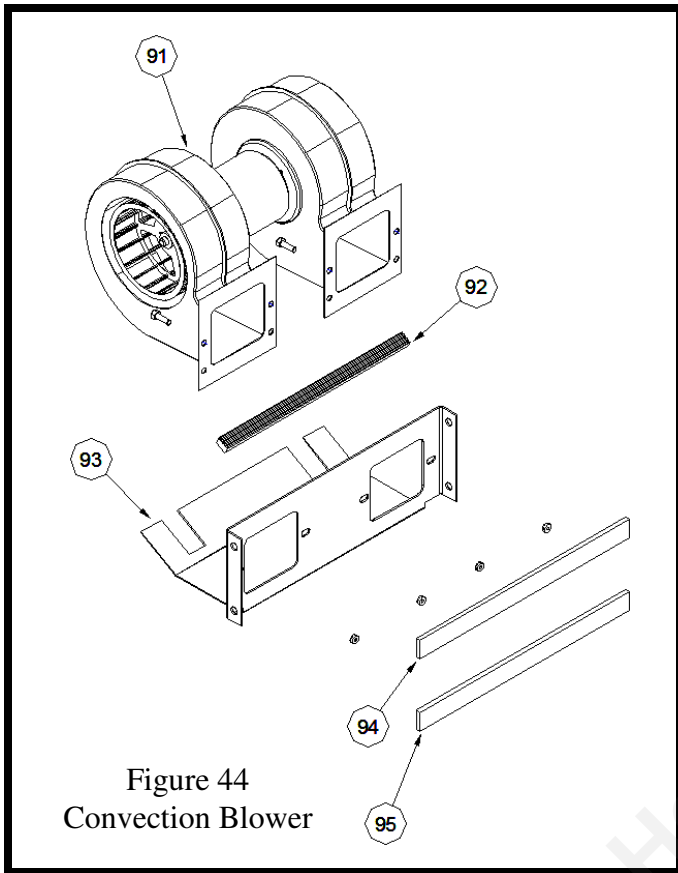
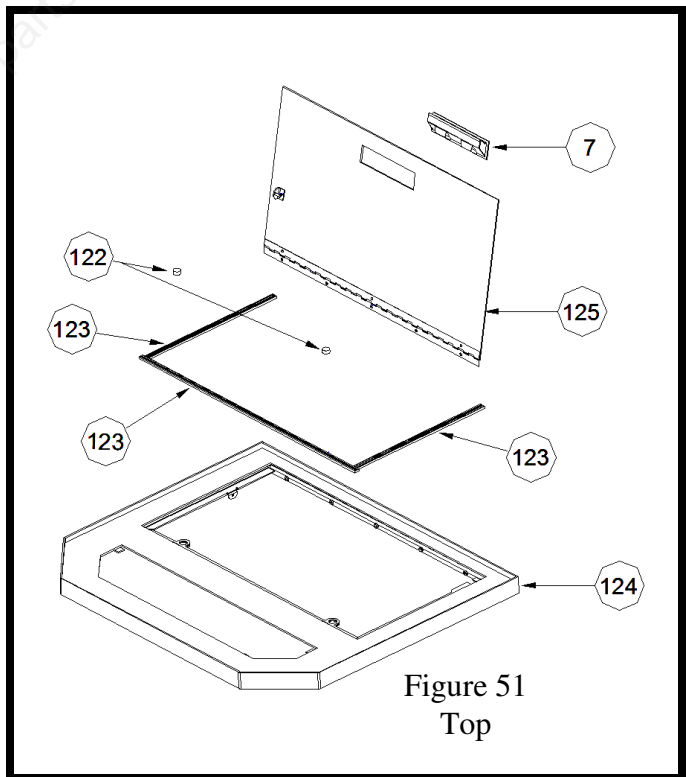
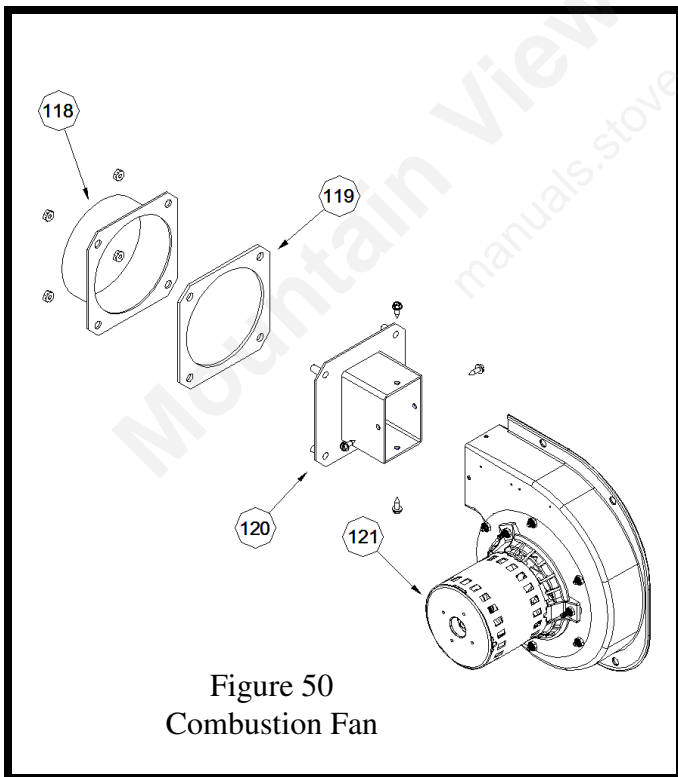
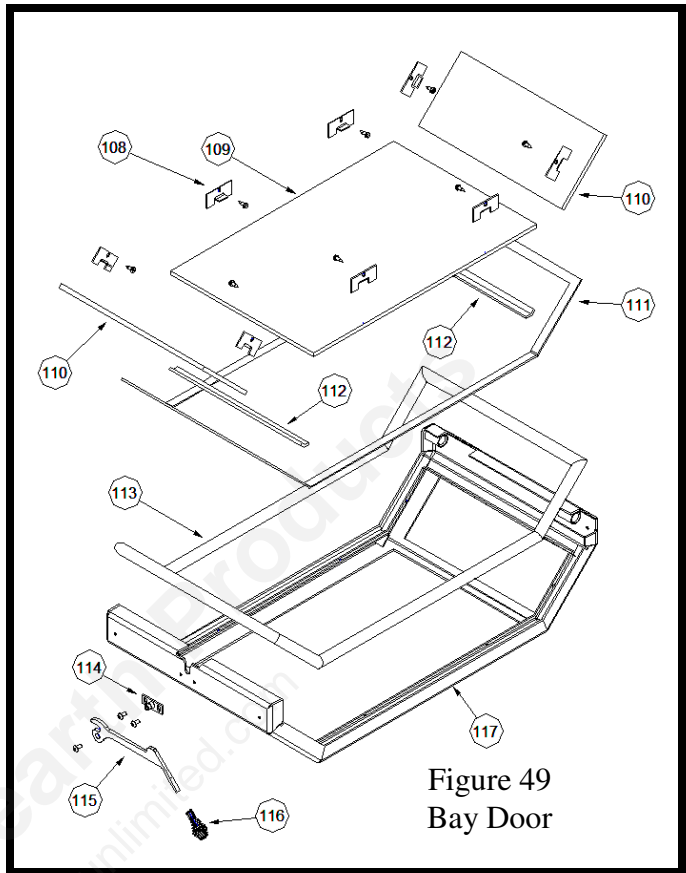
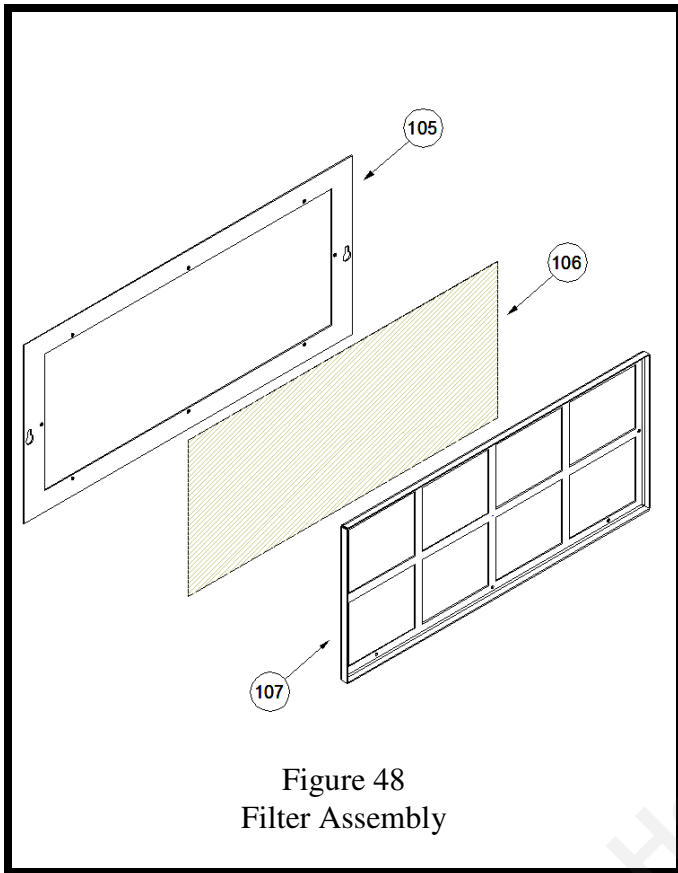

Figure 42







## Part Numbers / Description

See pages 55 through 61

#	PART NUMBER	DESCRIPTION
1	80P53930	ASH PAN DOOR
2	6479K53	ASH PAN KNOBS
3	80P30590	LOWER PANEL
4	80P53725	BAY DOOR - COMPLETE
5	80P54134	RIGHT DOOR COMPLETE
6	80P54156	TRIVET-SCREEN ASSEMBLY
7	80P20183	HANDLE PULL P2-54
8	80P54137	TOP - COMPLETE
9	80P30248	ROTATION GEAR MOTOR COVER
10	80P30483	BACK PANEL COVER
11	80P54000	FILTER ASSEMBLY - COMPLETE
12	80P30501	FILTER BOX
13	80P30820	BACK PANEL
14	80P54132	LEFT DOOR COMPLETE
15	80P54204	HOT AIRBOX ASSEMBLY
16	80P30790	ST CROIX LOGO
17	X113-HT	TRIM LOC SEAL (HOPPER USES 70 “)
18	80P30268	HOPPER LID SWITCH
19	80P54140	DUAL HOPPER ASSEMBLY
20	80P 30604	AUGER BUSHING BRACKET (2 PER STOVE)
21	80P53991	HOPPER B AUGER MOTOR ASSEMBLY
22	80P20403	PLASTIC WIRE DUCT
23	80P53681	SLIDE-TOP STANDOFF PLATE ASSEMBLY
24	80P30608	CONTROL BOARD
25	80P52658	CONTROL BOARD HARNESS RESTRAINT
26	80P54121	ROD PULL TOOL
27	80P53785	CONTROL BOARD BOX WITH CLINCH STUDS
28	80P30045	SPEAKER TERMINAL
29	80P52630	TERMINAL BLOCK
30	80P30736	2” FLEXIBLE ALUMINUM DAMPER TUBE
31	80P53871	INTAKE DAMPER WELDMENT
32	80P53977	CONVECTION BLOWER ASSEMBLY
33	80P30431	RELAY
34	80P20168	COMBUSTION FAN GASKET

35	80P53933	COMBUSTION FAN ASSEMBLY-COMPLETE
36	80P54063	ROTATION SENSOR BRACKET ASSEMBLY
37	80P20038	PROOF OF FIRE DISC (2 PER STOVE)
38	80P52634	BARB FITTING
39	80P54062	ROTATION SWITCH BRACKET ASSEMBLY
40	80P53979	REVOLUTION MOTOR DRIVE ASSEMBLY
41	80P54188	SENSOR REFLECTOR PLATE ASSEMBLY
42	80P30808	GLASS RETAINER - BENT
43	80P30810	SENSOR GLASS
44	80P30658	VACUUM SWITCH
45	80P52629	MANUAL RESET HIGH LIMIT DISC
46	80P52710	VACUUM SWITCH BRACKET
47	80P65021	1/2" DOWEL PIN - MAIN DOOR
48	80P30749	DUAL HOPPER GASKET
49	80P53931	ASH PAN
50	80P30493	DECORATIVE GRILL - RIGHT HAND
51	80P30162	CLEAN OUT COVER PLATE
52	80P54056	CLEAN OUT COVER ASSEMBLY
53	80P30809	GLASS RETAINER
54	80P30948	INFRA RED SENSOR
55	80P30807	RIGHT ANGLE SENSOR BRACKET
56	80P54205	ADJUSTABLE SENSOR BRACKET ASSEMBLY
57	80P30962	SENSOR GLASS
58	80P30506	HEAT EXCHANGE BAFFLE
59	80P52567	TUBE SCRAPER ROD
60	80P54127	REAR BRICK PANEL ASSEMBLY
61a	80P30801	STEEL BRICK LEFT BRICK PANEL
61b	80P30802	STEEL BRICK RIGHT SIDE PANEL
62	80P30829	POT SIDE SHIELDS
63	80P54141	REVOLUTION POT WELDMENT
64	80P54043	POT DRUM
65	80P54130	IGNITER ASSEMBLY-COMPLETE
66	80P54146	CLINKER CUTTER WELDMENT
67	80P30492	DECORATIVE GRILL - LEFT HAND
68	80P54152	FRONT/FIREBOX/BASE WELDMENT
69	80P30857	HOPPER POSITION TAB

70	80P30838	AIR JACKET
71	80P30959	BOLT ON EXHAUST DUCT GASKET
72	80P54143	BOLT ON EXHAUST DUCT SYSTEM
73	80P30837	AIR JACKET-BOTTOM
74	80P30738	AIR JACKET FILLER
75	80P30836	CONVECTION AIR MANIFOLD
76	80P54139	DUAL HOPPER WELDMENT
77	80P53943	HOPPER "B" AUGER WELDMENT
78	80P50858	AUGER BUSHING WASHER
79	80P20248	5/8" COLLAR WITH SETSCREW
80	80P30748	AUGER MOTOR GASKET
81	80P20022	1" GLASS GASKET (3.5")
82	80P20278	AUGER MOTOR
83	80P20278	AUGER MOTOR
84	80P54074	MOTOR MOUNT BRACKET AND END CAP
85	80P20248	5/8" COLLAR WITH SETSCREW
86	80P50858	AUGER BUSHING WASHER
87	80P53990	HOPPER B MOTOR MOUNT ASSEMBLY
88	80P53666	AUGER WELDMENT
89	80P20245	AUGER GASKET
90	80P30191	MOTOR RETAINER BRACKET
91	80P30681	CONVECTION FAN
92	X-103HT	TRIM LOC SEAL (11.25")
93	80P30500	CONVECTION BLOWER MOUNT PLATE
94	8709K46	1" X 1/4" FOAM GASKET (13")
95	8709K46	1" X 1/4" FOAM GASKET (13")
96	80P54042	POT DRIVE COUPLING
97	80P53978	MOTOR MOUNT BRACKET ASSEMBLY
98	80P20278	AUGER MOTOR
99	80P30708	MOTOR RETAINER BRACKET
100	80P20022	1" GLASS GASKET (2.25")
101	80P30709	ROTATION SWITCH BRACKET
102	80P30268	ROTATION MOTOR SWITCH
103	80P30707	ROTATION SWITCH BRACKET
104	80P30268	ROTATION MOTOR SWITCH
105	80P30502	FILTER RETAINER BRACKET

106	80P30607	FILTER
107	80P30620	FILTER FRAME
108	80P52796	BAY DOOR GLASS CLIP
109	80P20034	BAY DOOR FRONT GLASS
110	80P20035	BAY DOOR SIDE GLASS (2 PER STOVE)
111	80P20027	1/2" GLASS GASKET - BAY DOOR (80")
112	80P20024	3/4" GLASS GASKET - BAY DOOR (20")
113	80P20026	5/8" ROPE GASKET - BAY DOOR (80")
114	80P53723	MOUNT PLATE ASSEMBLY
115	80P60278	DOOR HANDLE
116	80P20131	SMALL BRASS COIL
117	80P53724	BAY DOOR FRAME - WELDED
118	80P53804	QUICK CONNECT PIPE WELDMENT
119	80P30149	QUICK DISCONNECT GASKET
120	80P54053	EXHAUST ADAPTER PLATE WELDMENT
121	80P30521	COMBUSTION FAN
122	80P30561	MAGNET
123	X-113HT	TRIM LOC SEAL (44")
124	80P54137	TOP WELDMENT
125	80P54136	HOPPERLID WELDMENT

### PARTS NOT SHOWN

	80P30963	WIRING HARNESS
	80P20004	POWER CORD

## TROUBLESHOOTING & FREQUENTLY ASKED QUESTIONS

The Stove is very trouble free in operation when properly maintained and quality fuel is used. When the Stove fails to operate properly, troubleshooting by the operator of the Stove is limited. Please read the following guide for answers to frequently asked questions

### Questions:

1. When first starting the Stove the auger tube is empty, this will delay feeding fuel to the burn pot. This will in some cases prevent the Stove from starting.

**Solution:** First allow the revolving drum to rotate after turning the Stove on. Prime the auger tube with fuel if the auger tube is empty, by holding the “Auger Feed” until the tube is full.

2. **My Stove keeps overloading the burnpot.** First check the quality and/or moisture content of your fuel. It should be 15% or less. Also make sure you are using clean fuel. Otherwise this is mainly caused by improper combustion. (See **Damper** Adjustment section of the Operations Manual) Besides the damper adjustment there are several areas that can have an effect on the combustion process.

**Solution:** Check all Gaskets, Doors and Door Latching Systems for air leaks. Any leaks in these areas will negatively affect the burn process and cause the pot to overload. If all parts check out OK, then the Feed Rate **must** be reduced to prevent the pot from overloading.

3. **My Stove isn't burning and the number 2 LED light is blinking (*the pot may be continually rotating*)** This diagnostic light indicates the vacuum switch no longer senses negative pressure in the firebox area of the Stove. What caused the Stove to go out?

- a. The door of the unit was left open longer than 60 seconds. (**See solution**)
- b. The ash pan door was left open for longer than 60 seconds. (**See solution**)
- c. The combustion fan is not running. (Defective fan or control board)
- d. The vacuum switch is defective.
- e. The vacuum hose is disconnected
- f. The vent system is plugged with fly-ash.

**Solution:** **If the fire is out**, re-light the Stove. **If the fire is still burning** make sure all doors are securely latched and hold down the On/Off button (approximately 5 seconds) until Stove starts up again. This will re-start the Stove in the start-up program.

4. **My Stove isn't burning and the number 3 LED light is blinking (*the pot may be continually rotating*)**. This diagnostic light indicates that the Proof of Fire Switch no longer senses a fire in the Stove. First check to see if there are pellets in the hopper. If there are pellets in the hopper, why did the Stove go out?

- a. Unburned fuel in the burnpot means the fire went out before the auger quit feeding.

**Solution: Too much Combustion Air on the pilot setting.** Adjust the air damper. (See section covering an *Unbalanced Burnpot*). Corn/Pellets would still feed until the P.O.F. switch eventually shuts the Stove down. Adjust the damper. (See *Damper Adjustment* in the Operations Manual)

A power Failure could also cause this. If the Stove is still hot when the power comes back on, the feed system will resume at level 1. If the fire had gone out in the pot, the feed would continue to run until the Proof of Fire switch dropped out and shut the Stove down.

- b. If all the fuel is burned up, means the auger quit feeding fuel while there was still a fire in the burnpot. Check to see if there is fuel in the hopper. If the hopper is empty, fill the hopper and re-light the Stove.

If there is fuel in the hopper check to see if there is an obstruction in the auger system or if the auger set screw is loose.

**Solution:** Remove obstruction and re-light the Stove or tighten the setscrew on the auger shaft.

5. **My Stove isn't burning and the #4 LED light is blinking (*the pot may be continually rotating*).** This means the High Limit has shut the Stove down or the Rotation Pot Sensor failed to sense a pot rotation during the cleaning cycle. First check if the furnace pot is jammed. Check to see if the switches are lined up correctly. If the rotation pot is functioning correctly, then check the Convection Blower to see if it is defective or needs cleaning. The high limit switch may be also defective. It is best to call your dealer for support when trying to troubleshoot the High Limit Switch. Do not use your Stove if the High Limit switch frequently trips.

The Convection fan initially is turned on by a fan switch attached to the exhaust system. The temperature must reach 110 degree F. A defective Fan Switch or if the connections are bad would prevent the Convection Fan from running. This would cause the High Limit Switch to trip.

6. **My Stove isn't burning and the #5 LED light is blinking (*the pot may be continually rotating*).**

This means the SmartScan Sensor has detected that the unit is not burning correctly and has shut the unit down. Check the following areas of the stove: *Plugged Venting System, Plugged Stove, Dirty Burn Pot, Worn Door Gaskets, Worn Glass Gaskets or Weak Combustion Fan.*

Also check to make sure that the quality of fuel is not causing the unit to burn incorrectly. Poor Fuel Quality should not be ruled out, make sure they are 100% wood pellets, many blends of pellets are being sold that have are not approved in pellet stoves.

Periodically check the Glass lenses used in the SmartScan System (See Figures 23, Figure 52 and Figure 53) These lenses will need to be cleaned if they get a build-up on them that can interfere with the sending and receiving of the Infra Red light. Simply slide the Lenses out of the brackets and clean them with glass cleaner. Use caution not to get fingerprints on the glass when putting the lens back in place. **DO NOT USE ALCOHOL ON THE SENSOR, IT MAY CLOUD THE LENS.**

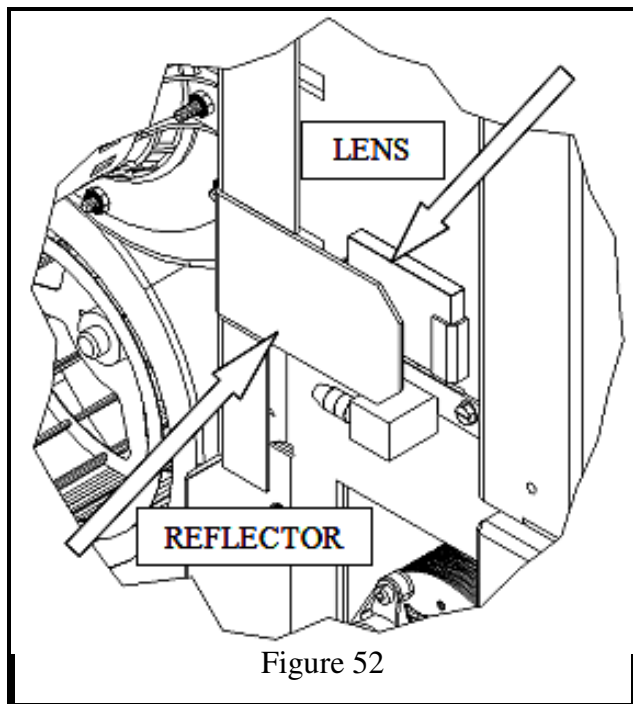

Figure 52

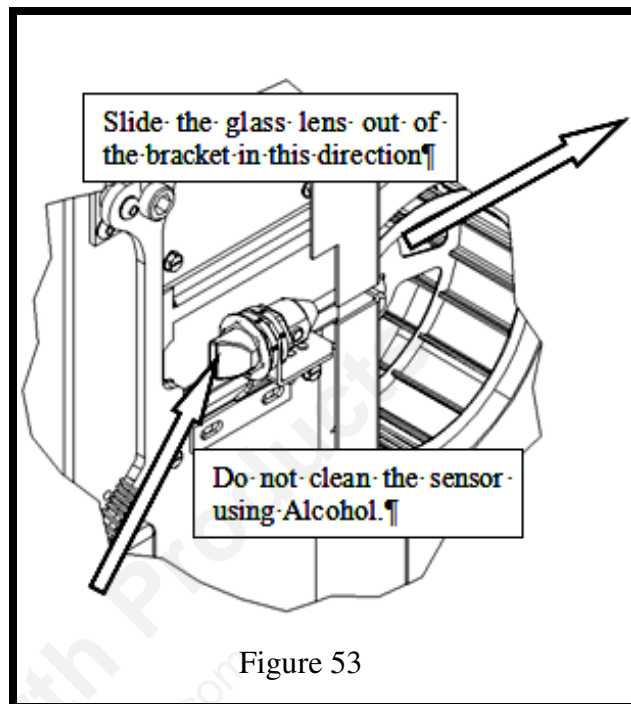

Figure 53

7. **My Stove isn't burning and the #5 LED light is on Solid (not blinking).** When the stove is in "Idle Mode" (Not Burning) the control board monitors the Rotation Sensor Switch (see Figure 24 & Figure 34). In "Idle Mode" the switch should be resting in the notch of the disc. The #5 LED light being on solid usually means that the Drum in the pot is jammed and out of position.

The Drum rotating continuously will indicate that the Rotation Sensor switch is not functioning correctly or there is a wiring problem.

8. **I turned the Stove on with the On/Off switch and nothing happens.** First check to see if the Stove is plugged in and the receptacle has power to it.

**Solution:** Check the fuse on the back of the control board. Replace with a 125 Volt, 5 Amp fuse.

Is the stove connected to a Thermostat and running is SmartStat Mode? If so, is the Thermostat calling for heat? Turn the Thermostat up to see if the stove on.

9. **Why is my glass dirty?** Normal operation of your St. Croix Corn/Pellet Stove will produce a white build-up on the glass that wipes off with a dry paper towel. However extended burning on the low setting only will produce a tan color. These types of build-up on the glass are normal. A heavy shiny black build-up on the glass could indicate a problem (too much combustion air).

**Solution:** Adjust the combustion air setting to the proper setting, using the damper or the Draft settings on the Board, or a combination of both. It also could be an indication that the Stove is getting plugged and needs a good cleaning. Refer to the section in the manual that covers the Daily, Periodic and Yearly Maintenance of the Stove.

10. Are there any adjustments that can be made, through the control board, to the amount of fuel that is fed into the burnpot?

Answer: There are several ways to adjust the amount of fuel that is fed into the burnpot. The feed rates can be fine-tuned while the Stove is in operation by **pressing and holding** the “Auger Feed” button down and then **either** pressing and releasing the “Heat Level High” button to advance the feed rate higher, **or** pressing and releasing the “Heat Level Low” button to decrease the feed rate.

There are 5 levels on the control board and they are indicated by a single flash of the LED’s. The default setting is the center LED. This gives 2 adjustments increasing the feed rate (LED’s 4 & 5) and 2 adjustments decreasing the feed rates. (LED’s 1 & 2) The ON time is **increased or decreased** .25 seconds with each adjustment.

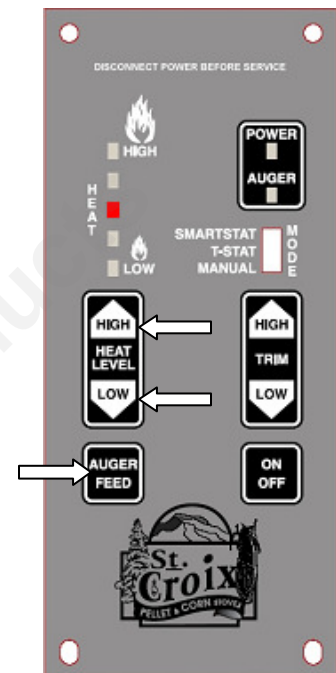

Figure 54

11. Are there any adjustments that can be made, through the control board, to the Combustion Fan voltages to help adjust the draft?

Answer: The Draft can be adjusted in a similar fashion as mentioned in the previous example.

The Fan voltages can be fine-tuned while the Stove is in operation by **pressing and holding** the “Auger Feed” button down and then **either** pressing and releasing the “Draft Trim High” button to advance the voltages higher, **or** pressing and releasing the “Draft Trim Low” button to decrease the fan voltages.

There are 5 levels on the control board and they are indicated by single flash of the LED’s. The default setting is the center LED. This gives 2 adjustments increasing the voltage (LED’s 4 & 5) and 2 adjustments decreasing the voltage. (LED’s 1 & 2) The voltage is **increased or decreased** 2.5 volts with each adjustment.

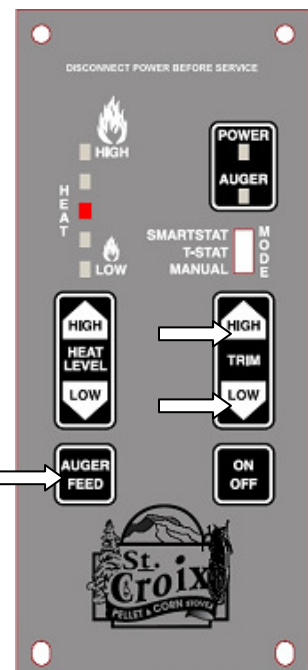

Figure 55

12. **Are there Cycle Time adjustments on the Control Board for different types of fuel?**

Answer: There are 4 individual programs on the control board, each with a different Cycle time.

The Control board has been factory set at the 7.5-second Cycle Time. When reprogramming the control board, you will see all of the LED lights flash, as shown in the figure to the right. The LED lights flash in the following manner:

**Program 1 - 7.5 second cycle time.** The LED's flash **once**. This program is for use with Pellets & Cherry Pits.

**Program 2 - 8.5 second cycle time.** The LED's flash **twice**. This program is for use with Pellets, Cherry Pits and Corn.

**Program 3 - 9.5 second cycle time.** The LED's flash **three times**. This program is for use with Pellets, Cherry Pits, Corn, Wheat, Rye, and Distillers Grain.

**Program 4 - 10.5 second cycle time.** The LED's flash **four times**. This program is for use with Pellets, Cherry Pits, Corn, Wheat, Rye, and Distillers Grain.

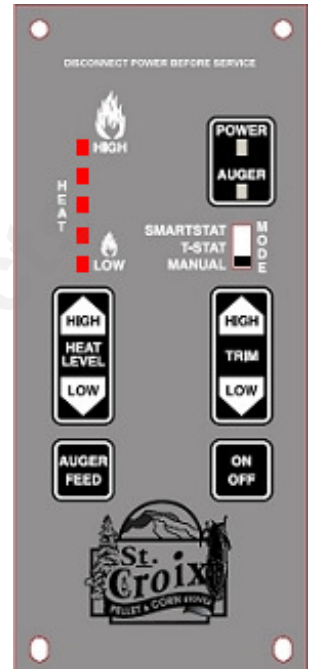

Figure 56

13. **How do I change to a different Program on the control board?**

First the Stove must be turned off and cooled down.

Step 1 - The Thermostat switch must be in the **Manual** position.

Step 2 – Press and hold the **Auger Feed** Button.

Step 3 – Press and hold both of the **Draft Trim** High and Low Buttons. Release all 3 buttons at the same time.

Step 4 – Observe the LED light flashing as described in point 10 above.

Changing the Cycle Time will change the BTU Input of the Stove. The longer the Cycle time the lower the BTU rating.

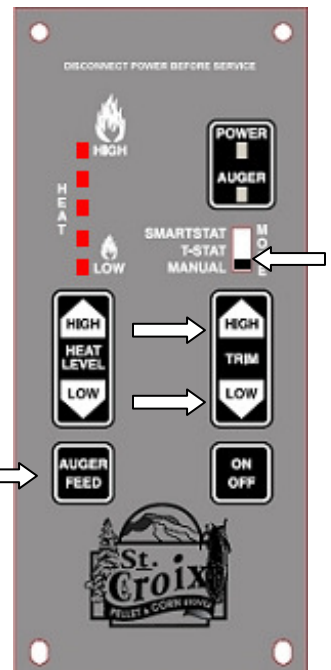

Figure 57

## LINCOLN SCR WARRANTY

The Stove manufactured by Even Temp, Inc. is warranted for five (5) years, to the original owner, against defects and workmanship on all steel parts (excluding the burn grate, Baffle and Brick Panels) and two (2) year on electrical components from the date of sale to the original owner. There specifically is no warranty on the paint, glass and all gaskets. There is no written or implied performance warranty on the Stove, as the manufacturer has no control over the installation, daily operations, maintenance or the type of fuel burned.

This warranty will not apply if the Stove has not been installed, operated and maintained in strict accordance with the manufacturer's instructions. Burning other than approved quality fuels may cause Stove damage and could void the warranty.

The warranty does not cover damage or breakage due to misuse, improper handling or modifications.

A warranty registration card is provided. The card is to be checked and signed and returned to factory by the owner. Appropriate information is to be noted on the card.

All claims under this warranty must be made through the dealer where the Stove was purchased. If an inspection by the dealer indicates that a warranty claim is justified, and that all conditions of this warranty have been met, the manufacturer's total responsibilities and liabilities shall be to repair or replace, at the manufacturer's option, the defective part(s). All costs of removal, shipment to and from the dealer or manufacturer, any losses during shipment and reinstallation and any other losses due to the Stove being removed shall be covered by the owner of the Stove.

NEITHER THE MANUFACTURER, NOR THE SUPPLIERS TO THE PURCHASER, ACCEPTS RESPONSIBILITY, LEGAL OR OTHERWISE, FOR THE INCIDENTAL OR CONSEQUENTIAL DAMAGE TO PROPERTY OR PERSONS RESULTING FROM THE USE OF THIS PRODUCT. ANY WARRANTY IMPLIED BY LAW, INCLUDING BUT NOT LIMITED TO IMPLIED WARRANTIES OF MERCHANTABILITY OR FITNESS, SHALL BE LIMITED TO ONE (1) YEAR FROM THE DATE OF ORIGINAL PURCHASE. WHEN A CLAIM IS MADE AGAINST THE MANUFACTURER BASED ON THE BREACH OF THIS WARRANTY OR ANY OTHER TYPE OF WARRANTY EXPRESSED OR IMPLIED BY LAW, MANUFACTURER SHALL IN NO EVENT BE LIABLE FOR ANY SPECIAL, INDIRECT, CONSEQUENTIAL OR OTHER DAMAGES OF ANY NATURE WHATSOEVER IN EXCESS OF THE ORIGINAL PURCHASE PRICE OF THIS PRODUCT. ALL WARRANTIES BY MANUFACTURER ARE SET FORTH HEREIN AND NO CLAIM SHALL BE MADE AGAINST MANUFACTURER ON ANY ORAL WARRANTY OR REPRESENTATION.

Some states do not allow the exclusion or limitation of incidental or consequential damages, or limitations of implied warranties; therefore the limitations of exclusions set forth in this warranty may not apply to you. This warranty gives you specific legal rights, and you may have other rights, which vary from state to state.

## Notes:

After the break in period, please note any adjustments that were made to the Feed Trim and Draft Trim on the control board in the area below. In the event of a power failure or if the units gets unplugged the trim settings will be lost.

**Draft Trim: Circle one (See point 4a on page 37)**

**LED #1            LED #2            LED #3            LED #4            LED #5**

**Feed Trim: Circle one (See point 4b on page 37)**

**LED #1            LED #2            LED #3            LED #4            LED #5**

**FUEL: Circle One**

**PELLETS – CORN – WHEAT - RYE - CHERRY PITS - DISTILLER’S GRAIN**

**PROGRAM: Circle one (see Figure 32 on page 41)**

**1                    2                    3                    4**

Serial Number:

Date of Purchase:

Dealer Information:

**Even Temp, Inc.**  
**P.O. Box 127**  
**Waco, NE 68460**

**EMAIL: [support@stcroixstoves.com](mailto:support@stcroixstoves.com)**

**WEB ADDRESS: [www.stcroixstoves.com](http://www.stcroixstoves.com)**