

# Installation & Operation Manual

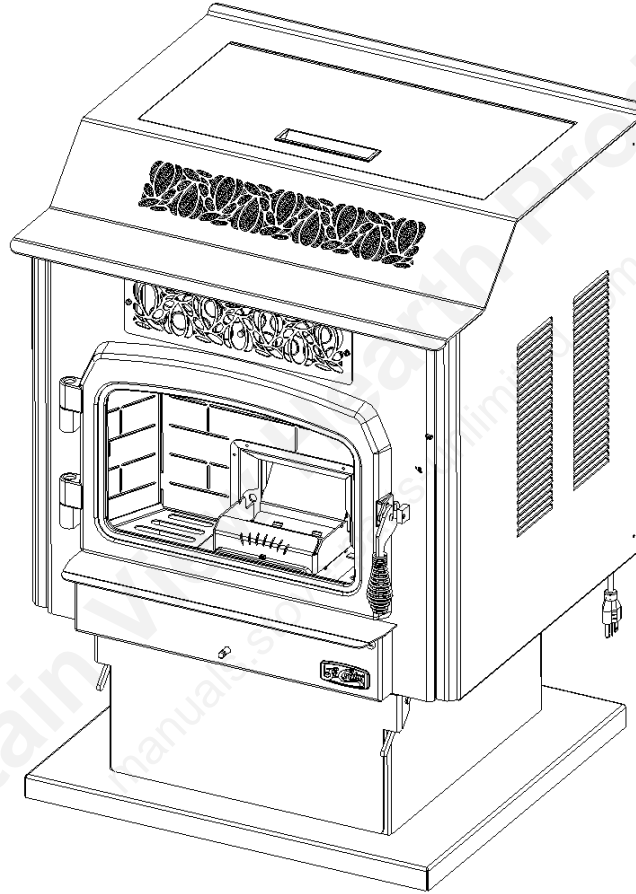

## Prescott Series



"Please read this entire manual before installation and use of this pellet fuel-burning room heater. Failure to follow these instructions could result in property damage, bodily injury or even death."

"Contact local building or fire officials about restrictions and installation inspection requirements in your area."

Save these Instructions  
515

# TABLE OF CONTENTS

General Information .....	4
Installation Check List .....	5, 6
Prescott Series Layout Diagram.....	7, 8
Prescott Series Dimensions.....	9, 10
Approved Installations .....	10
Exhaust Venting: Approved Materials.....	11
Venting – Typical PL Vent Components .....	12
Venting - Determining Materials .....	13
Venting - Termination Requirements.....	14, 15
Venting: Termination Clearance Requirements .....	16
Venting – Installations.....	17, 18
Floor Protection .....	19
Minimum Clearances .....	20, 21
Outside Combustion Air .....	22
Mobile Home Installation .....	23
Prescott Series Operation.....	24
Preventing Chimney Fires.....	24
Prescott Series Approved Fuels .....	24
Installation Check .....	25, 26
Control Board Features.....	26, 27
Pre-Lighting & Lighting instructions.....	27-29
Shutting Off the Insert .....	29, 30

Importance of Proper Draft.....	30
Initial Damper Settings .....	30
Flame Pattern Characteristics .....	31
Use of a Thermostat .....	32, 33
Thermostat Control & Pilot Settings.....	33
Diagnostic Features.....	33, 34
Safety Features .....	34, 35
Prescott Series Maintenance .....	35
Versa Grate System.....	36
Daily Maintenance (Versa Grate System) .....	37-38
Periodic Maintenance.....	38-40
Yearly Maintenance .....	40, 41
Safe Operation .....	41
Wiring Schematic.....	42
<b>Troubleshooting &amp; Frequently Asked Questions .....</b>	<b>43-46</b>
Prescott Series Parts Breakdown .....	47-49
Warranty .....	50
Prescott Series Info & Notes.....	51

**Even Temp, Inc.**  
**P.O. Box 127**  
**Waco, NE 68460**

**EMAIL:** [info@eventempinc.com](mailto:info@eventempinc.com)

**WEB ADDRESS:** [www.stcroixstoves.com](http://www.stcroixstoves.com)

# Save This Installation & Operations Manual

## GENERAL INFORMATION SAFETY PRECAUTIONS

***SAFETY NOTICE: The Prescott EXP and Prescott EXL must be properly installed in order to prevent the possibility of a house fire! These installation instructions must be strictly observed! The Maintenance schedule must be followed as described in this manual. Failure to follow instructions may result in property damage, bodily injury or even death.***

The stove's exhaust system works with negative combustion chamber pressure and a slightly positive chimney pressure. Therefore, it is imperative that the air intake and exhaust system be airtight and installed correctly. Do not install a flue damper in the exhaust vent of this unit.

Do not connect this unit to a chimney flue serving another appliance.

### BUILDING PERMIT

Contact the local building officials to obtain a permit and information on any local installation restrictions and inspection requirements.

### DEFINITION OF "STOVE"

The word "Stove" as used in this manual to describe the Prescott Series is interpreted to mean a Stove approved for PFI Premium pellets. **This stove is not intended as the sole source of heat.**

### EMISSIONS TESTING

U.S. ENVIRONMENTAL PROTECTION AGENCY Certified to comply with 2020 particulate emission standards using pellet fuel.

Certified to the 2020 Phase of ASTM E2779-2010. Heat Output: 8033 BTU/hr – 29861 BTU/hr, Efficiency: 70.1% using the higher Heat Value of the Fuel. Emission Rate .538 gr/h

### SAFETY TESTING

The Prescott EXL and Prescott EXP have been independently tested and listed by Warnock Hersey Laboratories in accordance with the proposed ASTM E 1509-2004 Standards and the applicable portions of UL 1482 and ULC S627/B366.2, and Oregon Administrative Rules 814-23-901 through 814-23-909, stating requirements for installation the Prescott EXP and the Prescott EXL for mobile home installations. The safety-listing label is located on the back of the stove. Please refer to label for pertinent information.

### DISCLAIMER OF WARRANTY

Since Even Temp Company has no control over the installation of the Prescott EXP or Prescott EXL, Even Temp Company grants no warranty, implied or stated, for the installation of the unit and assumes no responsibility for any special, incidental or consequential damages.

### MANUFACTURED BY:

Even Temp Inc  
Hwy 34, Waco, NE, 68467  
Phone: 1-402-728-5255

## INSTALLATION CHECK LIST

- FOR USE IN THE U.S. AND CANADA
- MOBILE HOME APPROVED
- CHECK WITH LOCAL AUTHORITIES AND OBTAIN NEEDED PERMITS. OBTAIN FINAL INSPECTION FROM LOCAL BUILDING OFFICIALS.
- WE RECOMMEND INSTALLATION BY A QUALIFIED PROFESSIONAL OR DEALER.
- ADHERE TO ALL CLEARANCES SPECIFIED BY THE MANUFACTURER OF THE VENTING SYSTEM USED.
- ADHERE TO ALL CLEARANCES SPECIFIED IN THE INSTALLATION INSTRUCTIONS OF THIS STOVE.
- THIS STOVE USES A POSITIVE PRESSURE VENTING SYSTEM. DO NOT INSTALL A FLUE DAMPER IN THE EXHAUST SYSTEM OF UNIT.
- DO NOT CONNECT THIS STOVE TO A CHIMNEY SYSTEM THAT IS CONNECTED TO ANOTHER APPLIANCE.
  
- DO NOT INSTALL THIS UNIT IN A SLEEPING ROOM.
- INSTALL A SMOKE DETECTOR IN PROXIMITY OF THE STOVE.
- INSTALL A CARBON MONOXIDE DETECTOR IN PROXIMITY OF THE STOVE

### ATTENTION

- **CONDENSATION:** When planning the installation of your Stove, keep in mind that condensation is detrimental to exhaust systems. Install the Stove with a minimum of the vent system exposed to the cold temperatures outside the envelope of the house.
- **BATTERY BACKUP:** St Croix does not offer battery backups. They are available online if you decide to use one. Battery backup systems are useful if the Stove is installed using horizontal venting only. This prevents any smoke from entering your home in the event of a power failure.
- **OPTIONAL EXHAUST FAN RELAY KIT:** With optional relay kit 80P54232 installed in the stove and connected to an inexpensive UPS battery backup (not part of the kit) you will have maximum protection against smoke leaking out of the stove in the event of a power failure. This is considered the best installation when venting horizontally. Contact your dealer for more information.

1. All joints of PL vent and single wall stainless steel pipe should be fastened by at least 3 screws and correctly installed. (Follow vent manufacturer's instructions). Seal all joints with high temperature silicone to create an airtight seal.

2. A certain amount of carbon monoxide may be produced within the Stove as a by-product of combustion. All exhaust vent connections must be sealed with **RTV silicone** to assure a gas tight seal. **Any leaks into a confined area caused by faulty installation or improper operation of the Stove could produce dizziness, nausea and in extreme cases, death.** The CO concentration in the flue gas during the testing was found to be too low and under the accuracy of the test equipment used for the flue gas analysis. Therefore, the CO emissions could not be calculated.

3. **WARNING:** The high temperature paint on this Stove may take several hours of burning at a high fuel setting to cure fully. During this time, an odor that is not harmful may be evident. When odors are present, the area around the Stove should be well ventilated.

4. **Caution:** The high temperature paint can be easily scratched prior to burning the Stove.

5. Have your dealer demonstrate all the operational and maintenance steps necessary for proper use of the Stove. **Sign and return the warranty card** to the address listed on the back page.

6. Some odors may be given off during the first few hours of burning during initial break-in. These odors are normal and not harmful. However, ventilating the room until the odors disappear is recommended.

7. The Stove will become **HOT** while in operation. Keep clothing and furniture away from all hot surfaces.

8. To avoid the possibility of smoke and/or sparks entering the room always keep firebox and ash pan doors closed whenever the Stove is operating. Smoke detectors, installed in the same general area as the Stove, may be activated if the Stove door is left open and smoke is allowed to enter the area.

9. Under certain circumstances an outside source of combustion air may be needed and is required on all mobile home installations. Use only approved parts. When using outside air for combustion, check that the outside air inlet is connected to draw fresh air from outside the building. If room air is used to supply combustion air, room air starvation (not enough make-up air), operation of exhaust fans and icing of air vents can adversely affect proper Stove operation.

This wood heater has a manufacturer-set minimum low burn rate that must not be altered. It is against federal regulations to alter this setting or otherwise operate this wood heater in a manner inconsistent with operating instructions in this manual.

**CAUTION: FAILURE TO FOLLOW THE INSTRUCTIONS IN THE INSTALLATIONS MANUAL MAY RESULT IN A HOUSE FIRE, PROPERTY DAMAGE, BODILY INJURY, OR EVEN DEATH. PLEASE FOLLOW INSTALLATION AND MAINTENANCE INSTRUCTIONS.**

**CAUTION: NEVER ADD FIRE STARTER TO A HOT STOVE.**

**CAUTION - Hot Surfaces**

**- Keep Children away.**

**- Do not touch during Operation.**

# Prescott Series Stove Layout

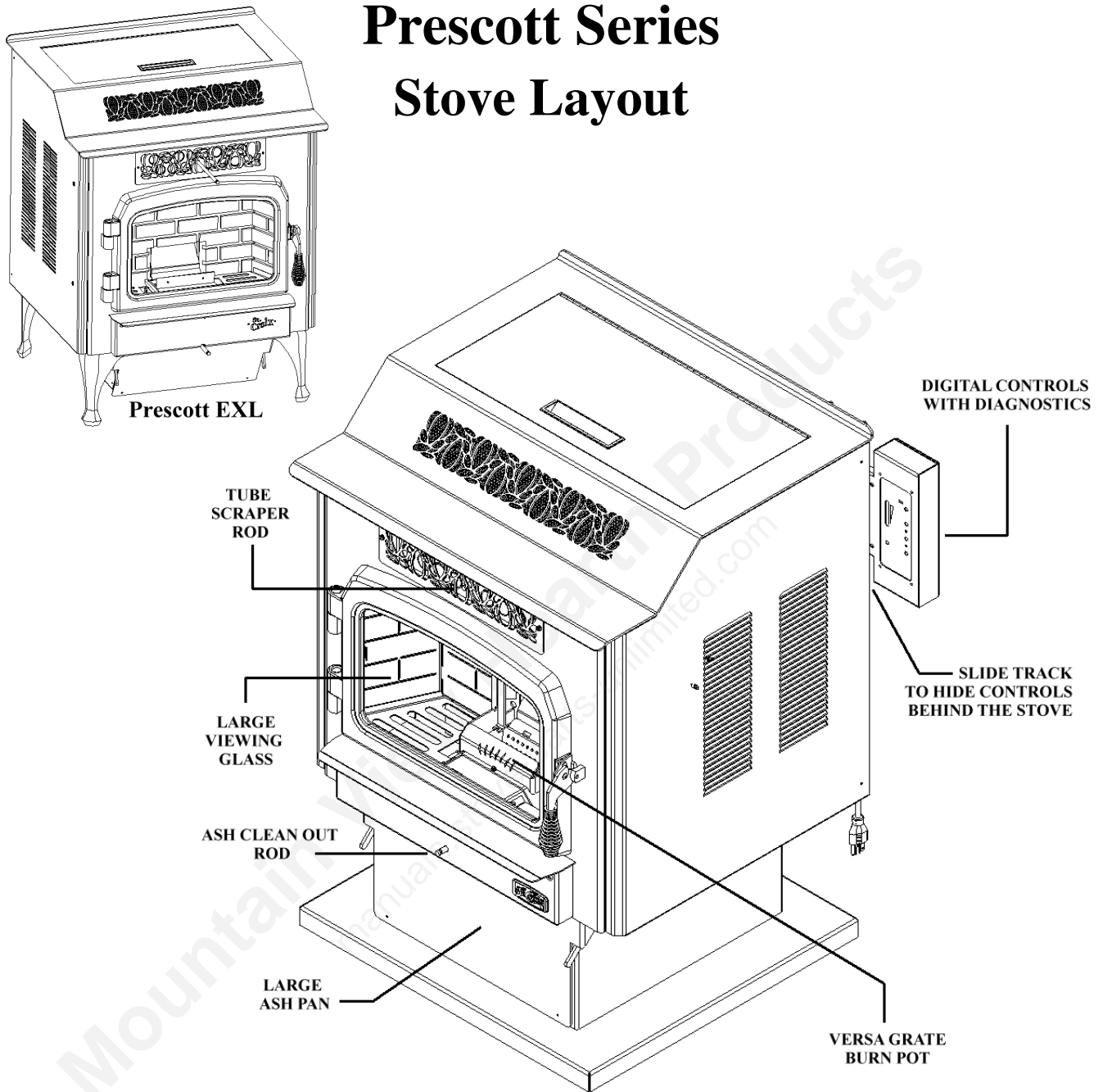

Figure 1

There are two burn systems used in the Prescott/Auburn Series. These systems are interchangeable in the stove body. This Manual covers the Prescott EXP and Prescott EXL, which uses the **Versa Grate System**

The “**Versa Grate System**”: A Fully Automatic System that offers Self-Ignition. This system is approved for PFI Premium Pellets only. *See Figure 2 on the next page.*

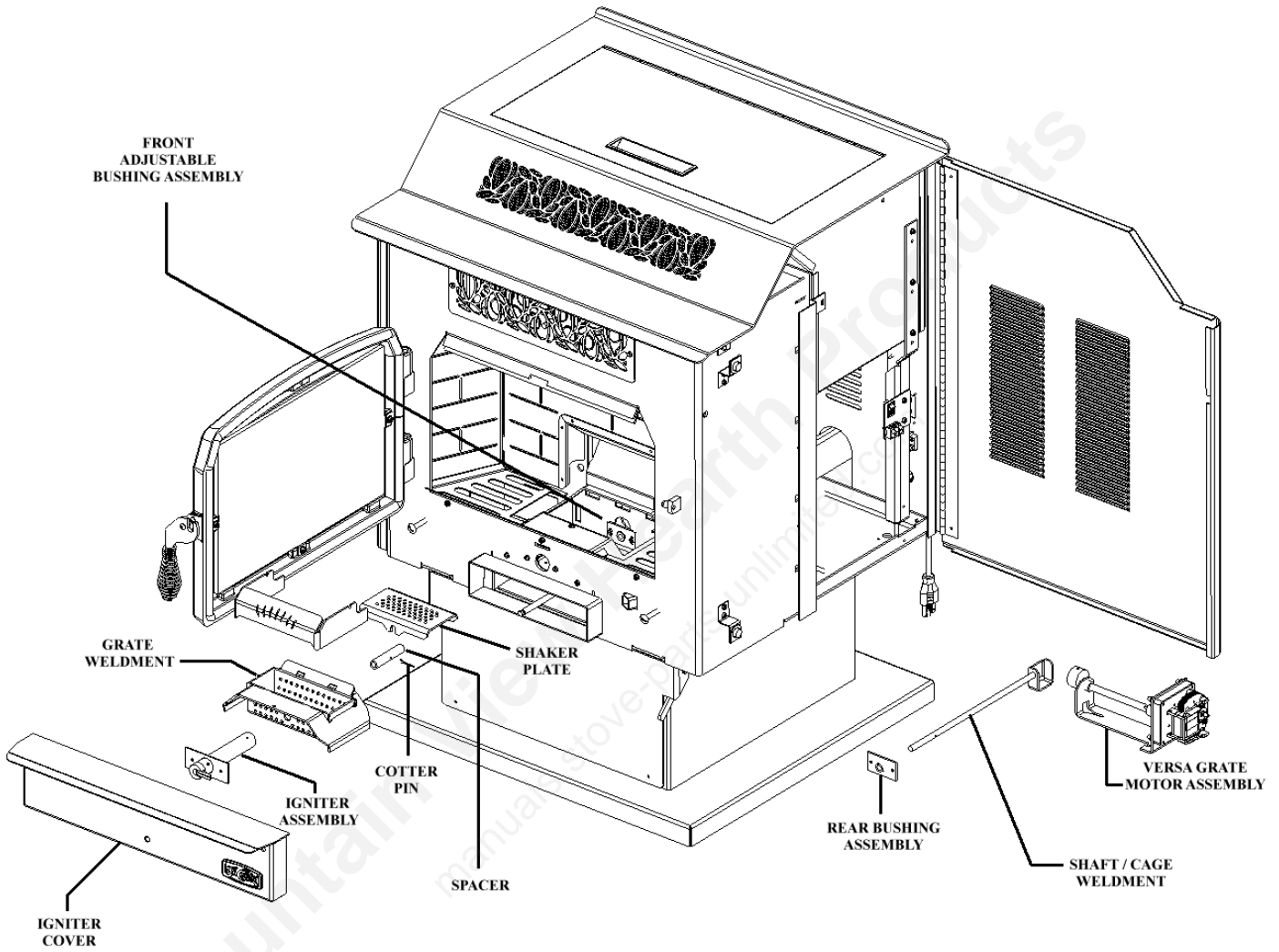

Figure 2

Versa Grate System Approved with PFI Premium Pellets only.

# PRESCOTT EXL DIMENSIONS

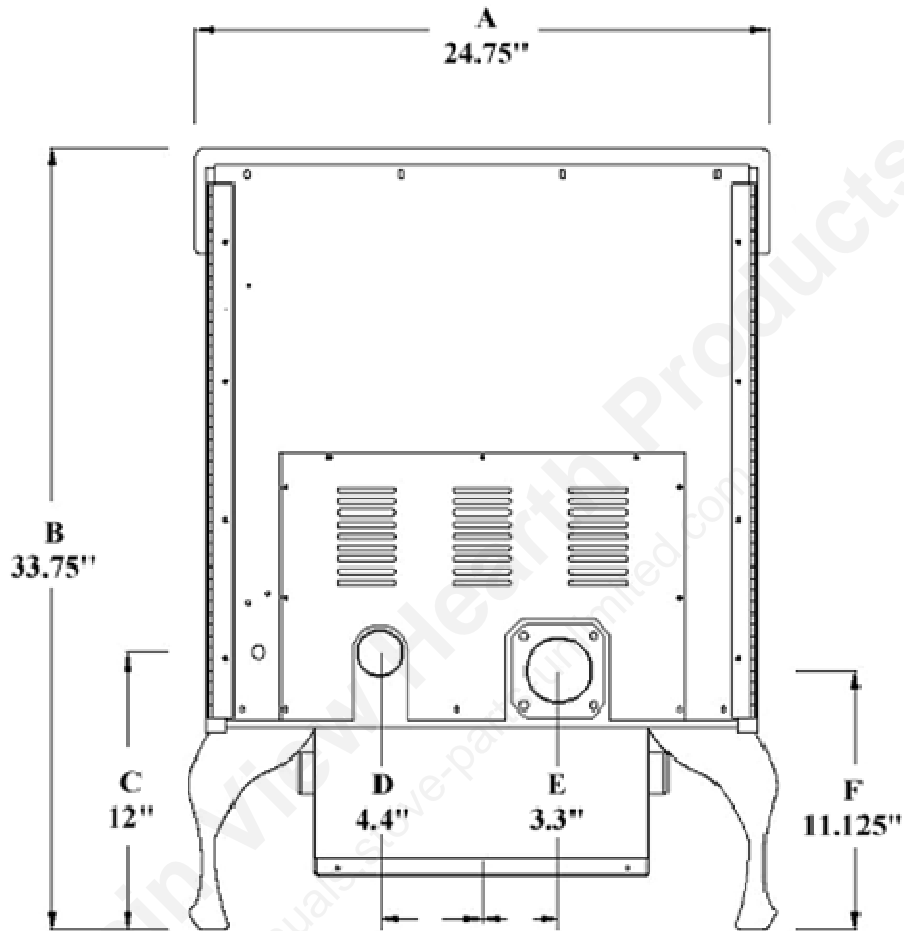

Figure 3a.

## REAR VIEW OF PRESCOTT EXL

A – Width of stove

D – Center of stove to center of intake tube

B – Height of stove

E – Center of stove to center of exhaust

C – Center of intake tube from floor

F – Center of exhaust from floor

# PRESCOTT EXP DIMENSIONS

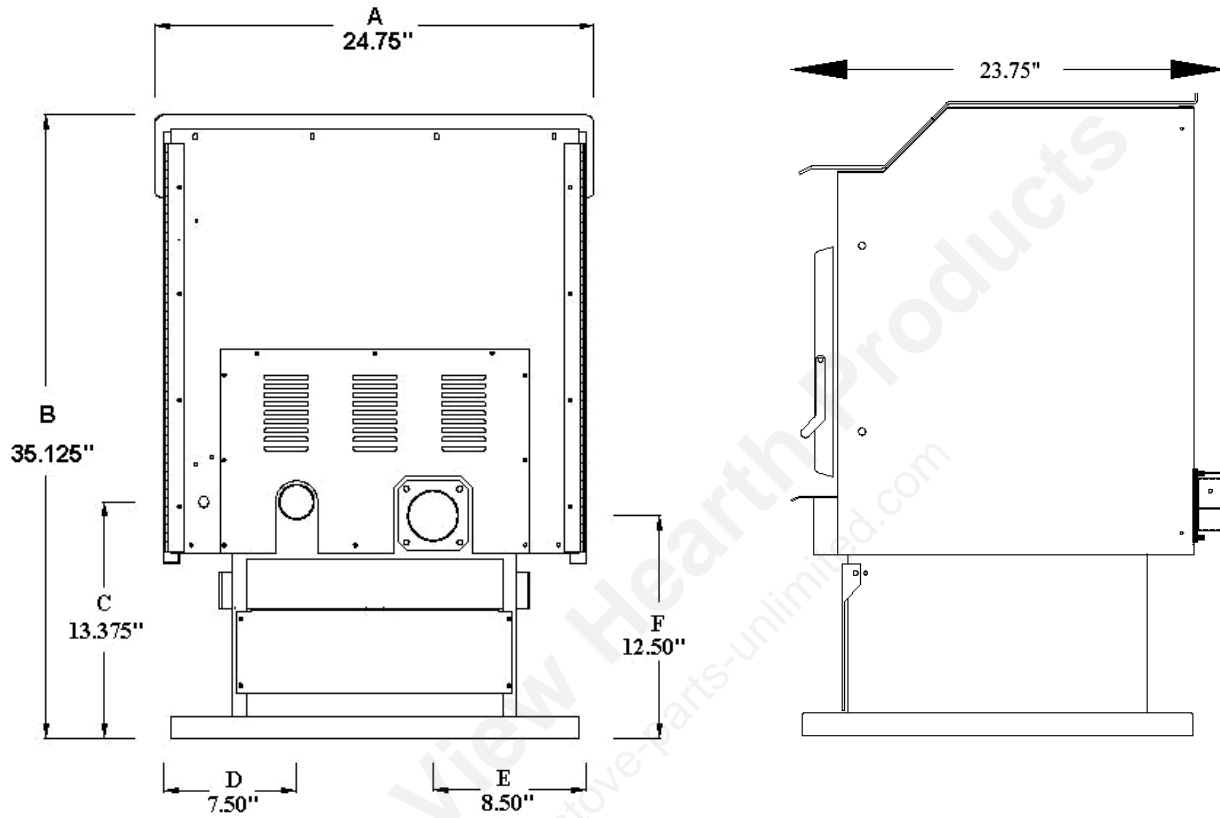

Figure 3b

- |   |   |
|---|---|
| A - Width of Stove                          | E - Center of stove to center of exhaust  |
| B - Height of Stove                         | F - Center of exhaust from Base of Stove  |
| C - Center of Air Intake from Base of Stove | G - Front of Stove to Back of Stove       |
| D - Center of Stove to Center of Air Intake | H - Front of Stove to end of Exhaust Pipe |

## Approved Installations

The Prescott Series is approved for CONVENTIONAL and MOBILE HOME installations as a FREESTANDING stove. The stove may also be installed on the Hearth in front of a Fireplace and vented through the chimney of the fireplace.

## VENTING: APPROVED MATERIALS

The Stove requires a venting system approved for pellet or corn venting by a certified testing lab. Approved pellet or corn venting materials are: 1) PL vent, a double wall vent with a stainless steel liner; and 2) Single wall rigid or flexible stainless steel pipe. PL Vent and Single wall vent is available through manufacturers such as: ICC Pellet Vent, Energy Vent LTD, James A. Ryder, Simpson Dura Vent and Selkirk Metalbestos and is carried by many local dealers. In this manual approved venting will be referred to a “PL vent” or “Single wall vent”. All single wall vent adaptors must be stainless steel.

NOTE: TYPE “B” GAS VENT MUST NOT BE USED IN THE INSTALLATION OF THIS PELLET STOVE.

### Venting size Guidelines

Type of Installation:	Size:	:
A. Less than 10’ horizontal:	3”	Acceptable
B. 10’ to 12’ horizontal:	3” or 4”	Acceptable
C. Over 12’ horizontal:	4”	Required
Horizontal installation over 12’ is NOT RECOMMENDED		
D. Less than 15’ vertical:	3”	Acceptable
E. Over 15’ vertical:	4”	Required
F. Above 4000’ elevation:	3” or 4”	Acceptable

**Note: Four (4) inch vent may be used in all installations. If in doubt, use 4” vent.**

Examples of venting system components follow:



High temperature ceramic roping reduces potential fly ash escaping through joints.

Stainless steel inner liners resist corrosive flue gas damage to the system.

Flex pipe should be stainless steel, 4 ply construction with a total thickness of approximately .07 inches.

## TYPICAL PL VENT COMPONENTS



*RAIN CAP  
VERTICAL OR  
HORIZONTAL*



*WALL THIMBLE*



*CHIMNEY  
ADAPTER*



*SUPPORT BRACKET*



*ADJUSTABLE LENGTH  
PIPE*



*SINGLE TEE  
w/TEE CAP*



*SINGLE REDUCTION  
TEE w/TEE CAP*



*DOUBLE TEE  
w/TEE CAP*



*PIPE ADAPTER*



*INCREASER*



*45° ELBOW*



*90° ELBOW*

## VENTING: DETERMINING MATERIALS

### TYPE OF MATERIALS:

1. *PL Vent / Corn Vent must be used.*

2. All Joints in the venting installation must be fastened together using three screws. All joints of the venting system must be sealed with High Temp Silicone to make a gas tight fit.

3. **Exception: Single wall stainless steel may be used inside an existing chimney.** (No clearances to combustibles are needed on single wall stainless steel adaptors, rigid or flex pipe installed within a chimney.)

4. A clean-out “tee” (PL Vent or “Quick-Connect Exhaust”) must be installed directly to the Stove and at the bottom of each vertical run of the exhaust system. These tees are to assist in periodically cleaning the pipe. Single or double clean-out tees may be used. **The exhaust system must be installed so the entire system can be cleaned without disassembly.**

NOTE: ADHERE TO THE PL VENT CLEARANCES TO COMBUSTIBLES AS REQUIRED. STRICTLY OBSERVE THE PL VENT MANUFACTURER’S SAFETY SPECIFICATIONS.

### QUANTITY OF MATERIALS:

1. It is recommended that the vent system be installed with a **minimum of three feet (3’) of vertical rise** above the exhaust port on the back of the stove.

FAILURE TO PROVIDE THE NATURAL DRAFT THAT RESULTS FROM A VERTICAL RISE MAY RESULT IN SMOKE BEING RELEASED INTO THE HOUSE WHEN ELECTRICITY TO THE UNIT IS INTERRUPTED WHILE BURNING OR SMOLDERING FUEL REMAINS IN THE BURN GRATE. (*See “Battery Backup” on page 5*)

2. It is not recommended to run vertical venting outside the heated environment where the stove is installed. Running a venting system in a cold environment may cause the flue temperatures to cool down too much for adequate drafting.

Additional vertical exhaust venting should be provided when using:

a. More than one (1) elbow or tee; and/or

b. Horizontal runs of over three (3) feet. (*Horizontal runs over 10 feet not recommended*)

3. For a venting system ending in a horizontal run, the exhaust pipe must be terminated by a listed end cap or a PL vent elbow (45 or 90 degrees). Note: End caps or elbows must vent exhaust gases away from the building.

4. For termination above the building roofline a rain cap is required.

5. The exhaust pipe on the Prescott Models is 3” O.D. to accommodate a pipe adaptor.

## VENTING: TERMINATION REQUIREMENTS

In determining optimum vent termination, carefully evaluate external conditions especially when venting directly through a wall. Since you must deal with odors, gases, and fly ash, consider aesthetics, prevailing winds, distances from air inlets and combustibles, location of adjacent structures and any code requirements.

1. Exhaust must terminate above combustion air inlet elevation.
2. Do not terminate vent in any enclosed or semi-enclosed area, (i.e. Carports, garage, attic crawl space, etc.) or any location that can build up a concentration of fumes.
3. Vent surfaces can get hot enough to cause burns if touched by children. Non-combustible shielding or guards may be required

**The type of installation must first be considered before determining the exact location of the venting termination in relation ship to doors, window, cavities or air vents.**

- a. **Without** Outside Air connected to the unit. For These types of installations please refer to the dimensions listed below in figure 4.

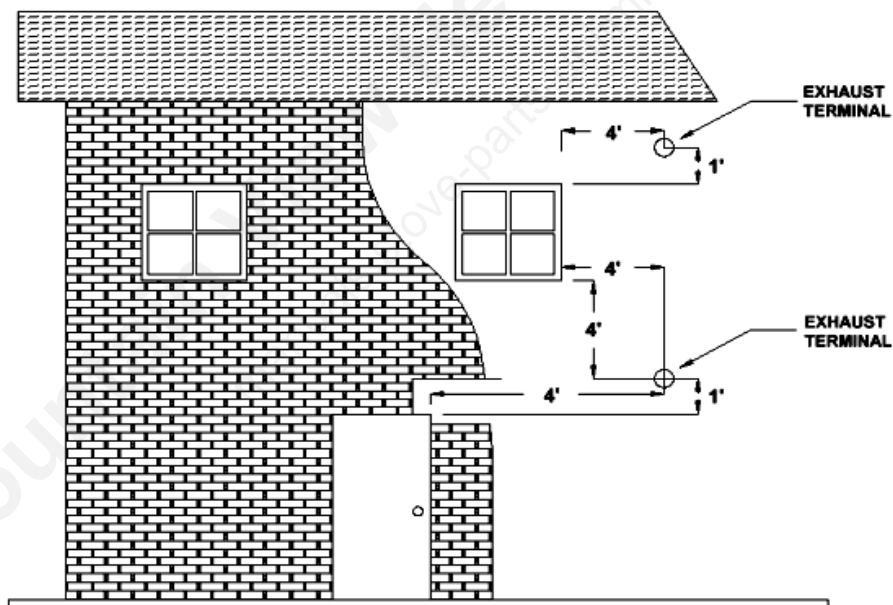

Figure 4

- |                              |                                     |
|------------------------------|-------------------------------------|
| 4' (1.2 m) BELOW             | a door, window, cavity, or air vent |
| Or                           |                                     |
| 4' (1.2 m) HORIZONTALLY FROM | a door, window, cavity, or air vent |
| Or                           |                                     |
| 1' (305 mm) ABOVE            | a door, window, cavity, or air vent |

b. **With** Outside Air Connected to the unit. In this manner the appliance is a Direct Vent Appliance (sealed Combustion System) as listed in NFPA 211-6.

3.3.3.2 *Direct Vent Appliance (Sealed Combustion System Appliance)* A system consisting of an appliance, combustion air and flue gas connections between the appliance and the outside atmosphere, and a vent cap supplied by the manufacturer, and constructed so that all the air for combustion is obtained from the outside atmosphere and all flue gases are discharged to the outside atmosphere.

Special Venting Arrangements are listed in NFPA 211-31

10.7.1.2 *The Vent Terminal of a Direct Vent Appliance with an input of 10000 BTU/Hr or less shall be located at least 6" from any opening into a building, and such an appliance with an input of over 10000 BTU/Hr, but not over 50000 BTU/Hr shall not be located less than 9" from any opening through which vent gases could enter a building, and the vent terminal of such appliance with an input over 50000 BTU/Hr shall be located not less than 12" from the opening.*

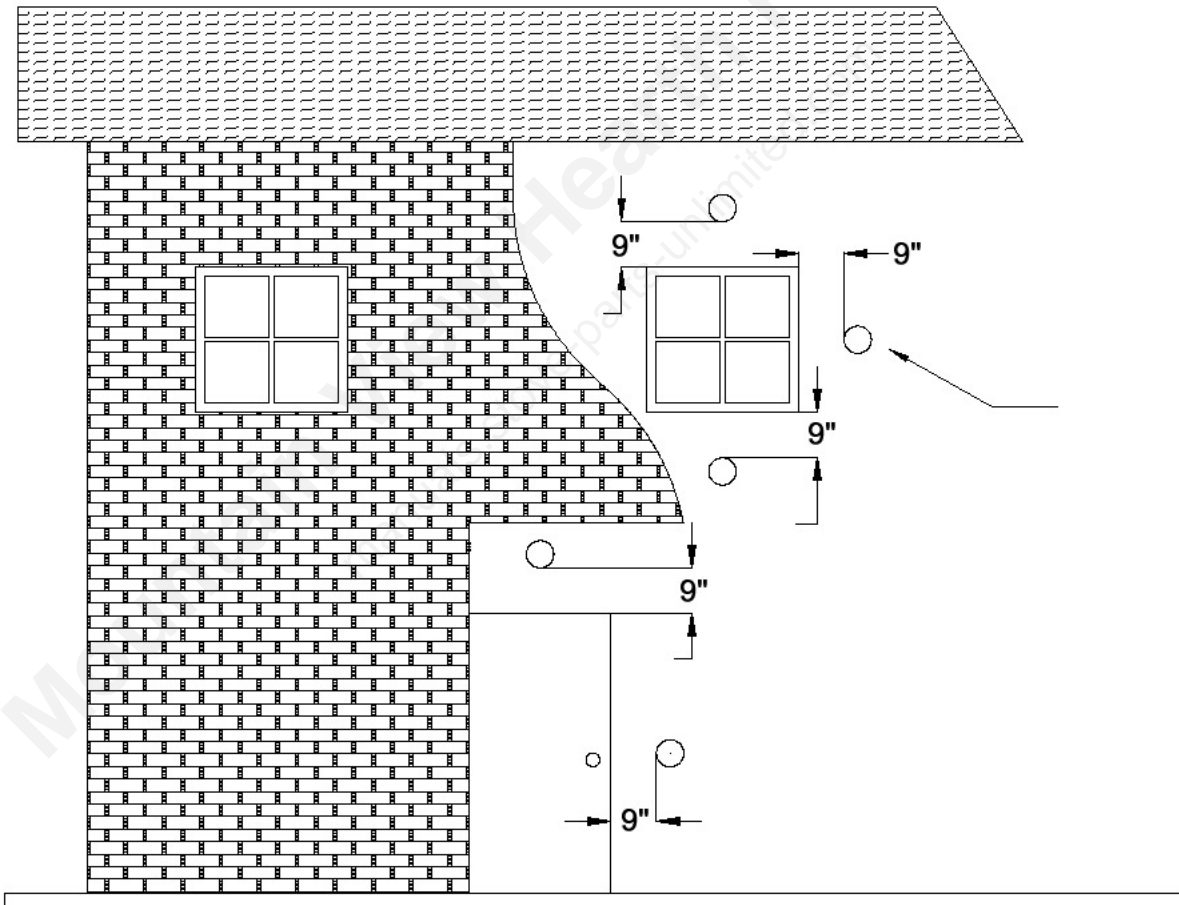

Figure 5

9" (229 mm) ABOVE, BELOW OR HORIZONTALLY FROM a door, window, cavity, or air vent.

## VENTING: TERMINATION CLEARANCE REQUIREMENTS

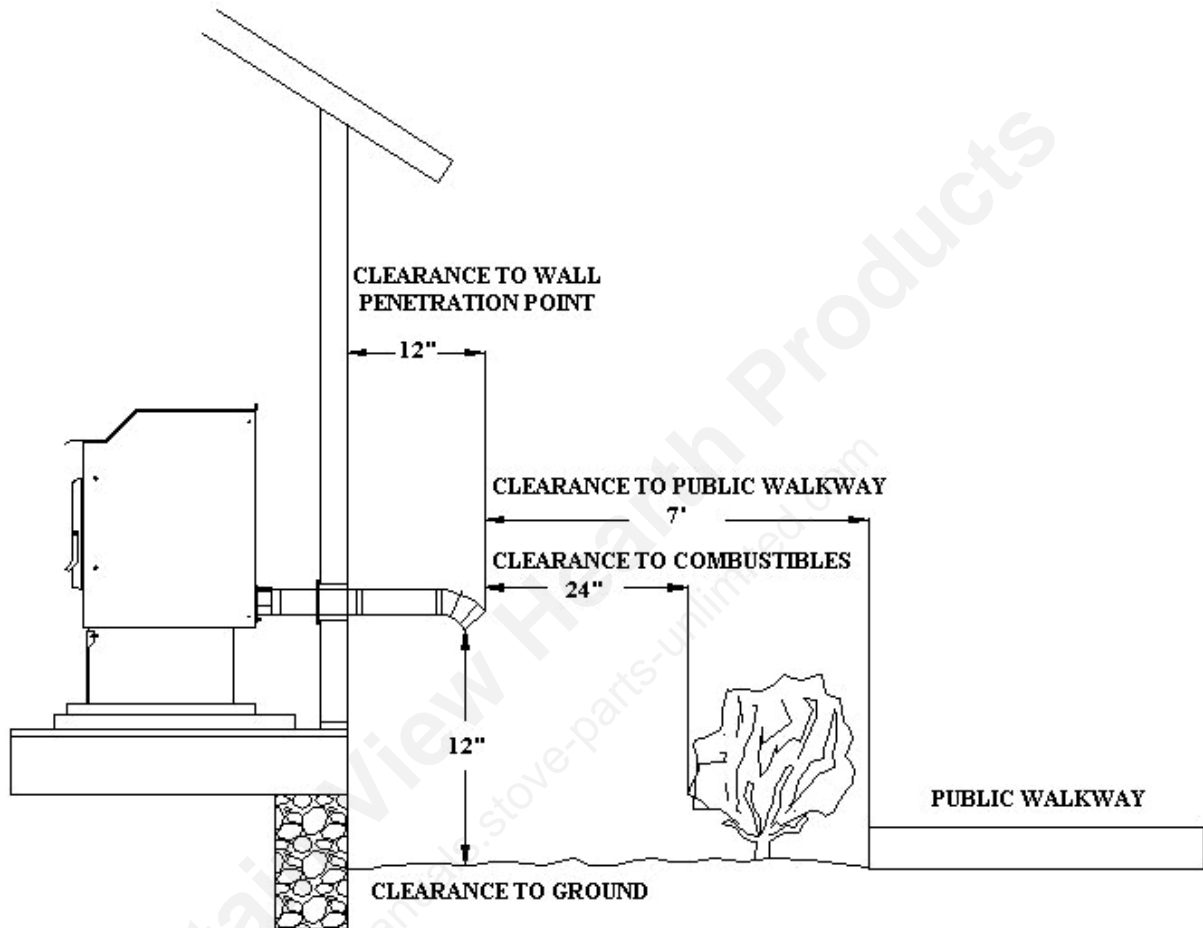

Figure 6

THE EXHAUST TERMINATION LOCATION MUST BE AT LEAST

1' (305 mm)	ABOVE the ground level
7' (2.1 m)	FROM a public walkway
1' (305 mm)	FROM The wall penetration point
3' (915mm)	FROM a gas meter/regulator assembly
2' (610 mm)	FROM any adjacent combustibles such as: Adjacent buildings, fences, protruding parts of the structure, roof eaves or overhangs, plants, shrubs, etc.

## VENTING: INTO AN EXISTING CHIMNEY

The stove may be connected to an existing Class A chimney or a masonry chimney which meets the minimum requirements of NFPA 211.

1. If the stove's exhaust is connected to a masonry chimney, the masonry chimney must be free of cracks that could leak exhaust gases or fly ash. A relining of the chimney with either PL vent or single wall stainless steel pipe may be necessary to bring the chimney into compliance.
2. When chimneys are relined, a chimney chase cap that reduces the outlet of the chimney to the size of the liner is required. Extend the exhaust vent above the chimney chase cap and finish it off with a rain cap. **A single wall liner may need to be insulated to maintain adequate exhaust temperatures in the vent system** Note: Outside Chimneys frequently are difficult to keep warm, if in doubt insulate the liner.

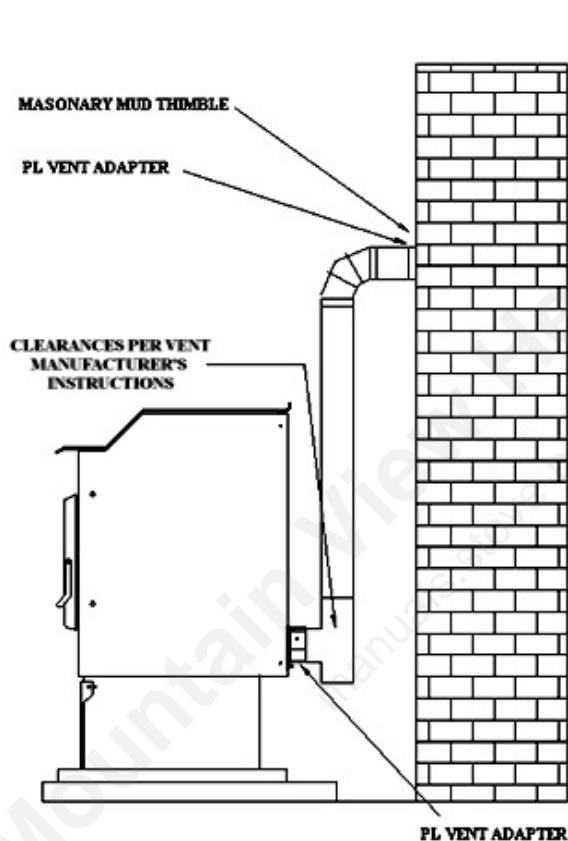

Figure 7  
Venting into Masonry Chimney

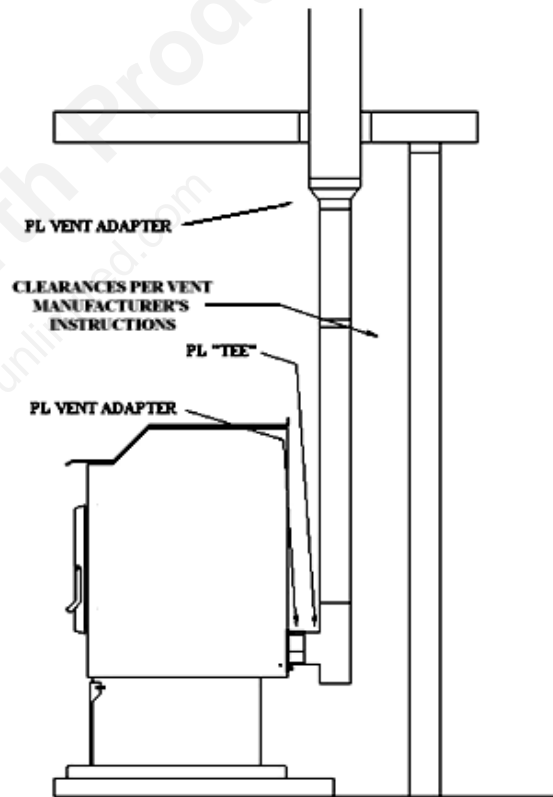
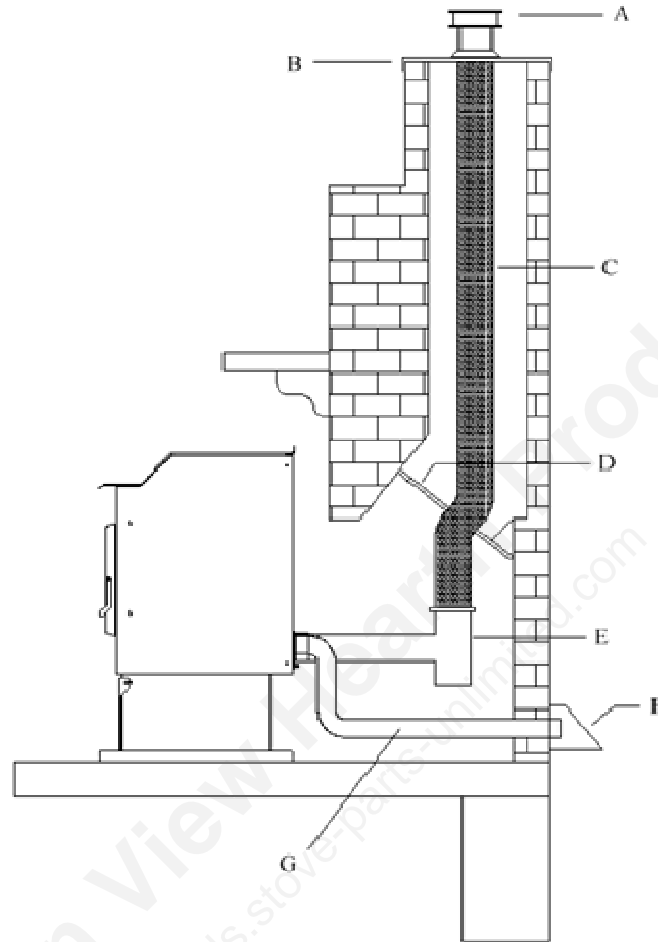

Figure 8  
Venting into Class A Chimney

3. Venting into the side of an existing masonry chimney must be done through a masonry thimble. When wall penetration is necessary to access a masonry chimney, use a listed PL vent wall thimble. (Figure 7).
4. When venting into a Class A steel chimney, use an appropriate PL Vent adapter. (Figure 8)

## Hearth Mount



### Legend

- A – Vertical Cap
- B – Chimney Flashing
- C – Stainless Steel Liner / PL Vent System
- D – Positive Block Off Plate
- E – PL Tee or Single Wall Tee
- F – Outside Air Shield – May be needed
- G – 2" Metal Outside Air Pipe - Optional

Figure 9  
Venting to the Top of Chimney

When installing as a hearth mount stove into a fireplace, the unit must either be relined terminating above the chimney chase top, or positively connected to the existing chimney system using a block off plate (C). An approved flex liner or PL vent must be used. **A chimney system with known drafting problems may require a liner, which may also need to be insulated to keep vent system warm in a cold chimney environment.**

## FLOOR PROTECTION

The stove must be installed on a Non-Combustible Surface.

Hearth models may be placed directly on the noncombustible hearth of a fireplace.

The Hearth / Non-Combustible pad must extend a minimum of 6" (152 mm) in Front of Unit *and* beyond each side of the Fuel Loading and Ash Removal Opening(s).

**Optional Spark Arrestor Pad provided with unit may only be used on a Solid Surface Floor, such as Wood Flooring, Laminate Flooring or Linoleum. Do not use on Carpet.**

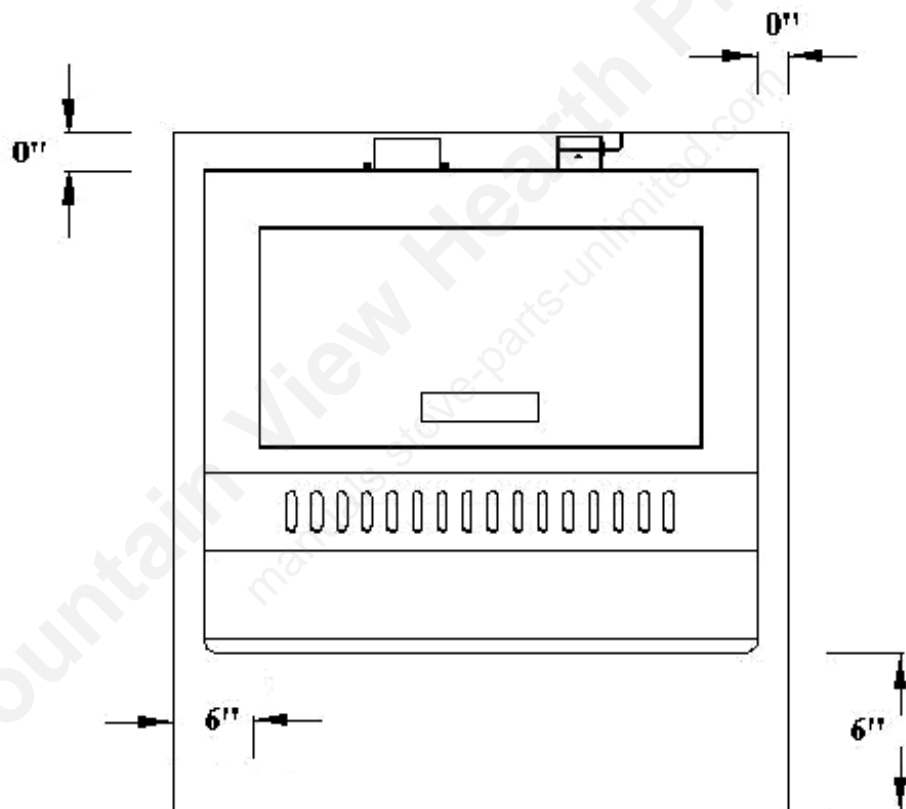

**Six inches (152 mm) beyond the front and beyond each side of the fuel and ash removal opening (s)**

Figure 10  
Floor protection  
(Top View)

## MINIMUM CLEARANCES (INCHES) TO COMBUSTIBLE MATERIAL

Figure(s):	From:	
12, 15	Sides of stove	4"
12, 15	Back of stove	4"
11	Corner of stove	4"
7, 8	Vent pipe	<u>Per Manufacturer's Instructions</u>
13	Stove to mantel	12"
10	Floor protection: Front (from faceplate)	6"
10	Floor protection: Sides & back of stove	0"
14	Alcove: Vertical to Combustibles	16"
15	Alcove: Sides	4"
15	Alcove: Back	4"

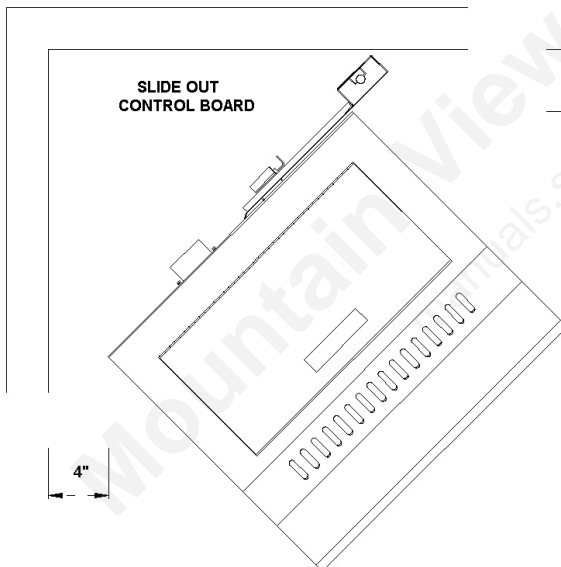

Figure 11 (Top View)  
Clearances: corners of stove

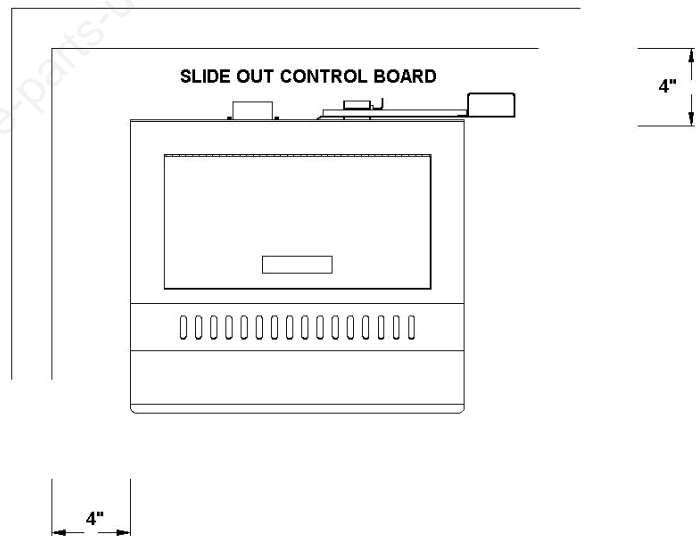
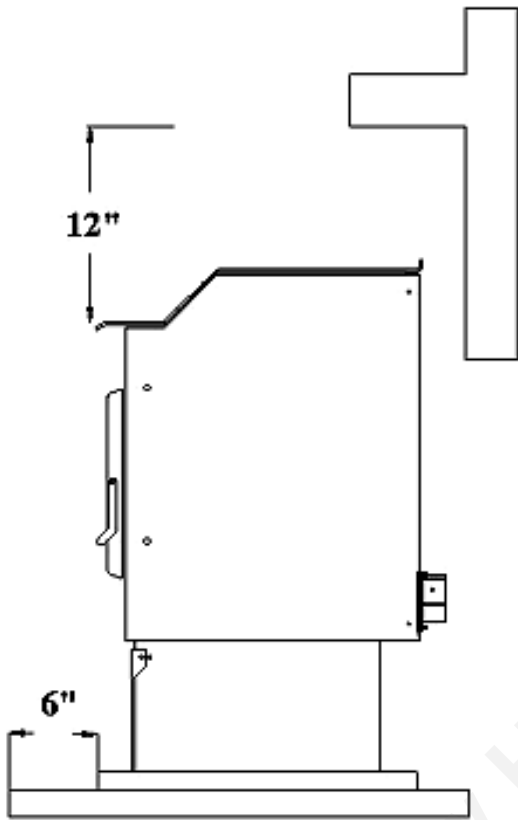
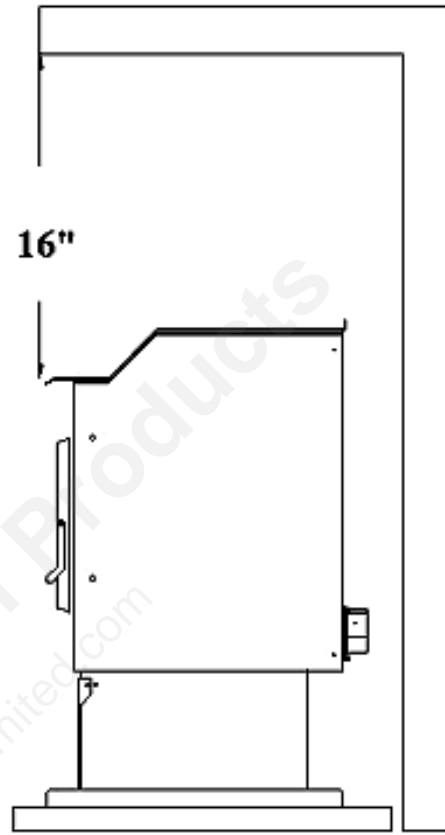

Figure 12 (Top View)  
Clearances Sides and Back



Floor Pad and Mantle Clearances  
Figure 13



Alcove Installation (Side View)  
Figure 14

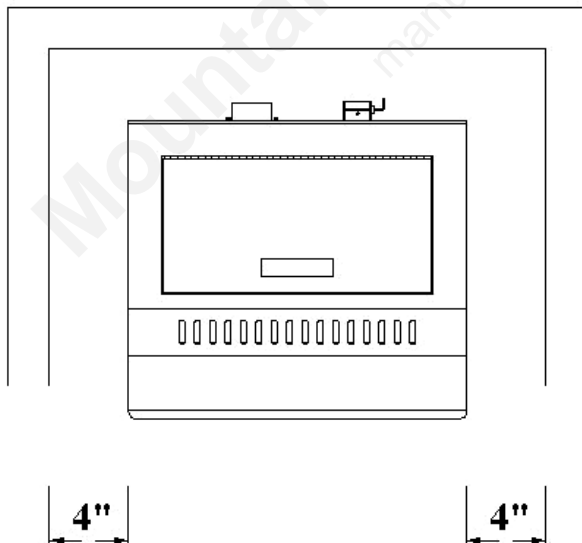

Figure 15  
Alcove Installation (Top View)

4"

**Although 4" is the minimum clearance to the sides of the stove, this is not recommended due to the need for access into the inside of the stove for the maintenance, as spelled out in the Operations Manual. Please read the section covering the Daily Maintenance, Periodic Maintenance and Yearly Maintenance in the Operations Manual.**

## OUTSIDE COMBUSTION AIR

1. Under certain conditions it is recommended that the stove be connected to an outside source of combustion air to improve performance. Flexible metal hose, or rigid metal pipe, (conduit), must be connected around (NOT INSIDE) the combustion air inlet tube. Be careful not to pinch or bend the outside air pipe with too small a radius which may be terminated flush with the outside wall but should be protected from wind and weather by a hood. Note: The outside air pipe must terminate above the maximum snow line. **Optional Outside Air Kit 100354 is available to connect to the intake damper.**

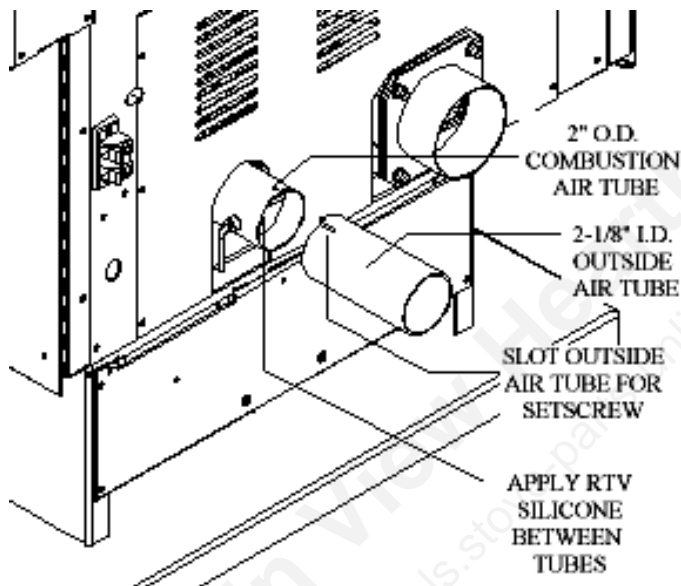

### WARNING

**USE THE AIR INTAKE DAMPER FOR ADJUSTING COMBUSTION INLET AIR ONLY! OTHER METHODS OF RESTRICTING OR BLOCKING COMBUSTION INLET AIR ARE STRICTLY PROHIBITED!**

Figure 16

2. Outside air may be drawn from a semi-enclosed attic or crawl space or any semi-enclosed space. Take care not to draw cold air past water pipes that may freeze.
3. Increase the outside air pipe diameter to 3" for runs over ten (10) feet and elevation over 4,000 feet. Note: Long runs should be avoided.
4. Terminate the outside air pipe below the exhaust vent outlet.
5. An open mesh screen should be placed over the outside air pipe opening to prevent birds or rodents from nesting in the opening. Use an elbow or shield to prevent prevailing winds from blowing directly into the outside air intake pipe. NOTE: Mesh screen should be no smaller than one-fourth inch (1/4") by one-fourth inch (1/4").

**WARNING: OUTSIDE COMBUSTION AIR IS REQUIRED FOR ALL MOBILE HOME INSTALLATIONS!**

# Mobile Home Installation

Unit must be installed in accordance with the:  
**Manufactured Home and Safety Standard (HUD), CFR 3280, Part 24**

**Unit may be installed in a Mobile Home, after the initial sale of the Mobile Home. Not for use in Recreational Vehicles.**

Figure 17

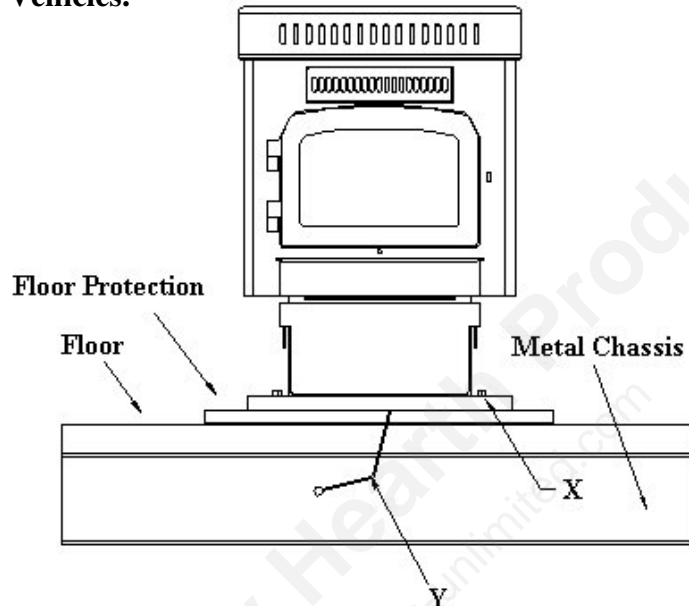

- 1. WARNING: DO NOT INSTALL IN A SLEEPING ROOM.**
- 2. WARNING: COMBUSTION AIR MUST COME FROM THE OUTSIDE OF THE MOBILE HOME! FAILURE TO DO SO MAY CREATE NEGATIVE PRESSURE WITHIN THE MOBILE HOME AND COULD DISRUPT PROPER VENTING AND OPERATION OF THE PELLET STOVE.**
- 3. CAUTION: THE STRUCTURAL INTEGRITY OF THE FLOORS, WALLS, CEILING AND ROOF MUST BE MAINTAINED.**
4. Permanently bolt the stove to the floor, (X).
5. Electrically ground the stove and pedestal to the metal chassis of the home. Use a number eight, (8) gauge or larger copper wire, (Y).
6. Maintain an effective vapor barrier at location where PL vent exits the structure.
7. Check any other local building codes or other codes that may apply.
8. Do not use components other than those specified for use with this unit.
9. Floor protection requirements must be followed precisely.
10. PL Vent must be used for exhaust venting. (Single wall vent is not allowed). Follow PL Vent manufacturer's installation directions and observe all listed clearances to combustibles.

# Prescott EXP and Prescott EXL Operation

**This wood heater needs periodic inspection and repair for proper operation. It is against federal regulations to operate this wood heater in a manner inconsistent with operating instructions in this manual.**

**The Stove is not warranted against damage caused by using poor pellets or other fuels not approved for use in this Stove, incorrect operation, improper maintenance, or incorrect installation.**

**CAUTION:** Operate this unit only with the fuel hopper lid closed. Failure to do so may result in emission of products of combustion from the hopper under certain conditions. Maintain hopper seal in good condition. The auger will be prevented from operating by a hopper lid switch. Close lid immediately after filling hopper with fuel.

This unit requires 120-volt AC power to operate. In the event of a power failure the unit will shut down. **DO NOT ATTEMPT TO RUN THE UNIT DURING A POWER FAILURE.**

**PREVENTING CHIMNEY FIRES** - Chimney fires can be prevented by properly operating the stove and by periodic inspection and cleaning of the chimney. When wood is burned it produces tar and other organic vapors, which combine with expelled moisture to form creosote. The creosote vapors condense in the relatively cool chimney flue associated with a slow burning fire. As a result, creosote residue accumulates on the flue lining. When ignited, this creosote can result in an extremely hot chimney fire.

The chimney and chimney connector should be inspected at least once every two months during the heating season to determine if a creosote build-up has occurred. If a significant layer of creosote has accumulated (3 mm or more) it should be removed to reduce the risk of a chimney fire. Use of an appropriately sized chimney brush or the services of a professional chimney sweep are recommended. Also check to make sure the system is not getting plugged with fly ash. Remove the Fly Ash if needed. Use of an appropriately sized chimney brush or the services of a professional chimney sweep are recommended.

**APPROVED FUEL is PFI Premium Pellets.** Clinkers and Ash are by-products of pellet combustion and are not caused solely by your Stove. Stove performance can be quickly and severely reduced if poor quality fuel is used. Contact your dealer for more information on PFI Premium Pellet fuel.

Do Not Use Chemicals or Fluids to Start The Fire.

**Do Not Burn:** Garbage, Gasoline, Naphtha, Engine Oil, Lawn Clippings, Yard Waste, Rubber, Plastic, Waste Petroleum Products, Paints or Paint Thinners, Asphalt Products, Construction or Demolition Debris, Railroad Ties, Pressure Treated Wood, Plywood, Particle Board, Manure or Animal Remains, Paper Products or Cardboard.

Burning the above materials may result in release of toxic fumes or render the heater ineffective and cause smoke.

The prohibition against burning these materials does not prohibit the use of fire starters made from paper, cardboard, saw dust, wax and similar substances for the purpose of starting a fire in an affected wood heater.

**NOTE:** Pellets with excessive sawdust should be screened by sifting with a 1/4" mesh screen. Store Pellets under cover on a wooden pallet or other methods to ensure they do not become rain soaked or absorb moisture from damp or wet floors. Do not store pellets within Stove installation clearances or within the space required for ash removal.

The Prescott EXP and EXL are approved for use with PFI Premium Pellets. Pellets within this category will present variations that may affect the way your stove burns.

The different characteristics that can affect the stove are:

- 1 – Pellet Length. Shorter pellets will have a higher feed rate than longer pellets. Extremely long pellets may cause a lower feed rate than was established during testing. On the other hand extremely short pellets may cause a higher feed rate than was established during testing. Adjustments can be made to fix the feed problems in the problem occurs. See FAQ section in the back of the manual.
- 2 – The amount of fines will also affect the feed rate by slowing the flow in the hopper and the auger tube. The best solution for this is to screen the pellets to get rid of the fines.
- 3 – Hard wood pellets will feed faster than soft wood pellets due to the natural pitch in soft wood that makes the pellets less slick than hard wood pellets.

**INSTALLATION CHECK** - Proper installation is essential for safety, effective Operation, Warranty Coverage, Insurance requirements and to meet Local Building Codes. Installation Requirements are described in the first section of this manual. Verify the installation is correct before firing up the Stove for the first time.

1. The fans of this Stove may cause a negative pressure area in the room where this Stove is installed.
2. Outside Combustion Air may be needed if:
  - The unit does not vent steadily, smells, experiences smoke rollout, burns poorly, or back-drafts whether or not there is combustion present.
  - Any of the symptoms listed above are alleviated by opening a window slightly on a calm day.
  - The house is sealed with a well-sealed vapor barrier and tight fitting windows and doors and/or has any powered devices, which exhaust house air.
  - There is excessive condensation on the windows during the winter.
  - A ventilation system is installed in the house- Adhere to all Clearances and Restrictions specified in the Installation Instructions of this Stove.

When storing fuel be sure to use sealed containers in a dry environment to prevent the fuel from absorbing moisture and becoming damaged. Do not store bags of pellets directly on concrete.

- Establish a routine for the storage of fuel, care of the Stove and Firing Techniques.
- Check daily for creosote build-up until experience shows how often cleaning is necessary.
- Be aware that the hotter the fire, the less creosote is deposited, and that weekly cleaning may be necessary in mild weather, even though monthly cleaning may be enough in the coldest

months. Run the Stove on the hottest setting once a day for 30 – 45 minutes to prevent excessive build-up in the Stove.

- Have a clearly understood plan to handle a chimney fire. Contact the local fire department for information if needed.
- Keep the doors closed and all seals in good condition while operating the Stove.
- INSPECT THE FLUE PIPES, JOINTS AND SEALS REGULARLY TO ENSURE THAT SMOKE AND FLUE GASES ARE NOT DRAWN INTO, AND CIRCULATED BY THE AIR-CIRCULATION SYSTEM.
- CLEANING OF THE HEAT EXCHANGER, FLUE PIPE, CHIMNEY AND DRAFT INDUCER IS ESPECIALLY IMPORTANT AT THE END OF THE HEATING SEASON TO MINIMIZE CORROSION DURING THE SUMMER MONTHS CAUSED BY ACCUMULATED ASH.
- The Stove will not operate during a power failure. Prolonged Power Outages will require the use of a generator to operate the Stove.

## Control Board Features

The Control Board controls all functions of the Prescott EXP and EXL by monitoring sensors that are in the system. These sensors serve 2 purposes.

- General Operation of the stove.
- Safety Features, to shut the unit down in the event the sensors detect a problem in the unit.

The Control Board also has Diagnostic Capabilities to help in diagnosing 3 areas in the stove. These areas are:

- High Temperature Limit.
- Proof of Fire Sensor
- Vacuum in the Firebox

A closer look at the Control Board to the right in figure 18 will explain how the board works.

The ON/OFF button, The Auger Feed Button (used to prime the Pot with Fuel) and the **Heat Level** and **Draft Trim** Buttons. The last 2 buttons have High and Low buttons to advance/adjust these settings up or down. There is a slide switch that controls the Thermostat Mode and an LED Light bar that indicates which of the 5 Heat Settings the Stove is running on.

*The LED Light bar is also used during the Diagnostic process, see page 34 for more details*

- The Heat Level button will advance the setting up and down between level 1 and 5. It will also be used in the Fine Tuning process of the feed rates if needed.

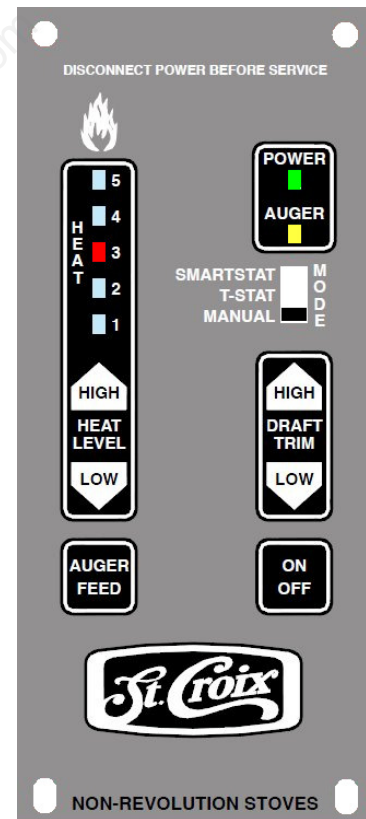

Figure 18

2. The Auger Feed button will allow the user to manually auger fuel into the burn pot on start up when needed. This is particularly helpful in priming the Auger Tube when it is empty (After the hopper has run out of pellets). **Do not tamper with the Auger Feed button to override the automated feed system. This may cause the unit to Overheat.**

➤ To adjust the Feed-rates:

Hold the Auger Feed Button down and press the Heat Level High/Low button and this will change the ON Time up or down .25 seconds from the factory setting. Watch the LED lights to see the setting is on (it will flash the new setting). This new setting will stay in memory from this point on.

3. The On/Off button not only turns the Stove On and Off, it also resets the board if one of the sensors has detected a problem and the board is flashing a Diagnostic code.

4. The Draft Trim button allows for adjusting the Exhaust (Combustion) fan voltages up or down providing for fine-tuning of the combustion air. The LED light bar indicates the level of adjustment and the factory setting is the center LED light. This allows for 2 adjustments up and 2 adjustments down. (See point 9 on page 45)

➤ To adjust the Combustion Fan voltages: Hold the Auger Feed button down and press the Draft Trim High/Low button and this will change the fan voltage approximately 2.5 volts up or down from the factory setting. Watch the LED lights to see the setting is on (it will flash the new setting). This new setting will stay in memory from this point on.

5. The Thermostat Slide switch allows the stove to be run in 3 different Modes:

a. **Manual Mode.** The Control Board controls all functions of the Prescott EXP and EXL.

b. **T-Stat Mode.** *The Stove is Fully-Automatic in the T-Stat Mode. (T-Stat requires the stove be turned on at the control board the first time).* The unit is hooked to a Thermostat and when calling for heat the unit will advance to the Heat level set at the Control board. Once the Heat demand has been met, the Stove will immediately shut down. Use this setting when heating a small area or when Temperatures are Moderate.

c. **SmartStat Mode.** The unit is hooked to a Thermostat and when calling for heat the stove will advance to the Heat level set at the Control board. Once the Heat demand has been met the stove will drop to the #1 Heat Level setting **and pilot for one hour**. If the Thermostat does not call for heat during that hour the unit shuts off and **re-lights itself the next time the Thermostat calls for heat**. This setting is best used during early Fall or late Spring, when constant heat is not needed.

6. **Cleaning Cycle.** The Prescott EXP and EXL only use Programs 3 & 4. These 2 programs have a Cleaning Cycle built into them that allows the unit to drop to the #1 level for 5 minutes on timed intervals. During the cleaning cycle the Combustion Fan will run at line voltage to blow excess ash from the burn pot. **The ON/OFF light blinks (slowly) and the control board is locked out during this cycle.**

**Pre-Lighting Instructions:** The Control Board has 4 separate programs. Two of the programs are for the Auburn (Programs 1 & 2) and two of the programs are for the Prescott EXP

and EXL (Programs 3 & 4). Before lighting the stove for the first time, ask your dealer about how to change the program or read the instructions on the following page. The unit is set to the default program, which is program 3. There is no feature to check to see which program is running. You must change program to see which program was running. Then you cycle back through the programs to the appropriate program.

The Cycle time is the total of the ON Time & OFF Time added together. The ON Times are constant, so this means that the OFF Time is increased or decreased, depending on the program chosen.

**Program 1.** The Cycle Time is 11.5 seconds. This program is only to be used with the Auburn model. **(DO NOT USE THIS PROGRAM WITH THE PRESCOTT SERIES).**

**Program 2.** The Cycle Time is 13 seconds. This program is only to be used with the Auburn model. **(DO NOT USE THIS PROGRAM WITH THE PRESCOTT SERIES).**

**Program 3.** The Cycle Time is 11.5 seconds. This Program offers Self-Ignition and is only for units that have the Versa Grate system & Igniter installed. This program is the default program for use with the Prescott EXP and EXL and is for use with PFI Premium Pellets. **(DO NOT USE THIS PROGRAM WITH THE AUBURN).**

**Program 4.** The Cycle Time is 10 seconds. This Program offers Self-Ignition and is only for units that have the Versa Grate system & Igniter installed and is for use with PFI Premium Pellets. **(DO NOT USE THIS PROGRAM WITH THE AUBURN).**

Program 4 is for adjusting for variations that occur with PFI Premium Pellets. Ask your dealer before using this Program in your unit. See page 25 for more information on variations between different brands of pellets.

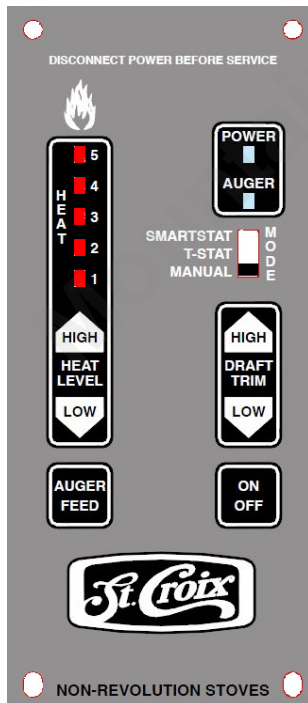

Figure 19

### Changing the program on the Control Board

To change the Program the stove must be in the OFF position, the unit must be completely cooled down so the Proof of Fire Switch is Open and the Thermostat slide switch must be in the Manual mode. (See figure 19)

**Press & hold** the Auger Feed Button, then press the Trim **High & Low** Button at the same time. The LED lights that indicate the heat level will flash. The number of times the lights Flash will indicate which program is running.

**Program 1 – LED lights flash *once***

**Program 2 – LED lights flash *twice***

**Program 3 –LED lights flash *three times***

**Program 4 – LED lights flash *four times***

## Lighting Your Stove

### **WARNING: - Risk of Fire.**

- Do not operate with the Firebox door or Ash Removal doors open
- Do not store Fuel or other Combustible material within marked Installation Clearances.
- Inspect and Clean Flues and Chimneys regularly.

**Danger: Risk of Fire or Explosion - Do not burn Garbage, Gasoline, Drain Oil or other Flammable Liquids.**

**WARNING: Do not bypass the hopper lid switch. The auger can start at any time while the Stove is running, this is a high torque motor that is capable of doing SERIOUS harm to fingers. Keep fingers and other objects away from the auger.**

When lighting your Stove for the first time the auger tube will be empty, it helps to hold the Auger Button in until you hear fuel drop into the burn pot.

1. Make sure there are pellets in the hopper and the viewing door and ash pan door are closed.
2. Push the On/Off button on the control board. (See figure 18 on page 26)

At this point all that needs to be done is to monitor the burn pot to make sure the stove starts up properly. Once the On/Off button has been pushed the Ignition Cycle takes over.

The Ignition Cycle works as follows:

- a. The Combustion fan and Room fan come on at high speed and the control board checks to make sure the Vacuum switch locks in. (See Diagnostic features on page 34 and 35)
- b. If the board senses the Vacuum switch the Combustion fan drops to the #1 setting and the Room fan shuts off.
- c. The Igniter and the Auger come on and feed for 1.5 minutes continuously and then switches to the #1 feed setting for the remainder of the ignition cycle.
- d. The stove will typically light in the first 3 - 4 minutes. After 5 minutes the board checks for "Proof of Fire". Once the board senses P.O.F. the Igniter shuts off and the stove has started successfully and the unit will enter "Normal Operation Mode".

If the board still fails to sense the Proof of Fire switch the Stove will go into "Safety Shutdown" and Flash the #3 LED. (See section on Diagnostic Features on page 34.) If this happens, repeat the Start-Up process. **CAUTION: NEVER ADD FIRE STARTER TO A HOT STOVE.**

## Shutting the Unit Off

1. Press the On/Off switch once; the lights will go off and the fire will go out in a few minutes. The board essentially goes into "Safety shutdown".

2. As long as the temperature within the stove remains above 110°F the Fans will continue to run. When the P.O.F. switch drops out, the room fan shuts off and the Combustion fan will run for another 10 minutes and finally shut down completely.

**NEVER unplug the Stove to shut it off. Doing so may cause smoke to enter the room**

## Importance of Proper Draft

Do not neglect to adjust the Combustion Air Damper during the break in period of your new Stove (See Figure 20). Your Stove is equipped with an air inlet damper. The purpose of this damper is to adjust combustion airflow to match the characteristic of each specific air inlet and chimney configuration. See figure 20 for initial damper settings for pellets. The damper will most likely only need a small adjustment during the break-in period. Break-in requires the burning 15 bags of pellets or a continuous burn for two weeks.

If you notice a difference in the operation of the Stove, **first check to see if there has been a change in the fuel you are burning**. If the fuel properties have significantly changed, such as the fuel is very dirty, then making a change to the damper is correct.

**However if the Stove needs cleaning, changing the Damper may mask the fact that the stove is getting plugged.** It is always a good idea to thoroughly clean your stove before making a significant damper change.

**If you experience problems adjusting the Stove during the Break-In Period, contact your dealer.** Some chimney systems will fall outside the norm, for example, a chimney with excessive draft or one with a long horizontal run.

## Initial damper settings for a stove using a Horizontal Vent system

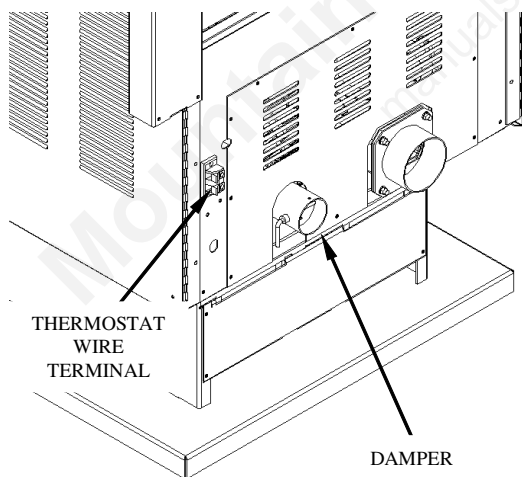

Figure 20

First note the location of the set screw. This screw is turned in until it stops against the tube. Moving the screw is normally not needed.

- Heat level 1: Open the damper 1/8 of an inch.
- Heat level 2: Open damper to 3/16 of an inch.
- Heat level 3: Open damper to 3/16 of an inch.
- Heat level 4: Open damper to 1/4 of an inch.
- Heat level 5: Open damper to 5/16 of an inch.

Observe the flame and adjust the damper from these positions if needed based on “Flame Pattern Characteristics listed on the next page. Adjust the damper 1/16 of an inch at a time and wait 5 minutes between adjustments to allow the pot to balance out.

Stoves connected to **Vertical Vent** systems should use reduced damper settings. Close the damper a 1/16” – 1/8” to compensate for the natural draft of the vertical chimney.

## **Adjusting the damper during the break in period when burning Pellets:**

Start with the stove running in the pilot mode (#1 heat level) first. A proper burn while burning on Level 1 will prevent creosote formation in the venting system. Running the stove with too much air on the low burns will cause smoke and low Burn Pot temperatures. This can lead to Creosote formation. Once you have adjusted the damper for the best burn, make note of the setting. Now advance the stove one heat level at a time and adjust the damper if needed, making note of the proper setting for future reference.

**Conditions indicating excessive Draft:** If a black shiny build-up (difficult to wipe off) is noticed on the glass and inner surfaces, after the Stove runs on the low (pilot) setting for an extended period of time, the damper must be closed some. Close the damper 1/16 of an inch at a time until the build-up starts to wipe off easier. Some build up on the glass is normal and should be removed during daily maintenance

**Conditions indicating inadequate Draft:** If black soot (wipes off easily) builds up on the glass and black smoke is visible at the tips of the flames start to open the damper 1/16” at a time. Wait 5 – 10 minutes before attempting another adjustment. An occasional wisp of black smoke is normal every now and then.

Occasionally check for the formation of creosote in the unit and venting system during the season. Constantly running the Stove on a low setting with too much combustion air may cause creosote to form. Burn pot temperatures can be “too cool” when burning on low with too much draft.

Additional draft adjustments can be made using the Draft trim feature built into the control board. Read point 4 on page 27 and read the “Frequently Asked Questions” in the back of the manual.

### **Flame Pattern Characteristics**

**Correct Flame Pattern** - Bright yellowish-white flame with a brisk movement, having sharp pointed end tips extending up towards the Heat Exchange Tubes while forming a fan-like shape. Small amounts of ash and some live sparks being blown out from the Burn Pot area is considered normal operation.

**Incorrect Flame Pattern** - Dark Orangish-Brown flame with a lazy movement, having black smoky end tips curling up and over the Heat Exchange Tubes while forming a fireball-like shape. Some Ash or Live Sparks not being blown out from the Burn Pot area is considered abnormal operation. Excessive black soot forming on the ceramic glass surface is a sign of very poor combustion (not enough combustion air) and should not be overlooked.

At the other end of the spectrum; an extremely brisk flame which blows large pieces of live coal out from the Burn Pot area and causes stubborn shiny black build-up on the glass (too much combustion air) is also considered undesirable and requires the damper to be closed.

**If you experience problems adjusting the stove during the Break-In Period, contact your dealer.**

## USE OF A THERMOSTAT

The Prescott EXP or Prescott EXL offer the optional feature of thermostatically controlling your new stove. By using a thermostat to control the operation of your Stove you can benefit two ways. First of all, after setting the thermostat to your desired heating needs, the stove will operate accordingly to uniformly maintain your desired temperature setting. Secondly, the fuel consumption is being optimized, which ultimately results in lowering your seasonal heating costs.

While the room temperature remains cooler than your desired thermostat setting, the stove will operate at any of the 5 HEAT ADJUST selector positions. Read the Operations manual to determine which Thermostat Mode you want to use. You can choose between the T-Stat Mode and the SmartStat Mode.

1. Once you have successfully lit your stove, set the thermostat to your desired heating needs.
2. Set the HEAT ADJUST selector to a position that will effectively create a rise in room temperature above your thermostat setting. The recommended heat settings while using a thermostat are any position between 2 through 5.

### Thermostat Hook-up

Connect the wires from the thermostat to the external wire terminal on the back of the stove (see figure 21 on the following page).

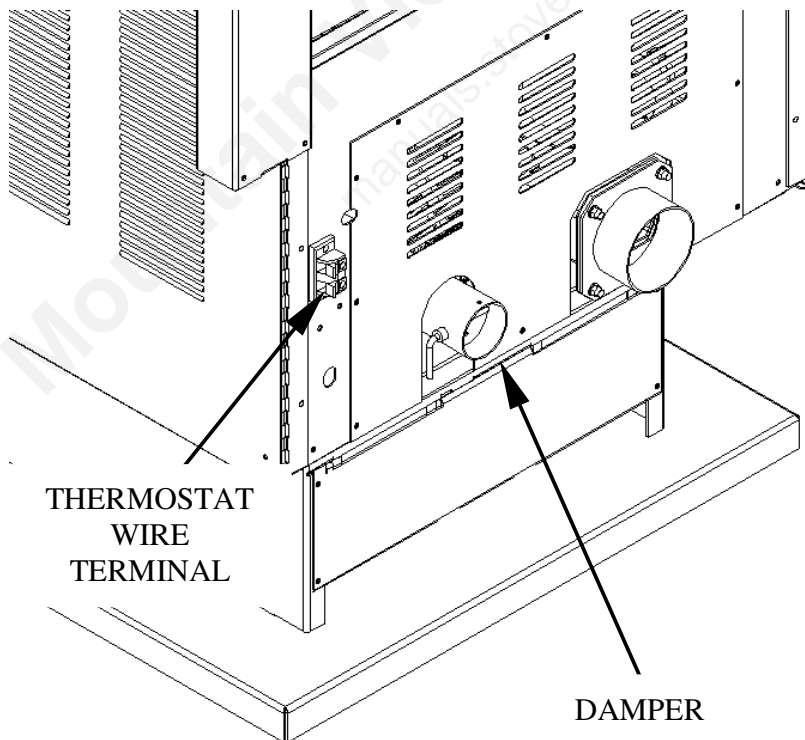
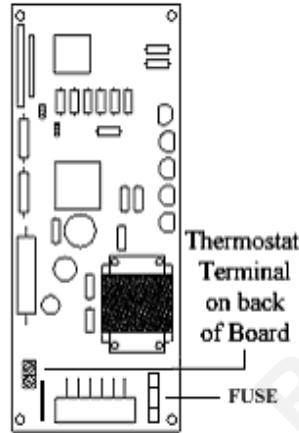

Figure 21

The external Thermostat wire terminal has been pre-wired to the thermostat wire Terminal on the back of the control board (See figure 22)

Read Frequently Asked Questions section in the Operations Manual to Troubleshoot the Thermostat.

Figure 22



**NOTE: Installers must determine a neutral location of where to mount the thermostat for accurate room temperature measurements.**

## Thermostat Control & Pilot Settings

The Stove may be controlled with a thermostat to help maintain a more constant temperature. The Stove will react a little slower to a thermostat compared to a Gas or Electric Stove. With this in mind the low setting can be adjusted to increase or decrease the amount of fuel used. This will allow the heat output during the pilot stage to be matched to the size of the home. A larger home will require more heat than a small one. Keep in mind that the Stove is constantly producing some heat that helps heat the home while it is in pilot mode. If the home seems too warm, and the Thermostat is never calling for heat, a lower pilot setting may be a better fit for the home. *(Read point 2 on page 27 for adjusting the feedrates on the low setting). Running the unit in the T-Stat mode will also allow the unit to shut down once the Heat Demand has been met.*

**Remember: Choosing a lower Pilot setting may require the Draft Fan Voltage or the Damper to be fine-tuned to match the lower feed rate. Monitor how the Stove is operating after a change is made and adjust the damper or Combustion Fan voltage accordingly.**

## Diagnostic Features of the Control Board

The #2 LED, #3 LED and #4 LED lights on the LED Light bar) will flash to give a diagnostic code to help in diagnosing problems that may occur. *(Read Frequently Asked Questions for more information)*

These conditions fall into 2 categories:

- a. Heat related issues.
- b. Vacuum related issues.

The Diagnostic Lights flash as follows:

1. The **Proof of Fire** switch. This switch will sense the temperature of the Exhaust rising during start up. If the Exhaust temperature does not reach 110 degrees F, or if, during use, the temperature drops below 110 degrees F, the stove will go into “**Internal Alarm**” and the Auger will quit feeding fuel. Once the Stove completes the safety shutdown, the #3 LED will start blinking. *(Read Frequently Asked Questions for more information)*
2. The **High Limit** switch. This sensor will sense if the unit reaches temperatures that are too high for normal operation. If this happens the Auger will quit feeding and the #4 LED light will start blinking. *(Read Frequently Asked Questions for more information)*
3. The **Vacuum** switch. For the Stove to operate correctly the firebox needs to be sealed. During the first 30 seconds after the unit has been turned on, the control board will check to see if the switch senses negative pressure (Vacuum) in the firebox of the Stove. If there is no negative pressure, the Stove will go into “Safety shutdown” and the #2 LED will start blinking. *(Read Frequently Asked Questions for more information)*

During “Normal Operation” a 60 second delay has been incorporated before the unit shuts down when the board senses loss of vacuum. This is to accommodate opening the doors during maintenance. Once the board senses loss of vacuum the ON/OFF light will start blinking. While the light is blinking the control board will not feed any fuel nor respond to any of the buttons. Once Vacuum has been restored the unit will revert to normal operation.

**Unresponsive Control Board** - When the control board becomes unresponsive, the control board may be in Internal Alarm. The control board has sensed one of the Safety sensors. This may cause the unit to go out and flash a Diagnostic Code. In some cases, after waiting approximately 45 seconds the Stove will start responding to the control board again. Many times, the cause of this is a change in the vacuum inside the firebox. This may be caused by excessive wind or by opening the Firebox door. The control board will monitor the vacuum switch and resume normal operation if the vacuum returns to normal.

**Caution: See Cleaning Cycle on page 28. The control board is locked out during the cleaning cycle and may appear to be unresponsive. Simply wait until the cycle is complete (Once the power light quits blinking) and the board responds again.**

## Safety Features

1. “**High Limit**” switch”, an overheat safety switch will shut off the fuel feed if the Stove reaches temperatures above normal operating temperature. This is a “Normally Closed” switch. If the High limit switch trips several times, the problem in the Stove *must* be diagnosed before the unit is put back into service, (Defective Room Fan, dirty Room Fan, defective High Limit switch or possibly a bad Control Board)
2. **Vacuum switch** also called the **Negative pressure switch**. When the Stove is turned on the Exhaust fan will create a negative pressure in the firebox. The control board continually checks to see if Negative Pressure (vacuum) is present during operation of the Stove. If the exhaust venting system becomes clogged or obstructed, the firebox door is left open or the exhaust fan quits working the control board will go into “Safety shutdown”.

There is a 60 second delay before the unit shuts down to allow for cleaning the glass before then Vacuum switch shuts the stove down. This is sufficient for the Daily Maintenance

3. **Proof of Fire switch** also called the **P.O.F.** This senses the temperature rise in the exhaust system. The switch is “Normally Open” and closes the circuit at 110 degrees. The Stove will shut down if temperatures above 110 degrees F are not sensed during start up or if the temperature drops below 110 degrees during normal operation.
4. **Hopper Lid Switch.** The hopper lid switch will shut off the auger motor when the hopper lid is open. Be sure the lid closes completely when refilling the hopper or the unit will shut down

**WARNING:** The Insert has been Safety Tested by an accredited, independent laboratory. These safety features are designed to protect life and property. Bypassing these features voids all warranties and the safety listing of the Prescott EXP and EXL.

## Prescott EXP and EXL Maintenance

**NOTE: WHEN YOU FIRST OPERATE THE STOVE, CHECK TO DETERMINE THE FREQUENCY OF CLEANING. THE STOVE REQUIRES A MINIMUM AMOUNT OF DAILY MAINTENANCE. REQUIRED MAINTENANCE DEPENDS LARGELY UPON THE QUALITY OF FUEL BURNED AND THE RATE OF BURN. THE AMOUNT OF DAILY MAINTENANCE WILL INCREASE IF FUEL QUALITY DECREASES AND/OR THE BURNING RATE OF THE FUEL INCREASES.**

**NOTE: FAILURE TO KEEP YOUR STOVE CLEAN, AS DESCRIBED IN THIS MANUAL, COULD RESULT IN POOR OPERATION, INEFFICIENT FUEL USAGE AND A POSSIBLE SAFETY HAZARD! IT IS THE RESPONSIBILITY OF THE OWNER/USER TO DETERMINE THE NEEDED MAINTENANCE FREQUENCY.**

**CAUTION: THE DOOR AND FRONT PART OF THE STOVE WILL BE HOT. DO NOT TOUCH ANY PART OF THE UNIT THAT IS HOT!**

**NOTE: FAILURE TO KEEP YOUR STOVE CLEAN, AS DESCRIBED IN THIS MANUAL, COULD RESULT IN POOR OPERATION, INEFFICIENT FUEL USAGE AND A POSSIBLE SAFETY HAZARD! IT IS YOUR RESPONSIBILITY TO DETERMINE THE MAINTENANCE FREQUENCY.**

**MAINTAINING THE STOVE** - The stove requires a minimum amount of daily maintenance. Required maintenance depends largely upon the quality of pellet fuel burned and the rate of burn. The amount of daily maintenance will increase if fuel quality decreases and/or the burning rate of pellets increases.

# The Versa Grate System.

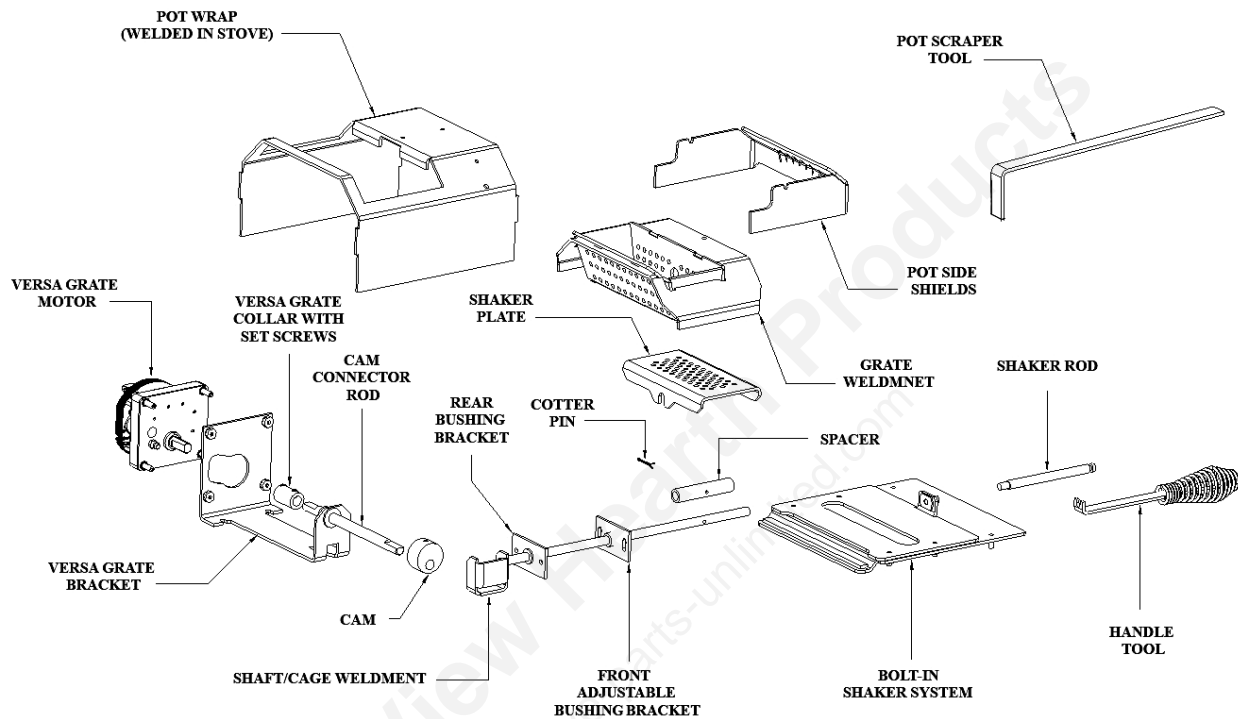

Figure 23

This feature allows the stove to operate for longer periods of time without the grate requiring cleaning. If the flame becomes dark orange, is accompanied by black smoke or burns with a lazy motion - it's time to clean the grate. Frequency of cleaning depends on the amount of fuel being burnt and the quality of the Fuel. Poor quality fuel will require more frequent cleaning of the Versa Grate System shown in figure 23.

First, let's become familiar with the burn system in a St. Croix Pellet stove. Remember, cleaning frequency may change dramatically from one fuel to another. Pellets with high ash content or that have increased amounts of impurities or high moisture content. The St. Croix Versa Grate system is a 2-piece burnpot design. The top Part is called the "Grate Weldment". This sits on top of the "Shaker Plate". This in turn sits on top of the "Shaft/Cage Weldment" which is held in place with the "Spacer" & "Self Locking Twist pin". The Shaft/Cage Weldment is moved towards the front of the stove and then towards the back of the stove by the "Cam" which is connected to the "Versa Grate Motor". This motion is constant while the stove is in operation. The only parts that may need to be removed for cleaning purposes during the Daily or Periodic Maintenance are the "Grate Weldment" and the "Shaker Plate". This is to check the holes in the burnpot system to see if they are plugged.

## Daily Maintenance – Prescott EXP and EXL models.

**CAUTION: THE DOOR AND FRONT PART OF THE STOVE WILL BE HOT. DO NOT TOUCH ANY PART OF THE STOVE THAT IS HOT! CAUTION: NEVER ADD FIRE STARTER TO A HOT STOVE.**

1. Check Grate Weldment and Shaker Plate (See figure 25) to determine if holes are plugged. Clean as needed. With proper precautions the grate may be partially cleaned while the stove is hot. Follow these steps:

- a. Wear a leather glove that covers the lower arm.
- b. Turn the Stove to Heat Level 1 and allow the flame to burn down to a low burn.
- c. Open the firebox door slowly to prevent drawing ash or odors into the room.
- d. Use the “Pot Scraper tool” provided to move the burning pellets to one side of the grate, leaving the ash in the bottom of the grate. (See Figure 23)
- e. Rake the ash & clinkers out over the grate into the ash pan.
- f. Rake the burning pellets across the bottom of the grate.
- g. Close the door and re-select the desired heat setting.

Figure 24

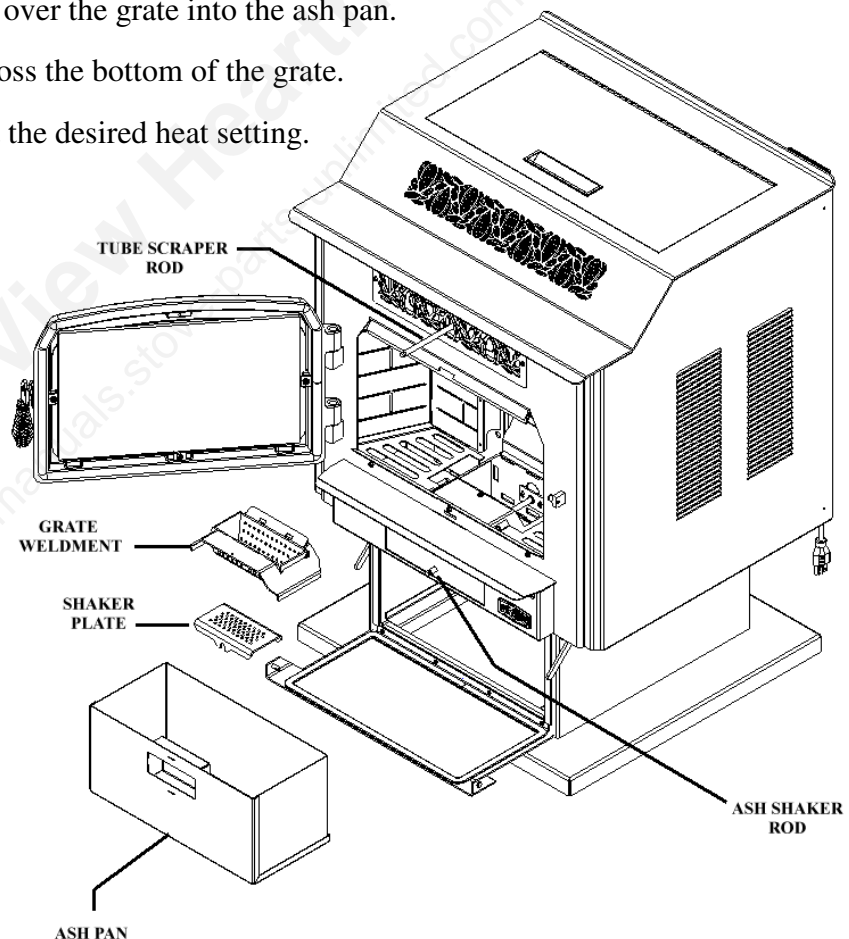

The “Grate Weldment” and the “Shaker Plate” may need to be removed for cleaning purposes during the Daily or Periodic Maintenance if the holes become plugged. This allows a closer inspection of the holes in the pot. Use a 3/16” drill bit to clean out the holes if needed.

2. Once a day pull the Ash Shaker Rod (*See figure 24*) several times back and forth to shake the ashes down into the Ash Pan. Failure to regularly shake the ashes down will cause the stove to start burning dirty.
3. Check ash pan (*See Figure 24*) to determine emptying frequency needed. NOTE: Do not use a vacuum cleaner for this purpose. Hot coals may cause your vacuum filter to catch fire. Place ashes in a metal container with a tight fitting lid. The closed container of ashes should be placed on a noncombustible floor or on the ground, well away from all combustible materials, pending final disposal. If the ashes are disposed of by burial in soil or otherwise locally dispersed, they should be retained in the closed container for at least two days until all cinders have thoroughly cooled.
4. Once or twice daily pull the Heat Exchange Tube Scraper, (*See Figure 24*) out and back in to clean heat exchange tubes. Failure to operate the tube scraper daily may result in poor combustion and loss of heat output. This should be done when the stove is cool or operating on the low temperature setting. Use the Rod Pull Tool that comes with the stove to pull the Tube Scraper Rod.
5. The rate of burn and the quality of fuel will determine how often the window needs cleaning. Prolonged burning at a low burn rate will result in the need for more frequent window cleaning. Burning poor fuel also increases the need to clean the window. Cooling the stove and wiping the window daily with a cloth or paper towel will normally keep the window from accumulating difficult to clean residue. Use of a glass cleaner ONLY permitted when the stove is cold. *Tip: Dip the damp towel in the ashes to remove stubborn buildup on the glass.*

**CAUTION: Do not slam the door. Do not operate the stove with a broken or cracked glass. Replace only with heat resistant ceramic glass supplied by the manufacturer.**

6. **Burn the stove at the HI fuel setting for at least 60 minutes each day.** This helps keep the window, firebrick and firebox and Exhaust area clean. A daily high burn also aids in maintaining the overall efficiency and performance of the stove.

## Periodic Maintenance

**CAUTION:** Periodic maintenance should only be done while the Stove is shut off and cold.

1. **Ashpan.** Empty the ash pan when it appears full (approximately once a week). The frequency of cleaning the ash pan will depend on the quality and amount of fuel being used. Carefully check to make sure the ash pan door is tightly closed after each opening.
2. **Grate Weldment and Shaker Plate.** Clean Grate Weldment and Shaker Plate holes whenever needed. Remove the Burnpot and use a small metal object (Nail, Drill Bit, etc) to clean out plugged holes. (*See Figure 24*). The Grate Weldment and Shaker Plate holes can also be cleaned without removing them by using a small steel brush to clean the holes.
3. Pull the Ash Shaker Rod (*See figure 24*) several times back and forth to shake the ashes down into the Ash Pan.
4. **Clean-Out Ports.** The Prescott models have 2 Exhaust Cleanout Ports located in the LEFT AND RIGHT lower corners of the firebox. (*See figure 25*) Remove covers and clean regularly.

There is an additional Cleanout behind the Ashpan. (See figure 25) This cleanout gives access to the transition area behind the back wall all the way back to below the Combustion Fan. If the stove seems plugged this area needs cleaning.

Frequency of cleaning depends on the amount of fuel being burnt and the quality of the Fuel. **Failure to clean the ash traps will cause the Stove to become plugged with Fly Ash.**

Figure 25

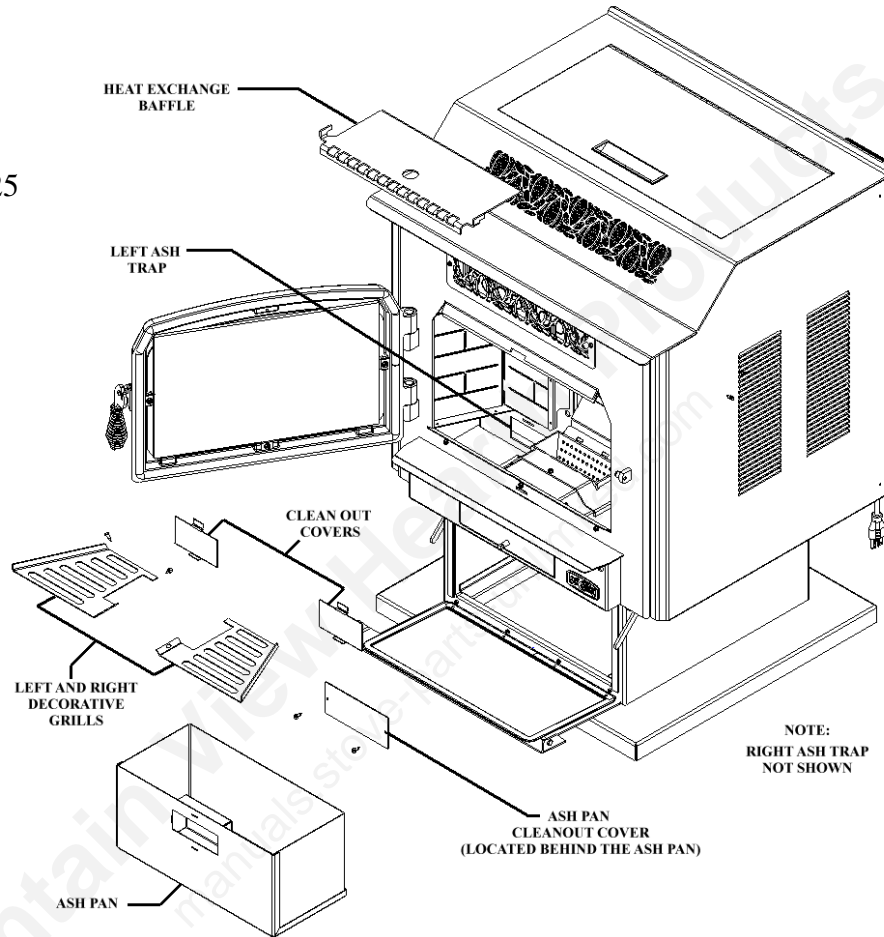

5. **Heat Exchange Baffle.** Remove the baffle and clean the ashes that accumulate on a regular basis. Once a month or sooner, depending on the quality of fuel being used. To remove the baffle (See Figure 25), lift the back of the baffle up to clear the inner back of the stove and slide towards the front of the stove. The baffle will slide out of the keyhole slots and drop down. **When putting the baffle back in the stove, make sure the tabs are in the keyhole slots and the back of the baffle is lifted up over the inner back.**

**Failure to clean the baffle can cause the Stove to become plugged with fly ash.** Frequency of cleaning depends on amount of fuel being burnt and the quality of the fuel. Fuel with low ash content is recommended.

6. **Exhaust System.** See Figure 24 and 25 for information on cleaning fly ash that collects in the vent system. Periodic cleaning of the exhaust system is required. Under certain conditions chimneys may plug up rapidly. Dirty poor quality Fuel and poor installations require more

frequent chimney cleanings. The products of combustion will also contain small particles of fly ash. The fly ash will collect in the exhaust vent and restrict the flow of the flue gases. Judge the frequency of cleaning by checking the amount of ash that accumulates in the Cleanout Tee on the back of the stove. Ask the dealer for suggested frequency of cleaning, equipment needed and procedures for cleaning. Check the Vent Cap at least once every two months during the heating season to see if it has become plugged. **See Page 26 “Preventing Chimney Fires”.**

7. **Gaskets.** Periodically inspect the condition of the rope gasket around the door, window and ash door. Replace as needed.

## Yearly Maintenance

Many dealers offer a Service Contract that will cover Yearly Maintenance. Contact your St. Croix Dealer for assistance in maintaining your Stove in top condition. Yearly maintenance is designed to assure safe operation, prolong the life of the Stove and help preserve its aesthetic appeal.

**NOTE: UNPLUG THE STOVE.** Open the Left and Right side panels of the Stove to gain access to components in the back of the stove. Carefully clean or vacuum any dust, cobwebs and household dust. Carefully vacuum around the fan motors. If electrical wires become disconnected call your dealer for service.

1. **Spring Shutdown.** After the last burn in the spring let the unit cool down. Remove all fuel from the hopper and the auger. Thoroughly clean the burn pot, burn pot box, ash pan and ash traps behind the ash pan. (To locate the ash traps see figure 25)
2. The exhaust system should be thoroughly cleaned at least annually. Call your dealer for this service. (See figure 26 on the following page)
3. The motor/fan area behind the firebox and under the hopper should be vacuumed annually. (See figure 26 on the following page)
4. The exhaust fan should be removed and cleaned with compressed air annually. Call dealer for this service. Annual oiling of the motors is not needed. (See figure 26 on the following page)
5. The Convection fans should be removed and cleaned with compressed air annually. (See figure 26 on the following page)
6. Replace the Door Gaskets if needed.
7. Replace the Ash Pan Door gaskets if needed.
8. Replace the Hopper Lid Gaskets if needed.

**Fall Startup.** Prior to lighting the first fire check the outside area around the exhaust and air intake systems for obstructions. Try all controls to see that they are working prior to lighting a fire.

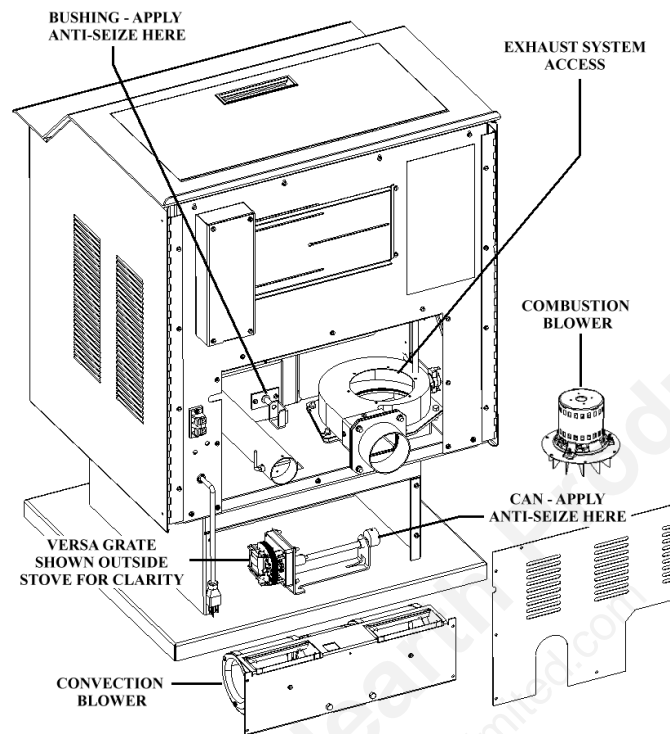
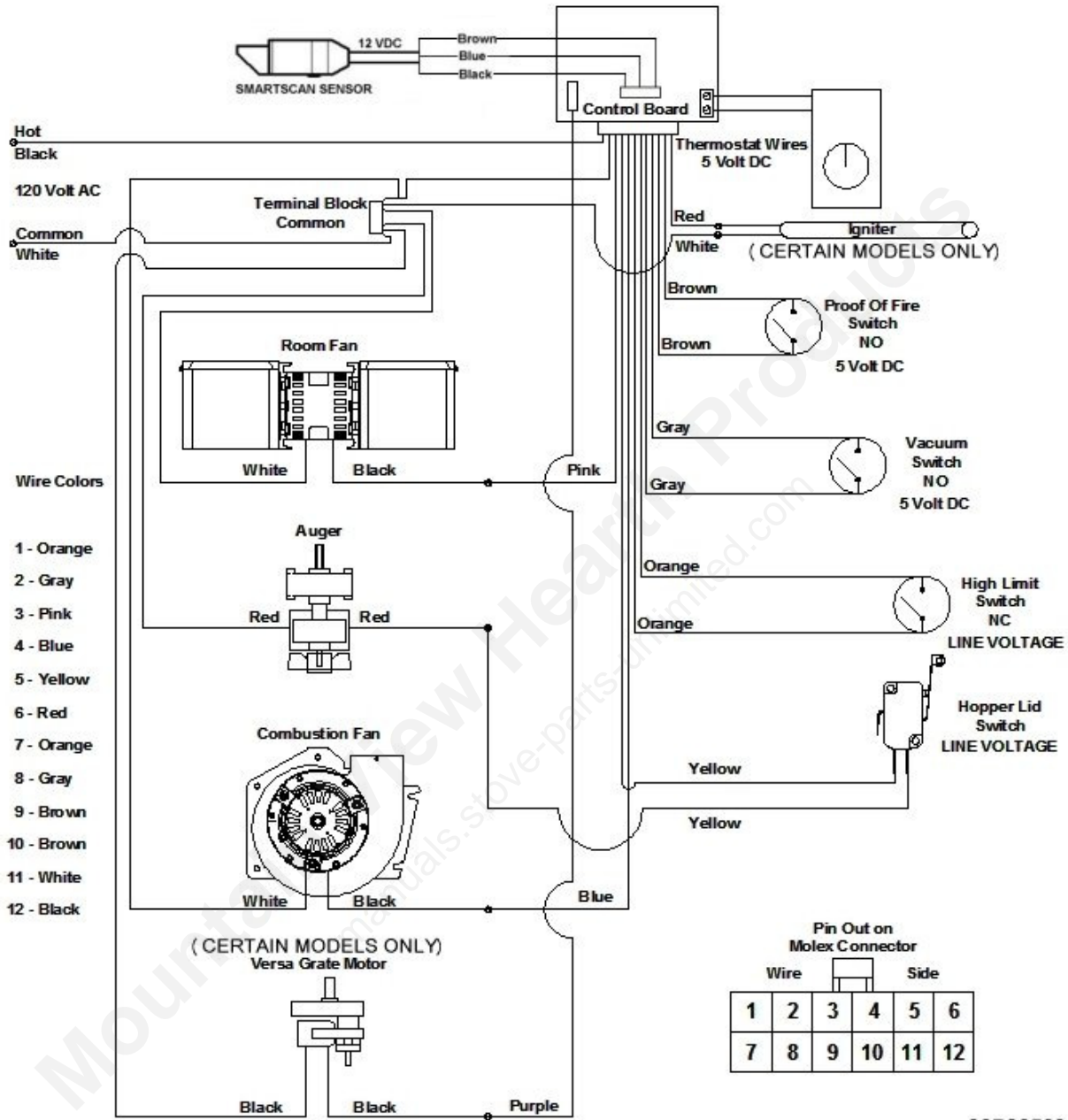

Figure 26

### SAFE OPERATION

1. **Disposal of Ashes.** Ashes should be placed in a metal container with a tight fitting lid. The closed container of ashes should be placed on a non-combustible floor or on the ground, well away from all combustible materials, pending final disposal. If the ashes are disposed of by burial in soil or otherwise locally dispersed, they should be retained in the container until all cinders have thoroughly cooled.
2. **Never use Gasoline,** gasoline type lantern fluid. Kerosene, charcoal lighter fluid or similar liquids to start or “freshen up” a fire in this heater. Keep all such liquids well away from the heater while it is in use.
3. **Creosote, Soot and Fly Ash: Formation and the need for Removal.** The products of combustion will contain small particles of Fly Ash. The fly ash will collect in the venting system and restrict the flow of flue gases. Incomplete combustion, such as occurs during start-up and shut-down, or incorrect operation of the room heater will lead to some soot or creosote formation which will collect in the venting system. The exhaust system should be inspected regularly during the heating season to determine if creosote buildup has occurred. Check more frequently at first to determine a schedule for cleaning the venting system based on individual use of this Stove. If creosote has accumulated, it should be removed to reduce the risk of a chimney fire.
4. **Do not Overfire this unit by tampering with the controls on the unit.** Follow all instructions regarding the proper use of this heater.

## Wiring Schematic



80P30563

Figure 27

The Electrical Rating of this Stove is: 120 Volt, 60 Hz, 4 Amp with the igniter running and approximately 2 Amp with out the igniter running. The minimum recommended circuit is 15 Amp. A dedicated circuit for the Stove is recommended.

**CAUTION:** The electrical components of the Stove are not owner serviceable. Call your dealer for proper diagnosis of electrical problems and service to those components.

## TROUBLESHOOTING & FREQUENTLY ASKED QUESTIONS

The Prescott EXP and Prescott EXL models are equipped with the Versa Grate Burn System.

The Stove is very trouble free in operation when properly maintained and quality fuel is used. When the Stove fails to operate properly, troubleshooting by the operator of the Stove is limited. Please read the following guide for answers to frequently asked questions

1. When first starting your Stove the auger tube is empty and this will delay feeding fuel to the burn pot. This will in some cases prevent the Stove from starting.

**Solution:** Prime the burn pot using the Auger Feed button if the auger tube is empty.

2. **My Stove keeps overloading the burnpot.** First check the Quality of your Fuel to make sure you are using clean fuel. Otherwise this is mainly caused by improper combustion settings. (See **Damper** Adjustment section of the Operations Manual) Besides the damper adjustment there are several areas that can have an effect on the combustion process.

**Solution:** **First Clean the stove as described in the Periodic Maintenance. Then** check all Gaskets, Doors and Door Latching Systems for air leaks. Any leaks in these areas will negatively affect the burn process and cause the pot to overload.

3. **My Stove isn't burning and the number 2 LED light is blinking.** This diagnostic light indicates the vacuum switch no longer senses negative pressure in the firebox area of the Stove.

What could be the cause of this?

- a. The door of the unit was left open longer than 60 seconds. **(See solution)**
- b. The ash pan door was left open for longer than 60 seconds. **(See solution)**
- c. The combustion fan is not running. (Defective fan or control board)
- d. The vacuum switch is defective.
- e. The vacuum hose is disconnected or cracked or plugged.
- f. The vent system is plugged with fly-ash.

**Solution:** *If the fire is out*, re-light the Stove. *If the fire is still burning* make sure all doors are securely latched and hold down the On/Off button (approximately 5 seconds) until Stove starts up again. This will re-start the Stove in the start-up program.

4. **My Stove isn't burning and the number 3 LED light is blinking.** This diagnostic light indicates that the Proof of Fire Switch no longer senses a fire in the Stove. First check to see if there is Fuel in the hopper. If there is fuel in the hopper, check the following areas to find out why the Stove went out.

- a. Unburned fuel in the burnpot means the fire went out before the auger quit feeding.

Too much Combustion Air while burning on the Low Heat Level could cause the fuel to burn up too quickly and cause the fire to go out. Fuel would still feed until the P.O.F. switch eventually shuts the Stove down.

**Solution: Too much Combustion Air on the pilot setting.** Adjust the air damper or the combustion fan voltage. (See section covering *Damper Adjustment*)

- b. If all the fuel is burned up means the auger quit feeding fuel while there was still a fire in the burnpot. Check to see if there is fuel in the hopper. If the hopper is empty, fill the hopper and re-light the Stove.

If there is fuel in the hopper check to see if there is an obstruction in the auger system or if the auger set screw is loose.

**Solution:** Remove obstruction and re-light the Stove or tighten the setscrew on the auger shaft.

5. **My Stove isn't burning and the #4 LED light is blinking.** This means the high Limit has shut the Stove down. The Convection Blower could be defective or may need cleaning. The high limit switch may be also defective. It is best to call your dealer for support when trying to troubleshoot the High Limit Switch. Do not use your Stove if the High Limit switch frequently trips.

6. **I turned the Stove on with the On/Off switch and nothing happens.** First check to see if the Stove is plugged in and the receptacle has power to it.

**Solution:** Check the fuse on the back of the control board. Replace with a 125 Volt, 5 Amp fuse.

7. **Why is my glass dirty?** Normal operation of your St. Croix Stove will produce a light build-up on the glass that wipes off with a dry paper towel. However extended burning on the low setting only will produce a tan color. These types of build-up on the glass are normal. A heavy black build-up on the glass could indicate a problem.

**Solution:** Adjust the combustion air damper or combustion fan voltage. If this doesn't seem to help, make sure the clean out cover plates are installed in the Stove. It also could be an indication that the Stove is getting plugged and needs a good cleaning. Refer to the section in the manual that covers the Daily, Periodic and Yearly Maintenance of the Stove.

8. Are there any adjustments that can be made to the amount of fuel that is fed into the burnpot?

Answer: There are several ways to adjust the amount of fuel that is fed into the burnpot. The feedrates can be fine-tuned while the Stove is in operation by **pressing and holding** the “Auger Feed” button down and then **either** pressing the “Heat Level High” button to advance the feedrate higher, **or** pressing the “Heat Level Low” button to decrease the feedrate.

There are 5 levels on the control board and they are indicated by a single flash of the LED’s. The default setting is the center LED. This gives 2 adjustments increasing the feedrate (LED’s 4 & 5) and 2 adjustments decreasing the feedrates. (LED’s 1 & 2) The ON time is **increased or decreased** .25 seconds with each adjustment.

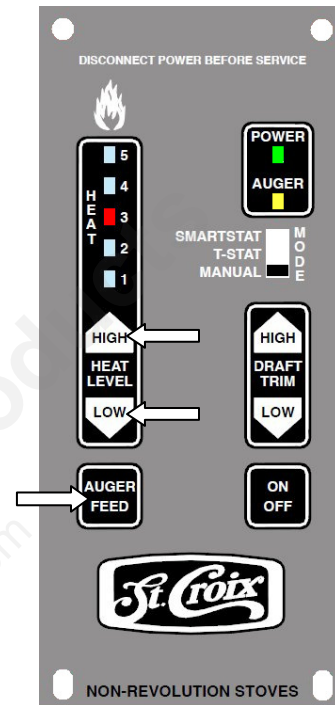

Figure 28

9. Are there any adjustments that can be made to the Combustion Fan voltages to help adjust the draft?

Answer: The Draft can be adjusted in a similar fashion as mentioned in the previous example.

The Fan voltages can be fine-tuned while the Stove is in operation by **pressing and holding** the “Auger Feed” button down and then **either** pressing the “Trim High” button to advance the voltages higher, **or** pressing the “Trim Low” button to decrease the fan voltages.

There are 5 levels on the control board and they are indicated by single flash of the LED’s. The default setting is the bottom LED. This gives 5 adjustments increasing the voltage (LED’s 2 through 5) The voltage is **increased or decreased** 2.5 volts with each adjustment.

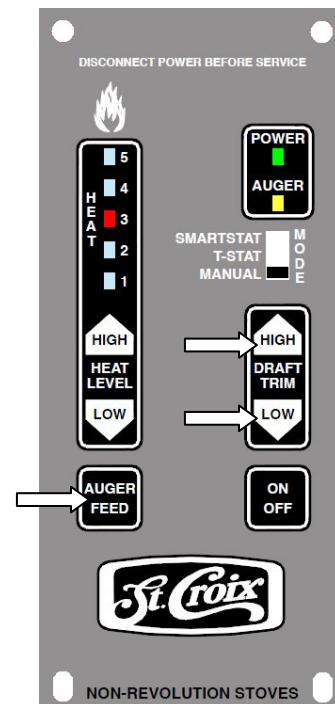

Figure 29

## 10. Are there Cycle Time adjustments on the Control Board for different types of fuel?

Answer: There are 4 individual programs on the control board; each has a different Cycle time. *The Prescott EXP and Prescott EXL only use Program 3 and Program 4*

Your Stove has been factory set to Program 3. When programming the control board, you will see LED light flash, as shown in the figure to the right. The LED lights flash in the following manner:

- 1 - **Program 1.** The Cycle Time is 11.5 seconds. **THIS PROGRAM IS ONLY TO BE USED WITH MULTI-FUEL MODELS. (DO NOT USE THIS PROGRAM WITH THE PRESCOTT EXP OR THE PRESCOTT EXL).**
- 2 - **Program 2.** The Cycle Time is 13 seconds. **THIS PROGRAM IS ONLY TO BE USED WITH MULTI-FUEL MODELS. (DO NOT USE THIS PROGRAM WITH THE PRESCOTT EXP OR THE PRESCOTT EXL).**
- 3 - **Program 3.** The Cycle Time is 11.5 seconds. **THIS IS THE DEFAULT PROGRAM FOR USE WITH THE PRESCOTT EXP AND PRESCOTT EXL.** This program is for use with PFI Premium Pellets.
- 4 - **Program 4.** The Cycle Time is 10 seconds. *This Program offers Self-Ignition and is only for units that have the Versa Grate system & Igniter installed.*

Program 4 is for adjusting for variations that occur with PFI Premium Pellets. Ask your dealer before using this Program in your unit. See page 25 for more information on variations between different brands of pellets.

## 12. How do I change the Programs on the control board?

First the Stove must be turned off and cooled down.

Step 1 - The Thermostat switch must be in the **Manual** position.

Step 2 – Press and hold the **Auger Feed** Button.

Step 3 – Press the **Trim High and Low** Buttons at the same time and immediately release all 3 buttons.

Step 4 – Observe the LED light flashing according to the Program chosen. Program 1 flashes once, Program 2 flashes twice, Program 3 flashes three times and Program 4 flashes 4 times.

Changing the Cycle Time will change the BTU Input of the Stove. The longer the Cycle time the lower the BTU rating.

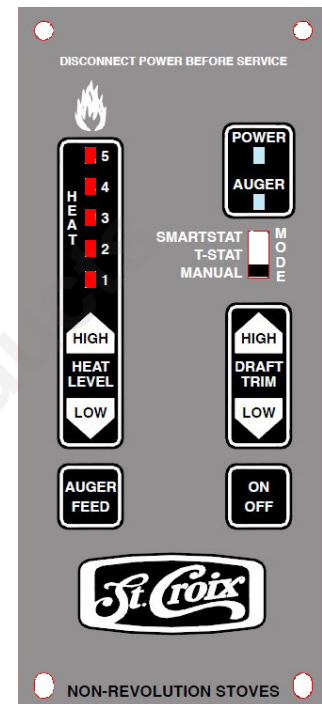

Figure 30

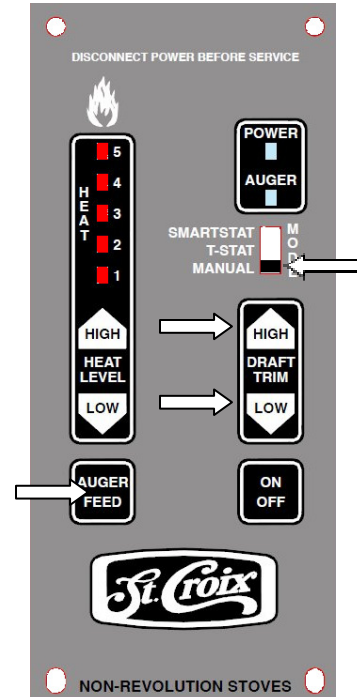

Figure 31

# PARTS LAYOUT

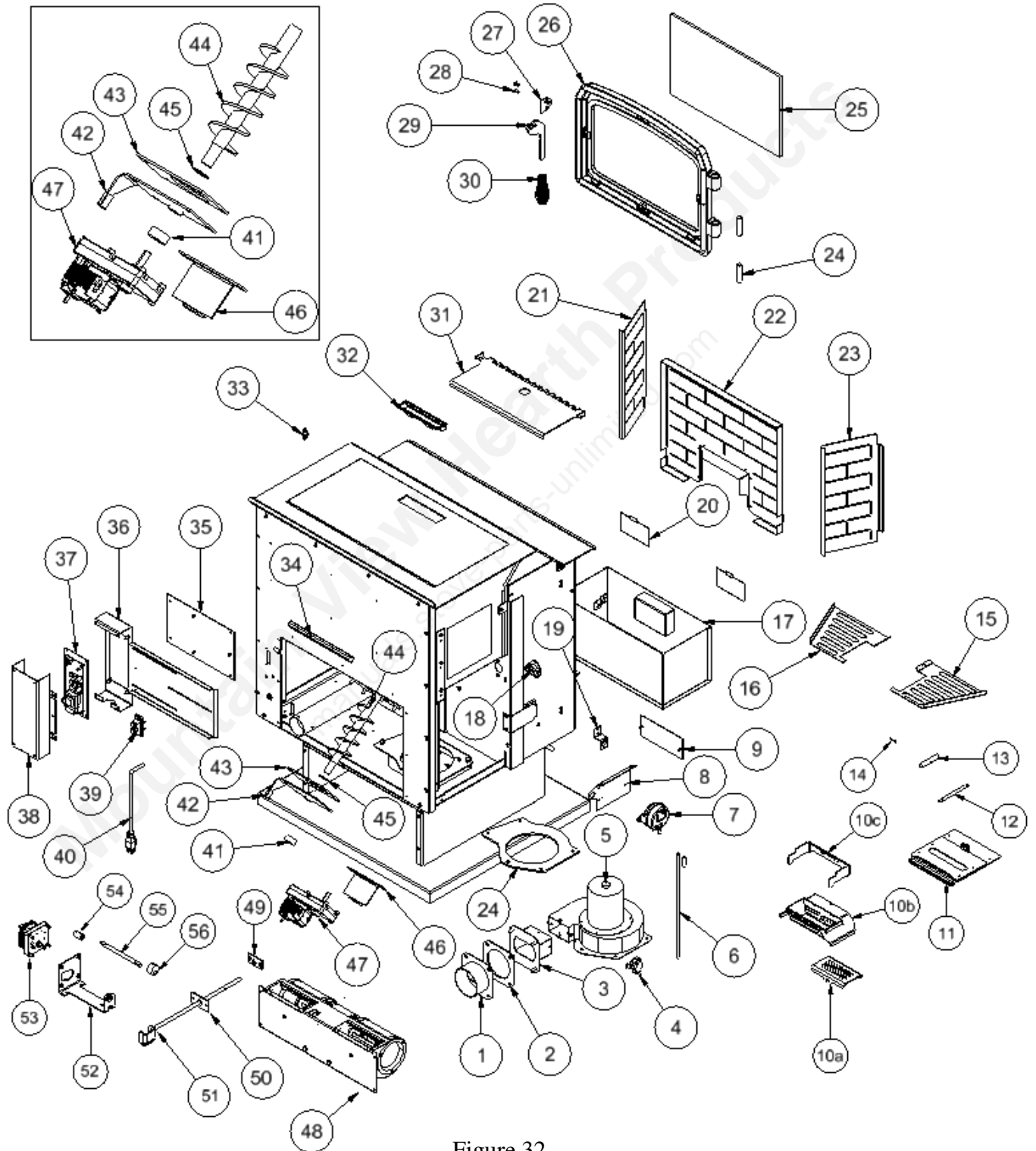

Figure 32

## PARTS LAYOUT

#	PART NUMBER	DESCRIPTION
1	80P52887-R	PIPE CONNECTOR ASSEMBLY
2	80P52232-R	QUICK DISCONNECT GASKET
3	80P53667-R	EXHAUST ADAPTER WELDMENT
4	80P20038-R	PROOF OF FIRE SWITCH
5	80P30521-R	COMBUSTION BLOWER
6	51135K282 -R	SILICONE TUBING – 15”
7	80P30658-R	VACUUM SWITCH
8	80P52710-R	VACUUM SWITCH BRACKET
9	80P30280-R	CLEAN OUT COVER (BEHIND ASHPAN)
10a	80P30940-R	SHAKER PLATE
10b	80P53884-R	GRATE WELDMENT
10c	80P31168-R	POT SIDE SHIELDS
11	80P54368-R	SLIDE OUT BOTTOM ASSEMBLY
12	80P31208-R	POT SLIDER ROD
13	80P52592-R	SLIDER ROD - UNIVERSAL
14	98355A070 -R	COTTER PIN
15	80P30049-R	DECORATIVE GRILL – LEFT SIDE
16	80P30050-R	DECORATIVE GRILL – RIGHT SIDE
17	80P53646-R	ASH PAN
18	80P52629-R	MANUAL RESET HIGH LIMIT SWITCH
19	80P54223-R	DOOR MAGNET ASSEMBLY
20	80P52237-R	CLEAN OUT COVER
21	80P30946-R	STEEL BRICK PANEL – RIGHT SIDE
22	80P54127-R	STEEL BRICK PANEL – BACK PANEL
23	80P30945-R	STEEL BRICK PANEL – LEFT SIDE
24	80P65021-R	½” DOWEL HINGE PIN
25	80P20033-R	DOOR GLASS
26	<b>80P20091-R</b>	<b>BLACK DOOR FRAME</b>
26	<b>80P20032-R</b>	<b>GOLD DOOR FRAME</b>
26	<b>80P20106-R</b>	<b>NICKEL DOOR FRAME</b>
27	80P53694-R	HANDLE MOUNT PLATE ASSEMBLY
28	10-24X3/8BSHCS	10-24 X 3/8 BUTTON SOCKET HEAD SCREW
29	80P60036-P	DOOR HANDLE - PAINTED
30	80P20036-BO	HANDLE COIL - BLACK
31	80P52366-R	HEAT EXCHANGE BAFFLE
32	80P20183-R	HANDLE PULL – HOPPER LID
33	80P31003-R	HOPPERLID SWITCH
34	80P20403	PLASTIC DUCT – 8”

#	PART NUMBER	DESCRIPTION
35	80P53681-R	SLIDE-TOP STANDOFF PLATE ASSEMBLY
36	80P53785-R	CONTROL BOARD BOX W/ CLINCH STUDS
37	80P30523B-R	CONTROL BOARD
38	80P52658-R	CONTROL BOARD HARNESS RESTRAINT
39	80P30045-R	THERMOSTAT TERMINAL
40	80P20004-R	POWER CORD
41	80P20248-R	5/8" COLLAR WITH SET SCREW
42	80P54074-R	MOTOR MOUNT BRACKET AND END CAP
43	80P20245-R	AUGER GASKET
44	80P53666-R	AUGER WELDMENT
45	80P60083-R	AUGER WASHER
46	08P30191-R	MOTOR RETAINER BRACKET
47	80P20278-R	AUGER MOTOR
48	80P20003-R	CONVECTION BLOWER
49	80P31220-R	FRONT BUSHING PLATE
50	80P31221-R	REAR BUSHING PLATE
51	80P53695-R	SHAFT/CAGE WELDMENT
52	80P52953-R	VERSA GRATE BRACKET ASSEMBLY
53	80P20296-R	VERSA GRATE MOTOR
54	80P52372-R	VERSA GRATE COLLAR W/ SETSCREWS
55	80P52376-R	CAM CONNECTOR ROD
56	80P50560-R	CAM
	<b>PARTS</b>	<b>NOT SHOWING</b>
N/A	80P31219-R	REMOVABLE BUSHING MOUNT PLATE
N/A	80P21403-R	WIRING HARNESS
N/A	80P52630-R	TERMINAL BLOCK
N/A	X-113HT	RUBBER HOPPER SEAL – 35"
N/A	80P54121-R	ROD TOOL ASSEMBLY
N/A	80P20057-R	250 VOLT 5 AMP FUSE

# **PRESCOTT SERIES WARRANTY**

The Stove manufactured by Even Temp, Inc. is warranted for five (5) years, to the original owner, against defects and workmanship on all steel parts (excluding the burn grate and Versa Grate System Parts, Baffle and Brick Panels) and two (2) year on electrical components from the date of sale to the original owner. There specifically is no warranty on the paint, glass and all gaskets. There is no written or implied performance warranty on the Stove, as the manufacturer has no control over the installation, daily operations, maintenance or the type of fuel burned.

This warranty will not apply if the Stove has not been installed, operated and maintained in strict accordance with the manufacturer's instructions. Burning other than approved quality fuels may cause Stove damage and could void the warranty.

The warranty does not cover damage or breakage due to misuse, improper handling or modifications.

A warranty registration card is provided. The card is to be checked and signed and returned to factory by the owner. Appropriate information is to be noted on the card.

All claims under this warranty must be made through the dealer where the Stove was purchased. If an inspection by the dealer indicates that a warranty claim is justified, and that all conditions of this warranty have been met, the manufacturer's total responsibilities and liabilities shall be to repair or replace, at the manufacturer's option, the defective part(s). All costs of removal, shipment to and from the dealer or manufacturer, any losses during shipment and reinstallation and any other losses due to the Stove being removed shall be covered by the owner of the Stove.

NEITHER THE MANUFACTURER, NOR THE SUPPLIERS TO THE PURCHASER, ACCEPTS RESPONSIBILITY, LEGAL OR OTHERWISE, FOR THE INCIDENTAL OR CONSEQUENTIAL DAMAGE TO PROPERTY OR PERSONS RESULTING FROM THE USE OF THIS PRODUCT. ANY WARRANTY IMPLIED BY LAW, INCLUDING BUT NOT LIMITED TO IMPLIED WARRANTIES OF MERCHANTABILITY OR FITNESS, SHALL BE LIMITED TO ONE (1) YEAR FROM THE DATE OF ORIGINAL PURCHASE. WHEN A CLAIM IS MADE AGAINST THE MANUFACTURER BASED ON THE BREACH OF THIS WARRANTY OR ANY OTHER TYPE OF WARRANTY EXPRESSED OR IMPLIED BY LAW, MANUFACTURER SHALL IN NO EVENT BE LIABLE FOR ANY SPECIAL, INDIRECT, CONSEQUENTIAL OR OTHER DAMAGES OF ANY NATURE WHATSOEVER IN EXCESS OF THE ORIGINAL PURCHASE PRICE OF THIS PRODUCT. ALL WARRANTIES BY MANUFACTURER ARE SET FORTH HEREIN AND NO CLAIM SHALL BE MADE AGAINST MANUFACTURER ON ANY ORAL WARRANTY OR REPRESENTATION.

Some states do not allow the exclusion or limitation of incidental or consequential damages, or limitations of implied warranties; therefore the limitations of exclusions set forth in this warranty may not apply to you. This warranty gives you specific legal rights, and you may have other rights, which vary from state to state.

## Notes:

After the break in period, please note any adjustments that were made to the Feed Trim and Draft Trim on the control board in the area below.

**Feed Trim: Circle one (See point 2 on page 27)**

**LED #1            LED #2            LED #3            LED #4            LED #5**

**Draft Trim: Circle one (See point 4 on page 27)**

**LED #1            LED #2            LED #3            LED #4            LED #5**

**APPROVED FUEL:**

**PFI PREMIUM PELLETS**

**PROGRAM: Circle one (see Figure 19 on page 28)**

**3                    4**

**Serial Number:**

**Date of Purchase:**

**Dealer Information:**