

# St. Croix

## PELLET STOVES

### Operation & Maintenance

#### MODELS:

- PRESCOTT This model includes: Prescott I  
Prescott II
- SCANDIA This model includes: Scandia II
- AFTON This model includes: Afton I  
Afton II  
Afton Bay  
Afton Insert
- SOMERSET
- BAYPORT

#### Table of Contents

St. CROIX FEATURES .....	1
INSTALLATION.....	2
PREVENTING CHIMNEY FIRES .....	2
SATISFACTORY PERFORMANCE .....	2
PELLETS .....	2
OPERATING INSTRUCTIONS .....	3
Pre-Lighting Instructions .....	3
Lighting Your Stove .....	5
Shutting the Stove Off .....	6
Safety Features .....	6
MAINTAINING THE STOVE .....	7
Daily Maintenance .....	7
Periodic Maintenance .....	9
Yearly Maintenance .....	10
TROUBLESHOOTING .....	10
WARRANTY .....	11

Your Dealer Is:

## Dear St. Croix Wood Pellet Stove Owner:

**Congratulations!** Your purchase of a St. Croix wood pellet stove places you among a select group of individuals who have demonstrated their concern about residential heating efficiency and our environment.

This owner's manual is designed to help you obtain maximum benefit from your St. Croix wood pellet stove.

Please read this manual in its entirety BEFORE operating your pellet stove.

During the manufacturing process every effort has been expended to ensure that each St. Croix wood pellet stove meets the highest quality standards of material and workmanship.

Here are some important aspects of wood pellet stove installation and operation which you must observe in order to obtain maximum comfort and safety from your new St. Croix wood pellet stove.

1. Have your new St. Croix wood pellet stove installed by trained, qualified personnel.
2. Use only clean, dry quality wood pellets which are known to burn satisfactorily in your stove.
3. Faithfully adhere to the maintenance program described in this manual.

Thank you for selecting a St. Croix wood pellet stove as the environmentally preferred answer to your residential heating needs.

Sincerely,



Bob Robinson  
Sales Manager  
EVEN TEMP, INC.

# St. Croix

PELLET STOVE

*with*

FULL PEDESTAL ASHPAN AND IGNITOR OPTION

## Features

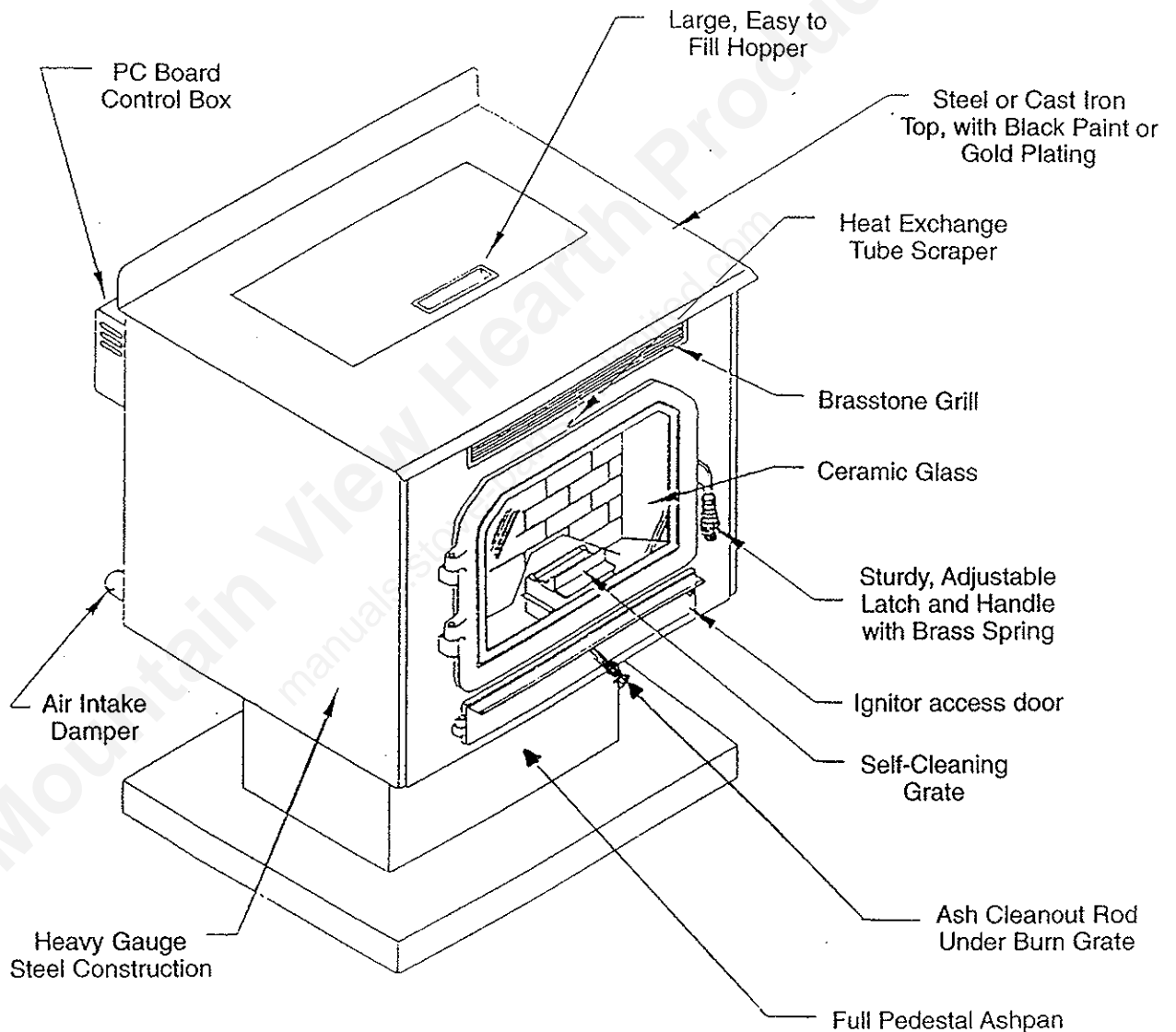

# St. Croix

PELLET STOVE

*without*

Full Pedestal Ashpan and Ignitor Option

## Features

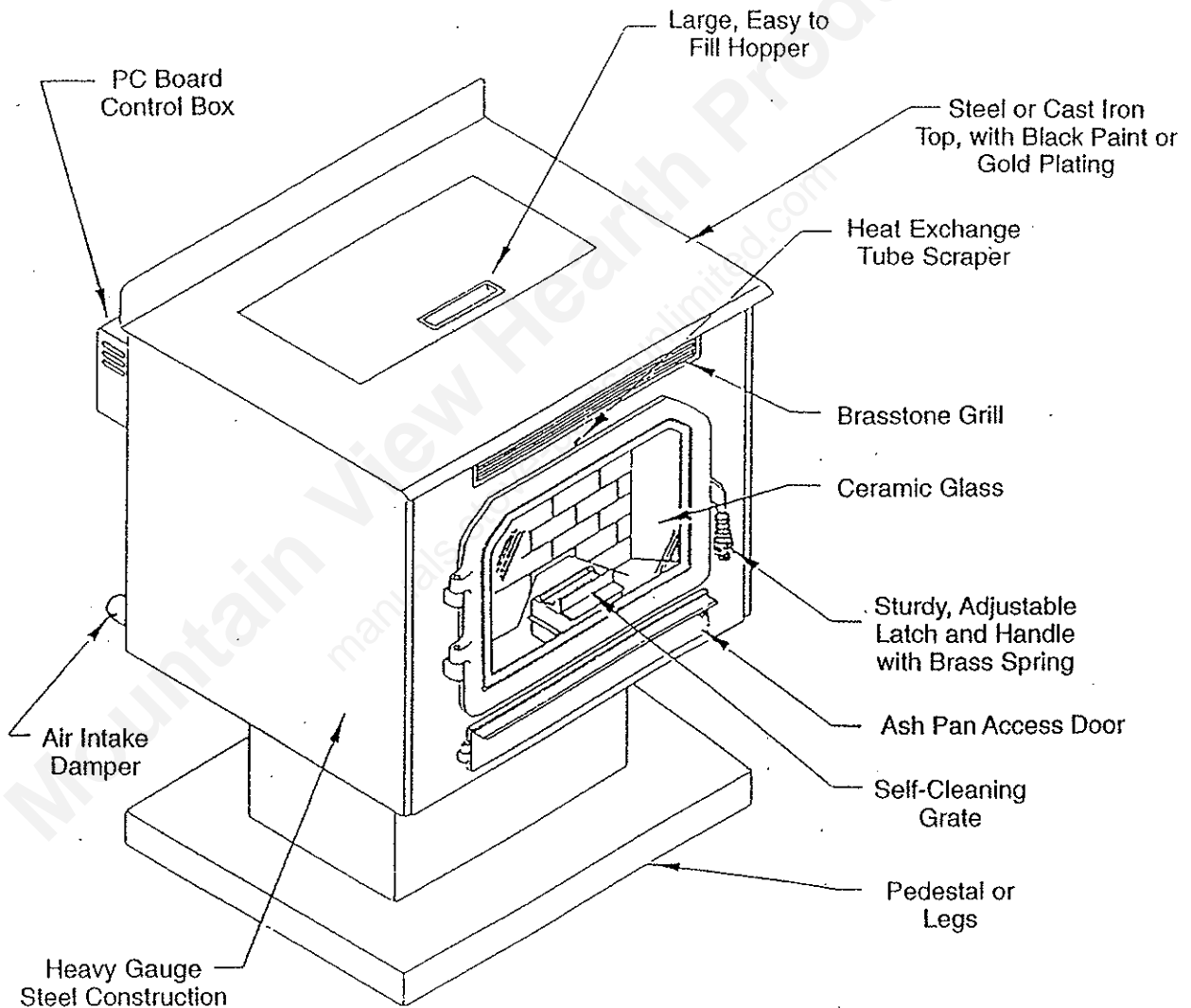

# Operation and Maintenance of the St. Croix Wood Pellet Stove

## INSTALLATION

Proper installation is essential for safety, effective operation, warranty coverage, insurance requirements and to meet local building codes. Installation requirements are described in the Installation Manual included with your new stove.

## PREVENTING CHIMNEY FIRES

Chimney fires can be prevented by properly operating the stove and by periodic inspection and cleaning of the chimney.

When wood is burned it produces tar and other organic vapors, which combine with expelled moisture to form creosote. The creosote vapors condense in the relatively cool chimney flue associated with a slow burning fire. As a result, creosote residue accumulates on the flue lining. When ignited this creosote can result in an extremely hot chimney fire.

The chimney and chimney connector should be inspected at least once every two months during the heating season to determine if a creosote build-up has occurred. If a significant layer of creosote has accumulated (3 mm or more) it should be removed to reduce the risk of a chimney fire. Use of an appropriately sized chimney brush or the services of a professional chimney sweep are recommended.

**SAVE THIS OPERATIONS AND  
MAINTENANCE MANUAL**

## SATISFACTORY PERFORMANCE

The keys to satisfactory performance are: proper operation of the stove, diligent maintenance and burning only dry, clean, quality wood pellets.

## PELLETS

The St. Croix wood pellet stove is designed to burn only premium quality wood pellets manufactured to the Association of Pellet Fuel Industries (APFI) standard for residential pellet fuels. Pellets that are soft, contain loose sawdust, are/or have been wet, produce clinkers and/or heavy ash that will not blow out of the burn grate must not be used.

Clinkers and ash are a by-product of pellet combustion and are not caused solely by your stove. Stove performance can be quickly and severely reduced if poor quality pellets are used. Contact your dealer for more information on APFI approved wood pellet fuels.

**NOTE:** Pellets with excessive sawdust may be screened by sifting with 1/4" mesh screening.

Store Pellets under cover on a wooden pallet or other methods to ensure they do not become rain soaked or absorb moisture from damp or wet floors. Do not store pellets within stove installation clearances or within the space required for ash removal.

The stoves is not warranted against damage caused by poor pellets, incorrect operation, poor maintenance or incorrect installation.

## OPERATING INSTRUCTIONS

*A different type of heater.* The pellet stove is neither a cord wood stove nor a furnace. Its operation and maintenance differ from the traditional wood stove. FOLLOW THESE OPERATING INSTRUCTIONS EXACTLY AS STATED TO ENSURE SAFE AND RELIABLE OPERATION.

1. Carefully read this "Operation and Maintenance" manual in its entirety BEFORE lighting your stove for the first time.
2. Obtain final inspection and approval of installation from local building officials.
3. Carefully clean all marks off the gold plated parts before the first fire is lighted. Use a soft cloth and a "Windex" type cleaner. **Caution:** Never use an abrasive cleaner on any plated or painted parts of the stove.
4. Have your dealer demonstrate all the operational and maintenance steps necessary for proper use of the stove. Sign and mail the warranty card, on the back page.
5. Some odors may be given off during the first few hours of burning during initial break-in. These odors are normal and not harmful. However, ventilating the room until the odors disappear is recommended.
6. The stove will become HOT while in operation. Keep children, clothing and furniture away from all stove surfaces.
7. To avoid the possibility of smoke and/or sparks entering the room, always keep firebox and de-ashing doors closed whenever the stove is operating.
8. A certain amount of carbon monoxide may be produced within the stove as a by-product of combustion. All exhaust vent connections must be sealed with RTV silicone to assure a gas tight seal. Any leaks into a confined area caused by faulty installation or improper operation of the stove could produce dizziness, nausea and in extreme cases, death.
9. An outside source of combustion air is strongly recommended and is required on all mobile home installations. If room air is used to supply combustion air, room air starvation, operation of exhaust fans and icing of air vents can adversely affect proper stove operation.
10. Smoke detectors, installed in the same general area as the stove, may be activated if the stove door is left open and smoke is allowed to enter the area.

### Pre-Lighting Instructions

Your stove is equipped with an air inlet damper. Before lighting your stove for the first time READ the following and adjust this damper accordingly. The factory setting is FULLY OPEN. The purpose of this damper is to adjust combustion air flow to match the characteristic of each specific air inlet and chimney configuration. In most installations the inlet air damper should be left in the fully open position (shown in Figure 1A). Before the final damper adjustment is made, it is necessary to break-in the stove. Break-in requires the burning of 15 bags of pellets or continuous burn for two weeks. It is desirable to have the air inlet damper fully

***WARNING:*** Direct contact with the stove while operating may cause skin burns.

open during break-in. However, if during the initial break-in period you experience difficulty keeping the stove burning or there appears to be excessive unburned pellets being evacuated from the burn grate, it may be necessary to partially close the damper. It is normal for ash and some sparks to be continually evacuated from the burn grate. This is how the grate continuously cleans itself. The equivalent of a tea cup of unburned pellets a day in the ash pan is considered normal. If, after the break-in period, you still experience a significant number of unburned or partially burned pellets being evacuated from the burn grate, you should adjust your air damper to a 45 degree position and observe operation of the stove. Further adjustment may be needed if you continue to have excess pellet evacuation. If at any time you experience your stove burning with a lazy flame and/or with black smoke curling at the flame edges you should open your air inlet damper to the point where your flame burns cleanly. If you experience problems adjusting the stove after the break-in period contact your dealer.

**NOTE:** In most installations that have a vertical rise (chimney) greater than 8 feet it will be necessary to use the air damper. In some cases the stove will operate properly with the damper fully closed.

When lighting your stove for the first time or any time you have run out of fuel; you will need to fill the hopper with pellets (ref. Figure 2 {2A}) and follow the instructions at the top of page 5. Fuel is fed from the hopper to the burn grate by an auger. The auger is driven by a high torque motor which is capable of doing **SERIOUS** harm to fingers. Keep pellets in the hopper and keep fingers and other objects away from the auger.

**WARNING:** The auger can start at any time while the stove is running.

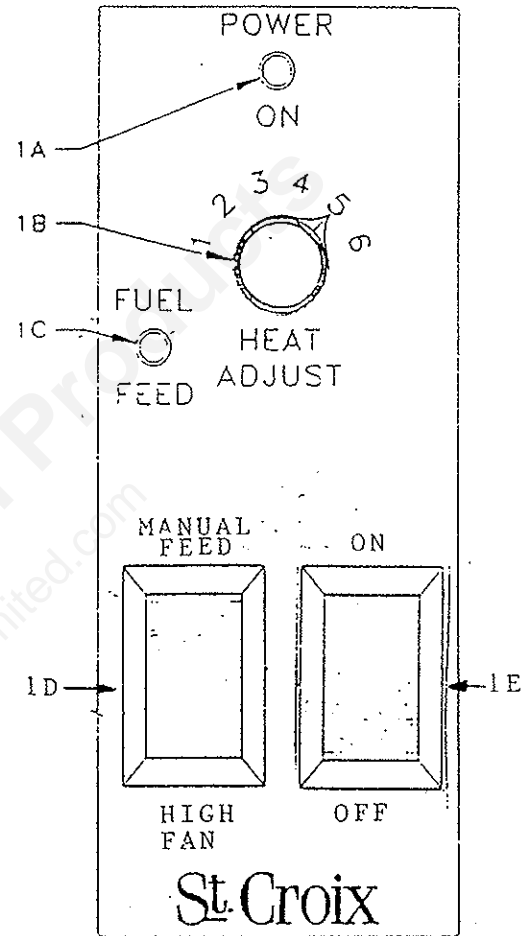
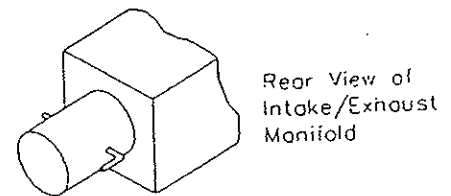

Figure 1. Control Box



Air Intake Damper Positioning

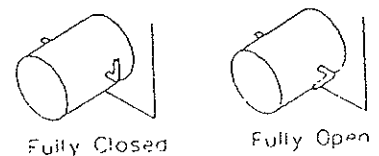

Figure 1A. Air Inlet Damper

**CAUTION:** On models with the ash cleanout system below the burn pot, the ash cleanout rod must be pushed in to operate the stove. (See ash cleanout rod in figure 1-A.)

### **Lighting Your Stove-(Pellet Stoves without Ignitor Option)**

*(Refer Fig. 1)*

1. Clean burn grate and ash pan before lighting a fire.
2. Set the HEAT ADJUST selector (1B) to position 1 (Low Burn). If your stove is equipped with a thermostat, set the thermostat to a higher setting than the room temperature.
3. Press the RUN/OFF switch (1E) down to the RUN position to supply power to the Room Air Fan, Combustion Exhaust Fan and the Self-Cleaning Grate Motor. (Auger motor will not run until the thermdisc locks in.)
4. Place approximately 1/2 cup of fire starter (such as wax coated shavings) on the burn grate. **CAUTION: Never use liquid or volatile fire starter to start your stove or start your stove when volatile liquids are present. AN EXPLOSION AND SERIOUS INJURY COULD RESULT.**
5. Light the fire starter and add approximately a cup of pellets to the fire. **DO NOT** shut the door completely at this time.
6. After the fire has completely ignited and red hot coals have formed, **SLOWLY EASE** the door shut and push the handle down.
7. If the fire starts to burn out before the auger low limit locks in, hold the manual feed button in to prime the pot.
8. After approximately 3-5 minutes or as soon as the pellets are burning briskly (red coals); set the HEAT ADJUST selector (1B) to position 6 (High Burn). Let the stove run at high setting for at least 30 minutes to bring the stove up to temperature. After this initial warm-up, set HEAT ADJUST selector (1B) as per your heating needs **OR** set your thermostat to the desired room temperature. See your Installation Manual for further information on thermostatic operation of your stove.

**NOTE:** The HEAT ADJUST selector (1B) controls the ON/OFF cycle of the Auger Motor and the speeds of both the Room Air Fan and the Combustion Exhaust Fan throughout all six position settings. Depending upon the particular pellet fuel being burned, some settings may produce better results than other.

### **Lighting Your Stove-(Pellet Stoves with Ignitor Option)**

*(Refer Figure 1)*

1. Set the HEAT ADJUST SELECTOR to position 3 and if your stove is equipped with a thermostat, set the thermostat to a higher setting than room temperature.
2. If the auger tube is empty place 1/3 cup of pellets in the burn pot. If the auger tube isn't empty, do not add pellets to the burn pot.
3. Turn the RUN/OFF SWITCH to the run position. This supplies power to the PC control board and for a period of 10 minutes to the ignitor control board.
4. During the 10 minute period the stove will feed pellets to the pot while the ignitor heats up and ignites the pellets (usually within 4-6 minutes).

5. If the auger low limit thermodisc doesn't lock in during the 10 minute start up cycle, repeat Steps 1 through 3.

**WARNING: The fire door and ash pan doors must be in the latched position for the ignitor system to work!**

6. After the pellets are burning briskly, set the HEAT ADJUST SWITCH to position 6. Let the stove run at high for 30 minutes to bring the stove up to temperature. After this initial warm up, set the HEAT ADJUST SWITCH to the desired setting or set your thermostat to the room temperature that you want.

### Shutting The Stove Off

*(Refer Figure 1)*

1. Press the RUN/OFF switch (1E) down to the OFF position to turn off the auger feed system; the fire will go out in a few minutes.
2. As long as the temperature within the stove remains above 120°F, the Room Air Fan and the Combustion Exhaust Fan will continue to run at reduced (low Burn) speed. Meanwhile the Self-Cleaning Grate continues to run at normal operating speed. When the temperature within the stove drops below 120°F, the Room Air Fan, Combustion Exhaust Fan and the Self-Cleaning Grate Motor will turn off.
3. **NEVER unplug the stove to shut it off, doing so may cause a significant amount of smoke to enter the room.**

### Safety Features

1. **OVERHEATING.** An overheat safety switch will shut off the fuel feed if the stove reaches a temperature above normal operating temperature. The stove will need to be manually relit. Allow the stove to cool for 45 minutes before relighting. If this condition repeats, call your dealer for a service inspection.
2. **LOW LIMIT.** A "Low Limit" safety switch supplies power to the Room Air Fan, Combustion Exhaust Fan and the Self-Cleaning Grate Motor while the temperatures within the stove remain above 120°F if the RUN/OFF switch (1E) is switched to the OFF position.
3. **LOW LIMIT FOR AUGER MOTOR.** Shuts auger off if the fire goes out in the burn pot for any reason.
4. **PRESSURE SWITCH.** If the exhaust venting system becomes clogged or obstructed, the fuel feed will shut down.  
  
When stove cools, follow instructions on page 9 "Periodic Maintenance", point 6.
5. The St. Croix wood pellet stove has been safety tested by an accredited, independent laboratory.

**WARNING:** These safety features are designed to protect life and property. Bypassing these features voids all warranties and the safety listing of the stove.

## MAINTAINING THE STOVE

### Daily Maintenance

The stove requires a minimum amount of daily maintenance. Required maintenance depends largely upon the quality of pellet fuel burned and the rate of burn. The amount of daily maintenance will increase if fuel quality decreases and/or the burning rate of pellets increases.

**NOTE: FAILURE TO KEEP YOUR STOVE CLEAN, AS DESCRIBED IN THIS MANUAL, COULD RESULT IN POOR OPERATION, INEFFICIENT FUEL USAGE AND A POSSIBLE SAFETY HAZARD! IT IS YOUR RESPONSIBILITY TO DETERMINE NEEDED MAINTENANCE FREQUENCY.**

All models are equipped with the Self-Cleaning Grate. The benefit of this feature is that the stove can operate for several days, with most fuels, without the grate requiring cleaning. If the flame becomes dark orange, is accompanied by black smoke or burns with a lazy motion -- its time to clean the grate. Remember, cleaning frequency may change dramatically from one fuel to another. Pellets with a high ash content or that have increased amounts of impurities or high moisture content will require more frequent cleaning. When you first operate your stove or whenever you change fuels check to determine needed cleaning frequency.

1. Check grate bottom (Figure 3) to determine if holes are plugged. Clean as needed. With proper precautions the grate may be partially cleaned while the stove is hot. Follow these steps:

(CAUTION: THE DOOR AND FRONT PART OF THE STOVE WILL BE HOT. DO NOT TOUCH ANY PART OF THE STOVE THAT IS HOT!).

- a. Wear a leather glove that covers the lower arm.
- b. Turn the auger feed system OFF and allow the flame to subside to glowing coals.
- c. Open the firebox door slowly to prevent drawing ash or odors into the room.
- d. Use the "scraper" provided to move the burning pellets, to one side of the grate, leaving the ash in the bottom of the grate.
- e. Rake the ash out over the grate into the ash pan.
- f. Rake the burning pellets across the bottom of the grate.
- g. Close the door.
- h. Turn the auger feed system back ON and check to see if the stove continues to burn. If the stove does not relight, immediately shut down the stove by returning the auger feed system to the OFF position. Let the stove cool and relight the fire.  
CAUTION: NEVER ADD FIRE STARTER TO A HOT STOVE.

2. Remove and inspect ash buildup under the grate bottom (Figure 3) after 1 to 3 days of burning.

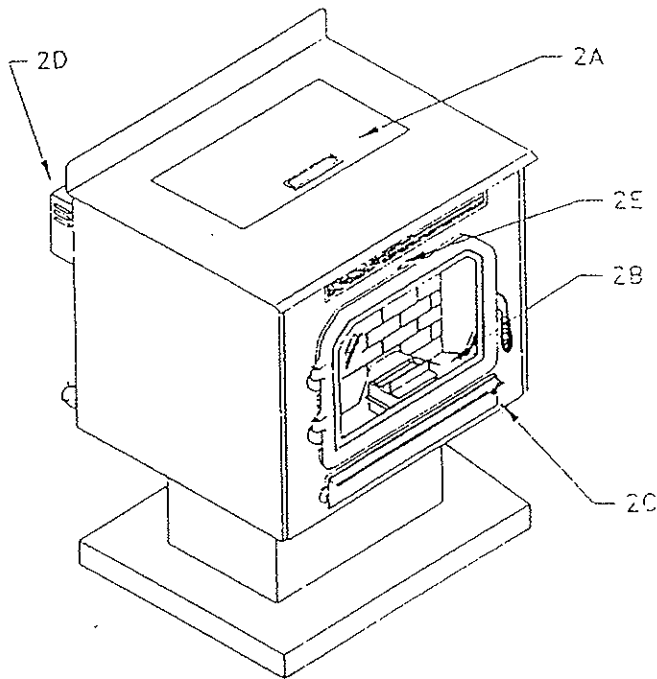

Figure 2.

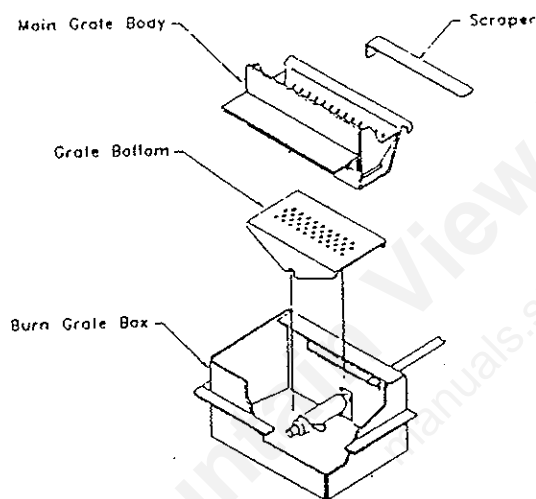

Figure 3. Self-Cleaning Grate

3. Check ash pan (Figure 2. {2B}) to determine emptying frequency needed. If you have the Bayport model, the bottom grill must be removed (see NOTE in item 5 below). NOTE: Do not use a vacuum cleaner for this purpose. Hot coals may cause your vacuum filter to catch fire. Place ashes in a metal container with a tight fitting lid. The closed container of ashes should be placed on a noncombustible floor or on the ground, well away from all combustible materials, pending final disposal. If the ashes are

disposed of by burial in soil or otherwise locally dispersed, they should be retained in the closed container for at least two days until all cinders have thoroughly cooled.

4. Check exhaust clean outs located behind ash pan by removing ash pan from stove thru ash pan access door (Figure 2 {2C}). Use scraper shown in (Figure 3) to scrape ash into ash pan. IT IS CRITICAL THAT YOU KEEP ASH CLEAN OUTS CLEAN FOR SATISFACTORY PERFORMANCE.

5. Once or twice daily pull the Heat Exchange Tube Scraper, (Figure 2 {2E}) out and back to clean heat exchange tubes. Failure to operate the tube scraper daily may result in poor combustion and loss of heat output. This should be done when the stove is cool or operating on the low temperature setting. See Figure 24 (page 24 of the Installation Manual) if visual is needed. NOTE: On the Bayport model the top grill must be removed in order to use the tube scraper. This may be accomplished by lifting and sliding the bottom of grill out towards you, then pulling down past the pin mounts.

6. The rate of burn and the quality of fuel will determine how often the window needs cleaning. Prolonged burning at a slow burn rate will result in the need for more frequent window cleaning. Burning poor fuel also increases the need to clean the window. Cooling the stove and wiping the window daily with a cloth or paper towel will normally keep the window from accumulating difficult to clean residue. Use of a glass cleaner ONLY permitted when the stove is cold.

**CAUTION:** Do not slam the door. Do not operate the stove with a broken or cracked glass. Replace only with heat resistant ceramic glass supplied by the manufacturer.

7. Burn the stove at the HI fuel setting for at least 20 to 30 minutes each day. This helps keep the window, ceraboard and firebox area clean. A daily high burn also aids in maintaining the overall efficiency and performance of the stove.
8. On full pedestal ashpan models, clean the ashes out from under the burn pot by pulling the ash cleanout rod in and out several times.

**CAUTION: The ash cleanout rod must be pushed all the way in during operation of the unit.**

### Periodic Maintenance

**CAUTION:** Periodic maintenance should only be done while the stove is shut off and cold.

1. Empty the ash pan when it appears full (may range from 1 to 5 or more days and on full pedestal ashpan models every 3 to 4 weeks). The frequency of cleaning the ash pan will depend on the quality and amount of pellets being used. Carefully check to make sure the ash pan door is tightly closed after each opening.
2. Clean out the ash traps behind the ashpan at least once a week. The cleanout holes to these ash traps are opened each time the ash pan is removed.
3. Full pedestal ashpan stoves have 2 exhaust cleanouts located below the rear ceraboard. Remove covers and clean regularly.

4. Clean burn grate holes at least weekly. Remove the burn grate. Use a small metal object to clean out plugged holes.
5. Clean under, behind and inside the burn grate box weekly. An accumulation of ash in or under the burn grate box may inhibit the proper flow of air to the burn grate.
6. Periodic cleaning of the exhaust system is required. Under certain conditions creosote buildup may occur rapidly. Low quality pellets and poor installations require more frequent chimney cleanings. See Page 2 "Preventing Chimney Fires". The products of combustion will also contain small particles of flyash. The flyash will collect in the exhaust vent and restrict the flow of the flue gases.

Judge the frequency of cleaning by checking the amount of ash that accumulates in the elbows or tee's of the exhaust system. Ask the dealer for suggested frequency of cleaning, equipment needed and procedures for cleaning. Check the exhaust system at least once every two months during the heating season.

7. Periodically inspect the condition of the rope gasket around the door, window and ash door. Replace as needed.

Many dealers offer a Service Contract that will cover needed periodic and yearly maintenance. Contact your St. Croix dealer for assistance in maintaining your stove in top condition.

## Yearly Maintenance

Yearly maintenance is designed to assure safe operation, prolong the life of the stove and help preserve its' aesthetic appeal.

1. **Spring Shutdown.** After the last burn in the spring, cool the stove. Remove all pellets from the hopper and the auger. Thoroughly clean the burn grate, burn grate box, ash pan and ash traps behind the ash pan.
2. The exhaust system should be thoroughly cleaned at least annually. Call your dealer for this service.
3. The motor/fan area behind the firebox and under the hopper should be vacuumed annually. **NOTE: UNPLUG THE STOVE.** Open the side panels of the stove. Carefully clean or vacuum any sawdust, cobwebs and household dust. Carefully vacuum around the fan motors. If electrical wires become disconnected call your dealer for service.
4. The exhaust fan should be removed and cleaned annually. Call dealer for this service.
5. Annual oiling of the motors IS NOT required. (Oiling the convection fan is recommended every burn season).
6. **Fall Startup.** Prior to lighting the first fire check the outside area around the exhaust and air intake systems for obstructions. Try all controls to see that they are working prior to lighting a fire.

## TROUBLESHOOTING

The stove is very trouble free in operation when properly maintained and quality pellets are used. When the stove fails to operate properly, troubleshooting by the operator of the stove is limited to proper cleaning of the stove and the exhaust system, proper control setting and pellet quality.

**CAUTION:** The electrical components of the stove are not owner serviceable. Call your dealer for proper diagnosis of electrical problems and service to those components.

## **St. Croix Pellet Stove WARRANTY**

The wood pellet stove and insert manufactured by Even Temp, Inc. is warranted for five (5) years, to the original owner, against defects and workmanship on all steel parts (excluding the burn grate) and one (1) year on electrical components from the date of sale to the original owner. There specifically is no warranty on the paint, glass, burn grate, cera board and all gaskets. There is no written or implied performance warranty on the stove as the manufacturer has no control over the installation, daily operations, maintenance or the type of fuel burned.

This warranty will not apply if the stove has not been installed, operated and maintained in strict accordance with the manufacturer's instructions. Burning other than high quality wood pellets that meet A.P.F.I. specifications may cause stove damage and could void the warranty.

The warranty does not cover damage or breakage due to misuse, improper handling or modifications.

A warranty registration card is provided. The card is to be checked and signed and returned to factory, by the owner. Appropriate information is to be noted on the card.

All claims under this warranty must be made through the dealer where the stove was purchased. If an inspection by the dealer indicates that a warranty claim is justified, and that all conditions of this warranty have been met, the manufacturer's total responsibilities and liabilities shall be to repair or replace, at the manufacturer's option, the defective part(s). All costs of removal, shipment to and from the dealer or manufacturer, any losses during shipment and reinstallation and any other losses due to the stove being removed, shall be covered by the owner of the stove.

NEITHER THE MANUFACTURER, NOR THE SUPPLIERS TO THE PURCHASER, ACCEPT RESPONSIBILITY, LEGAL OR OTHERWISE, FOR THE INCIDENTAL OR CONSEQUENTIAL DAMAGE TO PROPERTY OR PERSONS RESULTING FROM THE USE OF THIS PRODUCT. ANY WARRANTY IMPLIED BY LAW, INCLUDING BUT NOT LIMITED TO IMPLIED WARRANTIES OF MERCHANTABILITY OR FITNESS, SHALL BE LIMITED TO ONE (1) YEAR FROM THE DATE OF ORIGINAL PURCHASE. WHEN A CLAIM IS MADE AGAINST THE MANUFACTURER BASED ON THE BREACH OF THIS WARRANTY OR ANY OTHER TYPE OF WARRANTY EXPRESSED OR IMPLIED BY LAW, MANUFACTURER SHALL IN NO EVENT BE LIABLE FOR ANY SPECIAL, INDIRECT, CONSEQUENTIAL OR OTHER DAMAGES OF ANY NATURE WHATSOEVER IN EXCESS OF THE ORIGINAL PURCHASE PRICE OF THIS PRODUCT. ALL WARRANTIES BY MANUFACTURER ARE SET FORTH HEREIN AND NO CLAIM SHALL BE MADE AGAINST MANUFACTURER ON ANY ORAL WARRANTY OR REPRESENTATION.

Some states do not allow the exclusion or limitation of incidental or consequential damages, or limitations of implied warranties, therefore the limitations of exclusions set forth in this warranty may not apply to you. This warranty gives you specific legal rights, and you may have other rights which vary from state to state.