



***TRAVIS INDUSTRIES TRAINING
YOUR SUCCESS IS OUR BUSINESS***

Pellet Appliance Troubleshooting Guide

Copyright © 2009

Travis Industries, Inc.

Mountain View Hearth Products
manuals.stove-parts-unlimited.com

Appliance Operation Principles

Pellet Appliance Operation Sequence	1-2
Auger Feed Rate Timing	3
Power Outages	4-5

Mountain View Hearth Products
manuals.stove-parts-unlimited.com

Pellet Appliance Operation Sequence

- Pellet appliance operation sequence is important to understand when servicing pellet appliances.
- Below are the steps our pellet appliances go through. The following page provides a detailed flow chart of what happens in each step.

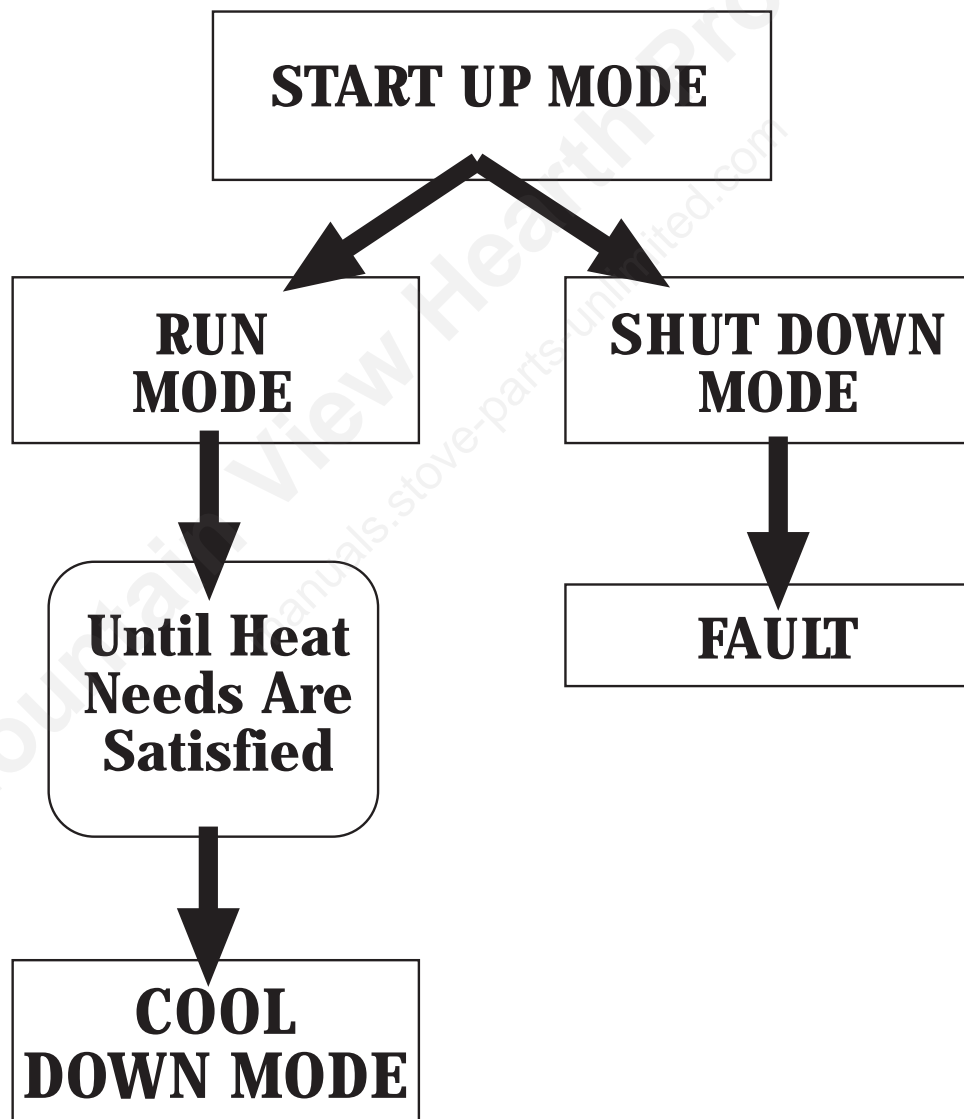

Operating Pellet Sequence

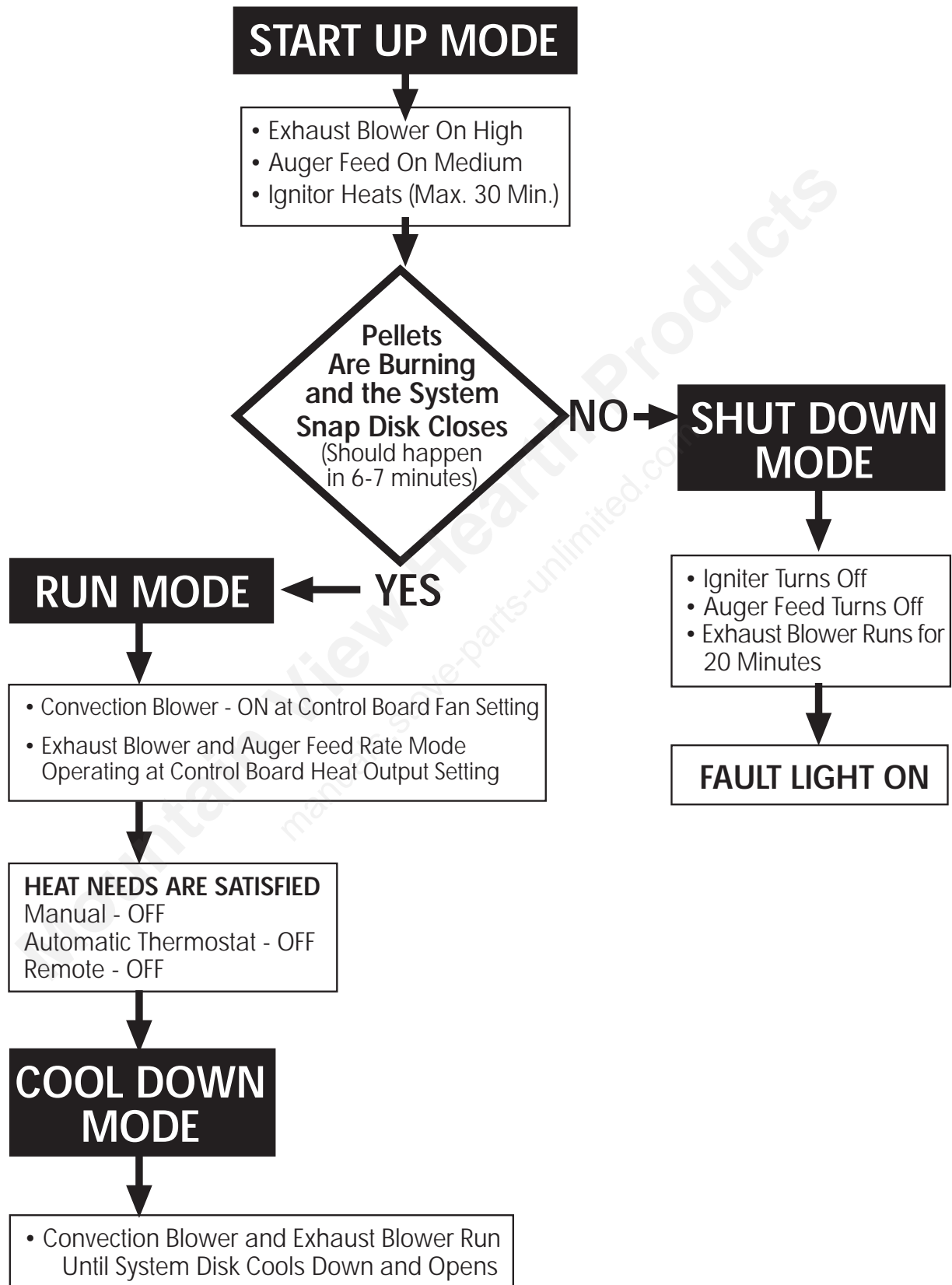

Auger Feed Rate Timing

- The feed rate of the pellets is determined by the ON/OFF cycling of auger motor. Remember the auger motor turns at a constant speed of 1 RPM. Therefore, to vary the pellet feed, we control the on and off time of the auger motor.
- In the box below you will see the ON/OFF rates:
- The auger feed light on the control board will be lit for the following times

HIGH ON 3 Seconds
HEAT OUTPUT OFF 2 Seconds

MEDIUM ON 3 Seconds
HEAT OUTPUT OFF 6-9 Seconds

LOW ON 3 Seconds
HEAT OUTPUT OFF 12-15 Seconds

Power Outage

In manual or Remote Control (ON/OFF) operation

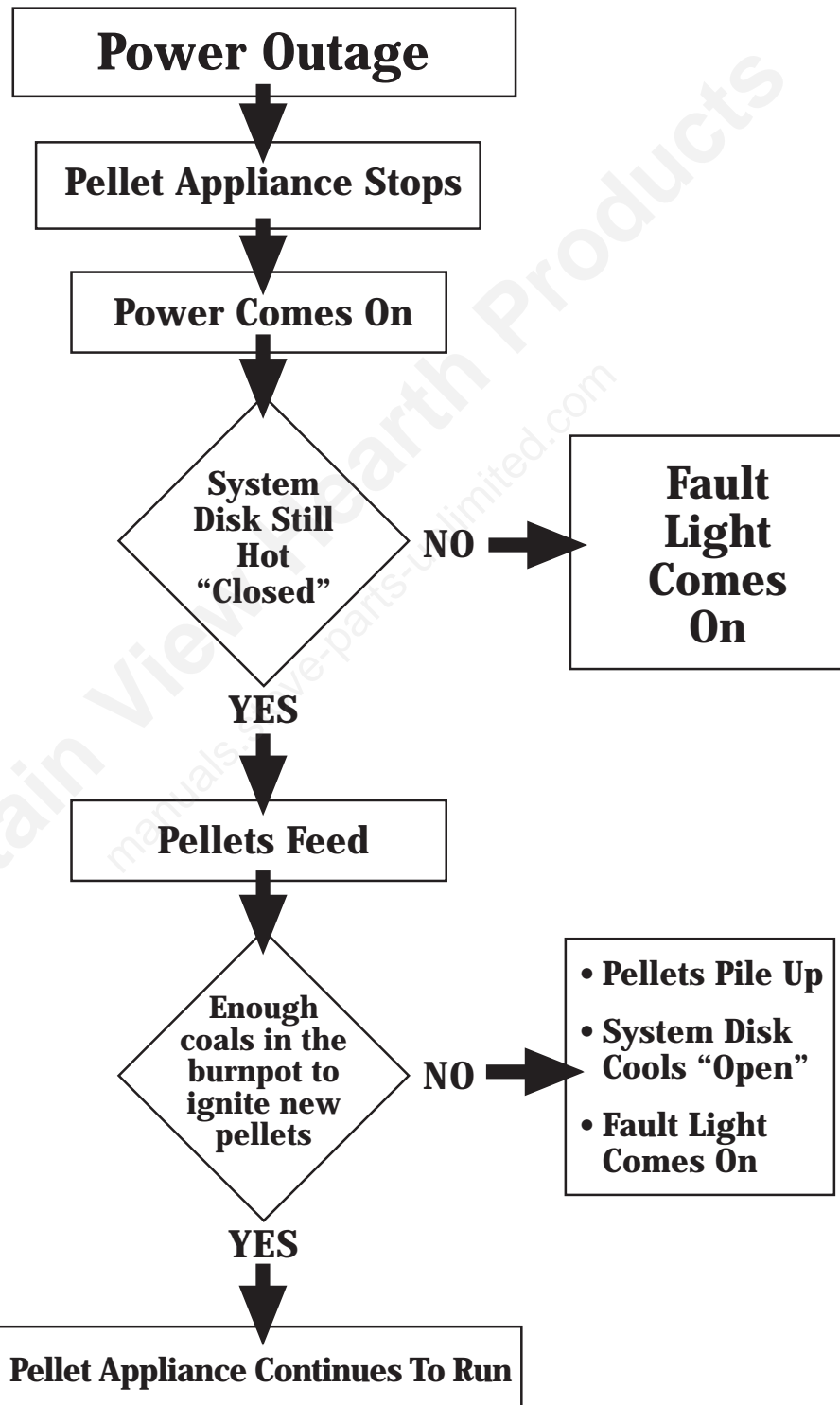

Power Outage

In automatic operation (Wall Thermostat or Remote Control)

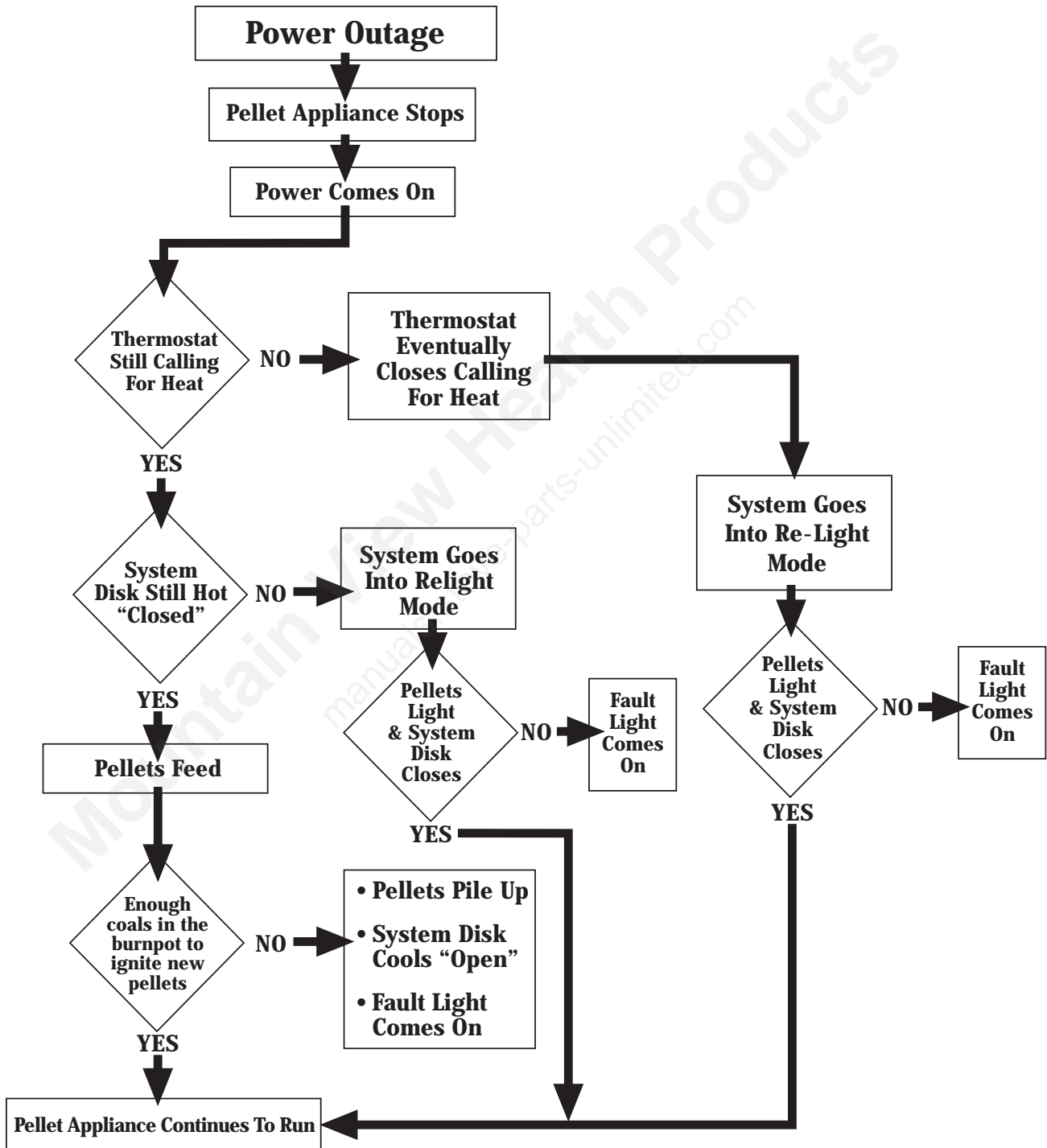

Pellet Troubleshooting Flow Chart

Pellet Troubleshooting Flow Chart

1-3

Mountain View Hearth Products
manuals.stove-parts-unlimited.com

With the appliance ON/OFF switch off,
unplug and replug the power cord

Convection
Fan or Exhaust
Blower
Comes
On

NO

START UP MODE

Power Up Unit & Push
Start Button

- Continuity test convection blower
- BAD - Replace
- GOOD - Continuity test pathway from - pin #5 - to the end of the brown wire
- From pin #7 to the end of the white wire
- Check system disk for closed when it should be open
- If everything is GOOD - Replace board

YES

Board
Lights Up

NO

- Check 110V supply
- Check power cord
- Check for proper wiring configuration
- Check Main fuse
- Check board fuse
- Check continuity from #3 pin to the fuse lead
- Check continuity from pin #7 to white power wire
- Replace board

YES

Exhaust
Blower On

NO

- Continuity test blower
- BAD - Replace
- Good - Check continuity pathway from #4 pin to black wire - from #7 pin to white wire
- BAD - Replace wiring from harness
- GOOD - Replace board

YES

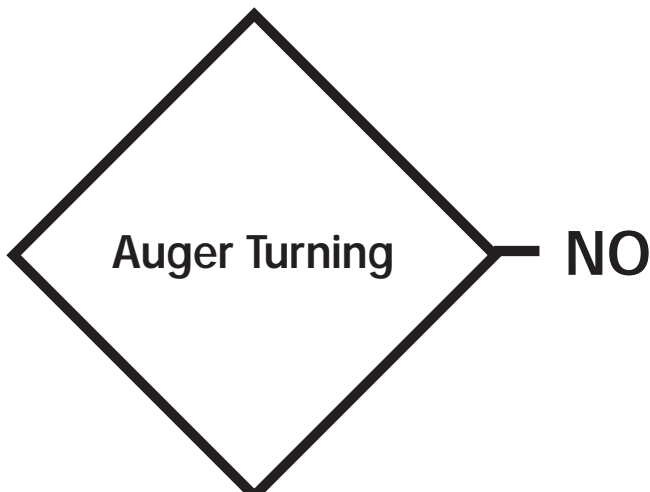

- Check for pinched vacuum hose or blocked hose on flow switch (Tube & barbed connector)
- Continuity test auger motor
- BAD - Replace
- GOOD - Check pathway (check continuity from pin #6 to end of RED power wire, check Snap Disk(s) continuity, check Flow Switch, check pin #7 to the end of WHITE wire)
- BAD - Replace defective item(s)
- GOOD - Replace bBoard

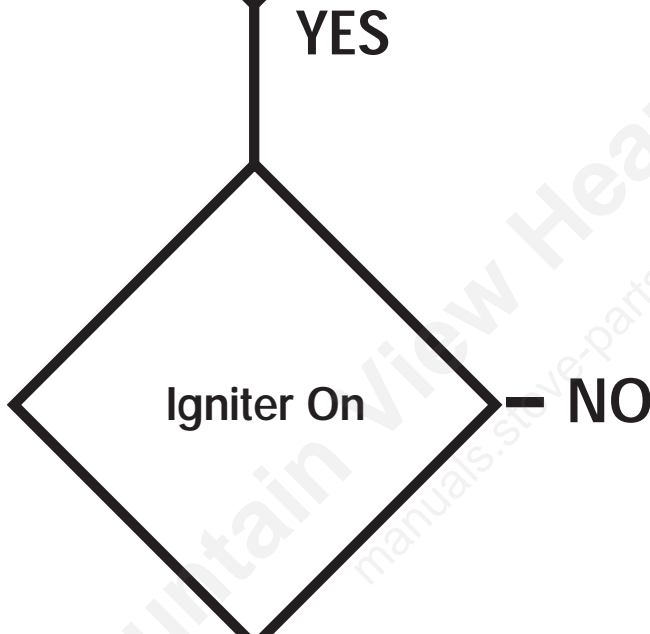

- Continuity test igniter
- BAD - Replace
- GOOD - Continuity test pathway - #1 Pin to BLACK Wire - #7 Pin to WHITE Wire
- BAD - Replace Wire Harness
- GOOD - Replace Board

Move to RUN Mode by Jumping the System Disk with a Jumper Wire

RUN MODE

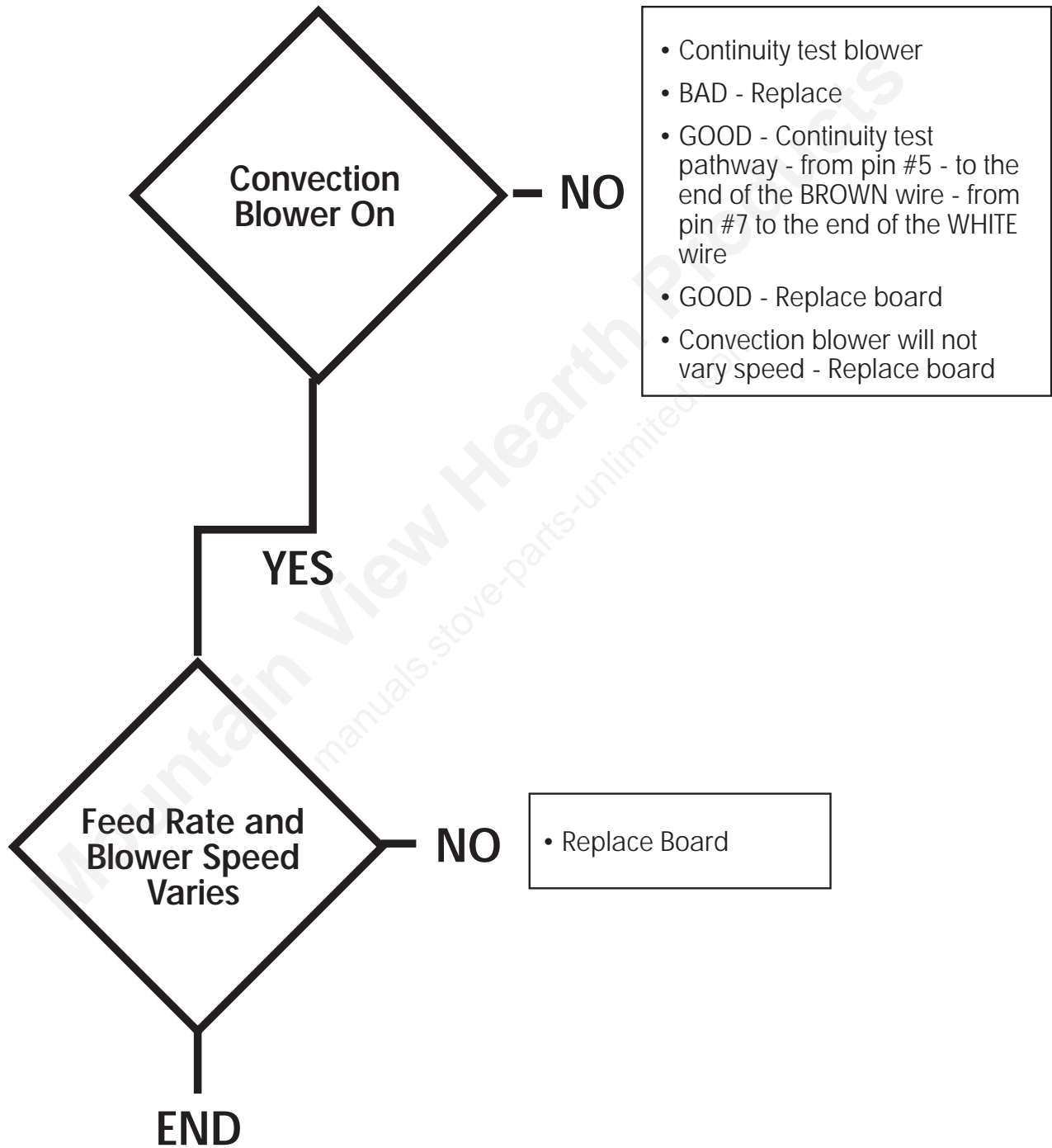

Troubleshooting Testing

Configuring the New Pellet Control Board	1-5
Wiring Diagram	6-7
Control Board Operation	8-13
General Troubleshooting Tips	14
Required Testing Equipment	15-16
Power Cord Testing Pellet Components	17-18
Continuity Testing Pellet Stove Components	19-20
Continuity Testing Wiring Harness	21-24
New Pellet Board Auger Timing	25

Mountain View Hearth Products
manuals.stove-parts-unlimited.com

Configuring the Control Board

Overview

The new AVR control board is the next generation control board that is compatible with all pellet stoves and inserts, large and small manufactured from 1997 to today. Circuitry on the board allows it to be programmed for either the large or small pellet heaters (these heaters use different voltage settings). See “” for details. It also includes a diagnostic feature that allows a service person to diagnose a fault without having to inspect the wiring or components. The indicator lights on the control board will display a fault code after a fault has been detected. This allows the service person to determine which component caused the fault. See “Diagnostic Codes” for details. NOTE: the new wiring harness (250-00017) is required to utilize this feature.

Configuring for Large or Small Heaters

The control board is initially configured for the large heaters (Astoria and Yankee models). To change the configuration the control board must be in the off position plugged into a cold stove, (no lights or running components) with the jumper molex removed (see the illustration below). In this condition press and hold the manual auger button down and press both fan up and fan down arrow keys at the same time. All heat output lights will flash. One flash denotes the large pellet heater configuration. Two flashes denote the small pellet heater configuration (Newport and Pioneer models). Repeat pressing the keys until the correct configuration is obtained.

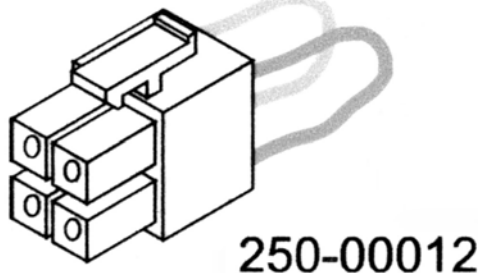

Configuring the Control Board

Using this Control Board with Older Wiring Harnesses

When the control board is installed on an older wire harness the 4 pin molex jumper plug on the back of the control board next to the stock wire harness must be installed. This jumper replaces the diagnostic wires (see “”) that are present on the new wiring harness. The control board will work normally, but the diagnostic capabilities will not function.

Technical Notes for Operation

The new pellet control board is essentially the same as our old board. The biggest difference between them is that buttons were used in place of knobs on the heat and fan controls.

Make sure to give the home owner the “Pellet Heater Operating Instructions” if you are replacing an older board (the final 4 pages of this instruction sheet). It contains the new operating instructions for this control board.

A few changes were made to accommodate the new control board. The start up cycle indicator on the old board illuminates all heat output indicator lights to show the unit is in a start-up cycle and adjusting the heat setting knob would not change them. On the new board to enable adjusting the run settings during start-up we made the start-up indicator the blinking #1 heat output light. If the #1 heat output light is blinking the board is in a start-up mode and the blower and auger outputs can not be adjusted. The run settings the unit will go to after start-up are displayed on the heat output indicator. These settings can be adjusted any time during start up by pushing the up or down heat buttons on the panel. When the fan setting is adjusted up or down the heat output indicators will turn off and the fan setting will display.

Another feature we added to the control board is a manual auger feed. This button can be used to prime and empty the auger or speed the initial delivery of pellets to the burn pot. All start-up timing remains the same and the stove will still self prime the auger tube – this option allows the operator an additional option. It is not needed for normal operation.

All voltage outputs and feed rates remain the same as the old board. There is a difference in respect to the auger on/off times. The auger timing was changed to shorten the interval between pellet drops to the burn pot. For example, on low the auger used to turn for 3 seconds and remain off for 13 seconds, for this same condition this control board turns the auger for 2.5 seconds and remains off for 10.7 seconds. This produces the same amount of time the auger is turning and not turning but gives a steadier flame height and less incidental outages on low.

Configuring the Control Board

Diagnostic Codes (Qualified Service Personnel Only)

- Fault and #2 (LOW) Light Flash = Flow Switch Fault
- Fault and # 4 (MED) Light Flash = System Snap Disk Fault (pellets run out & stove goes cold)
- Fault and # 6 (HIGH) Light Flash = Safety or Hopper Snap Disk Fault

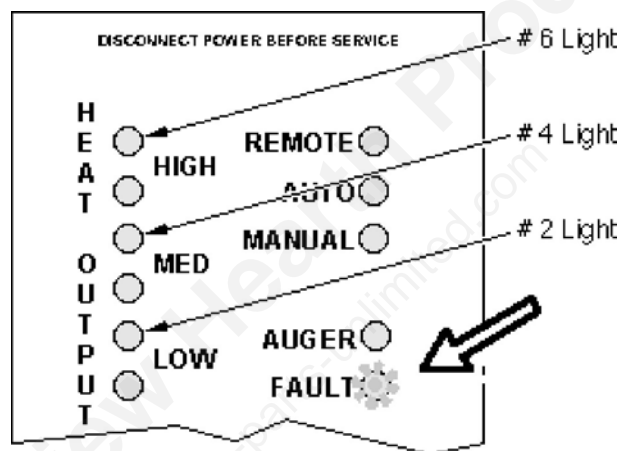

Flow Switch Fault

Fault light and #2 heat indicator blinking.

This fault code indicates pressure/flow switch opened or broke its electrical connection during operation.

Likely causes:

- Pinched, cracked or broken pressure tubing.
- Plugged tubing nipple on blower housing.
- Heavy ash build up in the exhaust fan housing,
- Faulty wiring, bad or broken connection of flow switch gray wires.
- Weak or bad combustion blower
- Faulty pressure switch.

Configuring the Control Board

Diagnostic Codes (Qualified Service Personnel Only) - Continued

System Snap Disk Fault

Fault light and #4 heat indicator blinking.

This fault code is caused by a heat sensitive switch that tells the control board if the appliance is hot or cold. During operation if the unit runs out of pellets or loses its fire this switch will communicate to the control board that the stove is getting cold. The control board will shut off the auger functions and initiate a twenty minute combustion fan safety cool down. Another condition that will trigger this fault code is a failed start. When the appliance is started the control board initiates a 30 minute timer, if the appliance is cold at the end of this 30 minute start up timer the control board will indicate a #4 fault and initiate a 20 minute combustion fan cool down.

Likely causes:

- Unit ran out of pellets.
- Fire went out during operation.
- Unit was cold at the end of a start cycle (fire did not light).
- Faulty snap disk.

Configuring the Control Board

Diagnostic Codes (Qualified Service Personnel Only) - Continued

Safety or Hopper Snap Disk Fault

Fault light and #6 heat indicator blinking.

This fault code is caused by the safety or hopper snap disk registering an over-heated appliance during operation. The control board then shuts down the auger and the convection and combustion blower will run at maximum output for a 40 minute safety cool down cycle. The only way to stop this cool down is to unplug the appliance to reset the control board.

Likely causes:

- Faulty snap disk
- Corroded, loose or broken Snap Disk wiring.
- Failed, plugged or blocked convection blower.
- Reduced air flow into the motor compartment such as blocked air vents on panels or doors.
- Missing refractory.
- Improper fuel type.
- Unauthorized parts used in the pellet feed system.

Wiring Diagram (New, 2005 Version - 250-00017)

Pellet Wiring Diagram

(wiring harness 250-00017)

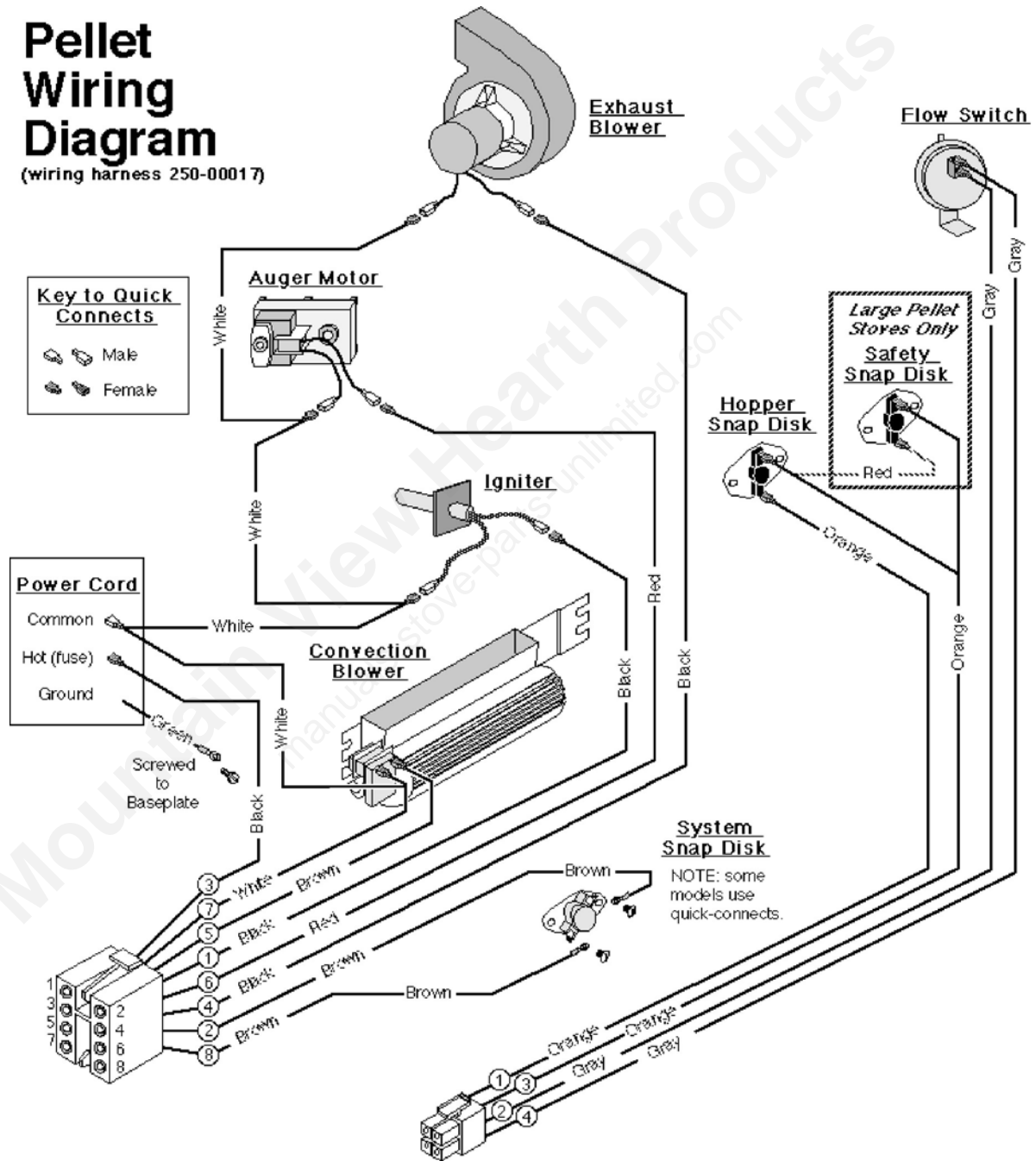

Wiring Diagram (Old Version - 100-00393B)

NOTE: Wire coloring may not be identical to this diagram

Pellet Wiring Diagram

(wiring harness 100-00393B)

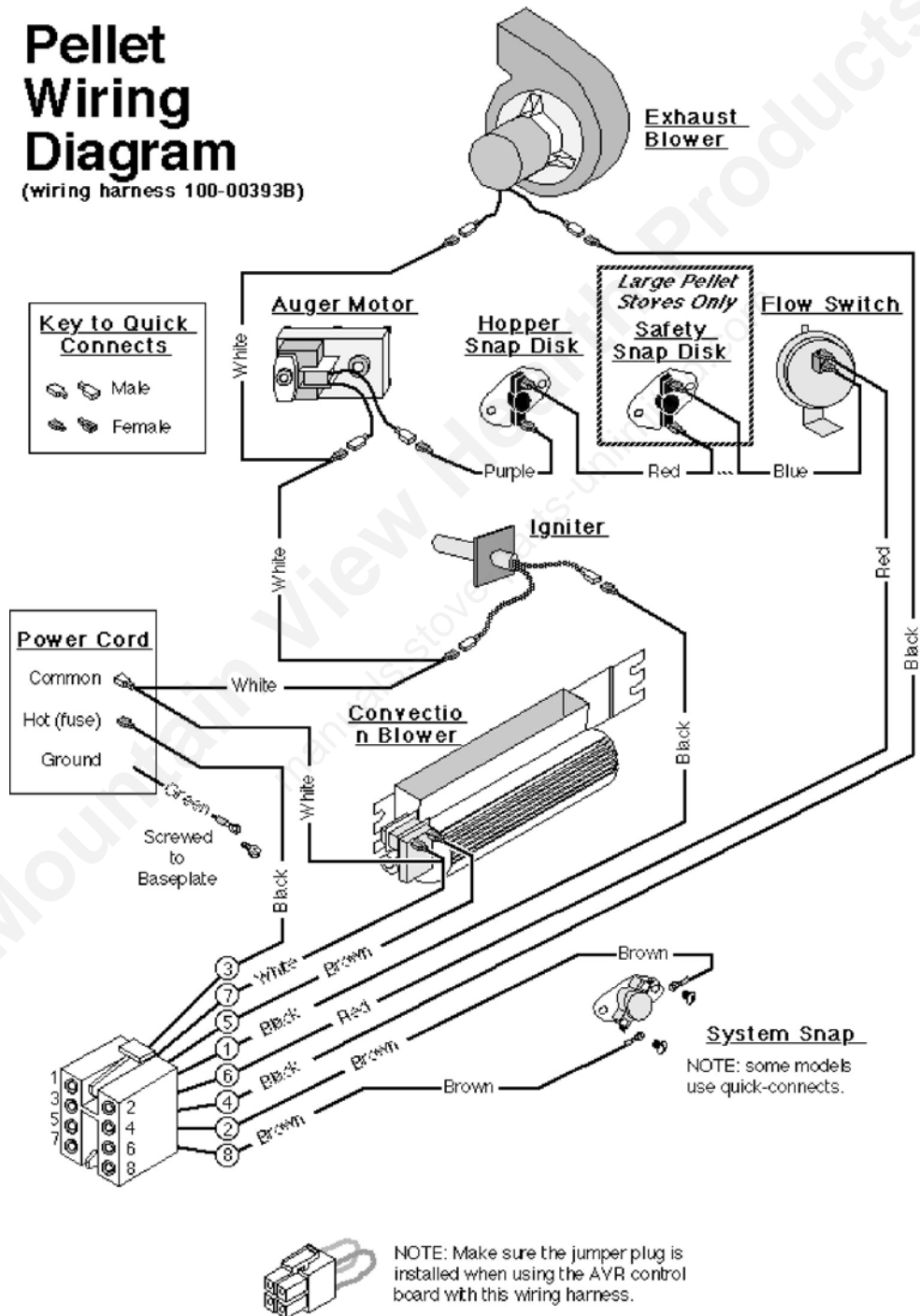

Control Board Operation

The Two Modes of Operation:

Manual

Manual mode requires the user to turn the heater on and off manually.

Auto (requires a thermostat)

Auto mode allows you to use a thermostat to control room temperature. The stove automatically turns on when the temperature drops below the thermostat setting. Once the stove reaches operating temperature, the stove then runs at the heat output setting selected.

Switching

Modes While in Operation

Whenever the stove is switched from one mode to another while in operation, the stove will enter the "start-up" sequence for a minimum of 20 minutes.

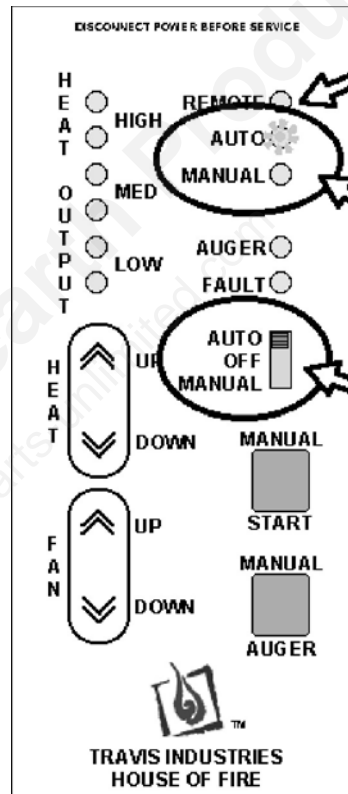

NOTE: If using a modulating remote, this light will come on to indicate the remote is controlling the heater.

These indicator lights are used to determine which mode you are in.

Use the mode switch to determine the mode.

Control Board Operation

Manual Mode

Manual mode requires the user to turn the heater on and off manually.

To Start

Press the "Manual Start" button. That's it. The stove automatically goes to a medium burn rate and high fan while the igniter starts the fire burning within 10 minutes. During this period the lowest "HEAT OUTPUT" light will flash. If the stove does not start in 30 minutes, the stove turns off.

Once up to temperature, the stove will then run at the heat output setting selected on the control panel (see "To Adjust the Heat" below).

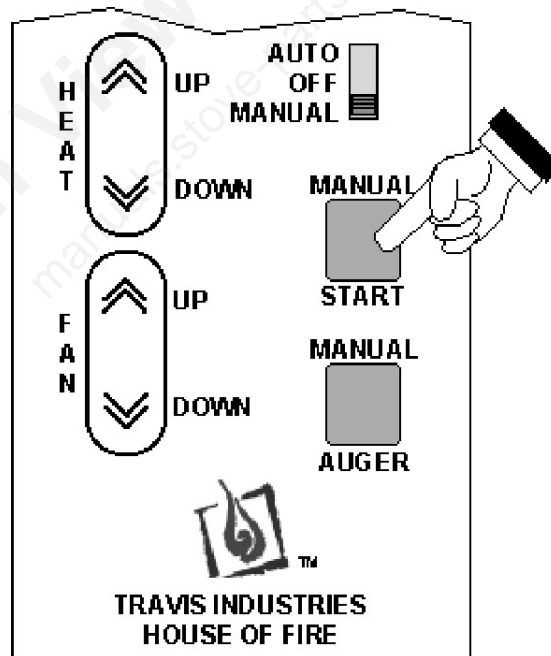

Control Board Operation

To Shut Down

Move the mode switch to "OFF". The exhaust blower will still run until the heater cools down.

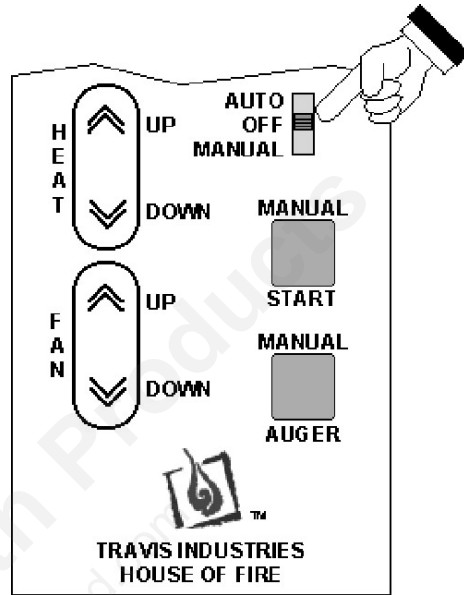

To Adjust the Heat

Press the "Heat" buttons to adjust the heat output.

NOTE: During start-up you may adjust the heat setting. This heat setting will take affect once the start-up sequence is complete.

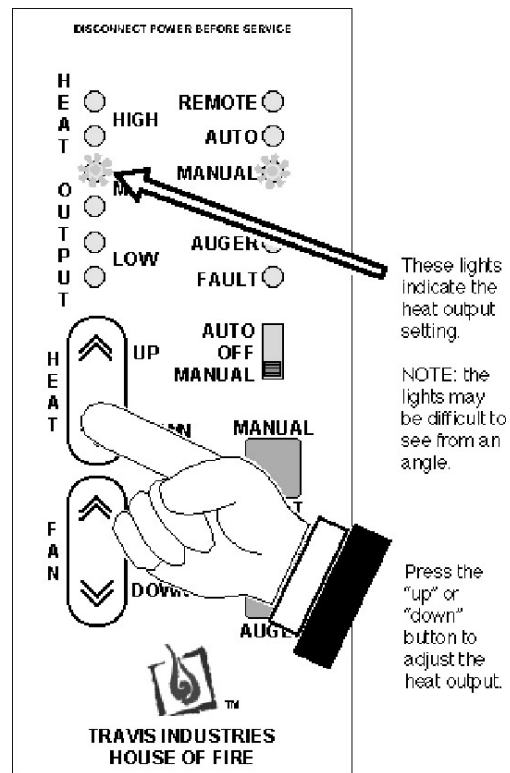

Control Board Operation

Auto Mode

Auto mode allows you to use a thermostat to control room temperature. The stove automatically turns on when the temperature drops below the thermostat setting. Once the stove reaches operating temperature, the stove then runs at the heat output setting selected.

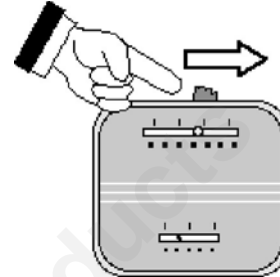

To Adjust Room Temperature (or Start the Stove)

Move the thermostat to the heat setting desired. If the room is cooler than the setting, the stove will go through the start-up sequence for approximately 10 minutes. During this period the lowest "HEAT OUTPUT" light will flash. Once up to temperature, the stove will then run at the heat output setting selected on the control panel. If the room is too hot, move the thermostat to a lesser setting.

To Adjust the Heat

Press the "Heat" buttons to adjust the heat output.

HINT:

If you find that the stove turns on and off repeatedly, you may wish to turn the heat output to a lesser setting. The lower setting will provide a more consistent heat output over time, eliminating the need for the thermostat to repeatedly turn the stove off.

NOTE:

If the thermostat calls for heat while the stove is still cooling down, the stove will go through the start-up sequence (for a minimum of 20 minutes).

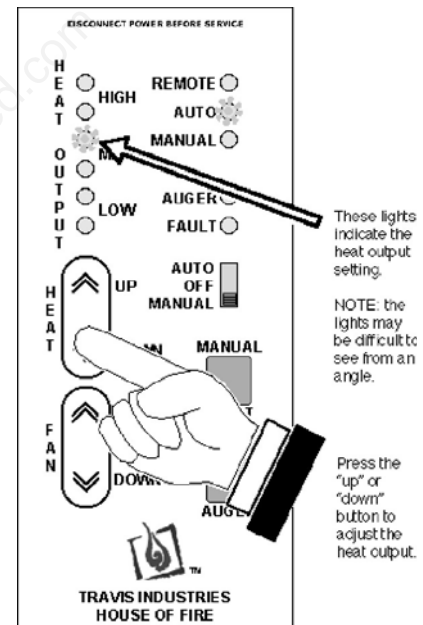

Control Board Operation

To Shut Down

Move the mode switch to "OFF". The exhaust blower will still run until the heater cools down.

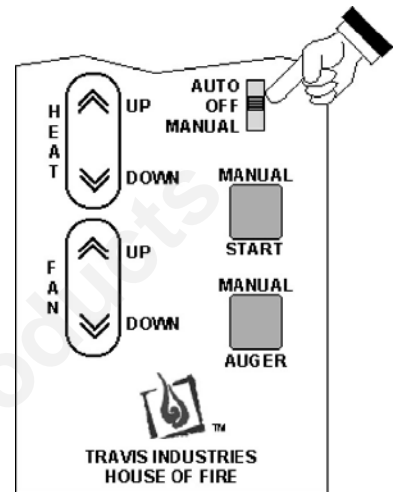

Adjusting the Fan Speed

NOTE: When you press the Fan speed buttons the "Heat Output" lights will indicate fan speed (not "Heat Output"). After a few seconds the "Heat Output" lights will go back to displaying the heat output setting.

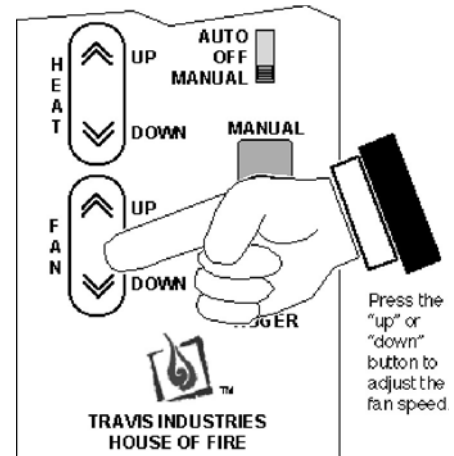

Control Board Operation

"FAULT" Light

This light comes on when an error occurs:

- The stove runs out of pellets
- During initial start-up (for a split second) or for improper electrical frequency
- A start-up sequence that does not result in the heater coming up to temperature
- To reset the fault light, turn the mode switch to off and re-start the stove.

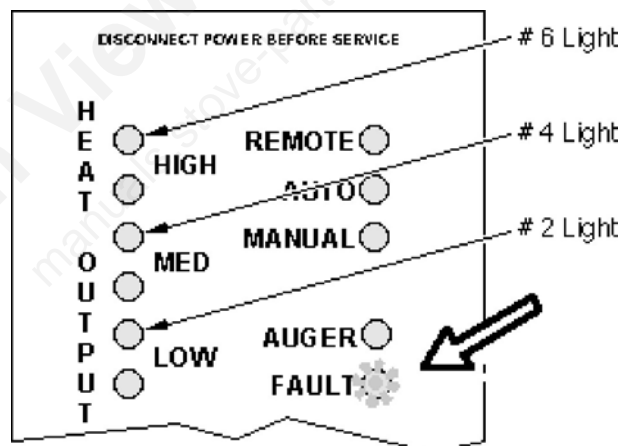

Troubleshooting Pellet Appliances

Troubleshooting Pellet Appliances

- **Mode Sequence Ask What?**
 - **Unplug To Reset Board**
 - **Move Through Modes of Operation**
 - **Self Diagnosis**
- Keep the operation sequence in mind. Ask what should be working in each mode and what should not.
 - Before troubleshooting any pellet appliance always **UNPLUG** and re-plug **THE APPLIANCE** to reset the control board, (If the appliance was turned off before it finished the cool down mode it will start there instead of the start-up mode).
 - Run through the modes and observe what is working or not working.
- Begin with what is not working before you move to the next mode.
 - Each time the pellet system is turned on it runs a quick self-diagnosis, (you will see the fault light come on and then go off).
 - If, during this diagnosis, it senses any problem with the convection blower or circuit, the exhaust blower will immediately come on, even through the ON/OFF switch is off.
 - This automatically tells you there is a convection circuit problem that must be corrected.

Required Testing Equipment

- **Multimeter**



- **Power Test Cord Kit & Jumper Wire**



- **Outlet Analyzer**

- **Volt Stick**



Pellet Stove Component Testing

Outlet Analyzer

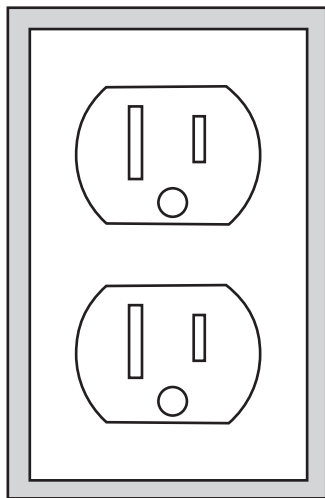

**110 Volt
Outlet**



- Test the power outlet to verify proper polarity and proper grounding.

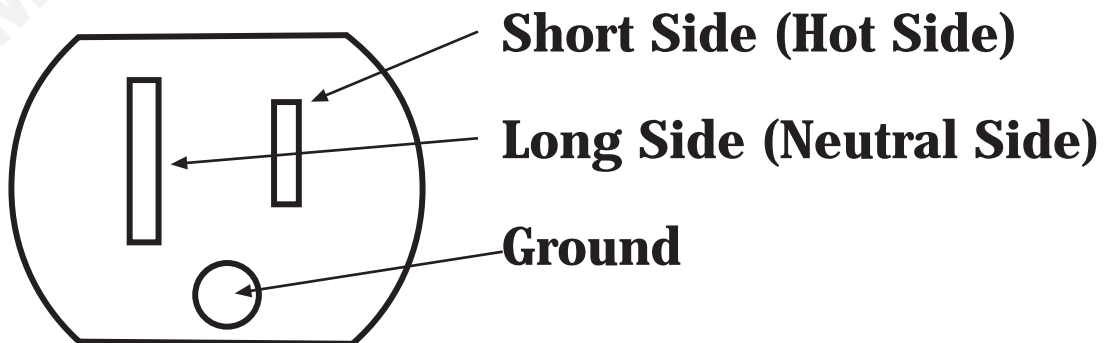

Power Cord Testing Pellet Components

- Connect power cord to component, then plug the power cord into a known, working power outlet.



- Convection Blower



Small Pellet Stoves



Large Pellet Stoves

- Exhaust Blower

Small Pellet Stoves

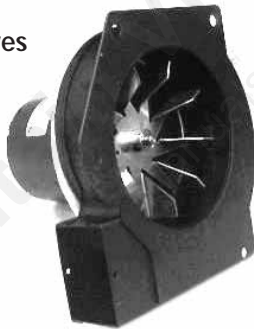

Large Pellet Stoves

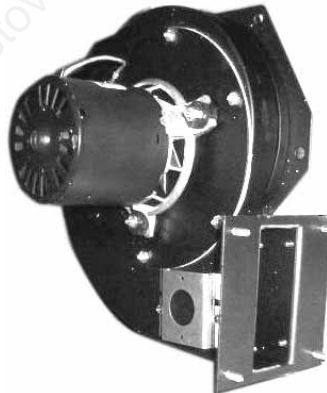

- Igniter

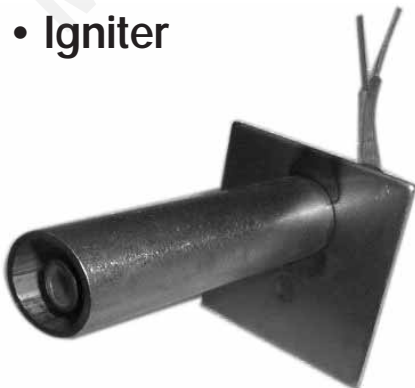

- Auger Motor

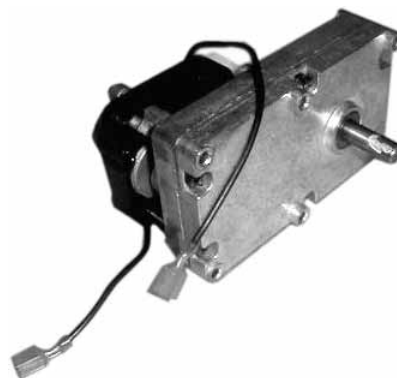

Power Cord Testing

Test Point
① - ①
② - ②
③ - ③
④ - ④

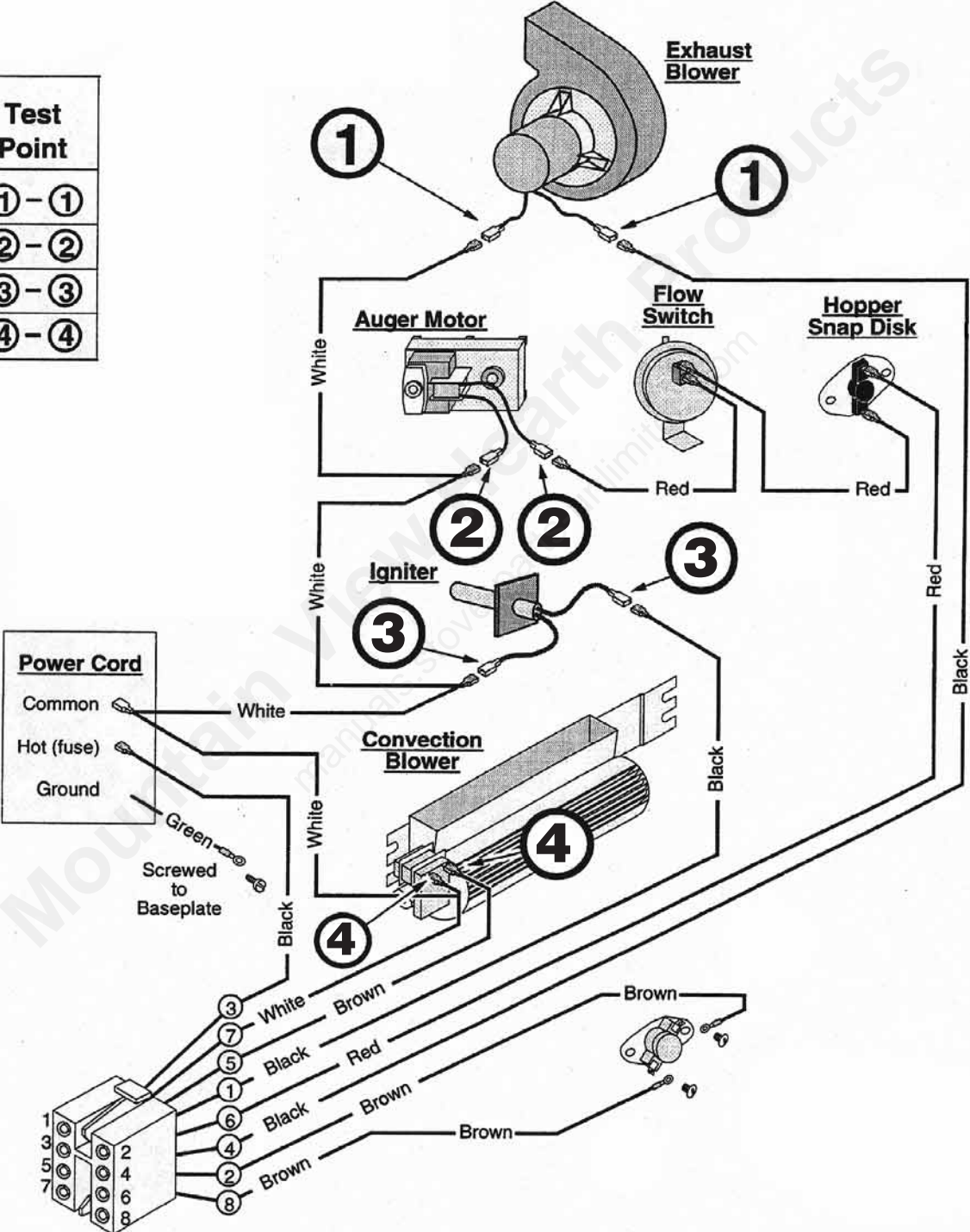

Continuity Testing Pellet Components

- **TURN OFF ALL POWER**
- Disconnect at least on side of the device being tested to avoid the “Back Door Sneak!”



- **FLOW SWITCH (N. O.)**
Normally Open



- **AUGER MOTOR**

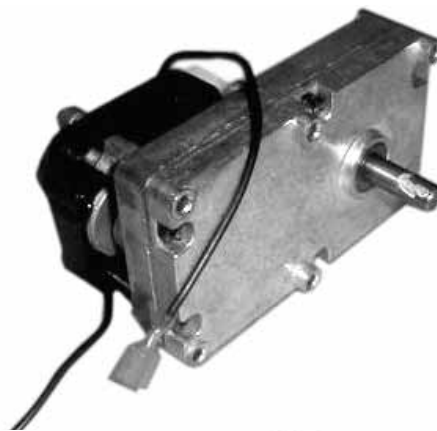

- **200° SNAP DISKS**



Convection & Hopper Snap Disk (N. C.)
Normally Closed



120° System Snap Disk (N. O.)
Normally Open

Continuity Testing Pellet Components



• CONVECTION BLOWER

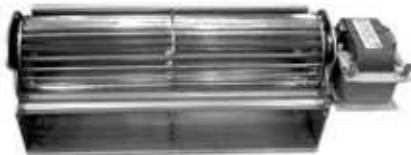

Small Pellet Stoves



Large Pellet Stoves

• EXHAUST BLOWER

Small Pellet Stoves

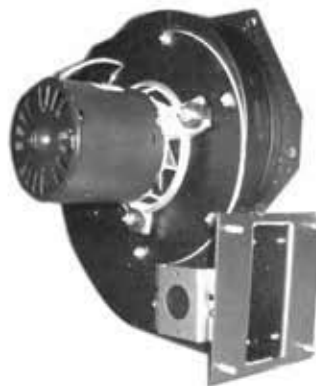
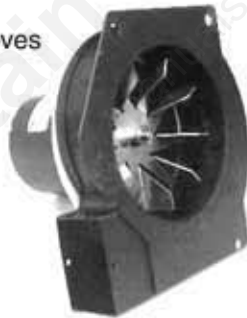

Large Pellet Stoves

• IGNITER



NOTE: Do not continuity test igniter in the audible "BEEP" meter mode, use the (ohms) mode.

The range for our two igniters is as follows:

200 watt element (plain white wires) $72\Omega +10/-5$

250 watt element (red striped white wires) $57\Omega +10/-5$

Pellet Stove Continuity Component Testing

Component	Condition	
	Good	Bad - Replace
Auger Motor	Continuity Across Wires	No Continuity Across Wires
Flow Switch	(With Vacuum) Continuity Across Switch Contacts	No Continuity Across Switch Contacts
Igniter	Continuity Across Wires	No Continuity Across Wires
System Disk: Porcelain Snap Disk F- 120° F (N. O.)	<u>Ambient Temperature</u> No Continuity <u>Temperature Rise</u> Continuity	No Continuity With Temperature Rise
Safety Hopper Disk: Snap Disk L-200° F (N. C.)	<u>Ambient Temperature</u> Continuity <u>Temperature Rise</u> No Continuity	Continuity With Temperature Rise. No Continuity When Cold or When Hot.
Convection Chamber Disk (Large Appliances) L-200° F (N. C.)	<u>Ambient Temperature</u> Continuity <u>Temperature Rise</u> No Continuity	Continuity With Temperature Rise. No Continuity When Cold or When Hot.
Convection Blower	Continuity Across Wires	No Continuity
Exhaust Blower	Continuity Across Wires	No Continuity

- Always Have “POWER OFF” When Conducting a Continuity Test
- Always Isolate the Component By Disconnecting at Least One Side of the Circuit

Molex Connector # System

- The Molex connector is numbered, but hard to read so...
- With Molex connector turned so the cross member **(A)** is at the top-
 - The left side is odd #
 - The right side is even #

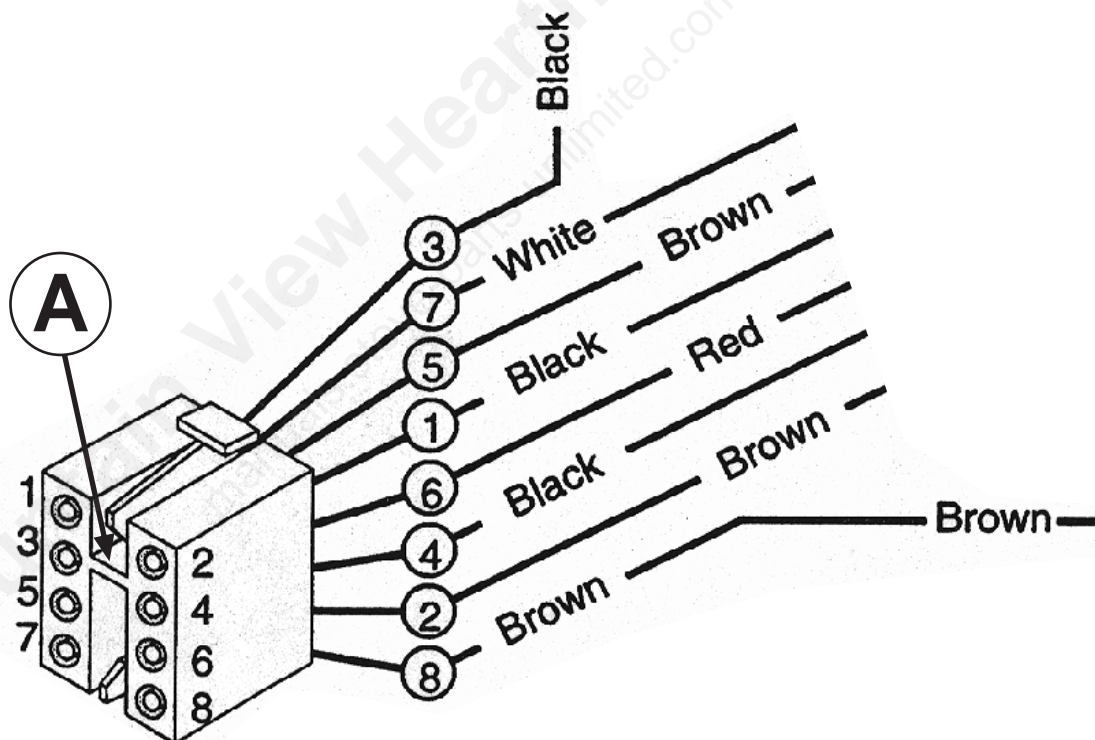

- The left side is odd #
- The right side is even #

Continuity Testing Molex Connector & Wires

MOLEX END	TEST TO	WIRE END	CONTINUITY	NO CONTINUITY
1	↔	1	GOOD	DEFECTIVE
2	↔	2	GOOD	DEFECTIVE
3	↔	3	GOOD	DEFECTIVE
4	↔	4	GOOD	DEFECTIVE
5	↔	5	GOOD	DEFECTIVE
6	↔	6	GOOD	DEFECTIVE
7	↔	7	GOOD	DEFECTIVE
8	↔	8	GOOD	DEFECTIVE

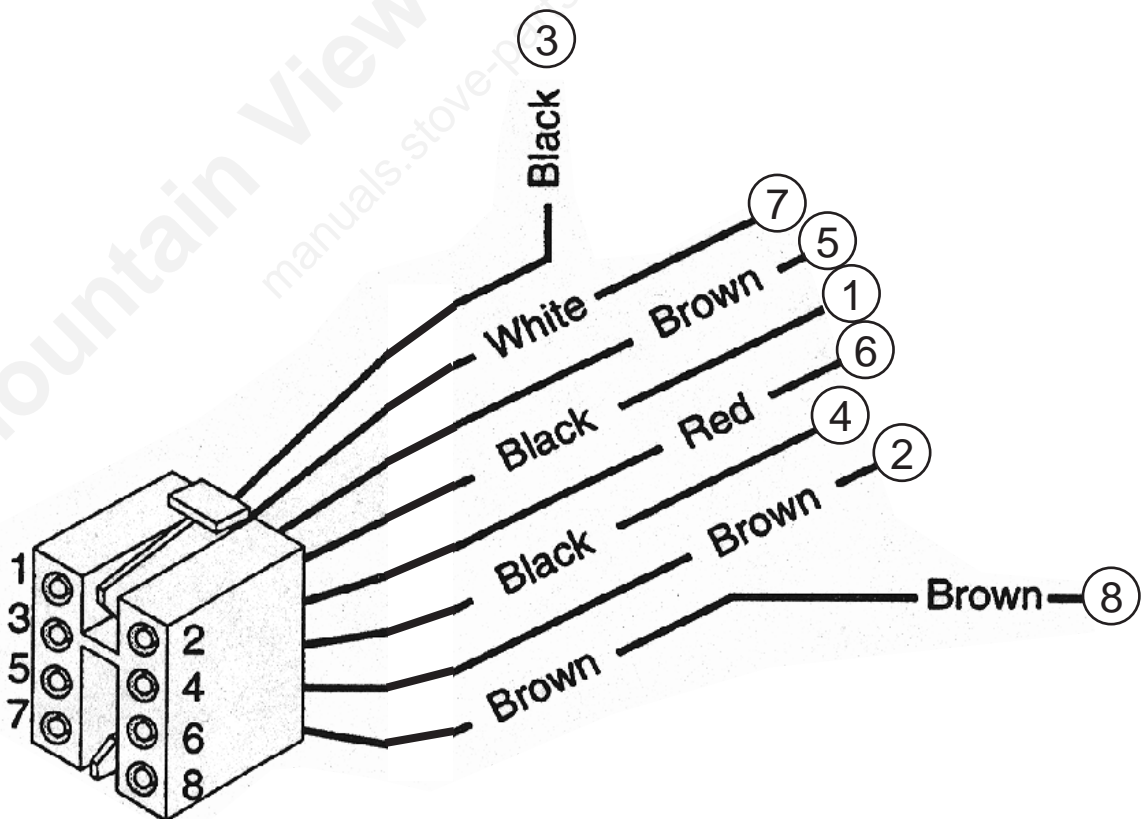

New Pellet Board Auger Timing

Auger ON Time 2.5 Sec.

LOW	First Light	OFF Time	10.7 Sec.
	Second Light	OFF Time	7.5 Sec.
	Third Light	OFF Time	4.6 Sec.
	Fourth Light	OFF Time	3.8 Sec.
	Fifth Light	OFF Time	2.9 Sec.
	Sixth Light	OFF Time	2.2 Sec.

Combustion Fan Volts Per Setting - Small Stoves

LIGHT	1	LOW	68 AVC.
	2		75 AVC..
	3		85 AVC.
	4		95 AVC.
	5		105 AVC..
	6	HIGH	115 AVC.

Combustion Fan Volts Per Setting - Large Stoves

LIGHT	1	LOW	85 AVC.
	2		95 AVC..
	3		105 AVC.
	4		115 AVC.
	5		115 AVC..
	6	HIGH	115 AVC.

New Board Convection Fan Levels

LIGHT	1	LOW	70 AVC.
	2		85 AVC..
	3		90 AVC.
	4		100 AVC.
	5		105 AVC..
	6	HIGH	115 AVC.

Troubleshooting Burn Problems

Burn Characteristics	1
Burn Related Problem Matrix	2
Pellet Fuel	3

Mountain View Hearth Products
manuals.stove-parts-unlimited.com

Troubleshooting Burn Characteristics

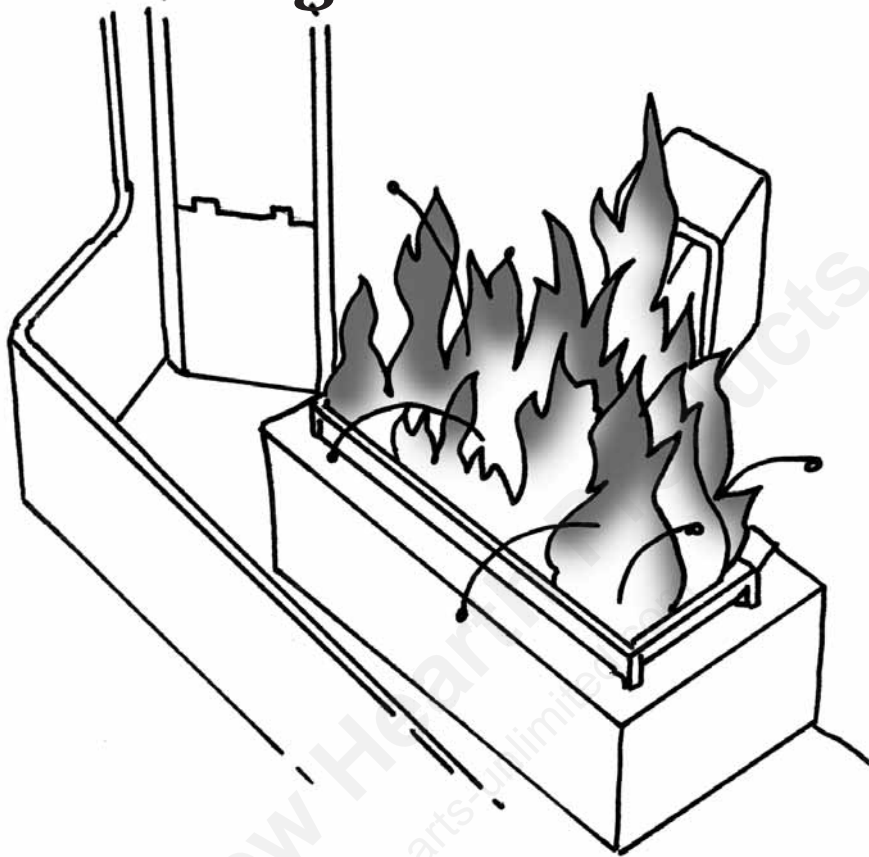

Burn Characteristics

NORMAL

- Bright orange flame
- Slight “Popcorning” effect of pellets
- Ash blowing out of burnpot
- Occasional ember blowing out of burn pot

ABNORMAL

- Pellet piling up
- Excessive “Popcorning” effect of pellets
- Unburnt or partially burnt pellets blowing out of burnpot
- Excessive clinker buildup in burnpot
- Soot deposits

Pellet Appliance Operation Problem Check List

Burn Related Problems	CHECK							
	Door Gasketing Air Leak	Glass Gasketing Air Leak	Poor Pellets	Dirty Burnpot	Dirty Exhaust System	Restrictor Needs More Restriction	Restrictor Needs Less Restriction	Air Wash Slots Blocked
Excessive Clinker Buildup	X	X	X		X		X	
Excessive Ash Buildup	X	X	X	X	X		X	
Pellets Buildup	X	X		X	X	X		
Dirty Glass	X	X		X	X		X	X

No Heat	CHECK							
	Operator Error	Client Expectations	Door Gasketing Air Leak	Glass Gasketing Air Leak	Poor Pellets	Dirty Burnpot	Dirty Exhaust System	Dirty Heat Exchanger Tubes
	X	X	X	X	X	X	X	X

Auger Jam	CHECK					
	Lack of Proper Maintenance (Fine Buildup)	Foreign Objects	Poor Quality Pellets (Fine Buildup)	Defective Bearing	Defective Auger Motor	

Mountain View Hearth Products
manuals.stove-parts-unlimited.com

Thermostats & Remotes

Appliance Does Not Work On Thermostat Setting	1
Testing Thermostats	2
Appliance Does Not Work On Remote Function	3
Wall Thermostat	4-5
Remote Control	6-8
Modulating Remote	9-15

Mountain View Hearth Products
manuals.stove-parts-unlimited.com

Pellet Fuel

Pellet Fuel

- **Wood**
- **Quality Premium Grade**

- Travis pellet appliances are designed to burn wood pellets.
- The quality of the pellet fuel will dictate how well the pellet appliance will perform.
- Pellet fuel with lots of fines and high ash content will produce maintenance and burn problems
- Therefore, we recommend that only **premium** grade pellets be used (See Chart)

(PFI) Pellet Fuel Institute Fuel Standards

<u>CRITERIA</u>	<u>PREMIUM GRADE</u>	<u>STANDARD GRADE</u>
1. Bulk density/cu.ft.	Not less than 40 lbs.	Not less than 40 lbs.
2. Dimensions	Diameter 1/4" to 5/16"	Diameter 1/4" to 5/16"
3. Fines	Not more than .5% by weight shall pass 1/8" screen	Not more than .5% by weight shall pass 1/8" screen
4. Sodium (salts)	Less than 300 parts per million	Less than 300 parts per million
5. Inorganic ash	Less than 1%	Less than 3%
6. Length	Maximum 1/1/2"	Maximum 1/1/2"

Pellet Appliance Works on Manual But Not on Automatic (Thermostat)

CHECK	POSSIBLE CAUSE	CORRECTIVE ACTION
Control Board	<ul style="list-style-type: none"> • Switch not in auto position • Thermostat wires not connected 	<ul style="list-style-type: none"> • Move to auto position • Connect to control board
Thermostat	<ul style="list-style-type: none"> • Improper setting • Improper location picking up heat from some other device • Defective thermostat • Defective wires 	<ul style="list-style-type: none"> • Set to proper setting • Remove heat source or move thermostat • Check and replace as necessary • Check and replace as necessary
Control Board	<ul style="list-style-type: none"> • If all of the above is good the control board is defective 	<ul style="list-style-type: none"> • Replace control board

Testing the Thermostat Circuit

- Make sure the unit control board switch is in the automatic mode.

Jumper Wire Test. - Jumper turns on fire. - Replace thermostat

Jumper wire does not turn on fire.

- Bad wire (Replace wire)

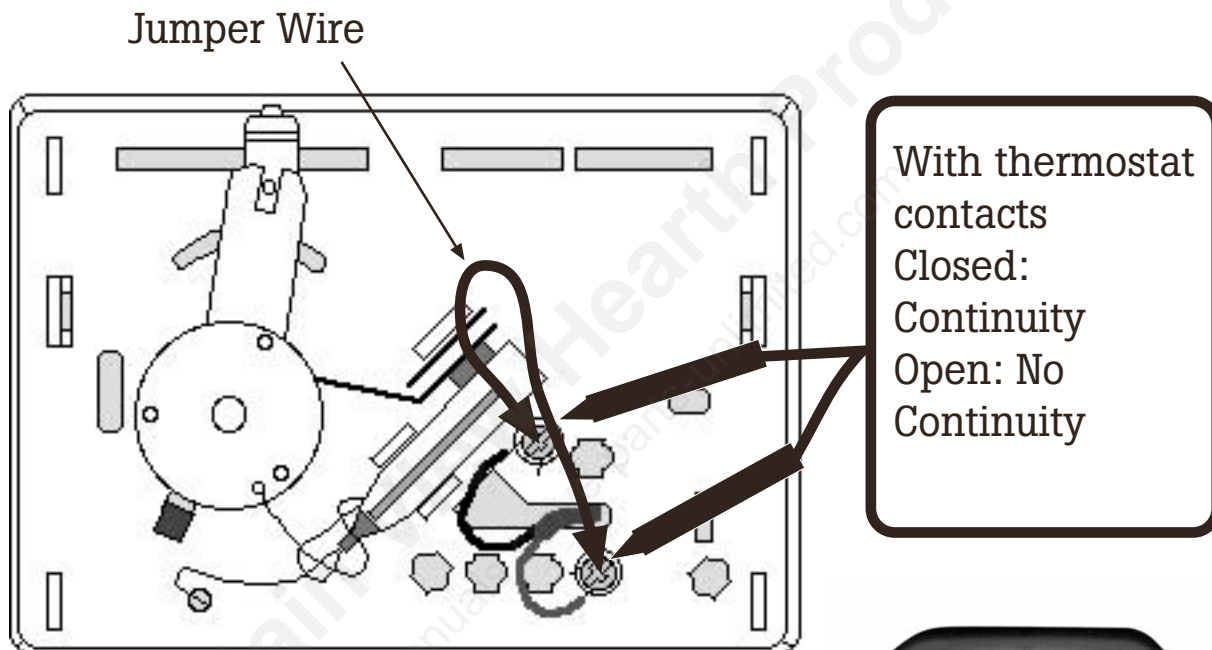

Thermostat Wire Test Continuity Test

- Disconnect the wires from the thermostat
- Close the thermostat contacts

Continuity - Good Thermostat
- Defective Wires

No Continuity - Bad Thermostat
- Replace Thermostat



Pellet Appliance Works on Manual But Not in Remote Mode (Remote Control)

CHECK	POSSIBLE CAUSE	CORRECTIVE ACTION
Operator	<ul style="list-style-type: none"> • Not understanding remote control operation • Unrealistic expectations 	<ul style="list-style-type: none"> • Educate • Educate
Remote	<ul style="list-style-type: none"> • Dead batteries • Not plugged into control board • DIP switches (frequency) do not match • Remote sender in position to pickup heat from some other source • Defective sender or receiver 	<ul style="list-style-type: none"> • Replace • Plug in • Match sender and receiver DIP switches • Relocate remote control (sender) • Test and replace as necessary
Control Board	<ul style="list-style-type: none"> • If all of the above is good the control board is defective 	<ul style="list-style-type: none"> • Replace control board

Pellet Wall Thermostat

COMPATIBILITY

- All Travis Gas Stoves & Inserts
- Newport Pellet Stoves & Inserts
- Pioneer Pellet Stoves & Inserts
- Astoria Pellet Stoves & Inserts
- Yankee Pellet Stoves & Inserts

ITEMS NEEDED FOR ASSEMBLY

- Standard Screwdriver
- Additional tools may be required for laying the thermostat wire
- You may need additional tools to access the on/off switch on certain gas heaters - refer to the instructions in the owner's manual.

PACKING LIST

- Thermostat
- Thermostat wire (20' long)
- 2 Screws (for attaching the thermostat to wall)

INSTALLATION INSTRUCTIONS

! This kit must be installed by a qualified technician.

! Do not connect 110 VAC to the gas control valve or on/off switch on gas heaters or the thermostat posts on pellet heaters.

Pellet Heater Installation

Attach the thermostat wire to the circuit board.

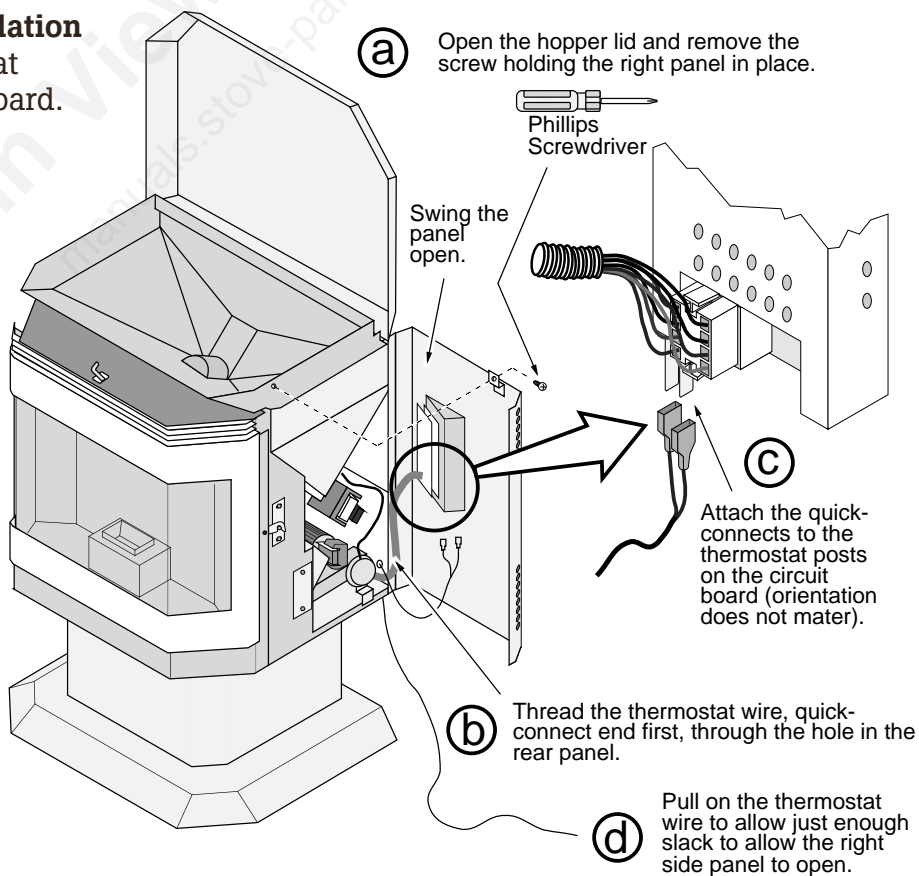

Pellet Wall Thermostat

Thermostat Placement and Installation

1. Determine a location for the thermostat that is within range of the 20' length of thermostat wire. It should be centralized in the room and away from the heater. The wire may be routed externally on the wall or behind the wall (preferred). Run the thermostat wire to this location. Use nylon ties, if necessary to keep the wire from contacting any hot portions of the heater.

2. Follow the directions below to attach the thermostat and thermostat wires.

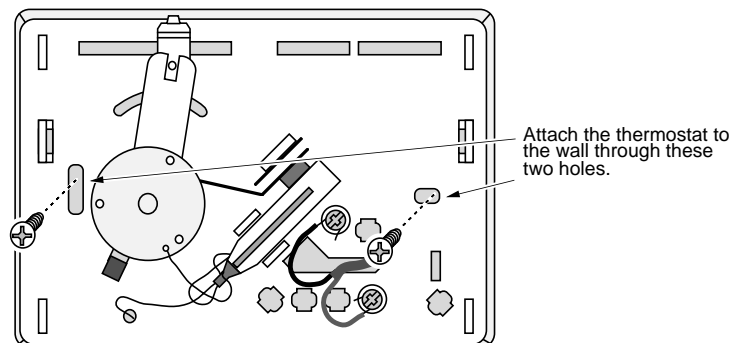
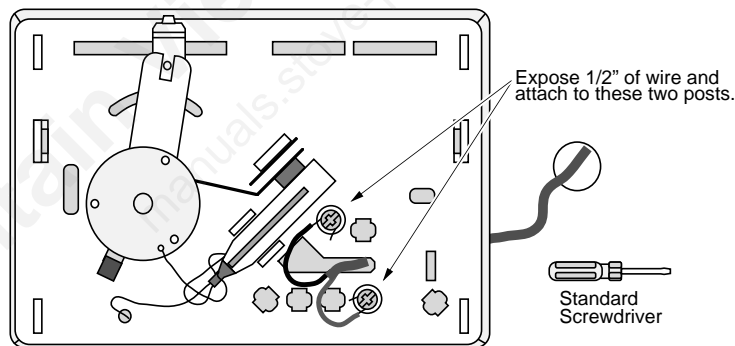
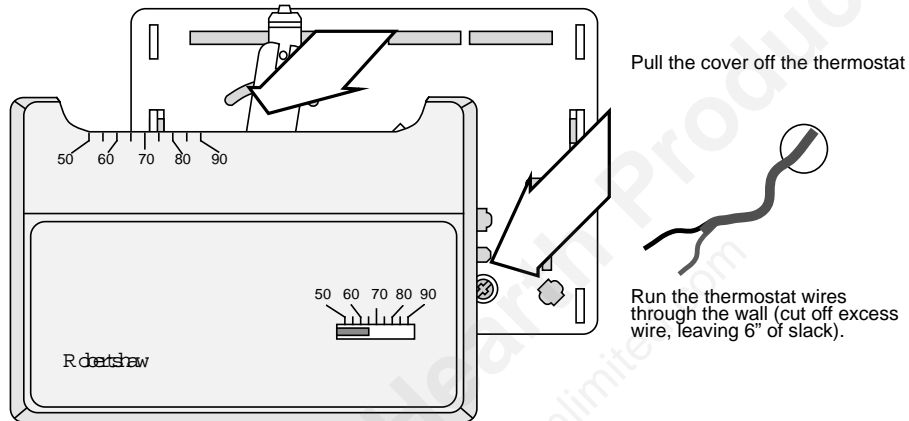

Pellet Remote Control

CHECK CONDITION OF SHIPMENT

Upon receipt of this kit, check the condition of the packaging. Damage to the package should be noted on the carrier's freight receipt. Any damage claims as a result of shipping must be handled through the shipper. Travis Industries will provide assistance in resolving shipping claims or replacing items not included in the package. Please report any missing items immediately.

COMPATIBILITY

• All Travis Gas Stoves & Inserts • Newport (Avanti) Pellet Stoves & Inserts • Pioneer (Heritage Bay) Pellet Stoves & Inserts

ITEMS NEEDED FOR ASSEMBLY

You may need tools for to access the on/off switch on gas heaters - refer to the instructions below and in the owner's manual.

PACKING LIST

• Receiver • Transmitter • Receiver Hanger • Pellet Stove Connector Wires • Gas Stove Connector Wires • 3 AAA Batteries

FCC REQUIREMENTS

Warning: Changes or modifications to this unit not expressly approved by the party responsible for compliance could void the user's authority to operate the equipment. This equipment has been tested and found to comply with the limits for a Class B digital device, pursuant to Part 15 of the FCC Rules. These limits are designed to provide reasonable protection against harmful interference in a residential installation. This equipment generates, uses, and can radiate radio frequency energy and, if not installed and used in accordance with the instructions, may cause harmful interference to radio communications. However, there is no guarantee that interference will not occur in a particular installation. If this equipment does cause harmful interference to radio or television reception, which can be determined by turning the equipment off and on, the user is encouraged to try to correct the interference by one or more of the following measures:

- Reorient or relocate the receiver.
- Increase the separation between the equipment and receiver.
- Connect the equipment into an outlet on a circuit different from that to which the receiver is connected.
- Consult the dealer or an experienced radio TV technician for help.

CANADIAN EQUIPMENT REQUIREMENTS

This digital apparatus does not exceed the (Class A/Class B) limits for radio noise emissions from digital apparatus set out in the Radio Interference Regulations of the Canadian Department of Communications. Le present appareil numerique n'emmet pas de bruits radioelectricques dépassant les limites applicables aux appareils numeriques (de la class A/de la class B) prescrites dans le Reglement sur le brouillage radioelectrique edicte par le ministere des Communications du Canada.

This device complies with RSS-210 of Industry and Science Canada. Operation is subject to the following two conditions: (1) this device may not cause interference, and (2) this device must accept any interference, including interference that may cause undesired operation of the device.

INSTALLATION INSTRUCTIONS

- ! Shut off power to the appliance and allow it to cool prior to installation.
 - ! This kit must be installed by a qualified technician.
 - ! All 110 VAC wiring must be done by a qualified electrician and shall be in compliance with local codes and the National Electric Code ANSI/NFPA No. 70 (in the United States), or with the current CSA C22.1 Canadian Electric Code (in Canada).
 - ! Do not connect 110 VAC to the gas control valve or on/off switch on gas heaters or the thermostat posts on pellet heaters.
- 1 Remove the cover from the back of the transmitter and receiver. Slide the code switches to a random position on the receiver. Then position the switches on the transmitter to match the dip switch positions on the receiver. Prior to replacing the cover, place three AAA batteries inside the transmitter.

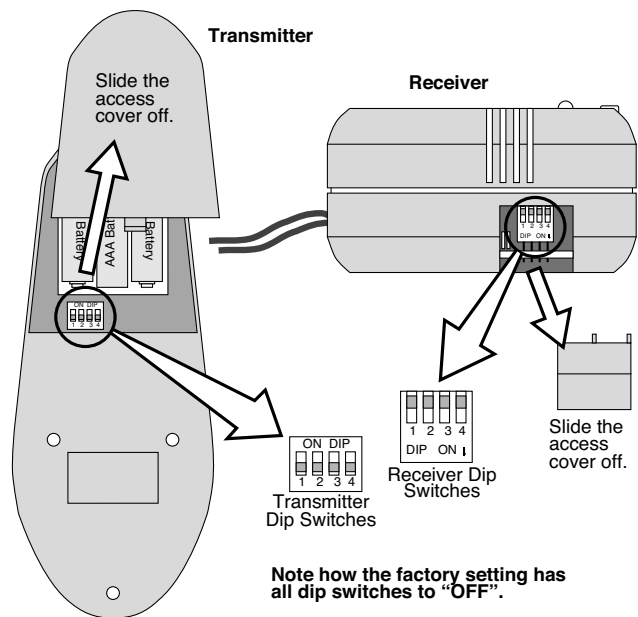

Pellet Remote Control

Pellet Stove Installation

Place the receiver holder on the back of the heater and route the receiver wires to the on/off switch (see the illustration to the right). Connect the receiver power cord to a 110 VAC outlet.

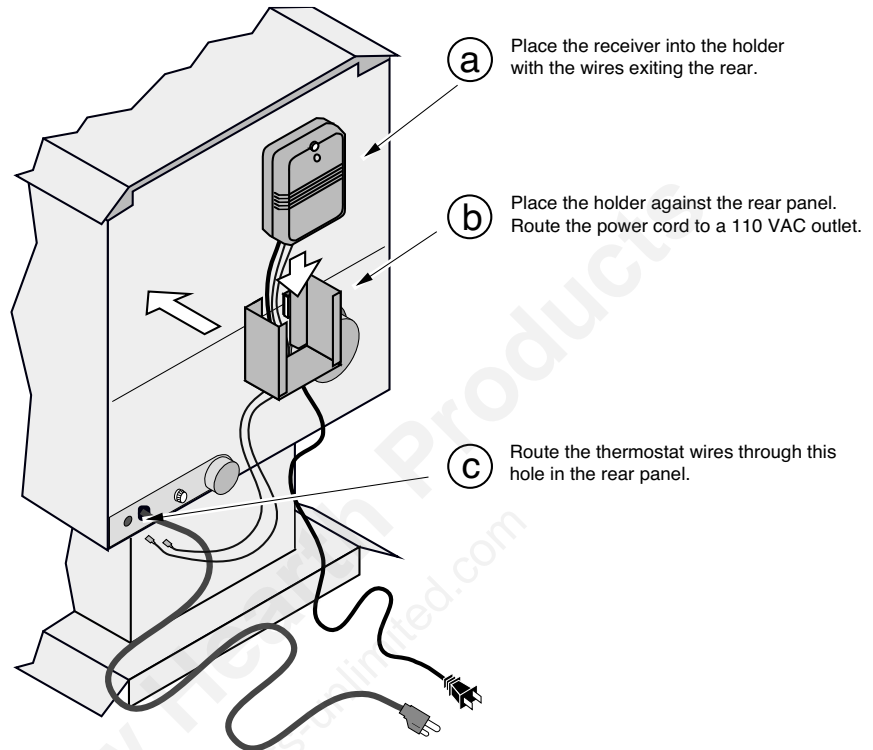

Attach the pellet stove connector wires to the ends of the receiver wires. Then attach the connector wires to the back of the circuit board (see the illustration to the right).

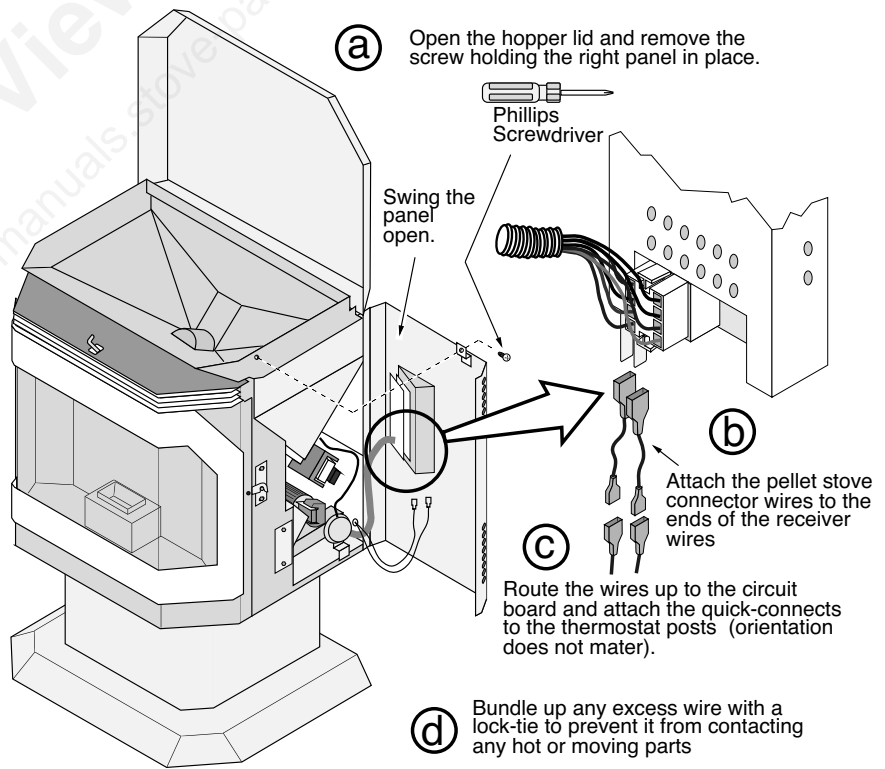

Pellet Remote Control

NOTE: The pilot flame must be lit, the gas control valve turned to "ON", and the on/off switch turned to "OFF" for the remote to work correctly.

NOTE: This kit must be installed by a qualified technician.

MANUAL MODE:

TO SET TO MANUAL:
Use the arrow keys to adjust the target temperature to 90°.

TO TURN ON AND OFF:
Use this key to toggle the heater on and off. The display will indicate the status.

NOTE:
If the room exceeds 90°, the heater will shut off.

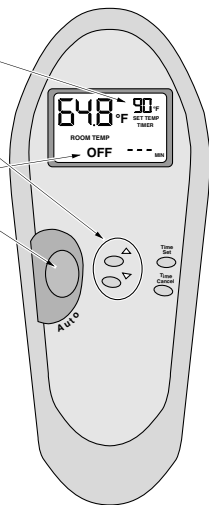

THERMOSTAT MODE:

TO SET TO THERMOSTAT MODE:
Use this key to toggle the thermostat mode on. The display will indicate "ON" in the lower left.

HINT:
If your heater turns on and off frequently, adjust the flame height (burn rate on pellet heaters) down slightly for a more consistent heat output.

TO ADJUST TARGET TEMPERATURE:
Use the arrow keys to adjust the target temperature to the desired level.

The heater will turn on and off to keep the room temperature near the target temperature.

IMPORTANT OPERATIONAL NOTE:
The thermostat has a built-in time delay to keep the heater from constantly turning on and off. This means the target temperature may be slightly higher (2° or 3°) than the room temperature – do not adjust the target temperature – the heater will turn on in a few minutes.

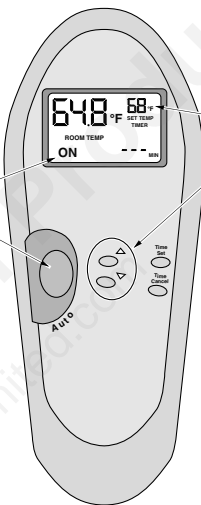

TIMED MODE:

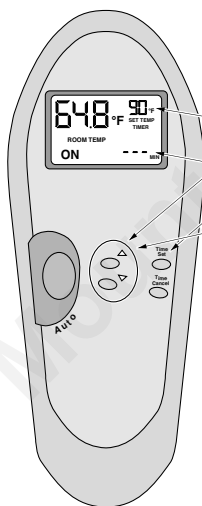

TO SET TO TIMED OPERATION:

- Use the arrow keys to adjust the target temperature to 90°.
- Press the "Time Set" button - the " - - - " will start to flash.
- Use the arrow keys to set the number of minutes you would like the heater to stay on.

The heater will turn on and stay running for the number of minutes displayed.

NOTE:
If the room exceeds 90°, the heater will shut off.

REPLACING THE BATTERIES:

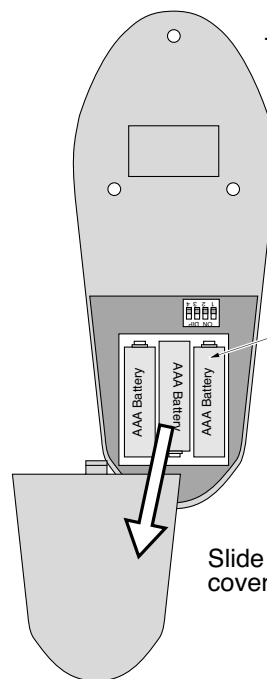

Transmitter

Use "AAA" batteries with the remote

Slide the access cover off.

POWER OUTAGES:

If a power outage occurs, the receiver will turn the heater off. Once power is restored, the remote will turn the heater on (if the remote calls for heat) within 30 minutes. If you wish to over-ride the remote and turn the heater on (gas stoves only), turn the on/off switch on the gas heater to "ON".

Pellet Modulating Remote

COMPATIBILITY

- Avalon Newport Stove & Insert
- Avalon Astoria Stove & Insert
- Lopi Pioneer Stove & Insert
- Lopi Yankee Stove & Insert

ITEMS NEEDED FOR ASSEMBLY

- Three AAA Batteries

PACKING LIST

- Remote Receiver • Remote Control • Modulating Regulator • Torx T-20 Ball-End "L" Wrench
- Stove Receiver Mounting Bracket • Fireplace Receiver Heat Shield

FCC EQUIPMENT REQUIREMENTS

WARNING: Changes or modifications to this unit not expressly approved by the party responsible for compliance could void the user's authority to operate the equipment.

NOTE: This equipment has been tested and found to comply with the limits for a Class B digital device, pursuant to Part 15 of the FCC Rules. These limits are designed to provide reasonable protection against harmful interference in a residential installation. This equipment generates, uses, and can radiate radio frequency energy and, if not installed and used in accordance with the instructions, may cause harmful interference to radio communications. However, there is no guarantee that interference will not occur in a particular installation. If this equipment does cause harmful interference to radio or television reception, which can be determined by turning the equipment off and on, the user is encouraged to try to correct the interference by one or more of the following measures:

- Reorient or relocate the receiver.
- Increase the separation between the equipment and receiver.
- Connect the equipment into an outlet on a circuit different from that to which the receiver is connected.
- Consult the dealer or an experienced radio TV technician for help.

INSTALLATION WARNINGS

! Place the remote receiver in the location detailed in these instructions. Placing the receiver in other locations may cause the receiver to become too hot and degrade.

! All 110 AC wiring must be done by a qualified electrician and shall be in compliance with local codes and the National Electric Code ANSW/NFPA no. 70 (in the United States).

! This kit must be installed by a qualified technician.

! Do not connect 110 VAC to the gas control valve or on/off switch on gas heaters or the thermostat posts on pellet heaters.

! The remote control is carefully engineered and **MUST** be installed only as specified. It is tested safe when installed in accordance with this installation manual. If you modify it or any of its components, you may possibly cause a fire hazard. It is your responsibility to read all instructions before starting installation and to follow these instructions carefully during installation.

! Disconnect the power (turn off the household breaker) and shut off the gas supply to the heater before installing the remote control.

Pellet Modulating Remote

INSTALLATION INSTRUCTIONS

- 1 Remove the cover from the back of the transmitter. Slide the code switches to a random position on the receiver. Then position the switches on the transmitter to match the dip switch positions on the receiver. Prior to replacing the cover, place three AAA batteries inside the transmitter.

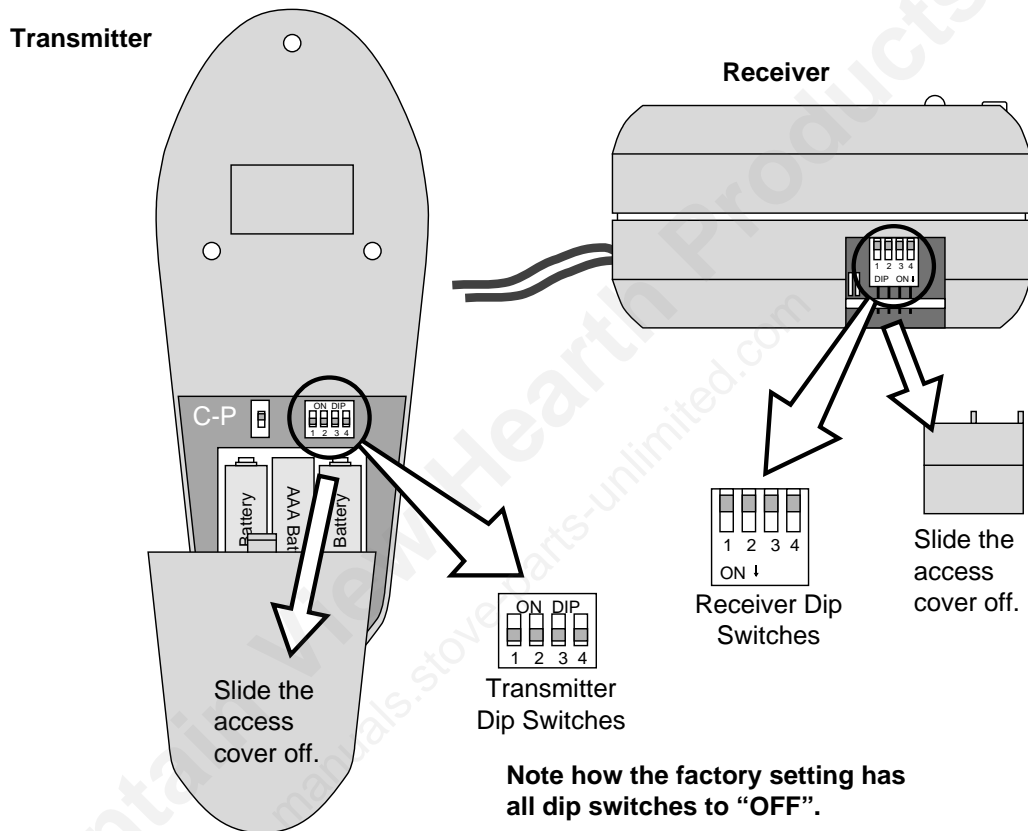

Pellet Modulating Remote

2 Follow the directions below to install the receiver.



Make sure the appliance is unplugged before installing the remote receiver.

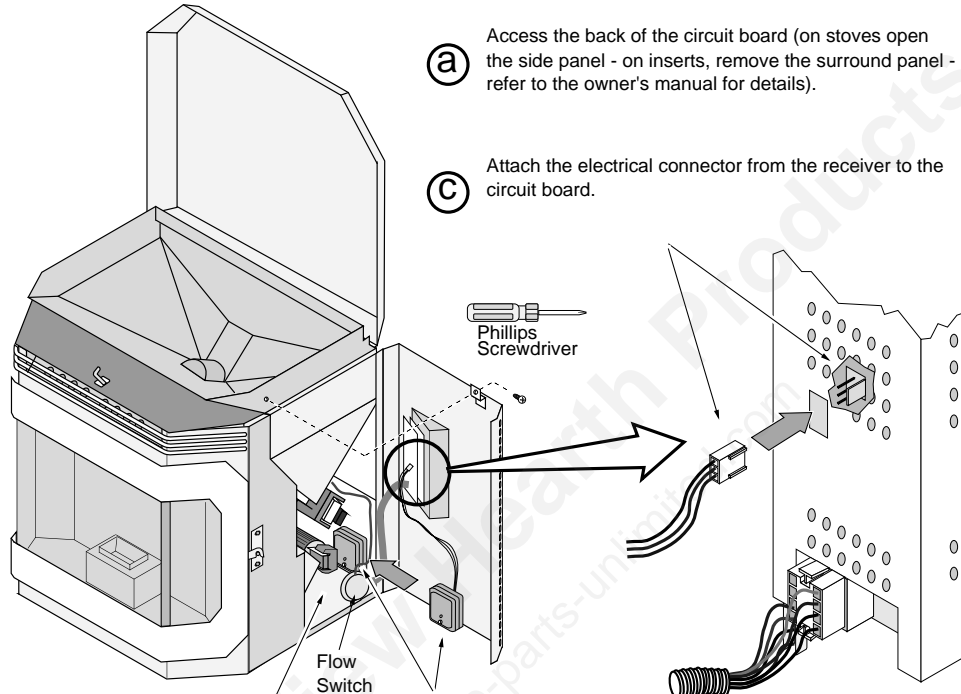

(a) Access the back of the circuit board (on stoves open the side panel - on inserts, remove the surround panel - refer to the owner's manual for details).

(c) Attach the electrical connector from the receiver to the circuit board.

Yankee Pellet Stove

place the remote receiver flat underneath the convection blower.

(b)

Newport & Pioneer Stoves

place the remote receiver upright against the back panel behind the flow switch (**failure to properly place the receiver will lead to heat damage**).

Newport Bay & Pioneer Bay Pellet Inserts

place the remote receiver on the floor of the fireplace, near the control board.



WARNING: The wires must not contact any hot or moving components (use lock-ties if necessary).

3 Plug the pellet heater in and press the button on the receiver to reset the security code. Test operation of the remote.

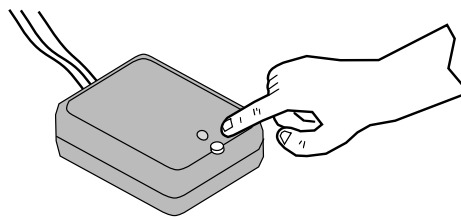

Pellet Modulating Remote

BEFORE YOU BEGIN:

Warning Read all of the safety precautions in the owner's manual included with your heater before using this remote control.

MODES OF OPERATION:

The thermostat can be operated in the following modes:

Manual Use the remote to turn the heater on and off.

TO TURN THE HEATER ON AND OFF MANUALLY:

Use the arrow keys to adjust the temperature up to 90° F (or 32° C).

To turn the heater on, press this button until "Auto" appears. To turn off, press this button until "Off" appears.

NOTE: if the room does reach 90° F. (or 32° C), the heater will shut off.

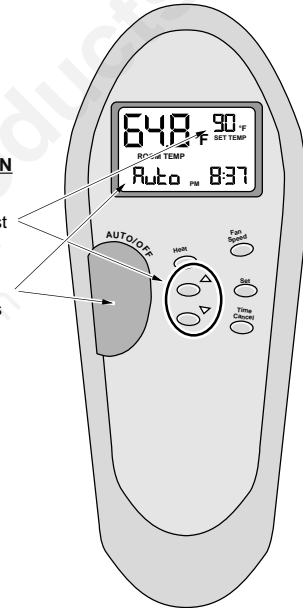

Auto Let the remote automatically turn the heater on when it is too cool, turn it off when it is too hot. You set the desired temperature with the remote.

TO START THERMOSTAT MODE:

Use this key to toggle the thermostat mode on. The display will indicate "Auto" in the lower left.

HINT: If your heater turns on and off frequently, adjust the flame height down slightly for a more consistent heat output.

TO ADJUST TARGET TEMPERATURE:

Use the arrow keys to adjust the target temperature to the desired level.

The heater will turn on and off to keep the room temperature near the target temperature.

IMPORTANT OPERATIONAL NOTE:

The thermostat has a built-in time delay to keep the heater from constantly turning on and off. This means the target temperature may be slightly higher (2° or 3°) than the room temperature – do not adjust the target temperature – the heater will turn on in a few minutes.

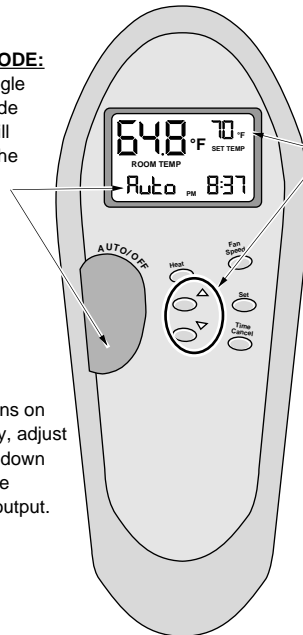

Pellet Modulating Remote

MODES OF OPERATION (continued):

Timed

Set the time you wish the heater to remain on.

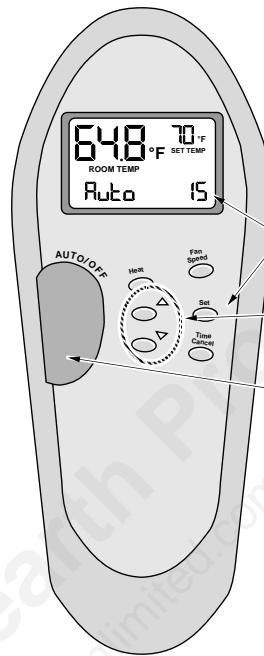

TO SET TO TIMED OPERATION:

- Press the "Set" button once.
- Use the arrow keys to set the number of minutes you would like the heater to stay on (1 to 120 minutes).
- Press the Auto On/Off switch until "Auto" appears.

The heater will turn on and stay running for the number of minutes displayed.

NOTE: The remote must be in "Auto" to remain in timed mode.

FEATURES:

Child-Proof

This switch (located behind the battery cover - see the illustration on the following page) disables the buttons on the front of the remote. Thermostat and timed functions are still operational (but are not adjustable).

This is the "Child Proof" Switch

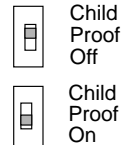

The child proof switch disables the buttons on the front of the remote. Thermostat and timed functions remain operational.

The words "Child Proof" appear here when this features is turned on.

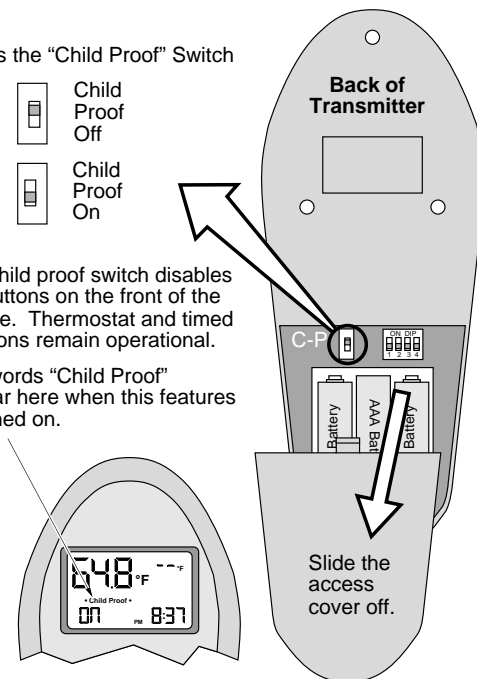

Pellet Modulating Remote

FEATURES (continued):

Burn Rate Follow the instructions to the right to adjust the burn rate.

TO ADJUST THE BURN RATE:

Press on the "Heat" button to adjust the burn rate. The burn rate will toggle from the lowest burn rate (H1) to the highest burn rate (H6).

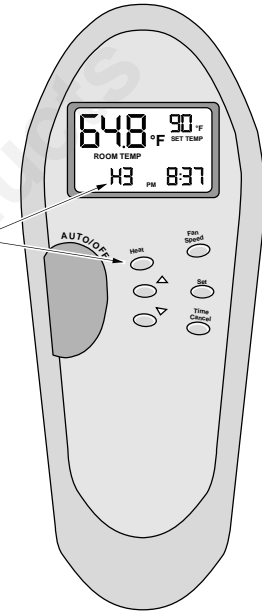

Fan Speed Follow the directions to the right to adjust the fan speed.

TO ADJUST THE FAN SPEED:

Press on the "Fan Speed" button to adjust the fan speed. The fan speed will toggle from low (F1) to high (F2).

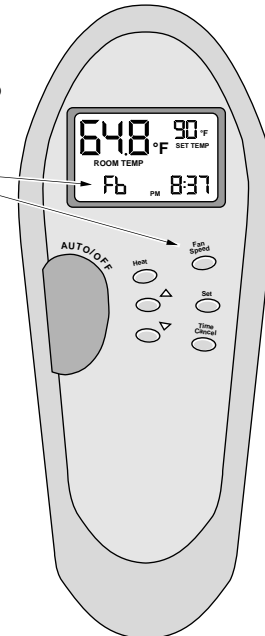

OPERATION WITH DEAD BATTERIES

If the heater is on (any mode) and the batteries go dead, the heater will remain on. To operate the heater, use the switch on the heater to turn the heater on and off.

Pellet Modulating Remote

SETTING THE TIME

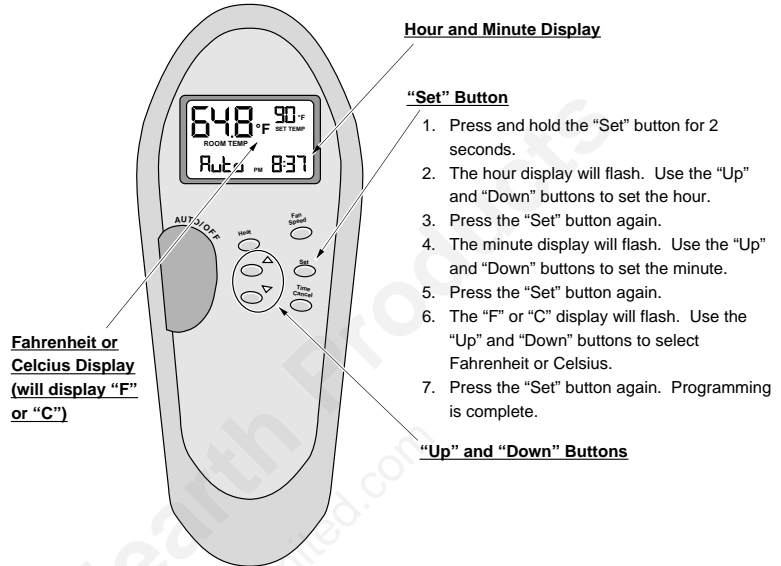

REPLACING THE BATTERIES

Follow the directions to the right to replace the batteries inside the remote control.

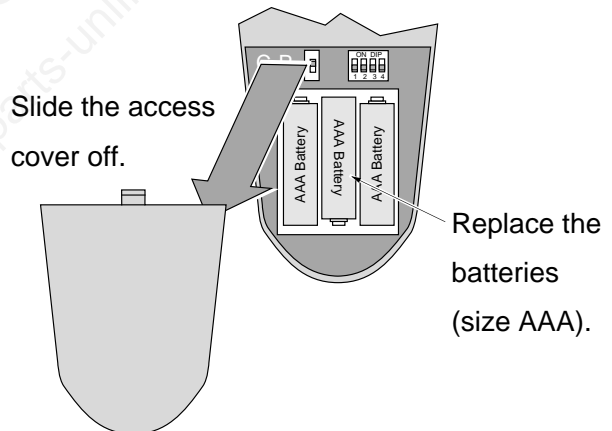

Mountain View Hearth Products
manuals.stove-parts-unlimited.com

Restrictor Settings

Restrictor Adjustment	1-2
Small Stoves & Inserts	3
Large Stoves	4-5
Large Inserts	6

Mountain View Hearth Products
manuals.stove-parts-unlimited.com

Restrictor Adjustment

Restrictor Adjustment

- 15-20 Minute Burn
- Set On High Burn
- Watch Burn Activity
- Adjust
- Verify On Low Burn

- The appliance should be fully up to temperature (15-20 Min.) before attempting adjustment.
- Turn the appliance to high.
- Watch the burn pot activity to determine need for adjustment.
- Adjust as necessary.
- Turn heat setting to low to verify it operates well on this setting.

AIR FLOW INTO THE BURN POT

SHOULD	SHOULD NOT
Be strong enough to create complete burning of the pellets	Burn so slow that incoming pellets smother the fire
Be strong enough to blow ash out of the burn pot	Let excessive amounts of ash lie in the burn pot
	Blow unburned pellets out of the burn pot

Pellet Stove Restrictor Setting

CONDITION	Close the restrictor providing more restriction of air flow (Too much air)	Open the restrictor less restriction of air flow (Too little air)
Stove goes out on low burn	X	
Unburnt pellets are blowing out of burn pot	X	
Fly ash remains in the burn pot		X
Pellet smoothers the fire		X
Stove works fine during day but at night goes out leaving an unburnt pile of pellets (Due to cooler night temperature, draft in vent increases)	X	

Small Stoves/Inserts Restrictor Setting Instruction

Setting the Restrictor

In extremely rare cases the vent will produce too much draft for the heater. This leads to an inefficient burn, and in some cases, the flame going out. Excessive draft typically happens in tall vertical installations or very short horizontal installations. The factory restrictor setting is wide open.

When to Adjust the Restrictor (for qualified installers only):

- If un-burned pellets are expelled from the firepot often (make sure they are un-burned, not just cylindrical embers), the restrictor needs adjustment.
- If on LOW the pellets burn too quickly and the flame goes out, the restrictor needs adjustment.

How to Adjust the Restrictor (for qualified installers only):

- Ⓒ Use these index marks to gauge restrictor movement. Move the restrictor one position, then inspect the stove's performance over a long period of time.

NOTE: You will not notice much change in the flame after adjusting the restrictor. Check stove performance over a long period of time.

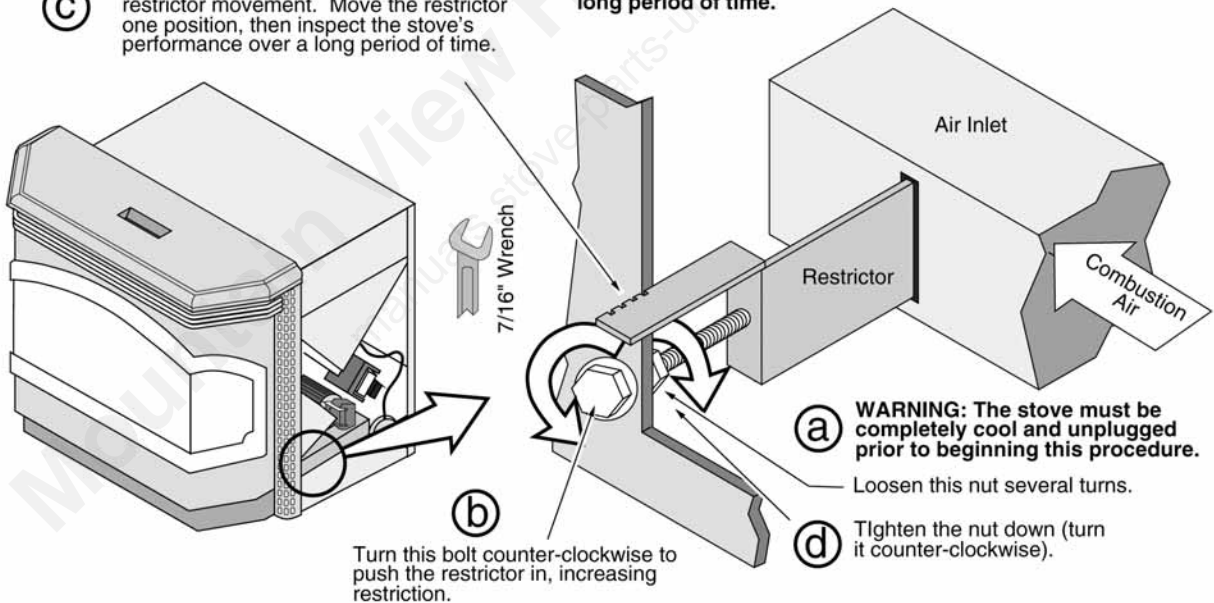

Large Stove Restrictor Setting Instruction - Yankee

Restrictor Adjustment

The exhaust restrictor “fine tunes” your appliance, ensuring it pulls the correct amount of air through the firebox. Altitude, vent configuration, and other factors make restrictor adjustment necessary for every installation.

NOTE: the optimal restrictor position will vary over time as soot builds up inside the exhaust system – make sure the homeowner knows how to visually inspect the flame and adjust the restrictor.

Not Enough Air:

If clinkers develop or the flame appears lazy and slow to blow the ash out of the firepot, pull the restrictor outward until the flame becomes active and the firepot holes remain clean. **NOTE:** If the restrictor is fully out (“5”), yet the firepot does not remain clean, the stove needs to be cleaned and checked for air leaks (see “Maintenance” section of this manual).

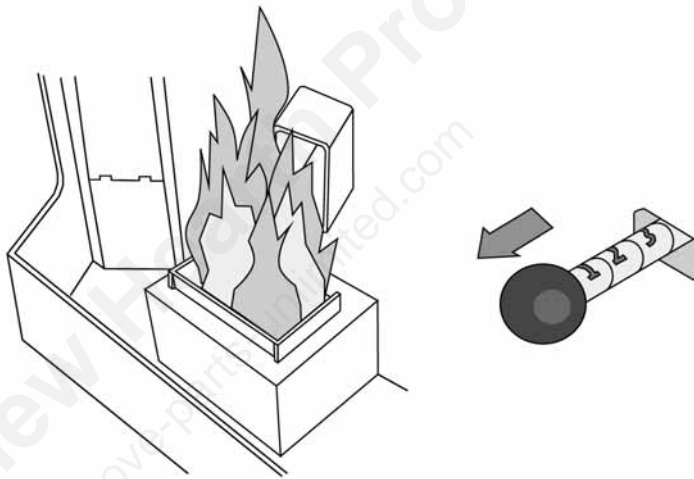

Too Much Air:

If the flames are too active (small, flickering flames) or if burning pellets are expelled from the firepot, move the restrictor rod inwards until the flame slows down and no burning pellets are expelled. Another symptom of too much air is the heater “blowing the fire out” – a condition in which the pellets burn faster than they are fed (this is most common on low).

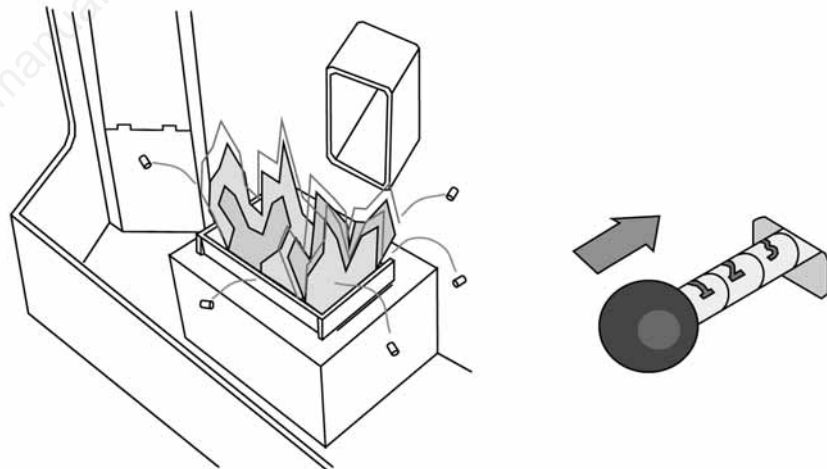

Large Stove Restrictor Setting Instruction - Astoria

Restrictor Adjustment

The exhaust restrictor “fine tunes” your appliance, ensuring it pulls the correct amount of air through the firebox. Altitude, vent configuration, and other factors make restrictor adjustment necessary for every installation.

NOTE: the optimal restrictor position will vary over time as soot builds up inside the exhaust system – make sure the homeowner knows how to visually inspect the flame and adjust the restrictor.

Not Enough Air:

If clinkers develop or the flame appears lazy and slow to blow the ash out of the firepot, pull the restrictor outward until the flame becomes active and the firepot holes remain clean. **NOTE:** If the restrictor is fully out (“5”), yet the firepot does not remain clean, the stove needs to be cleaned and checked for air leaks (see “Maintenance” section of this manual).

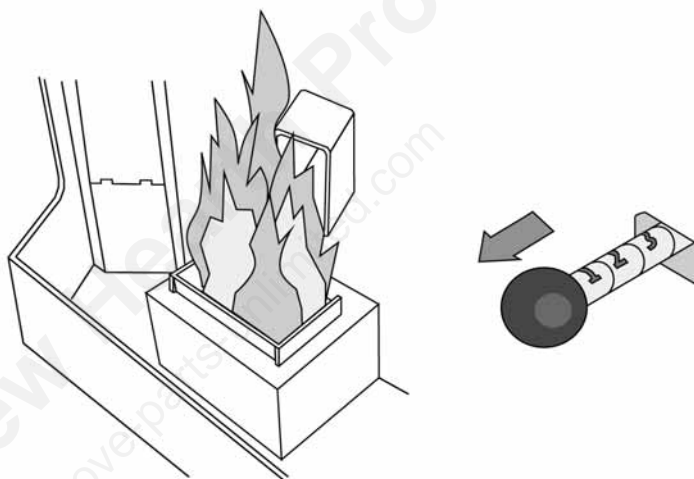

Too Much Air:

If the flames are too active (small, flickering flames) or if burning pellets are expelled from the firepot, move the restrictor rod inwards until the flame slows down and no burning pellets are expelled. Another symptom of too much air is the heater “blowing the fire out” – a condition in which the pellets burn faster than they are fed (this is most common on low).

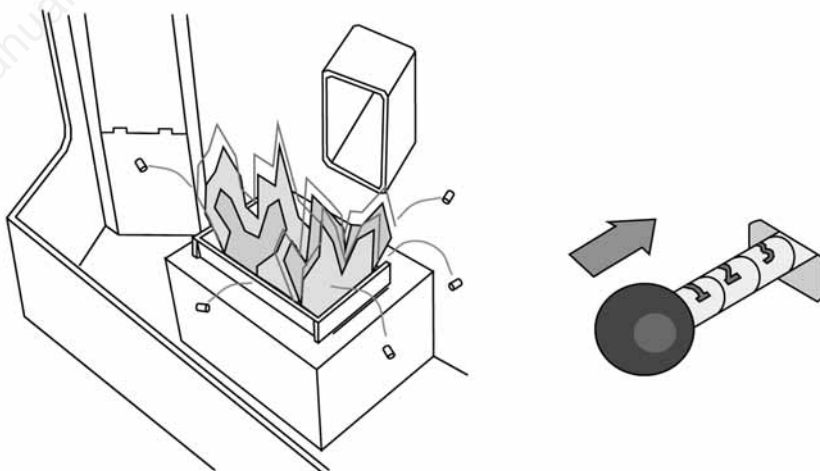

Large Insert Restrictor Setting Instruction

Restrictor Adjustment

The exhaust restrictor “fine tunes” your appliance, ensuring it pulls the correct amount of air through the firebox. Altitude, vent configuration, and other factors make restrictor adjustment necessary for every installation.

NOTE: the optimal restrictor position will vary over time as soot builds up inside the exhaust system – make sure the homeowner knows how to visually inspect the flame and adjust the restrictor.

Not Enough Air:

If clinkers develop or the flame appears lazy and slow to blow the ash out of the firepot, pull the restrictor outward until the flame becomes active and the firepot holes remain clean. **NOTE:** If the restrictor is fully out (“5”), yet the firepot does not remain clean, the stove needs to be cleaned and checked for air leaks (see “Maintenance” section of this manual).

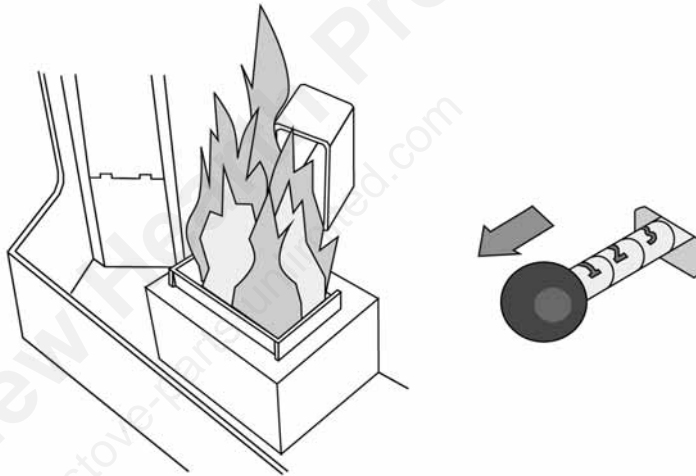

Too Much Air:

If the flames are too active (small, flickering flames) or if burning pellets are expelled from the firepot, move the restrictor rod inwards until the flame slows down and no burning pellets are expelled. Another symptom of too much air is the heater “blowing the fire out” – a condition in which the pellets burn faster than they are fed (this is most common on low).

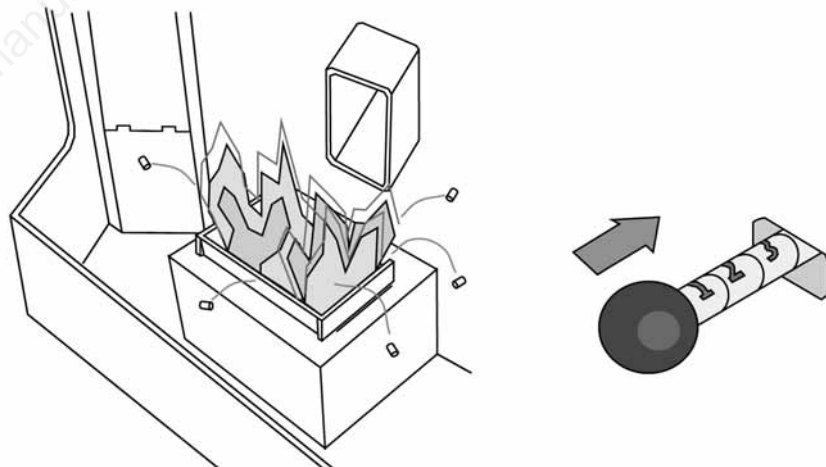

Mountain View Hearth Products
manuals.stove-parts-unlimited.com

Troubleshooting Checklist

Appliance Will Not Power Up	1
Pellets Will Not Feed	2-3
Pellets Do Not Light	4
Appliance Will Not Move Into Run Mode	5
Improper Burn Characteristics	6
Fault Light Comes On	7
Pellet Appliance Shuts Down	8
Dirty Glass	9
Lack of Heat	10
Thermostat Does Not Operate Stove	11
Remote Does Not Operate Stove	12
Ash Leakage	13
Sooting	14
Appliance Will Not Shut Off	15
Smoke In The House	16

SYMPTOMS	AREA OF FOCUS	OCCURRENCE/TIMING OF PROBLEM	POSSIBLE CAUSE	SOLUTIONS
Control Board Does Not Light Up	Operator	During Start Up	Lack of Operational Knowledge	Educate
Control Board Does Not Light Up	Selector Switch	During Start Up	Selector Switch Not In Proper Position	Place In Manual or Automatic Position
Control Board Does Not Light Up	No 110 v Power Supply	During Start Up	Dead Outlet	Repair Dead Outlet
Control Board Does Not Light Up	Fuses (Main) (Board)	During Start Up	Blown Fuse	Check and replace Main (Rear of Unit) or Board Fuse
Control Board Does Not Light Up	Control Board	During Start Up	Defective Control Board	Replace Board

APPLIANCE WILL NOT POWER UP

SYMPTOMS	AREA OF FOCUS	OCCURRENCE TIMING OF PROBLEM	POSSIBLE CAUSE	SOLUTIONS
Pellets Will Not Feed	Operator	At Start Up	Operator Error	Educate
Pellets Will Not Feed	Thermostat	At Start Up	No Call For Heat	Reset Temperature Setting
Pellets Will Not Feed	Fuel	At Start Up	Out of Pellets	Fill Hopper With Fuel
Pellets Will Not Feed	Fuel	At Start Up	Prime Time	Allow Time to Fill Auger Flight
Pellets Will Not Feed	Fuel	At Start Up	Voids In Fuel Supply	Shake Down Pellets
Pellets Will Not Feed	Auger	At Start Up	Auger Jamb	Clear Auger Jamb
Pellets Will Not Feed	Fuel	At Start Up	Pellets Broken Into Small Pieces & Lots of Fines	Clean Out Fuel & Replace with New Fuel
Pellets Will Not Feed	Vertical Drop Tube	At Start Up	Clogged Vertical Drop Tube	Clean Out Vertical Drop Tube
Pellets Will Not Feed	Wiring	At Start Up	Wired Wrong	Rewire
Pellets Will Not Feed	Flow Switch	At Start Up	No Vacuum Kinked Hose	Straighten or replace Hose
Pellets Will Not Feed	Flow Switch	At Start Up	No Vacuum Plugged Barbed Connector	Remove Connection From Blower & Clean
Pellets Will Not Feed	Flow Switch	At Start Up	No Vacuum - Dirty Exhaust Blower Clogged Vent	Clean As Necessary

PELLETS WILL NOT FEED

SYMPTOMS	AREA OF FOCUS	OCCURRENCE/TIMING OF PROBLEM	POSSIBLE CAUSE	SOLUTIONS
Pellets Will Not Feed	Safety Snap Switches	At Start Up	Overheated or Defective Safety Snap Switches	Fix overheating or Replace Defective Snap Disk
Pellets Will Not Feed	Auger Motor	At Start Up	Defective Auger Motor	Replace Motor
Pellets Will Not Feed	Auger Motor	At Start Up	Loose or Misaligned Locking Collar	Properly Locate and Tighten Locking Collar
Pellets Will Not Feed	Auger	At Start Up	Defective Bearing or Dirty Bearing	Replace Bearing

PELLETS WILL NOT FEED

SYMPTOMS	AREA OF FOCUS	OCCURRENCE TIMING OF PROBLEM	POSSIBLE CAUSE	SOLUTIONS
Pellets Feed But Do Not Light	Operate	At Start Up 6-8 minutes	Lack of Operator Knowledge	Educate
Pellets Feed But Do Not Light	Burn Pot	At Start Up 6-8 minutes	Burn Pot Ports Plugged Lack of Maintenance	Clean Ports in Burn Pot
Pellets Feed But Do Not Light	Igniter	At Start Up 6-8 minutes	Defective Igniter	Replace Igniter
Pellets Feed But Do Not Light	Air Flow	At Start Up 6-8 minutes	Exhaust System lack of Maintenance	Clean Exhaust Blower and Total Exhaust System
Pellets Feed But Do Not Light	Air Flow	At Start Up 6-8 minutes	Air Leaks at Gasketed Areas	Check and replace Adjust All Gasketed Areas
Pellets Feed But Do Not Light	Fuel	At Start Up 6-8 minutes	Poor Fuel, Too Small or Too Many Fines	Change Fuel Source
Pellets Feed But Do Not Light	Control Board	At Start Up 6-8 minutes	Defective Control Board	Replace Control Board

PELLETS WILL NOT LIGHT

SYMPTOMS	AREA OF FOCUS	OCCURRENCE TIMING OF PROBLEM	POSSIBLE CAUSE	SOLUTIONS
Appliance Will Not Move to Run Mode	Start Up	At Start Up Beginning of Run Mode	Unsuccessful Start Mode - Pellets Do Not Light	See Pellets Will Not Light
Appliance Will Not Move to Run Mode	System Disk	At Start Up Beginning of Run Mode	Defective Systems Disk	Replace
Appliance Will Not Move to Run Mode	Control Board	At Start Up Beginning of Run Mode	Defective Control Board	Replace

APPLIANCE WILL NOT GO INTO RUN MODE

SYMPTOMS	AREA OF FOCUS	OCCURRENCE TIMING OF PROBLEM	POSSIBLE CAUSE	SOLUTIONS
Improper Flame	Maintenance	Anytime During the Burn Cycle	Dirty Burn Pot & or Exhaust System	Perform Required Maintenance
Improper Flame	Restructure Adjustment	Early During the Burn Cycle	Improper Restructure Adjustment	Set Restructures
Improper Flame	Fuel	Early During the Burn Cycle	Poor Quality Fuel	Replace With A Quality Premium Fuel
Improper Flame	Air Flow	Early During the Burn Cycle	Air Leaks Around Gasketing	Find & Eliminate Any Gasket Air Leaks
Improper Flame	Venting	Early During the Burn Cycle	Improper Venting Exceeds Limitations	Correct Venting Problems
Improper Flame	Outside Air source	Early During the Burn Cycle	Exceeded Outside Air Limitations	Reinstall in Accordance With Outside Air limitations
Improper Flame	Control Board	Early During the Burn Cycle	Defective Control Board Regulating Feeds	Replace Control Board

IMPROPER APPLIANCE BURN CHARACTERISTICS

SYMPTOMS	AREA OF FOCUS	OCCURRENCE TIMING OF PROBLEM	POSSIBLE CAUSE	SOLUTIONS
Fault Light Comes On	Fuel	Anytime During the Operation	Out of Pellets	Refill Hopper With Fuel
Fault Light Comes On	Start-up Procedure	During Start-up Mode	Stove Did Not Start	(See Stove Does Not Start)
Fault Light Comes On	Power	Anytime During Operation	Power Outage	Restart Stove

FAULT LIGHT COMES ON

SYMPTOMS	AREA OF FOCUS	OCCURRENCE TIMING OF PROBLEM	POSSIBLE CAUSE	SOLUTIONS
Stove Shuts Off	Operator Knowledge	Well Into the Burn Cycle	Completed Heat Cycle	Educate the Operator
Stove Shuts Off	Fault Light Is Lit Up	Well Into the Burn Cycle	Fuel Has Run Out	Refuel & Restart Appliance
Stove Shuts Off	Fault Light is Lit Up	Well Into the Burn Cycle	Power Outage	Restart the Appliance
Stove Shuts Off	Fuel	Well Into the Burn Cycle	Fuel Too Small	Replace Fuel With Better Quality
Stove Shuts Off	Exhaust Blower & Exhaust System	Well Into the Burn Cycle	Dirty, Needs Maintenance	Clean Blower & Exhaust System
Stove Shuts Off	Pellets Pile Up	Well Into the Burn Cycle Often During the Night	Improper Restrictor Setting	Restrict Air Flow By Closing the Restrictor Exhaust on Large Intake on Small Appliances
Stove Shuts Off	Safety Devices	Well Into the Burn Cycle	Overheated Snap Disk or Defective	Correct Overheating or Replace Defective Switch
Stove Shuts Off	Safety Flow Switch	Well Into the Burn Cycle	No Vacuum Sensed or Defective Flow Switch	Correct Lack of Vacuum or Replace Defective Flow Switch
Stove Shuts Off	Control Board	Well Into the Burn Cycle	Defective Control Board	Check and Replace As Necessary
Stove Shuts Off	Exhaust Blower Overheats	Well Into the Burn Cycle	Early Astoria Stove Models Occasionally Had Overheating Problems	Order Ventilated Back Quarter Panels

PELLET APPLIANCE SHUTS DOWN

SYMPTOMS	AREA OF FOCUS	OCCURRENCE/TIMING OF PROBLEM	POSSIBLE CAUSE	SOLUTIONS
Dirty Glass	Maintenance	During Burn Process	Dirty Burn Pot Holes Block	Clean
Dirty Glass	Maintenance	During Burn Process	Dirty Exhaust Blower or Exhaust Chamber	Clean
Dirty Glass	Fuel	During Burn Process	Low Quality Fuel	Use Premium Grade Fuel
Dirty Glass	Restrictor	During Burn Process	Improper Setting	Reset Restrictor
Dirty Glass	Gasket	During Burn Process	Leaking Door Gasket Seal	Adjust or Replace Gasket
Dirty Glass	Gasket	During Burn Process	Glass Gasket Leak	Replace Gasket
Dirty Glass	Ash Dump	During Burn Process	Sloppy Ash Dump Seal	Tighten or Replace
Dirty Glass	Glass Door Air Slots	During Burn Process	Glass Air Wash Slots Plugged	Clean

DIRTY GLASS

SYMPTOMS	AREA OF FOCUS	OCCURRENCE TIMING OF PROBLEM	POSSIBLE CAUSE	SOLUTIONS
Lack of Heat	Expectations	During Burn Time	Unrealistic Expectations	Educate
Lack of Heat	Heat Exchange Tubes	During Burn Time	Heat Exchange Tubes Need Cleaning	With Built In Tube Rake, Clean Tubes
Lack of Heat	Restrictor	During Burn Time	Restrictor Not Set Properly	Set Restrictor
Lack of Heat	Fuel	During Burn Time	Poor Quality Fuel	Purchase Better Quality Fuel
Lack of Heat	Gasketing	During Burn Time	Gasket Leaks	Check & Replace As Necessary All Gasketing
Lack of Heat	Heat Exchanger Baffles	During Burn Time	No Heat Exchanger Baffles Installed Only Large Inserts)	Place Insert Baffles As Shown in the Installation Directions
Lack of Heat	Control Board	During Burn Time	Defective Control Board	Replace Control Board

LACK OF HEAT

SYMPTOMS	AREA OF FOCUS	OCCURRENCE TIMING OF PROBLEM	POSSIBLE CAUSE	SOLUTIONS
Thermostat Does Not Turn On Stove	Thermostat	Start Up	Heat Influence on Thermostat By Some Heat Source	Move Thermostat or Remove Heat Source Influence
Thermostat Does Not Turn On Stove	Wiring	Start Up	Improperly Wired Thermostat	Wire Properly
Thermostat Does Not Turn On Stove	Thermostat	Start Up	Defective Thermostat	Replace Thermostat
Thermostat Does Not Turn On Stove	Wiring	Start Up	Broken Thermostat	Replace Wire
Thermostat Does Not Turn On Stove	Control Board	Start Up	Defective Control Board	Replace Control Board

THERMOSTAT DOES NOT OPERATE APPLIANCE

SYMPTOMS	AREA OF FOCUS	OCCURRENCE TIMING OF PROBLEM	POSSIBLE CAUSE	SOLUTIONS
Remote Does Not Operate	Operator	Start Up Mode	Operator Error	Educate Operators In Remote Use
Remote Does Not Operate	Batteries	Start Up Mode	Dead or Wrong Orientation of Batteries	Replace or Properly Orientate Batteries
Remote Does Not Operate	Frequency	Start Up Mode	Sender & Receiver Not Matched	Match Frequency
Remote Does Not Operate	Wiring	Start Up Mode	Remote Wiring Unplugged	Plug In
Remote Does Not Operate	Sending Unit	Start Up Mode	Defective	Replace
Remote Does Not Operate	Receiving Unit	Start Up Mode	Defective	Replace

REMOTE DOES NOT OPERATE APPLIANCE

SYMPTOMS	AREA OF FOCUS	OCCURRENCE/TIMING OF PROBLEM	POSSIBLE CAUSE	SOLUTIONS
Ash Leakage	Vent	While Appliance is Running	Poor Vent Seals	Properly Seal Vents
Ash Leakage	Blower Housing	While Appliance is Running	Broken Gasket, Leaky Blower Housing	Replace Gasket and/or Seal Blower Housing
Ash Leakage	Ash Pan	While Appliance is Running	Poor Ash Pan Gasket	Replace Ash Pan Gasket

ASH LEAK

SYMPTOMS	AREA OF FOCUS	OCCURRENCE TIMING OF PROBLEM	POSSIBLE CAUSE	SOLUTIONS
Soot On Glass	Maintenance	Anytime During Operation	Dirty Burn Pot or Exhaust System	Perform Regular Maintenance
Soot On Glass	Intake Air	Anytime During Operation	Too Much Restriction	Open Up Restrictor
Soot On Glass	Fuel	Anytime During Operation	Poor Quality Fuel or Moist Fuel	Replace Fuel With Better Quality and/or Dry Fuel
Soot On Glass	Air Leaks	Anytime During Operation	Door and/or Glass Gasket Leaks	Correct Leaks
Soot On Glass	Outside Air	Anytime During Operation	Exceeds O/A Limitation	Correct Incorrect Installation of Outside Air
Soot On Outside of the House	Vent Termination	Anytime During Operation	Too Close To House	Follow Installation - Minimum Distance From House Surface

SOOTING

SYMPTOMS	AREA OF FOCUS	OCCURRENCE/TIMING OF PROBLEM	POSSIBLE CAUSE	SOLUTIONS
Appliance Will Not Shut Off	Realistic Heating Expectations	During Shut Down	Space Too Large To Heat	Educate In Realistic Heating Expectations
Appliance Will Not Shut Off	Convection Blower Circuit	During Shut Down or Start Up	Defective Convection Blower Circuit	Check Convection Blower, Circuit Board, and Replace As Necessary
Appliance Will Not Shut Off	System Disk	During Shut Down	Defective Systems Disk	Replace Systems Disk

APPLIANCE WILL NOT SHUT OFF

SYMPTOMS	AREA OF FOCUS	OCCURRENCE TIMING OF PROBLEM	POSSIBLE CAUSE	SOLUTIONS
Smoke Presence in House	Maintenance	During Burn	Blocked Exhaust Passage or Vent	Clean
Smoke Presence in House	Exhaust Gasketing	During Burn	Leaking Exhaust System Gasket(s)	Replace Leaking Gasket(s)
Smoke Presence in House	Electrical Power	During Burn	Loss of Electrical Power	Reinstate Electrical Power

SMOKE IN THE HOUSE

Mountain View Hearth Products
manuals.stove-parts-unlimited.com

Component Removal

Auger Jam Removal	1
Auger Motor Replacement	2
Auger Replacement	3
Igniter Replacement	4-5
Exhaust Blower Replacement	6-7
Convection Blower Replacement	8-9
Fuse Replacement	10

Mountain View Hearth Products
manuals.stove-parts-unlimited.com

Auger Jam Removal



- Remove the six screws which hold down the auger cover and remove the cover.



Auger Motor Replacement

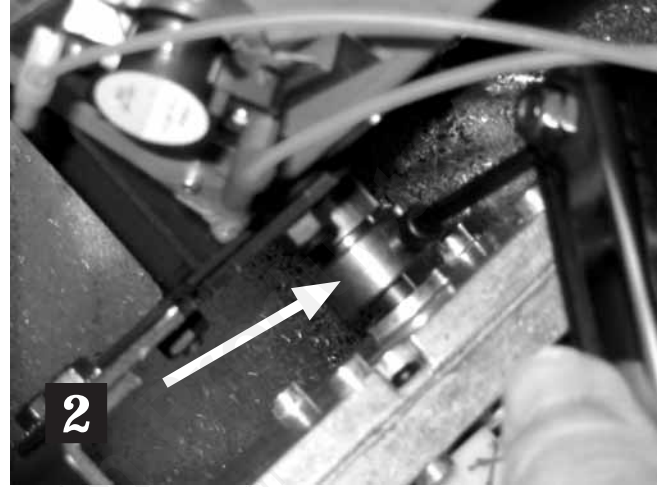
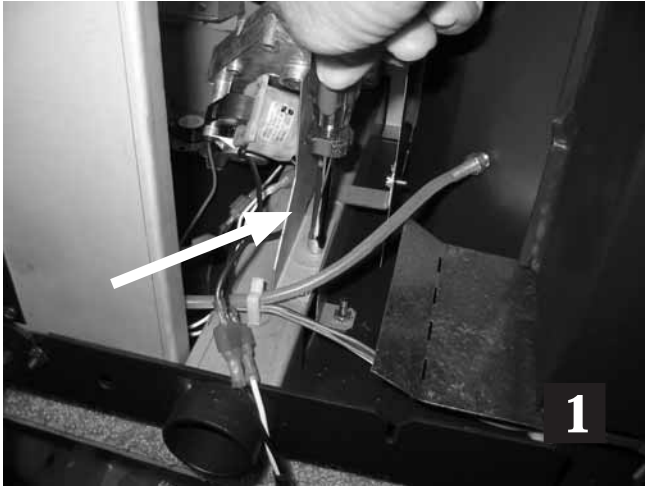

- First remove the motor heat shield located on the right side of the motor (picture #1)
- Loosen the Hex Bolt on the locking collar (picture #2)

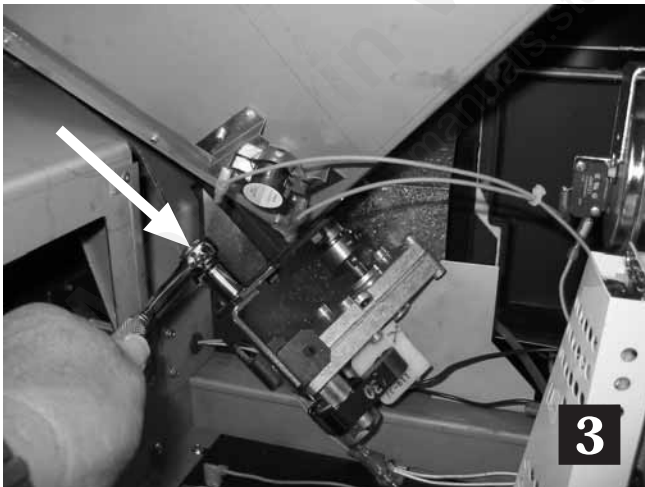

- Next loosen and remove the motor stop (picture #3)
- Pull the motor (picture #4)

Auger Replacement



- Remove the four bolts holding the bearing housing (picture #1)



- Remove the locking collar (picture #2)



- Remove the bearing housing in place (picture #3)



- Remove the auger flight (picture #4)

Igniter Replacement



- Remove the convection blower and with a long extension, remove the 1/4" Hex Screw holding the igniter in place

Igniter Replacement



- Remove the igniter

Exhaust Blower Replacement

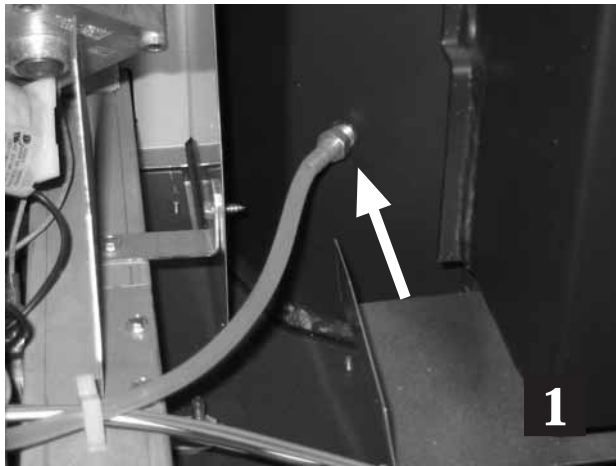

Flow switch vacuum port

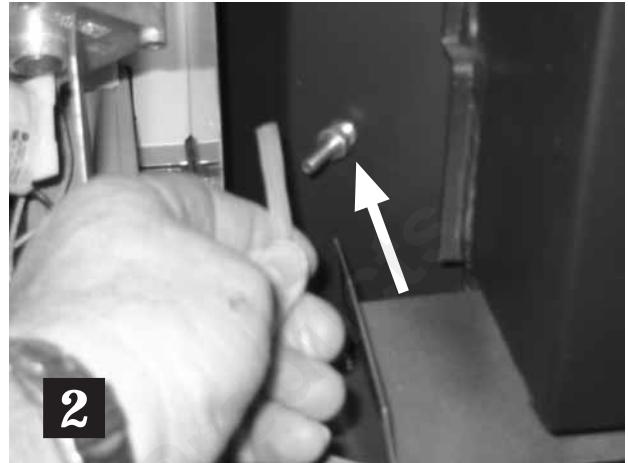

Disconnect hose



Pull plug

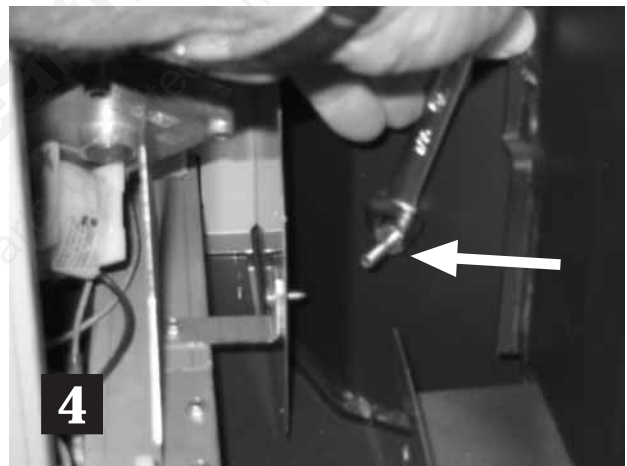

Remove barb and clean opening in connector

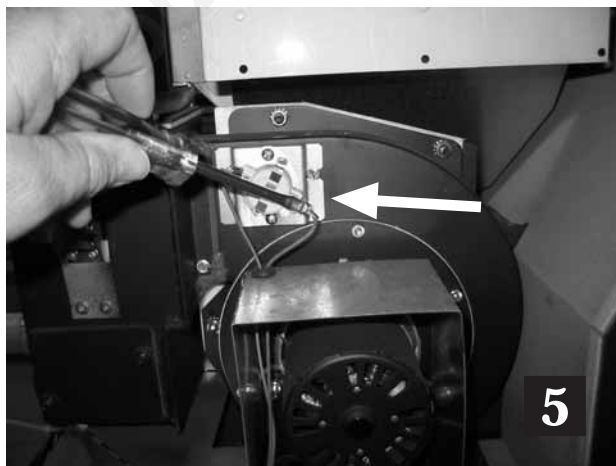

Disconnect wires to systems snap disc (large appliances)

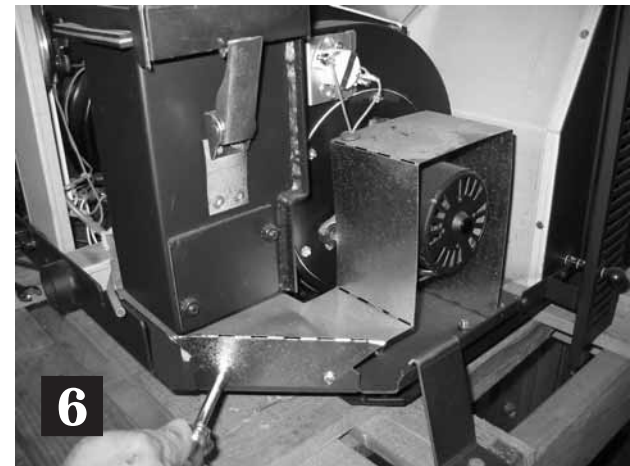

Unbolt blower heat shield (large inserts)

Exhaust Blower Replacement



Remove blower heat shield (large inserts)

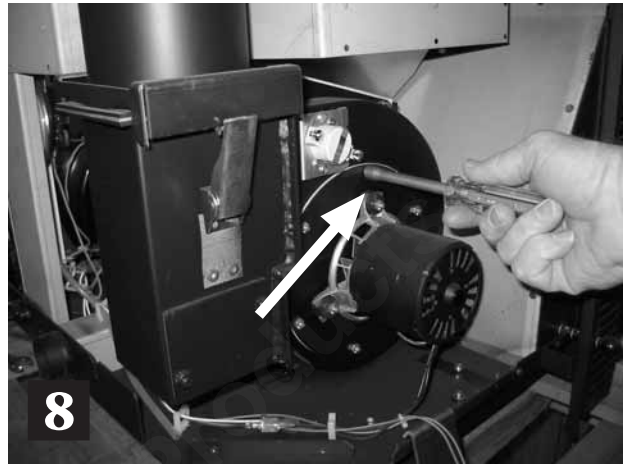

Remove (6) screws on motor housing

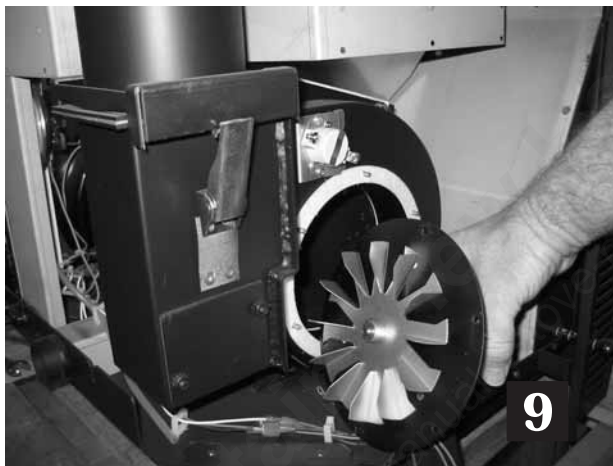

Pull blower

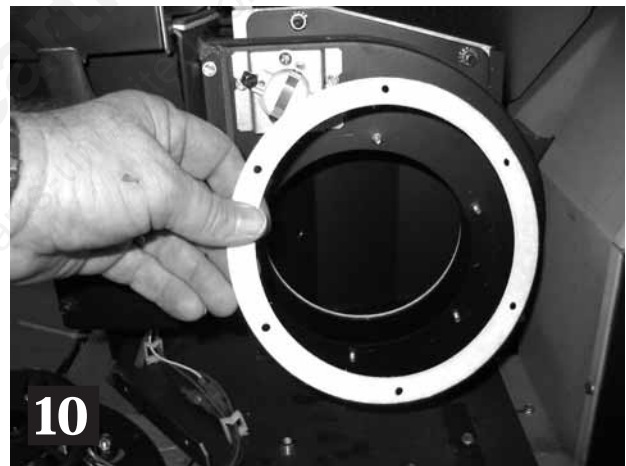

Check gasket and replace as necessary

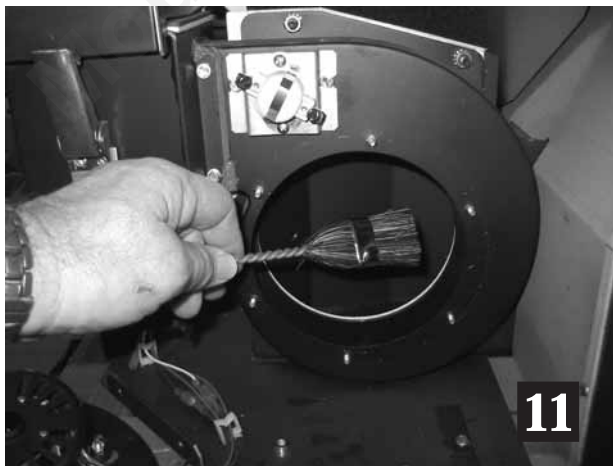

Clean blower housing

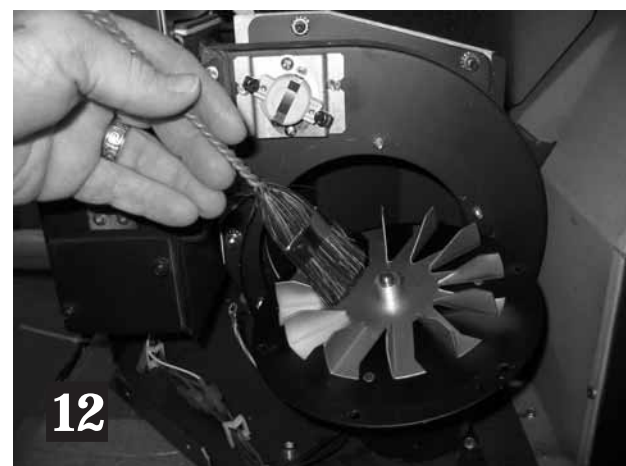

Clean impeller blades

Convection Blower Replacement

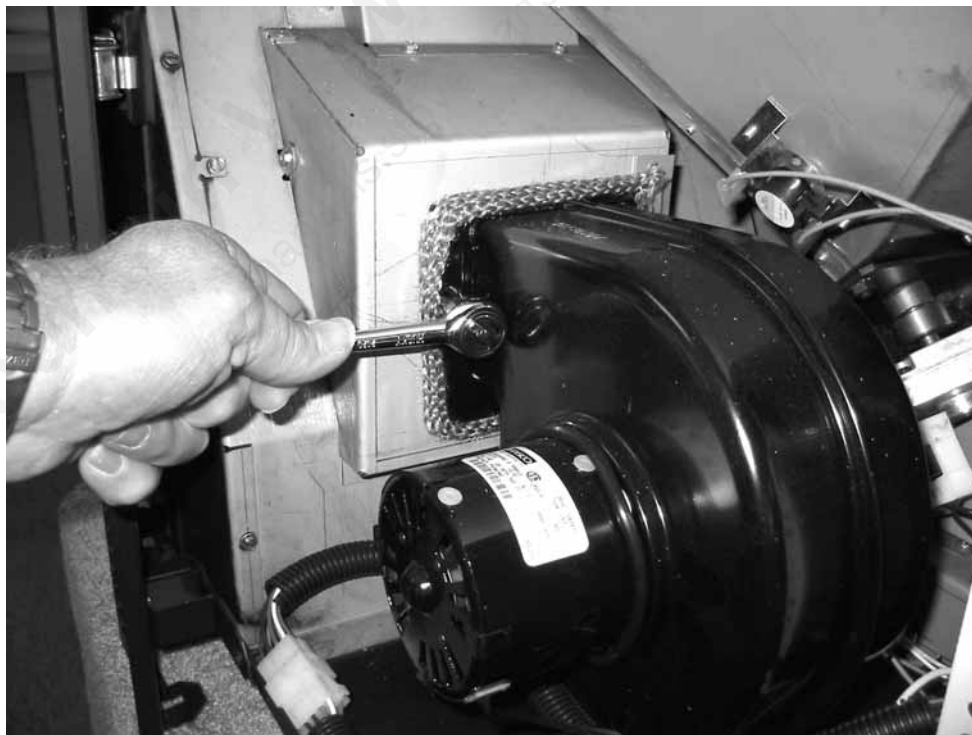

- Remove the single bolt on the left side of the blower and swing the blower to the right, removing it from the right-hand side bracket

Convection Blower Replacement

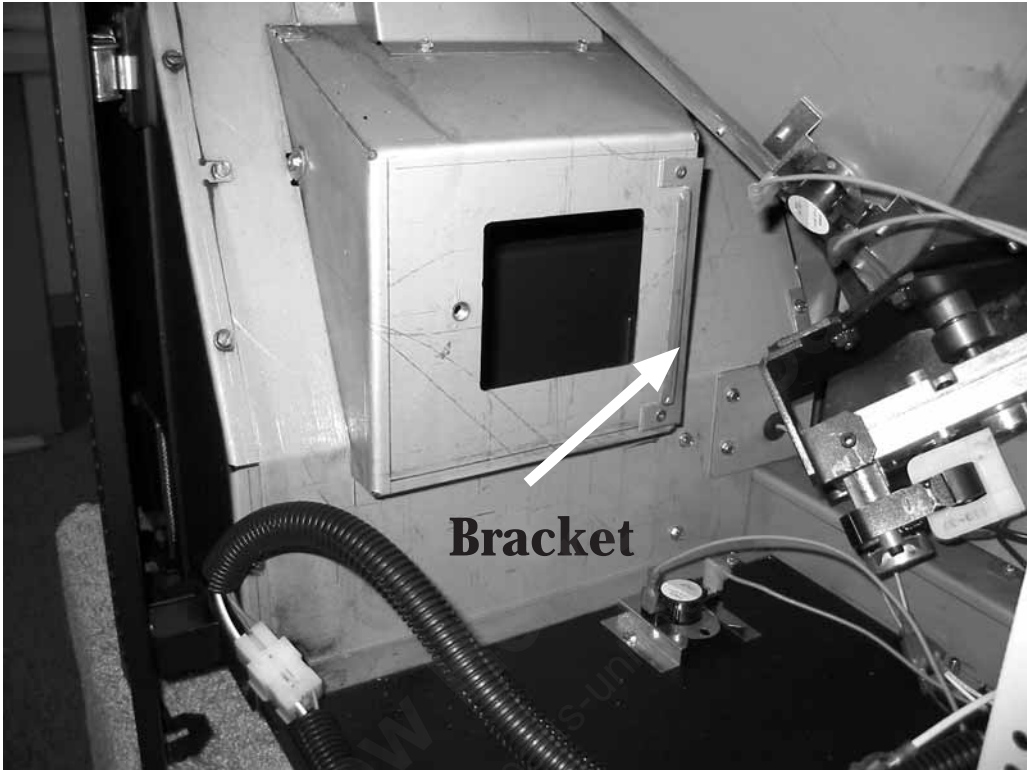

Mountain View
manuals.stove-parts-unlimited.com

Fuse Replacement

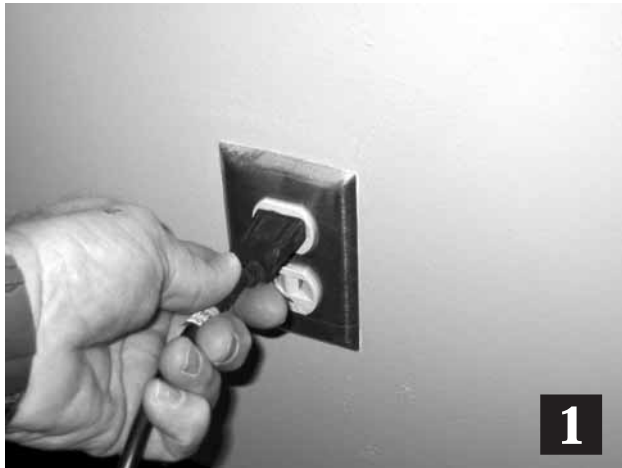

Unplug the electrical power to the appliance

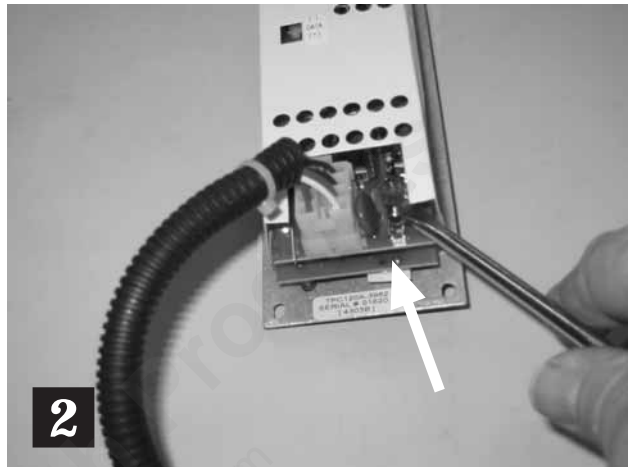

5 AMP quick blow fuse on back of control board

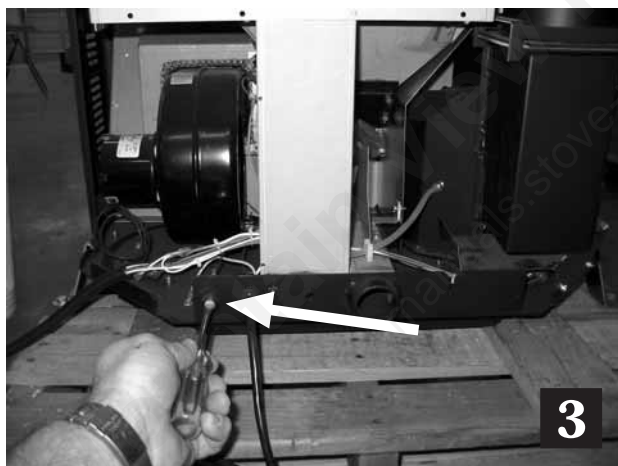

Main fuse (6 AMP quick blow) on back of pellet appliance

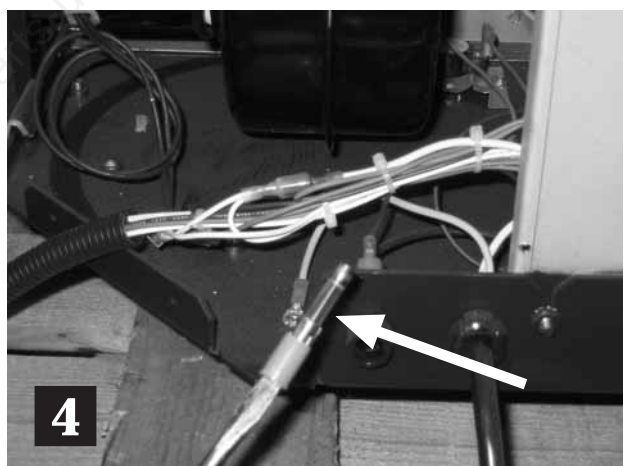

Mountain View Hearth Products
manuals.stove-parts-unlimited.com

Wiring Diagram

Small and Large Pellet Wiring Diagram

1

Mountain View Hearth Products
manuals.stove-parts-unlimited.com

Pellet Wiring Diagram

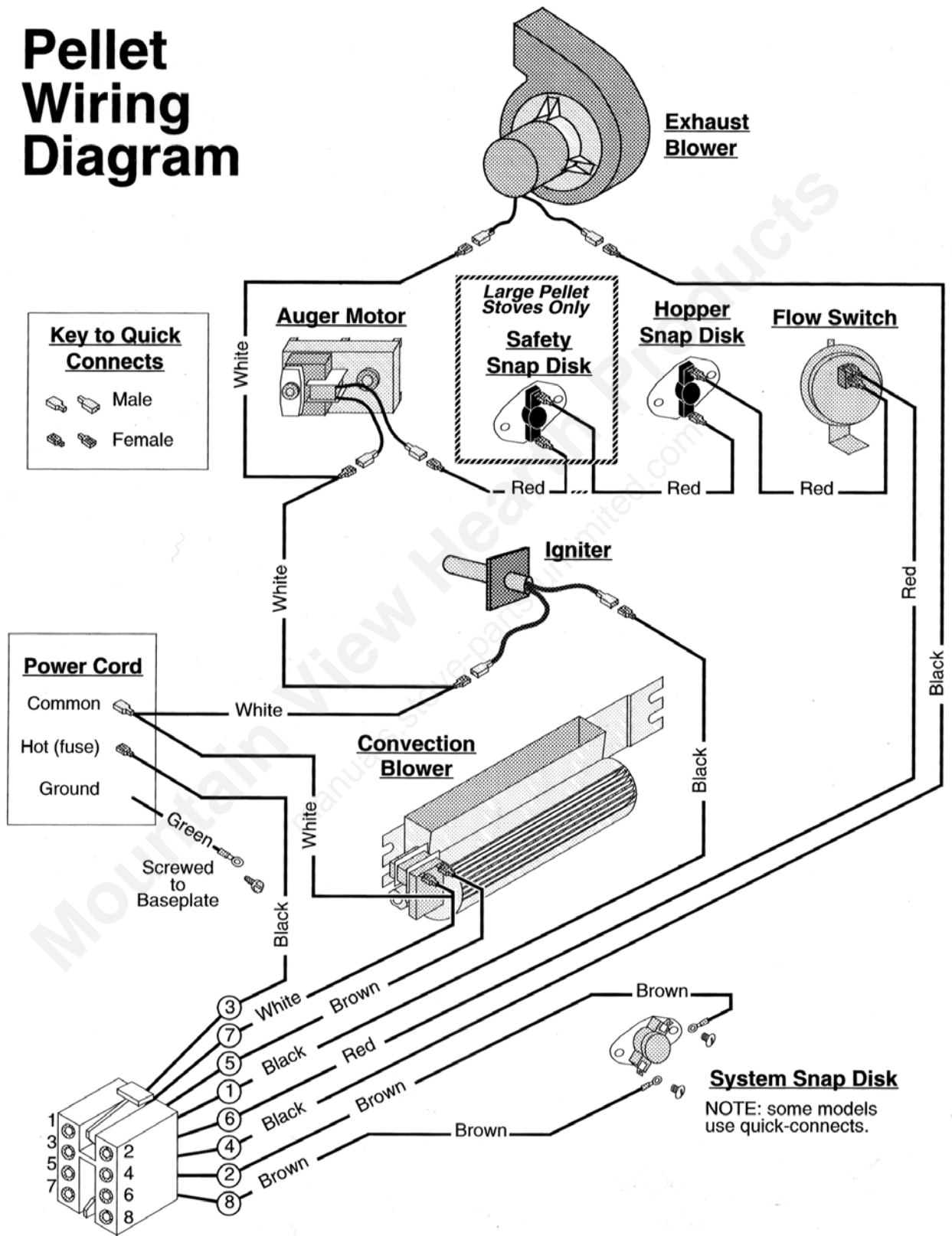

Pellet Stove I. D.

Mountain View Hearth Products
manuals.stove-parts-unlimited.com

Travis Pellet History

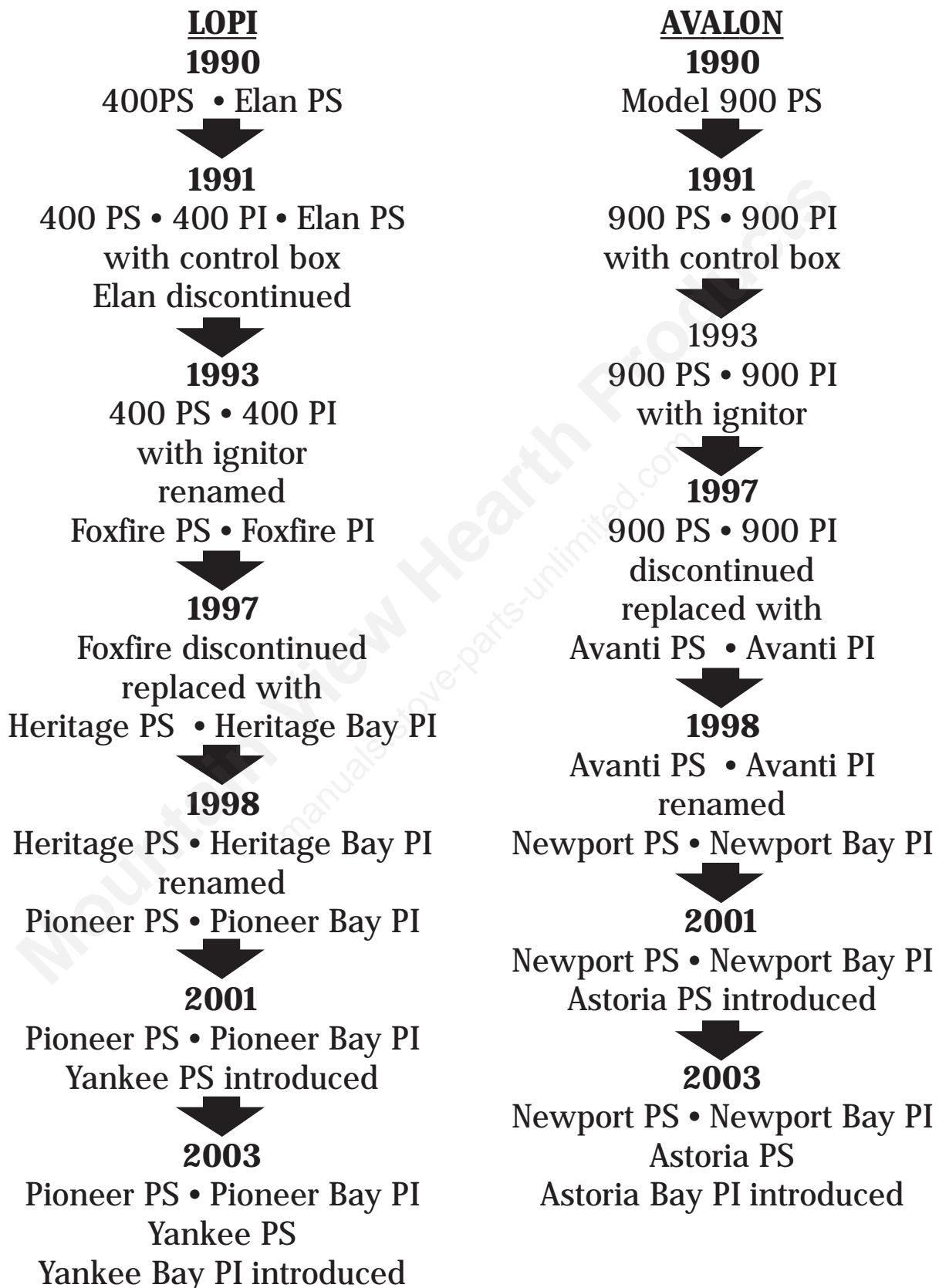

Old LOPI Pellet Identification

Fox Fire, 400 PS (Freestanding Pellet Stove) Series

400 Pellet Stove - 1990
Serial # Range 1020-2000

Freestanding pellet stove. Has 3 piece vertical Ceroboard flat panels in back of firebox. Burnpot and holder are one welded assembly. 8 heat exchanger tubes above fire.

400 Pellet Stove - 1991
Serial # Range 2500-3802

Freestanding pellet stove. Has brick pattern refractory at back of firebox. Separate removable burnpot and holder. Air inlet slider control at lower left side. Enclosed control box has 2 timing blocks and Molex connector.

400 Pellet Stove - 1992
Serial # Range 3803 - 5899

Same as 1991 400, except the clip that holds the removable vertical exhaust ducts (inside the firebox) is welded to the side of the firebox (not the back).

Fox Fire Pellet Stove
Serial # Range 5900 - 14020

Freestanding pellet stove. Has half log cast into refractory at back of firebox. Wired to accept automatic ignitor system.

Fox Fire, 400 PI (Pellet Insert) Series

400 Pellet Insert - 1991
Serial # Range 15002 - 17699

Bay window style pellet insert with framed panels on the left & right bay sides. Has brick pattern refractory at back of firebox. Separate removable burnpot and holder. Air inlet slider control at lower left side. Enclosed control box has 2 timing blocks and Molex connector.

400 Pellet Insert - 1992
Serial # Range 15002 - 17699

Same as 1991 400, except the clip that holds the removable vertical exhaust ducts (inside the firebox) is welded to the side of the firebox (not the back).

Fox Fire Pellet Insert
Serial # Range 17700 - 22420

Bay window style pellet insert with framed mirror panels on the left & right bay sides. Has half log cast into refractory at back of firebox. Wired to accept automatic ignitor system.

Old LOPI Pellet Identification

Elan Freestanding Pellet Stove

Elan Pellet Stove - 1990
Serial # Range 1001 - 1500

Freestanding pellet stove. Has 3 piece vertical Ceroboard flat panels in back of firebox. Burnpot and holder are one welded assembly. 8 heat exchanger tubes above fire.

Elan Pellet Stove - 1991
Serial # Range 3003 - 3700

Freestanding pellet stove. Has brick pattern refractory at back of firebox. Desperate removable burnpot and holder. Air inlet slider control at lower left side. Enclosed control box has 2 timing blocks and Molex connector.

Heritage Bay (Freestanding Pellet Stove) Series

Heritage Bay PS - 1997
Serial # Range 210000 - Present

Distinctive Heritage Bay styling with three-sided bay front door framed with triple arched gold door shell. This stove has automatic operation controlled with electronic circuit board located on right side. Can be used with thermostat. Igniter installed. Has three-sided brick pattern aluminum cast fireback. Large capacity ashpan is concealed in tall pedestal. Triple bar grill covers upper convection chamber.

Heritage Bay (Pellet Insert) Series

Heritage Bay PI - 1997
Serial # Range 410000 - Present

Distinctive Heritage Bay styling with three-sided bay front door framed with triple arched gold door shell. This insert has automatic operation controlled with electronic circuit board located on right side. Can be used with thermostat. Igniter installed. Has three-sided brick pattern aluminum cast fireback. Firebox contains removable ash box with large, shallow ashpan located under the insert. Triple bar grill covers upper convection chamber.

Old Avalon Pellet Identification

900 PS (Freestanding Pellet Stove) Series

900 Pellet Stove - 1990
Serial # Range 1002 - 1501

Freestanding pellet stove. Has 3 piece vertical Ceroboard flat panels in back of firebox. Burnpot and holder are one welded assembly. Air inlet slider control at lower left side. Uses two electronic timing blocks located on left side behind side panel. Switch box at back of stove at upper left.

900 Pellet Stove - 1991
Serial # Range 2500-2900

Freestanding pellet stove. Has brick pattern refractory at back of firebox. Separate removable burnpot and holder. Air inlet slider control at lower left side. Enclosed control box behind left side panel with 2 timing blocks. Wiring harness uses multiple plug Molex connector to join harness to control and switch boxes.

900 Pellet Stove - 1992
Serial # Range 2901 - 4299

Same as 1991 900, except the clip that holds the removable vertical exhaust ducts (inside the firebox) is welded to the side of the firebox (not the back).

900 Pellet Stove - 1993
Serial # Range 4300 - 8111

Freestanding pellet stove. Has brick pattern refractory at back of firebox. Separate burnpot and holder. Control box has 5 amp fuse. Wiring harness equipped for ignitor system. Ignitor option through back of firebox into burnpot holder. Uses 1, 2, or 3 phase ignitor.

900 PI (Pellet Insert) Series

900 Pellet Insert - 1991
Serial # Range 10002 - 10599

Pellet insert. Has brick pattern refractory at back of firebox. Separate removable burnpot and holder. Hopper lid was lift-off assembly. Serial number label is applied to hopper cover - you need to remove the top surround panel to see it.

900 Pellet Insert - 1992
Serial # Range 11000 - 11491

Same as 1991 900, except the clip that holds the removable vertical exhaust ducts (inside the firebox) is welded to the side of the firebox (not the back).

900 Pellet Insert - 1993
Serial # Range 11501 - 13040

Pellet insert. Has brick pattern refractory at back of firebox. Separate burnpot and holder. Hopper lid is hinged. Serial number label is applied to hopper cover - remove the top surround to see it. Control box has 5 amp fuse. Wiring harness equipped for ignitor system. Ignitor option through back of firebox into burnpot holder. Uses 1, 2, or 3 phase ignitor.

Old Avalon Pellet Identification

Newport (Avanti PS) (Freestanding Pellet Stove) Series

Avanti PS - 1997
Name Changed to
Newport in 1999
Serial # Range 120002 - Present

Freestanding pellet stove with three pane glass bay window, swing-open door. Door has gold frame bolted to steel shell and requires a hex key to operate latch. Entire top of stove opens for hopper access. Hopper capacity is 55 lbs. Triple bar grill above door may be gold or black. Gold grill was standard item in 1997, option later. Electronic control board is recessed into the right side. The combustion blower works in tandem with the feed rate - higher feed rate setting causes exhaust blower to run faster. Fully automatic operation if used with thermostat. Has large capacity ashpan with ash dump plate under firebox. Stove has 8 heat exchanger tubes up to Serial # 121700 when 6 heat exchanger tubes were standard. Unit prior to Serial # 121700 also had aluminum cast firebrick in firebox. Units afterwards has cast iron firebrick in firebox. Optional front log introduced in 1998, required the cast iron fireback.

Newport Bay (Avanti PI) (Pellet Insert) Series

Avanti PI - 1997
Name Changed to
Newport Bay in 1999
Serial # Range 32002 - Present

Pellet insert with three pane glass bay window, swing-open door. Door has gold frame bolted to steel shell and requires a hex key to operate latch. Entire top of insert opens for hopper access. Hopper capacity is 35 lbs. Triple bar grill above door may be gold or black. Gold grill was standard item in 1997, option later. Electronic control board is recessed into the right side. The combustion blower works in tandem with the feed rate - higher feed rate setting causes exhaust blower to run faster. Fully automatic operation if used with thermostat. Has a lift-out ash container in the firebox surrounding the burnpot in addition to an ashpan with an ash dump under the firebox. Insert has 8 heat exchanger tubes up to Serial # 320500 when 6 heat exchanger tubes were standard. Unit prior to Serial # 320500 also had aluminum cast firebrick in firebox. Units afterwards has cast iron firebrick in firebox. Optional front log introduced in 1998, required the cast iron fireback.