



TRI-STAR INDUSTRIES, LTD.

Models 150 and 110

MULTIFUEL FURNACE

Installation / Operator's Manual #31072M

FOR YOUR SAFETY

Do not store or use gasoline or other flammable vapors and liquids in the vicinity of this or any other appliance.

If you smell gas:

1. Open windows
2. Don't touch electrical switches
3. Extinguish any open flame
4. Immediately call your gas supplier

CAUTION:

Read Rules for
Safe Operation
& Instructions
CAREFULLY

IMPORTANT:

Installation must be made in accordance with State and local ordinances which may differ from this installation manual.

DANGER

RISK OF FIRE OR EXPLOSION

The Tri-Star Multifuel furnace is designed to burn wood and coal in combination with gas or fuel oil.

The furnace should not be altered in any way.

Do not burn garbage, plastics, drain oil or other flammable liquids.

WARNING

RISK OF FIRE

Firing door and ash door must be closed tightly during operation.

Do not operate with flue draft exceeding .05" - .06" water column.

Do not store flammable materials within stated minimum clearances.

Inspect heat exchanger, smoke pipe and chimney at least twice monthly during the heating season. Soot or creosote accumulations should be removed promptly.

Do not connect this furnace to a chimney flue used for other appliances.

CAUTION

BLACK SURFACES ARE HOT

Do not touch – keep children away.

IMPORTANT

Operate gas or oil burner at least one-half hour per day during the heating season.

TABLE OF CONTENTS

Introduction.....	1-2
Locating Your Furnace.....	2
Clearances.....	2-3
Chimney Requirements.....	3
Assembly Instructions	
Main Furnace Structure.....	4-6
Smoke Pipe.....	7
Draft Regulator.....	7-8
Ductwork.....	8
Oil Burner.....	9
Gas Burner.....	9
Fuel Tanks and Lines.....	9-11
Combustion Air.....	11
Electrical	
General.....	11
Wiring Diagram.....	12
Wiring Schematic.....	13
Installation.....	14-15
Operation	
General.....	15
Oil Firing.....	15-16
Gas Firing.....	16
Solid Fuel.....	15-16
Care and Maintenance.....	17-18
Trouble Shooting.....	18-19
Parts Lists	
Solid Fuel Section.....	20-21
Air Chamber.....	22
Wiring Harness and Blower.....	23
Motorized Natural Draft.....	24
Gas Burner.....	25
Oil Burner.....	26
Warranty.....	27

INTRODUCTION

This manual details the installation, operation and maintenance procedures for the Tri-Star Multifuel Furnace.

IMPORTANT

Before installing and using this furnace, carefully read the entire manual. Installation should only be performed by a qualified furnace installer. Failure to follow these instructions may cause a furnace malfunction, which may result in death, bodily injury and/or damage.

Check your local codes. This installation must comply with their rulings.

SAFETY AND PREVENTIVE MEASURES

1. Use only fuels which are approved for this unit.
2. Oil storage tanks, fuel lines and valves should be installed and tested in accordance with NFPA 31.
3. Do not install a power humidifier on the warm air plenum.
4. Do not overload solid fuel fire chamber.
5. An outside source of combustion air must be supplied to the area where the furnace is located.
6. Use only a masonry or class "A" all-fuel, metal insulated chimney (NFPA 211-Appendix A) with a minimum inside diameter of 6" (8" x 8" for square flues).
7. Do not attempt to light a wood or coal fire when oil or gas vapors may be present. Explosion or flashback may occur, resulting in personal injury.
8. Maintain all clearances.
9. Fire the oil or gas burner at least once daily during the heating season, to ensure clean nozzles and electrodes.
10. Regularly inspect air filter. Clean or replace as necessary.
11. Do not allow anyone to fire the furnace who is unfamiliar with its operation.
12. Install smoke or ionization detectors.
13. Follow a regular service and maintenance schedule.
14. If the furnace requires servicing, be sure it has been allowed to cool and that the electrical power and fuel supply have been shut off.

DISCLAIMER NOTICE

The BTU ranges and heater capacity specifications are provided as a guide only, and in no way guarantee the output or capacity of the units. The actual BTU output depends on the type of fuel being burned and its conditions, the thermostat setting, the draft adjustment and the chimney that the unit is hooked up to. The actual area that the unit will heat depends on factors such as the conditions of the building, heat loss, type of construction, amount of insulation, type of air movement, and the location of the unit.

NOTE: Your Tri-Star warranty is at the end of this book. Be sure to complete and return the warranty registration to the manufacturer. If you have any problem your local dealer cannot help you with, please contact the manufacturer direct.

FURNACE SPECIFICATIONS MODEL 150

OIL BURNER		Wayne model HS
NOZZLE 80°B	INPUT RATING BTU/HR	OUTPUT RATING BTU/HR
1.0	140,000	118,000
.75	105,000	84,000
.85 (STANDARD)	119,000	99,000

GAS BURNER		Wayne model HSG-200
ORIFICE SIZERATING BTU/HRR	INPUT RATING BTU/HR	OUTPUT RATING BTU/HR
.136"	50,000-76,000	40,000-60,800
.199	74,000-116,000	59,200-92,800
.277 (STANDARD)	112,000-164,000	89,600-131,200

Recommended manifold pressure 3.5 W.C.P.

LP		
ORIFICE SIZERATING BTU/HRR	INPUT RATING BTU/HR	OUTPUT RATING BTU/HR
.128"	49,000-68,000	39,200-54,400
.144	66,000-92,000	52,800-73,600
.180	82,000-136,000	65,600-108,800

Recommended manifold pressure 3.5 W.C.P.

BTU Ranges dependent on W.C.P.

Gas/Oil burner efficiency rating 80+%

SOLID FUEL	
FIRE CHAMBER CAPACITY	7.1 cu. ft.
MAXIMUM LOG LENGTH	28"
MAXIMUM COAL CAPACITY	160 lbs.
MAXIMUM BTU OUTPUT	150,000 BTU/HR
ESTIMATED HEATING CAPACITY	2500 sq. ft.
WOOD LOADING DOOR	14" X 14"

BLOWER OPENING	11" X 13"
BLOWER CFM	1500-1650-1800
MOTOR SIZE	1/3 H.P.
AIR FILTER	20" X 20" X 1"

FLUE DRAFT	.05"-.06" Water Column
MAXIMUM STATIC PRESSURE	.25" W.C.
MAXIMUM PLENUM TEMPERATURE	200°F

IMPORTANT

Final burner adjustment must be done by a qualified furnace installer or warranty will be voided.

FURNACE SPECIFICATIONS MODEL 110

OIL BURNER		
Wayne model HS (80+% Efficiency)		
NOZZLE 80°B	INPUT RATING BTU/HR	OUTPUT RATING BTU/HR
.75 (STANDARD)	105,000	84,000
GAS BURNER (NATURAL GAS)		
Wayne model HSG-200 (80+% Efficiency)		
ORIFICE SIZING RATING BTU/HR	INPUT RATING BTU/HR	OUTPUT RATING BTU/HR
.166"	64,500-74,500	51,600-59,600
.199 (STANDARD)	74,000-116,000	59,200-92,800
LP		
ORIFICE SIZING RATING BTU/HR	INPUT RATING BTU/HR	OUTPUT RATING BTU/HR
.128"	49,000-68,000	39,200-54,400
.144	66,000-92,000	52,800-73,600
Recommended manifold pressure 3.5 W.C.P.		
BTU Ranges dependent on W.C.P.		
SOLID FUEL		
FIRE CHAMBER CAPACITY	5.6 cu. ft.	
MAXIMUM LOG LENGTH	23"	
MAXIMUM COAL CAPACITY	120 lbs.	
MAXIMUM BTU OUTPUT	115,000 BTU/HR	
ESTIMATED HEATING CAPACITY	1500 sq. ft.	
WOOD LOADING DOOR	14' X 14"	
BLOWER OPENING	11" X 13"	
BLOWER CFM	1100-1250-1400	
MOTOR SIZE	1/3 H.P.	
AIR FILTER	16" X 20" X 1"	
FLUE DRAFT	.05"-.06" Water Column	
MAXIMUM STATIC PRESSURE	.25" W.C.	
MAXIMUM PLENUM TEMPERATURE	200°F	

FURNACE LOCATION

The furnace is to be installed maintaining clearances as shown in illustration.

Locate the furnace as close to the chimney or flue as possible and near the center of the heat distribution area.

Do not place the Tri-Star directly on a combustible floor. If you're placing it on a combustible floor, an approved fire retardant material, equivalent to 3/8" asbestos millboard should be placed under the furnace. The material must extend at least 16" in front of and 8" on either side of the fuel-loading and ash-removal doors, and underneath the chimney connector and extending at least 2" on either side of the chimney connector.

MINIMUM CLEARANCES

FROM TOP OF WARM AIR PLENUM	FROM FRONT	FROM LEFT SIDE	FROM RIGHT SIDE
2"	48"	10"	30"

CHIMNEY CONNECTOR	FROM BACK	HOT AIR DUCT WITHIN 9-FT. OF PLENUM	HOT AIR DUCT BEYOND 9-FT. OF PLENUM
6" SINGLE WALL	34"	2"	1"
6" DOUBLE WALL	22"		

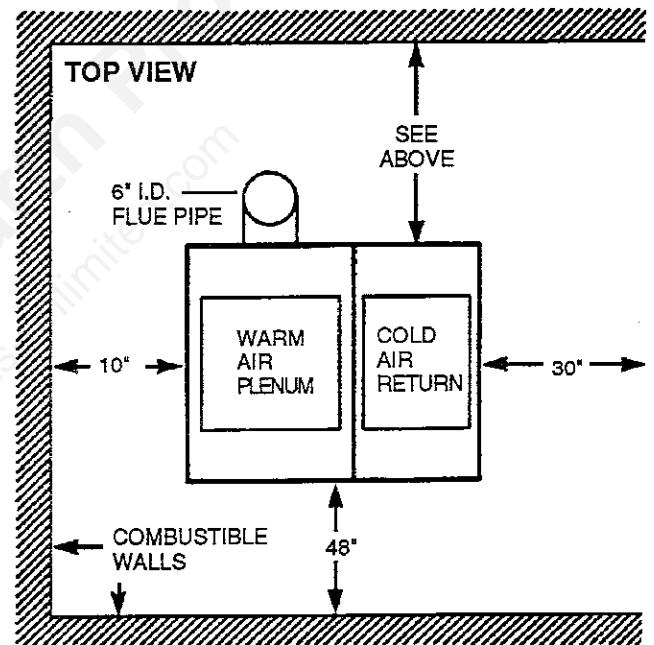

CLEARANCES REQUIRED FOR HOT AIR DUCTS

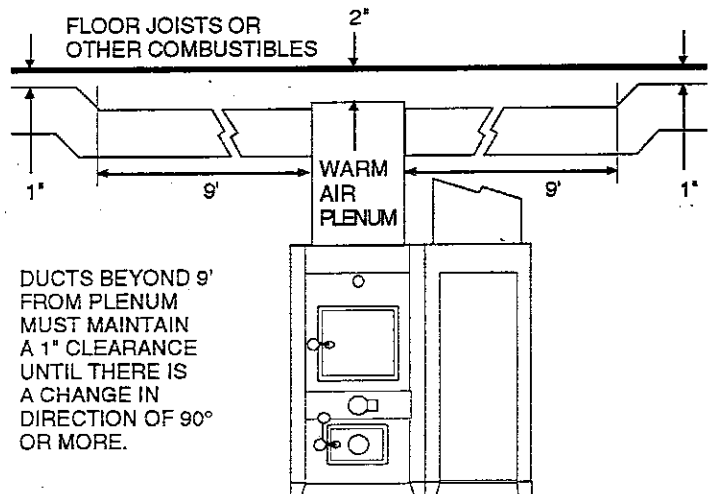

REDUCED CLEARANCES

NFPA and most codes permit reduced clearances to combustible walls and ceilings if adequate protection is added. A common mistake is to assume that sheet metal, masonry, or asbestos board placed directly against a wall protects it. Materials installed in this manner give very little protection. These materials are good heat conductors, so they will be almost as hot on their back side as they are on the exposed side. Therefore, the combustible wall behind it still a fire hazard.

A wall can be kept cool using these items but only if they're mounted and spaced out from the wall by an inch or two to allow free circulation of room air behind the protective panel. The protective panel should start within a few inches of floor level.

The three rules to follow when constructing wall protectors:

1. Non-combustibility of all materials, including mounts or supports.
2. A well ventilated air space between protector and wall.
3. Sufficient strength and rigidity so that the protector and air space will be durable.

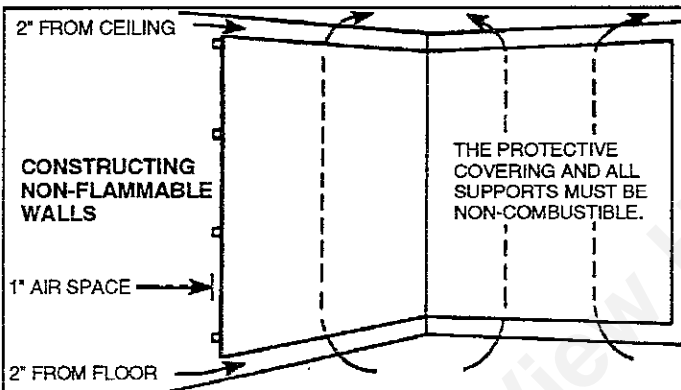

A copy of NFPA standard 90B is available from the National Fire Protection Association Inc., Battery March Park, Quincy, Mass. 02269.

CHIMNEY REQUIREMENTS

DO NOT CONNECT THIS FURNACE TO A CHIMNEY WHICH SERVES ANOTHER APPLIANCE.

The Tri-Star Multifuel Furnace may be connected to a masonry chimney, built in accordance with NFPA 211 Appendix A, or a factory built chimney that is listed and installed in accordance with NFPA 211. Factory built chimneys must be of a kind which is referred to by NFPA as "chimney for residential type and building heating appliances." (Formerly called "Class A or All Fuel"). Outside metal stacks are not acceptable.

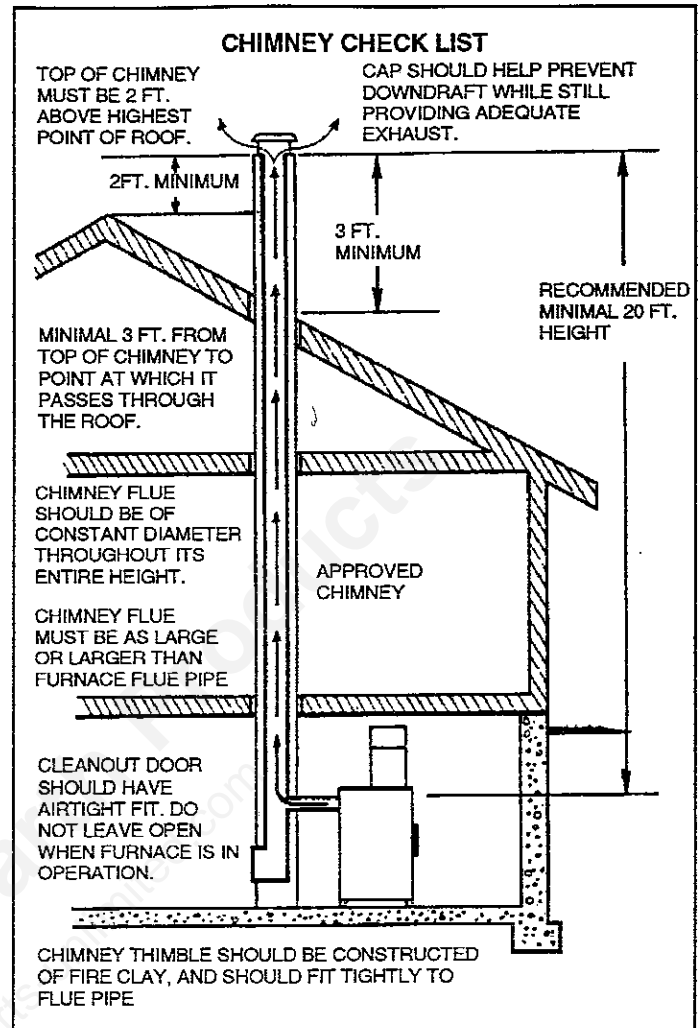

1. The wood furnace should be the only heating appliance using a chimney flue. One furnace per flue.
2. A masonry chimney should have a tile or stainless steel liner.
3. The masonry chimney should not have any missing mortar or loose bricks.
4. There should be no mortar or parts of the chimney blocking the chimney flue.
5. There should be a two inch clearance between any chimney (masonry or metal) and combustibles (such as the house).
6. The chimney should extend at least 2' above the highest point of the house, or 2' above the point at which the chimney is 10' from the roof.
7. The chimney should be relatively straight and vertical.
8. The portion of an all-fuel metal chimney that extends above the roof should be well secured.
9. A masonry chimney should be built on footings and not attached to the house.
10. A rain cap, complete with an animal or bird screen, should be installed on top of the chimney.

ASSEMBLY INSTRUCTIONS

UNPACKING AND INSPECTION

The furnace is shipped in six cartons: 1. solid fuel section, 2. air chamber section, 3. blower, 4. gas or oil burner, 5. draft kit, 6. firepot carton. If any parts are missing or if damage has occurred in shipping, notify your dealer immediately.

PARTS LIST

1. SOLID FUEL SECTION

Two door handles	Two 1/2" locknuts
One fuel door latch	Twenty six 1/4" x 3/4" hex bolts
One ash door latch	One baffle rod extension
One shaker grate handle	Two 1/4" x 1-1/4" carriage bolts
Two 1/2" washers	Two smoke door clips
Four 1/4" hex nuts	One smoke door
Four 1/4" lockwashers	Thirteen 3/8" x 1" bolts
Five 1/4" locknuts	Thirteen 3/8" lockwashers
One pivot bracket	Three #8 tek screws
Four plastic knobs	Four #12 x 3/4" screws
One 1/4" x 1" hex bolt	Instruction manual

2. AIR CHAMBER SECTION

Filter Filler

3. BLOWER CARTON

4. PRE-ASSEMBLED GAS OR OIL BURNER

5. DRAFT KIT

Motorized Natural Draft
Wiring Harness
Thermostat

6. FIREPOT CARTON

Firepot
Pyrolite Firepot Chamber
Venturi Plate
Plate Gasket
Firepot Gasket
Burner Gasket

FUEL & ASH DOOR LATCH INSTALLATION

With two 1/4" x 3/4" hex bolts, lockwashers and nuts attach the door latch to the door latch mounting bracket on the left side of door frame as illustrated. Adjust latch until door closes securely.

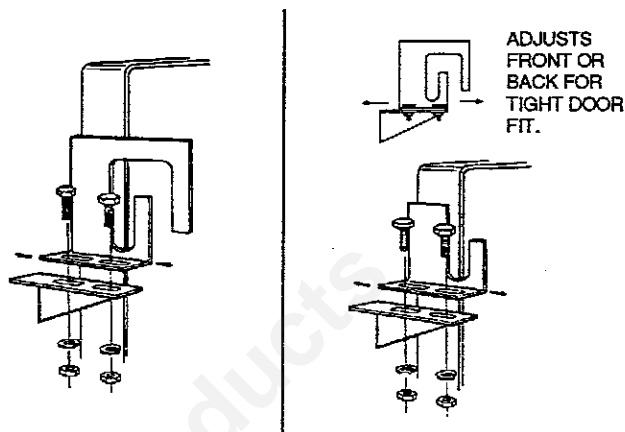

NOTE: Prior to operation, be sure to remove firebrick retaining strips and side shield brick retainer.

FIREBOX

Pre-installed At Factory

The firebrick must be inserted on each side resting on the grate frame. First, place cut brick in each back corner. Place remaining brick in place.

MODEL 150- (6-1/2) BRICKS ON EACH SIDE

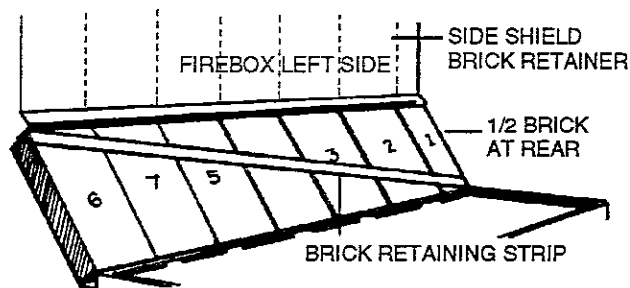

MODEL 110 - (5) FULL BRICKS ON EACH SIDE

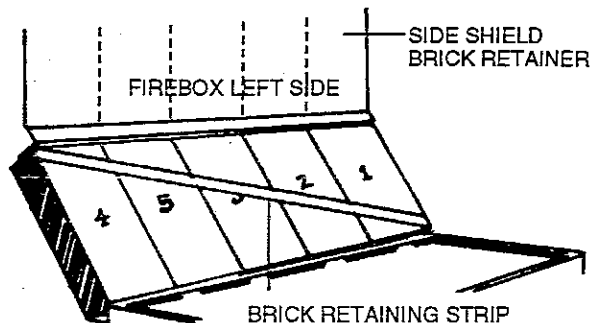

DOOR HANDLE INSTALLATION

Insert door handle into door. From rear side of door place 1/2" washer over threaded part of door handle. Then attach 1/2" lock nut, being careful not to over tighten. Handle should turn freely. Screw plastic knob onto handles.

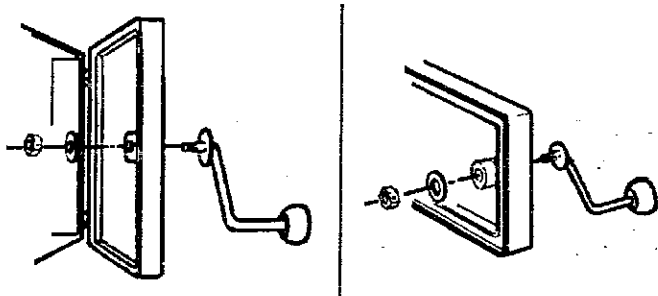

SMOKE CHAMBER:

1. Place one half firebrick in the back of smoke chamber.
2. Slide baffle plate into smoke chamber, flat side down.
3. Place remaining firebrick in smoke chamber as numbered below. (In placing the firebrick in the smoke chamber, lift the left side of firebrick first and drop into place.)

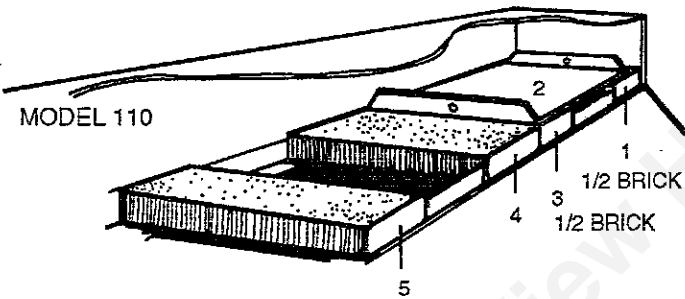
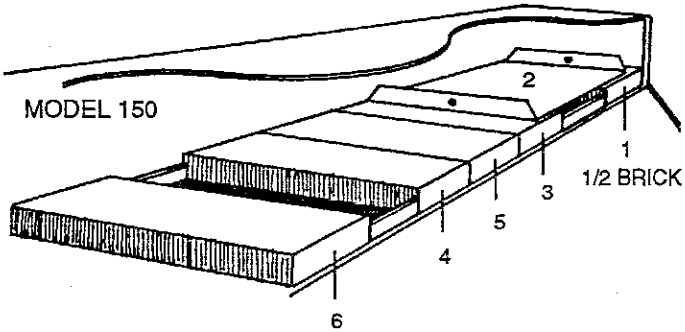

SHAKER GRATE HANDLE INSTALLATION

1. Attach pivot bracket with two 1/4" x 3/4" hex bolts and two 1/4" lock nuts.
2. Attach handle with 1/4" x 1" hex bolt and 1/4" lock nut.
3. Screw plastic knob onto end of handle.

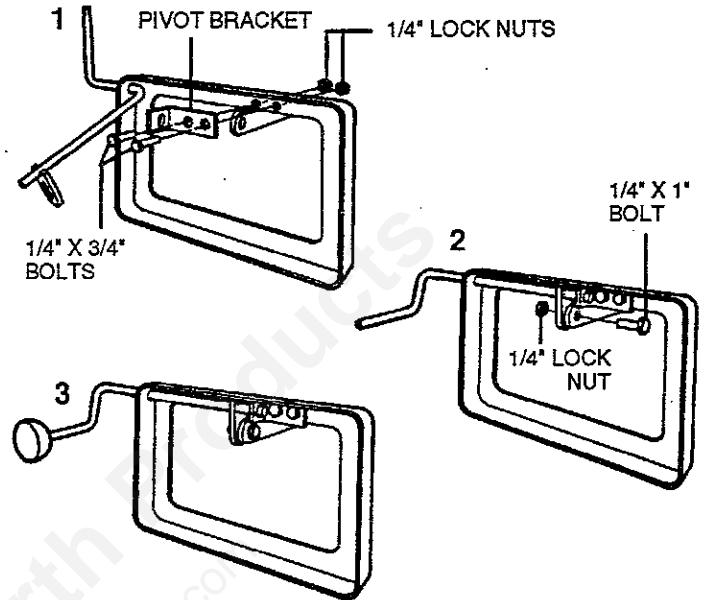

SMOKE DOOR INSTALLATION

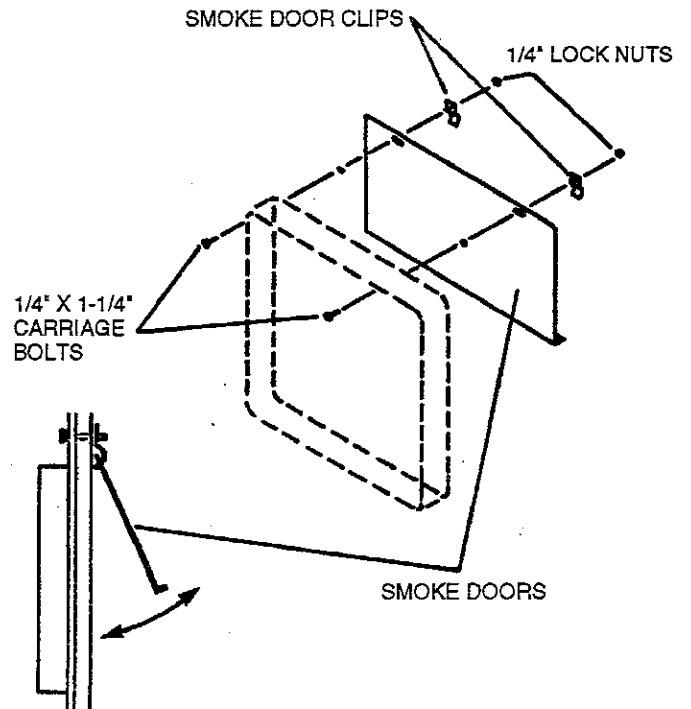

SLIDE BAFFLE ROD ASSEMBLY (PRE-INSTALLED AT FACTORY)

Insert baffle-rod into secondary heat chamber. Secure rod to baffle plate by sandwiching back flange of baffle plate between the two 1/2" hex nuts provided.

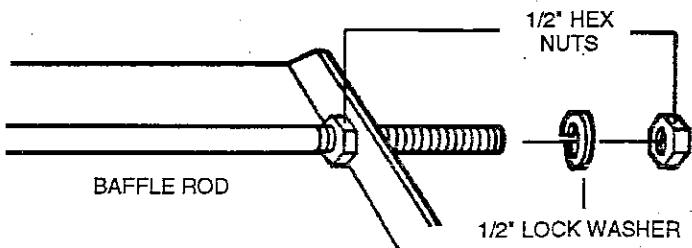

ATTACHING BAFFLE ROD EXTENSION

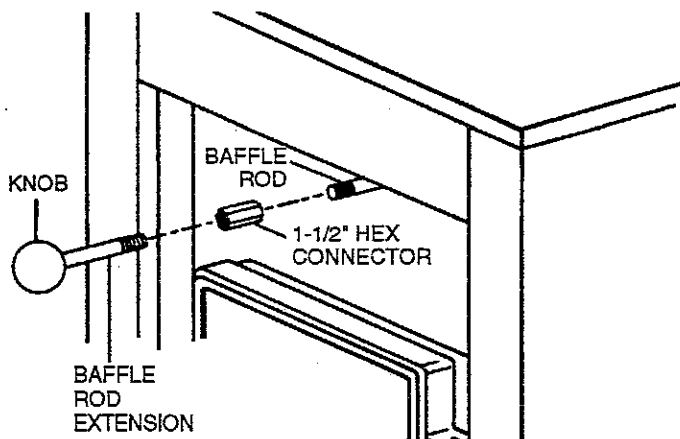

INSTALLING DISTRIBUTION BLOWER

1. Using four #12 x 3/4" sheet metal screws provided, screw distribution blower onto side of furnace.

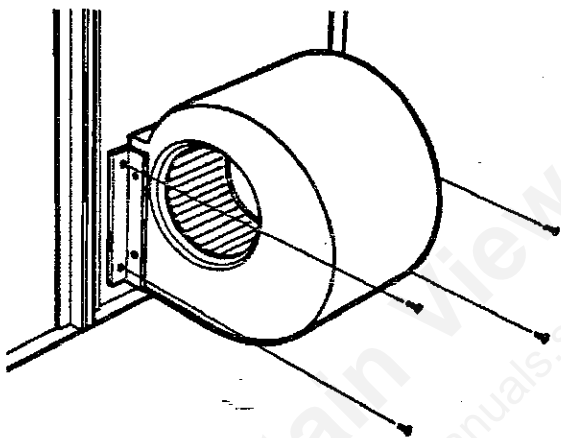

FIREPOT INSTALLATION

1. Be sure pyrolite chamber is seated in firepot and that hole is aligned with blast tube.
2. Attach firepot to mounting frame as illustrated below.

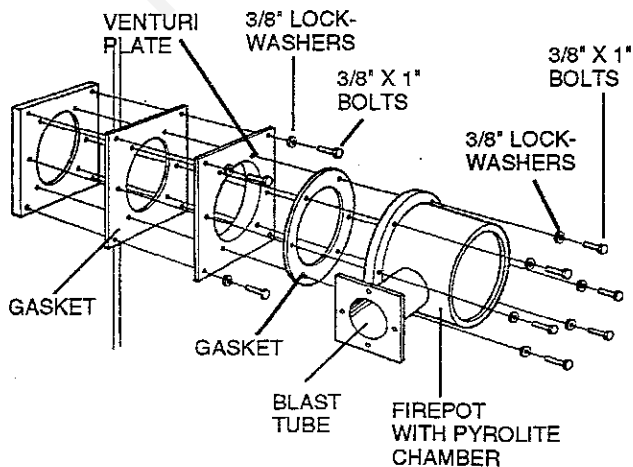

ASSEMBLING FURNACE SECTIONS

Slide air chamber section against solid fuel section and secure with twenty 1/4" x 3/4" bolts.

Check to see that furnace is level.

(Do this before putting on blower and firepot).

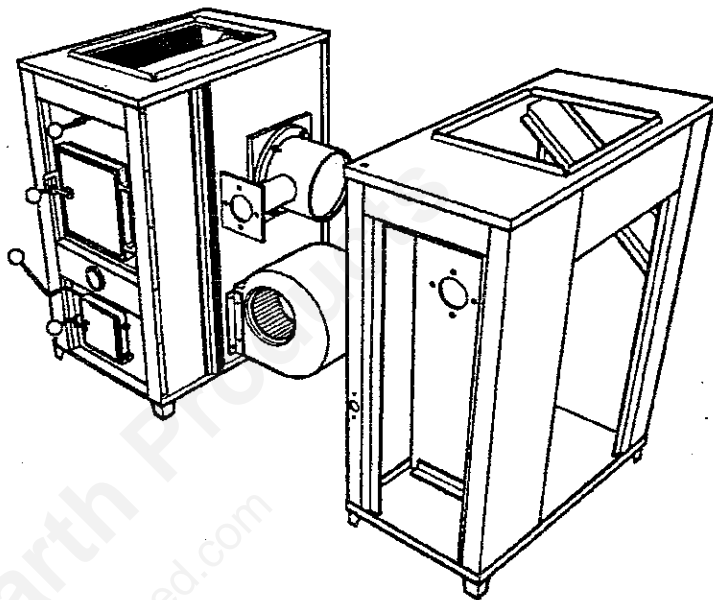

INSTALLING FILTER FILLER

Place filter filler between left and right filter brackets and attach to side of solid fuel section with three #8 tek screws.

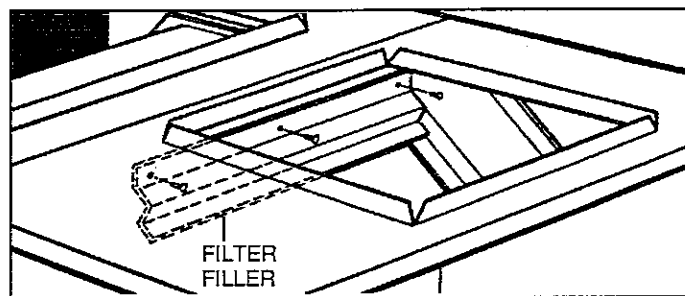

SMOKE PIPE INSTALLATION (NOT SUPPLIED)

Clearances to combustible materials (i.e. paneling, ceiling tile, sheet rock, plaster, draperies, casements or wood trim, etc.) will vary with the type of flue connection used. Be sure to maintain the specified clearances for your type of installation.

TYPE OF FLUE CONNECTION	REQUIRED CLEARANCE
24 Gauge or Heavier Single Wall Stainless Steel or Black Pipe	18"
Double Wall Stainless Steel	6"
Class A All-Fuel or Equivalent	2"

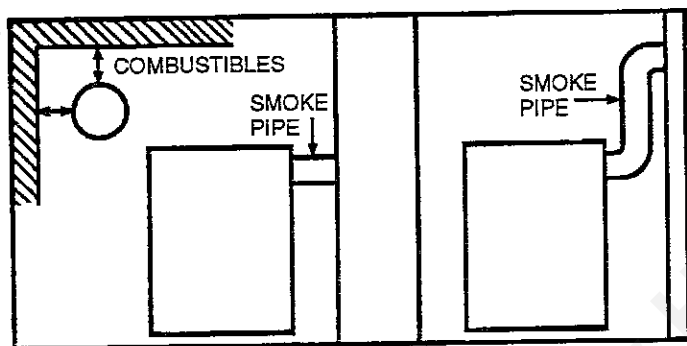

According to NFPA standards, single wall stove pipes can be within 9" of combustibles, provided an approved fire retardant material, covered with 28 gauge metal, spaced out 1" on non combustible spacers, is utilized. See illustration.

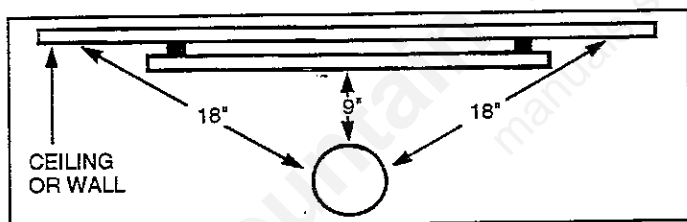

When using a Class A or double wall flue pipe connection, follow the manufacturer's instructions.

When constructing a single wall smoke pipe, the following guidelines must be observed.

1. The smoke pipe should be 24 gauge or heavier stainless steel or black pipe.
2. Secure all joints with three #8 screws.
3. If the smoke pipe must pass through a wall, an approved insulated or ventilated thimble, at least three times the diameter of the smoke pipe must be used. (i.e. a 6" diameter smoke pipe needs an 18" thimble).
4. The smoke pipe should not be used as a chimney.

IMPORTANT INFORMATION FOR ALL SMOKE PIPES

The smoke pipe must be constructed and installed so that it maintains clearances, keeps condensation and creosote within the pipe, and is capable of withstanding a two to three thousand degree chimney fire.

1. The smoke pipe should slant down toward the furnace a minimum of 1/4" to the foot. At no time should the pipe turn downward toward the chimney or run horizontal.
2. There should be no more than two 90 degree elbows.
3. The smoke pipe should never be longer than six feet. If it is absolutely necessary to make a run of more than six feet (not recommended) use extra support brackets every 3 feet.
4. The smoke pipe should never be reduced to a smaller size than flue opening on the furnace.
5. The smoke pipe should not block the flue of the chimney or extend into it in any way.
6. A good airtight thimble should be used to hold the smoke pipe in the chimney. It should be constructed so the smoke pipe can be removed for cleaning.
7. The smoke pipe should not leave the heated portion of the building to reach the chimney.
8. The smoke pipe should not pass from one story to the next before entering the chimney. Nor should it pass through any closed or enclosed space.
9. Heat reclaimers should not be installed or used in the smoke pipe.
10. The smoke pipe should not be located near or in a walk way or well traveled area.
11. All male ends of smoke pipe should run or point towards the furnace.

DRAFT REGULATOR INSTALLATION (Not supplied)

The draft regulator should be installed as close to the furnace as possible. It must be installed in the same room as the furnace and be no less than 18" from combustibles. The following diagrams show acceptable placement.

BEST LOCATIONS FOR BAROMETRIC DRAFT

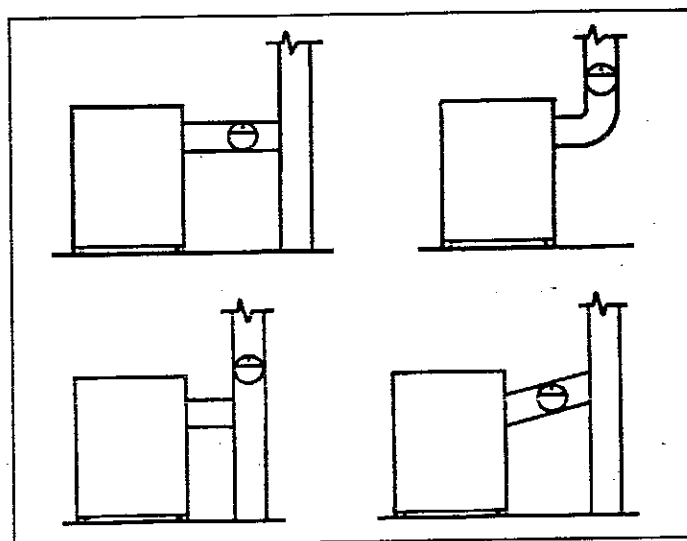

The draft regulator is designed to maintain a very precise draft setting, so it is important to use care when installing it.

INSTALLING DRAFT REGULATOR ON SMOKE PIPE OF EQUAL SIZE (NOT SUPPLIED)

1. Bend out the ears on the front corners of the collar and draw together with nut and bolt.
2. Join the rest of the collar together with bolts or screws supplied.
3. Place contoured end of collar against smoke pipe in desired mounting location.
4. Scribe outline of collar on smoke pipe.
5. Cut a hole in the smoke pipe approximately 1/2" smaller than the scribed outline.
6. With a tinsnips, cut a series of slits all the way around the cutout, extend from the edge of the cutout to the scribed outline.
7. Strap the collar to the smoke pipe with associated hardware. Reaching inside, bend the tabs out against the collar.

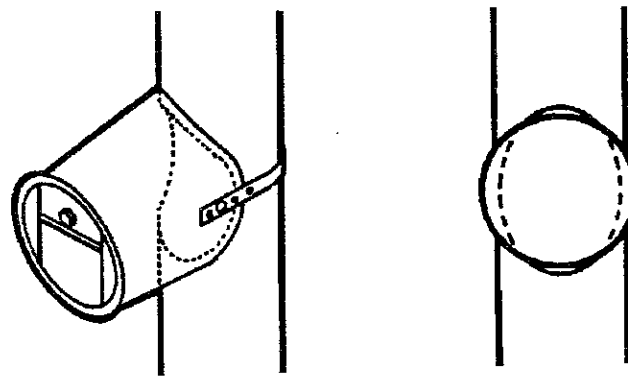

Complete rest of installation as described above

DUCTWORK

Installation of warm and cold air ductwork should conform to NFPA Standard 90B. Use metal ducts only, making sure that they are large enough to handle gravity air flow in the event of a power or furnace fan failure.

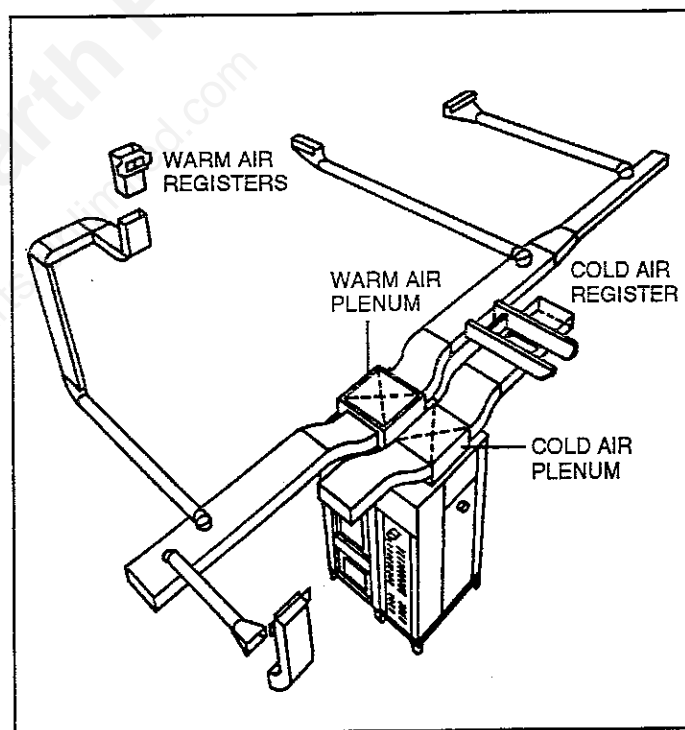

NOTE: If the gauge of the smoke pipe is too heavy to bend out, the opening in the smoke pipe should simply be cut so that it is nearly as large as the collar's diameter.

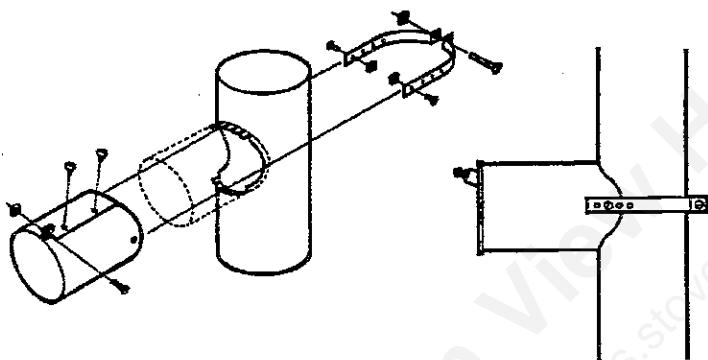

INSTALLING THE DRAFT REGULATOR ON SMALLER OR LARGER SMOKE PIPES

For larger smoke pipes, simply force the collar against the pipe so it will take the shape of the pipe. Scribe outline on the smoke pipe and complete installation as previously described.

If the collar is larger than the smoke pipe, it should be pre-shaped to make a tight fit with the smoke pipe. Place the draft regulator in the squared off end of the collar to keep the collar round. Squeeze other end of the collar in the direction of the smoke pipe until you have an oval that tightly fits smoke pipe.

OIL BURNER INSTALLATION

GUN ASSEMBLY ADJUSTMENT

The tip of the nozzle should be located 7/8" behind the front face of the burner air cone.

To set nozzle position, adjust the gun assembly in the slot on the side of the fan housing by loosening screw holding slot cover in place.

MOUNTING BURNER:

1. Make certain hole in side of pyrolite chamber is aligned with hole in blast tube.
2. Place gasket on burner mounting flange.
3. Insert burner tube through opening in fire wall and into blast tube. Be sure burner mounting flange is tight against front of furnace.
4. Secure flange with three 3/8" x 1" bolts and lockwashers and nuts.

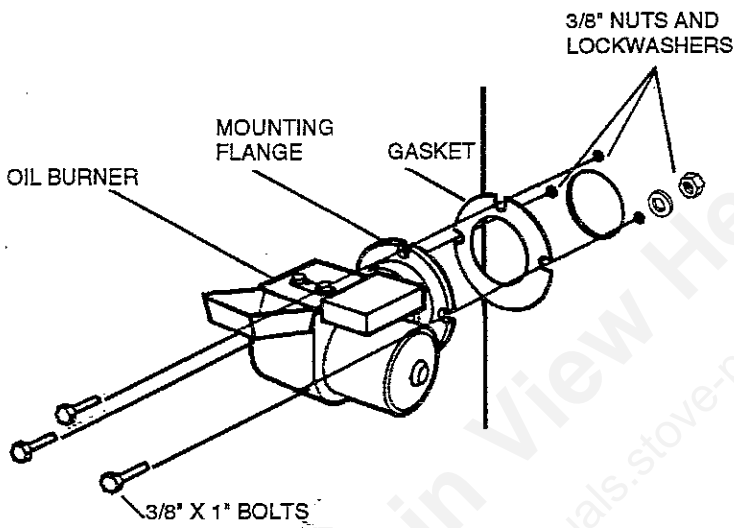

GAS BURNER INSTALLATION

NOTE: See furnace specifications (page 1) for other allowable sizes. To convert to L/P gas - see manufacturers instructions packed with the burner.

MOUNTING BURNER:

1. Make sure hole in side of pyrolite chamber lines up with hole in blast tube.
2. Place gasket on burner mounting flange.
3. Insert burner air tube into opening in firewall and into blast tube so that burner mounting flange is tight against front of furnace. (End of air tube should be flush with inside of pyrolite chamber.)
4. Secure flange with three 3/8" bolts and lockwashers and nuts.

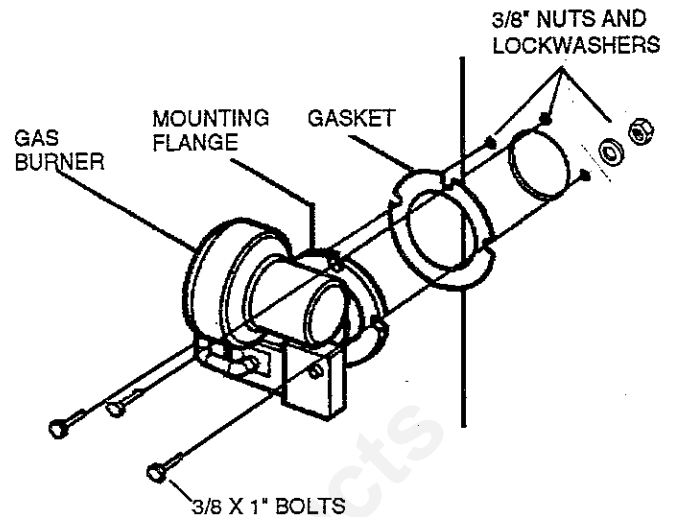

FUEL OIL TANKS AND LINES

Fuel tanks and fuel lines must be installed in accordance with requirements of NFPA 31.

If the fuel lines are under 30' in length, the use of 3/8" O.D. copper tube is satisfactory. For lines over 30' in length, 1/2" O.D. is recommended. Use good flare connections on the fuel lines and if possible, avoid splicing the line and using overhead lines. Avoid kinks and traps and do not fasten lines to floor joists, sills, or girders. Support fuel lines when possible with sound absorbing devices.

CAUTIONS: Never use tube smaller than 3/8" O.D. Never use a splice or joint underground.

An enclosed fuel tank with a capacity of more than 10 gallons must be located at least 5 ft. horizontally from any flame producing appliance or other source of fire.

SINGLE LINE SYSTEM

Use a single line hook-up only when the outlet on the fuel tank is higher than the inlet on the burner (when fuel does not have to be lifted from the tank to the burner).

TWO LINE SYSTEM

Use a dual line system when the fuel must be lifted from the tank to the burner. For tanks buried outside, install a supply line, called a suction line, from the tank to the burner. This line should extend down to within a few inches of the bottom of the tank. A return line should be installed from the burner back to the tank.

High pressure oil burners require the use of a fuel filter to be installed in accordance with local codes. New filter inserts should be installed annually or as required. Always use the new gasket supplied with filter insert. The top of the filter should be carefully tightened, making sure the gasket fits properly.

AIR VENT MUST BE ABOVE SNOW LEVEL. VENT MUST BE AT LEAST 2" FROM ANY BUILDING OPENING. FILL PIPE MUST BE AT LEAST 5" FROM ANY BUILDING OPENING.

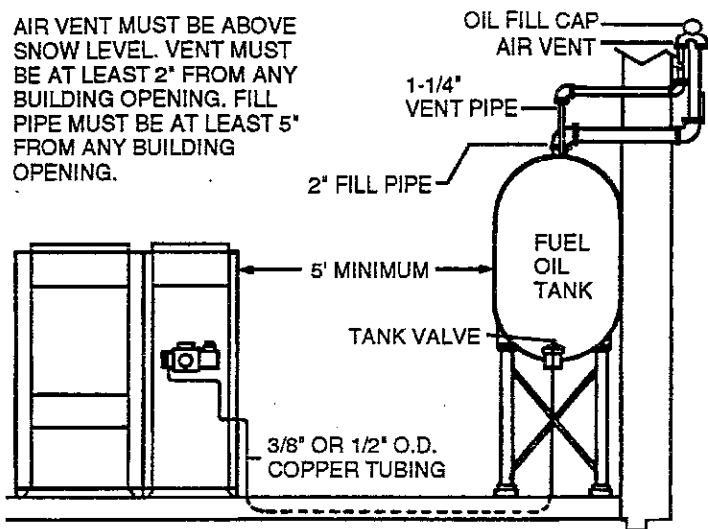

FILL AND VENT PIPES

Fuel tanks must be equipped with a fill pipe and a vent pipe. A fill pipe with a water-tight cap should be located in a convenient place for filling. The vent pipe should be 1-1/4" diameter. The vent should extend outdoors and use an approved vent hood.

GAS PIPING

Installation of gas piping must comply with local codes. Follow the national fuel gas code ANSI-2 223.1 if no local code exists. A sediment trap or drip leg must be used in the supply line to the burner.

A union must be installed in the gas line adjacent to, and upstream from the control manifold and downstream from the manual main shut-off valve.

A manual shut-off valve must be installed in the supply line with a 1/8" N.P.T. plugged tapping for test gauge connection.

A separate gas supply line should run directly from the meter to the burner.

The piping should be installed so as not to weaken the building structure and should not be supported by other pipes. Securely support the pipe with pipe hooks, bands, hangers or straps.

AIR VENT MUST BE AT LEAST 2" FROM ANY BUILDING OPENING. FILL PIPE MUST BE AT LEAST 5" FROM ANY BUILDING OPENING.

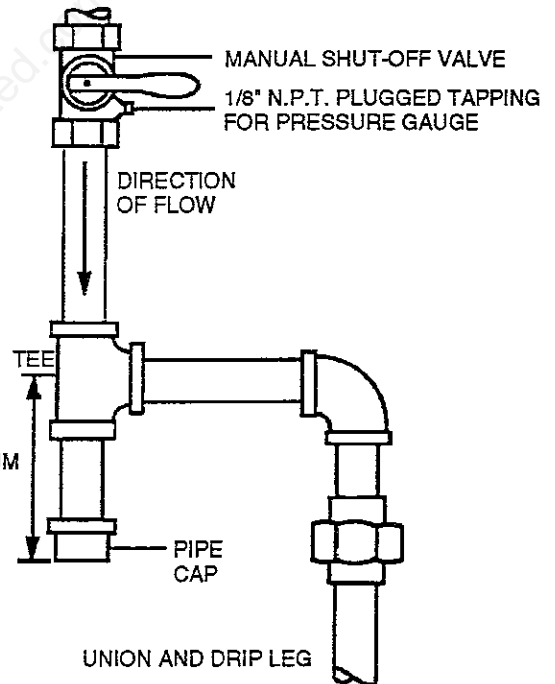
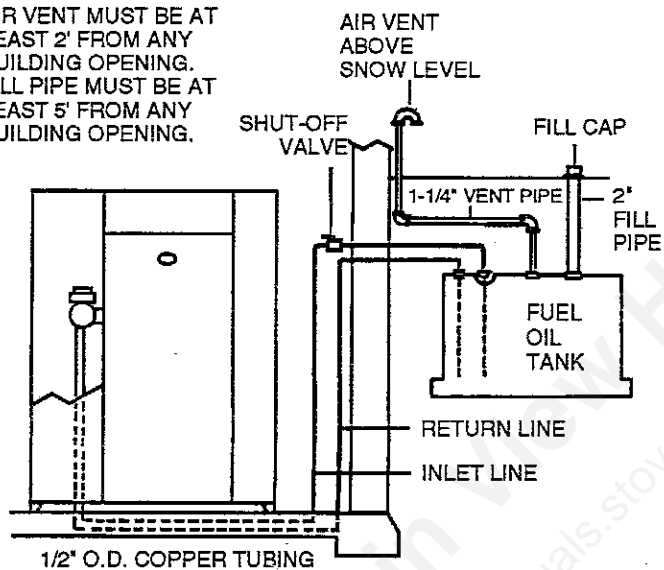

New pipe should be used to ensure that the piping is durable, gas tight and free from any defects. Cast iron fittings or aluminum tubing should not be used for the main gas circuit. Use joint compounds (pipe dope) sparingly on male threads only and make sure it is approved for all gases. Butt or lap welded pipe should not be bent.

The gas piping should be installed so that it prevents an accumulation of condensation and is protected against freezing. A horizontal pipe should be pitched so that it angles down towards the meter without sagging. Do not run the pipe through air ducts or clothes chutes.

Check all piping and meter connections for leaks. Once tests are complete, purge the system of air and relight pilots on all other gas appliances.

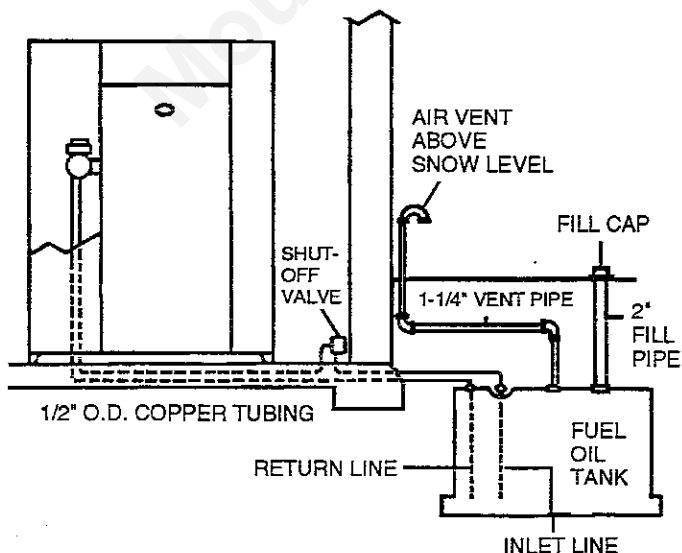

Use the following table to determine the size pipe to be used from the meter to the burner.

PIPE CAPACITY TABLE

Length of Pipe in Feet	Nominal Diameter of Pipe in Inches				
	3/4	1	1-1/4	1-1/2	2
	Capacity—Cu. Ft. Per Hr. with a 0.6 Sp. Gr. Gas and Press. Drop 0.3 in. Water Col.				
15	172	345	750		
30	120	241	535	850	
45	99	199	435	700	
60	86	173	380	610	
75	77	155	345	545	
90	70	141	310	490	
105	65	131	285	450	920
120		120	270	420	860
150		109	242	380	780
180		100	225	350	720

COMBUSTION AIR

The fire in the furnace uses oxygen and needs a continuous supply. The air in a house contains only enough oxygen to supply the burner for a limited time. Therefore, outside air must enter the house to replace the supply used by the burner. This will insure proper combustion and a safe oxygen level. Without adequate combustion air, a lack of air pressure could occur in the home, causing cold air to be drawn in around door and window openings. It will also cause incomplete combustion of wood, increasing creosote buildup in the heat exchanger, flue pipe and chimney. That buildup will cause more heat to be lost up the chimney and less to be available to the heating distribution system.

CAUTION: Do not install this furnace unless proper combustion air is provided according to the following instructions.

FURNACE LOCATED IN CONFINED AREA

When the furnace is located in a utility room, 2 open grills should be installed on a wall or door opening to the rest of the house. Locate one near the floor to provide combustion air, and the other opening near the ceiling for ventilation. Each grill must have one square inch open area per 1,000 BTU/HR total input rating of all appliances located in the utility room.

The model 150 is rated at 150,000 BTU/HR. Model 110 is rated at 115,000 BTU/HR. To figure the number of sq. in. of open area needed, divide BTU rating by 1000. A metal louvered grill has about 60% open area, so to figure actual size of grills required, divide number of sq. in. of open space by 60%. The width of the opening should be twice the height.

EXAMPLE (Model 150): $150,000 \div 1000 = 150$ sq. in.
 $150 \div 60\% = 250$ sq. in.

IMPORTANT: A return air duct, the same size as the other grills, should be connected to the cold air return plenum of the furnace and run to the outside of the confined space.

INSTALLATION OF FRESH AIR DUCT

Install a duct or pipe that brings outside air to a point near the wood/coal burner. The duct may open directly to the outside of the structure or to a ventilated attic or crawl space. The duct opening should have a net free area of 1 sq. inch per 5,000 BTU input per hour. Screen or metal louvers should be used to prevent anything from entering the duct from outside.

The following chart shows acceptable duct sizes for use with both the model 150 and 110 Multifuel Furnace.

1/4" Mesh Screen
 7" Round
 4" x 10" Rectangular

Metal Louver
 8" Round
 5" x 10" Rectangular

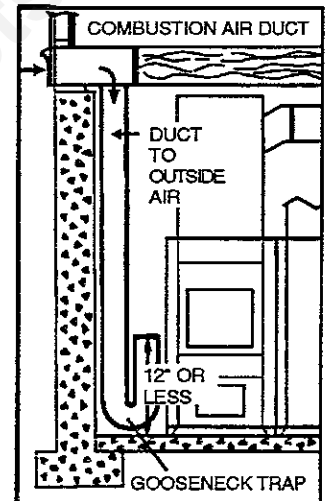
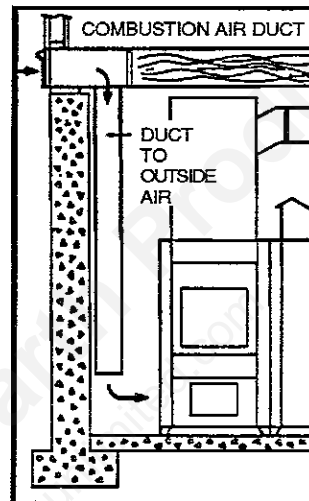

ELECTRIC WIRING

All electric wiring should be done according to the National Electrical Code and the legally authorized code for the area where the furnace is being installed. The circuit protection device should be at an accessible location near the furnace. Wire no lighter than No. 14 should be used in the furnace power supply circuit. The furnace operates on 120 volts, 60 cycle 1-phase alternating current. The individual circuit protection device should be rated at 20 amps.

CAUTION: Turn off electric power at fuse or breaker box, before making any power connections.

WIRING DIAGRAM

ELECTRICAL WIRING SHOULD ONLY BE PERFORMED BY A QUALIFIED ELECTRICIAN.

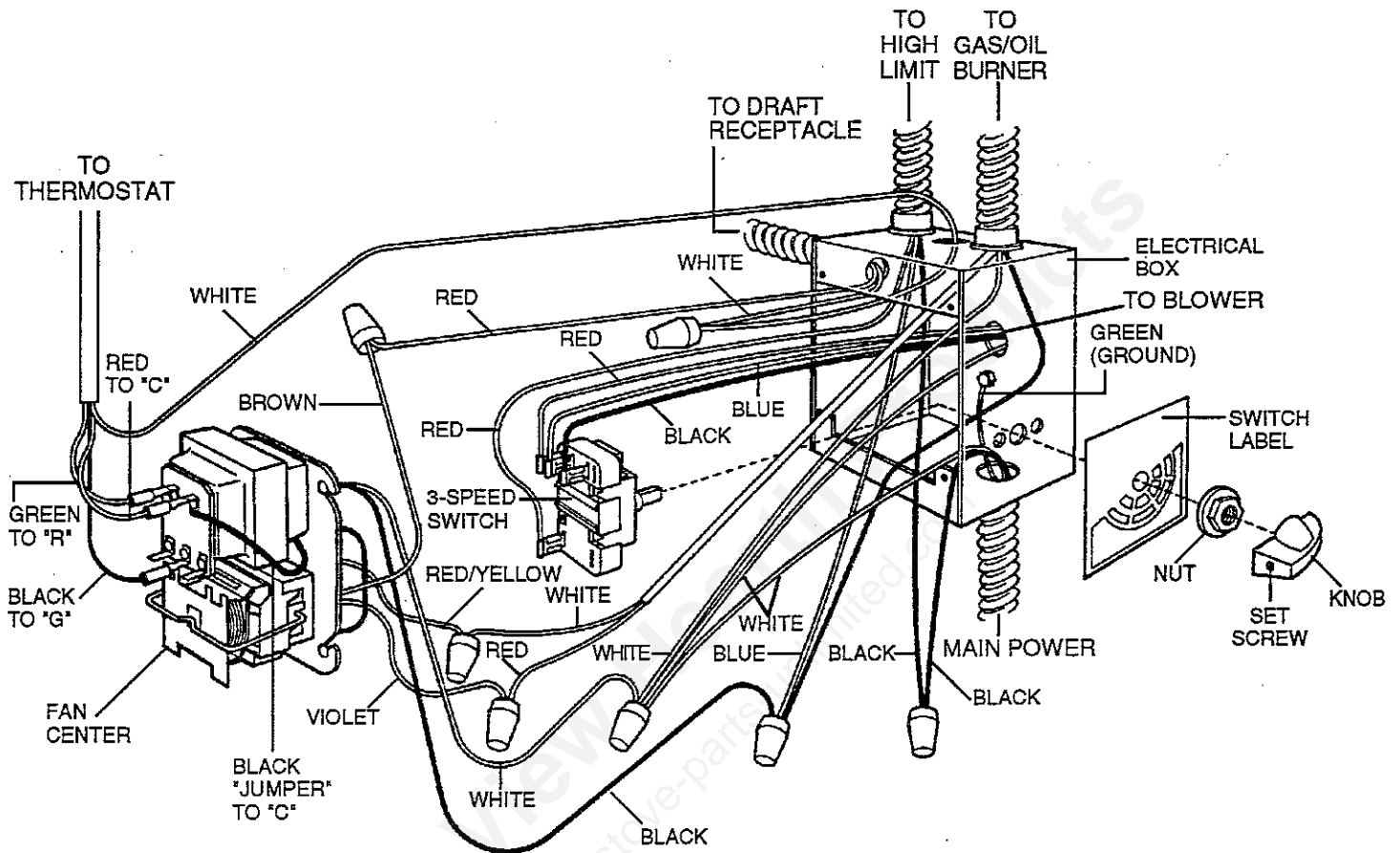

BACK OF FAN CENTER

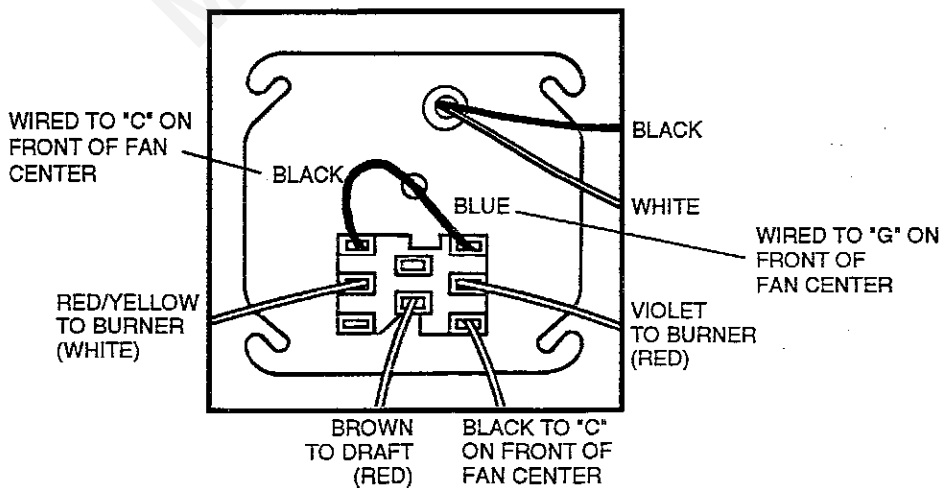

BLOWER SPEED SWITCH

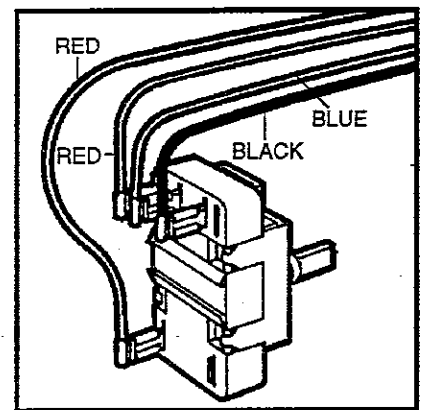

WIRING DIAGRAM

ELECTRICAL WIRING SHOULD ONLY BE PERFORMED BY A QUALIFIED ELECTRICIAN.

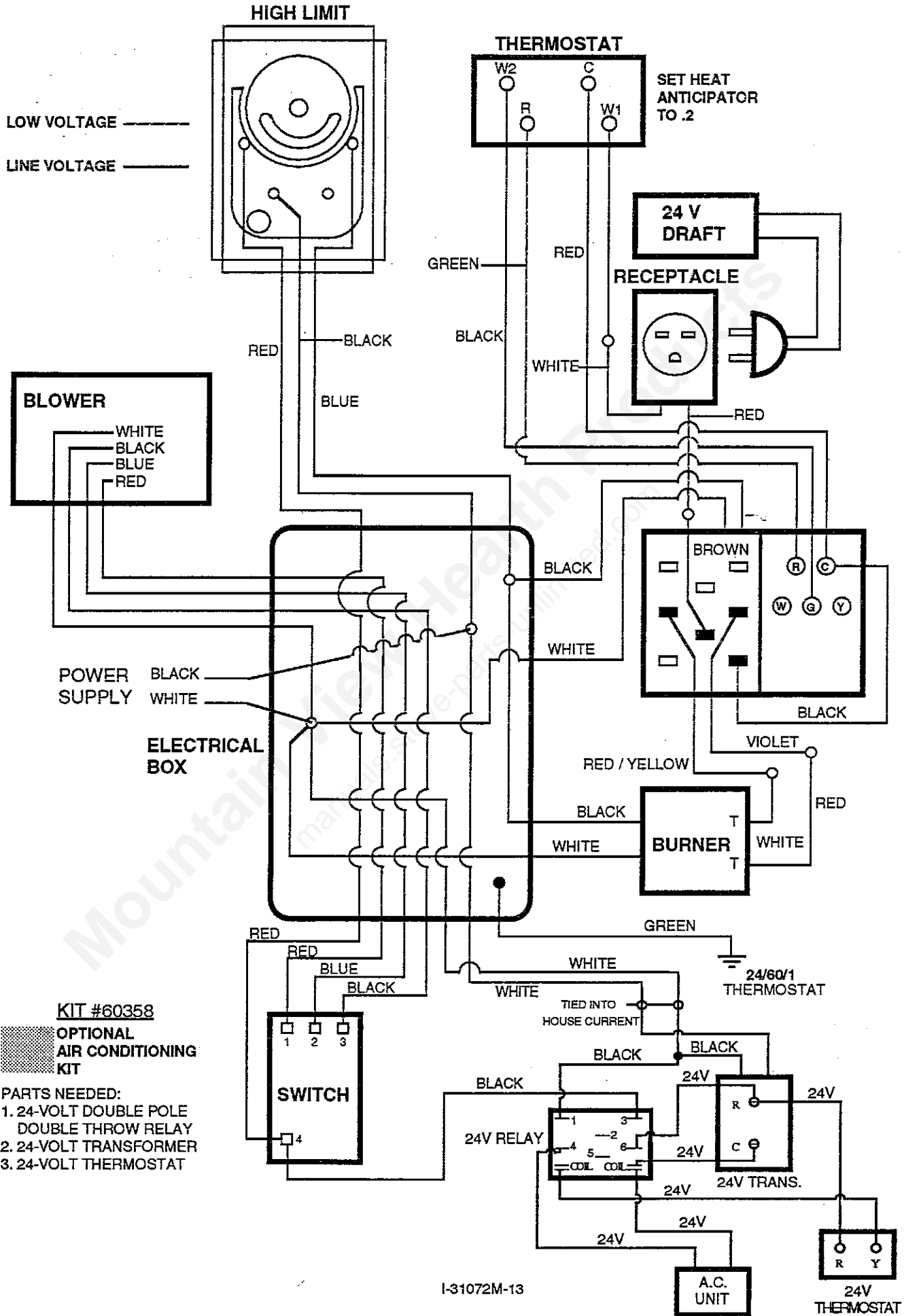

KIT #60358

OPTIONAL AIR CONDITIONING KIT

PARTS NEEDED:

1. 24-VOLT DOUBLE POLE DOUBLE THROW RELAY
2. 24-VOLT TRANSFORMER
3. 24-VOLT THERMOSTAT

ELECTRICAL INSTALLATION

1. Mount the 4" x 4" F.A.D. (junction box) on the 7/8" diameter hole on the front of firewall with clamp connector and at least one #8 tek screw.
2. Feed the blower motor lead wires through the connector. Secure wires with connector clamp and connect leads with spade terminals.

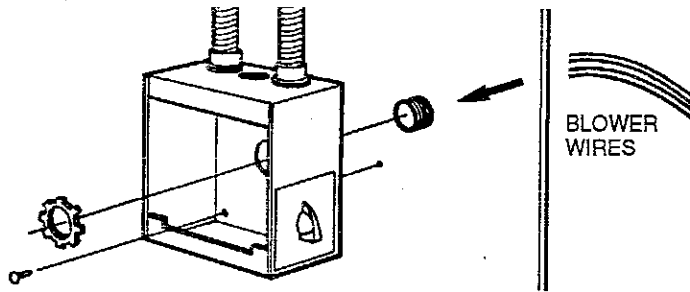

3. Mount 2" x 4" receptacle box to lower left front of air chamber using 2 screws provided.
4. Using prewired flexible conduit provided, attach designated wires to gas or oil burner electrical box.

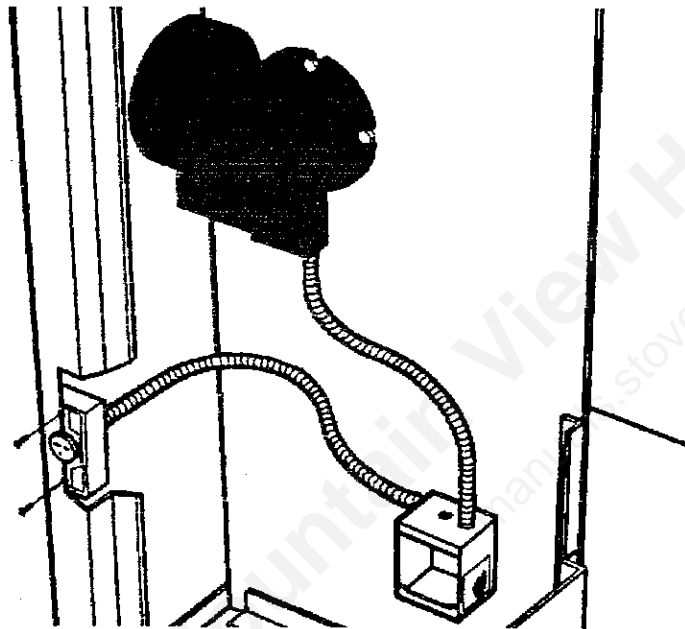

INSTALLING HIGH LIMIT CONTROL

1. Mark a spot on the front of the warm air plenum 12" up from the top of the furnace and 9" in from the right side of the plenum. Drill a 7/8" hole.
2. Insert limit element tube through hole and punch holes for mounting #8 tek screws. Secure base to plenum.
3. Run prewired flexible conduit from high limit, through 7/8" predrilled hole in top left corner of air chamber. Connect conduit to 4" x 4" junction box and wire per schematic.

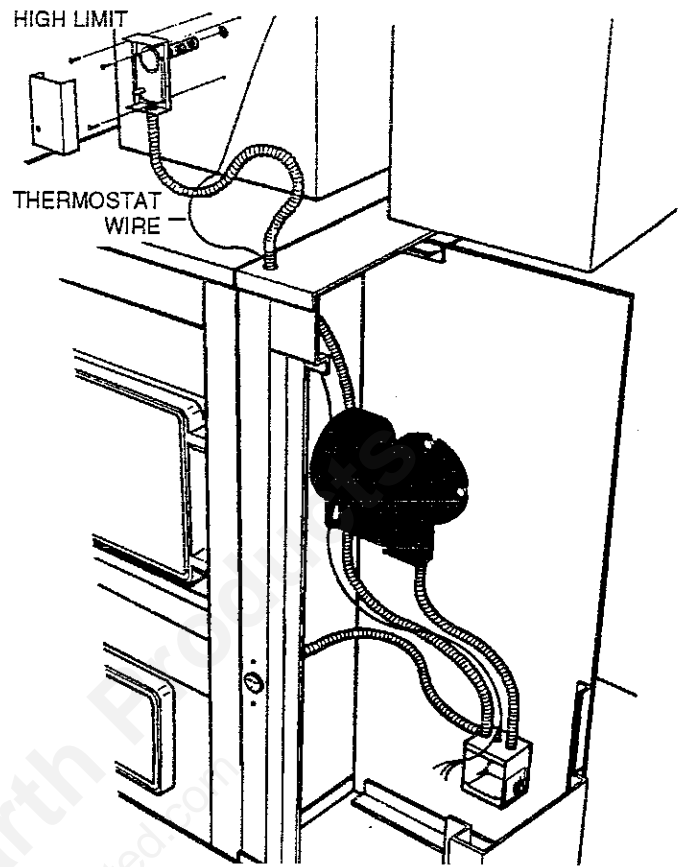

HIGH LIMIT CONTROL SETTING

The fan control is pre-set to turn on the distribution blower at 150 degrees fahrenheit and off at 100 degrees fahrenheit. Do not change these settings. Lower settings may result in increased build-up of creosote in the flue.

MOUNTING THERMOSTAT AND SUB-BASE

Thermostat must be mounted on a centrally located interior wall away from direct sunlight and drafts and approximately 5' from the floor.

1. Run four thermostat wires from furnace to location selected. (Not supplied.)
2. Feed the wires thru hole in center of thermostat base and place base against wall.
3. Using a level on the top of base, mark mounting holes on wall.
4. Punch or drill holes in wall and mount thermostat base.
5. Recheck level and tighten.

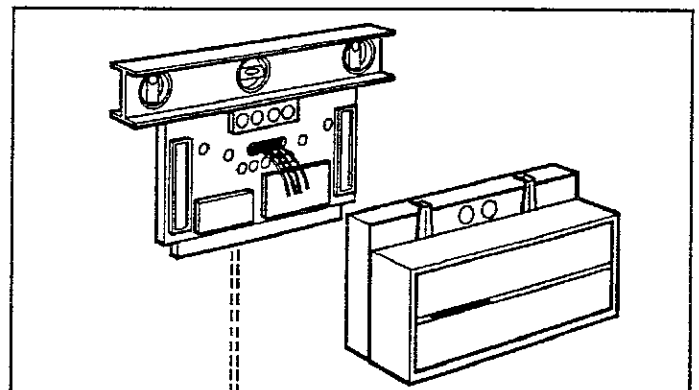

- Connect wires to proper terminals indicated in wiring diagram.
- Mount the thermostat onto base.
- Set heat anticipator to .2 and attach thermostat cover.

NOTE: Right hand lever on thermostat is wood/coal setting and left hand lever is for oil or gas temperature setting.

MAIN POWER CONNECTION

- Drill 7/8" hole in side of air chamber to accommodate flexible conduit carrying 115 VAC power.
- With Romax connector, join conduit to knockout in bottom of 4" x 4" junction box.
- With wire nuts connect power leads per wiring diagram.
- Mount fan center to face of box.

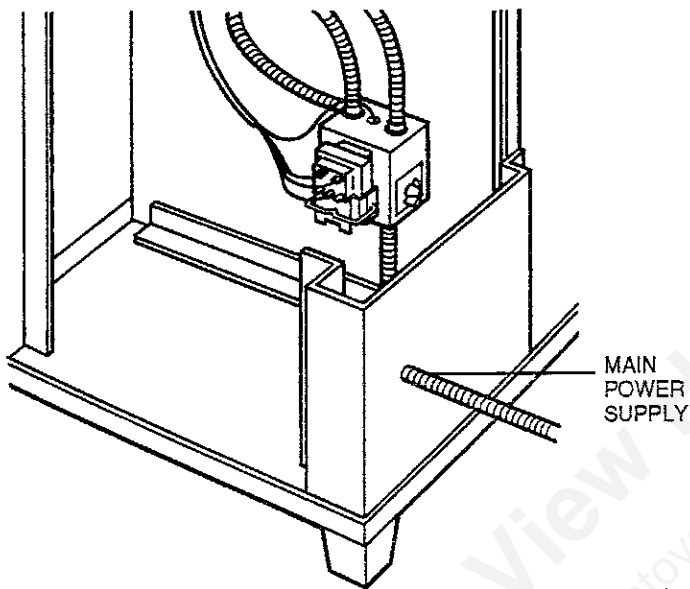

MOUNTING MOTORIZED NATURAL DRAFT

- Using (2) 1/4" x 1" bolts, lock washers and nuts, attach draft to furnace with draft tube clamp.
- Plug draft power cord into receptacle on front of air chamber section.

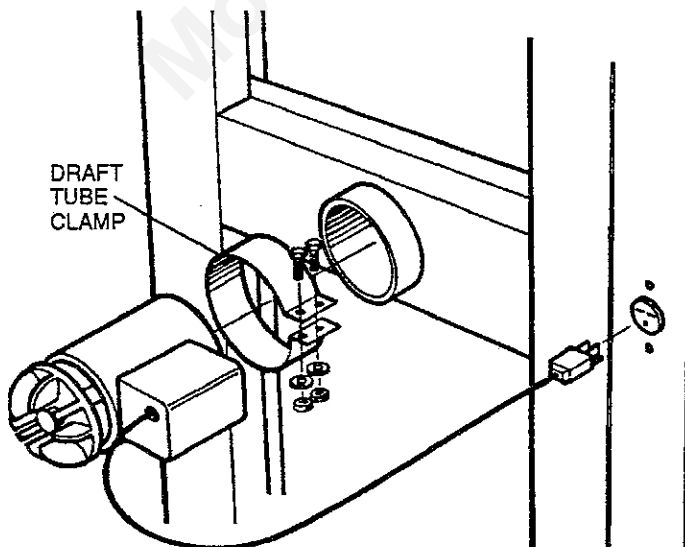

OPERATION

THERMOSTAT SETTING

The combination thermostat provided is two thermostats in one. The controls on the right side regulate the solid fuel section of the furnace and the left side regulates the gas/oil burner. The solid fuel section is intended to be the primary heat source with the gas or oil burner serving as an automatic backup.

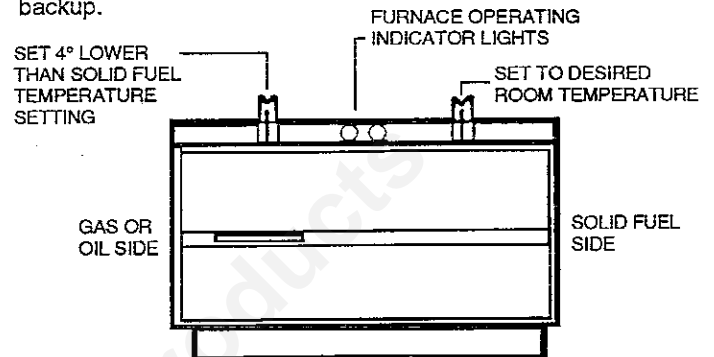

WITH A WOOD/COAL FIRE

When the room temperature drops, the thermostat activates the motorized natural draft which allows combustion air to enter the firebox. This increases the heat output of the furnace activating the high limit control which in turn, starts the furnace blower. Once the thermostat setting is satisfied, the draft damper closes, slowing the fire. When the plenum temperature drops to the high limit control's lower setting, the blower is shut off.

WITHOUT A WOOD/COAL FIRE OR LOW SOLID FUEL SUPPLY

When the room temperature drops, the thermostat will first go to the solid fuel furnace for heat. If there is no fire, or the fuel supply is too low to provide enough heat, the room temperature will continue to drop until the gas/oil setting is reached. At this point, the gas/oil burner will automatically ignite and maintain the room temperature until the wood/coal firebox is reloaded and operating.

(The motorized natural draft is closed when gas or oil burner is operating)

OIL FIRING

- Ensure that there is an adequate amount of fuel oil in the storage tank. If tank is in the basement or buried below the ground, No. 1 fuel oil must be used.
- Fuses or circuit breakers governing the furnace must be operable (damper plate should be closed).
- Oil valve on storage tank should be open.
- Be sure electrodes on burner have been properly spaced and that nozzle is properly sized and has been installed correctly.
- For testing, open fire door and set left hand thermostat control (oil burner) at least 10° higher than room temperature to ensure electrical system is activated.
- If installation has been done correctly, burner should start. If the burner fails to start, recheck all control settings, wiring, primary relay setting and cad cell.

IMPORTANT NOTE: If a single oil line is used, the burner must be purged of air before oil will flow to nozzle. When a return line is used, purging is not necessary, but will speed up the starting procedure. If this is done, the oil flow should be picked up in a minute or less. If the burner does not light within this time, wait for a moment then recycle. If burner still does not start pump pressure may be too low, adjust to 100 p.s.i.

7. Once burner is operating and stack temperature has stabilized, check draft between barometric damper and furnace, adjust to .06" water column.

GAS FIRING (Pilotless Ignition)

Do not attempt to manually light.

To light burner:

1. With thermostat set below room temperature and power to furnace off, turn manual knob on gas valve clockwise to "OFF" position. (damper plate should be closed).

WAIT 5 MINUTES

2. Turn manual knob on gas valve counterclockwise to "ON" position. Turn on power and set thermostat above room temperature.
3. Burner motor will start and run for 30 seconds. The gas valve opens, ignition transformer provides spark and burner will light.
4. If burner fails to light in four seconds the safety control will lock out and shut the gas valve off.
5. Reset the safety control by turning room thermostat below room temperature and back up again or turning off the power supply to the furnace and back on again. The burner will then repeat Step #3.

NOTE: If burner fails to light and sustain flame after three or four tries, turn off valve and call a burner service mechanic.

To shut off:

1. Set thermostat controls to lowest position and turn off power supply.
2. Turn manual knob on gas valve to "OFF" position.

INITIAL PREPARATION FOR WOOD/COAL FIRING

1. Check to see that main electrical circuit for furnace is "on" and that damper plate in motorized draft is closed.
2. Set right hand thermostat control above room temperature to activate draft.
3. Check draft - damper plate should now be open.
4. Place a sheet of newspaper in the firebox and light it, checking to see that there is sufficient chimney draft to pull the smoke out of the firebox.

WARNING: Before placing wood or coal in the fire chamber, set the thermostat control for the gas/oil burner to its lowest setting to ensure that the burner will not ignite during loading. Return the control to its normal position once loading is completed.

CAUTION: Never use gasoline-type lantern fuel, kerosene, charcoal lighter fluid, or similar liquids to start or "freshen up" a fire in the furnace. Keep all such liquids away from the furnace while in use.

To avoid excessive temperatures do not operate with fuel door or ash pan open.

HAND FIRING

WOOD

1. Turn up right hand thermostat control to open motorized damper.
2. Pull the slide baffle rod to the front position.
3. Open the fuel load door and light fire using kindling and several sheets of newspaper, then close the furnace door. The furnace door should remain closed for 5 to 10 minutes in order to establish the fire. If the fire has established, you are ready to load the furnace.
4. Load the furnace, close the load door and push the slide baffle rod to rear.
5. The motorized natural draft cycles on demand from the wall thermostat. Set the right hand thermostat control at least four degrees higher than the left side. During operation, the motorized natural draft opens and closes as heat is required.

CAUTION: To prevent flame and smoke spillage when adding wood, the slide baffle must be pulled out and the fuel door must be cracked for 10 seconds before being fully opened.

Do not overfire your furnace! After you have become familiar with its operation, you should know how much wood to use.

COAL

Anthracite (hard coal) or bituminous (soft coal), ranging in size from 1" to 3", may be used in this furnace. Smaller pieces are recommended, since they ignite more easily and uniformly. Bituminous coal creates more dust in handling and produces more smoke and soot when burned at a slow rate. It may also have a higher sulfur content.

TO START A COAL FIRE:

1. Turn up solid fuel side of thermostat to open the motorized draft damper. Pull slide baffle forward.
2. Place a small amount of crumpled paper and a couple handfuls of dry kindling wood 3/4" in thickness on top of the paper.
3. Ignite the paper and wood. After it is burning briskly, add a thin layer of coal. Once coal is burning, gradually add for coal until coal is about 6" deep. When adding fresh coal, NEVER completely cover the live coals. Draw the top red coals forward and add fresh coal to the rear of the firebox.

IMPORTANT: Never load coal above top of the first row of firebrick.

4. Once coal fire is well established, push in slide baffle and adjust thermostat to desired setting.

MAINTAINING A COAL FIRE

Bituminous coal should be built up into a cone shape once the fire is established. When adding more coal, slightly break-up the cone with a poker. Do not mix the coal, since this will increase the chance of forming clinkers.

CAUTION: When adding coal to an existing fire, first pull out the slide baffle and "crack" the fuel door for ten seconds before opening fully.

USING THE SHAKER GRATE

"Work" the shaker grate handle only enough to remove excess ash accumulation. An ash layer 1" to 2" thick should be left on the grates. This will prevent live coals from falling into the ash pan and help protect the grates from overheating. Grates, typically, only need shaking once or twice a day. Do not allow ash to accumulate in the ash pan so that it comes in contact with the grates. This can cut off combustion air and increase the possibility of damage to the grates.

BANKING COAL OVERNIGHT

ANTHRACITE - Pile up the coal towards the back of the firebox, sloping it towards the fire door. Leave some burning coals uncovered at the front.

BITUMINOUS - Shake the coal bed and add coal, forming a cone in the center. Allow the volatiles to burn off before closing the fire door.

ASH REMOVAL (WOOD AND COAL)

CAUTION: Ashes should be placed in a metal container with a tight fitting lid. The closed container of ashes should be placed on a non-combustible floor or on the ground well away from all combustible materials pending final disposal. If the ashes are disposed of by burial in soil or otherwise locally dispersed, they should be retained in the closed container until a cinders have thoroughly cooled. Coal ashes should not be spread onto a garden, because the minerals left in coal could harm plant life.

SOLID FUEL STORAGE

Wood should be properly stacked and kept dry. Coal may be stored inside or outside. The storage area should be clear of other combustibles such as paper, wood, leaves or rags. Protect the coal from rain and snow. Do not pile wet coal on dry. The coal storage area should be an area that is no warmer than 75° F.

CARE AND MAINTENANCE

CAUTION: Before performing any maintenance, be sure electrical power supply is turned off.

AT THE BEGINNING OF THE HEATING SEASON

1. Have a qualified heating specialist inspect and service gas or oil burner, electrical system and fuel supply system.
2. The oil burner nozzle and oil tank filter should be replaced annually. The ignition system should be carefully checked.
3. Burner motors with sleeve type bearings should be oiled once a year with 6 drops of SAE 20 oil. Ball bearing type motors normally do not require oiling. The motor nameplate indicates the bearing type. **DO NOT OVER OIL.**
4. Thoroughly clean the chimney and flue pipe. Use a stiff steel brush of the proper size and shape for your chimney. Start at the top of the chimney and work the brush downward (adding extensions as necessary) until the full length of the chimney has been cleaned. The debris will fall to the bottom of the chimney where it can be removed through

the cleanout door. The smoke pipe and chimney connector should be disassembled and cleaned of soot and creosote. A properly maintained chimney is essential to reducing the risk of a chimney fire.

5. Clean the inside of the firechamber and secondary heat chamber removing soot and creosote. Soot acts as an insulator and reduces the efficiency of the furnace. The high efficiency pyrolite liner in the firepot normally does not require cleaning. If cleaning appears necessary, use caution so as not to damage its surface.
6. Clean blower fan and motor of dust and dirt.

DURING THE HEATING SEASON

1. Change or clean furnace filter monthly.
2. If blower motor is equipped with fill holes, oil every 90 days with a few drops of 30 SAE oil.
3. Regularly inspect the chimney and smoke pipe for creosote or soot build-up. If excessive, clean promptly.
4. Remove soot and creosote from the secondary heat exchanger monthly.

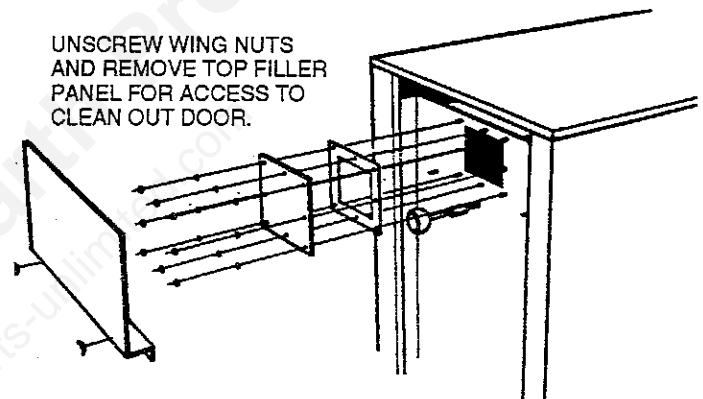

(Clean with wire brush or scraper. Creosote can be left to burn.)

5. Check that the fuel loading door fits tightly. Check for deterioration of the fiber rope, seal and replace as necessary.

AT THE END OF THE HEATING SEASON

1. Shut off electric power for furnace.
2. Clean firebox, secondary heat chamber and ash pan. Lightly coat inside surfaces with motor oil to prevent rust.
3. If using an oil burner, remove and clean oil strainer. Close valve on suction line.
4. Keep oil storage tank filled to prevent the water condensation. The tank should be cleaned every 2 to 3 years to remove water and sediment.

ADDITIONAL OPERATING NOTES

1. Do not burn garbage, plastics, gasoline, drain oil or other flammable liquids. Plastics, when burned, form hydrofluoric and hydrochloric acids which will damage and destroy your furnace pipe and chimney. The burning of trash or oil can result in an extremely hot fire and is sometimes a cause of chimney fires. **NEVER BURN GREEN WOOD OR TIRES.**
2. It is not recommended, burning solid fuel in the Tri-Star furnace in the fall and late spring, since the firebox cannot be kept hot enough (without overheating you home) to burn gases. Slow fires can cause excessive creosote build-up in smoke pipe, chimney and firebox.

3. In the event of a power failure, you may operate the Tri-Star Solid Fuel Furnace for gravity heating, provided the air filter and air conditioning coil (if present) is removed.
4. Equip your home with fire extinguishers and smoke detectors appropriately located.

In event of chimney fire, shut all draft controls and call your fire department immediately. Alert everyone in the house. If the fire is still burning vigorously, throw baking soda into firebox or discharge a fire extinguisher into the firebox. After chimney fire is over, completely inspect system for damage before further use.

NOTE: For further information on using your Tri-Star safely, obtain a copy of the National Fire Protection Association publication "Using Coal and Wood Stoves Safely." NFPA No. NW-8-1974. The address of the NFPA is 470 Atlantic Ave., Boston, Massachusetts 02210.

TROUBLE SHOOTING

1. Problem:

Smoke Puffs from Furnace

Solution:

- A. Check chimney draft. Check for blocked chimney or flue pipe. Use mirror to check chimney clearance.
- B. Check ash pit - if it is too full, empty.
- C. Make sure furnace room is not too airtight.
- D. Make sure all chimney mortar connections are airtight.
- E. Check ash door. Make sure it's airtight.
- F. Check chimney for possible down-draft, caused by taller surrounding trees or objects. Correct with proper chimney vent cap.
- G. Check the possibility of a cold chimney forcing cool gases backward. Remedied by properly insulating chimney with non-combustible liner / non-combustible insulation.
- H. Fuel may be too green.
 - I. Make sure no other fuel burning devices are connected to the chimney impairing the draft.
- J. Check chimney, it should be .04 inches of water column.

2. Problem:

Inadequate Heat Being Delivered to Your Home

Solution:

- A. Check home insulation - is it adequate?
- B. Check installation - is it installed correctly?
- C. Check High Limit Switch.
- D. Cool air inlet may be inadequate, furnace room too airtight, cold air returns too small or blocked.
- E. Your wood fuel may be too low grade. Hardwoods are recommended.
- F. Make sure your hot air duct (and other duct work) is airtight.
- G. Is air to the blower available? Check filter.
- H. Change blower motor switch to a higher speed.
- I. Check heat exchanger for excessive soot.

3. Problem:

Excess Smoke or Flames Coming Out Door When Refueling

Solution:

- A. Wait 10 seconds and open door SLOWLY - then refuel.
- B. Check length of flue pipe to chimney. Your unit should be within six (6) feet of your chimney.
- C. Make sure chimney cap is not close to the top of the chimney.
- D. Check chimney draft - make sure chimney flue pipe is clean and chimney is of adequate height.
- E. Make sure you're not suffocating the fire with excessive amounts of unburned wood or coal.
- F. Slide baffle should be pulled out prior to load door opening.

4. Problem:

Distribution Blower Vibrating

Solution:

- A. Tighten blower wheel to motor shaft.
- B. Check for bad fan bearings.
- C. Oil blower motor.
- D. Replace dirt air filter.

5. Problem:

Distribution Blower Continues To Run or Will Not Run

Solution:

- A. Check high limit switch.
- B. Check to see that blower is properly wired. (See Wiring and Assembly Instructions.)
- C. Check fuse box or power source.

6. Problem:

Draft Damper Will Not Close or Open

Solution:

- A. Check wiring.
- B. Check thermostat or thermostat wire for short.
- C. Make sure thermostat is or is not calling for heat.

7. Problem:

Odor From First Fire

Solution:

- A. The odor from new steel should disappear in a few hours.
- B. If the odor remains, call your dealer immediately. A bad weld can cause a fume leak.

8. Problem:

Excessive Creosote

Solution:

- A. Check the grade of wood you are burning.
- B. Make sure your unit is serviced by its own proper chimney.
- C. Check length of flue pipe and its connections.

- D. Make sure you are burning the smallest, hottest fire to adequately heat your home.
- E. Also see Solutions to Problem one.

GAS/OIL BURNER TROUBLE SHOOTING

1. Problem:

Oil burner ignition failure

Solution:

- A. Find cause of ignition failure. Check for plugged nozzle, dirty electric eye, damaged, or sooted electrodes, plugged oil line or closed valve, low fuel, interrupted electrical power, etc.
- B. Do not try restarting burner if there is an excessive oil accumulation or when the fire chamber is very hot.
- C. After checking system, press reset button on burner control box and burner should start. Only attempt this twice. If burner fails to start, call a heating specialist.

2. Problem:

Gas burner ignition failure

Solution:

- A. Find cause of ignition failure. Check for improperly set fuel and control valves, interrupted electrical power, etc. See Separate burner manual.
- B. If problem cannot be determined call a heating specialist.
- C. With problem corrected follow normal start-up procedure outlined in this manual.

TEST PROCEDURES FOR EFFICIENCY AND PROPER OPTIONS (For Furnace Installer)

IMPORTANT: Set updraft in smoke pipe to .05-.06" water column by adjusting counter weight on draft regulator. Use draft gauge for setting. An improper weight setting will waste fuel, reduce heating efficiency, cause excessive creosote buildup and may result in damage to the heating system.

The following smoke and CO₂ tests can be performed to check furnace efficiency for both solid fuel and oil. Prior to test, check that draft regulator is plumb and level, located in the same room as the furnace, and is close to the unit on a vertical, or up-sloped section of the smoke pipe.

1. Drill 2 holes approximately 1/4" in diameter in the flue pipe between the furnace outlet and the draft regulator.
2. Place a stack thermometer into one of the holes and leave it there throughout the test.
3. Set thermostat high enough so furnace will run long enough for test to be completed. Approximately 15 minutes.
4. Allow unit to run long enough for stack temperature to stabilize.
5. Insert sampling tube of CO₂ tester in hole drilled in flue pipe. Measure percentage of CO₂ in venting smoke and gases. (See instrument manufacturers instructions.)
6. Use efficiency finder chart or stack loss slide rule to determine efficiency. Subtract the room temperature from the stack thermometer reading to come up with the net temperature used in the calculation.

7. Place smoke tester in hole in flue pipe and perform smoke test.
8. The smoke tester filter paper, when compared to the standard should not be greater than #2 and preferably #1 or zero, depending on local requirements or your own service standard.
9. Repeat tests as necessary, adjusting the burner air shutter and draft regulator to achieve the highest efficiency. It is desirable to have a high CO₂ reading and a minimum smoke reading with a low stack temperature.

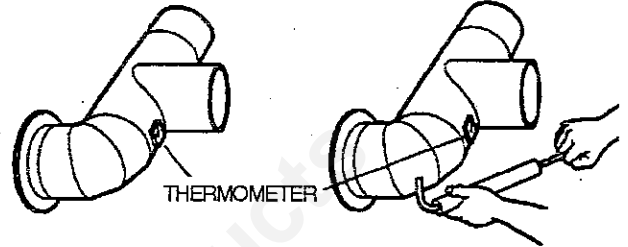

NOTE:
HOLE FOR THERMOMETER
MUST BE 6 TO 8 INCHES
ABOVE THE FLUE PIPE
ELBOW, BUT BELOW THE
DRAFT REGULATOR.

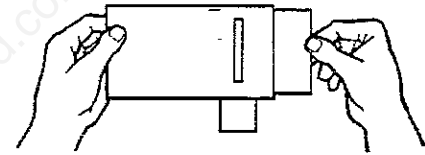
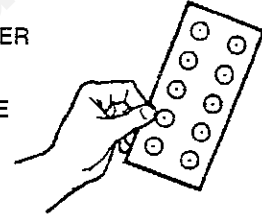

INFORMATION ON SOLID FUELS

TEMPERATURE AT WHICH VARIOUS FUELS IGNITE	
PAPER	350° F
WOOD	435° F
WESTERN LIGNITE COAL LOW VOLATILE	630° F
BITUMINOUS COAL	765° F
HIGH VOLATILE BITUMINOUS COAL	870° F
ANTHRACITE COAL	925° F
Nut size coal weighs approximately 58 lbs. per cu. ft. A storage bin with a size of 4 sq. ft. x 4 ft. high will hold 2 tons.	

HOW VARIOUS TYPES OF WOOD COMPARE TO #2 FUEL OIL AS A SOURCE OF HEAT			
Type of Wood	Cord Weight	BTU's Per Cord	Equivalent Value In Gallons For Fuel Oil
White Pine	1800	17,000,000	120
Aspen	1900	17,500,000	125
Spruce	2100	18,000,000	130
Ash	2900	22,500,000	160
Tamarack	2500	24,000,000	170
Soft Maple	2500	24,000,000	170
Yellow Birch	3000	26,000,000	185
Red Oak	3250	27,000,000	195
Hard Maple	3000	29,000,000	200
Hickory	3600	30,500,000	215

MULTI-FUEL PARTS LIST

MODELS 150 & 110 SOLID FUEL LIST

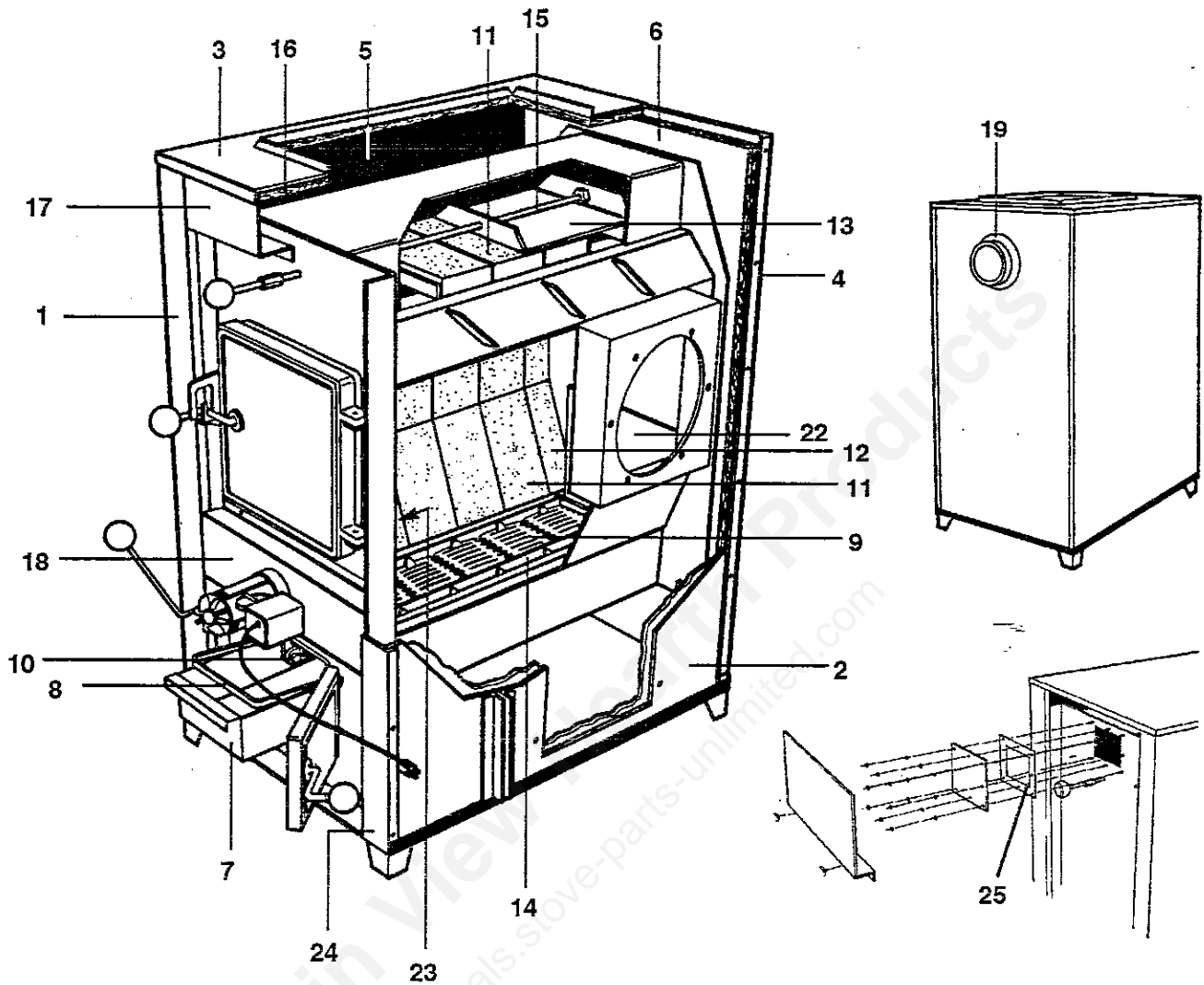

ITEM	DESCRIPTION	MODEL	PART#
1	Left Side	150	1167M
		110	1168M
2	Right Side	150	1177M
		110	1178M
3	Top Side	150	1187M
		110	1188M
4	Back	150	1197M
		110	1198M
		110	1198M
5	Side Insulation	150	9067M
		110	9068M
6	Back Insulation	150	9077M
		110	9078M
7	Ash Pan	150	10471
		110	10456
8	Carrying Handle	150	10571
		110	10556
9	Shaker Grate Section	150-110	51499
10	Grate Bar	150	10671
		110	10656

ITEM	DESCRIPTION	MODEL	PART#
11	Full Brick	150-110	90499
12	Half Brick	150-110	90399
13	Slide Baffle Plate	150-110	1207M
14	Grate Frame Cast (each)	150	50171
		110	51656
15	Slide Baffle Rod	150	10871
		110	10856
16	Top Insulation	150	9087M
		110	9088M
17	Top Filler	150	1217M
		110	1218M
18	Front Filler	150-110	11057
19	Flue Ring	150-110	1117M
22	Back Deflector Cast	150-110	50257
23	Front Deflector Cast	150	51571
		110	50456
24	Front Skin Spacer	150	1227M
		110	1228M
25	Clean-out Gasket	150-110	9137M

MULTI-FUEL PARTS LIST

MODELS 150 & 110 SOLID FUEL SECTION

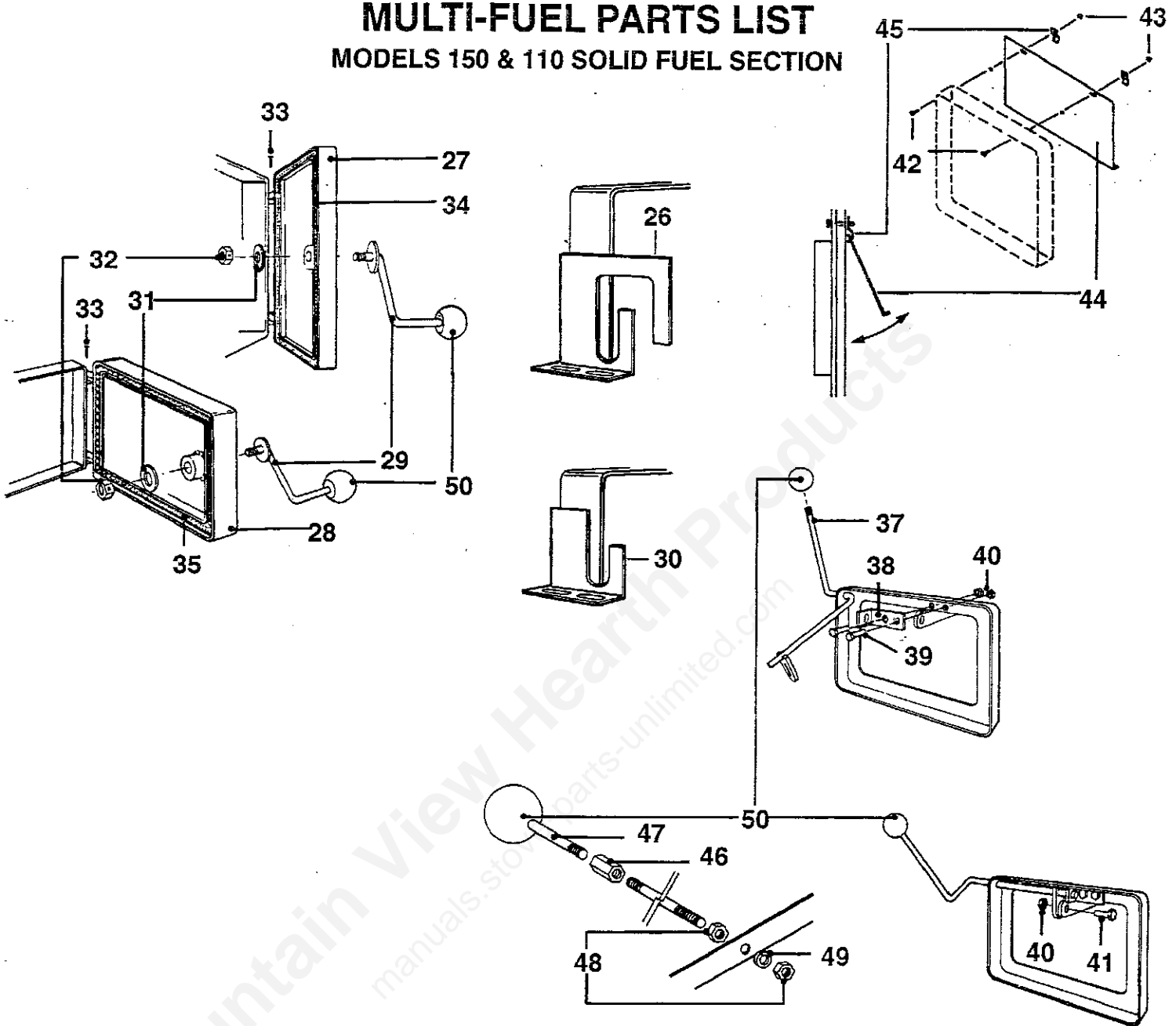

ITEM	DESCRIPTION	PART#
26	Top Safety Latch	13999
27	Fire Door	50899
28	Ash Door	50999
29	Door Latch Handle	14099
30	Ash Door Latch	14299
31	1/2" Flat Washer	21299
32	1/2" Lock Nut	20399
33	5/16" x 1-1/2" Hinge Pin	21399
34	1/2" Rope for Fire Door	91499
35	1/2" Rope for Ash Door	91599
37	Shaker Grate Handle	14799
38	Shaker Handle Angle	14899

ITEM	DESCRIPTION	PART#
39	1/4" x 3/4" Hex Bolt	21499
40	1/4" Lock Nut	21599
41	1/4" x 1" Hex Nut	20099
42	1/4" x 1-1/4" Carriage Bolt	21799
43	1/4" Lock Nut	20199
44	Smoke Door	14499
45	Smoke Door Clip	14599
46	1/2" x 1-1/2" Hex Connector	21899
47	Baffle Rod Extension	14999
48	1/2" Hex Nut	22199
49	1/2" Lock Washer	22299
50	Plastic Knob	91699

MULTI-FUEL PARTS LIST

AIR CHAMBER SECTION

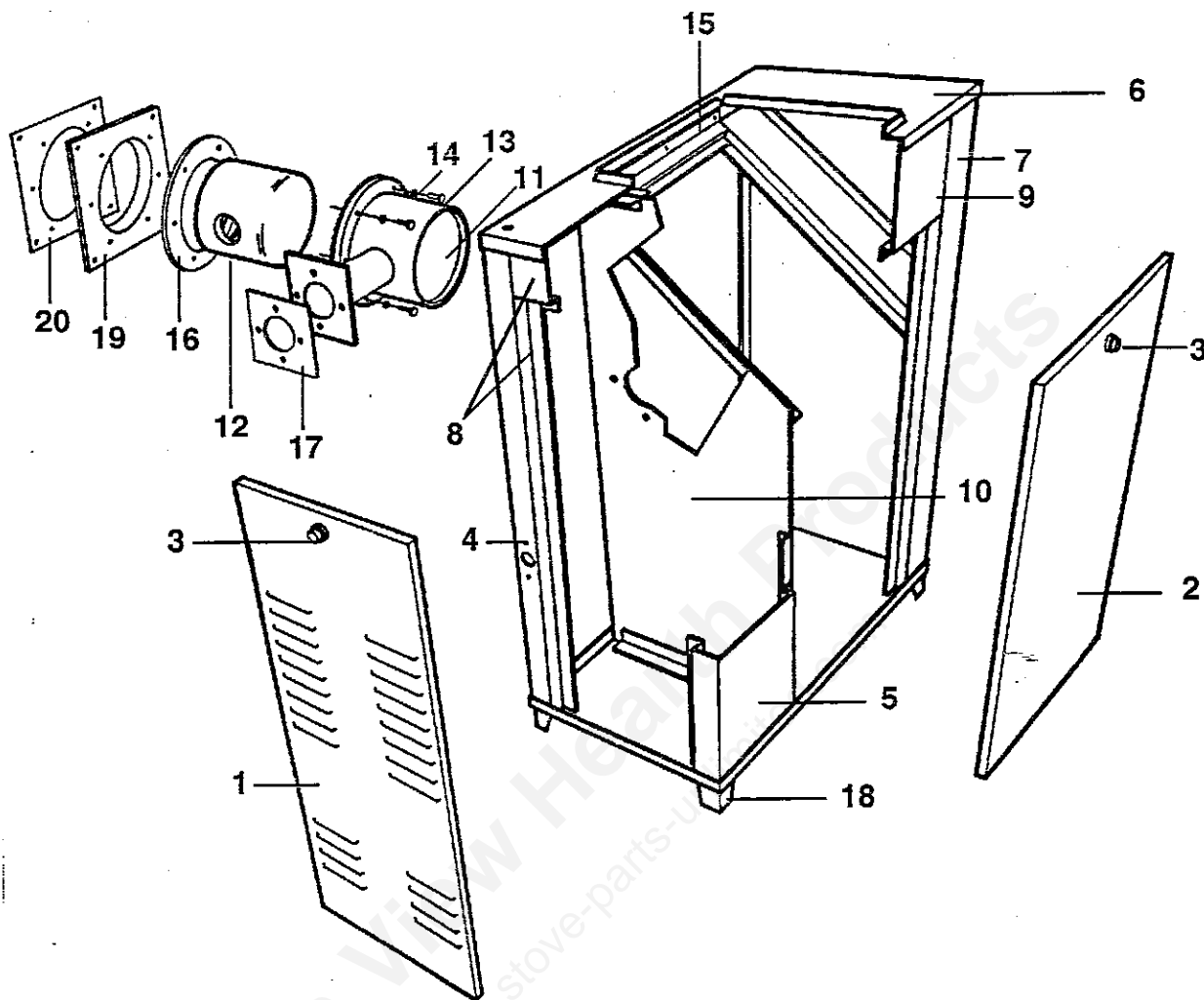

ITEM	DESCRIPTION	MODEL	PART#
1	Front Access Door	150	1237M
		110	1238M
2	Side Access Door	150	1247M
		110	1248M
3	Dummy Lock	150-110	9677M
4	Left Corner	150	1257M
		110	1258M
5	Right Corner	150	1267M
		110	1268M
6	Top	150	1277M
		110	1278M
7	Back	150	1287M
		110	1288M
8	Front Filler	150	1297M
		110	1298M
9	Side Filler	150	1307M
		110	1308M

ITEM	DESCRIPTION	MODEL	PART#
10	Firewall	150	1317M
		110	1318M
11	Firepot S/S	150-110	1327M
12	Pyrolite Liner (11") Pyrolite Liner (14")	150-110	90911
			92414
13	3/8" x 1" Hex Bolt	150-110	2197M
14	3/8" Lock Washer	150-110	2207M
15	Filter Filler	150	1337M
		110	1338M
16	Fireport Gasket	150-110	9107M
17	Burner Tube Gasket	150-110	9117M
18	Bottom	150	1347M
		110	1348M
19	Venturi Plate	150-110	1288M
20	Plate Gasket	150-110	9108M

NOTE: Air filter required. 110 16" x 20" x 1"
150 20" x 20" x 1"

MULTI-FUEL PARTS LIST

WIRING HARNESS AND BLOWER

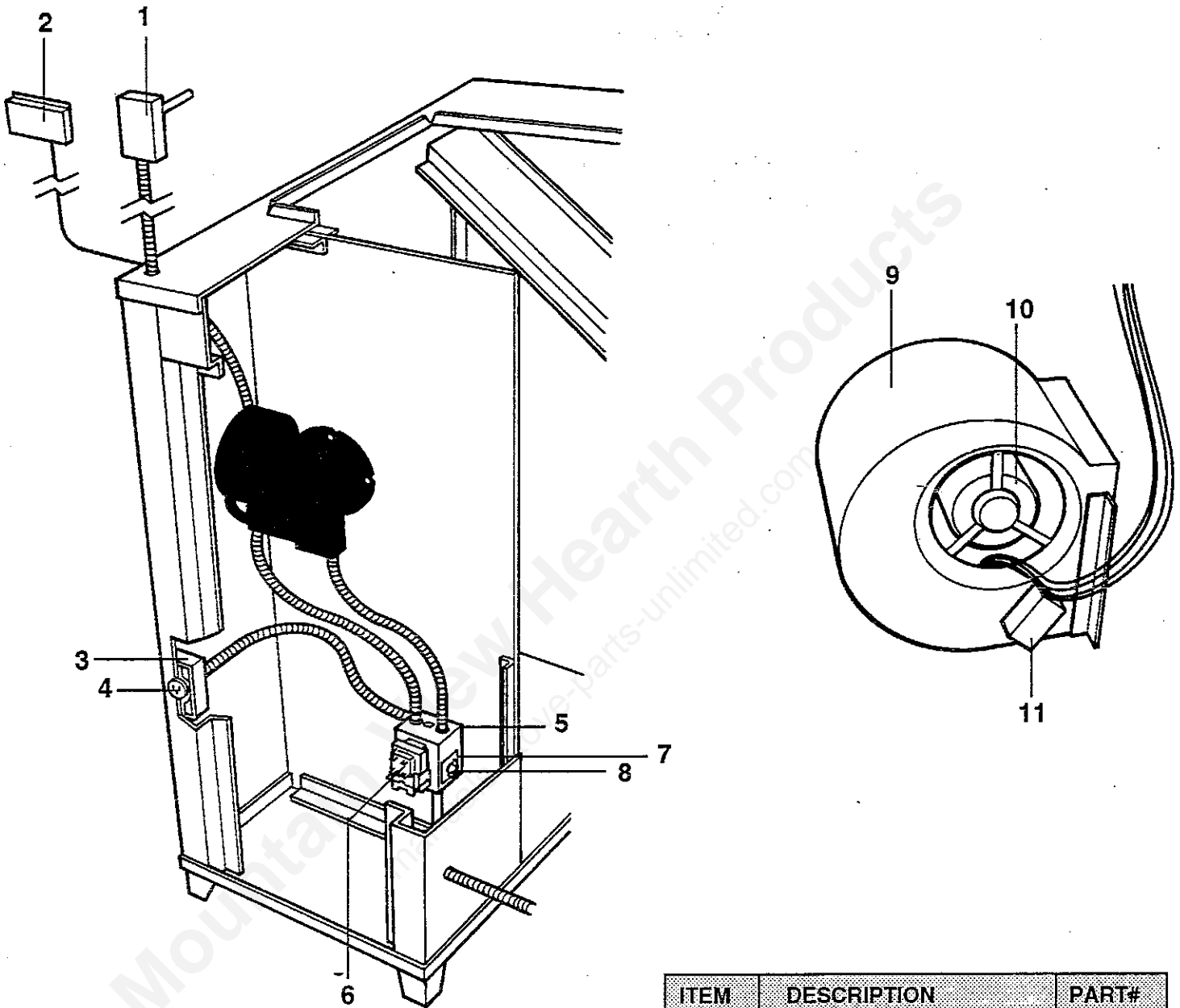

ITEM	DESCRIPTION	PART#
1	High Limit Control	4707M
2	Dual Control Thermostat	4617M
3	Racor Box	40299
4	Grounded Receptacle	4057M
5	F.A.D. Box	1507M
6	Fan Center R8325B	4647M
7	3-Speed Switch	4637M
8	Plastic Knob	9267M
9	Blower Housing 1800 (7.1)	45899
9	Blower Housing 1400 (5.6)	46799
10	3-Speed Motor	45799
11	Capacitor	45699
12	Sub-base (thermostat)	4627M

MULTI-FUEL PARTS LIST

MOTORIZED NATURAL DRAFT

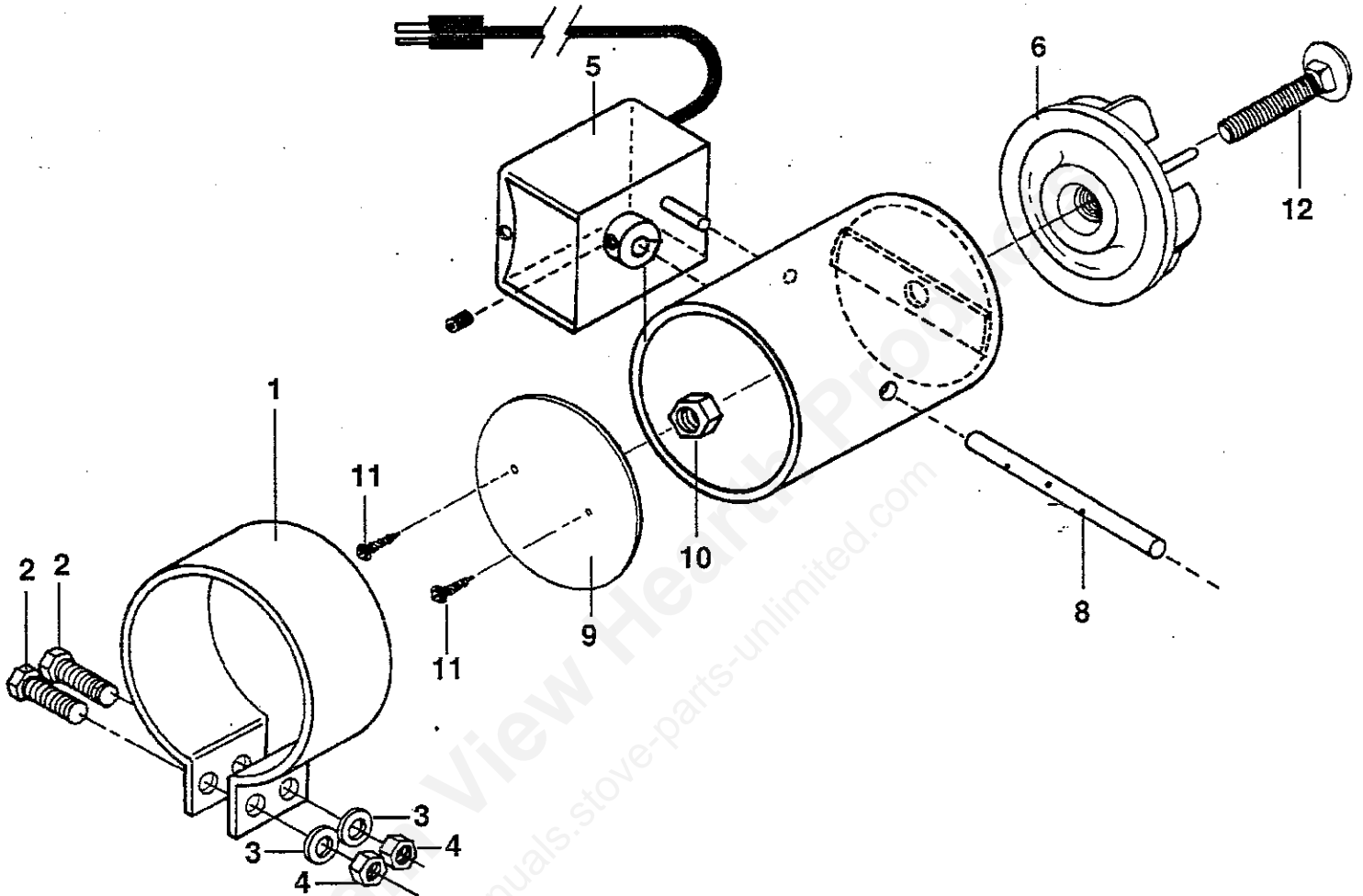

ITEM	DESCRIPTION	PART#
1	Draw Band	11257
2	1/4" x 1" Bolt	20099
3	1/4" Lock Washer	20199
4	1/4" Hex Nut	20299
5	Erie Motor - 24 Volt	4517M
6	Draft Cap	50599
7	Draft Tube (Special)	1137M
8	Flipper Tube	11457
9	Flipper	11557
10	1/2" - 13 Hex Nut	20399
11	#8 x 1/2" Tek Screw	20499
12	1/2" x 2-1/2" Carriage Bolt	20599
13	24-Volt Pigtail	4177M

PARTS LIST MODEL 150 & 110 HSG200 GAS BURNER

ITEM	PART #	DESCRIPTION
1	47420	Burner Housing 62421-001
2	47421	Air Tube 62576-015 (150-9")
	47419	Air Tube 62576-003 (110-6")
3	47422	Air Cone 62393-001
4	47423	Mounting Flange 62205
5	47424	Flange/Gasket 100428
6	47425	Blower Wheel 5-1/4" O.D. 21664
7	47426	Blower Wheel Bushing 62386-001
8	47427	Side Plate/Motor Housing 62405-001
9	47428	Motor Shaded Pole 1/12 HP, 3200 RPM, 115V/60HZ 62355-001
10	47429	Combustion Air Damper 100373
11	47430	Control Box 62518-001
13	47431	24V Transformer 60186
14	47433	Motor Relay 62406-001
15	47434	Honeywell S89F-1007 Gas Control w/30 Sec. Prepurge 62759-001
	47498	Fenwal 05-319000-251 Gas Control w/30 Sec. Prepurge 62911-001 Mounting Plate for 62911-001 Only 62912-001
16	47435	Damper Indicator 100377
17	47436	Air Proving Switch, Only 62382-002
18	47437	Air Proving Switch/Mounting Plate Slot Cover Assembly 62474-002
	47438	Thermostat 60178
19	47439	Terminal Strip
20	47440	Adjustment Arm
21	47441	Off-Cycle Damper 100372 Off-Cycle Damper Plate 100371
22	47442	Mounting Bracket Off-Cycle Damper 100378
23	47443	Junction Box 162516-00
24	47444	Ignition Transformer 62407-001
25	47445	Electrode Assembly 62391-002
26	47446	Sensor Assembly 62390-002
27	47447	Insulator Bushing 62387-001
28	47448	Chamber/Manifold HSG 9" 62575-014
29	47449	Clip, Electrode Bracket 62419-001
30	47450	Electrode Bracket 61951-001 Support Includes Items 27, 29, and Set Screws
31	47451	14" Sensor Wire - HSG 9" 62411-030
32	47452	11" Ignition 62909-002 Wire - HSG 9"

ITEM	PART #	DESCRIPTION
33	47453	Baffle Plate 162426-001
34	47454	Top Plate/ Housing Cover 62792-003
35	47455	Strain Relief Bushing/Sensor Wire 62697-001
36	47456	Strain Relief Bushing/Ignition Wire 62304
37	47457	Orifice Housing 162402-001
38	47458	Orifice Spring 62410-001
39	47459	Orifice Gasket 62401-001
40	47460	Orifice Cap 62385-001
41	47461	Gas Valve - Robertshaw 7000BDER 62374-001
	47418	Gas Valve - Honeywell VR845M 62474-001
42	47462	Orifice .277 Dia. Nat. 62438-007 Std. 150
43	47463	Orifice .199 Dia. L.P. 62438-005 Std. 110 Elbow Street - 3/4 NPT (not shown) 62866-001

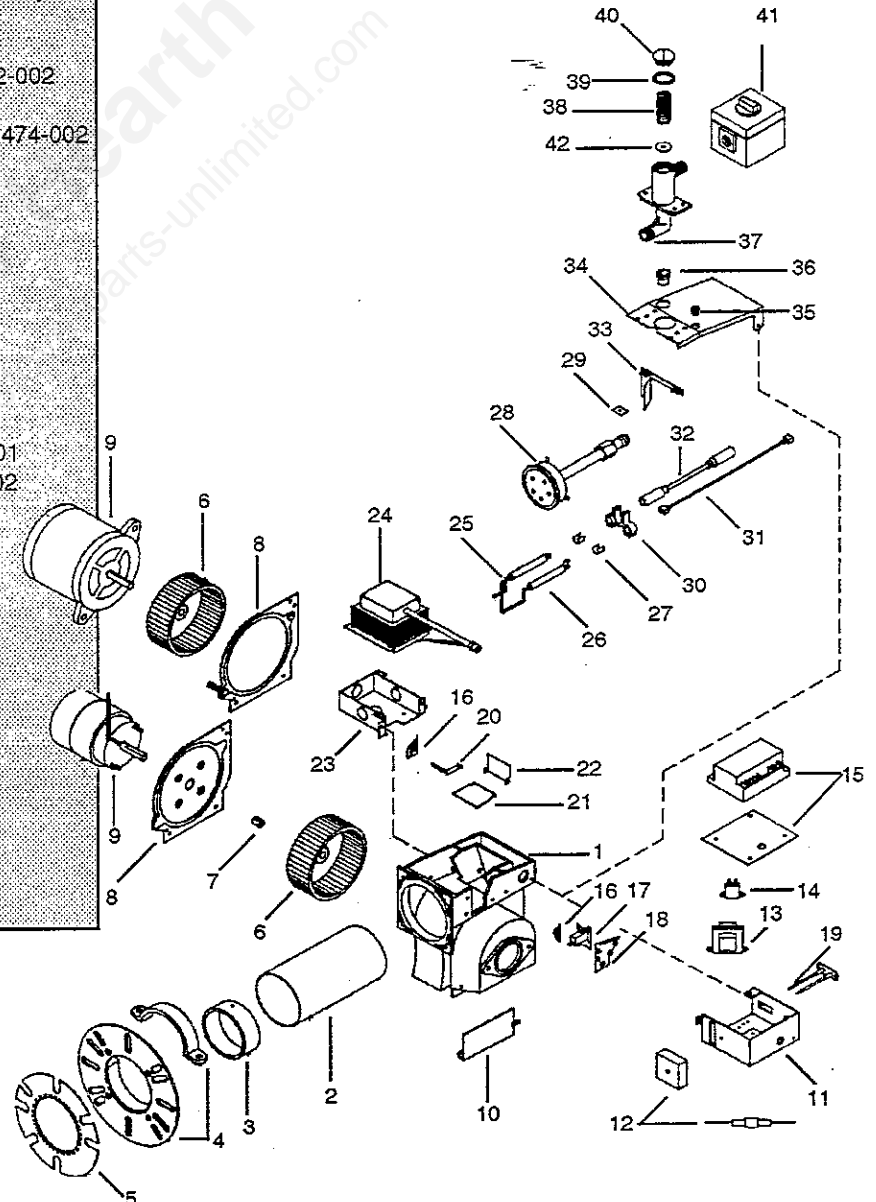

PARTS LIST HS OIL BURNER

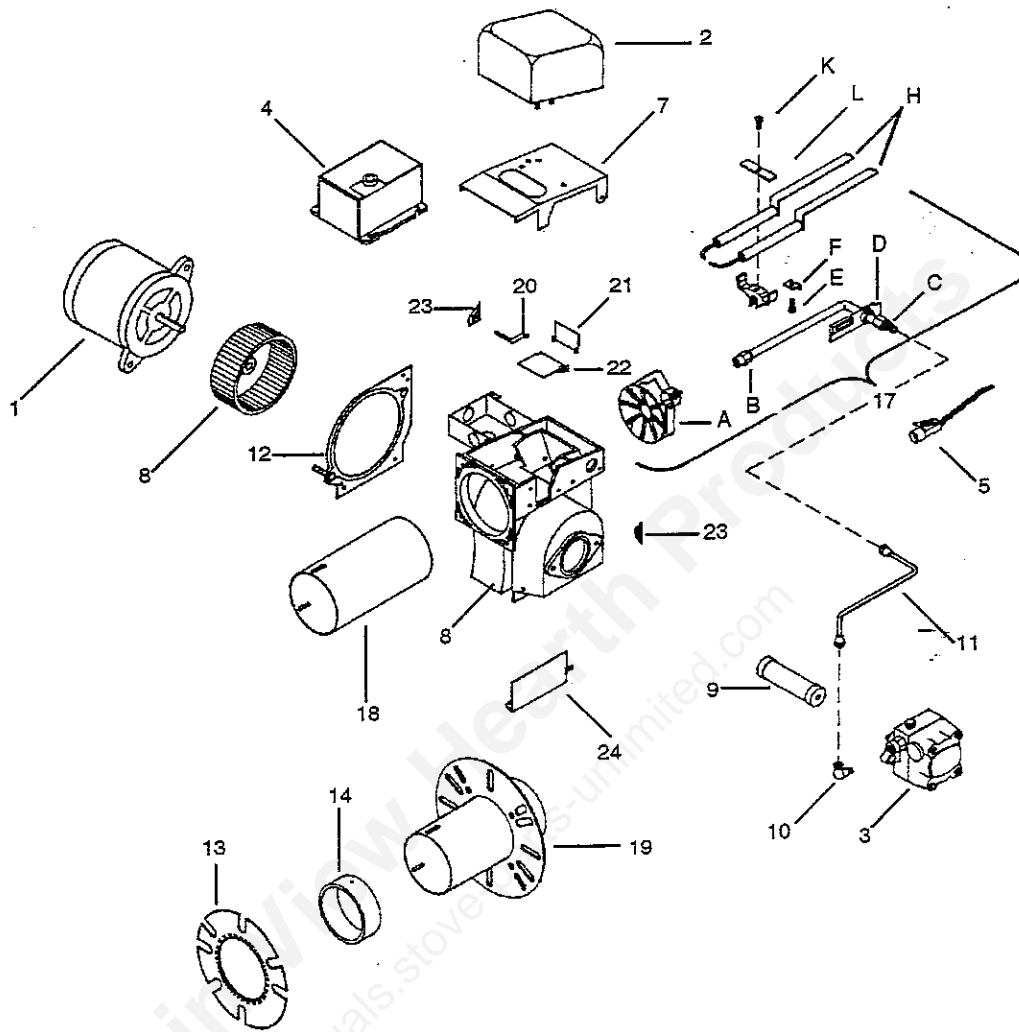

ITEM	PART #	DESCRIPTION	ITEM	PART #	DESCRIPTION
1	47464	Motor, 1/8HP, 3450 RPM, 115/V, 60HZ 20627	17D	47482	Slide Cover Plate 100518-001
2	47465	Ignition Transformer 115/V, 60HZ, Primary 10,000 Volt Secondary 21659	17E	47483	Set Screw 12693
3	47466	Suntec A2VA-7116, 1-Stage Fuel Unit 13495	17F	47484	Support Mounting Clip 100447-001
4	47467	45 Sec. Oil Burner Primary Control 13084	17G	47485	Electrode Support 100449-001
5	47468	Cad Cell 15" Lead 14285	17H	47486	Electrode Assembly L.H. 21667-025 Electrode Assembly R.H. 21666-025
6	47469	5.50 O.D. Blower Wheel 21642	17J	47487	Electrode Cross Bar 100384
7	47470	Housing Cover Plate 21680	17K	47488	Cross Bar Mounting Screw
8	47471	Burner Housing Assembly 30885		47489	100418-003
9	47472	Coupling 100386	18	47490	Air Tube 9" 21886-025
10	47473	Oil Line Elbow 13494		47499	Air Tube 4" 21886-013
11	47474	6" Oil Line Assembly 14451	19	47423	Mounting Flange 62205
12	47475	Motor Mounting Side Plate 21658	20	47492	Off-Cycle Damper Adjustment Arm 100372
13	47476	Flange Gasket 100428	21	47493	Off-Cycle Damper Mounting Bracket 100378
14	47477	Air Cone - No Holes 100420	22	47494	Off-Cycle Damper Plate 100371
17	47478	Gun Assembly Complete 31371-025	23	47495	Indicator Pointer 100377
17A	47479	10 Vane FlameLock 100393	24	47496	Inlet Air Damper 100373
17B	47480	Nozzle Adapter 12362	25	14464	.75 Nozzle-110 (not shown) Std.
17C	47481	Oil Line Gun Fitting 100382		14462	.85 Nozzle-150 (not shown) Std.



TRI-STAR LIMITED WARRANTY

The manufacturer warrants to the original owner that this furnace will perform properly when installed according to their specifications for five (5) years on a prorated basis, with the exception of electrical components. Prorated adjustments will be made on a depreciated factor of 20% per year on the distributors purchase price. Such repair or replacements shall be made as determined by TRI-STAR INDUSTRIES, INC.

The electrical components are warranted according to the electrical or plumbing manufacturer's guarantee.

This warranty is limited to repair or replacement of the parts involved. All labor and transportation charges are the responsibility of the purchaser. Any request for repair or replacement should be directed to the dealer from which the unit was purchased. TRI-STAR INDUSTRIES, INC. shall not be liable for any delay or failure of performance due to any causes beyond its control including acts of God or governments, labor disputes or inability to obtain materials or transportation. TRI-STAR INDUSTRIES, INC. time for performance shall be extended for a period equal to the duration of such delay. All claims must be accompanied by a sales invoice or equivalent information. All claims of this warranty is that the purchaser notify TRI-STAR INDUSTRIES, INC. before returning any defective parts.

This warranty does not apply to normal maintenance, any materials repaired or altered in a way which TRI-STAR INDUSTRIES, INC. reasonably determines to have adversely affected performance of liability, any materials subject to misuse, neglect or accident, electrical power interruption, or any expendable or consumable items. No repair or replacement shall extend any warranty.

This warranty is in lieu of any other warranty express or implied. INCLUDING MERCHANTABILITY OR FITNESS FOR PURPOSE, and any warranty otherwise arising out of any proposal, specification or sample. TRI-STAR INDUSTRIES, INC. neither assumes nor authorizes any person to assume for it any other liability. IN NO EVENT SHALL TRI-STAR INDUSTRIES, INC. BE LIABLE FOR DIRECT, SPECIAL OR CONSEQUENTIAL DAMAGES IN CONNECTION WITH THE PURCHASE AND SALE OF THIS EQUIPMENT OR ANY RELATED SERVICES.



OWNERSHIP RECORD

DEALER'S NAME _____

ADDRESS _____

CITY _____ STATE _____ ZIP _____

DATE OF PURCHASE _____

FURNACE MODEL NO. _____

SERIAL NO. _____

WARNOCK HERSEY SERIAL NO. _____

NOTES _____

The Tri-Stars have been safety tested by Warnock Hersey Inc. to the following standards: UL 391-1991, ANSI Z21.47A-1991, CSA B366.1-M1991, ETLM 78.1.

**Registration
Card must be
completed and
mailed within
10 days of
purchase
to validate
warranty.**

TRI-STAR INDUSTRIES, INC. WARRANTY REGISTRATION CARD

PLEASE PRINT CLEARLY

1) Name _____

Address _____ City _____

State _____ Zip _____ Phone (_____) _____

2) Dealer's Name _____

Address _____ City _____

State _____ Zip _____ Date of Purchase _____

3) Furnace Model No. _____ Serial No. _____

4) First learned of Tri-Star through: _____

5) Purchased this furnace because: _____

6) Additional Comments: _____

Mountain View Hearth Products
manuals.stove-parts-unlimited.com

From _____

PLACE
STAMP
HERE

TRI-STAR INDUSTRIES, INC.
106 West Lind Street
Mankato, Minnesota 56001