



# TRI-STAR INDUSTRIES, LTD.

---

Model TSG-2340

## GAS PEDESTAL FIREPLACE

*Installation / Operator's Manual #31564*

### FOR YOUR SAFETY

Do not store or use gasoline or other flammable vapors and liquids in the vicinity of this or any other appliance.

If you smell gas:

1. Open windows
2. Don't touch electrical switches
3. Extinguish any open flame
4. Immediately call your gas supplier

**CAUTION:**  
Read Rules for  
Safe Operation  
& Instructions  
**CAREFULLY**

### IMPORTANT:

Installation must be made in accordance with State and local ordinances which may differ from this installation manual.

# TABLE OF CONTENTS

INTRODUCTION .....	1
Important Information and Specifications .....	1
Spill Switch Installation.....	2
FIREPLACE DIMENSIONS.....	3
CLEARANCES TO COMBUSTIBLES .....	4
INSTALLATION	
TSG-2340-GF .....	4
Gas Pipe and Burn.....	5
Installation of Logs .....	5
Remote Wall Switch .....	7
Blower .....	7
OPERATION AND MAINTENANCE	
Lighting .....	7
Maintenance .....	8
Shut-down.....	8
Removal of Door Assembly and Glass.....	8
Fan Removal .....	8
Gas Pressure Requirements.....	9
OPTIONAL EQUIPMENT.....	8
MILLIVOLT TESTING .....	9-10
TROUBLESHOOTING .....	11-12
PARTS LISTS	
TSG-2340 Gas Fireplace.....	13
TSG-2340 Gas Burner and Spill Switch .....	14
TSG-2340-Gas Freestanding .....	15-16
WARRANTY .....	17

# INTRODUCTION

## WARNING

Improper installation, adjustment, alteration, service or maintenance may void warranty and cause injury or property damage. Refer to this manual.

For assistance or additional information, consult a qualified installer, service agency or the gas supplier.

Installation must conform with local codes or with the national fuel gas code ANSI Z223.1-988 or with CANI-B149 installation code.

## IMPORTANT INFORMATION

For safe installation and operation of your gas fireplace, please note the following:

1. This appliance gives off high temperature and should be located out of traffic areas and away from furniture and draperies.
2. Children and adults should be alerted to the hazards of the high surface temperatures of this appliance and should stay away to avoid burns or ignition of clothings.
3. Children should be carefully supervised when they are in the same room as your fireplace appliance.
4. Under no circumstances should this appliance be modified. Parts that have to be removed for servicing should be replaced prior to operating this appliance.
5. Installation and any repairs to this appliance should be done by a qualified service person. A professional service person should be called to inspect this appliance annually. Make it a practice to have all of your gas appliances checked annually.
6. Control compartments, burners and air passages in this appliance should be kept clean and free of dust and lint. Make sure that the gas valve and pilot light are turned off before you attempt to clean this unit.
7. The venting system (chimney) of this appliance should be inspected at least once a year and if needed, your venting system should be cleaned.
8. Keep the area around your appliance clear of combustible and liquids. This appliance should not be used as a drying rack for clothings, nor should Christmas stockings or decoration be hung in the area of it.
9. This appliance requires adequate ventilation for safe operation. Outside Air Kit is available from your local dealer if desired or required by local code.

10. Do not operate this appliance without glass in place. Replace damaged glass only with original equipment glass or equivalent. (Consult your Tri-Star dealer).
11. Under no circumstances should any solid fuels (wood, paper, cardboard, coal) be used in this appliance.

**THIS APPLIANCE IS FOR USE WITH NATURAL OR PROPANE GAS ONLY AS INDICATED ON RATING PLATE.**

**NOTE:** BTU ratings shown on the rating plate area for elevations up to 2,000 feet, for elevations up to 2,000 feet. For elevations above 2,000 feet, rating should be reduced at the rate of four (4) percent for each 1,000 feet above sea level.

GAS SPECIFICATIONS			
MODEL	FUEL	GAS CONTROL	MAXIMUM INPUT
C40NG	Natural	Remote On/Off	26,000 BTU/HR
C40PG	Propane	Remote On/Off	23,500 BTU/HR
Manifold Pressure - Natural Gas 3.5" W.C.P.			
Propane Gas 10.5" W.C.P.			
Gas Inlet - 1/2" NPT			
Supply	Minimum Pressure		Maximum Pressure
Natural Gas	4.5" W.C.P.		10.5" W.C.P.
Propane **	10.0" W.C.P.		14.0" W.C.P.

L.P. AND NATURAL ORIFICE			
0-2,000 feet	-	Natural	#41
		L.P.	#54
2,000-4,500 feet	-	Natural	#42
		L.P.	#55
4,500-6,000 feet	-	Natural	#43
		L.P.	#56

# Spill Switch Replacement - (Factory Installed)

The spill switch is a temperature sensitive safety device that automatically shuts off the gas burner if heat of approximately 250 degrees or more is detected in the area of the flue outlet. Excessive temperature is usually the result of an improper flue connection. Once the temperature has dropped the burner can be reignited, but the spill switch will not allow continued operation until the source of the problem is corrected.

1. Remove fan access panel and gasket at the rear of the fire chamber.
2. Working through the fan compartment, slide the switch end of the spill switch mounting bracket through the square opening in the outer back of the unit.

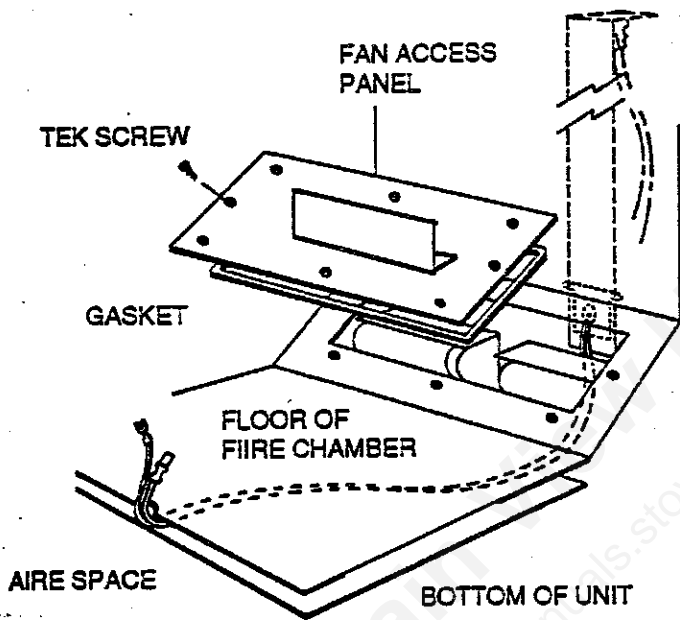

3. Slide the bracket upward until the screw hole at the bottom of the bracket lines up with the hole in the back of the unit.
4. Secure bracket from inside of fan compartment with a sheet metal screw.
5. Feed spill switch lead wires under floor of fire chamber and bring out at front of unit.
6. Replace gasket and fan access panel.

(See wiring schematic on page 6 for connection of the spill switch)

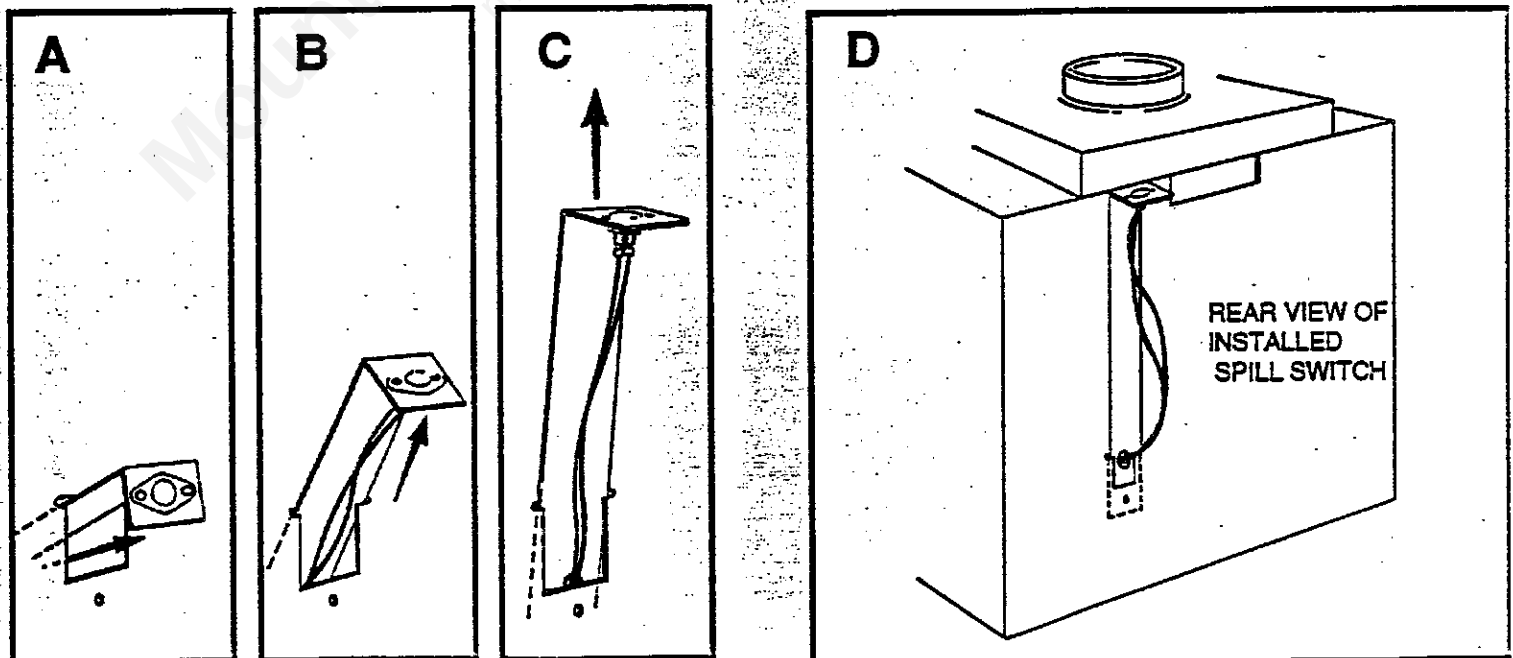
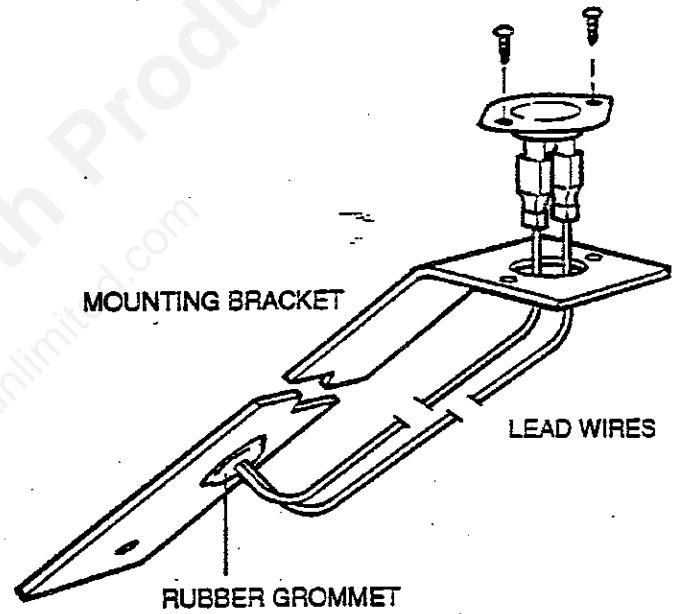

# GAS PEDESTAL FIREPLACE DIMENSIONS

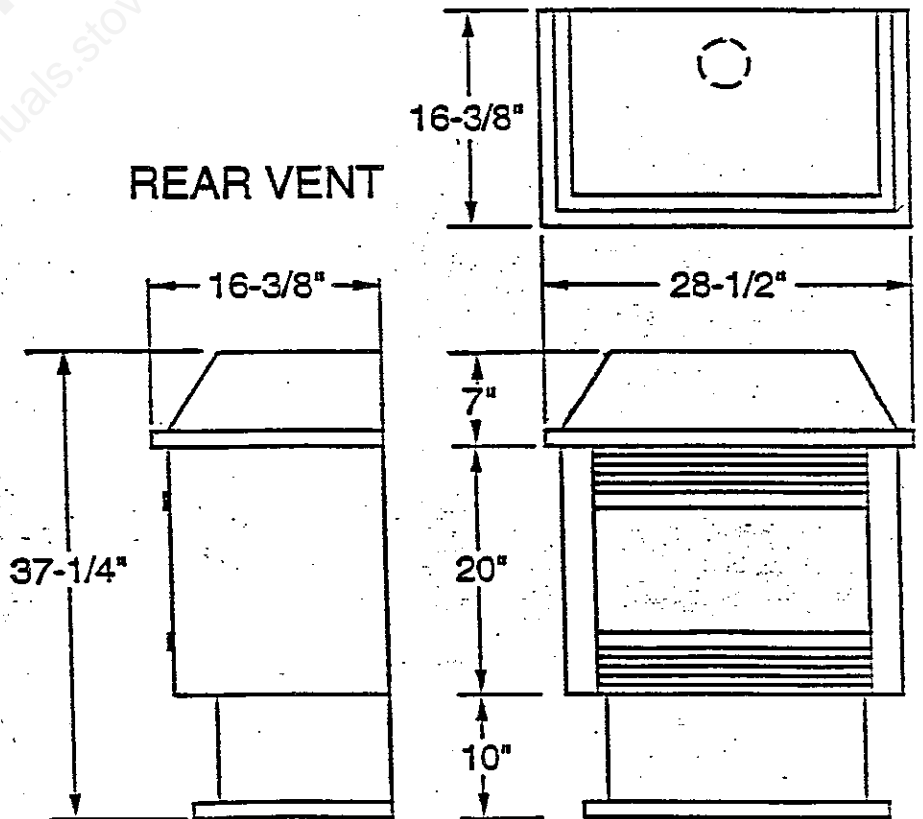
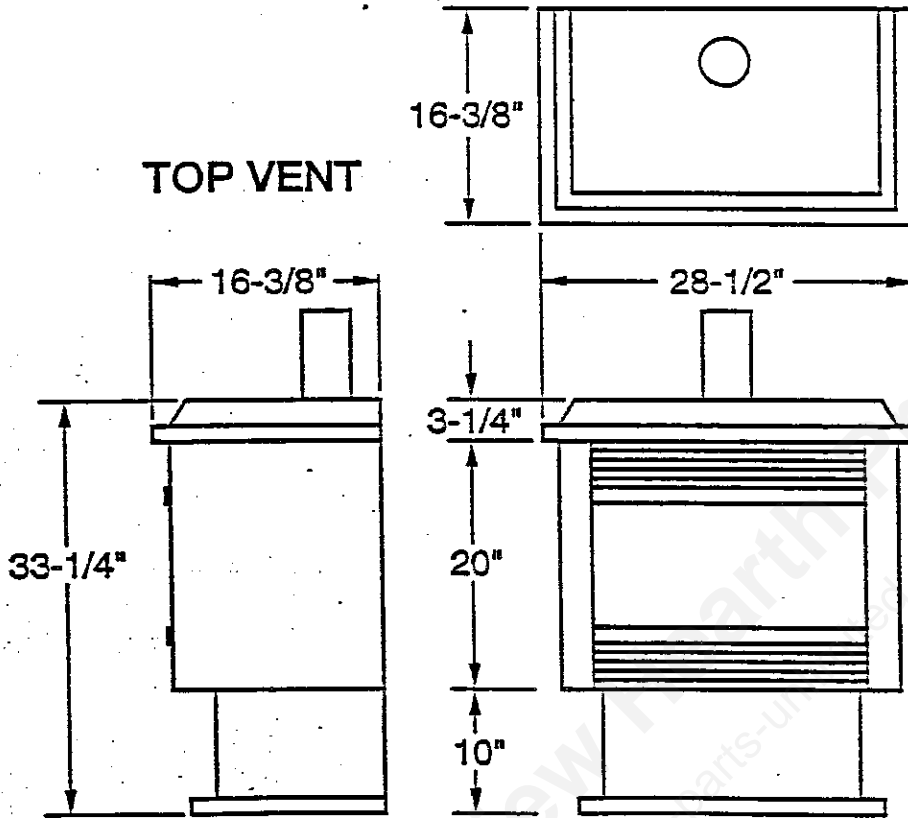

## TSG-2340 CLEARANCES TO COMBUSTIBLES

Maintain a minimum clearance of 1" on all sides of the unit and 24" above unit.

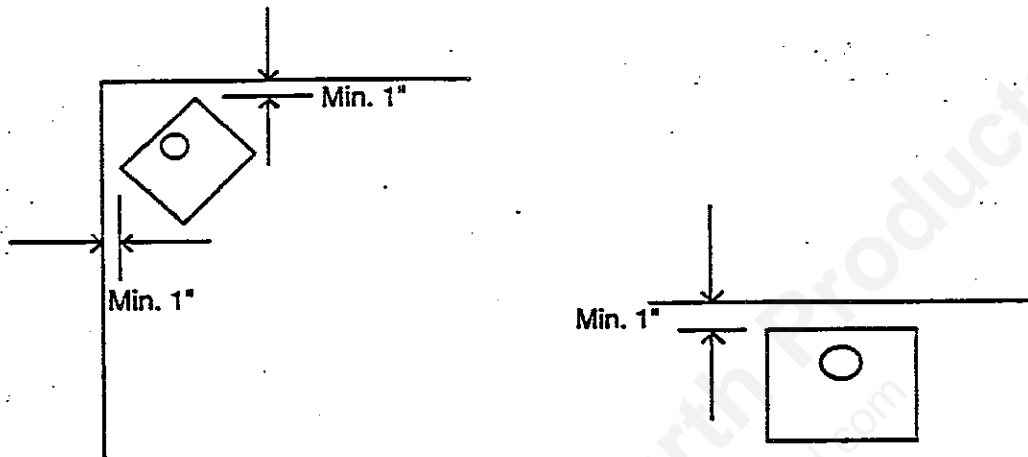

## TSG-2340-GF INSTALLATION

1. Position assembled unit in a suitable location.
2. Install an approved 4" diameter "B" - vent flue and connect to flue collar on fireplace. Consult your dealer or heating contractor for proper installation procedures.
3. Make gas connections and install logs as shown on Page 5.
4. Re-hang door assembly.
5. Plug unit into a grounded receptacle.

# TSG-2340 WIRING SCHEMATIC

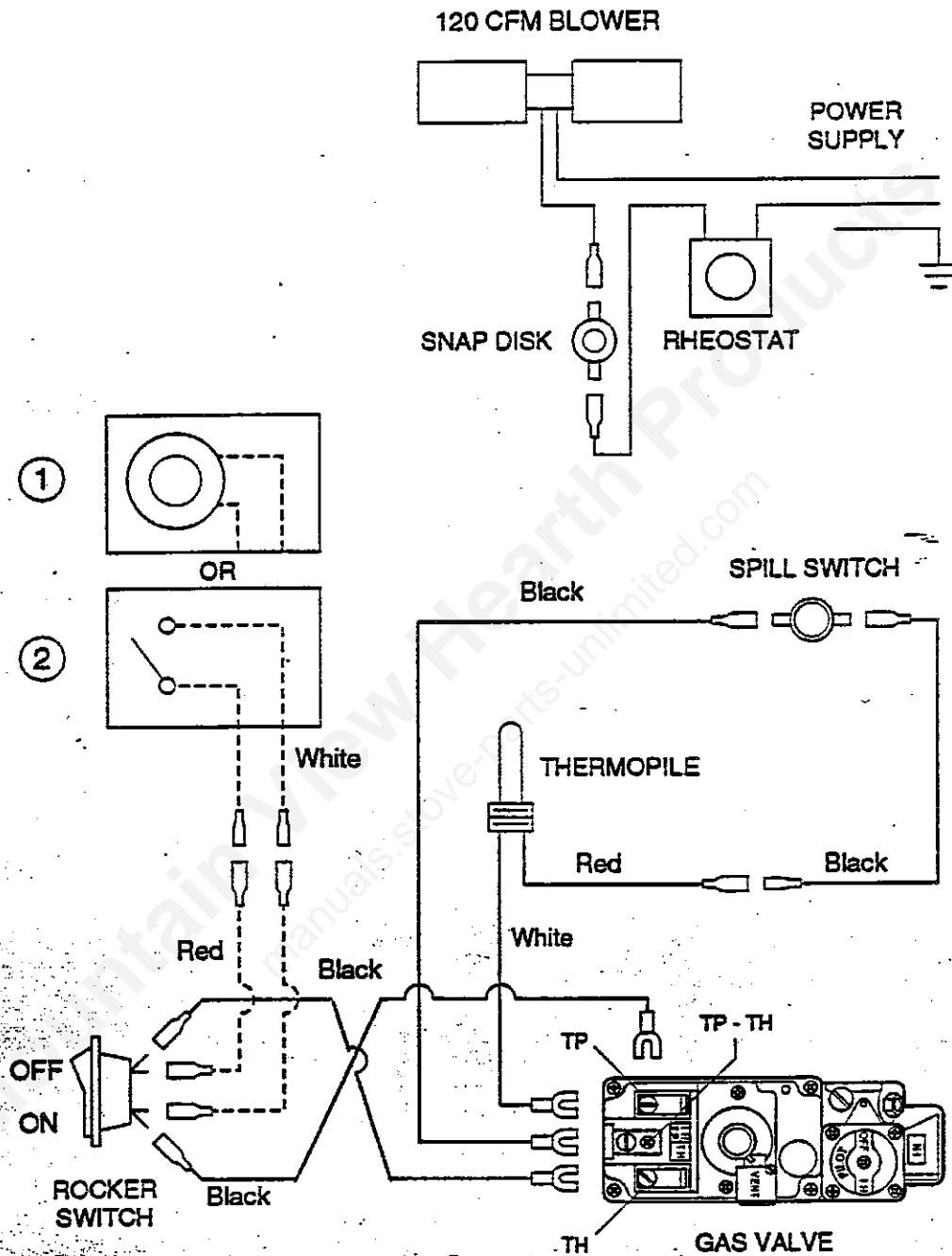

## CONTROL OPTIONS

- ① THERMOSTAT
- ② A. WALL SWITCH  
B. REMOTE

----- Indicates low voltage wiring

**NOTE:** Gas unit will not operate unless spill switch is installed.

## INSTALLATION OF REMOTE WALL SWITCH FOR AUTOMATIC GAS VALVE

1. Thread wire through gas inlet opening. Be sure not to cut wire. Run wire to a conveniently located wall receptacle box. For best long term results, switch must not be more than 10 feet from fireplace.
2. Attach wire to switch and install in receptacle box.
3. Connect wiring to gas valve.

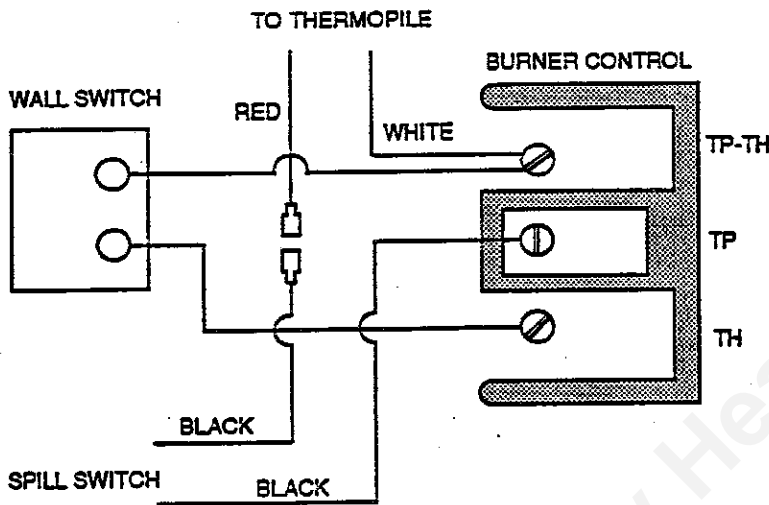

## LIGHTING PROCEDURE

**NOTE:** Remove door assembly before lighting.

1. Partially depress and turn the valve knob to the "OFF" position.
2. Wait sufficient time to allow gas which may have accumulated in the burner compartment to escape (at least 5 minutes).
3. Turn valve knob to the "PILOT" position.
4. Depress and hold valve knob while lighting pilot. Allow pilot to burn one-half minute before releasing valve knob. If pilot does not remain lighted, repeat operation allowing a longer period before releasing valve knob.
5. Turn valve knob to "ON" position.
6. If unit fails to start, repeat steps "1" through "5" or go to the troubleshooting section on page 9.

### GAS CONTROL VALVE:

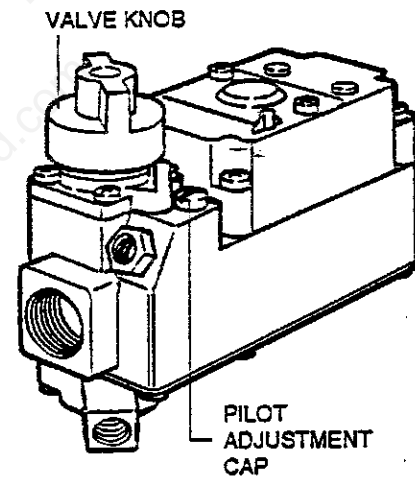

## INSTALLATION OF BLOWER (Factory Installed)

The TSG-2340 is equipped with a blower which has a speed control and a three-wire grounded cord. This appliance, when installed, must be electrically grounded in accordance with local code and national electric code, ANSI/SFPA 70.

### FAN WIRING DIAGRAM

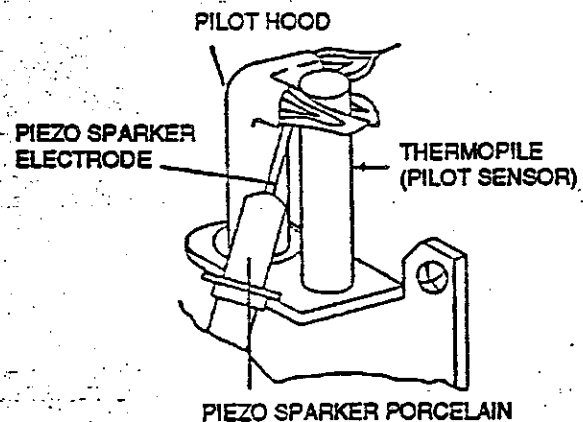
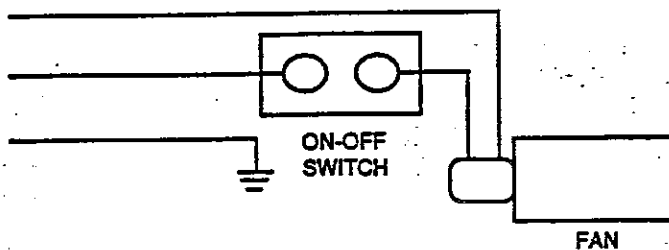

### PILOT BURNER ADJUSTMENT

1. Remove pilot adjustment cap.
2. Adjust pilot key to provide properly sized flame, the flame should cover the upper 3/8" of the tip.
3. Replace pilot adjustment cap.
4. Leak test.

## MAINTENANCE

It is important to keep burner and the burner compartment clean. This must be done periodically, at least once per season.

Steps for Cleaning Procedure:

1. Turn off pilot.
2. Remove door assembly (See instructions).
3. Remove logs.
4. Vacuum burner compartment, especially around the orifice opening.
5. Reinstall logs.
6. Replace glass.
7. Ignite pilot - see Operating Section of the manual.
8. Operate the burner and visually check to make sure the flame pattern appears similar to the pictorial illustration below.

**NOTE:** It is important to periodically perform a visual check of the pilot, the burner flame and flame impingement and to compare them with the diagram shown below. No flame should directly hit the logs.

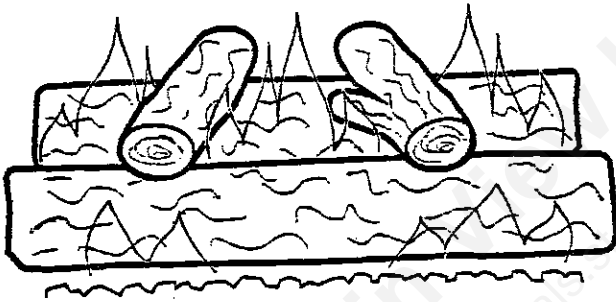

## SHUT-DOWN PROCEDURE

- a) To turn off Main Burner only, turn Valve Knob to "PILOT" position.
- b) For complete shut down, slightly depress Valve Knob, turn to "OFF" position.

The Burner Assembly has been engineered and permanently adjusted for proper flame control. **DO NOT ALTER GAS ORIFICE.**

Periodic visual checks of the Pilot Flame should be conducted to ensure that the flame is continuously present except when the Valve Knob is in the "OFF" position.

Periodically remove the logs from the grate assembly and vacuum any loose particles from the Grate and Burner area.

## REMOVAL OF DOOR ASSEMBLY AND GLASS

1. Remove two screws at bottom of door frame.
2. Remove door frame by swinging bottom out and lifting up to unhook top.
3. Lift glass straight up out of retaining channels. Note that gasket on glass faces towards front of unit. To reinstall, reverse procedure.

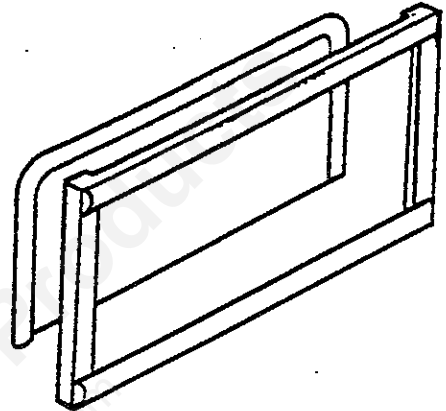

## FAN REMOVAL INSTRUCTIONS

1. Turn off gas and electricity.
2. Remove door assembly (see instructions above).
3. Remove logs and disassemble burner assembly. See page 5.
4. Remove fan cover plate (8 screws in back). Note baffle on back of fan cover plate goes up.
5. Remove two fan mounting nuts.

## OPTIONAL EQUIPMENT

### OUTSIDE AIR KIT #69065

Includes Vent Hood, 90° Elbow and Clamps.

### THERMOSTAT KIT #69142

Provides automatic temperature control. You set the temperature at your comfort level.

### HAND HELD REMOTE KIT #69070

Arm Chair convenience at the press of a button.

### WALL SWITCH KIT #69055

Allows convenience of turning unit on with a switch.

# GAS PRESSURE REQUIREMENTS

The number one cause of all operating problems with gas appliances is improper gas pressure!

Such problems as changes in flame color or configuration, gas pilot or burner outages, intermittent operation, changes in heat output, excessive burner noise, etc., are nearly always the result of changes in gas pressure or improper gas pressure at the time of the installation.

The most important item to check during the initial installation and the first thing to check when operating problems occur is gas pressure!

Gas Supplies normally enter a typical residence at 1/2 PSI (13"-15" W.C.) (3.KPA). A regulator is then placed inside the residence which drops this pressure to 7" W.C. (1.8KPS) (Nat. Gas).

This "inches to inches" regulator is of adequate capacity to service the gas appliances such as water heater, dryer, furnace, etc. If this regulator's capacity is not sufficient to add the TSG 2340-GI an additional "inches to inches: regulator must be installed specifically for the fireplace. **EXCEPTION:** some codes allow 2 PSI (1.4KPA) supplies to enter the residence, in which case "pounds to inches" regulators are used.

The following table provides information on correct gas pressure requirements. **Be sure your gas supplier or plumber carefully follows this table when installing your gas appliance.**

	DESIRED PRESSURE	MINIMUM PRESSURE	MAXIMUM PRESSURE	MANIFOLD PRESSURE*	AIR SHUTTER POSITION
<b>NATURAL GAS</b>	7.0" W.C.	4.5" W.C.	10.5" W.C.	3.5" WC	1/8" OPEN
<b>L.P. GAS</b>	11.0" W.C.	10.0" W.C.	14.0" W.C.	10.5" W.C.	FULL OPEN

\*1/8" N.P.T. Pressure tap is located on Robertshaw Control - manifold pressure must be taken with burner operating.

## MILLIVOLT SYSTEM CHECK

The millivolt system and individual components may be checked with a millivolt meter having a 0-1000 MV range. Before checking the system, be certain wall thermostat lead wire does not exceed length recommended in the Wiring Section Table, and all connections are clean and tight.

Conduct each check shown in the chart below by connecting meter test leads to terminals as indicated. All readings are closed circuit.

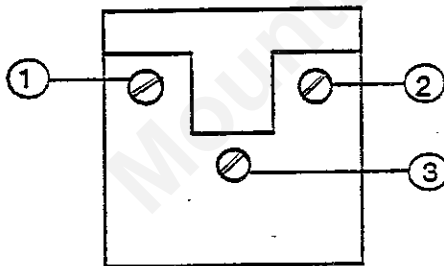

Component Check	Connect Meter Test Leads To Terminals	Wall Thermostat Contacts Should Be	Meter Reading Should Be	See Check Result Below
<b>Valve Operator System</b>	2 & 3	Closed	Greater Than 100 MV	<b>A</b>
<b>Wall Thermostat</b>	1 & 3	Closed	Less Than 80 MV	<b>C</b>
<b>Thermopile and Magnet</b>	1 & 2	Open	Greater Than 325 MV	<b>B</b>

### **A. TEST RESULTS**

If the reading is more than 100 millivolts and the automatic valve does not come on, replace the valve operator. If the closed circuit reading is less than 100 millivolts, determine the cause by proceeding with steps "B" and "C".

### **B. TEST RESULTS**

If "B" reading is less than 325 MV, clean and tighten all electrical connections and adjust pilot if necessary to increase millivolt output. If unable to adjust to at least the specified minimum, change the thermopile.

When proper thermopile output is obtained, the magnet may then be checked. With pilot in operation, allow meter reading to stabilize. Extinguish pilot burner and note meter reading at dropout point of magnet. If magnet remains locked up to a reading of 120 MV or less, the magnet is good.

### **C. TEST RESULTS**

If "C" reading is more than that specified for the system being checked, clean and tighten thermostat leads and connection, shorten lead wires if possible or use heavier gauge wire. Rapidly cycle thermostat to clean contacts, or change the thermostat.

# PRESSURE REGULATOR ADJUSTMENTS

Adjustment of the pressure regulator is not normally necessary since it is preset at the factory. However, field adjustment may be accomplished as follows:

**NOTE:** Manometer attachment may be accomplished at pressure tap plug, below control outlet, as shown in figure below.

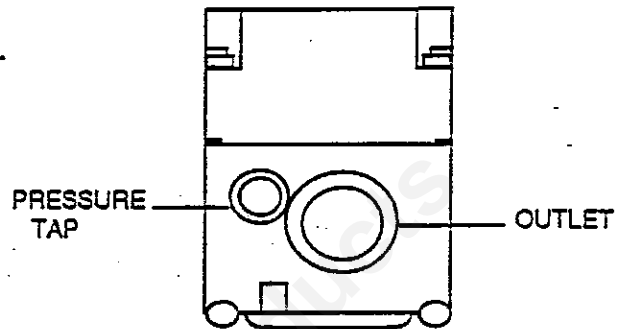

## MANUAL AND ELECTRIC MODELS

1. Manometer or gauge attachment may be accomplished at pressure tap plug.
2. Remove regulator adjustment screw cap (top of regulator).
3. With small screwdriver, rotate adjustment screw "clockwise" to increase, or "counterclockwise" to decrease pressure.
4. Replace regulator adjustment screw cap.

Tri-Star products have been safety tested by Warnock Hersey Inc. to the following standards:  
ANSI Z21.11.1b and Can 1-2.1-Vented Room Heater.  
Safety Controls - AGA Certified  
Switches and Rheostats - UL Listed

## AGA/ANSI APPROVAL

Gas appliances must be tested and certified by a nationally recognized testing and certification laboratory to ANSI (American National Standards Institute) gas appliance safety standards.

There are a number of nationally recognized testing and certification agencies around the United States and Canada. Among them are Warnock Hersey, AGA Laboratories, UL Laboratories, etc.

The Tri-Star TSG 2340-GI has been tested and certified by Warnock Hersey Inc., 8431 Murphy Drive, Middleton, Wisconsin 53562 to ANSI #Z21.111b vented room heater and CAN 1-2.1.

The Tri-Star TSG 2340-GI has met all necessary AGA/ANSI Standards and are fully certified for installation in any community. If there are any questions or if you need further substantiation either write to or call Warnock Hersey, Inc. in Middleton at (608) 836-4400, Wisconsin or call Tri-Star Industries, Inc., at (507) 345-3048.

# TROUBLESHOOTING

---

**PROBLEM: Piezo sparker won't light pilot.**

**POSSIBLE CAUSES:**

1. Misaligned electrode.
2. Incorrect wire connections.
3. Defective electrode (too cracked, dirty, or misaligned).
4. Defective push button.
5. No gas present.

**REMEDIES:**

1. Realign electrode so it produces spark into pilot hood (approximately 1/8" from pilot hood).
  2. Make sure connections are proper.
  3. Replace electrode if shorted out or if it has cracked porcelain.
  4. Replace push button.
  5. turn gas on.
- 

**PROBLEM: Pilot will not stay lit.**

**POSSIBLE CAUSES:**

1. Incorrect lighting procedure.
2. Pilot flame not making proper contact with thermopile.
3. Bad connection between thermopile and screw terminals on gas valve.
4. Wires on wrong terminals.
5. Thermopile is defective, dirty or weak.
6. Thermopile is shorting out where it passes through cabinet.
7. Gas valve will not prove pilot.
8. Spill switch wires not connected or bad switch.
9. Air on line.
10. Wire from valve to wall switch or remote switch is nicked or shorting out.
11. Switch defective or short in circuit.

**REMEDIES:**

1. Checking lighting instructions found on label in gas fireplace or in owners manual.
2. Adjust pilot up.
3. Make sure screws are snug holding thermopile. (Do not overtighten or you will strip them.)
4. White lead from thermopile must go to top screw TH TP terminal and red wire must go to spill switch wire.
5. Test with millivolt meter and replace if necessary. Thermopile should read about 325-550 millivolts.

6. Replace thermopile.

7. Replace valve.

8. Connect spill switch wires to valve - make sure spill switch is closed with meter.

---

**PROBLEM: Pilot stays on but main burner won't come on.**

**POSSIBLE CAUSES:**

1. Wired incorrectly.
2. Wall switch, on/off switch, or remote hand switch defective.
3. Not enough voltage being generated by pilot.
4. Defective control valve.

**REMEDIES:**

1. One wire to top screw (TH TP) of valve, one to bottom screw (TH). One wire to each side of switch or thermostat.
  2. Replace wall switch, on/off switch, or remote hand switch.
  3. Adjust pilot light up to create more voltage or replace thermopile.
  4. Replace control valve.
- 

**PROBLEM: Wall switch must be pushed multiple times to make flame come on.**

**POSSIBLE CAUSES:**

Defective wall switch.

**REMEDIES:**

Replace wall switch.

**NOTE:** Can use standard single pole electrical switch.

**PROBLEM: Window keeps getting sooty.**

**POSSIBLE CAUSES:**

Unit needs more primary air.

1. Blocked primary air port.
2. Unit is spilling.
3. Flame impingement on logs or elsewhere.
4. Logs too close to or touching glass.
5. Valve and burner over-fired.

**REMEDIES:**

1. Check between the elbow and orifice where it enters the side of the burner. Over a period of time dust, lint, pet hair, etc. can plug primary air hole. Clean out.
2. Check for blocked flue or downdraft situation.
3. Reposition logs or adjust flame.
4. Move logs to allow at least 3/8" clearance from logs to glass.
5. Check the amount of flow with monometer, and adjust regulator if necessary.

---

**PROBLEM: Dirty window. (White on window.)**

**POSSIBLE CAUSES:**

Initial burn off of paint and sealants used to produce unit.

**REMEDIES:**

1. Clean window using AJAX or COMET, and paper towel.
2. Dissolve powder AJAX or powder COMET in water on window. Clean in small circular motions. Rinse thoroughly and reinstall in unit. **DO NOT USE ANY LIQUID CLEANERS** on window. It will burn black on window when reinstalled.

**Note:** Windows are made of neo (pyro) ceramic, NOT glass. Because of this, they will handle temperatures in excess of 1,200° F constant temperature. The window only reaches between 500-600° F. Because of this it is almost impossible to bake something into the window. Most things will, with a little effort, come off if you follow these directions.

---

**PROBLEM: Circulating fan speed does not vary.**

**POSSIBLE CAUSES:**

Variable speed rheostat defective.

**REMEDIES:**

Replace rheostat.

**Note:** Only replace rheostat with a rheostat supplied by Tri-Star Industries. Light dimmer switches or incorrect rheostats will burn out the fan motor. This will void the warranty of the fan.

---

**PROBLEM: Fan makes humming sound, but won't come on.**

**POSSIBLE CAUSES:**

1. Rheostat needs adjustment.
2. Fan impellers dirty.
3. Fan defective.

**REMEDIES:**

1. Adjust variable speed control.
2. Clean fan.
3. Replace fan.

**Note:** Make sure the fan plug-in cord is not nicked by decorative trim kits. This could cause the fan to short out and also damage the gas valve.

---

**PROBLEM: Fireplace not venting**

**POSSIBLE CAUSES:**

1. Chimney blocked.
2. Air problems in house, negative pressure, etc.
3. Improper chimney installation.

**REMEDIES:**

1. Remove blockage.
2. Air used must be replaced. Guidelines can be found in your local gas codes under "Combustion Air Requirements". Install Tri-Star outside air kit.
3. Check all chimney connections for proper fit.

## TSG-2340 GAS FIREPLACE PARTS LIST

All repair parts will be available from your local dealer. When ordering, always give the following information: (A) part number, (B) part description and (C) model number.

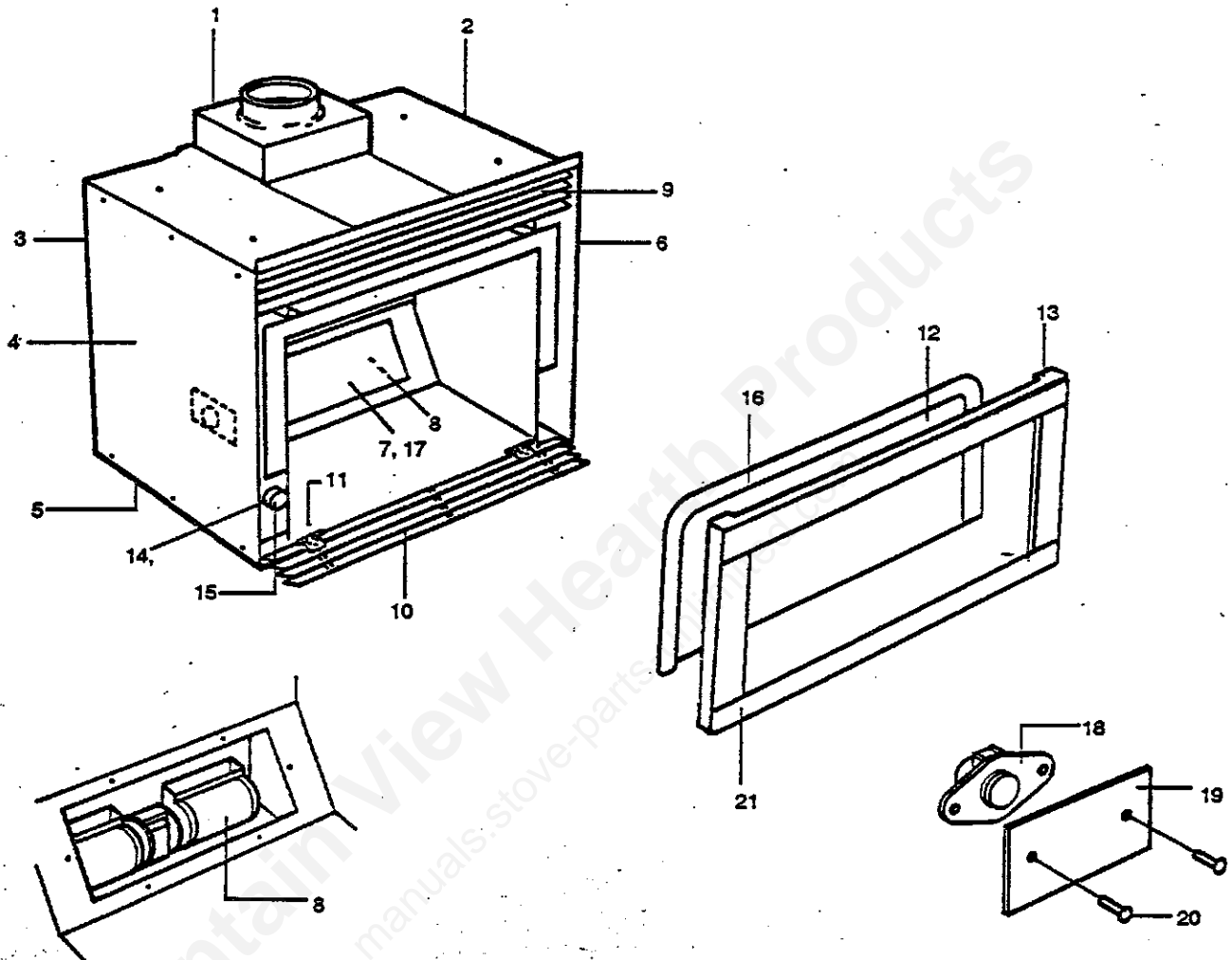

ITEM	QTY	PART #	DESCRIPTION
1	1	18501	Draft Hoop
2	1	18502	Top
3	1	18503	Outer Back
4	1	18504	Left Side
5	1	18506	Bottom
6	1	18507	Right Side
7	1	18508	Fan Cover
8	1	46750J	Blower Assembly
9	1	95965	Top Grill
10	1	95970	Bottom Grill

ITEM	QTY	PART #	DESCRIPTION
11	2	18511	Hinge
12	1	93945	Glass and Seat Assembly
13	1	18510	Glass Holder
14	1	42375	Fan Speed Control
15	1	42380	Speed Control Knob
16	1	99460	Glass Rope
17	1	97800	Fan Gasket
18	1	45575	Snap Disc
19	1	18513	Cover Plate
20	2	20500	Screw
21	2	95914	Brass Trim

# TSG-2340 PARTS LIST

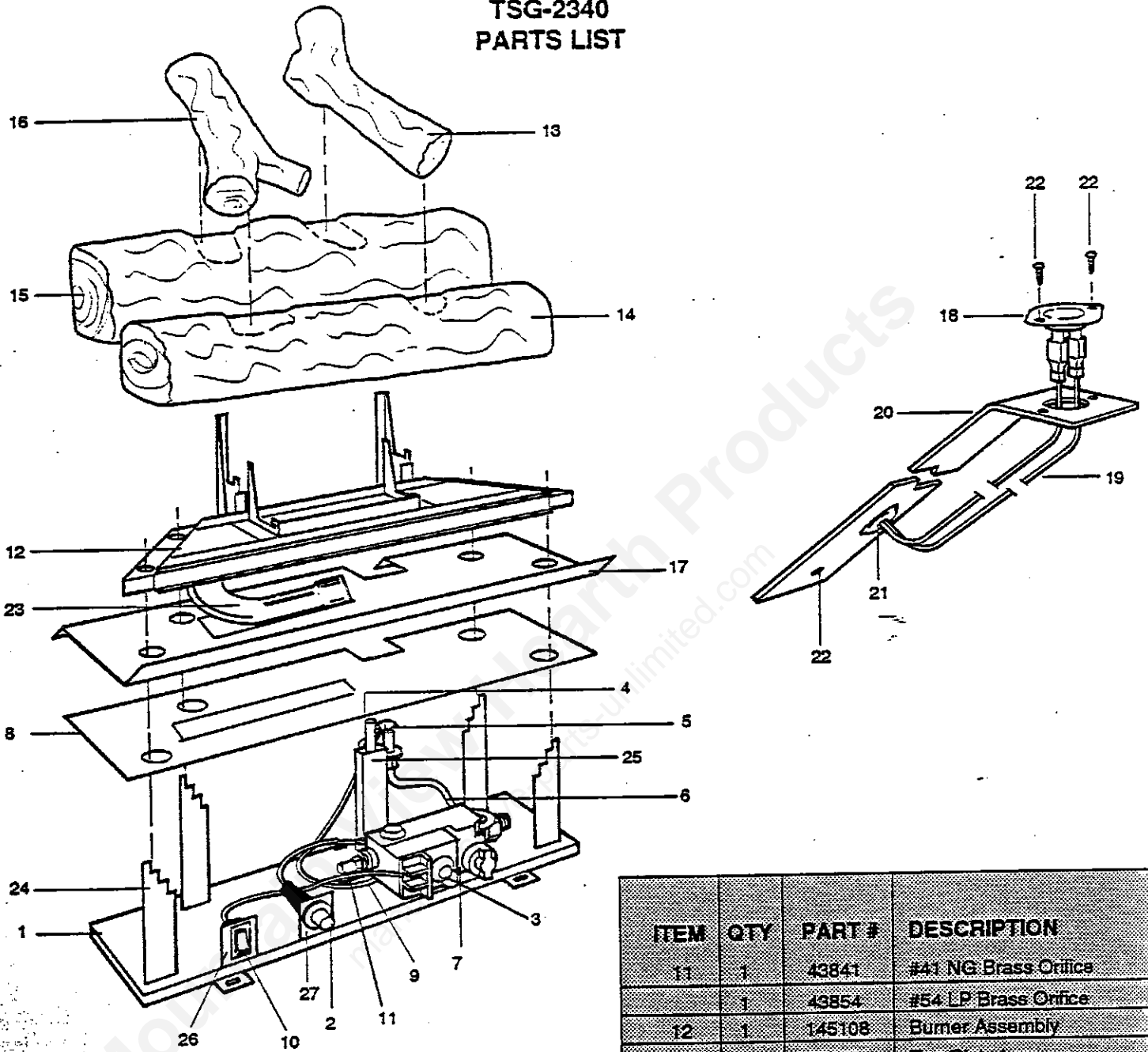

ITEM	QTY	PART #	DESCRIPTION
1	1	14566	Burner Base
2	1	43810	Piezo Ignitor
3	1	43829	NG Valve Kit
4	1	43815	Thermopile
5	1	43805	Pilot Assembly
	1	43803	NG Pilot Orifice #18
	1	43804	LP Pilot Orifice #1
6	1	95990	Pilot Supply Line
7	1	43800	Gas Valve Only
8	1	14532	Lower Heat Shield
9	1	43808	3/8" to 1/2" Bushing
10	1	42373	On/Off Rocker Switch

ITEM	QTY	PART #	DESCRIPTION
11	1	43841	#41 NG Brass Orifice
	1	43854	#54 LP Brass Orifice
12	1	145108	Burner Assembly
13	1	93167	Top Right Log
14	1	94164	Front Log
15	1	93166	Rear Log
16	1	94165	Top Left Log
17	1	14542	Upper Heat Shield
18	1	45580	250 Deg Spill Switch
19	2	43399	150 Deg Blk Stripe Wire
20	1	14567	Spill Switch Bracket
21	1	40965	3/8" Rubber Grommet
22	3	20499	#8 Tek Screws
23	1	43895	Venturi
24	4	14570	Burner Support
25	1	14575	Pilot Assembly Bracket
26	1	14567	Switch Bracket
27	1	14569	Piezo Bracket

# 40G TOP VENT FREESTANDING PARTS LIST

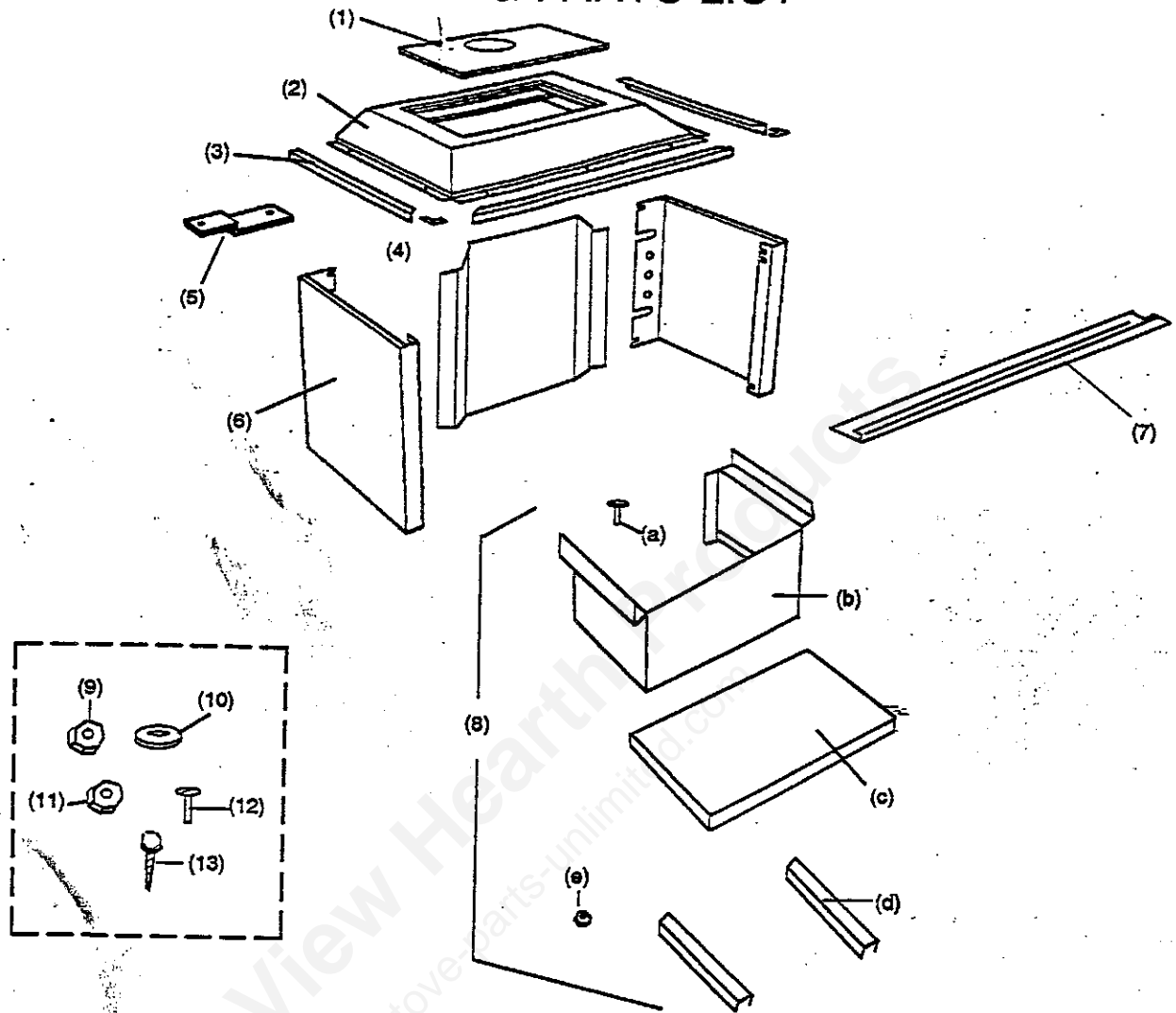

ITEM	QTY.	PART #	DESCRIPTION
1	1	14523BL	Top Vent Screen-Black
1	1	14523AL	Top Vent Screen-Almond
2	1	145103BL	Top Vent Top-Black
2	1	145103AL	Top Vent Top-Almond
3	3 pcs	95980	Freestanding Gold Trim Kit w/Hardware
4	4	14525	Top Vent Supports
5	1	14527BL	Rear Shield-Black
5	1	14527AL	Rear Shield-Almond
6	2	14524BL	Sides-Black (interchangeable)
6	2	14524AL	Sides-Almond (interchangeable)
7	1	96065	Brass Trim
8	1	145111BL	Pedestal Assembly-Black
8	1	145111AL	Pedestal Assembly-Almond
a	6	27457	10-24 Pan Head Screw
b	1	13502	Pedestal Wrapper
c	1	13504	Pedestal Base
d	2	14534	Support Channel
e	6	20799	10-24 Hex Nut
9	4	23265	10-24 Hex Nut Black
10	4	23266	3/16" Flat Washer-Black
11	4	20799	10-24 Hex Nut
12	4	23255	3/8" Sq. Head Screw
13	4	20499	#8 x 1/2" Tek Screw

# 40G REAR VENT FREESTANDING PARTS LIST

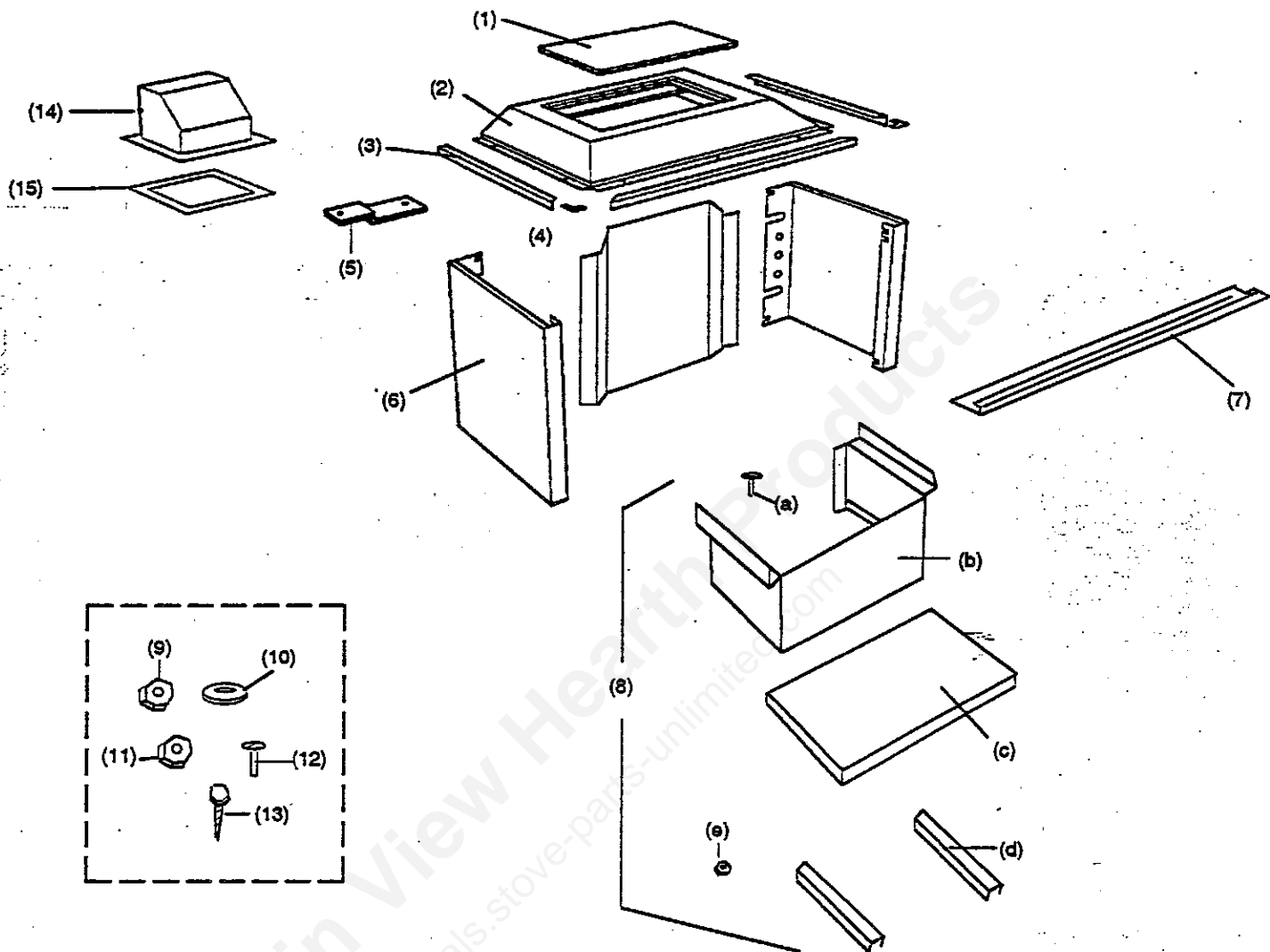

ITEM	QTY.	PART #	DESCRIPTION
1	1	14580BL	Rear Vent Screen-Black
1	1	14580AL	Rear Vent Screen-Almond
2	1	145112BL	Rear Vent Top-Black
2	1	145112AL	Rear Vent Top-Almond
3	3 pc's	95980	Freestanding Gold Trim Kit w/Hardware
4	4	14525	Rear Vent Supports
5	1	14527BL	Rear Shield-Black
5	1	14527AL	Rear Shield-Almond
6	2	14524BL	Sides-Black (interchangeable)
6	2	14524AL	Sides-Almond (interchangeable)
7	1	96065	Brass Trim
8	1	145111BL	Pedestal Assembly-Black
8	1	145111AL	Pedestal Assembly-Almond
a	6	27457	10-24 Pan Head Screw
b	1	13502	Pedestal Wrapper
c	1	13504	Pedestal Base
d	2	14534	Support Channel
e	6	20799	10-24 Hex Nut
9	4	23265	10-24 Hex Nut Black
10	4	23266	3/16" Flat Washer Black
11	4	20799	10-24 Hex Nut
12	4	23255	3/8" Sq. Head Screw
13	4	20499	#8 x 1/2" Tek Screw
14	1	14513	Flue
15	1	98295	Gasket



## TRI-STAR GAS APPLIANCE LIMITED WARRANTY

Under the conditions of this warranty, the manufacturer of the Tri-Star gas appliance warrants that the appliance is free from defects in material and workmanship for normal home use. The obligation under this warranty shall be limited to repair and/or replacement of any part or parts of the appliance which prove defective under normal home use and service with five (5) years from the date of sale of the appliance to the original purchaser and which shall be found defective by manufacturer or its authorized agent. This warranty is expressly in lieu of all other warranties expressed or implied, including warranties by statute, operation of law, or otherwise.

Manufacturer assumes no obligations or liabilities except as stated in this limited warranty which is provided for the purpose of stating the total obligations and liabilities under which manufacturer sells the appliance and to provide or original purchaser with an express, extended limited warranty. No person is authorized to bind manufacturer to any obligation or liability and this warranty expresses legal obligations of the manufacturer to the original purchaser. No obligation is assumed with respect to any other party. Manufacturer assumes no liability or obligation for any unit or accessory altered by purchaser.

This warranty does not apply to the appliance or any part thereof which has been subject to accident, negligence, alterations, abuse or misuse even if used only for home applications. The manufacturer, Tri-Star Industries, Inc., makes no warranty whatsoever in respect to accessories or parts not manufactured by Tri-Star, and which bear the name of the actual manufacturer. As to such items, the limited warranty of the accessory or part, to the extent allowed, is transferred from Tri-Star, to the original purchaser. Paint finish, trim and glass are expressly excluded from this warranty.

The original purchaser, as used in this warranty, shall be that person to whom the appliance is originally sold for home use.

This warranty shall be effective only if the original purchaser of the appliance is registered with Tri-Star Industries, by sending this warranty for to Tri-Star within thirty (30) days of the date of purchase or the date upon which the original purchaser takes possession of the appliance, whichever comes first. Such registration or failure to register shall not be deemed to create any obligation or liability by the manufacturer and this warranty with its conditions and limitation shall be the only procedure for obtaining any rights against the manufacturer and expresses the sole obligations and responsibilities of the manufacturer which are offered to the original purchaser and accepted upon purchase of the appliance.

Any cause of action by the original purchaser against the manufacturer under this warranty can be only at the situs of Tri-Star Industries, Inc. and the laws of the State of Minnesota shall be applicable to this warranty.



## OWNERSHIP RECORD

DEALER'S NAME \_\_\_\_\_

ADDRESS \_\_\_\_\_

CITY \_\_\_\_\_ STATE \_\_\_\_\_ ZIP \_\_\_\_\_

DATE OF PURCHASE \_\_\_\_\_

FIREPLACE MODEL NO. \_\_\_\_\_

SERIAL NO. \_\_\_\_\_

WARNOCK HERSEY/SERIAL NO. \_\_\_\_\_

NOTES \_\_\_\_\_

Tri-Star products have been safety tested by Warnock Hersey Inc.  
to the following standards: ANSI z21.11.1b and CAN 1-2.1 - Vented Room Heater.

**Registration  
Card must be  
completed and  
mailed within  
10 days of  
purchase  
to validate  
warranty.**

### TRI-STAR INDUSTRIES, INC. WARRANTY REGISTRATION CARD

PLEASE PRINT CLEARLY

1) Name \_\_\_\_\_

Address \_\_\_\_\_ City \_\_\_\_\_

State \_\_\_\_\_ Zip \_\_\_\_\_ Phone (\_\_\_\_) \_\_\_\_\_

2) Dealer's Name \_\_\_\_\_

Address \_\_\_\_\_ City \_\_\_\_\_

State \_\_\_\_\_ Zip \_\_\_\_\_ Date of Purchase \_\_\_\_\_

3) Fireplace Model No. \_\_\_\_\_ Serial No. \_\_\_\_\_

4) First learned of Tri-Star through: \_\_\_\_\_

5) Purchased this furnace because: \_\_\_\_\_

6) Additional Comments: \_\_\_\_\_