



*Keeping
America Warm Since
1869*

American Harvest



CORN & PELLET MULTIFUEL STOVE 6039, 6039I, 6039T OWNER'S MANUAL

Installation - Operation - Maintenance Instructions - Repair Parts

READ THIS ENTIRE MANUAL, THOROUGHLY, BEFORE ATTEMPTING TO INSTALL AND/OR BURN YOUR NEW AMERICAN HARVEST CORN AND PELLET MULTI-FUEL STOVE. FAILURE TO FOLLOW THESE INSTRUCTIONS MAY RESULT IN PROPERTY DAMAGE, BODILY INJURIES OR EVEN DEATH.

Safety Notice: If this stove is not properly installed, a **house fire may result**. For your safety, follow the installation directions. Contact local building or fire officials about restrictions and installation requirements peculiar to your area. **Do Not Plug** this appliance into an electrical outlet before reading and understanding all operations and **always unplug** the unit before attempting any work or maintenance. Do not connect this stove to any chimney flue already serving another appliance. Carefully observe and maintain all **clearances to combustibles**.

A note about fuel: Use only **dried shelled corn** with a moisture content of 14% or less (**11 to 12% provides the best results**); any pellet fuel used should have an ash content of 1% or less. If not, efficiency will suffer, and your warranty may be voided.

Your American Harvest Corn/Pellet Stove operates on a negative pressure. Therefore, **all venting connections (elbows, T-pipe) must be sealed and airtight**.

Use Hi-Temp silicone at each joint or connection.

SAVE THESE INSTRUCTIONS

UNITED STATES STOVE COMPANY GRANTS NO WARRANTY, IMPLIED OR STATED, FOR THE INSTALLATION OR MAINTENANCE OF THE STOVE AND ASSUMES NO RESPONSIBILITY FOR ANY CONSEQUENTIAL DAMAGE(S).

UNITED STATES STOVE COMPANY - 227 INDUSTRIAL PARK ROAD-SOUTH PITTSBURG, TN. 37380
TECHNICAL ASSISTANCE (423) 837-2100 - (423) 837-2109 FAX

851621E

CONGRATULATIONS!

You've purchased one of America's Finest Multifuel Burning Stoves. By heating with fuels such as corn and pellets, you're helping CONSERVE AMERICA'S ENERGY!

NOTE: YOUR UNIT MUST BE INSTALLED BY A QUALIFIED INSTALLER, such as an NFI Certified Specialist

We strongly suggest installing smoke detectors in your home if not already installed.
Initial burn off may cause slight smoke and odor the first few hours of operation.
Perform initial burn outside if possible

SPECIFICATIONS

United States Stove Company (manufacturer of the **American Harvest Multifuel Pellet Stove**) reserves the right to alter products, specifications and price without notice.

Safety Tested & Listed to ASTM- E 1509, (UM) 84-HUD, by OMNI Test Laboratories, Inc., Beaverton, Oregon USA

Heat Input, Maximum	52,200 BTU/HR	
Heat Output, Maximum ☆	48,280 BTU/HR	
Heating Capacity	1,200 Sq. Ft ★	
Fuel Storage Capacity	60 Lbs.	
Width	29 in./737mm	
Height	6039/6039T	6039I
	31 in./787mm	24 in./610mm
Depth	28 in./711mm	

☆ BTU output will vary, depending on the brand, type and quality of fuel and the moisture content. Consult your dealer for best results.

★ Based on post 1982 home construction, requiring 35 BTU/Hr per Sq. Ft.

Remember, this stove should not be used as the only source of heat in the house. Power outages and neglect of periodic maintenance will result in a total loss of heat.

ASSEMBLY

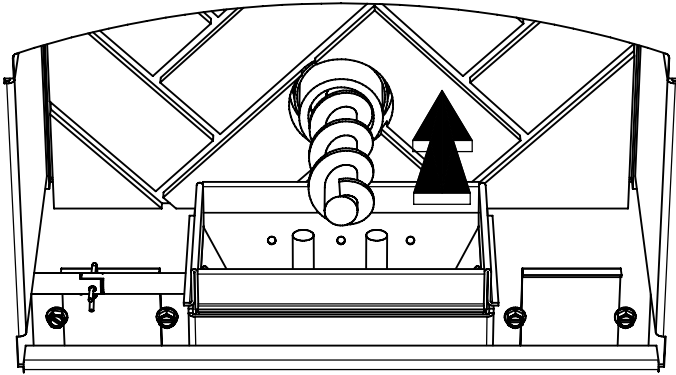

1. The Auger is packed in the hopper or ash pan and must be installed properly as illustrated below.

2. Insert the Auger into the auger tube. Rotate the auger until it fits into the coupling that is already installed on the auger motor drive. Seat the auger firmly. The Auger cannot be turned by hand once installed properly.

6039T ASSEMBLY

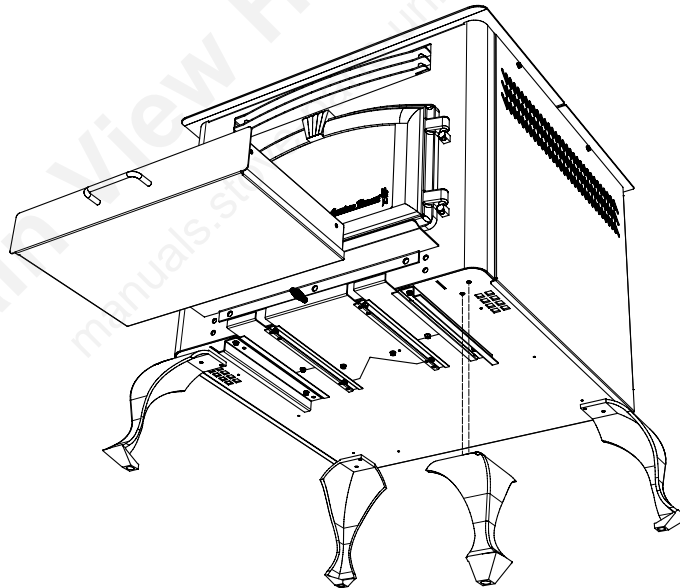

Assembly

1. Unpack unit and make sure all components are included; (4) Legs, and all hardware for installation.
2. Fold the corner padding from the carton and lay it on the floor behind the unit. This is used to hold the heater up off the floor to install the legs. Gently tilt the heater on its back, door opening up.
3. Assemble the legs as shown using the eight (8) bolts supplied.
4. After all bolts and screws have been tightened properly, carefully set the heater back up on the legs.

6039I ASSEMBLY

DISCONNECT THE POWER CORD BEFORE SERVICING THIS STOVE

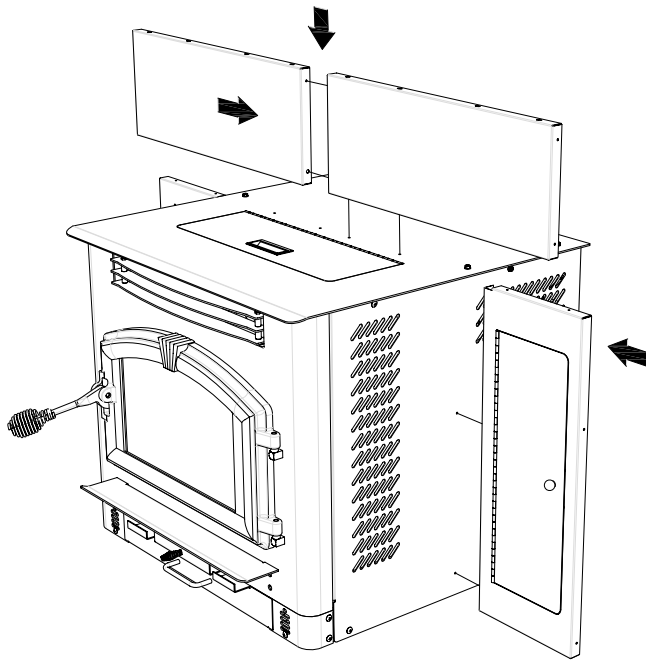

For the following assemblies, we suggest locating the unit near it's desired location. Depending on installation, you may want to connect the exhaust venting before installing the facade parts.

Assembly - Facade (Surround)

Remove contents from packaging and make sure you have all components:

- (2) Top Facade
- (1) Left Side Facade
- (1) Right Side Facade
- (4 pieces) Facade Trim Kit
- (1) Feed Door Spring Handle
- (1) Damper Spring Handle
- (1) Ash Pan "U" shaped Handle
- (1) Access Door Knob
- (1) PCB Cover
- (1) Panel Cover
- (1) Auger (in ash pan)
- (1) Power Cord
- Mounting Hardware

Start by mounting either the left or right side facade pieces to the unit using four(4) of the supplied #10 x 1/2 screws. Then put the two(2) top facade pieces together with two(2) of the #10 x 1/2 screws provided. Attach the top facade assembly to the unit with eight(8) of the same screws.

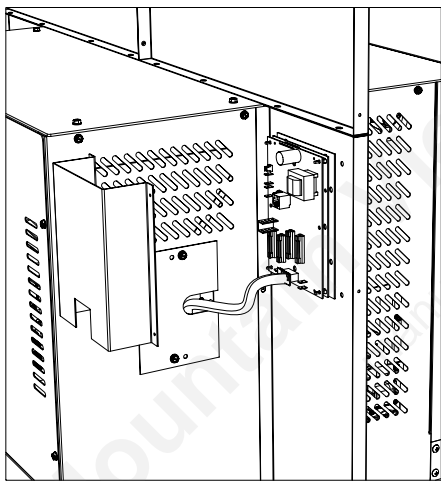

Control Board (PCB) Re-location

Remove the left side front panel from the unit. While holding the PCB with one hand, remove the two(2) hex head screws holding the board in place. It is not necessary to unplug the PCB cable. Route the board and cable through the opening and mount it to the Left Facade using two of the #10 x 1/2 phillips head screws provided. Then attach the PCB cover to the back of the facade covering the board. Next, use the two hex head screws removed earlier and mount the cover panel over the opening where the PCB was located. See illustration to the left.

Facade Trim

Remove trim from shipping tube. There should be one(1) left side, one(1) right side, two(2) top pieces, and mounting hardware. Using one blank corner key and one corner key with set screws, assemble the left trim and one of the top pieces together. As illustrated, place the blank key behind the key with the set screws. Adjust corners and tighten set screws. Repeat this for the right side

Before removing tape, place trim assembly against facade to get an idea of how it is to be mounted. Remove the strip from the adhesive and carefully secure the trim in place by firmly pressing it to the facade.

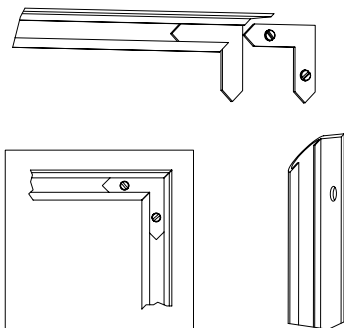

COMPONENT LOCATION

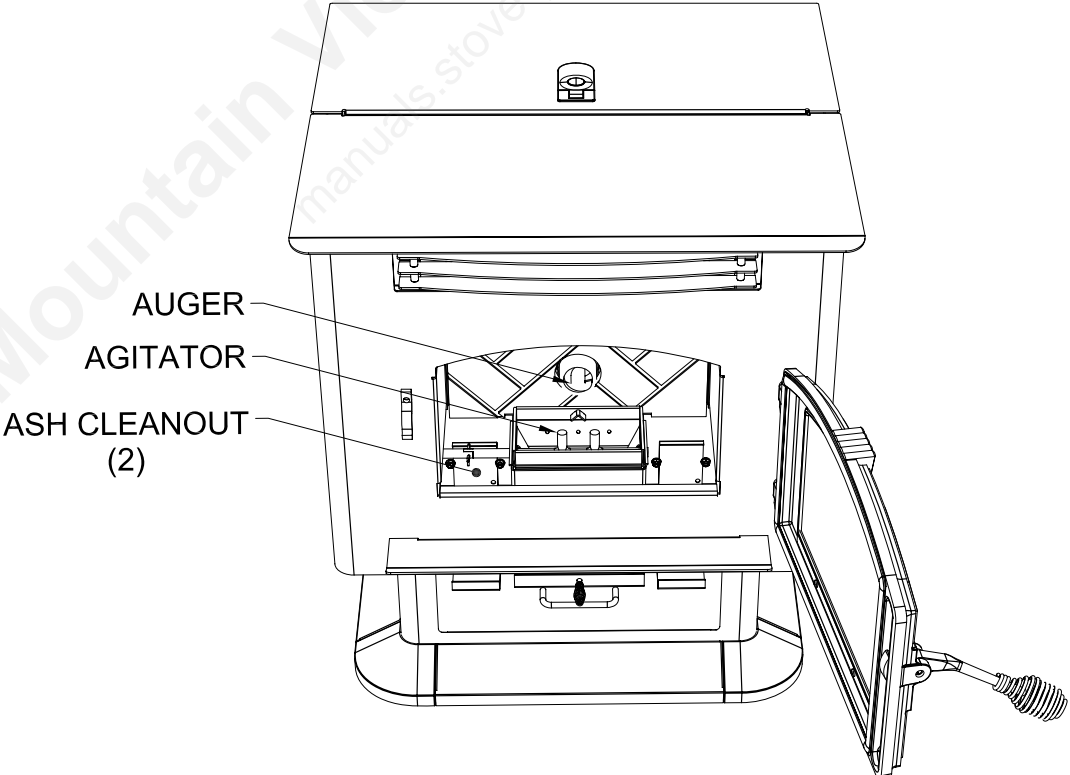
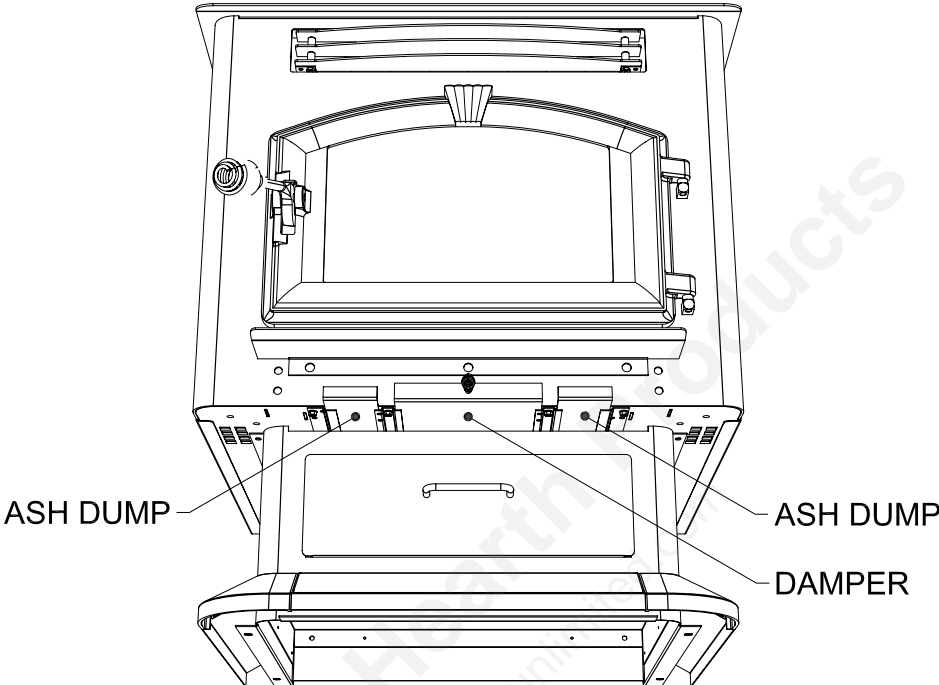

SAFETY STEPS

IMPORTANT: Proper installation of this stove is necessary for safe and efficient operation. Installing this product improperly may result in a house fire and personal injury. All applicable building codes for your location must be followed. In areas where building codes require additional steps to the installation of this product not included in this manual, the building codes will take precedent and must be followed. Contact your local building inspector to obtain any necessary permits or inspection guidelines before installing the product.

- The **American Harvest** stove is designed to burn dry shelled corn, cherry pits, or pelletized fuel such as wood pellets. The burning of other solid fuels such as cord wood or wood chips in this stove is not permitted.
- This product requires simple periodic maintenance for proper operation and long life of the stove. Read and follow the maintenance schedule closely.
- **DISCONNECT THE POWER CORD BEFORE SERVICING THIS STOVE!**
- **A power surge protector is required.** The unit must be plugged in to a **grounded** 110-volt power source. Circuit Boards are very expensive - protect yours!
- Always route the power cord away from the unit. Do not route cord in foot traffic areas. Do not pinch cord under furniture. Do not route the cord across the exhaust pipe.
- A working smoke detector must be installed in the same room as this product.
- Flammable or explosive liquids such as gasoline, naphtha, alcohol, lighter fluid, or engine oil must **NEVER** be used in or around this stove. These liquids must be stored well away from this stove as the open flame in the burner chamber could ignite the fumes of such liquids. Do not burn garbage in this unit.
- The moving parts of this stove are propelled by high torque electric motors. The Auger and Fuel Agitator can cause severe injury to body parts that may get near them. Keep all body parts away from the Auger and Fuel Agitator while the stove is plugged into an electrical outlet. These moving parts may begin to move at any time while the stove is plugged in.
- According to HUD requirements, when installed in a mobile home, this stove must be grounded directly to the steel chassis of the mobile home and bolted to the floor. Direct air access must be provided - Use 69FAK Fresh Air Kit
- This stove is not intended for use in commercial installations.
- Do not connect this stove to "B" vent. **Use UL Listed Pell Vent ONLY!**

BURNING SOLID FUELS

Ashes will have to be removed from the stove for proper operation. See cleaning procedure.

Your **American Harvest** stove, due to the nature of solid fuels, will require brief periodic attention. Please do not expect to light your stove and walk away from it. A few moments of adjustment and cleaning is an important part of burning solid fuels, due to the vast differences in fuel, humidity and outside temperature.

The **American Harvest** stove has been designed to burn dry shelled corn, wood pellets and other pelletized fuels that meet Association of Pellet Fuel Industries standards.

BURNING SOLID FUELS continued...

SHELLED CORN (Dry, preferably corn with 11- 12% moisture content)

- **Corn must contain less than 14% moisture content.** Wet corn will rapidly deteriorate stove components, reduce efficiency and void all warranties. Purchase a moisture tester if in doubt.
- Corn must be clean and free from debris. Never burn corn right from the field. Damage caused by dirty corn is not covered by the product warranty. Ask for clean **filtered** bagged corn only. Stalk parts, excessive fines and cob remnants will clog the auger. Check your corn for foreign objects.
- **NEVER BURN SEED CORN IN YOUR STOVE.** Seed corn is treated with chemical pesticides that are harmful or fatal if swallowed, therefore, seed corn is dangerous to have in the house, especially where children can reach it.
- Never burn "Deer Corn." It frequently contains molasses/sugars.
- Store your corn supply in a dry place and keep bags or container sealed to prevent your corn from absorbing excess moisture. Test the moisture content periodically to ensure the proper dryness.
- There are many varieties of corn grown around the world. Each variety has unique characteristics including the shape and size of the kernel. Your stove will burn more consistently with a small to midsize kernel corn. If the kernel size of the corn varies greatly or if you switch sources frequently, you will get a less consistent burn. Therefore, purchasing corn from the same source will help achieve a more consistent burn. **DO NOT USE CORN WITH A HIGH WAX CONTENT!**

WOOD PELLETS

- As with corn, be consistent in your pellet supplier. Pellets will vary in content and burn characteristics from supplier to supplier. A consistent supply of pellets will result in a more consistent and efficient burn.
- Check your pellets for foreign objects. Your stove warranty will not cover damage done to your stove due to foreign objects in the fuel supply.
- Store your pellets in a dry place to prevent them from absorbing added moisture.
- To decrease sawdust buildup, the hopper and auger tube will need to be vacuumed out after every 6-8 bags of pellets or more often if the pellets are poor quality. The hopper should be empty of fuel when this is performed. You may have to screen each bag of pellets if sawdust becomes a problem.
- Wood Pellets vary in size and ash content from less than 1% to 3% or more. Your stove will burn more efficiently with small to midsize pellets. Low ash content pellets will allow you to burn the stove longer between cleanings. Only wood pellets manufactured to the Association of Pellet Fuel Industries (A.P.F.I.) standard for residential pellets fuels are recommended. Performance will suffer if nonstandard pellets are used. Consult your local **American Harvest** reseller for more information on approved wood pellet fuel.

CAUTION:

DO NOT PLACE SUCH FUELS WITHIN THE SPACE HEATER'S INSTALLATION CLEARANCES OR WITHIN THE SPACE REQUIRED FOR FUELING AND ASH REMOVAL.

INSTALLATION REQUIREMENTS

FLOOR PROTECTION

The **American Harvest Multifuel Stove** may be installed on a combustible floor, **with proper floor protection**, or on a masonry hearth. The hearth or noncombustible floor protector must extend a minimum of (6) inches (152mm) in front and (6) inches (152mm) from each side of the unit.

CLEARANCES TO COMBUSTIBLES 6039(T)

The stove must be installed with the following minimum clearances to side and back wall combustible materials.

NOTE: These are minimum clearances to combustible walls established by the testing lab.

PARALLEL -	A - Sidewall to Top Edge of Unit	8 in./203mm
	B - Sidewall to Flue	13 in./330mm
	C - Backwall to Flue	3 in./75mm
	D - Backwall to Unit	9 in./228mm
CORNER -	E - Adjacent Wall to Flue	3 in./75mm
	F - Adjacent Wall to Unit	4 in./100mm

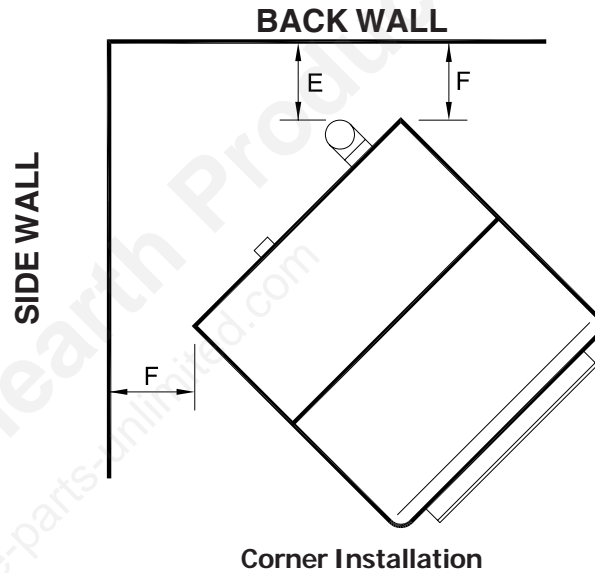
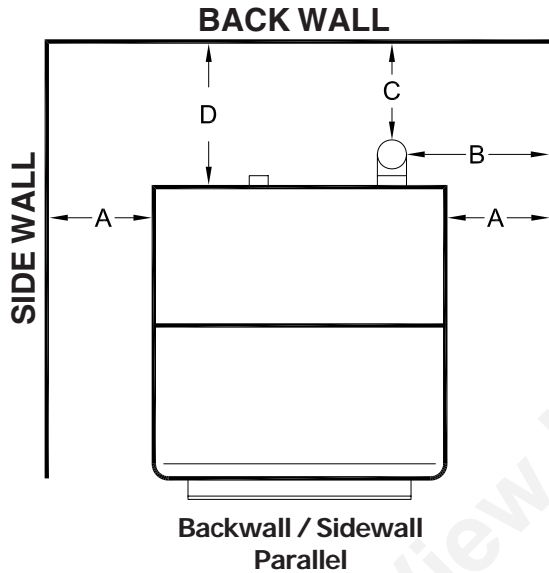

NOTE:
Allow sufficient space to remove the left and right side panels for maintenance purposes.

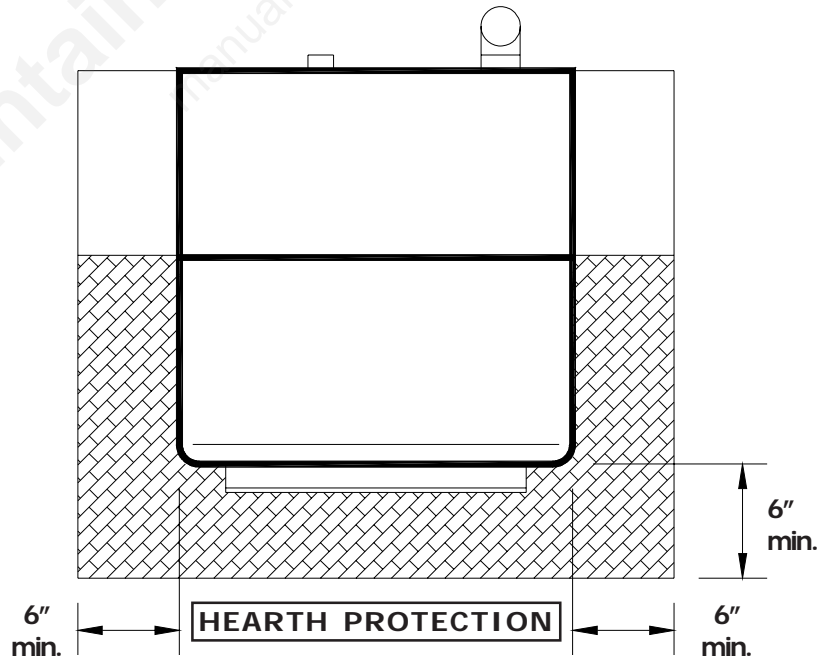

These clearances must be maintained and may only be reduced by means approved by the regulatory authority

CLEARANCES TO COMBUSTIBLES 6039I

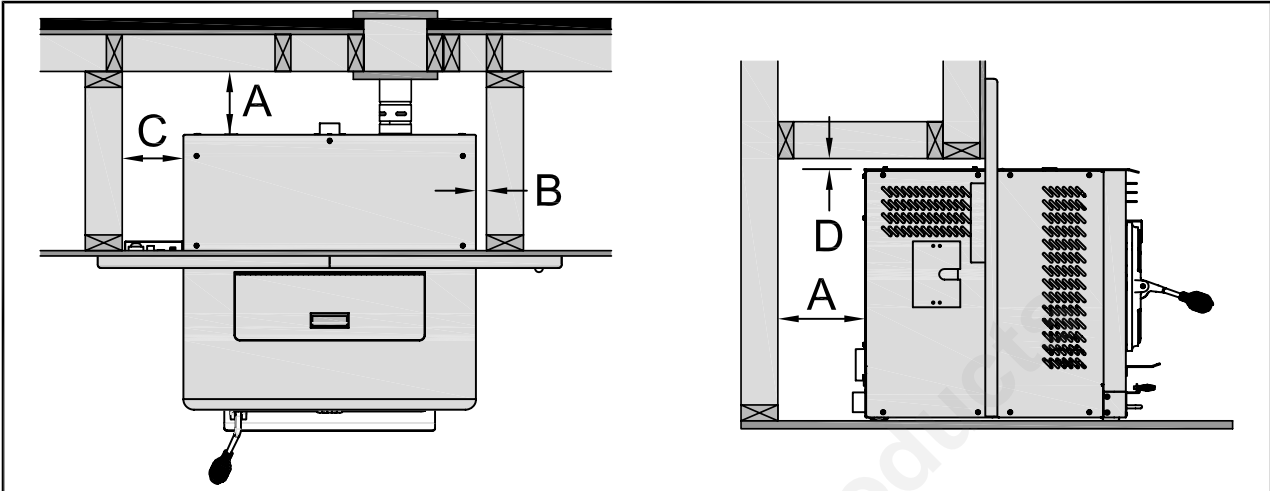

AS A BUILT-IN

KEY	AS A BUILT-IN	INCHES
A	BACK OF UNIT TO WALL	6
B	RIGHT SIDE OF UNIT TO WALL	1
C	LEFT SIDE OF UNIT TO WALL	6
D	TOP OF UNIT TO WALL	1

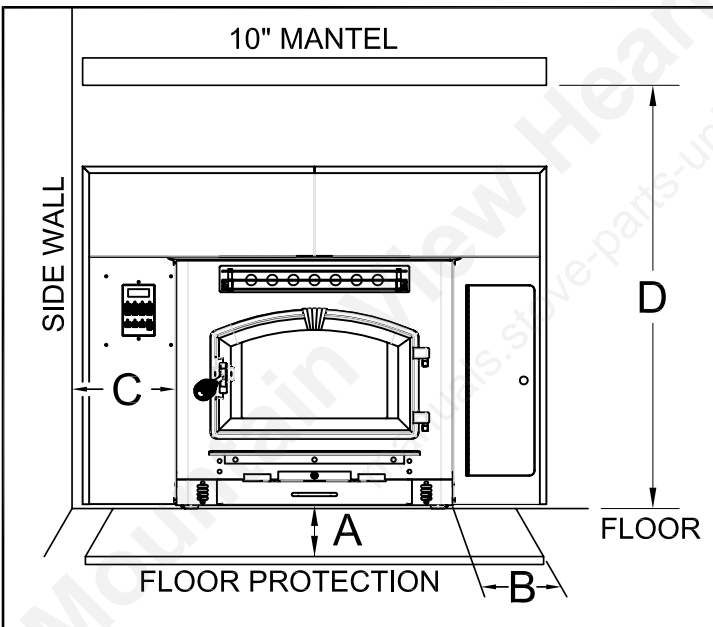

EXTERNAL CLEARANCE TO COMBUSTIBLES		
KEY	INCHES	INCHES
A	FLOOR PROTECTOR EDGE TO FRONT OF UNIT	6
B	FLOOR PROTECTOR EDGE TO SIDE OF UNIT	6
C	LEFT SIDE OF UNIT TO WALL	8
D	FLOOR TO MANTEL	53

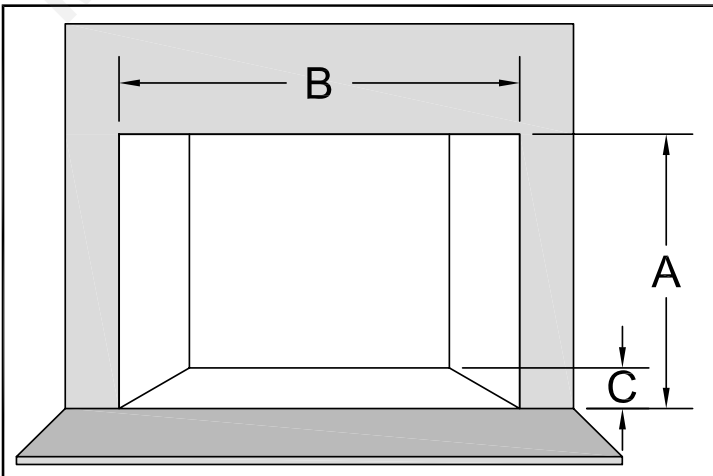

MINIMUM OPENING FOR MASONRY AND FACTORY-BUILT FIREPLACES		
KEY	INCHES	INCHES
A	HEIGHT	24
B	WIDTH	40
C	DEPTH	20

GUIDELINES FOR EXHAUST VENTING SYSTEMS DESIGN

It is recommended that only an authorized installer install your pellet/corn stove, preferably an NFI certified specialist. The following installation guidelines must be followed to ensure conformity with both the safety listing of this stove and to local building codes.

INSTALL VENT AT CLEARANCES SPECIFIED BY THE VENT MANUFACTURER.

- A UL listed 3" or 4" type "PL" pellet vent exhaust system must be used for installation and attached to the pipe connector provided on the back of the stove. Use a 3" to 4" adapter for 4" pipe. A cap must be used at the termination of type "L" vent chimneys. 4" PL is required for elevations above 2,500 feet above sea level.
- Do not terminate vent in any enclosed or semi-enclosed area, such as; carports, garage, attic, crawl space, under a sundeck or porch, narrow walkway or close area, or any location that can build up a concentration of fumes such as a stairwell, covered breezeway etc.
- Vent surfaces can get hot enough to cause burns if touched by children. Noncombustible shielding or guards may be required.
- **Do not install a flue damper in the exhaust vent of this unit.**
- Termination must exhaust above air inlet elevation. Installation MUST include three (3) vertical feet of pellet vent pipe. This will create some natural draft to prevent the possibility of smoke or odor during appliance shutdown and to keep exhaust from causing a nuisance or hazard from exposing people or shrubs to high temperatures. **Do not connect this unit to a chimney flue serving another appliance. Do not connect directly to a masonry chimney.**
- The installation must include a cleanout tee to enable collection of fly ash and to permit periodic cleaning of the exhaust system. 90° elbows accumulate fly ash and soot thereby reducing exhaust flow and performance of the stove. Each elbow or tee reduces draft potential by 30% to 50%. Use no more than 180 degrees of elbows (two 90-degree elbows, or two 45-degree and one 90-degree elbow, etc.) and one cleanout tee to maintain adequate draft. Cleanout tees and elbows should not be connected to the rear of the unit unless a 3-inch adapter is used.
- Total length of horizontal vent must not exceed 48"(4ft.)/1,200mm. The maximum recommended vertical venting height is 15-feet for 3-inch type "PL" vent. Anything more than 15-feet, 4-inch "PL" vent must be used. All joints in the vent system must be fastened by at least 3 screws, and all joints must be sealed with RTV silicone sealer to be airtight.
- The area where the vent pipe penetrates to the exterior of the home must be sealed with silicone or other means to maintain the vapor barrier between the exterior and the interior of the home.

NOTE: These are guidelines only. Proper venting is accomplished by design and common sense. In most installations 3 inch diameter venting is adequate. If it does not vent properly you will have to change it to 4 inches. You should not exceed 4 inch diameter venting.

DO NOT CONNECT TO ANY AIR DISTRIBUTION DUCT OR SYSTEM

VENT TERMINATION CLEARANCES:

- A) Min. 4-ft clearance below or beside any door or window that opens.
- B) Min. 1-ft clearance above any door or window that opens.
- C) Min. 3-ft clearance from any adjacent building.
- D) Min. 7-ft clearance from any grade when adjacent to public walkways.
- E) Min. 2-ft clearance above any grass, plants, or other combustible materials.
- F) Min. 3-ft clearance from a forced air intake of any appliance.
- G) Min. 2-ft clearance below eaves or overhang.
- H) Min. 1-ft clearance horizontally from combustible wall.
- I) Must be a minimum of 36-inches above the roof and 24-inches above the highest point or the roof within 10-feet.

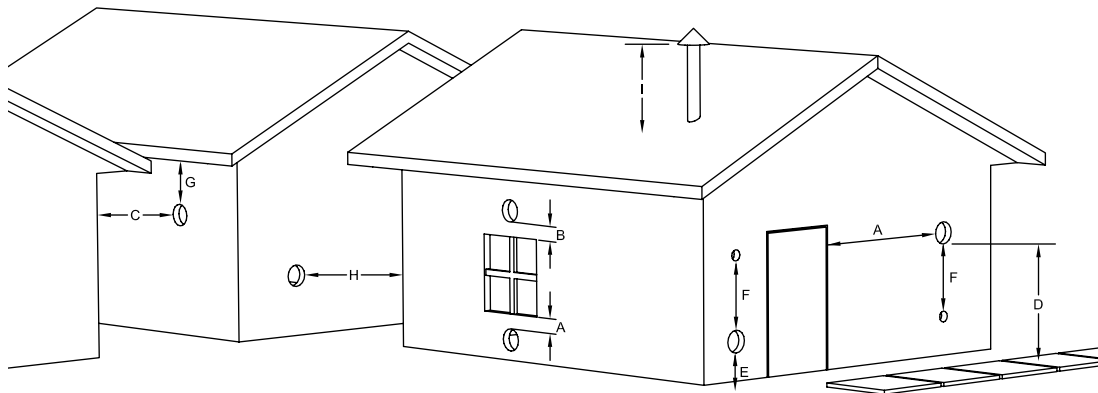

DESIGN GUIDELINES FOR OUTSIDE COMBUSTION AIR CONNECTION

- 1) For installations with horizontal through-the-wall exhaust, it is strongly recommended that the stove combustion air be connected to the outside. If the home is newer or has been tightly insulated, it is required to install outside combustion air.
- 2) Connection to outside the house is REQUIRED for mobile home installations. We strongly urge use of the 69FAK Fresh Air Kit.

90 DEGREE BEND TERMINATION

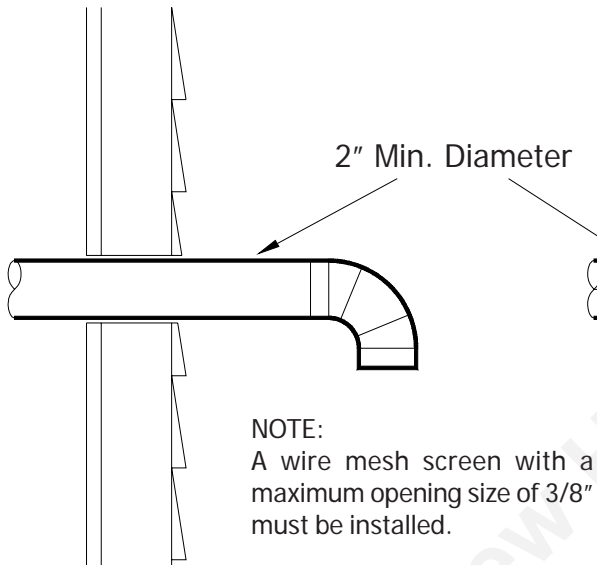

WIND HOOD TERMINATION

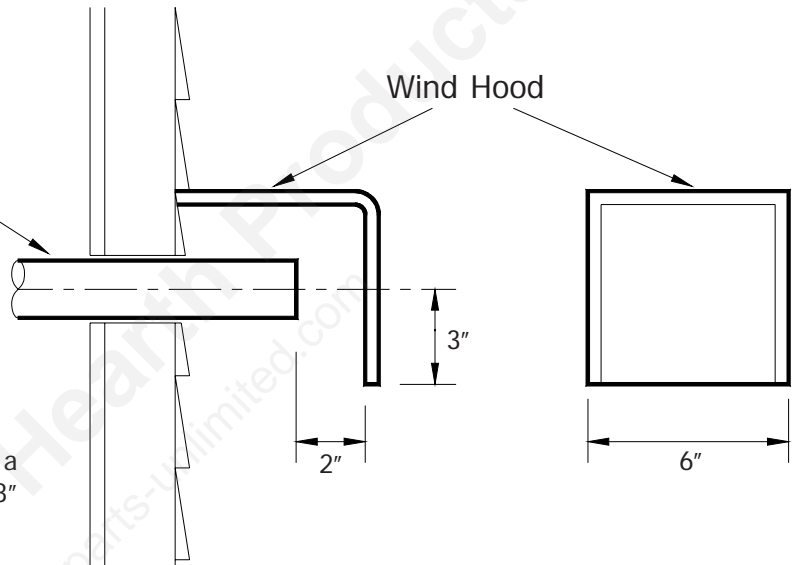

- 3) Only noncombustible pipe 2 inches (or greater) in diameter is approved to use for outside air connections (straight or flexible). PVC pipe is NOT approved and should NEVER be used.
- 4) If the air inlet is connected to the outside, it MUST be terminated with a vertical 90-degree bend (down) or with a wind hood. Failure to do so could result in a burn back during high winds blowing directly up the air inlet during a simultaneous power failure (see diagram above).
- 5) Blockage, excessive length, or extra bends in the air intake pipe will starve the stove of combustion air. A 90-degree bend is equivalent in restriction to approximately 30 inches of straight inlet pipe.

CAUTION: The operation of exhaust fans such as bath room fans, attic fans, etc. might starve the heater of combustible air creating a negative pressure in the room. Provide adequate ventilation in the room accompanying the heater. If not, the pressure switch may shut off operation of the heater. (Due to negative pressure)

INSTALLATION CONFIGURATIONS

Note: Where passage through a wall, or partition of combustible construction is desired, the installation shall conform to CAN/CSA -B365

The American Harvest Corn/Pellet Stove Model 6039/6039T may be installed as follows:

- 1) A freestanding unit

The American Harvest Corn/Pellet Stove Model 6039I insert may be installed as follows:

- 1) In a pre-fab firebox (Factory Built)
- 2) In an existing masonry fireplace
- 3) As a build-in

MOBILE HOME INSTALLATION REQUIREMENTS

IN ADDITION TO THE STANDARD INSTALLATION INSTRUCTION, THE FOLLOWING REQUIREMENTS ARE MANDATORY FOR INSTALLATION IN A MOBILE HOME:

WARNING
DO NOT INSTALL IN SLEEPING ROOM

- 1) Stove must be permanently bolted to the floor. Remove the Base Trim and bolt thru the base flange.
- 2) Stove must have permanent outside air source. (69FAK)
- 3) Stove must be permanently electrically grounded to the steel chassis of the mobile home.
- 4) All vertical chimney vent must have wall supports.
- 5) All exhaust systems must have a spark arrestor.

CAUTION
**THE STRUCTURAL INTEGRITY OF THE MOBILE HOME FLOOR, WALL AND CEILING/
ROOF MUST BE MAINTAINED.**
Check with your local building official as other codes may apply.

Note: Always check dimensions on unit before cutting hole in wall

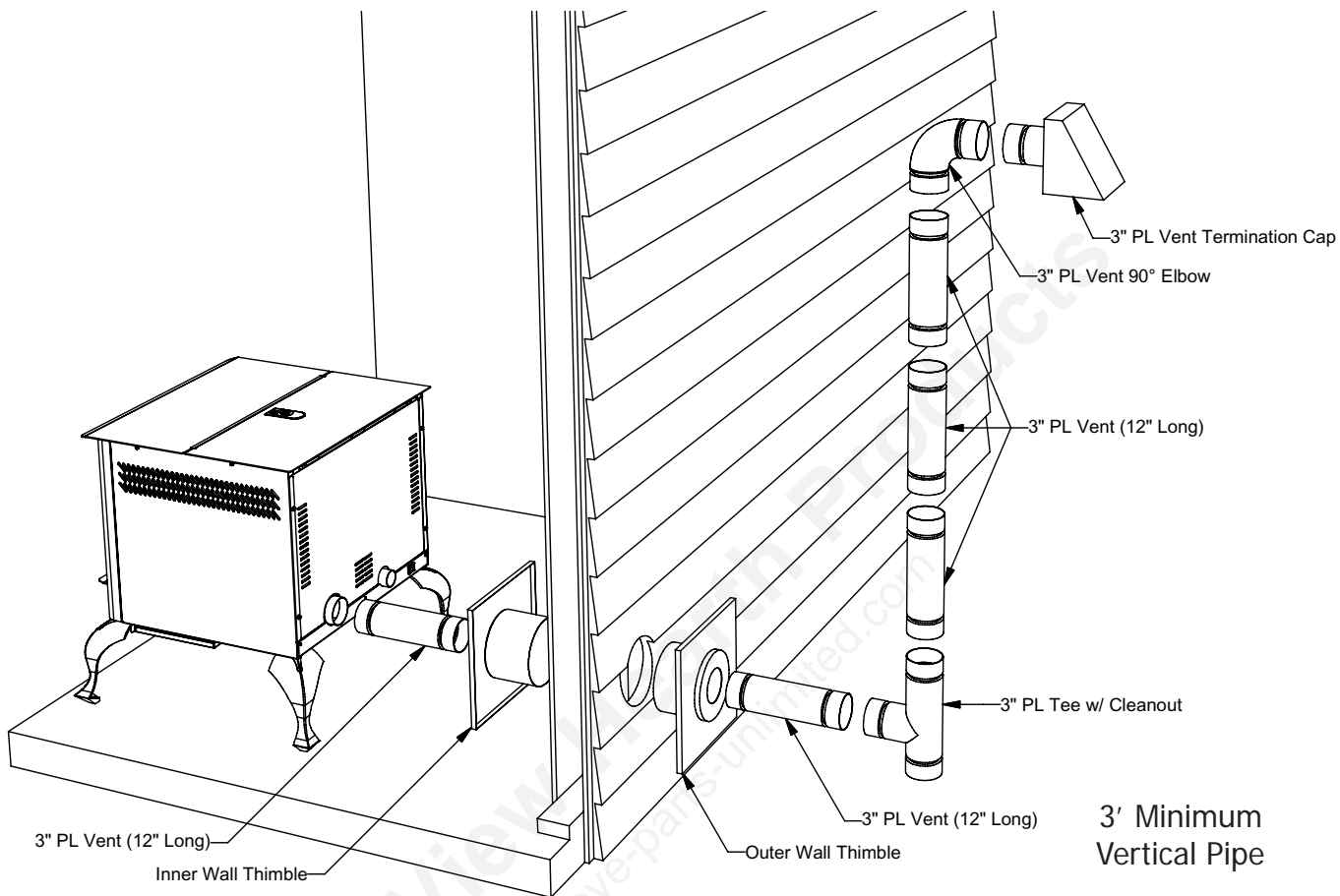

6039 - PEDESTAL UNIT

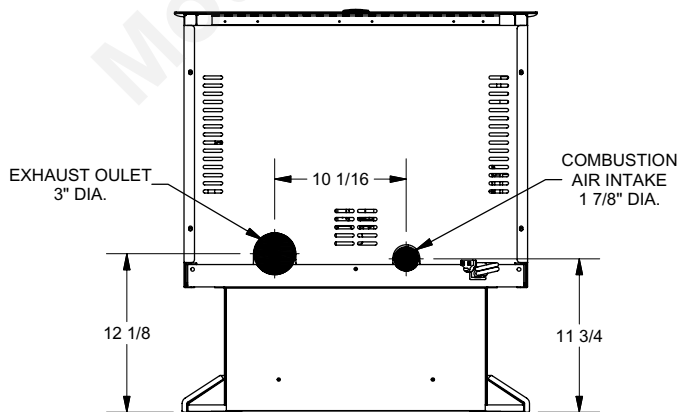

6039T - LEG UNIT

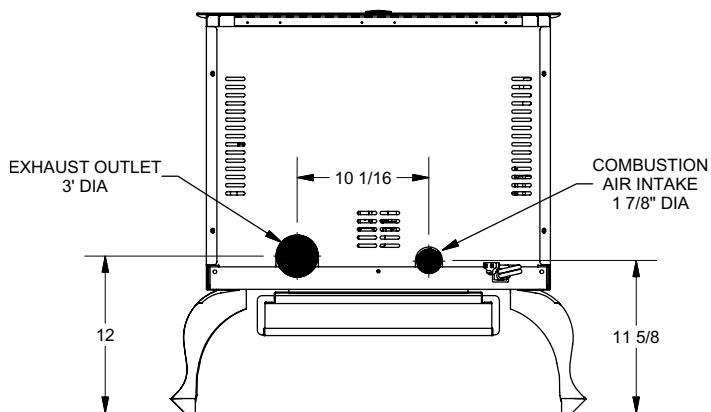

Dimensional tolerance
 $\pm 1/4"$

THROUGH THE WALL, VERTICAL PIPE INSTALLATION WITH TERMINATION CAP

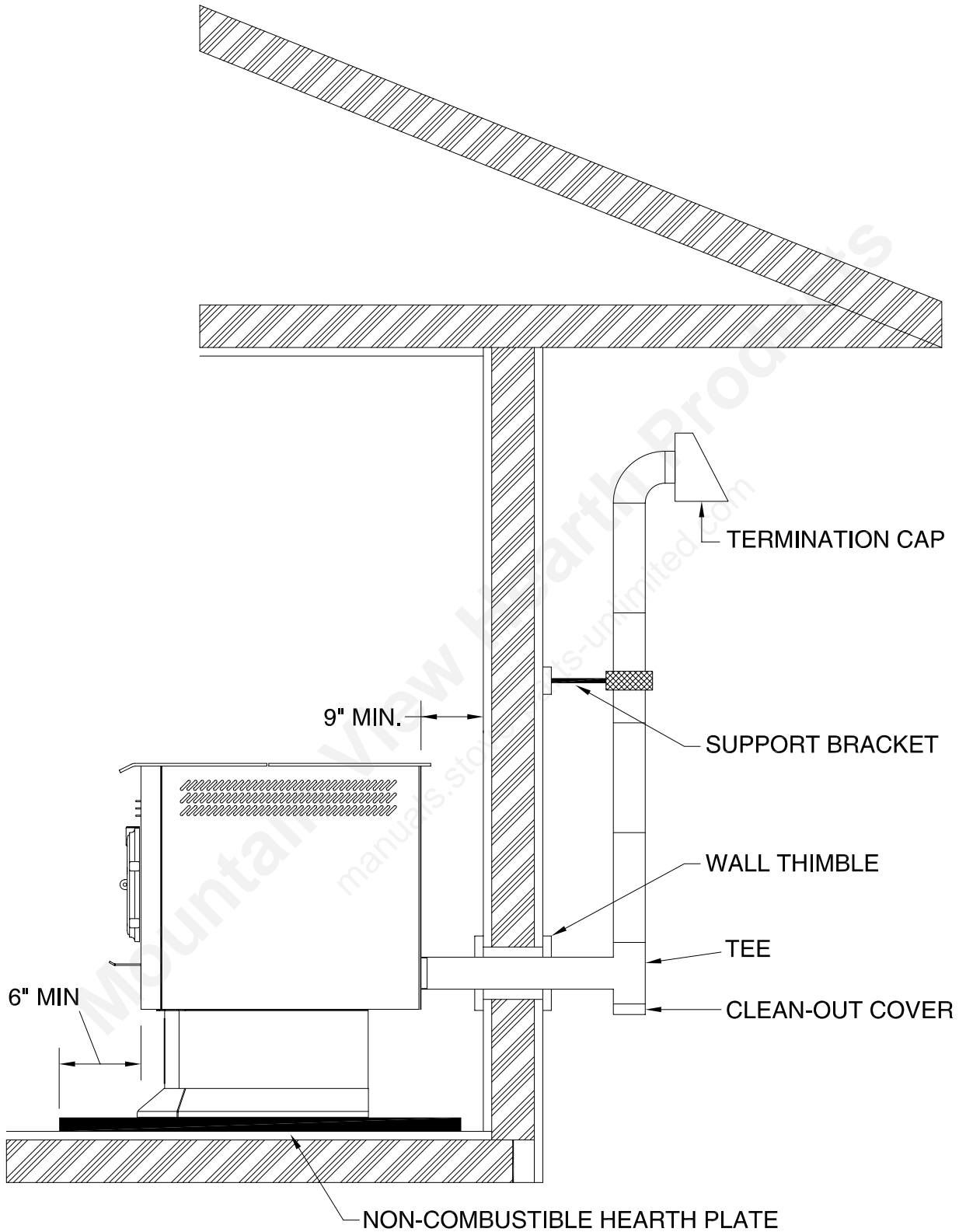

The Hearth Pad is not required under the unit if the floor is noncombustible but is required 6 inches (152mm) beyond the front of the unit and 6 inches (152mm) beyond each side of the door if the floor is a combustble floor. wood flooring, carpet, linoleum, etc.

DESIGN GUIDELINES FOR 6039I INSERT INSTALLATION

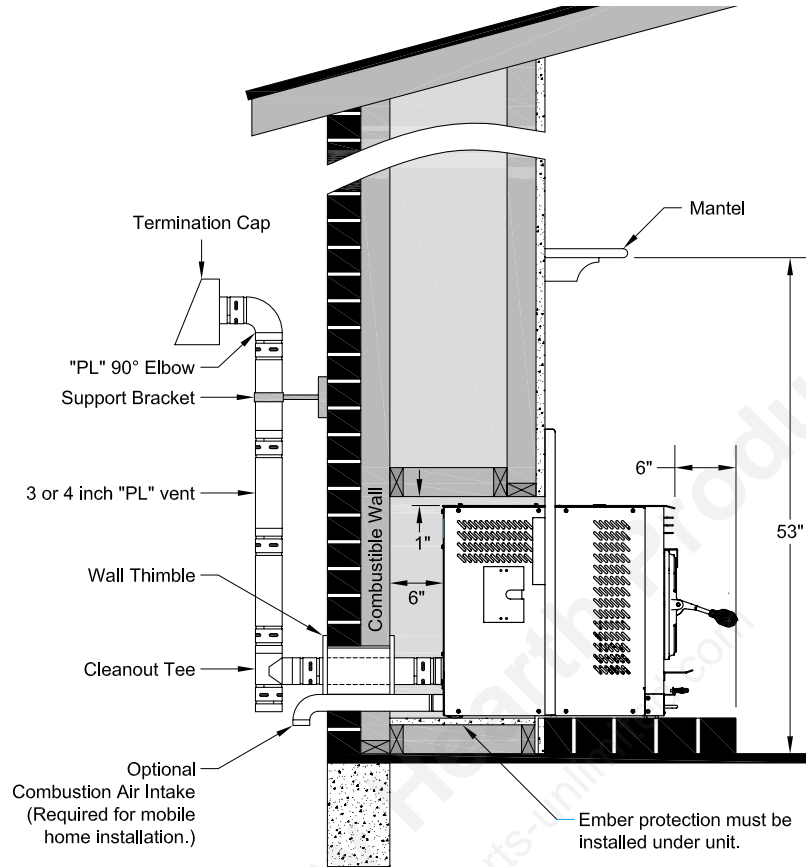

INSTALLATION AS A BUILT-IN FIREPLACE

A continuous sheet of non-combustible floor protection must be installed underneath the unit to prevent the possibility of embers falling through to the combustible floor. If the floor beneath the unit is of non-combustible material, the protector is not required.

See the "Clearance to Combustibles" section of this manual for installation clearances.

Alternative Exhaust Venting

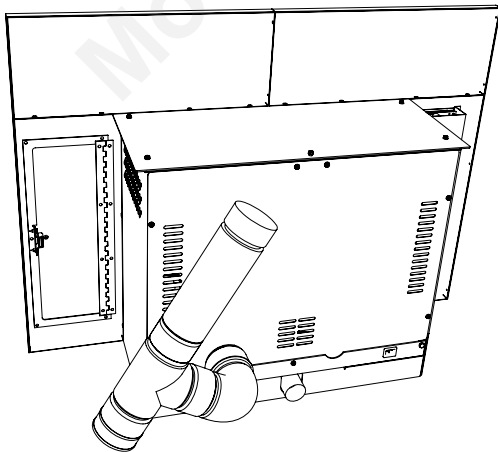

Depending on your installation, you might consider routing your cleanout tee as illustrated below for ease of cleaning. The access panel in the right side facade allows you to reach the tee from the front side of the unit if venting is assembled as shown. The cleanout tee is attached to a 90° elbow mounted to the unit then rotated at approx. 15-20 degrees. A 12 inch section of "PL" vent is connected to reach the top of the unit to which a flexible pipe may be attached for further termination through a chimney. Clearance to combustibles must be considered if this installation is chosen. A distance of 3 inches must be maintained from the exhaust vent to any combustible material.

DESIGN GUIDELINES FOR 6039I INSERT INSTALLATION

INSTALLATION INTO A MASONRY FIREPLACE

When installing into a masonry fireplace, DO NOT remove any bricks or masonry, with the following exception: masonry or steel, including the damper plate, may be removed from the smoke shelf and adjacent damper frame, if necessary, to accommodate a chimney liner. Do this only if their removal will not weaken the structure of the fireplace or the chimney, and will not reduce protection for combustibles to less than that required by national building codes.

Installation must include a chimney liner (3" or 4" Pell Vent "PL" Piping) that extends the full height of the chimney and meets type HT requirements. The liner must be securely attached to the insert and the chimney top. The chimney must be sealed either at the top or at the damper area with a non-combustible plate to prevent room air passage to chimney cavity.

Outside combustion air may be drawn through the chimney top or through an existing ash cleanout.

INSTALLATION INTO A FACTORY-BUILT (METAL) FIREPLACE

When installing into a zero clearance fireplace, The firebox must accept the insert without modification other than removing bolted or screwed together pieces such as smoke shelf/deflectors, ash lips, screen or door tracks, and damper assemblies. These items must be re-installed if the insert is removed and not replaced. The removal of any part must not alter the integrity of the listed fireplace in any way.

The factory built fireplace must be listed per UL 127. Installation must include a chimney liner (3" or 4" Pell Vent "PL" Piping) that extends the full height of the chimney and meets type HT requirements. The liner must be securely attached to the insert and the chimney top. The chimney must be sealed either at the top or at the damper area with a non-combustible plate to prevent room air passage to chimney cavity.

For raised hearth installations, adjust the leveling bolts under the front of the unit.

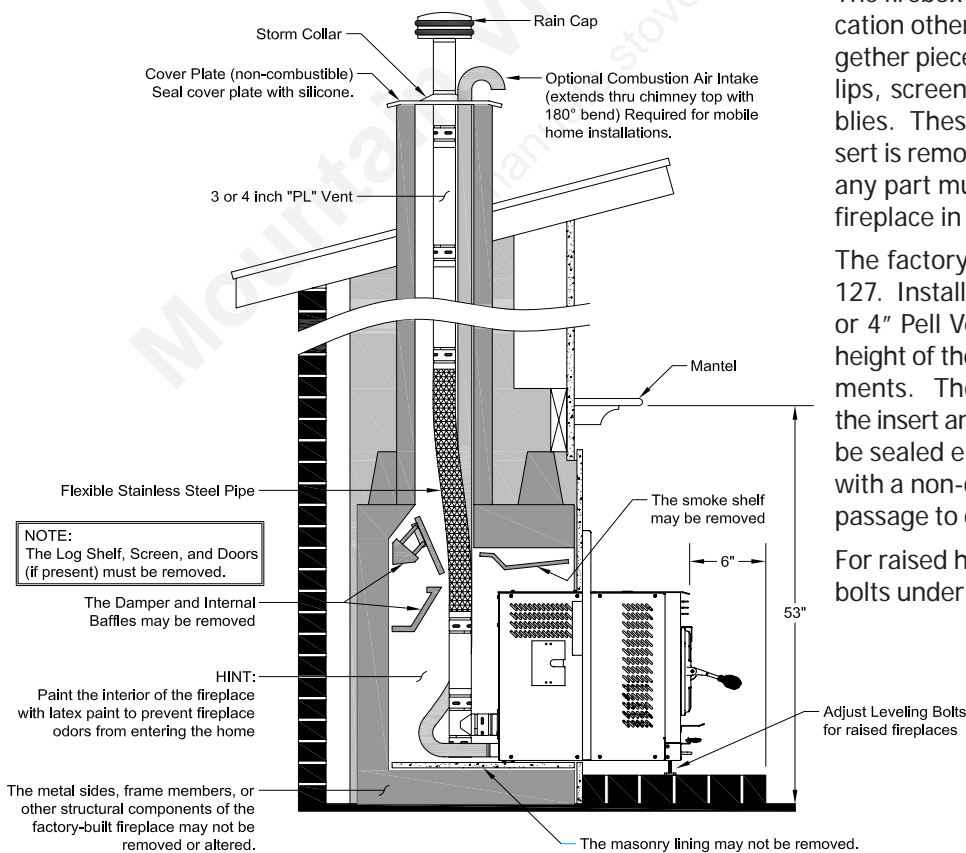
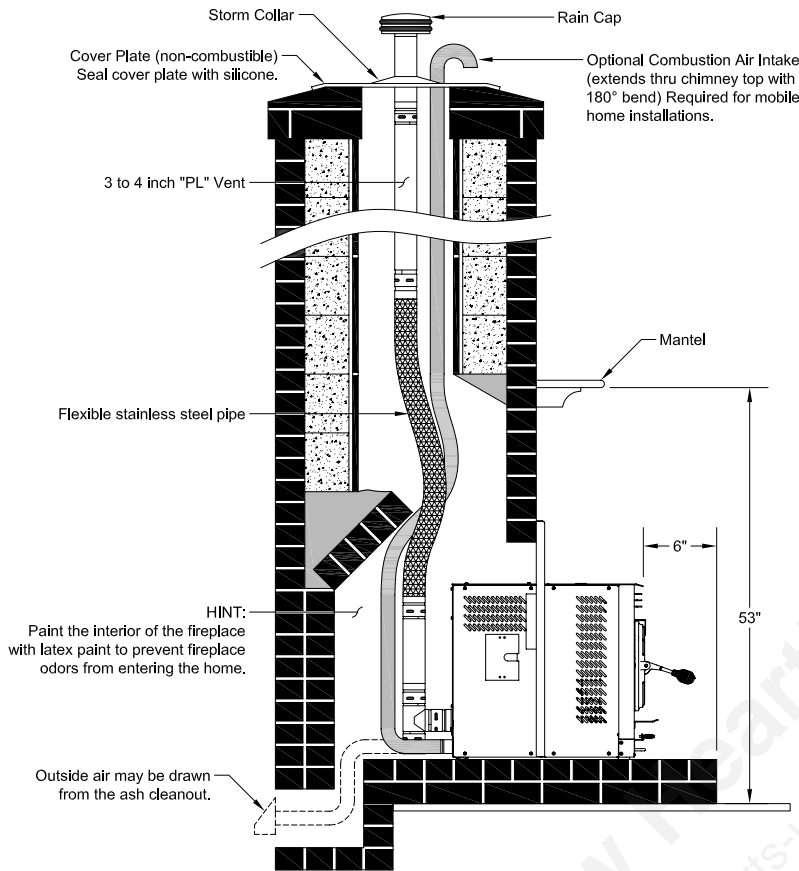

GLASS MAINTENANCE, REMOVAL AND REPLACEMENT

Your **American Harvest Corn/Pellet Stove** comes to you with the glass door installed in place, ready for use. The glass is surrounded on the edges with a gasket and seated in a glass channel. It is held in place with two (2) clips.

REMOVAL OF BROKEN OR DAMAGED CERAMIC GLASS

Open the door and lift off of hinges. If the door is tight, tap gently on the bottom of the door with your hand or rubber hammer. Lay door down on newspaper with glass clips facing you. Using a #2 Phillips screwdriver, loosen the screws and take off the glass clips. Remove the broken glass carefully and discard.

Reverse the above procedure for replacing new glass with new gasket. Do not over tighten the screws. Over tightening can cause the glass to break.

WARNING

- Do not operate unit with broken glass.**
- Do not substitute original factory glass.**
- You must use only factory authorized glass;**
- Do not slam door shut.**
- Do not strike glass.**
- Do not use abrasive cleaners.**
- Do not clean when glass is hot.**

CLEANING THE GLASS

When the fire is first started, it will produce some smoke. The smoke might accumulate on the glass surface. Before the fire gets hot, open the door and wipe the glass surface off with a rag. Do not touch the surface with your hands. If after constant use, the glass is dirty, you must clean the glass so that it will not become etched with the fly ash. When the glass has cooled off, take a damp rag, put a little fly ash from the unit on it and clean the glass. If this does not clean the glass use a non-abrasive spray; 409 or Windex works well. Do not use a rag that contains nylon because it will melt to the glass.



UNDERSTANDING THE CONTROL BOARD

CONTROL PANEL

Turning the heater OFF/ON, as well as adjustments for the fuel feed rate and room fan speed are performed by pressing the appropriate button(s) on the control panel which is located on the lower left-hand side of your **American Harvest** heater. The insert model 60391 is located on the left facade.

This unit can be changed between an automatic operation or a manual operation. The controller comes default in the automatic mode.

Pressing the “**ON**” button on the control panel will begin the start-up sequence for the heater. Fuel will begin to feed through the auger feed system after 3 minutes. Pressing and holding the “**ON**” button will rotate the auger continuously until button is released, which feeds additional fuel.

Pressing the “**OFF**” button on the control panel will cause the heater to enter its shut-down sequence. The fuel feed system will stop pulling fuel from the hopper and, once the fire goes out and the heater cools down, the fans will stop running.

Pressing the “**Heat Range**” arrows, up or down, will adjust the amount of fuel being delivered to the burnpot.

The draft fan (exhaust) will come on as soon as the “**ON**” button is pressed. The fan will automatically adjust its speed in accordance to the heat range setting. However, this speed can be manually operated by pressing the “**Draft Fan**” arrows up or down. “**Draft Fan**” when pressed, the display will show “Df-A”, which is automatic. Press the arrows again to adjust fan speed. When the heater is in the manual mode, the optional thermostat will not properly control the unit. When adjusting the Draft Fan setting, try only 1 setting above or below the heat setting. It is better to leave the stove in the automatic mode and adjust the manual draft slide to control the combustion air.

The room fan will come on once the unit has reached operating temperature (110°F). By pressing the “**Room Fan**” buttons, the display will show “Rf-A” which is automatic or “Rf-1” through “Rf-9” for manual settings. In auto mode, the room fan’s speed will automatically be adjusted in accordance with the heat range setting. By pressing the “**Room Fan**” up arrow, you can adjust the fan speed setting up to “Rf-9”. The fan speed can be adjusted to a higher setting than the heat setting but not lower.

The “**Aux**” button is for Agitator operation. When the unit is “**OFF**” and the stove is cool, pressing the “**Aux**” arrows will rotate the agitator for easy removal for cleaning. The agitator, when in Automatic mode, will operate at set intervals. However, these can be changed by pressing the arrows on the “**Aux**” button. The agitator can be adjusted from 0 to 9, setting “0” is off and setting “9” is high.

The “**Auger Delay**” button can be used to pause rotation of the Auger and Agitator for approx. 1 minute. This can be cancelled by pressing the “**ON**” button. The “**Auger Delay**” is normally used only during the start up cycle to slow the fuel delivery down during the initial ignition.

The “**Mode**” button is used to switch between manual and automatic mode. When in auto mode, the fan, auger, and agitator will operate at preset intervals unless changed manually using the buttons mentioned above. When in manual mode, the draft fan (exhaust) will operate at full speed (100%), so the air must be controlled with the manual slide damper just below the viewing door.

During normal operation, the unit is constantly monitored for problems. In the event of an error condition, the unit will stop and an error will be displayed. See the list of error codes found at the end of this manual.

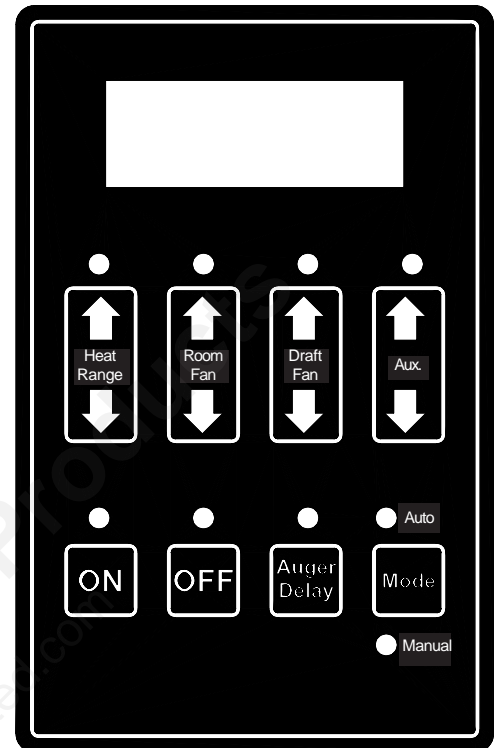

LIGHTING INSTRUCTIONS

CAUTION: DO NOT USE CHEMICALS OR FLUIDS TO START THE FIRE HOT WHILE IN OPERATION. KEEP CHILDREN, CLOTHING AND FURNITURE AWAY. CONTACT MAY CAUSE SKIN BURNS.

Before lighting your heater for the first time, make sure that all items are out of the hopper, ash pan and firebox area. Press the "On" button and allow your heater to run for at least 4 minutes, to check for proper operation. Once your heater is started, you will notice the draft fan starts immediately. If you press the "Heat Setting" button up, the draft fan changes speed, increasing speed the higher the heat setting. After 3 minutes, the auger and agitator will start rotating. **Note:** The room fan will not operate at this time, as a temperature of at least 110 degrees must be reached before operating. If proper operation of your heater is confirmed, you can add fuel to the hopper and allow the auger to purge the fuel to the firepot.

TO START:

- Turn the Heater to the "OFF" position and place a small handful of wood pellets or fire starting pellets (Pellets that already contain fire starter) in the firepot.
- Squirt only a small amount of fire starter gel on top of the wood pellets (NOT necessary if using fire starting pellets).
- Light the fire starter and wait approx. 1-minute for it to start actively burning.
- Press the "On" button, adjust the heat setting to read "Hr-2" and pull the damper out approximately 1 inches for this heat setting. This will automatically match your feed rate with the proper combustion air. As you increase the heat setting, your feed rate and combustion air increase together.

NOTE: Even if you are burning corn or other fuels in your unit, wood pellets make an excellent source of starter fuel. Corn takes too much starter to get lit and up to temperature.

- Three minutes after turning the stove "On", the auger will begin feeding fuel into the firepot along with the agitator turning. You should have the starting fuel completely burning in the firepot as the agitator rotates. NOTE: If the starting fuel is not burning hot enough, you may see the fire begin to go out as new fuel is being added. If this occurs, pressing the "Auger Delay" button will allow the auger to pause for 1 minute. Pressing the "ON" button will resume the auger if 1 min. is too long. If not enough fuel is the reason for not burning, pressing and holding the "ON" button will allow the auger to run continuously until you release the button.
- Once the fuel starts burning aggressively, you can adjust the heat setting to your desired range. Make sure that you pull the damper out approximately 1 inch. It may need to be pulled out more for higher heat settings. Try opening a 1/4 inch at a time.

As you begin to have better understanding of how the heater operates and the amount of heat you require, you can adjust the heat settings up or down to your satisfaction.

Never use gasoline, gasoline-type lantern fuel, kerosene, charcoal lighter fluid, or similar liquids to start or "freshen up" a fire in this heater. Keep all such liquids well away from the heater while it is in use.

Overfire Protection - If the heater is being overfired, burned too hot, the heater will automatically shutdown to avoid damage to components in the heater. Refer to "Lighting Instructions" for proper use.

Turning the stove off

Pressing the OFF button will cause the stove to enter a shutdown mode. If the stove has reached operating temperature, the OFF Indicator will blink until the shutdown procedure succeeds in lowering the stove temperature. The Room Fan will stay on to cool the stove, and the Exhaust Fan will stay on to remove smoke and heat from the combustion chamber. The Agitator will stop. The Auger will bump the fuel out of the auger every few seconds to prevent the fuel in the auger from burning. Once the temperature of the burn chamber falls below about 100 degrees F and the pressure switch detects that the door is closed, the fans will stop and the Auger will run for a few seconds to purge the auger system of any burned fuel. At this point, the OFF Indicator will go out and the stove will turn completely off. If during burning, the stove has reached at least 120 degrees F, the shutdown procedure will also include a 15 minute shutdown timer that will keep the stove in the shutdown state for at least 15 minutes regardless of whether it is cool or pressure is detected. The 15 minute timer can be turned off by pressing the off button during shutdown. This will cause the system to exit shutdown and return to the "OFF" mode as soon as the door is closed and the stove is cool.

DISPOSAL OF ASHES

Disposal of Ashes

Ashes should be placed in a metal container with a tight fitting lid. The closed container of ashes should be placed on a noncombustible floor or on the ground, well away from all combustible materials, pending final disposal. If the ashes are disposed of by burial in soil or otherwise locally dispersed, they should be retained in the closed container until all cinders have been thoroughly cooled.

MAINTENANCE INSTRUCTIONS

Soot and Flyash - Formation and Need for Removal

The products of combustion will contain small particles of flyash. The flyash will collect in the exhaust venting system and restrict the flow of flue gases. Incomplete combustion, such as occurs during startup, shutdown, or incorrect operation of the room heater will lead to some soot formation which will collect in the exhaust venting system. The exhaust venting system should be inspected at least once per month (of heavy use) to determine if cleaning is necessary. Corn has a high ash content.

Daily Maintenance

- **Surfaces on the front of the stove will be extremely hot during operation.** Always wear heat resistant gloves to perform periodic maintenance.
- Using a wooden stick, tap the side heat exchangers that are located on the left and right sides of the firebox. When you open the door, they are located directly inside to the left and right. When you tap the sides with the wooden stick the loose fly ash will drop out of these holes.
- Inspect inside stove for excessive ash build up. You will learn some fuels produce more ash than others. If excessive, remove the inside ash clean-outs. Once you have cleaned out the ashes, replace the clean-outs. Depending on your fuel and use, these clean-outs may be removed only weekly.
- If clinkers develops in the firepot, clean thoroughly. You may have to do this once or twice a day depending on the moisture content of the corn. If this is not cleaned out, it could cause the agitator to jam. USSC highly recommends an additive (see Fuel Additive) be added to your corn to eliminate these clinkers. Contact your local Feed and Seed for availability and cost. You will need this additive if the agitator "fingers" develop an accumulation or build-up.
- The clinkers on the agitator and burnpot are easily removed when soaked in warm water for 10 minutes.
- The ash pan (especially the model 60391) should be cleaned out on a daily basis or as needed depending ash build-up.

SPECIAL CLEANING/OPERATIONAL INSTRUCTIONS:

After cleaning or when operating the stove, you need to make sure that "both" clean-outs are in their proper position. If left out or placed incorrectly, the combustion air is effected greatly and the stove will not burn properly.

Also, make sure that the ash dumps on each side of the damper are pushed in completely. This will also effect the combustion air.

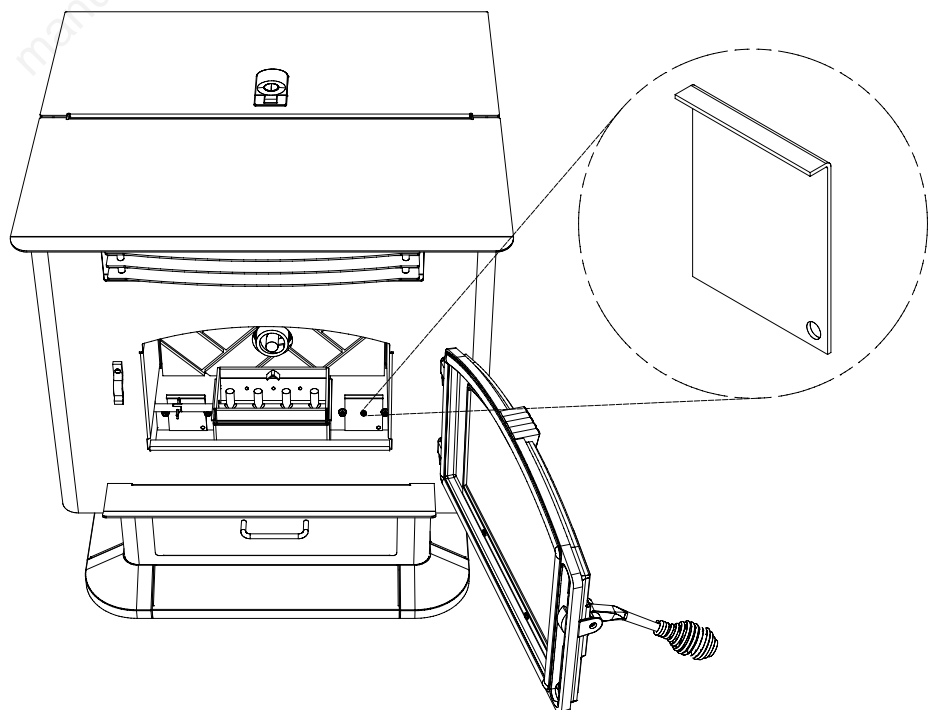

Weekly Maintenance

- Shut down the stove as directed in the operating instructions. Allow the stove to cool to room temperature. Remove the small clean-out slides in the lower corners of the firebox. Tap the sides of the burn chamber with a wooden stick. Do not tap the firewall behind the burn box as it may damage the insulation. Scrape the fly ash from the clean-out chambers toward the front of the burn chamber. Remove the fly ash from the burn chamber and replace the clean-outs.
- Remove the ash pan and dump the ash into a metal container.
- Cleaning of the exhaust system will depend upon the ash and debris content of your fuel. If your fuel has a high ash content and/or significant debris in it, your exhaust system will require weekly cleaning. Cleaner fuels will allow for monthly cleaning of the exhaust system. Remove the exhaust pipe from the back of your stove and remove any ash that may have collected in the pipes. Replace the pipes to the stove and seal with high temperature seal tape. If you have installed proper clean out tees you will not have to take the chimney sections apart.

REMEMBER: A clean unit burns efficiently and will remain trouble free!

SPRING CLEANING:

When the heating season is over make sure that you clean out all of the fuel in the hopper, firebox area, ash pan and firepot area. Corn and any ash can accumulate moisture over the summer months causing the unit to rust and the fuel to mold. Corn left in the unit will attract mice and can cause internal wiring and insulation damage.

It is recommended that prior to shutting down the unit in the spring, run the unit on the higher settings for a day to help clean out the heat exchanger system, venting system and firebox area.

When the unit is cleaned out, take the venting apart, clean out the fly ash, rinse the venting out with a water hose and let dry, take the draft fan off and clean, clean out all areas such as back heat exchanger and lubricate the auger, auger tube, firepot area, agitator shaft and bearings and hopper area with a light oil (something like Pam cooking oil works great to coat the inside of the unit and the moving parts). Clean the glass, doors and outer cabinet so that you are ready for the next heating season. Use of a wet/dry vacuum makes all cleaning easier.

AUTOMATIC SAFETY FEATURES

WARNING

These automatic safety features must not be bypassed

- **Power Outage**
During a power outage, the stove will shut down. It will not automatically restart when the power returns, unless the stove is still above the proper operating temperature and a flame still exist in the burnpot.
- **Overheating**
A high temperature switch will automatically shut down the stove if it overheats. The stove will need to be manually relit. Allow 45 minutes before relighting.

FUEL ADDITIVE

Chicken Scratch for my Corn Burner?

Yes - Crazy as it may sound, ground Oyster Shells, (calcium carbonate) same as fed to chickens, is the ideal additive to promote clean burning, especially when the Corn Fuel is extra high in starch. And it's available at your local Feed and Seed.

The "average" mixture is 1/2 pound of Oyster Shells (about 2 handfuls) to 60 pound of Corn, a full hopper. IF the "fingers" on your agitator (stirrer or rouser) have a noticeable buildup of "clinkers" or stubborn deposits, you have either a high starch fuel OR are burning with too much air for proper combustion and are reaching the "fusion" temperature of the Potassium and/or Starch in the Corn. You need Oyster Shells - and maybe more than a couple handfuls.

If you notice a heavy accumulation of "whitish powder" in your burn pot, reduce the amount of Oyster Shell Additive.

Remember, using this additive- as necessary - promotes efficiency (higher heat output), reduces maintenance, clinkers and ash content.

The mixing of hardwood pellets with corn also reduces clinker build-up. In addition, pellets will help wetter corn burn.

USSC

CIRCUIT BOARD FUNCTIONS

START-UP SEQUENCE OF EVENTS

Once the control panel is turned to on, a timer begins that will start, stop and continue operation of the **American Harvest** as a preset temperature is achieved.

COMPONENT	OPERATION START	OPERATION END
Draft Fan	Starts Immediately	Will continue until shutdown. Shutdown will occur when the operating temperature is below 90 degrees.
Agitator	Three minutes after starting the agitator will begin to turn	Will continue intermediately, as determined by the "HEAT SETTING", until shutdown
Auger	Three minutes after starting the auger will begin to turn	The auger will continue at the feed rate specified by the "HEAT SETTING". NOTE: Safety switches, HI limit and vacuum sensor, must be activated to continue proper operation.
Room Fan	Begins when 110 degrees is reached.	Will continue to operate until the heater cools down to below 90 degrees. This may take several minutes up to an hour.
Automatic Shutdown	If after 15 minutes, the heater has not reached the preset operating temperature, the unit will begin to automatically shut down.	Should the timer expire before the preset operating temperature is achieved, simply reset the stove by pressing the "ON" button.
Normal Operation	If after 15 minutes the preset operating temperature of 110 degrees is achieved, normal operation will continue.	Operation will continue until either the heater's control is to the "OFF" position, or the operating temperature falls below 90 degrees. At such time the heater will default to the "Automatic Shut Down".

SHUTDOWN SEQUENCE OF EVENTS

Once the **Heater** has reached the normal operating temperature and switched to the "OFF" position, the unit will continue to operate on a much lower setting for 10 minutes. (Approximately half of the "1" setting). After 10 minutes the auger will slow down further and continue at this feed rate until the heater's "LOW LIMIT SAFETY" sensor tells the control board it is safe to shutdown.

COMPONENT	SHUTDOWN	OPERATION END
Draft Fan	Unchanged operation until preset "OFF" temperature is achieved.	Continues until the operating temperature falls below 90 degrees. May take several minutes up to an hour.
Agitator	Continues at a lower sequence	Continues until the operating temperature falls below 90 degrees.
Auger	Slows down to a " <i>HALF SETTING</i> " for 10 minutes and then to a " <i>QUARTER SETTING</i> " for the duration of the shutdown.	The auger will continue at the lower feed rates until the operating temperature falls below 90 degrees. NOTE: Safety switches, HI limit and vacuum sensor, must be activated to continue proper operation.
Room Fan	Unchanged operation until preset "OFF" temperature is achieved.	Will continue to operate until the heater cools down to below 90 degrees. This may take several minutes up to an hour.
Automatic Shutdown	If the heater's "HI LIMIT" sensor snaps open, this will cause an automatic shutdown. An error code will be displayed (Err1). NOTE: "HI LIMIT" errors are usually the result of operating at the highest heat setting for long periods of time, room fan failure or loose wire connection.	It is rare that the HI LIMIT temperature is reached. However, should this error occur, let the heater cool down for an hour then restart.

ERROR CODES and DISPLAY INDICATORS

CAUTION: When performing any internal electrical maintenance

- Moving parts inside of the cabinet may cause injury. Do not operate unit with panels removed or open.
- **HOT** parts. Do not operate the unit with panel open.
- Risk of electric shock. Disconnect power before servicing unit.
- In the event of component failure, replace with the original factory equipment.

Error Code	Error Description	Possible Causes
Err1	The high limit temperature sensor has tripped.	<ul style="list-style-type: none"> • Inadequate ventilation. • Room fan failure. • Exhaust Blockage. • Electrical Open in the over temperature switch or wiring.
Err2	Stove ran out of fuel during normal operation.	<ul style="list-style-type: none"> • Hopper Empty. • Auger output failure or jam. • Flame or fuel quality caused fire to burn too slowly or go out. • Electrical Open in low temperature switch or wiring.
Err3	The stove was unable to reach the Room Fan On temperature within the startup time.	<ul style="list-style-type: none"> • Flame or Fuel quality caused the fire to burn too slowly or go out. • Auger output failure or jam Hopper empty on startup.
Err4	The power failed while the stove was hot, and when power was restored, the fire was out.	<ul style="list-style-type: none"> • Electrical Open in low temperature switch or wiring. • Power loss
Err5	The Auger output fuse has blown.	<ul style="list-style-type: none"> • Auger motor jammed or bad.
Err6	The Agitator output fuse has blown.	<ul style="list-style-type: none"> • Agitator motor jammed or bad.
Err7	The Draft Fan (Exhaust Fan) output fuse has blown.	<ul style="list-style-type: none"> • Draft Fan motor jammed or bad.
Err8	The Room Fan output fuse has blown.	<ul style="list-style-type: none"> • Room fan motor jammed or bad.

Display Indicators

Several situations or events are indicated in normal operation by blinking display indicators or segments in the display:

Flashing On Indicator: This means that the stove is in the “Start Up” state waiting for either a 3 minute timeout to begin burning or for the stove to reach the warm temperature whichever comes first.

Flashing Off Indicator: This indicates that the stove is in the “Shutdown” state waiting for the OFF button, or for a 15 minute period after the stove was turned off, or for the stove to cool down, or for the door to be closed.

Flashing dash in Heat Range Display: This indicates that the stove is in the normal run mode and is ramping from the current heat range setting to the target heat range setting. Once the ramp is complete, the dash will stop flashing. For ramping from heat range 1 to 9, the default time is 12 minutes (with a 90 second ramp time).

Flashing Automatic Mode Indicator: This indicates that the stove is in normal operation and is running in the automatic mode. However, either the Draft Fan or Auxiliary setting is manually configured.

Flashing Draft Fan Setting Indicator: This indicates that the stove is in normal operation and that the vacuum sensor detects a loss of pressure either because the door is open or because there is a negative pressure in the room with respect to the exhaust.

Factory Defaults

To return the control to its original factory default settings, press and hold the AUX UP and AUX DOWN buttons together for three seconds.

TROUBLE SHOOTING

Unplug stove before performing any maintenance

PROBLEM	CAUSE: Too rich air/fuel mixture	
<p>? Fire burns with a lazy, orange flame and/or fuel builds up in the firepot. Glass may become dirty.</p>	<ul style="list-style-type: none"> ✓ Make sure that the manual damper slide below the door is pulled out. (in the open position) ✓ Make sure glass door is shut and sealed tightly. If not, adjust door handle or replace gasket. ✓ Check that exhaust fan is running and venting properly. If not, check connection and clean or replace. ✓ Moisture content above 15%. Allow fuel to dry or mix with wood pellets. 	<ul style="list-style-type: none"> ✓ Check inside stove and exhaust pipes for blockage. Tap inside walls of firebox, clean behind lower access plates (located on the back inside wall, next to the firepot) clean firepot and firebox vent holes above firebrick panel. ✓ Feed rate is too HI for fuel, reduce heat setting. ✓ Inadequate combustion air available, add outside combustion air. (Optional kit 69FAK)
<p>? Fire goes out or stove shuts down. Fuel may stop feeding.</p>	CAUSE: Firepot burns out of fuel	
	<ul style="list-style-type: none"> ✓ Hopper empty, refill ✓ Door is open ✓ Auger jams. Remove auger and clean. (Auger jams can be a problem if poor quality fuel is used. Or excessive fines (sawdust, corn cobs or husk) are found in hopper. Auger jams are evident when there is no fuel delivered. 	<ul style="list-style-type: none"> ✓ The control board diagnostics will flash the light above Draft Fan for a Vacuum Switch error and display a "Err1" for a Hi Limit error.
<p>? Fire goes out or stove shuts down. Fuel may stop feeding.</p>	CAUSE: Auger stops turning	
	<ul style="list-style-type: none"> ✓ Auger has come loose. Check to see if auger motor is turning and auger is not. NOTE: Auger is held to the auger motor by a coupler that is fastened to the auger motor. Simply slide the auger into the auger housing and rotate until it fits into the coupler. ✓ Low limit sensor. If the operating temperature is too low the stove will shut down. 	<ul style="list-style-type: none"> ✓ Hi limit sensor. Evident when stove is extremely hot and the PCB displays an "Err1". Allow stove to cool for 1 hour and restart. ✓ Vacuum switch tripped. Caused by draft fan not running or venting blocked. Check fan, clean or replace. Clean venting of blockage. ✓ Auger motor not operating. Inspect connection and replace if necessary.

NOTE: Negative pressure in a home is a serious issue. All American Harvest appliances should be installed with the optional fresh air kit (69FAK).

WIRING DIAGRAM

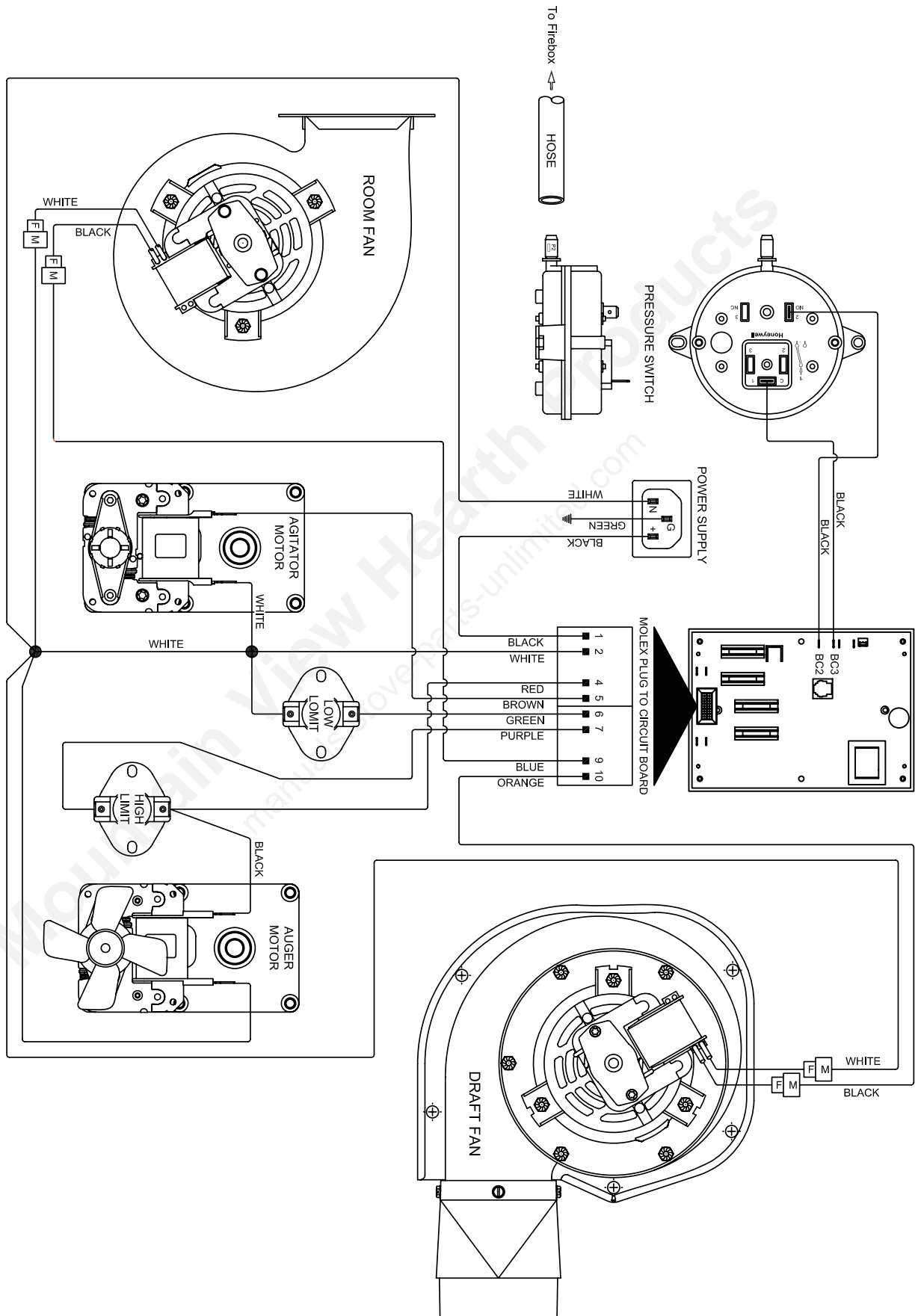

REPAIR PARTS DIAGRAM-6039

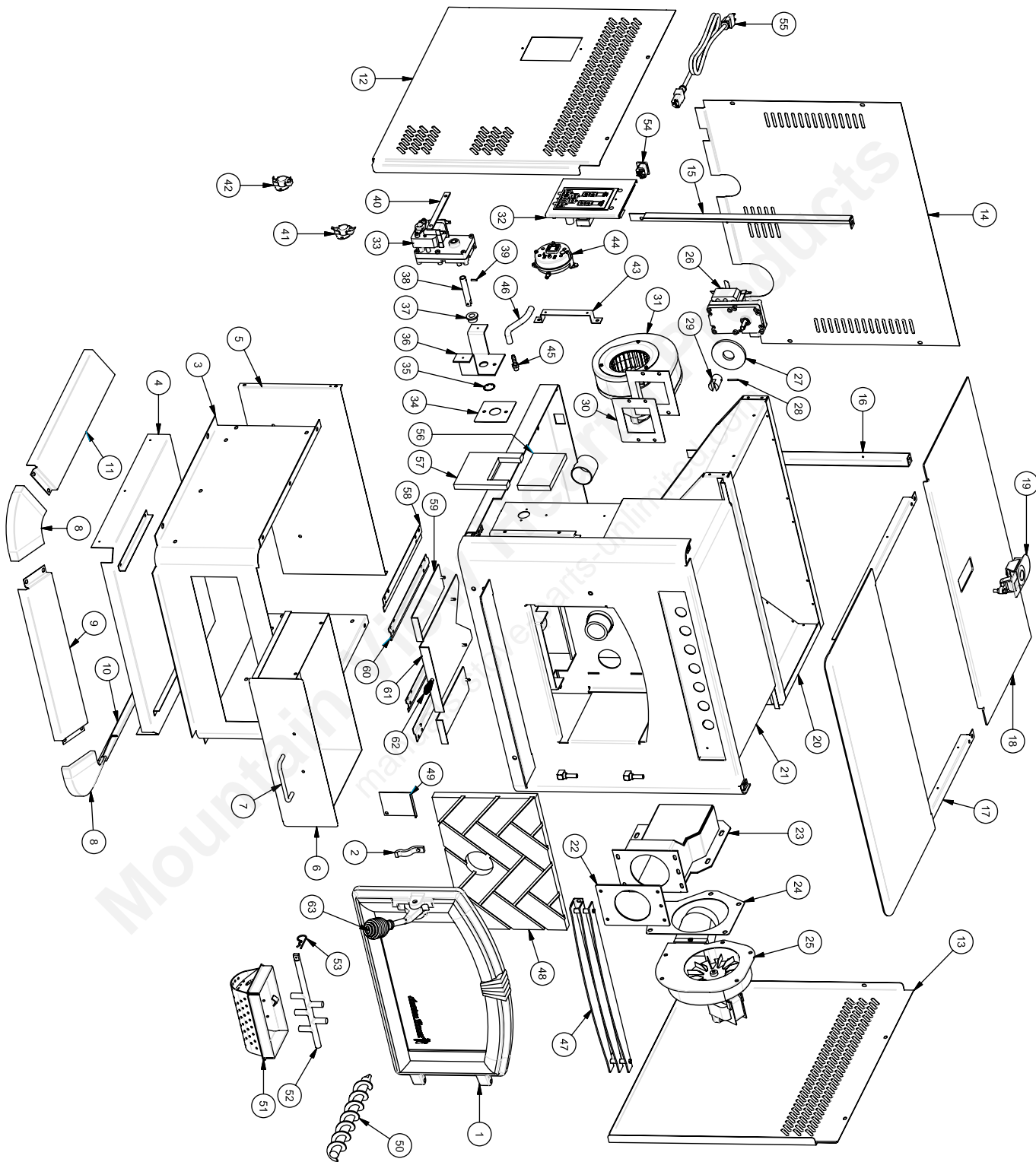

REPAIR PARTS LIST-6039

FOR MODEL: 6039	KEY	PART #	DESCRIPTION	QTY.
	1	69516	Feed Door Assembly	1
	2	25080MB	Latch, Door	1
	3	25409MB	Pedestal (6039)	1
	4	69508MB	Pedestal Bottom Weldment (6039)	1
	5	25451MB	Pedestal Back (6039)	1
	6	69478MB	Ash Pan Weldment (6039)	1
	7	891138	Handle, Brass	1
	8	25493	Corner, Trim (6039)	2
	9	25468MB	Pedestal Trim, Front (6039)	1
	10	25471MB	Pedestal Trim, Right (6039)	1
	11	25472MB	Pedestal Trim, Left (6039)	1
	12	25411MB	Cabinet Side, Left	1
	13	25412MB	Cabinet Side, Right	1
	14	25413MB	Cabinet Back	1
	15	25448	Support Frame (Back/Left)	1
	16	25447	Support Frame (Back/Right)	1
	17	69477MB	Top Weldment	1
	18	69503MB	Lid Weldment	1
	19	891125	Latch, Hopper Lid	1
	20	69499	Hopper Assembly	1
	21	88116	Insulation, Blanket	1
	22	88114	Gasket, Exhaust Duct	1
	23	69498	Exhaust Duct Weldment	1
	24	88100	Gasket, Draft Fan	1
	25	80473	Fan, Draft	1
	26	80456	Auger Motor	1
	27	83511	Washer, Rubber	1
	28	83533	Roll Pin, 1/8" dia X 7/8"	1
	29	891136	Coupling, Shaft	1
	30	88106	Gasket, Room Fan	1
	31	80472	Fan, Room	1
	32	80507	Circuit Board	1
	33	80488	Motor, Drive	1
	34	88111	Gasket, Agitator Bracket	1
	35	83534	Ring, Retaining	1
	36	25422	Bracket, Agitator/Bushing	1
	37	891132	Bushing, Agitator	1
	38	86620	Shaft, Agitator Drive	1
	39	83901	Roll Pin	1
	40	25427	Retainer, Agitator Motor	1
	41	80381	Low Limit Switch (F110 Thermodisc- 60T12)	1
	42	80455	Auger Safety Switch (F250 Thermodisc- 60T11)	1
	43	25443	Bracket, Pressure Switch	1
	44	80478	Switch, Pressure	1
	45	89586	Nipple, Auger	1
	46	891121	Hose, Silicone	5 Inches
	47	69497MB	Louver Assembly	1
	48	891139	Ceramic Brick	1
	49	25524	Cleanout, Ash	2
	50	891054	Auger	1
	51	891297	Burnpot	1
	52	891059	Agitator	1
	53	83529	Hairpin	1
	54	80462	Receptacle, 3 Prong	1
	55	80461	Power Supply Cord	1
	56	88121	Insulation Top - Agitator	1
	57	88122	Insulation Bottom - Agitator	1
	58	891224	Cleanout Guide	2
	59	891223	Cleanout, Ash (Lower)	2
	60	891225	Cleanout/Damper Guide	2
	61	891226	Weldment, Damper	1
	62	89954	Spring Handle	1
	63	89574	Spring Handle (Feed Door)	1
	N/S	80485	Wiring Harness	1

REPAIR PARTS-6039I

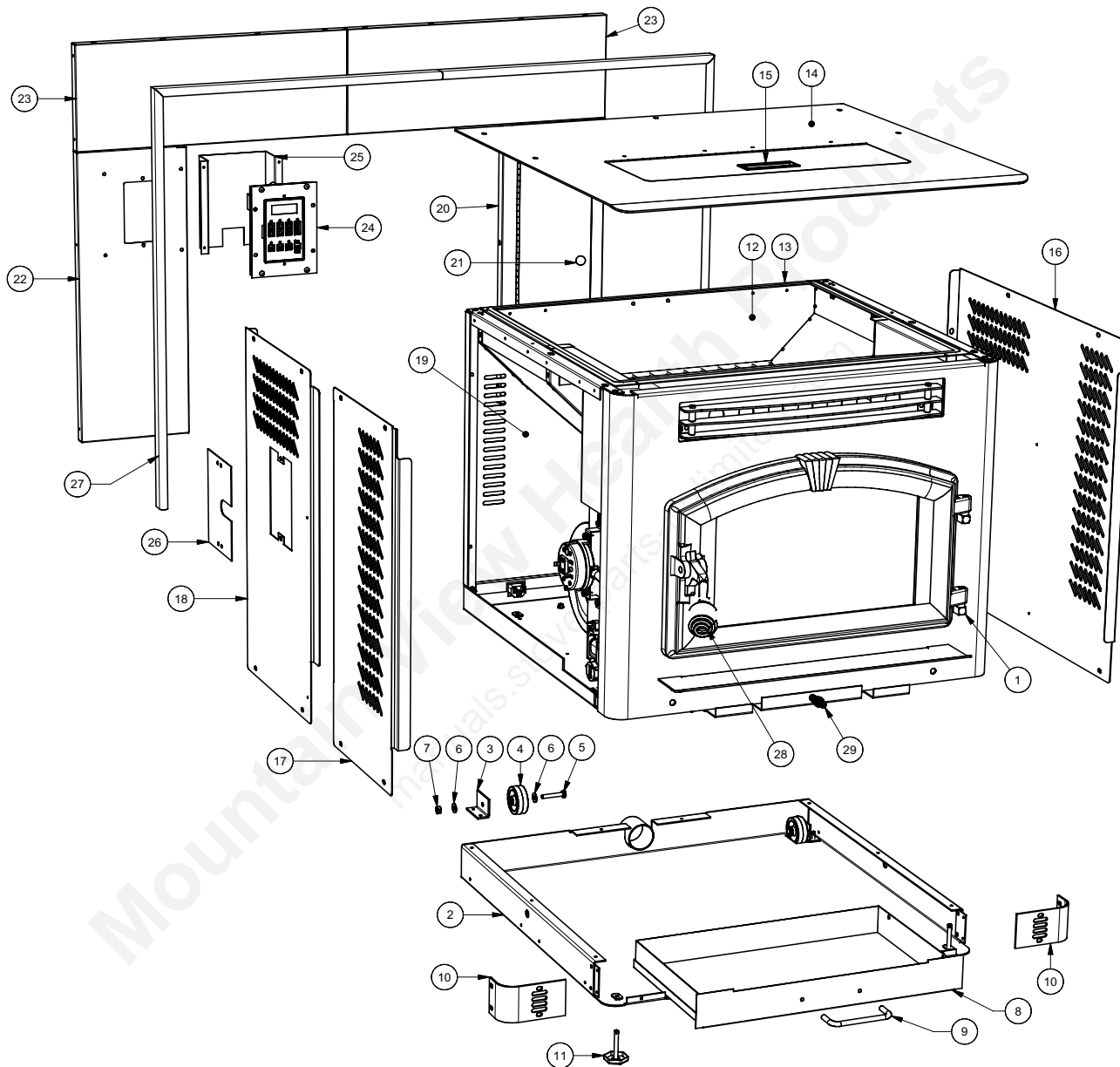

REPAIR PARTS LIST-6039I

FOR MODEL: 6039I	KEY	PART #	DESCRIPTION	QTY.
	1	891373	Pad, Door Hinge(Threaded)	2
	2	69547MB	Weldment, Sub-Base	1
	3	25569	Bracket, Caster	2
	4	891424	Caster, Plastic	2
	5	83412	1/4-20 x 1-1/2 Hex Bolt	2
	6	83136	Washer	4
	7	83261	1/4-20 Lock Nut	2
	8	69548MB	Weldment, Ash Pan	1
	9	891137	Handle, Brushed Nickel	1
	10	25570MB	Facade, Bottom	2
	11	83479	Leveler	2
	12	69549	Hopper Assembly	1
	13	88115	Gasket, Hopper Lid	8 ft
	14	25586MB	Weldment, Cabinet Top	1
	15	891148	Handle, Plastic	1
	16	25581MB	Right Side Cabinet	1
	17	25579MB	Left Side-Front Cabinet	1
	18	25580MB	Left Side-Rear Cabinet	1
	19	25578MB	Back, Cabinet	1
	20	25587MB	Weldment, Facade Panel-Right Side	1
	21	89943	Knob, Cabinet Door	1
	22	25585MB	Panel-Left Side, Facade	1
	23	25590MB	Top Panel, Facade (2 piece)	2
	24	80507	Circuit Board (6039)	1
	25	25583MB	Cover, PCB	1
	26	25582MB	Cover, Panel	1
	27	891435	Kit, Facade Trim (B-Lux)	1
	28	891135	Handle, Spring (Nickel)	1
	29	891331	Handle, Small Spring (Nickel)	1

Notice:

For all other repair components not listed above, refer to the 6039 Repair list and diagrams for info.

Parts Diagrams and Parts Lists

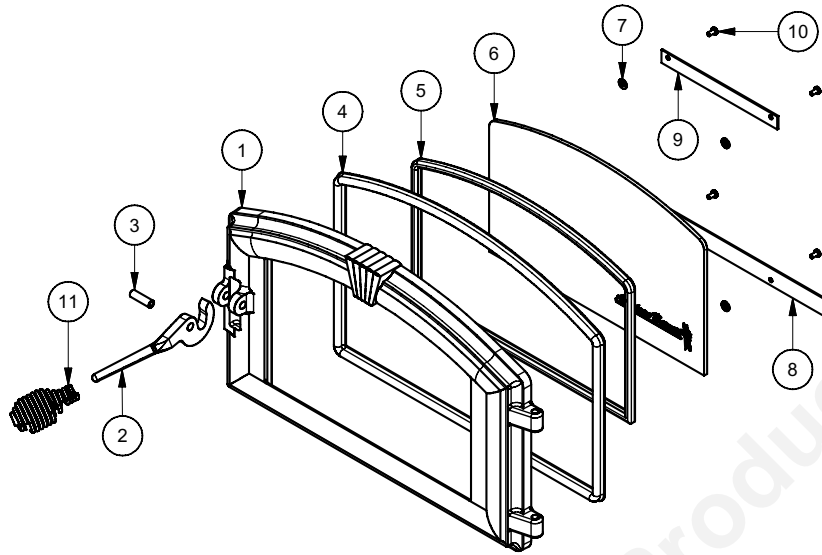

Parts List	Key	Part No.	Description	Qty.	Key	Part No.	Description	Qty.
	1	25491	Feed Door	1	7	83278	#10 Flat Washer	4
	2	25492	Handle, Door	1	8	25465	Retainer, Bottom Glass	1
	3	83506	Roll Pin, 3/8 x 1-1/4	1	9	25464	Retainer, Top Glass	1
	4	88112	Gasket, 1/2" Sq. Rope	5 ft	10	83202	Machine Screw	4
	5	88087	Gasket, Glass (1 x 3/16)	4 ft	11	89574	Handle, Spring (Parts Bag)	1
6	891131	Glass Ceramic	1					

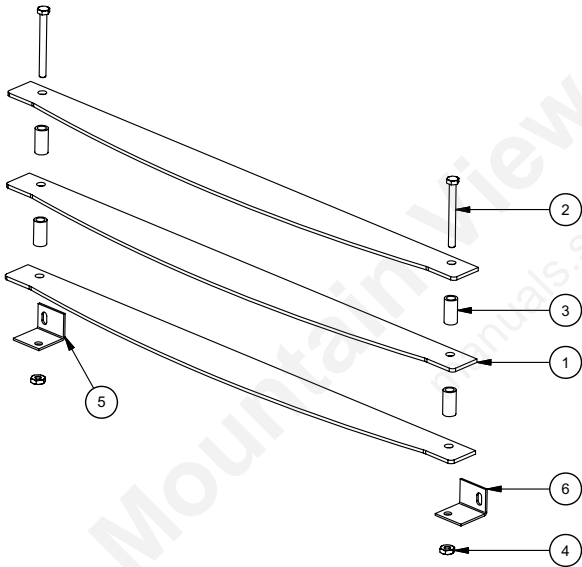

Louver Assembly (Part No.: 69497MB)

Parts List	Key	Part No.	Description	Qty.
	1	86623	Louver	3
	2	83531	Screw, 10-24UNC x 2" long	2
	3	83532	Spacer	4
	4	83295	Nut, 10-24UNC	2
	5	25444	Bracket, Louver (Left)	1
6	25445	Bracket, Louver (Right)	1	

6039T Parts Diagram & List

NOTE:

For internal parts, cabinet parts, etc. see pages 21-22

Parts List	Key	Part No.	Description	Qty.
	1	25523	Leg, Cast Iron	4
	1a	891216	Leg, Steel (alternate to item 1)	-
	2	25425	Guide Rail, Ash Pan	2
	3	69483B	Ash Pan Weldment	1
4	891138	Handle, Brass	1	

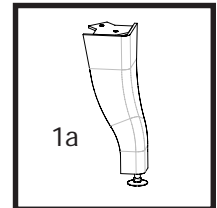
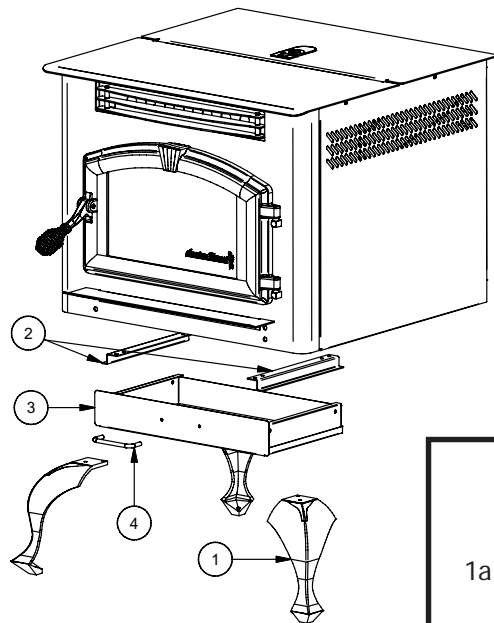

Mountain View Hearth Products
manuals.stove-parts-unlimited.com

HOW TO ORDER REPAIR PARTS

THIS MANUAL WILL HELP YOU OBTAIN EFFICIENT, DEPENDABLE SERVICE FROM YOUR AMERICAN HARVEST, AND ENABLE YOU TO ORDER REPAIR PARTS CORRECTLY.

KEEP THIS MANUAL IN A SAFE PLACE FOR FUTURE REFERENCE.

WHEN WRITING, ALWAYS GIVE THE FULL MODEL NUMBER WHICH IS ON THE NAMEPLATE ATTACHED TO THE HEATER.

WHEN ORDERING REPAIR PARTS, ALWAYS GIVE THE FOLLOWING INFORMATION AS SHOWN IN THIS LIST:

1. THE PART NUMBER
2. THE PART DESCRIPTION
3. THE MODEL NUMBER: 6039 6039I 6039T
4. THE SERIAL NUMBER: _____



United States Stove Company
227 Industrial Park Road
P.O. Box 151
South Pittsburg, TN 37380
(423) 837-2100
WWW.USSTOVE.COM