



Installation/Operator's Manual

Model(s) 6041, 6041TP, 6041HF, 6041I

READ THIS ENTIRE MANUAL, THOROUGHLY, BEFORE ATTEMPTING TO INSTALL AND/OR BURN YOUR NEW AMERICAN HARVEST *MULTI-FUEL HEATER. FAILURE TO FOLLOW THESE INSTRUCTIONS MAY RESULT IN PROPERTY DAMAGE, BODILY INJURIES OR EVEN DEATH.

Safety Notice: If this heater is not properly installed, a **house fire may result**. For your safety, follow the installation directions. Contact local building or fire officials about restrictions and installation requirements peculiar to your area. **Do Not Plug** this appliance into an electrical outlet before reading and understanding all operations and **always unplug** the unit before attempting any work or maintenance. Do not connect this heater to any chimney flue already serving another appliance. Carefully observe and maintain all **clearances to combustibles**.

A note about fuel: Use only **dried shelled corn** with a moisture content of 14% or less (**11 to 12% provides the best results**); any pellet fuel used should have an ash content of 1% or less. If not, efficiency will suffer. This heater has successfully burned pellets with a 2-1/2% ash content, though less ash is preferred and more efficient.

Your American Harvest Multi-Fuel Heater operates on a negative pressure. Therefore, **all venting connections (elbows, T-pipe) must be sealed and airtight.**

① Use Hi-Temp silicone at each joint or connection.

***This heater is capable of burning wood, biomass pellets and a wide variety of grains, including corn, soybeans, cherry and olive pits, and all larger seeds.**

SAVE THESE INSTRUCTIONS

UNITED STATES STOVE COMPANY GRANTS NO WARRANTY, IMPLIED OR STATED, FOR THE INSTALLATION OR MAINTENANCE OF THE HEATER AND ASSUMES NO RESPONSIBILITY FOR ANY CONSEQUENTIAL DAMAGE(S).

Tested &
Listed By



Portland
Oregon USA

Omni-Test Laboratories, Inc.

Safety Tested to ASTM-E 1509, (UM) 84-HUD

United States Stove Company • 227 Industrial Park Road, P.O. Box 151 • South Pittsburg, TN 37380 • www.usstove.com

CONGRATULATIONS!

You've purchased one of America's Finest Multi-fuel Burning Heaters. By heating with fuels such as corn and pellets, you're helping CONSERVE AMERICA'S ENERGY!

NOTE: YOUR UNIT MUST BE INSTALLED BY A QUALIFIED INSTALLER, such as an NFI (National Fireplace Institute) Certified Specialist

We strongly suggest installing smoke detectors in your home if not already installed.
Initial burn off may cause slight smoke and odor the first few hours of operation.
Perform initial burn outside if possible

SPECIFICATIONS

United States Stove Company reserves the right to alter products, specifications and price without notice.

Safety Tested & Listed to ASTM- E 1509, (UM) 84-HUD, by OMNI Test Laboratories, Inc., Portland, Oregon USA

Heat Input (as tested)	45,000 BTU/HR	
Heat Output (as tested) ☆	35,100 BTU/HR	
Heating Capacity	1,000-2,000 Sq. Ft ★	
Fuel Storage Capacity	60 Lbs.	
Width	29 in./737mm	
Height	6041TP/6041HF 31 in./787mm	6041I 24 in./610mm
Depth	28 in./711mm	

☆ BTU output will vary, depending on the brand, type and quality of fuel and the moisture content. Consult your dealer for best results.

★ Based on post 1982 home construction, requiring 35 BTU/Hr per Sq. Ft.

Remember, this heater should not be used as the only source of heat in the house. Power outages and neglect of periodic maintenance will result in a total loss of heat.

6041TP PEDESTAL TRIM ASSEMBLY

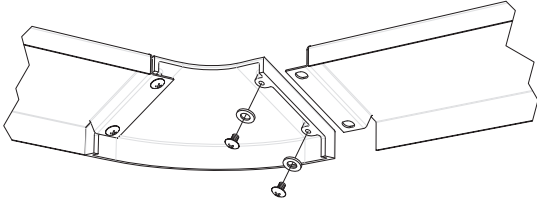

Assemble trim pieces as shown with the screws provided in the parts bag.

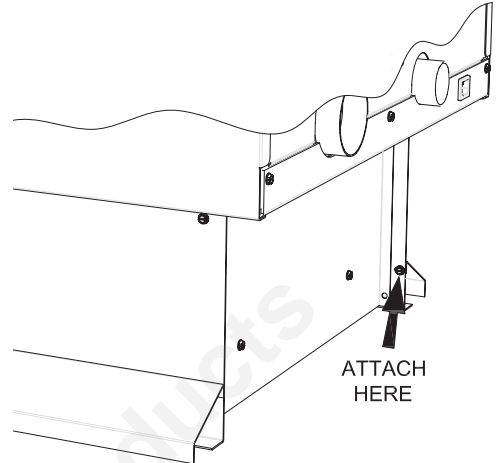
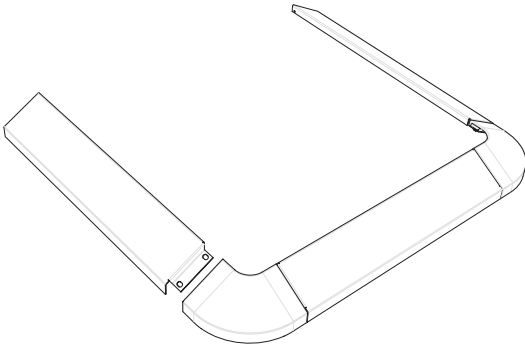

After trim assembly, attach to the pedestal base at the location shown using the screws provided.

6041HF ASSEMBLY

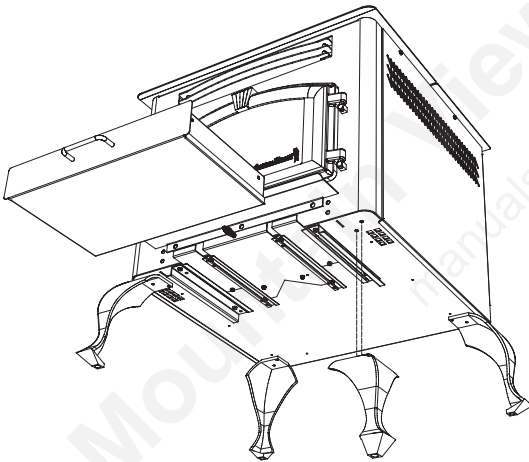

Assembly

- 1.** Unpack unit and make sure all components are included; (4) Legs, and all hardware for installation.
- 2.** Fold the corner padding from the carton and lay it on the floor behind the unit. This is used to hold the heater up off the floor to install the legs. Gently tilt the heater on its back, door opening up.
- 3.** Assemble the legs as shown using the eight(8) 1/4-20 bolts supplied.
- 4.** After all bolts and screws have been tightened properly, carefully set the heater back up on the legs.

6041I ASSEMBLY

DISCONNECT THE POWER CORD BEFORE SERVICING THIS Heater

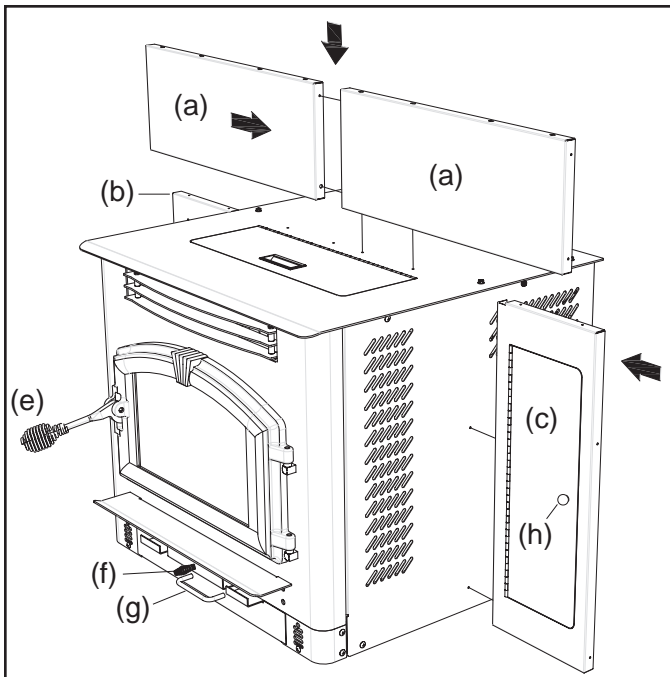

For the following assemblies, we suggest locating the unit near it's desired location. Depending on installation, you may want to connect the exhaust venting before installing the facade parts.

Assembly - Facade (Surround)

Remove contents from packaging and make sure you have all components:

- (2) Top Facade (a)
- (1) Left Side Facade (b)
- (1) Right Side Facade (c)
- (4 pieces) Facade Trim Kit (d)
- (1) Feed Door Spring Handle (e)
- (1) Damper Spring Handle (f)
- (1) Ash Pan "U" shaped Handle (g)
- (1) Access Door Knob (h)
- (1) PCB Cover (i)
- (1) Panel Cover (j)
- (1) Auger (in ash pan)
- (1) Power Cord
- (1) Burnpot Poker (k)
- Mounting Hardware

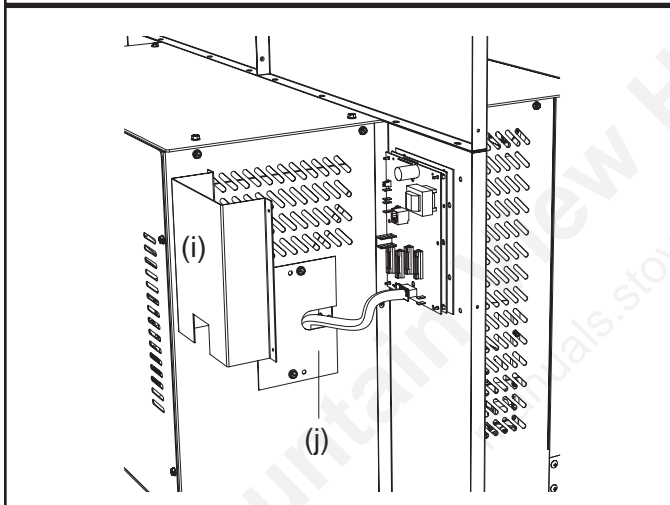

Start by mounting either the left or right side facade pieces to the unit using four(4) of the supplied #10 x 1/2 screws. Then put the two(2) top facade pieces together with two(2) of the #10 x 1/2 screws provided. Attach the top facade assembly to the unit with eight(8) of the same screws.

Control Board (PCB) Re-location

Remove the left side front panel from the unit. While holding the PCB with one hand, remove the two(2) hex head screws holding the board in place. It is not necessary to unplug the PCB cable. Route the board and cable through the opening and mount it to the Left Facade using two of the #10 x 1/2 phillips head screws provided. Then attach the PCB cover to the back of the facade covering the board. Next, use the two hex head screws removed earlier and mount the cover panel over the opening where the PCB was located. See illustration to the left.

Facade Trim

Remove trim from shipping tube. There should be one(1) left side, one(1) right side, two(2) top pieces, and mounting hardware. Using one blank corner key and one corner key with set screws, assemble the left trim and one of the top pieces together. As illustrated, place the blank key behind the key with the set screws. Adjust corners and tighten set screws. Repeat this for the right side

Before removing tape, place trim assembly against facade to get an idea of how it is to be mounted. Remove the strip from the adhesive and carefully secure the trim in place by firmly pressing it to the facade.

Burnpot Poker

The burnpot poker may be used several ways. It is used primarily as a fuel-loading assistant to help push the fuel to the rear of the hopper for maximum fueling. It may also be used for cleaning of ashes or removal of clinkers.

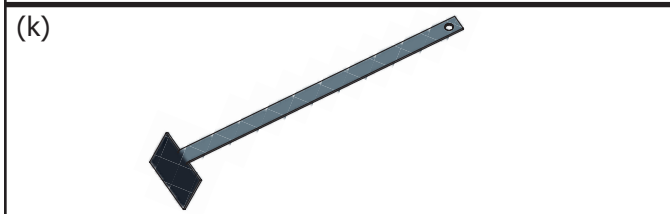
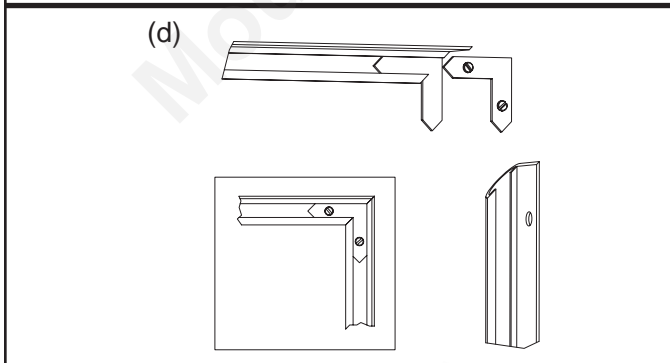

COMPONENT LOCATION

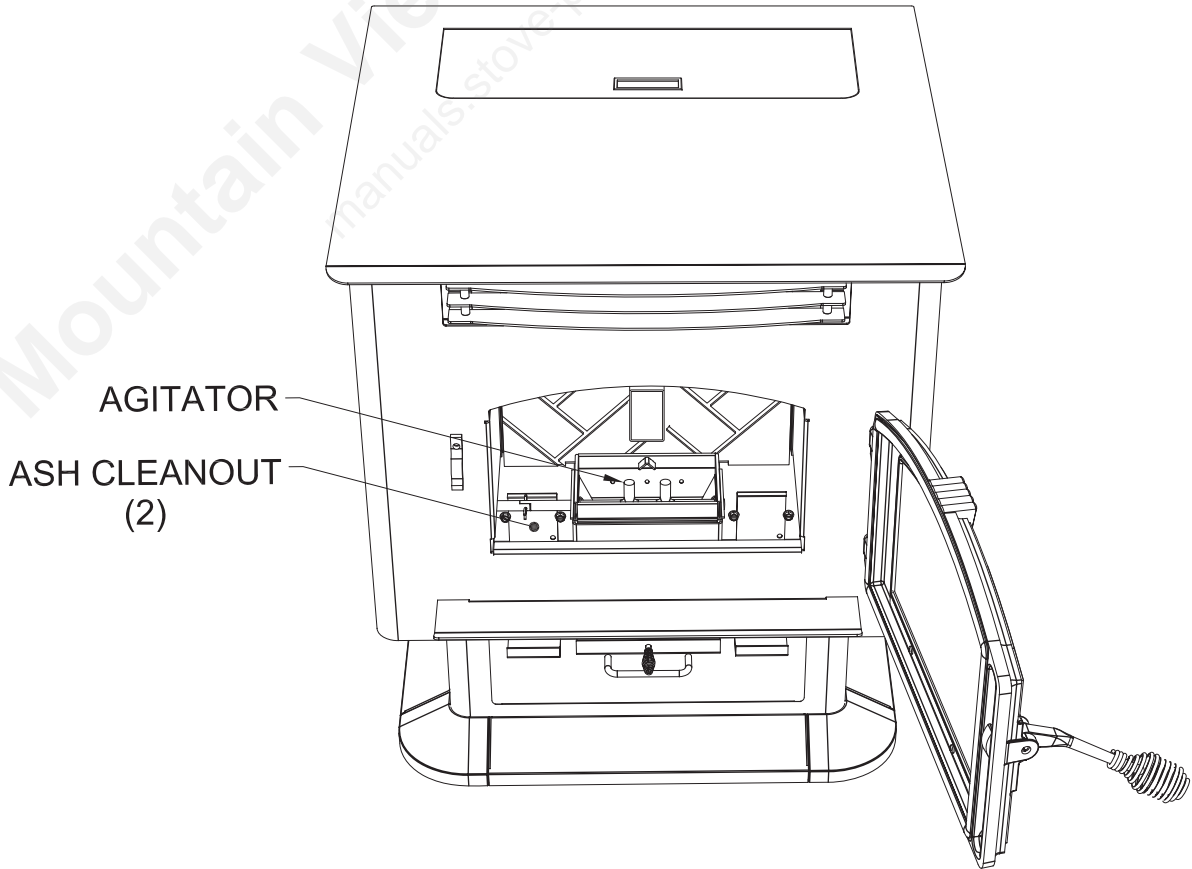
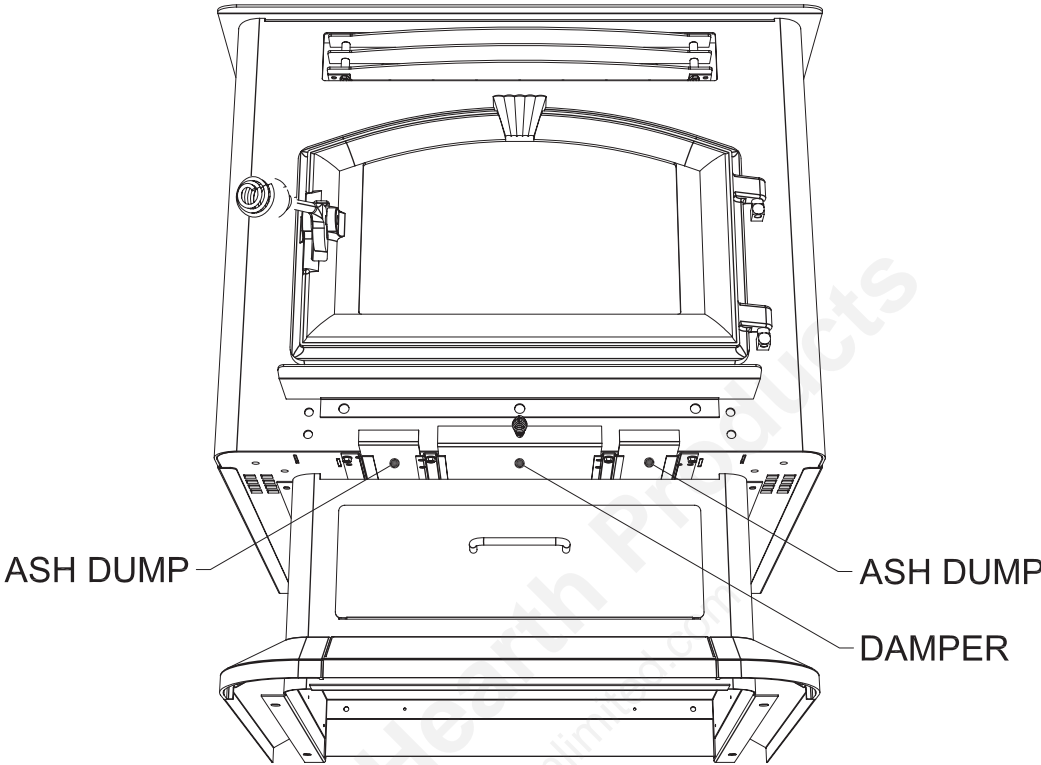

SAFETY STEPS

IMPORTANT: Proper installation of this heater is necessary for safe and efficient operation. Installing this product improperly may result in a house fire and personal injury. All applicable building codes for your location must be followed. In areas where building codes require additional steps to the installation of this product not included in this manual, the building codes will take precedent and must be followed. Contact your local building inspector to obtain any necessary permits or inspection guidelines before installing the product.

- The **American Harvest** heater is designed to burn dry shelled corn, cherry pits, or pelletized fuel such as wood and biomass pellets. The burning of other solid fuels such as cord wood or wood chips in this heater is not permitted.
- This product requires simple periodic maintenance for proper operation and long life of the heater. Read and follow the maintenance schedule closely.
- **DISCONNECT THE POWER CORD BEFORE SERVICING THIS HEATER!**
- **A power surge protector is required.** The unit must be plugged into a **grounded** 110-volt power source. Circuit Boards are very expensive - protect yours!
- Always route the power cord away from the unit. Do not route cord in foot traffic areas. Do not pinch cord under furniture. Do not route the cord across the exhaust pipe.
- A working smoke detector must be installed in the same room as this product.
- Flammable or explosive liquids such as gasoline, naphtha, alcohol, lighter fluid, or engine oil must **NEVER** be used in or around this heater. These liquids must be stored well away from this heater as the open flame in the burner chamber could ignite the fumes of such liquids. Do not burn garbage in this unit.
- The moving parts of this heater are propelled by high torque electric motors. The Auger and Fuel Agitator can cause severe injury to body parts that may get near them. Keep all body parts away from the Auger and Fuel Agitator while the heater is plugged into an electrical outlet. These moving parts may begin to move at any time while the heater is plugged in.
- According to HUD requirements, when installed in a mobile home, this heater must be grounded directly to the steel chassis of the mobile home and bolted to the floor. Direct air access must be provided - Use 69FAK Fresh Air Kit
- This heater is not intended for use in commercial installations.
- Do not connect this heater to "B" vent. **Use UL Listed Pell Vent ONLY!**
- Do not elevate the fire by use of grate or any other means other than the supplied burnpot.

BURNING SOLID FUELS

Ashes will have to be removed from the heater for proper operation. See cleaning procedure.

Your Multi-fuel heater, due to the nature of solid fuels, will require brief periodic attention. Please do not expect to light your heater and walk away from it. A few moments of adjustment and cleaning is an important part of burning solid fuels, due to the vast differences in fuel, humidity and outside temperature.

The Multi-fuel heater has been designed to burn dry shelled corn, wood pellets and other pelletized fuels that meet Association of Pellet Fuel Industries standards.

BURNING SOLID FUELS continued...

SHELLED CORN (Dry, preferably corn with 11- 12% moisture content)

- **Corn must contain less than 14% moisture content.** Wet corn will rapidly deteriorate heater components, reduce efficiency and void all warranties. Purchase a moisture tester if in doubt.
- Corn must be clean and free from debris. Never burn corn right from the field. Damage caused by dirty corn is not covered by the product warranty. Ask for clean **filtered** bagged corn only. Stalk parts, excessive fines and cob remnants will clog the auger. Check your corn for foreign objects.
- **NEVER BURN SEED CORN IN YOUR Heater.** Seed corn is treated with chemical pesticides that are harmful or fatal if swallowed, therefore, seed corn is dangerous to have in the house, especially where children can reach it.
- Never burn "Deer Corn." It frequently contains molasses, sugars and salts.
- Store your corn supply in a dry place and keep bags or container sealed to prevent your corn from absorbing excess moisture. Test the moisture content periodically to ensure the proper dryness.
- There are many varieties of corn grown around the world. Each variety has unique characteristics including the shape and size of the kernel. Your heater will burn more consistently with a small to midsize kernel corn. If the kernel size of the corn varies greatly or if you switch sources frequently, you will get a less consistent burn. Therefore, purchasing corn from the same source will help achieve a more consistent burn. **DO NOT USE CORN WITH A HIGH WAX CONTENT!**

WOOD and BIOMASS PELLETS

- As with corn, be consistent in your pellet supplier. Pellets will vary in content and burn characteristics from supplier to supplier. A consistent supply of pellets will result in a more consistent and efficient burn.
- Check your pellets for foreign objects. Your heater warranty will not cover damage done to your heater due to foreign objects in the fuel supply.
- **Store your pellets in a dry place to prevent them from absorbing added moisture.**
- To decrease sawdust buildup, the hopper and auger tube will need to be vacuumed out after every 6-8 bags of pellets or more often if the pellets are poor quality. The hopper should be empty of fuel when this is performed. You may have to screen each bag of pellets if sawdust becomes a problem.
- Wood Pellets vary in size and ash content from less than 1% to 3% or more. Your heater will burn more efficiently with small to midsize pellets (Preferred pellet size is 1/4" diameter x 1" length). Low ash content pellets will allow you to burn the heater longer between cleanings. Only wood pellets manufactured to the Pellet Fuel Institute (P.F.I) standard for residential pellets fuels are recommended. Performance will suffer if nonstandard pellets are used. Consult your local **American Harvest** dealer for more information on approved wood pellet fuel.

CAUTION:

DO NOT PLACE SUCH FUELS WITHIN THE SPACE HEATER'S INSTALLATION CLEARANCES OR WITHIN THE SPACE REQUIRED FOR FUELING AND ASH REMOVAL.

INSTALLATION REQUIREMENTS

FLOOR PROTECTION

The Multifuel Heater may be installed on a combustible floor, **with proper floor protection**, or on a masonry hearth. The hearth or noncombustible floor protector must extend a minimum of (6) inches (152mm) in front and (6) inches (152mm) from each side of the unit.

CLEARANCES TO COMBUSTIBLES 6041(TP)(HF)

The heater must be installed with the following minimum clearances to side and back wall combustible materials.

NOTE: These are minimum clearances to combustible walls established by the testing lab.

PARALLEL - A - Sidewall to Top Edge of Unit	8 in./203mm
B - Sidewall to Flue	13 in./330mm
C - Backwall to Flue	3 in./75mm
D - Backwall to Unit	9 in./228mm
CORNER - E - Adjacent Wall to Flue	3 in./75mm
F - Adjacent Wall to Unit	4 in./100mm

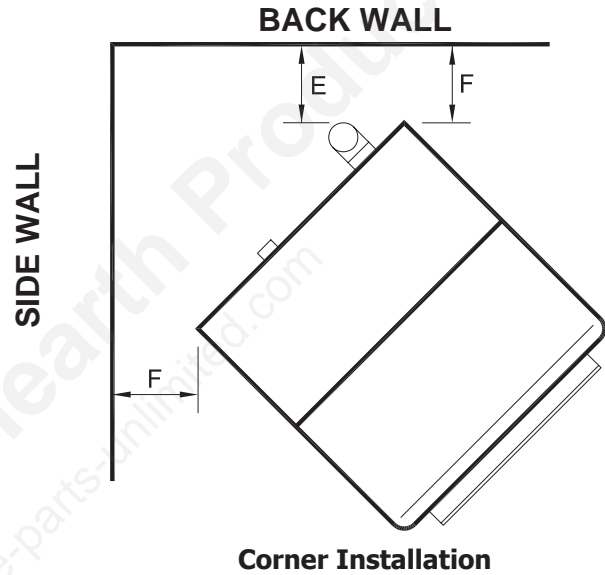
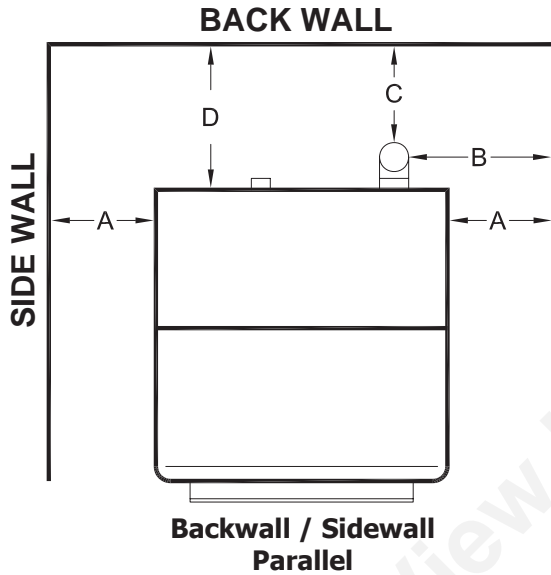

NOTE:
Allow sufficient space to remove the left and right side panels for maintenance purposes.

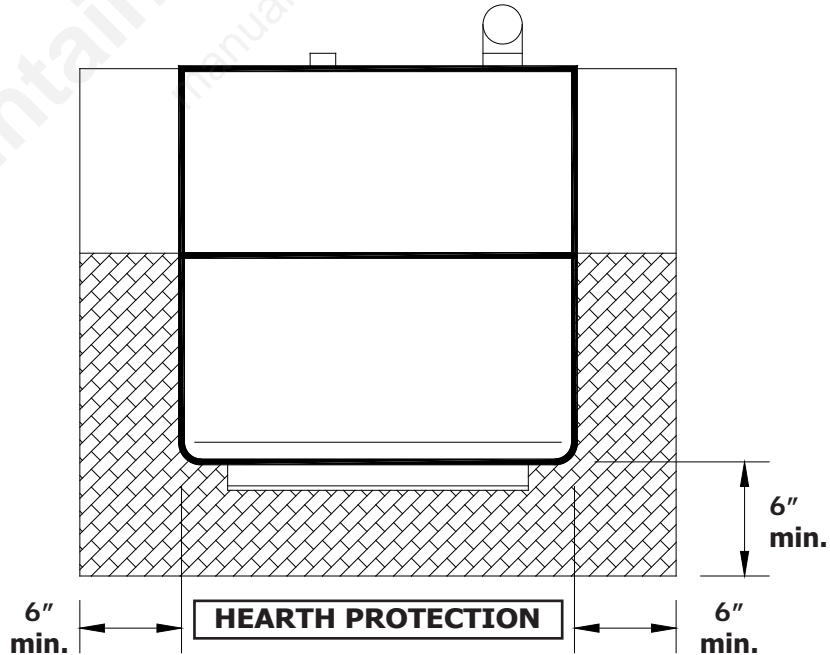

These clearances must be maintained.

CLEARANCES TO COMBUSTIBLES 6041I

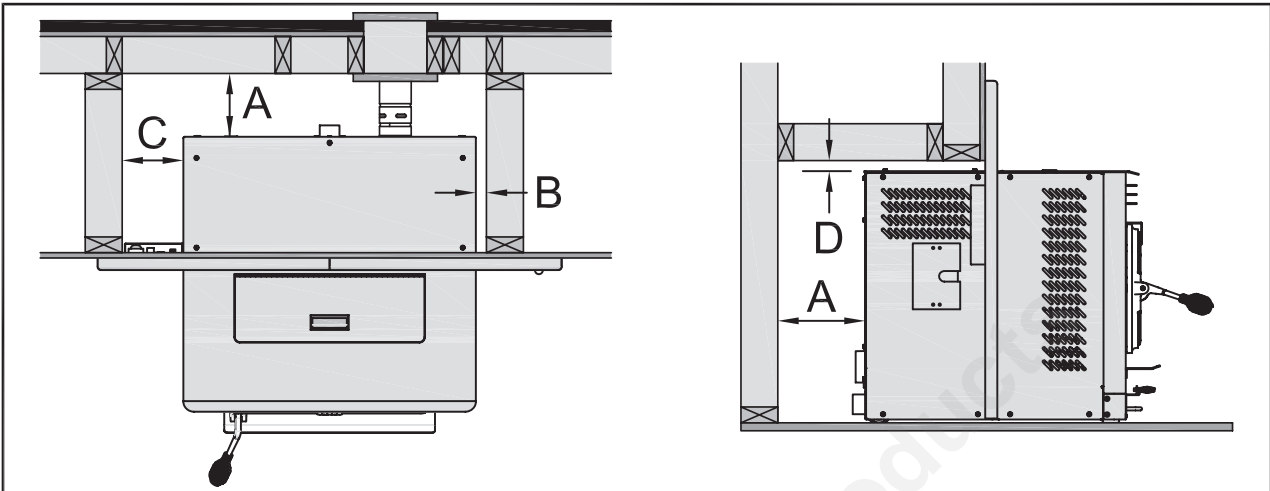

AS A BUILT-IN

KEY		INCHES
A	BACK OF UNIT TO WALL	6
B	RIGHT SIDE OF UNIT TO WALL	1
C	LEFT SIDE OF UNIT TO WALL	6
D	TOP OF UNIT TO WALL	1

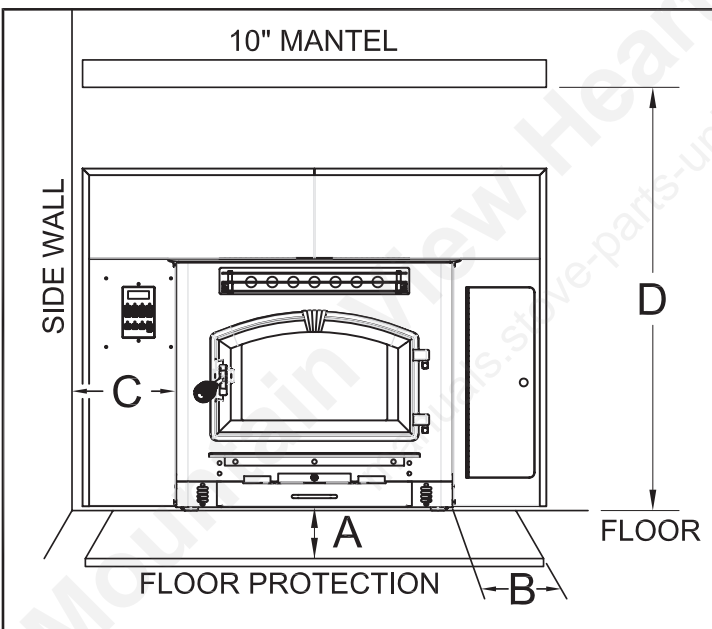

EXTERNAL CLEARANCE TO COMBUSTIBLES		
KEY		INCHES
A	FLOOR PROTECTOR EDGE TO FRONT OF UNIT	6
B	FLOOR PROTECTOR EDGE TO SIDE OF UNIT	6
C	LEFT SIDE OF UNIT TO WALL	8
D	FLOOR TO MANTEL	53

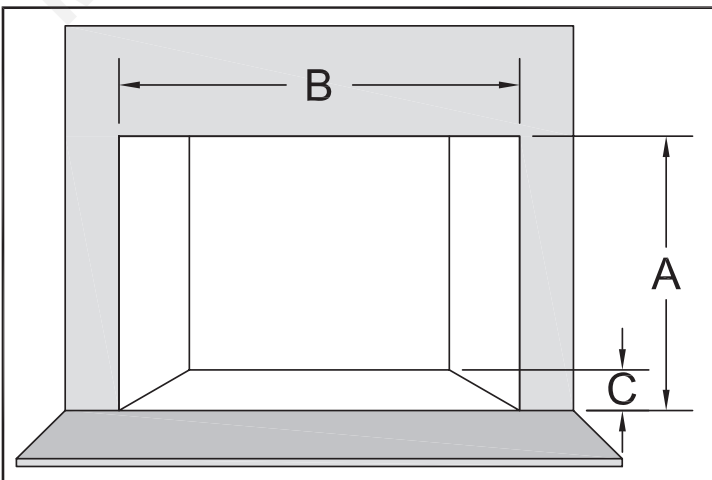

MINIMUM OPENING FOR MASONRY AND FACTORY-BUILT FIREPLACES		
KEY		INCHES
A	HEIGHT	24
B	WIDTH	40
C	DEPTH	20

GUIDELINES FOR EXHAUST VENTING SYSTEMS DESIGN

It is recommended that only an authorized installer install your multi-fuel heater, preferably an NFI certified specialist. The following installation guidelines must be followed to ensure conformity with both the safety listing of this heater and to local building codes.

INSTALL VENT AT CLEARANCES SPECIFIED BY THE VENT MANUFACTURER.

- A UL listed 3" or 4" type "PL" pellet vent exhaust system must be used for installation and attached to the pipe connector provided on the back of the heater. Use a 3" to 4" adapter for 4" pipe. A cap must be used at the termination of type "L" vent chimneys. 4" PL is required for elevations above 2,500 feet above sea level.
- Do not terminate vent in any enclosed or semi-enclosed area, such as; carports, garage, attic, crawl space, under a sundeck or porch, narrow walkway or close area, or any location that can build up a concentration of fumes such as a stairwell, covered breezeway etc.
- Vent surfaces can get hot enough to cause burns if touched by children. Noncombustible shielding or guards may be required.
- **Do not install a flue damper in the exhaust vent of this unit.**
- Termination must exhaust above air inlet elevation. Installation MUST include three (3) vertical feet of pellet vent pipe. This will create some natural draft to prevent the possibility of smoke or odor during appliance shutdown and to keep exhaust from causing a nuisance or hazard from exposing people or shrubs to high temperatures. **Do not connect this unit to a chimney flue serving another appliance. Do not connect directly to a masonry chimney.**
- The installation must include a cleanout tee to enable collection of fly ash and to permit periodic cleaning of the exhaust system. 90° elbows accumulate fly ash and soot thereby reducing exhaust flow and performance of the heater. Each elbow or tee reduces draft potential by 30% to 50%. Use no more than 180 degrees of elbows (two 90-degree elbows, or two 45-degree and one 90-degree elbow, etc.) and one cleanout tee to maintain adequate draft. Cleanout tees and elbows should not be connected to the rear of the unit unless a 3-inch adapter is used.
- Total length of horizontal vent must not exceed 48"(4ft.)/1,200mm. The maximum recommended vertical venting height is 12-feet for 3-inch type "PL" vent. For venting higher than 12-feet, 4-inch "PL" vent must be used. All joints in the vent system must be fastened by at least 3 screws, and all joints must be sealed with RTV silicone sealer to be airtight.
- The area where the vent pipe penetrates to the exterior of the home must be sealed with silicone or other means to maintain the vapor barrier between the exterior and the interior of the home.

NOTE: These are guidelines only. Proper venting is accomplished by design and necessary requirements. In most installations 3 inch diameter venting is adequate. If it does not vent properly you will have to change it to 4 inches. You should not exceed 4 inch diameter venting.

DO NOT CONNECT TO ANY AIR DISTRIBUTION DUCT OR SYSTEM

VENT TERMINATION CLEARANCES:

- A)** Min. 4-ft clearance below or beside any door or window that opens.
- B)** Min. 1-ft clearance above any door or window that opens.
- C)** Min. 3-ft clearance from any adjacent building.
- D)** Min. 7-ft clearance from any grade when adjacent to public walkways.
- E)** Min. 2-ft clearance above any grass, plants, or other combustible materials.
- F)** Min. 3-ft clearance from a forced air intake of any appliance.
- G)** Min. 2-ft clearance below eaves or overhang.
- H)** Min. 1-ft clearance horizontally from combustible wall.
- I)** Must be a minimum of 36-inches above the roof and 24-inches above the highest point or the roof within 10-feet.

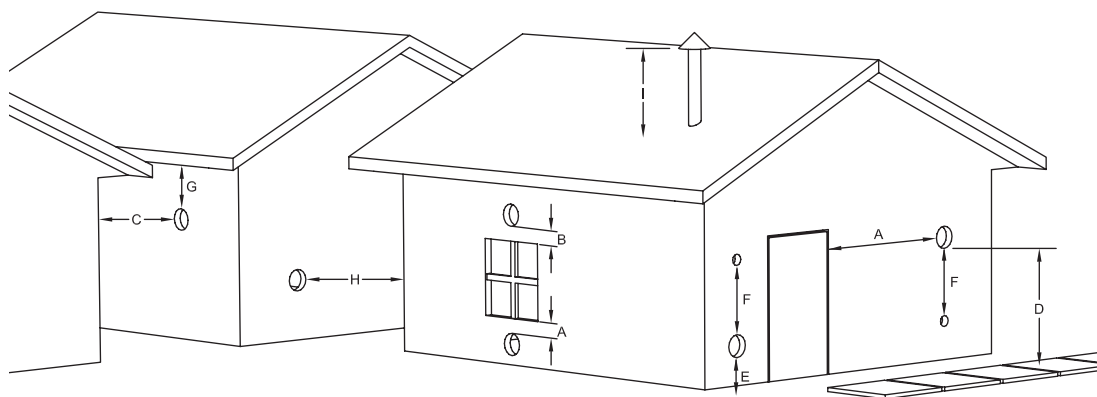

DESIGN GUIDELINES FOR OUTSIDE COMBUSTION AIR CONNECTION

1. For installations with horizontal through-the-wall exhaust, it is strongly recommended that the heater combustion air be connected to the outside. If the home is newer or has been tightly insulated, it is required to install outside combustion air.
2. Connection to outside the house is REQUIRED for mobile home installations. We strongly urge use of the 69FAK Fresh Air Kit.

90 DEGREE BEND TERMINATION

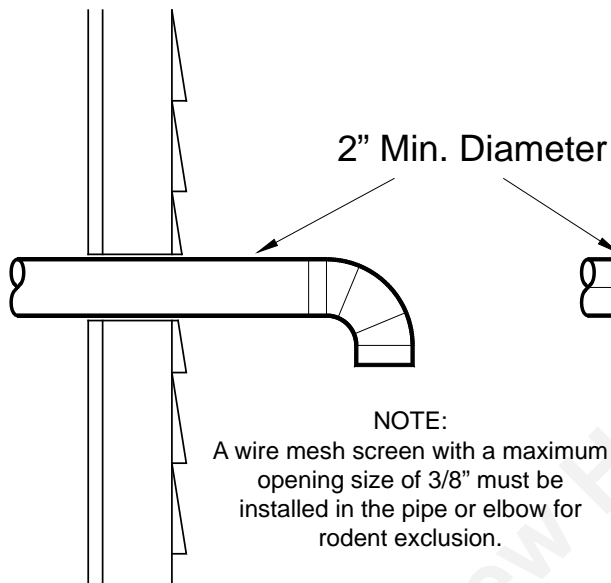

WIND HOOD TERMINATION

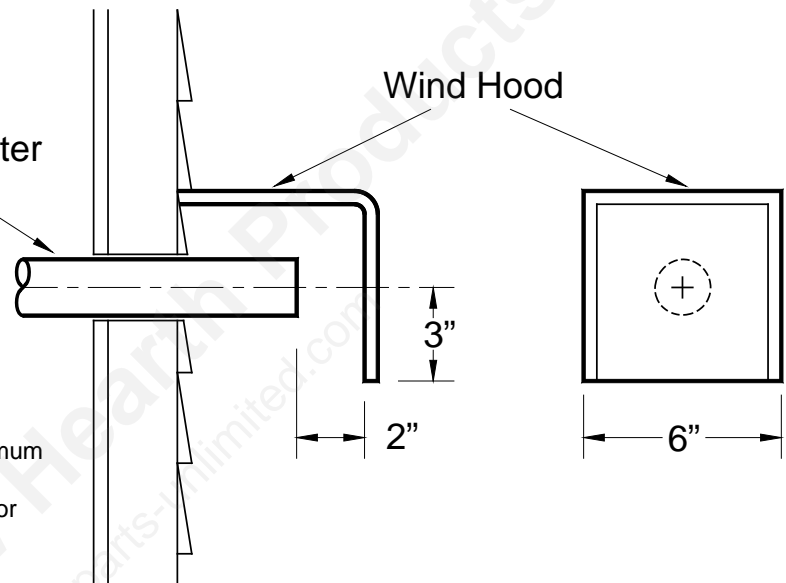

3. Only noncombustible pipe 2 inches (or greater) in diameter is approved to use for outside air connections (straight or flexible). PVC pipe is NOT approved and should NEVER be used.
4. If the air inlet is connected to the outside, it MUST be terminated with a vertical 90-degree bend (down) or with a wind hood. Failure to do so could result in a burn back during high winds blowing directly up the air inlet during a simultaneous power failure (see diagram above).
5. Blockage, excessive length, or extra bends in the air intake pipe will starve the heater of combustion air. A 90-degree bend is equivalent in restriction to approximately 30 inches of straight inlet pipe.

CAUTION: The operation of exhaust fans such as bath room fans, attic fans, etc. might starve the heater of combustible air creating a negative pressure in the room. Provide adequate ventilation in the room accompanying the heater. If not, the pressure switch may shut off operation of the heater. (Due to negative pressure)

INSTALLATION CONFIGURATIONS

The Multifuel Heater Model 6041TP/6041HF may be installed as follows:

- 1) A freestanding unit

The Multifuel Heater Model 6041I insert may be installed as follows:

- 1) In a pre-fab firebox (Factory Built)
- 2) In an existing masonry fireplace
- 3) As a build-in

MOBILE HOME INSTALLATION REQUIREMENTS

IN ADDITION TO THE STANDARD INSTALLATION INSTRUCTION, THE FOLLOWING REQUIREMENTS ARE MANDATORY FOR INSTALLATION IN A MOBILE HOME:

WARNING
DO NOT INSTALL IN SLEEPING ROOM

- 1) Heater must be permanently bolted to the floor. Remove the Base Trim and bolt thru the base flange.
- 2) Heater must have permanent outside air source. (69FAK)
- 3) Heater must be permanently electrically grounded to the steel chassis of the mobile home.
- 4) All vertical chimney vent must have wall supports.
- 5) All exhaust systems must have a spark arrestor.

CAUTION
**THE STRUCTURAL INTEGRITY OF THE MOBILE HOME FLOOR, WALL AND CEILING/
ROOF MUST BE MAINTAINED.**

Check with your local building official as other codes may apply.

Note: Always check dimensions on unit before cutting hole in wall

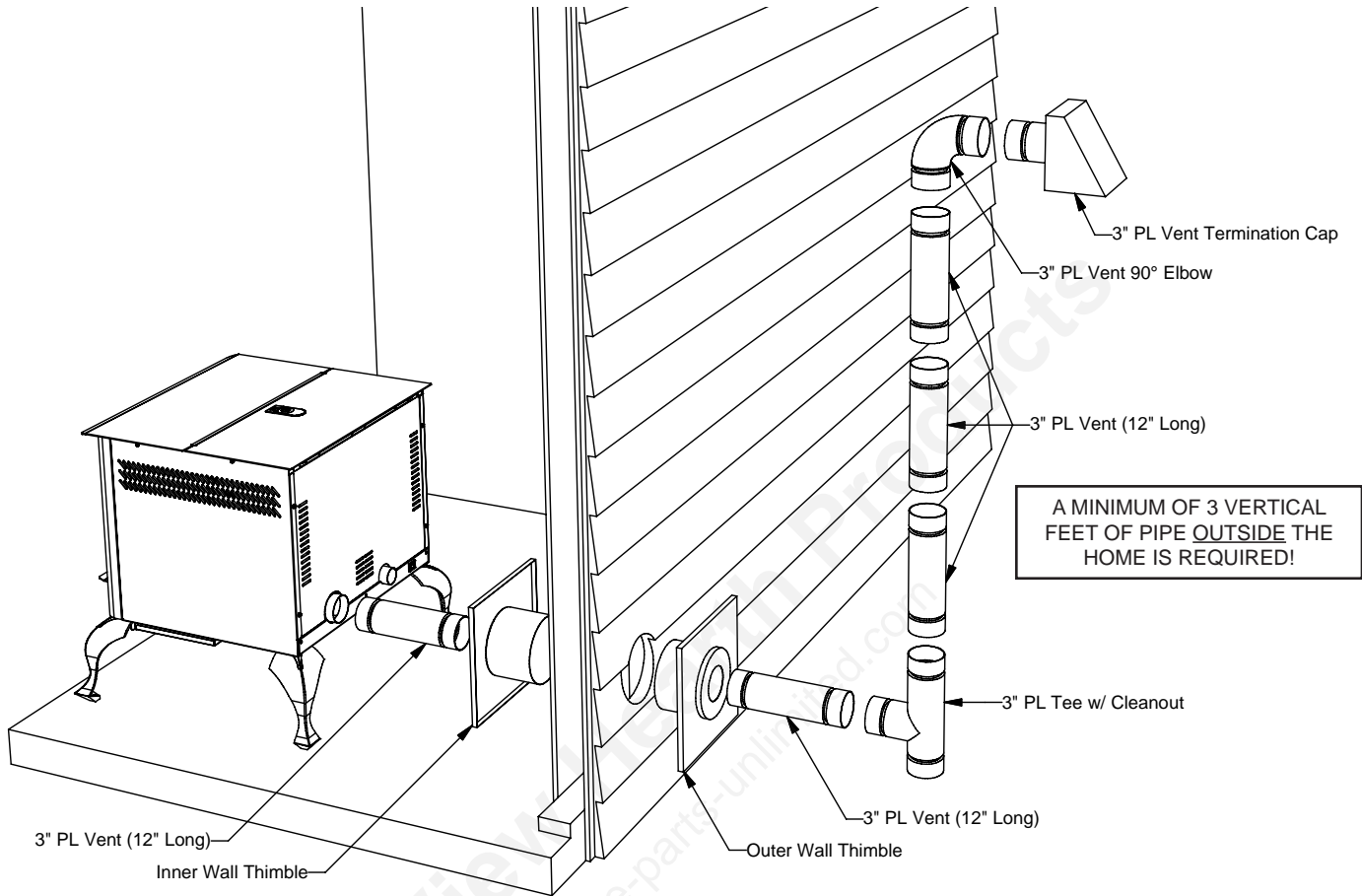

*For illustrations purposes only

6041TP - PEDESTAL UNIT

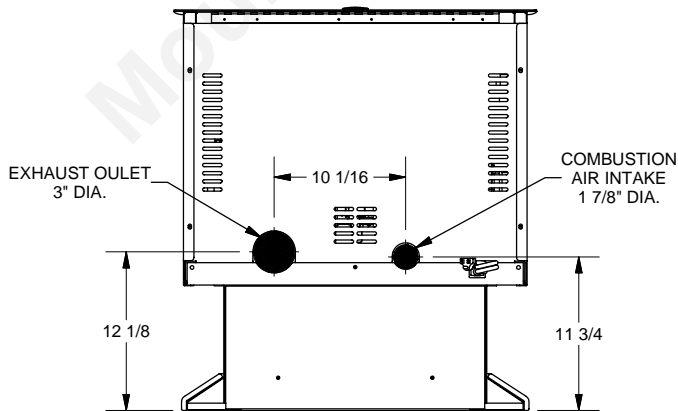

6041HF- LEG UNIT

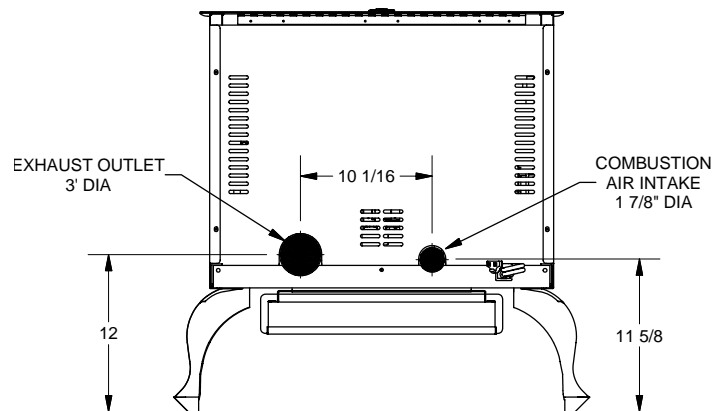

Dimensional tolerance
±1/4"

THROUGH THE WALL, VERTICAL PIPE INSTALLATION WITH TERMINATION CAP

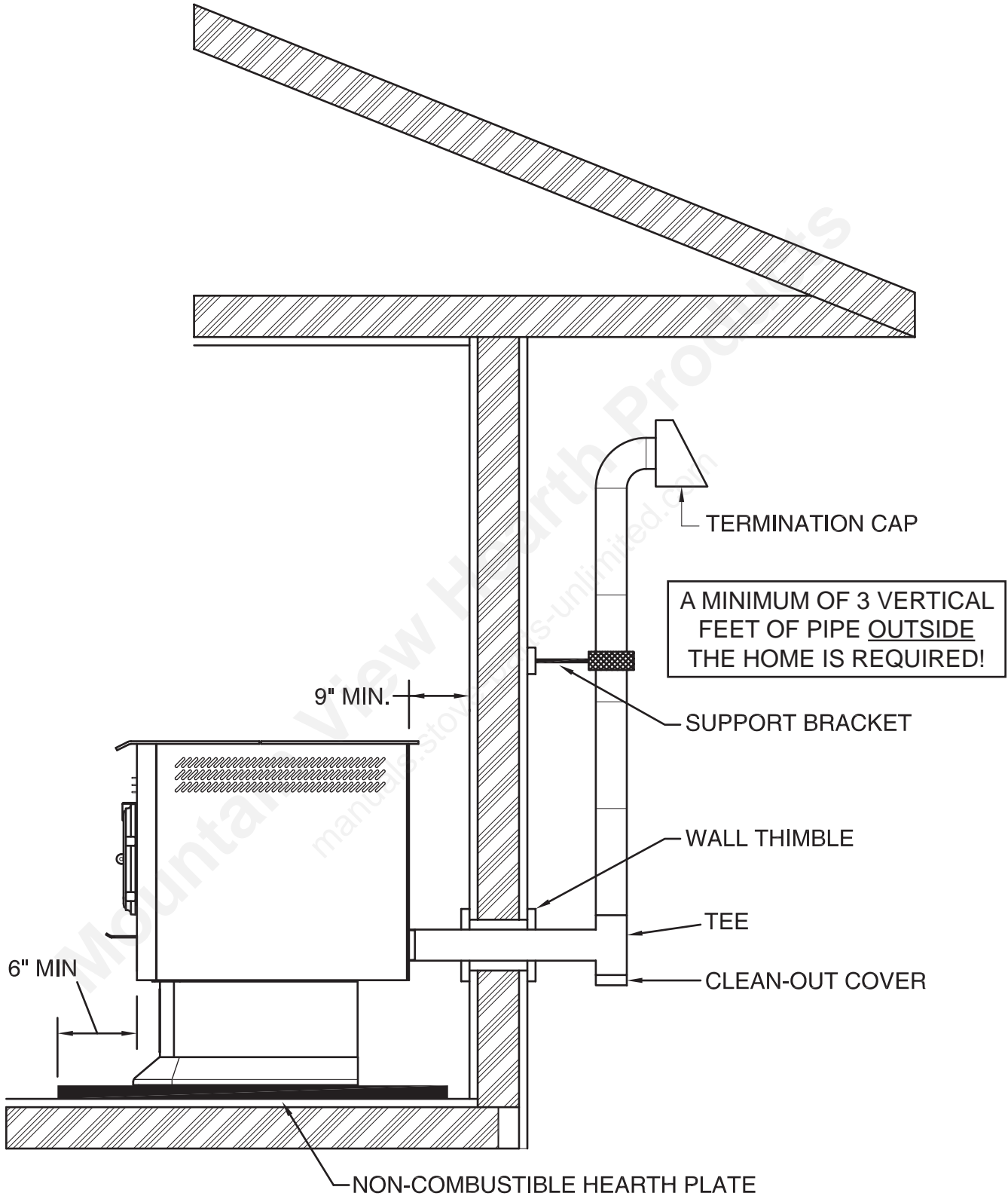

The Hearth Pad is not required under the unit if the floor is noncombustible but is required 6 inches (152mm) beyond the front of the unit and 6 inches (152mm) beyond each side of the door if the floor is a combustible floor. (wood flooring, carpet, linoleum, etc.)

DESIGN GUIDELINES FOR 6041I INSERT INSTALLATION

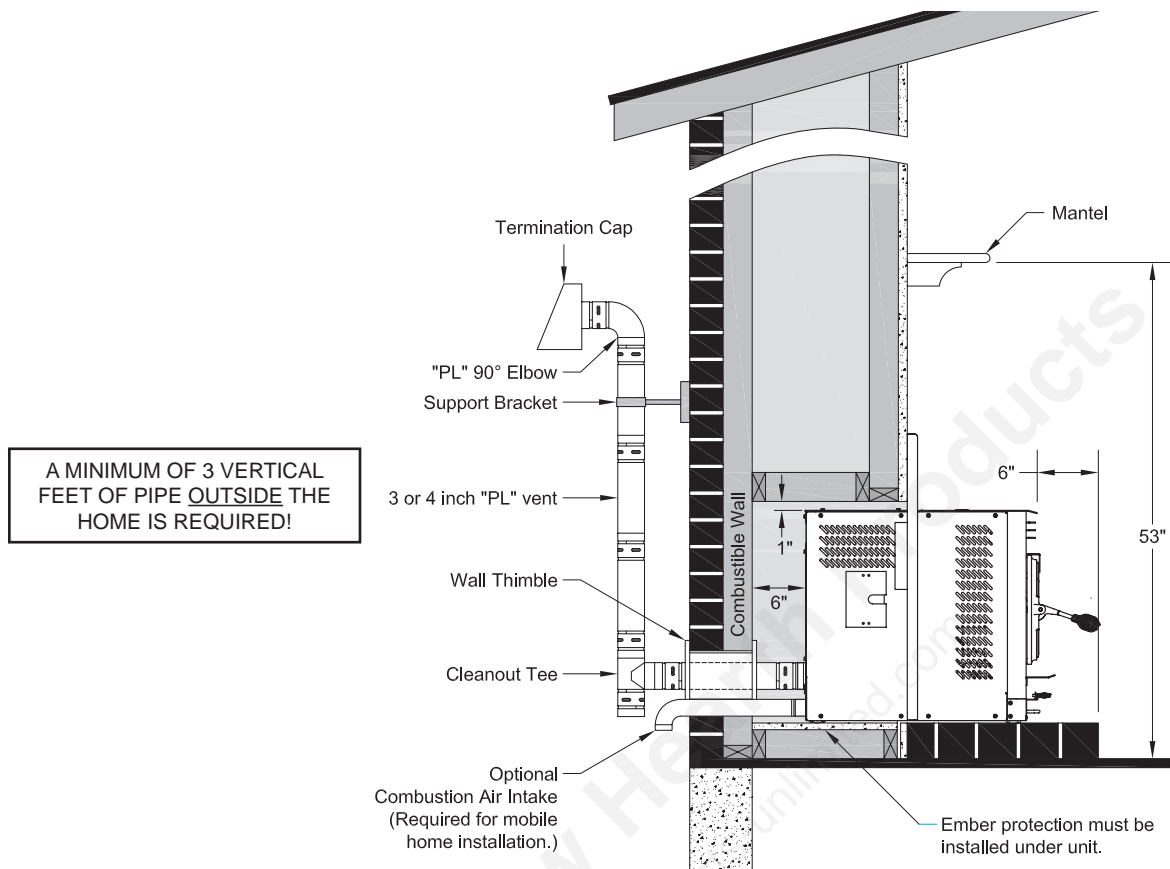

INSTALLATION AS A BUILT-IN FIREPLACE

A continuous sheet of non-combustible floor protection must be installed underneath the unit to prevent the possibility of embers falling through to the combustible floor. If the floor beneath the unit is of non-combustible material, the protector is not required.

See the "Clearance to Combustibles" section of this manual for installation clearances.

Alternative Exhaust Venting

Depending on your installation, you might consider routing your cleanout tee as illustrated below for ease of cleaning. The access panel in the right side facade allows you to reach the tee from the front side of the unit if venting is assembled as shown. The cleanout tee is attached to a 90° elbow mounted to the unit then rotated at approx. 15-20 degrees. A 12 inch section of "PL" vent is connected to reach the top of the unit to which a flexible pipe may be attached for further termination through a chimney. Clearance to combustibles must be considered if this installation is chosen. A distance of 3 inches must be maintained from the exhaust vent to any combustible material.

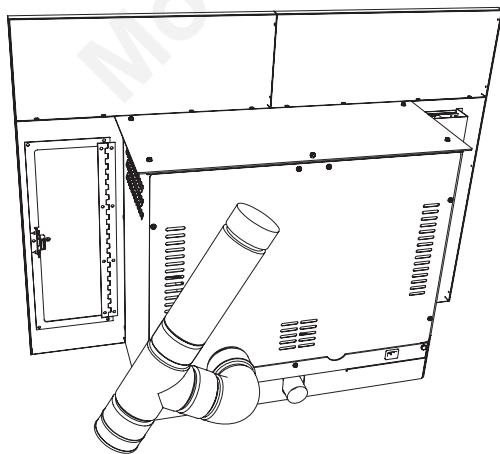

DESIGN GUIDELINES FOR 6041I INSERT INSTALLATION

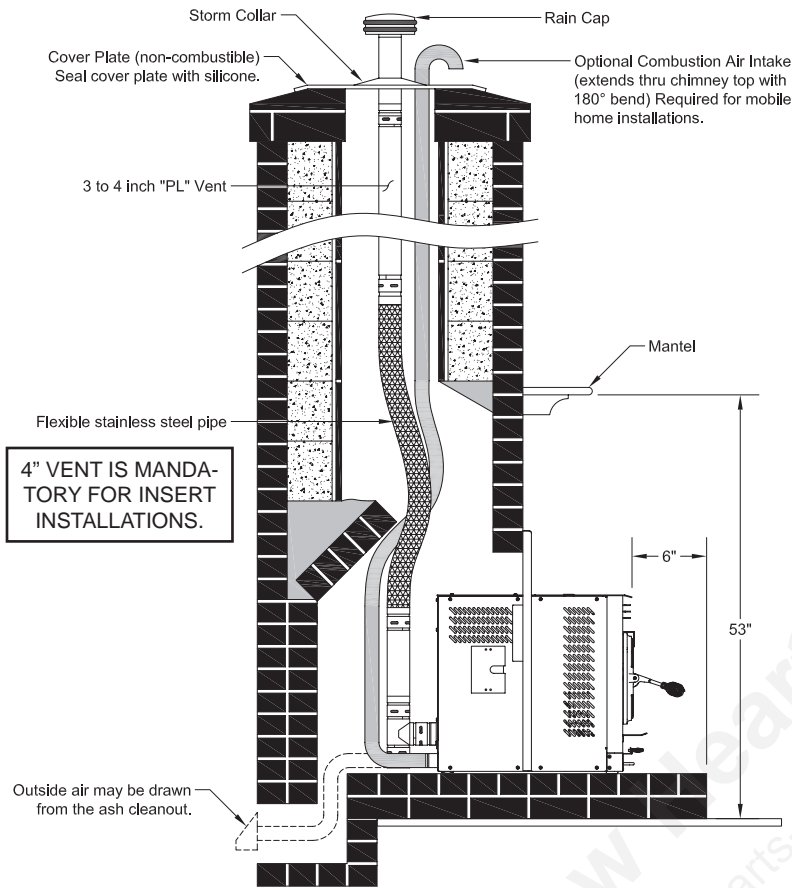

INSTALLATION INTO A MASONRY FIREPLACE

When installing into a masonry fireplace, **DO NOT** remove any bricks or masonry, with the following exception: masonry or steel, including the damper plate, may be removed from the smoke shelf and adjacent damper frame, if necessary, to accommodate a chimney liner. Do this only if their removal will not weaken the structure of the fireplace or the chimney, and will not reduce protection for combustibles to less than that required by national building codes.

Installation must include a chimney liner (4" Pell Vent "PL" Piping) that extends the full height of the chimney and meets type HT requirements. The liner must be securely attached to the insert and the chimney top. The chimney must be sealed either at the top or at the damper area with a non-combustible plate to prevent room air passage to chimney cavity.

Outside combustion air may be drawn through the chimney top or through an existing ash cleanout.

INSTALLATION INTO A FACTORY-BUILT (METAL) FIREPLACE

When installing into a zero clearance fireplace, The firebox must accept the insert without modification other than removing bolted or screwed together pieces such as smoke shelf/deflectors, ash lips, screen or door tracks, and damper assemblies. These items must be re-installed if the insert is removed and not replaced. The removal of any part must not alter the integrity of the listed fireplace in any way.

The factory built fireplace must be listed per UL 127. Installation must include a chimney liner (4" Pell Vent "PL" Piping) that extends the full height of the chimney and meets type HT requirements. The liner must be securely attached to the insert and the chimney top. The chimney must be sealed either at the top or at the damper area with a non-combustible plate to prevent room air passage to chimney cavity.

For raised hearth installations, adjust the leveling bolts under the front of the unit.

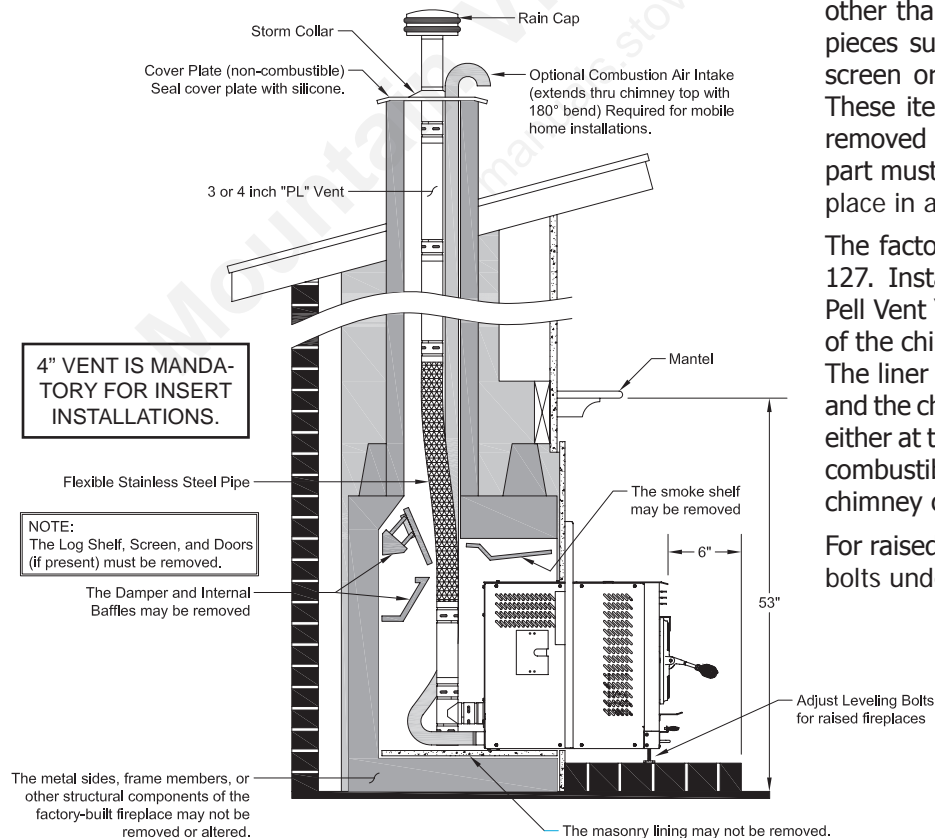

GLASS MAINTENANCE, REMOVAL AND REPLACEMENT

Your **Multi-Fuel Heater** comes to you with the glass door installed in place, ready for use. The glass is surrounded on the edges with a gasket and seated in a glass channel. It is held in place with two (2) clips.

REMOVAL OF BROKEN OR DAMAGED CERAMIC GLASS

Open the door and then lift it off of the hinges. If the door is tight, tap gently on the bottom of the door with your hand or rubber hammer. Lay door down on newspaper with glass clips facing you. Using a #2 Phillips screwdriver, loosen the screws and take off the glass clips. Remove the broken glass carefully and discard.

Reverse the above procedure for replacing new glass with new gasket. Do not over tighten the screws. Over tightening can cause the glass to break.

WARNING

**Do not operate unit with broken glass.
Do not substitute original factory glass.
You must use only factory authorized glass;
Do not slam door shut.
Do not strike glass.
Do not use abrasive cleaners.**

CLEANING THE GLASS

When the fire is first started, it will produce some smoke. The soot might accumulate on the glass surface. Before the glass surface gets hot, open the door and wipe the glass surface off with a rag. Do not touch the surface with your hands. If after constant use, the glass is dirty, you must clean the glass so that it will not become etched with the fly ash. When the glass has cooled off, take a damp rag and clean with **Hearth Glass Cleaner** available from your dealer. Do not use a rag that contains nylon because it will melt to the glass.



UNDERSTANDING THE CONTROL BOARD

CONTROL PANEL

Turning the heater OFF/ON, as well as adjustments for the fuel feed rate and room fan speed are performed by pressing the appropriate button(s) on the control panel which is located on the lower left-hand side of your American Harvest heater. The insert model 6041I is located on the left facade.

This unit has two fuel operation modes for different fuels, corn or pellet. It may also be changed between an automatic operation or a manual operation in either of the fuel modes. The heater comes from the factory in the corn mode.

Pressing the "ON" button on the control panel will begin the start-up sequence for the heater. The start-up sequence differs depending on which fuel operation mode you select. See Lighting Instructions for details. Pressing and holding the "ON" button will rotate the auger continuously until button is released, which feeds additional fuel.

Pressing the "OFF" button on the control panel will cause the heater to enter its shut-down sequence. The fuel feed system will stop pulling fuel from the hopper and, once the fire goes out and the heater cools down, the fans will stop running.

Pressing the "Heat Range" arrows, up or down, will adjust the amount of fuel being delivered to the burnpot.

The draft fan (exhaust) will come on as soon as the "ON" button is pressed. The fan will automatically adjust its speed in accordance to the heat range setting. However, this speed can be manually operated by pressing the "Draft Fan" arrows up or down. "Draft Fan" when pressed, the display will show "Df-A", which is automatic. Press the arrows again to adjust fan speed. When adjusting the Draft Fan setting, try only 1 setting above or below the heat setting. It is better to leave the heater in the automatic mode and adjust the manual draft slide to control the combustion air.

The room fan will come on once the unit has reached operating temperature (approx. 110°F). By pressing the "Room Fan" buttons, the display will show "Rf-A" which is automatic or "Rf-1" through "Rf-9" for manual settings. In auto mode, the room fan's speed will automatically be adjusted in accordance with the heat range setting. By pressing the "Room Fan" up arrow, you can adjust the fan speed setting up to "Rf-9". The fan speed can be adjusted to a higher setting than the heat setting but not lower than the corresponding heat range.

The "Aux" button is for Agitator operation. When the unit is "OFF" and the heater is cool, pressing the "Aux" arrows will rotate the agitator for easy removal for cleaning. The agitator, when in Automatic mode, will operate at set intervals. However, these can be changed by pressing the arrows on the "Aux" button. The agitator can be adjusted from 0 to 9, setting "0" is off and setting "9" is high.

The "Auger Delay" button can be used to pause rotation of the Auger and Agitator for approx. 1 minute. This can be cancelled by pressing the "ON" button. The "Auger Delay" is normally used only during the start up cycle to slow the fuel delivery down during the initial ignition.

The "Mode" button is used to switch between manual and automatic mode. When in auto mode, the fan, auger, and agitator will operate at preset intervals unless changed manually using the buttons mentioned above. When in manual mode, the draft fan (exhaust) will operate at full speed (100%), so the air must be controlled with the manual slide damper just below the viewing door. When the heater is in the manual mode, the optional thermostat will not properly control the unit.

During normal operation, the unit is constantly monitored for problems. In the event of an error condition, the unit will stop and an error will be displayed. See the list of error codes found at the end of this manual.

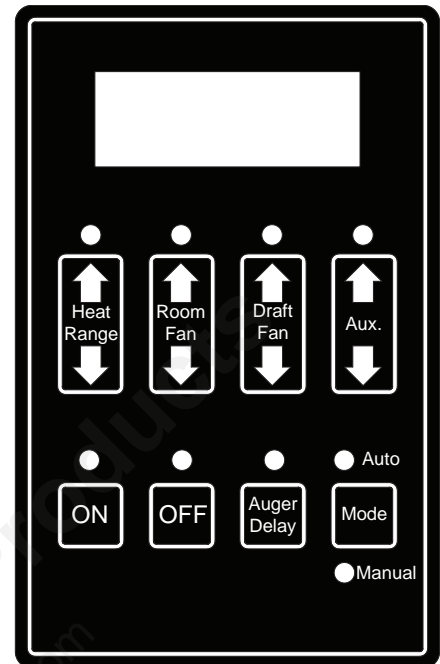

LIGHTING INSTRUCTIONS

CAUTION: DO NOT USE CHEMICALS OR FLUIDS TO START THE FIRE. HOT WHILE IN OPERATION. KEEP CHILDREN, CLOTHING AND FURNITURE AWAY. CONTACT MAY CAUSE SKIN BURNS.

Before lighting your heater for the first time, make sure that all items are out of the hopper, ash pan and firebox area.

Close all doors and lids. Choose which fuel setting that you wish to operate in, Corn or Pellet. Do this by first pressing the "ON" button, then press the "Heat Range" Up and Down arrows together for approximately 3-4 seconds and release. A "C" or "P" in the first digit of the display will indicate the mode. The ON LED will be blinking and the display will show "Cr-1" or "Pr-1", depending on the mode. The "Heat Range" indicator LED and the "Auto" LED should be lit and the dash in the Heat Range display should be flashing. You will notice the draft fan starts immediately. If you press the "Heat Setting" button up, the draft fan changes speed, increasing speed the higher the heat setting. You should begin to see the igniter, located in the center and behind the burnpot, begin to glow after a short period of time. In Corn Mode, the auger and agitator will start rotating after a few minutes, allowing for proper fuel ignition. In Pellet Mode, the auger will turn immediately, then the agitator will begin to rotate once the heater reaches operating temperature. **Note:** The room fan will not operate at this time, as a temperature of at least 110 degrees must be reached before operating. If proper operation of your heater is confirmed, press the "OFF" button, then fill your hopper with the desired fuel. Ensure there is no foreign matter in your fuel, hopper or burnpot. You are now ready to light your Multi-Fuel Heater.

TO START A FIRE...

- **Never use gasoline, gasoline-type lantern fuel, kerosene, charcoal lighter fluid, or similar liquids to start or "freshen up" a fire in this heater. Keep all such liquids well away from the heater while it is in use.**

Using Wood Pellets: Ensure your display shows a "Pr" for pellets.

- Close all doors, lids, and cleanouts.
- Press the "ON" button and select desired heat range. This will start the ignition sequence.

At this point, the igniter will come on and run for preset time limit (approximately 9 minutes). The auger will begin to turn and feed fuel into the burnpot. After the 9 minutes or if the heater reaches operating temperature, the igniter will shut off and normal operation will begin.

- Make fine adjustments to the air/fuel with the damper located centered, under the hearth.
- Once the heater reaches warm temperature, the room fan will start to circulate air into the room.

If you would like to increase the life of your ignitor, you can run your heater in the "Cr" mode. However, you **must** place pellets in the burnpot, up to the igniter level as shown in the illustration below for auto ignition. Close the door and press the "ON" button. The igniter only runs approximately half the time in "Cr" as oppose to the "Pr" mode.

Using Corn, Soy Beans, Cherry Pits: Ensure your display shows a "Cr" for corn.

NOTE: Wood pellets MUST be used for auto ignition of the fuel. Corn, Soy Beans, and Cherry Pits have a higher flash point and requires more heat to combust as opposed to wood pellets. Trying to light the heater with a fuel other than wood pellets will decrease the life expectancy of your igniter cartridge.

The use of starter gel or starter pellets is not required for this heater.

- Fill the burnpot with wood pellets up to the level of the igniter port; See illustration.
- Close all doors, lids, and cleanouts.
- Press the "ON" button and select desired heat range. This will start the ignition sequence.

Once the wood fuel is ignited and the heater senses heat, the auger and agitator will begin to rotate, feeding fuel to the burnpot. **NOTE:** If the starting fuel is not burning hot enough, you may see the fire begin to go out as new fuel is being added. If this occurs, pressing the "Auger Delay" button will allow the auger to pause for 1 minute. Pressing the "ON" button will resume the auger if 1 min. is too long. If not enough fuel is the reason for not burning, pressing and holding the "ON" button will allow the auger to continuously deliver fuel until you release the button.

- Continue to observe the fire until most of the wood pellets have been consumed and only corn or your selected fuel is burning aggressively.
- Make fine adjustments to the air/fuel with the damper located centered, under the hearth. You should pull the damper out approximately 1 inch. It may need to be pulled out more or less depending on your selected heat setting and fuel quality. Try opening or closing by a 1/4 inch at a time.
- Once the heater reaches warm temperature, the room fan will start to circulate air into the room.
- **Overfire Protection** - If the heater is being overfired, burned too hot, the heater will automatically shutdown to avoid damage to components in the heater. Refer to "Lighting Instructions" for proper use.

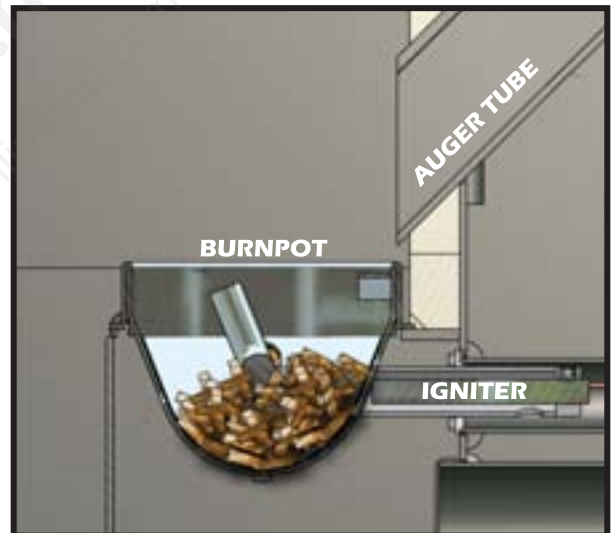

TURNING THE HEATER OFF

Pressing the OFF button will cause the heater to enter a shutdown mode. If the heater has reached operating temperature, the OFF Indicator will blink until the shutdown procedure succeeds in lowering the heater temperature. The Room Fan will stay on to cool the heater, and the Exhaust Fan will stay on to remove smoke and heat from the combustion chamber. The Agitator will rotate continuously until shutdown is complete. The Auger will bump the fuel out every few seconds to prevent the fuel in the auger from burning. Once the temperature of the burn chamber falls below approximately 90 degrees Fahrenheit and the pressure switch detects that the door is closed, the fans will stop and the Auger will run for a few seconds to purge the auger system of any burned fuel. At this point, the OFF Indicator will go out and the heater will turn completely off. If during burning, the heater reached at least 120 degrees Fahrenheit, the shutdown procedure will include a 15 minute shutdown cycle that will keep the heater in the shutdown state for at least 15 minutes regardless of whether it is cool or pressure is detected. The 15 minute cycle can be turned off by pressing the off button during shutdown. This will cause the system to exit shutdown and return to the "OFF" mode as soon as the door is closed and the heater is cool.

Continue to monitor the heater / insert after the shutdown procedure has begun. And remember, varying ambient conditions may result in a lengthy period of time for adequate cool down and the resultant shut down. Be patient, this is normal. The control board is telling the heater / insert to gradually "shut down," rather than initiate a sudden halt of fuel to the fire pot. In this way, the possibility of smoke entering the home is avoided.

- ① NEVER shutdown or unplug the heater and leave it unattended. Observe operations for at least 20 minutes.

DISPOSAL OF ASHES

Disposal of Ashes

Ashes should be placed in a metal container with a tight fitting lid. The closed container of ashes should be placed on a noncombustible floor or on the ground, well away from all combustible materials, pending final disposal. If the ashes are disposed of by burial in soil or otherwise locally dispersed, they should be retained in the closed container until all cinders have been thoroughly cooled.

MAINTENANCE INSTRUCTIONS

Soot and Flyash - Formation and Need for Removal

The products of combustion will contain small particles of flyash. The flyash will collect in the exhaust venting system and restrict the flow of flue gases. Incomplete combustion, such as occurs during startup, shutdown, or incorrect operation of the room heater will lead to some soot formation which will collect in the exhaust venting system. The exhaust venting system should be inspected at least once per month (of heavy use) to determine if cleaning is necessary. Corn has a high ash content.

Daily Maintenance

- **Surfaces on the front of the heater will be extremely hot during operation.** Always wear heat resistant gloves to perform periodic maintenance.
- Using a wooden stick, tap the side heat exchangers that are located on the left and right sides of the firebox. When you open the door, they are located directly inside to the left and right. When you tap the sides with the wooden stick the loose fly ash will drop out of these holes.
- Inspect inside heater for excessive ash build up. You will learn some fuels produce more ash than others. If excessive, remove the inside ash clean-outs. Once you have cleaned out the ashes, replace the clean-outs. Depending on your fuel and use, these clean-outs may be removed only weekly.
- If clinkers develops in the firepot, clean thoroughly. You may have to do this once or twice a day depending on the moisture content of the corn. If this is not cleaned out, it could cause the agitator to jam. USSC highly recommends an additive (see Fuel Additive) be added to your corn to eliminate these clinkers. Contact your local dealer for availability and cost. You will need this additive if the agitator "fingers" develop an accumulation or build-up.
- The clinkers on the agitator and burnpot are easily removed when soaked in warm water for 10 minutes.
- The ash pan (especially the model 6041I) should be cleaned out on a daily basis or as needed depending ash build-up.

SPECIAL CLEANING/OPERATIONAL INSTRUCTIONS:

After cleaning or when operating the heater, you need to make sure that "both" clean-outs are in their proper position. If left out or placed incorrectly, the combustion air is effected greatly and the heater will not burn properly.

Also, make sure that the ash dumps on each side of the damper are pushed in completely. This will also effect the combustion air.

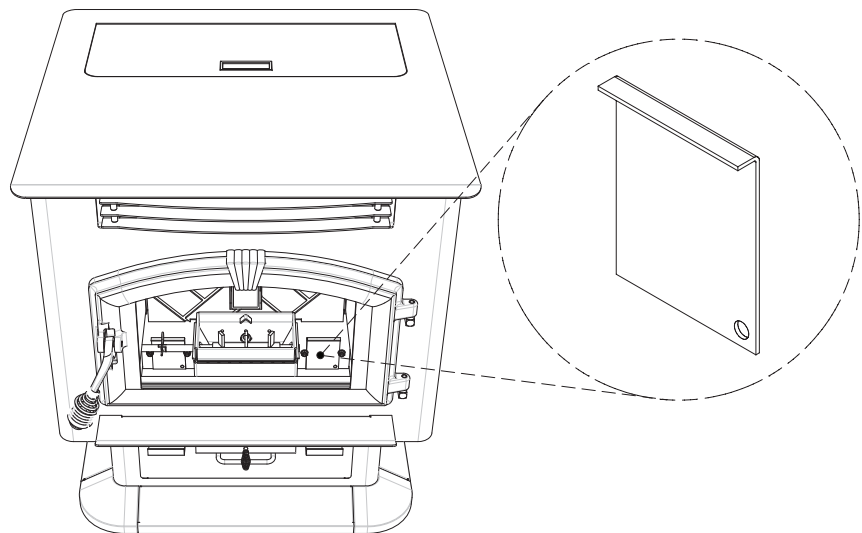

Weekly Maintenance

- Shut down the heater as directed in the operating instructions. Allow the heater to cool to room temperature. Remove the small clean-out slides in the lower corners of the firebox. Tap the sides of the burn chamber with a wooden stick. Do not tap the firewall behind the burn box as it may damage the ceramic firebrick. Scrape the fly ash from the clean-out chambers toward the front of the burn chamber. Remove the fly ash from the burn chamber and replace the clean-outs.
- Remove the ash pan and dump the ash into a metal container.
- Cleaning of the exhaust system will depend upon the ash and debris content of your fuel. If your fuel has a high ash content and/or significant debris in it, your exhaust system will require weekly cleaning. Cleaner fuels will allow for monthly cleaning of the exhaust system. Remove the exhaust pipe from the back of your heater and remove any ash that may have collected in the pipes. Replace the pipes to the heater and seal with high temperature seal tape. If you have installed proper clean out tees you will not have to take the chimney sections apart.

Spring Cleaning

When the heating season is over make sure that you clean out all of the fuel in the hopper, firebox area, ash pan and firepot area. Corn and any ash can accumulate moisture over the summer months causing the unit to rust and the fuel to mold. Corn left in the unit will attract mice and can cause internal wiring and insulation damage.

When the unit is cleaned out, take the venting apart, clean out the fly ash, rinse the venting out with a water hose and let dry, take the draft fan off and clean, clean out all areas such as back heat exchanger and lubricate the auger, auger tube, firepot area, agitator shaft and bearings and hopper area with a light oil (something like Pam cooking oil works great to coat the inside of the unit and the moving parts). Clean the glass, doors and outer cabinet so that you are ready for the next heating season. Use of a wet/dry vacuum makes all cleaning easier.

AUTOMATIC SAFETY FEATURES

WARNING

These automatic safety features must not be bypassed

Power Outage

- During a power outage, the heater will shut down. It will not automatically restart when the power returns, unless the heater is still above the proper operating temperature and a flame still exist in the burnpot.

Overheating

- A high temperature switch will automatically shut down the heater if it overheats. The heater will need to be manually relit. Allow 45 minutes before relighting.

Hopper Safety Switch and Pressure Switch

- If the hopper lid is open, or if the front viewing door is not closed properly, the auger will not operate.

FUEL ADDITIVE

Chicken Scratch for my Corn Burner?

Yes - Crazy as it may sound, ground Oyster Shells, (calcium carbonate) same as fed to chickens, is the ideal additive to promote clean burning, especially when the Corn Fuel is extra high in starch. And it's available at your local Feed and Seed.

The "average" mixture is 1/2 pound of Oyster Shells (about 2 handfuls) to 60 pound of Corn, a full hopper. IF the "fingers" on your agitator (stirrer or rouser) have a noticeable buildup of "clinkers" or stubborn deposits, you have either a high starch fuel OR are burning with too much air for proper combustion and are reaching the "fusion" temperature of the Potassium and/or Starch in the Corn. You need Oyster Shells - and maybe more than a couple handfuls.

If you notice a heavy accumulation of "whitish powder" in your burn pot, reduce the amount of Oyster Shell Additive.

Remember, using this additive- as necessary - promotes efficiency (higher heat output), reduces maintenance, clinkers and ash content.

CONTROL BOARD FUNCTIONS

START-UP SEQUENCE OF EVENTS

Once the control panel is turned on, a timer begins that will start, stop and continue operation of the Multi-fuel Heater as a preset temperature is achieved.

COMPONENT	OPERATION START	OPERATION END
Draft Fan	Starts Immediately	Will continue until shutdown. Shutdown will occur when the operating temperature is below approx. 90 degrees.
Agitator	Begins to turn once the heater reaches operating temperature	Will continue intermediately, as determined by the "HEAT SETTING", until shutdown.
Auger	In Pellet mode: Auger turns immediately. In Corn mode: Three minutes after starting, the auger will begin to turn	The auger will continue at the feed rate specified by the "HEAT SETTING". NOTE: Safety switches, HI limit and vacuum sensor, must be activated to continue proper operation.
Room Fan	Begins to run when heater reaches operating temperature	Will continue to operate until the heater cools down to below approx. 90 degrees. This may take several hours.
Automatic Shutdown	If after 15 minutes, the heater has not reached the preset operating temperature, the unit will begin to automatically shut down.	Should the timer expire before the preset operating temperature is achieved, simply reset the heater by pressing the "ON" button.
Normal Operation	If after 15 minutes the preset operating temperature of approx. 110 degrees is achieved, normal operation will continue.	Operation will continue until either the heater's control is to the "OFF" position, or the operating temperature falls below approx. 90 degrees. At such time the heater will default to the "Automatic Shut Down".
Igniter	Starts immediately	Will continue operation for a preset time, then shut-off

SHUTDOWN SEQUENCE OF EVENTS

Once the Heater has reached the normal operating temperature and switched to the "OFF" position, the unit will initiate a slow down, reducing the fuel rate until the heater's "LOW LIMIT SAFETY" sensor tells the control board it is safe to shutdown.

COMPONENT	SHUTDOWN	OPERATION END
Draft Fan	Unchanged operation until preset "OFF" temperature is achieved.	Continues until the operating temperature falls below approx. 90 degrees. May take several hours.
Agitator	Rotates continuously until preset "OFF" temperature is achieved.	Continues until the operating temperature falls below approx. 90 degrees.
Auger	Slows down to a reduced fuel setting until preset "OFF" temperature is achieved.	The auger will continue at the reduced feed rates until the operating temperature falls below approx. 90 degrees. NOTE: Safety switches, HI limit and vacuum sensor, must be activated to continue proper operation.
Room Fan	Unchanged operation until preset "OFF" temperature is achieved.	Will continue to operate until the heater cools down to below approx. 90 degrees. This may take several hours.
Automatic Shutdown	If the heater's "HI LIMIT" sensor snaps open, this will cause an automatic shutdown. An error code will be displayed (Err1). NOTE: "HI LIMIT" errors are usually the result of operating at the highest heat setting for long periods of time, room fan failure or loose wire connection.	It is rare that the HI LIMIT temperature is reached. However, should this error occur, let the heater cool down for an hour then restart.

CAUTION: When performing any internal electrical maintenance

- Moving parts inside of the cabinet may cause injury. Do not operate unit with panels removed or open.
- **HOT** parts. Do not operate the unit with panel open.
- Risk of electric shock. Disconnect power before servicing unit.
- In the event of component failure, replace with the original factory equipment.

ERROR CODES and DISPLAY INDICATORS

Error Code	Error Description	Possible Causes
Err1	The high limit temperature sensor has tripped.	<ul style="list-style-type: none"> Inadequate ventilation. Room fan failure. Exhaust Blockage. Electrical Open in the over temperature switch or wiring.
Err2	The low limit temperature sensor has tripped.	<ul style="list-style-type: none"> Hopper Empty. Auger output failure or jam. Poor flame or fuel quality caused fire to burn too slowly or go out. Electrical Open in low temperature switch or wiring. Fire was not well established before the PCB's programmed time limit expired.
Err3	The heater was unable to reach the Room Fan On temperature within the startup time.	<ul style="list-style-type: none"> Poor flame or fuel quality caused fire to burn too slowly or go out. Auger output failure or jam Hopper empty on startup.
Err4	The power failed while the heater was hot, and when power was restored, the fire was out.	<ul style="list-style-type: none"> Electrical Open in low temperature switch or wiring. Power loss
Err5	The Auger output fuse has blown.	<ul style="list-style-type: none"> Auger motor jammed or bad.
Err6	The Agitator output fuse has blown.	<ul style="list-style-type: none"> Agitator motor jammed or bad.
Err7	The Draft Fan (Exhaust Fan) output fuse has blown.	<ul style="list-style-type: none"> Draft Fan motor jammed or bad.
Err8	The Room Fan output fuse has blown.	<ul style="list-style-type: none"> Room fan motor jammed or bad.
Err9	Zero Crossing Input failed	<ul style="list-style-type: none"> AC supply frequency out of range.
Err10	The Igniter output fuse has blown	<ul style="list-style-type: none"> Igniter output has shorted/blown or igniter overload.

Display Indicators

Several situations or events are indicated in normal operation by blinking display indicators or segments in the display:

Flashing On Indicator: This means that the heater is in the "Start Up" awaiting for the ignition procedure to complete.

Flashing Off Indicator: This indicates that the heater is in the "Shutdown" state waiting for the OFF button, or for a 15 minute period after the heater was turned off, or for the heater to cool down, or for the door to be closed.

Flashing dash in Heat Range Display: This indicates that the heater is in the normal run mode and is ramping from the current heat range setting to the target heat range setting. Once the ramp is complete, the dash will stop flashing. For ramping from heat range 1 to 5, the default time is 12 minutes (with a 90 second ramp time).

Flashing heat range value in "Heat Range" display: For example, if the display is showing "Hr-3" and the '3' is blinking, this indicates that the heater thermostat input is open and not calling for heat. While this is happening, the actual heat range value is 1 (low).

Flashing Automatic Mode Indicator: This indicates that the heater is in normal operation and is running in the automatic mode. However, either the Draft Fan or Auxiliary setting is manually configured.

Flashing Draft Fan Setting Indicator: This indicates that the heater is in normal operation and that the vacuum sensor detects a loss of pressure either because the door is open or because there is a negative pressure in the room with respect to the exhaust.

Flashing Aux Indicator: This indicates that the igniter is on during the lighting stage.

Quick (changes twice per second) Flashing Heat Range Setting Indicator : This indicates that the heater is in normal operation and that an over temperature condition exists causing the fuel to stop.

Slow (changes once per second) Flashing Heat Range Setting Indicator : This indicates that the heater is in a cutback condition in an attempt to prevent an over temperature shutdown.

Factory Defaults

To return the control to its original factory default settings, press and hold the AUX UP and AUX DOWN buttons together for three seconds.

TROUBLE SHOOTING

① **Disconnect the power supply before performing any maintenance! NOTE: Turning the heater to “OFF” does not disconnect the power to all of the electrical components of the heater.**

① **Never try to repair or replace any part of the heater unless instructions for doing so are given in this manual. All other work should be done by a trained technician.**

PROBLEM	CAUSE: Too rich air/fuel mixture
Orange, lazy flame, excessive fuel build-up in the burnpot.	<ul style="list-style-type: none"> • Clean out the burnpot • Make sure the cleanouts on each side of the damper are closed completely. • Not enough combustion air. Adjust the air damper to a more open position. • Make sure that the viewing door is closed and sealed properly. If not, adjust the door catch or replace the gasket. • Check that all outside connections are clear of any obstructions. • Check the exhaust system, clean as needed.
PROBLEM	Cause: Burnpot out of fuel
Fire goes out or heater shuts down	<ul style="list-style-type: none"> • Hopper is empty, refill the hopper • Loss of draft pressure. Make sure the viewing door is closed and sealed properly. Check the outside connections for any obstructions. Check the exhaust system; clean as needed. • Check that the pressure switch connection to the firebox is free of ashes or clear of any obstructions. • Auger system may be jammed or there is a “bridging” of fuel in the hopper preventing fuel flow into the auger feed system. • Too much combustion air. Adjust damper to a more closed position.
PROBLEM	Cause: Auto-Start Igniter fails to ignite the fuel in the burnpot.
Heater does not start a fire when the “ON” button is pressed.	<ul style="list-style-type: none"> • Check the pellets quality. If moist or damp, replace with dryer fuel. • Check that the auto-start igniter port is not blocked with ash or soot. (The igniter is located behind the burnpot.) • The auto-start igniter should glow on start-up. If you can not visible see the igniter glowing, then it may need to be replaced or there is a problem with the electrical system. Check wiring. • Loss of draft pressure. Make sure the viewing door is closed and sealed properly. Check the outside connections for any obstructions. Check the exhaust system; clean as needed.
PROBLEM	Cause: Not enough combustion air or fuel has too much moisture.
Viewing glass becomes black shortly after start-up.	<ul style="list-style-type: none"> • Adjust the air damper to a more open position. • Use a fuel with less moisture content.
PROBLEM	Cause: Not enough combustion air or fuel has too much moisture.
“Black Popcorn” is present in the burn chamber.	<ul style="list-style-type: none"> • Not enough combustion air. Adjust the air damper to a more open position. • Check moisture content in corn. Use corn with a moisture content of 11-12% or less.
PROBLEM	Cause: Corn is wet or has a high moisture content.
Corn builds up in burnpot or is not burning completely. Steam is coming from corn.	<ul style="list-style-type: none"> • Not enough combustion air. Adjust the air damper to a more open position. • Check moisture content in corn. Use corn with a moisture content of 11-12% or less.
PROBLEM	Cause: Chemical reaction between the starches in corn and the heat.
“Clinkers” form in burnpot and on agitator.	<ul style="list-style-type: none"> • Adjust air mixture. • Add calcium carbonate (aka chicken scratch or oyster shell) • Try running a mixture of wood pellets and corn.

WIRING DIAGRAM

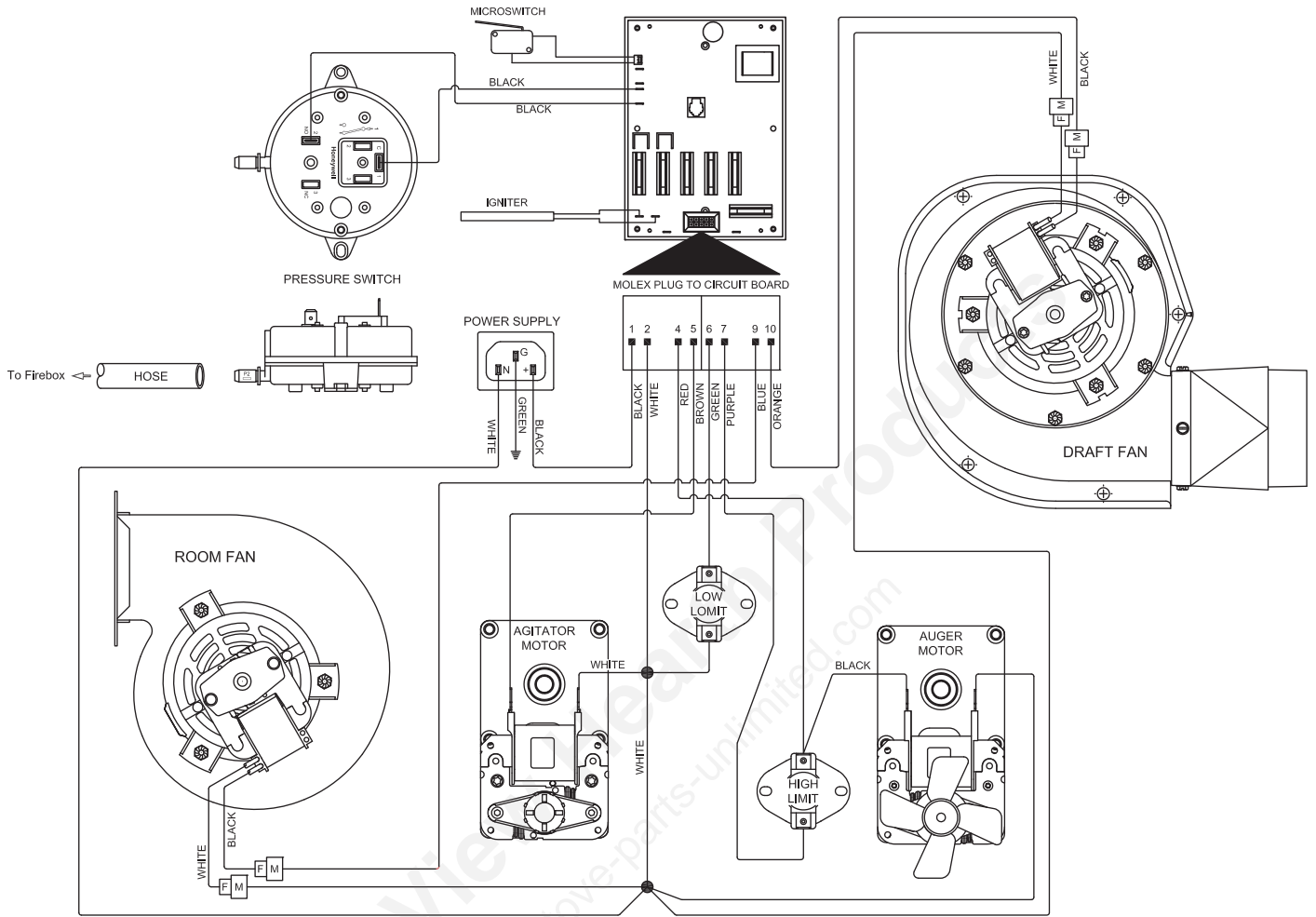

WIRING SCHEMATIC

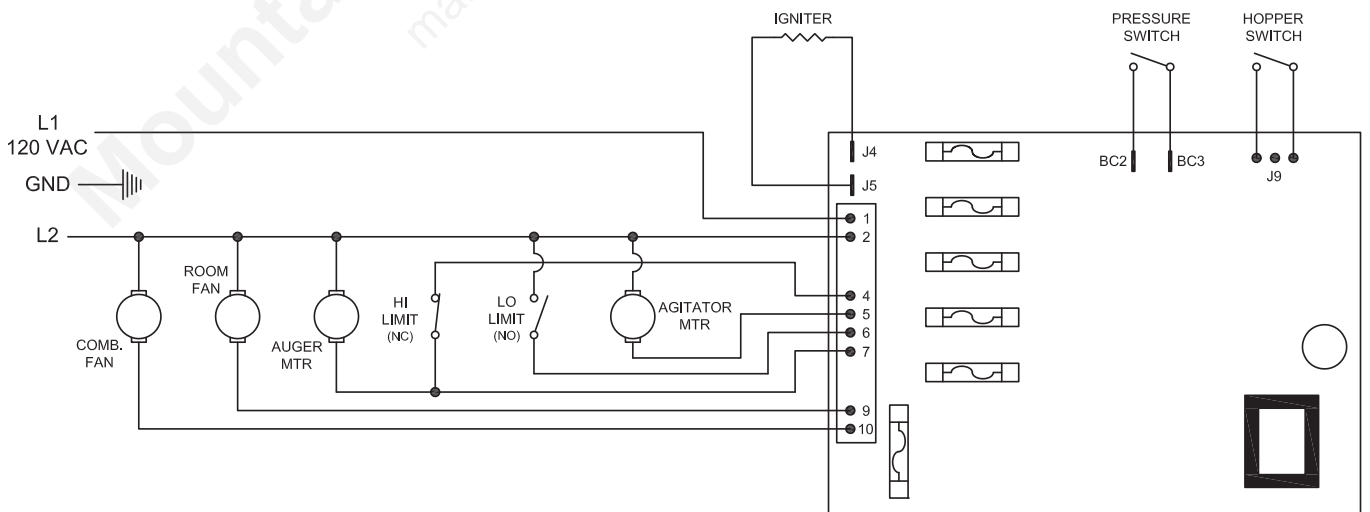

PARTS DIAGRAM - 6041TP

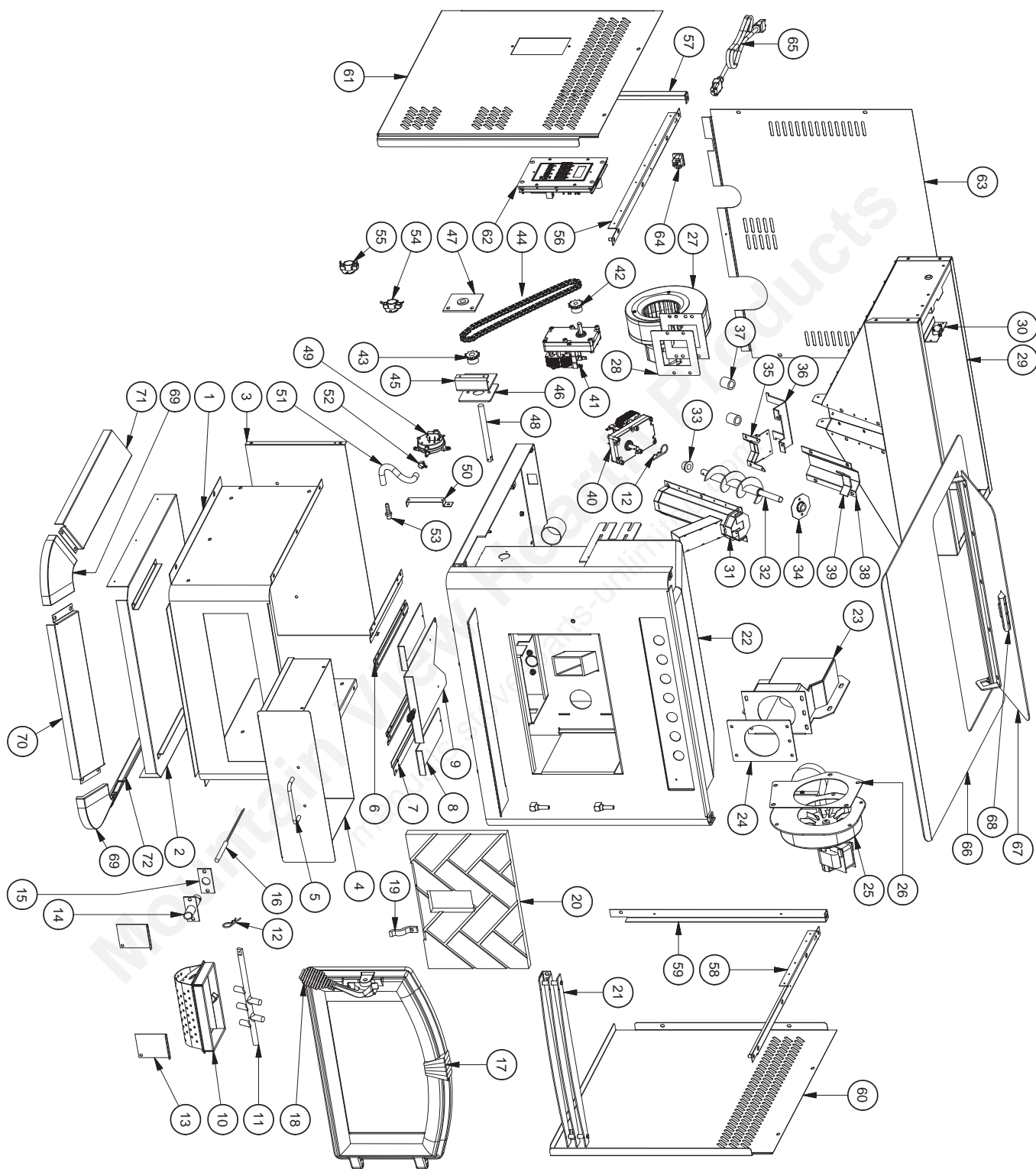

PARTS LIST - 6041TP

Key	Part No.	Description	Qty.
1	69529	Pedestal	1
2	25410	Pedestal Bottom	1
3	25451	Pedestal Back	1
4	69478	Ash Pan	1
5	891137	Handle	1
6	25533	Damper/Cleanout Guide	2
7	25532	Cleanout Guide	2
8	25531	Ash Cleanout (Lower)	2
9	69528	Damper	1
10	891660	Burnpot	1
11	891059	Agitator	1
12	83529	Hair Pin	2
13	25524	Ash Cleanout (Inner)	2
14	69593	Igniter Tube Weldment	1
15	88118	Igniter Flange Gasket	1
16	80543	Igniter Cartridge	1
17	69516	Feed Door Assembly	1
18	891135	Spring Handle (Large)	1
19	25080	Door Latch	1
20	891705	Vermiculite Board (Herringbone)	1
21	69497	Louver Assembly	1
22	88116	Insulation (Kaowool)	1
23	86627	Exhaust Duct	1
24	88114	Exhaust Duct Weldment	1
25	80473	Exhaust Blower	1
26	88100	Exhaust Blower Gasket	1
27	80472	Distribution Blower	1
28	88106	Distribution Blower Gasket	1
29	69598	Hopper Assembly - Complete	1
30	80491	Micro Switch	1
31	891164	Auger Housing Weldment	1
32	891141	Auger	1
33	891132	Bottom Bushing (Retaining Ring - Pt #: 83534)	1
34	69514	Top Bushing Plate Assy.	1
35	891248	Bottom Plate Retainer	1
36	891195	Drive Motor Bracket	1
37	891169	Hose (2 per)	0.167 ft

Key	Part No.	Description	Qty.
38	891180	Auger Cover	
39	88120	Gasket, 0.188 x 1.0 Flat FbrGls.	0.25 ft
40	80488	Drive Motor (Auger)	1
41	80456	Drive Motor (Agitator)	1
42	891083	Sprocket, Motor	1
43	891057	Sprocket, Shaft	1
44	891058	Chain - 36 Links	1
45	69594	Primary Bushing Assembly	1
46	88111	Agitator Bracket Gasket	1
47	69595	Secondary Bushing Assembly	1
48	891706	Drive Shaft - Agitator	1
49	80549	Pressure Switch	1
50	25648	Pressure Switch Bracket	1
51	891121	Silicone Hose	0.4 ft
52	83564	Hose Clamp	1
53	89586	Auger Nipple	1
54	80381	110°F Snap Disc (Low Limit)	1
55	80390	170°F Snap Disc (High Limit)	1
56	69506	Cabinet Support, Top/Left	1
57	25448	Support Frame, Back/Left	1
58	69505	Cabinet Support, Top/Right	1
59	25447	Support Frame, Back/Right	1
60	25412	Right Cabinet Side	1
61	25411	Left Cabinet Side	1
62	80575	PCB, Circuit Board	1
N/S	80485	Wiring Harness, Main	1
63	25682	Cabinet Back	1
64	80462	Receptacle, 3-Prong	1
65	80461	Power Supply Cord	1
66	891707	Top/Lid Assembly	1
67			
68	891148	Plastic Handle	1
69	25493	Corner Trim	2
70	25468	Trim, Front Panel	1
71	25472	Trim, Left Panel	1
72	25471	Trim, Right	1
N/S = Not Shown			

PARTS DIAGRAM - 6041I

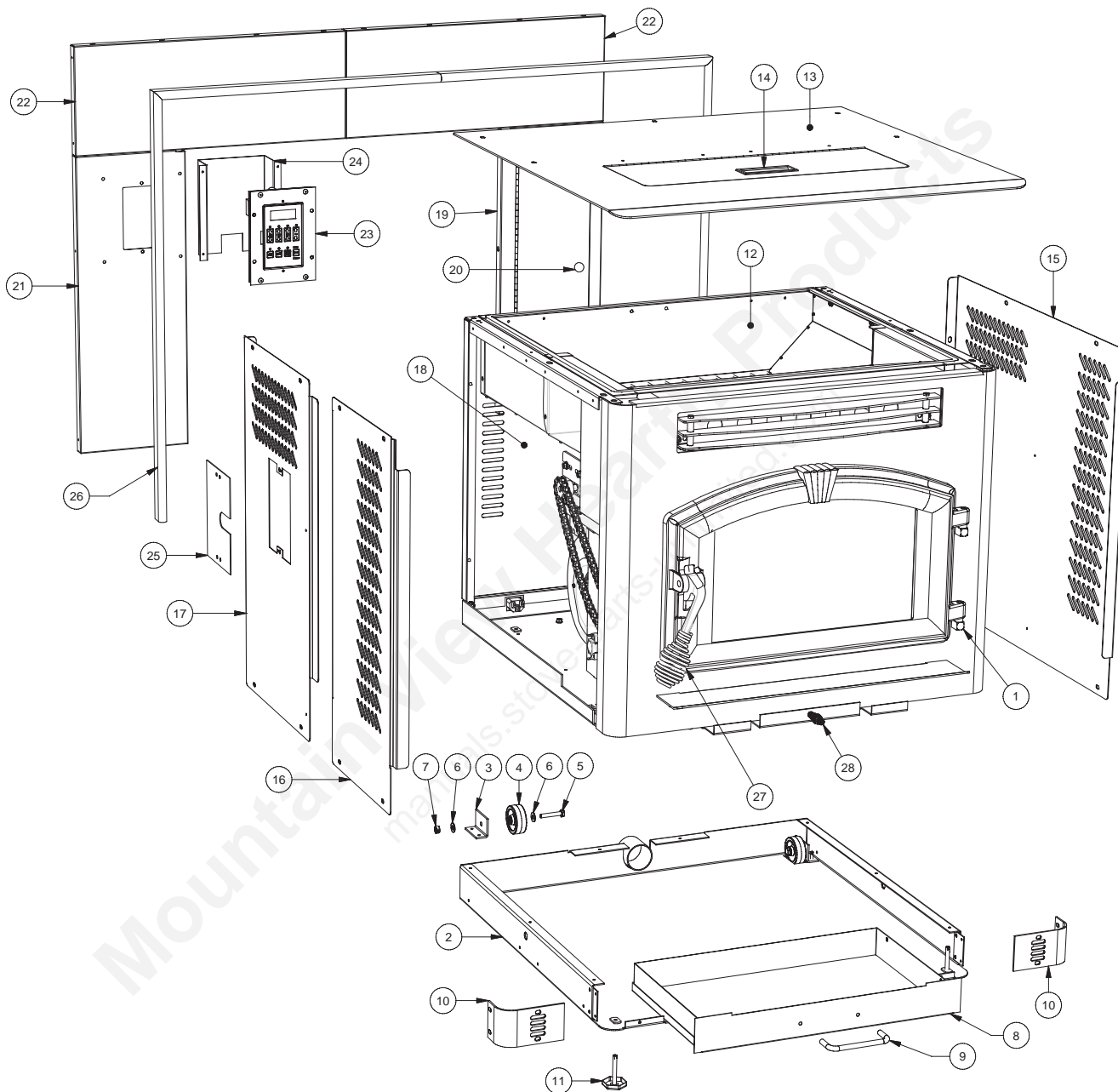

PARTS LIST - 6041I

Parts List	Key	Part No.	Description	Qty.	Key	Part No.	Description	Qty.
	1	891373	Pad, Door Hinge (Threaded)	2	17	25580	Left Side-Rear Cabinet	1
	2	69547	Weldment Sub-Base	1	18	25578	Back, Cabinet	1
	3	25569	Bracket, Caster	2	19	25587	Wldmt., Facade Panel Rt-Side	1
	4	891424	Caster, Plastic	2	20	89943	Knob, Cabinet Door	1
	5	83412	1/4-20 x 1-1/2 Hex Bolt	2	21	25585	Panel-Left Side Facade	1
	6	83136	Washer	4	22	25590	Top-Panel, Facade (2 piece)	2
	7	83261	1/4-20 Lock Nut	2	23	80575	Circuit Board (PCB)	1
	8	69548	Weldment, Ash Pan	1	24	25583	Cover, PCB	1
	9	891137	Handle (Brushed Nickel)	1	25	25582	Cover, Panel	1
	10	25570	Facade, Bottom	2	26	891435	Kit, Facade Trim (B-Lux)	1
	11	83479	Leveler	2	27	891135	Handle, Spring (Large)	1
	12	69619	Hopper Assembly	1	28	891331	Handle, Spring (Small)	1
	13	25586	Weldment, Cabinet Top	1	N/S	891299	Poker, Burnpot	1
	14	891148	Handle, Plastic	1	N/S = Not Shown Add the suffix "MB" to the part number of any painted part.			
	15	25581	Right Side Cabinet	1				
16	25579	Left Side-Front Cabinet	1					

Notice:

For all other repair components not listed above, refer to the 6041TP Repair list and diagrams for info.

PARTS DIAGRAM/LIST

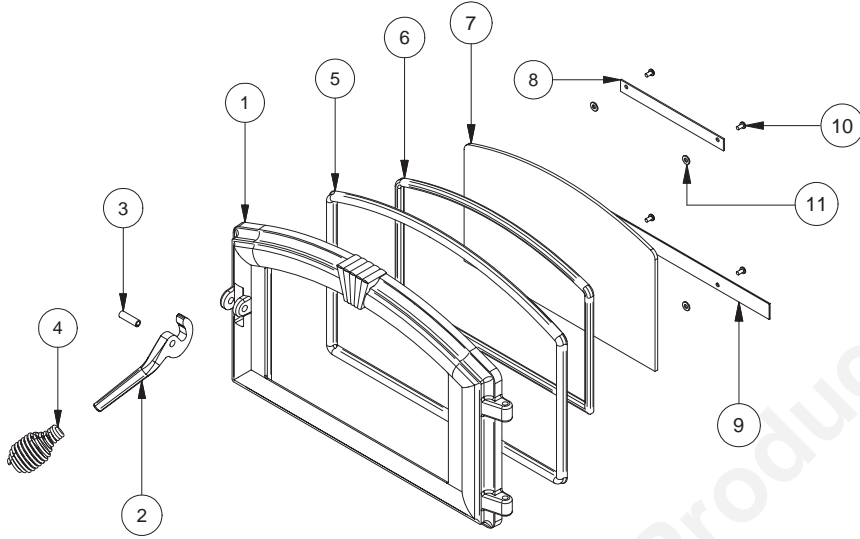

Parts List	Key	Part No.	Description	Qty.	Key	Part No.	Description	Qty.
	1	25491	Feed Door	1	7	891131	Glass Ceramic	1
	2	25492	Handle, Door	1	8	25464	Retainer, Top Glass	1
	3	83506	Roll Pin, 3/8 x 1-1/4	1	9	25465	Retainer, Bottom Glass	1
	4	891135	Handle, Spring (Parts Bag)	1	10	83202	Machine Screw	4
	5	88112	Gasket, 1/2" Sq. Rope	5 ft	11	83278	#10 Flat Washer	4
	6	88087	Gasket, Glass (1 x 3/16)	4 ft				

Louver Assembly (Part No.: 69540)

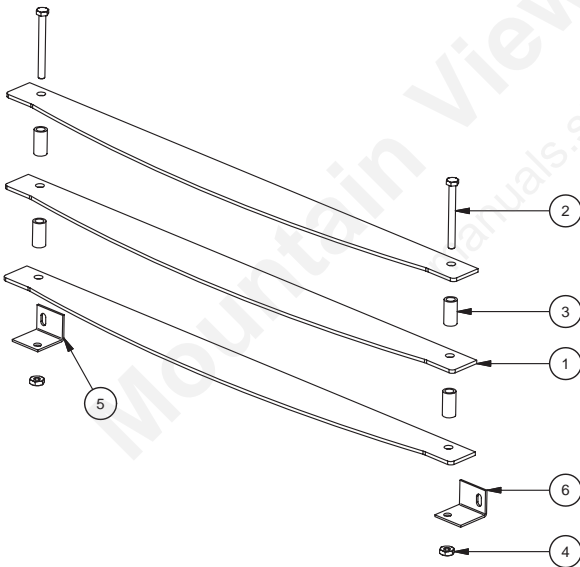

Parts List	Key	Part No.	Description	Qty.
	1	891334	Louver, Stainless Steel	3
	2	83531	Screw, 10-24UNC x 2" Long	2
	3	83532	Spacer	4
	4	83295	Nut, 10-24 UNC	2
	5	25444	Bracket, Louver (Left)	1
	6	25445	Bracket, Louver (Right)	1

6041HF Parts Diagram & List

NOTE:

For internal parts, cabinet parts, etc. see pages 21-22

Parts List	Key	Part No.	Description	Qty.
	1	25523	Leg, Cast Iron	4
	1a	891216	Leg, Steel (alternate to item 1)	-
	2	25425	Guide Rail, Ash Pan	2
	3	69622B	Ash Pan Weldment	1
4	891138	Handle, Nickel	1	

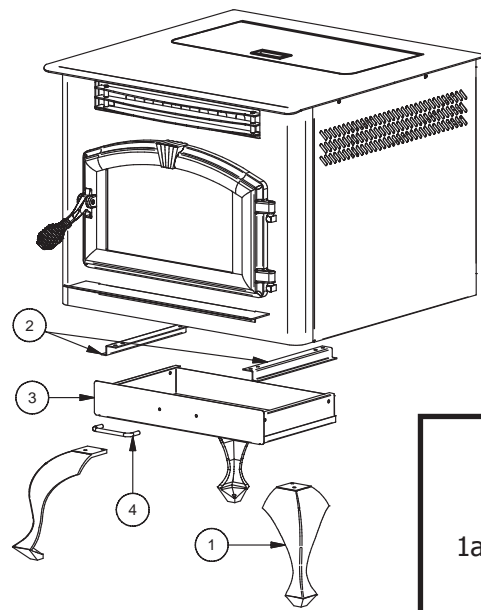

NOTE

Mountain View Hearth Products
manuals.stove-parts-unlimited.com

HOW TO ORDER REPAIR PARTS

This manual will help you obtain efficient, dependable service from the furnace, and enable you to order repair parts correctly.

Keep this manual in a safe place for future reference.

When placing an order or for warranty claims, please provide the following information found on the Certification Plate located below the ash door.

PART NUMBER

PART DESCRIPTION

MODEL NUMBER - 6041 / 6041TP / 6041HF / 6041I

SERIAL NUMBER _____

United States Stove Company

227 Industrial Park Road
P.O. Box 151
South Pittsburg, TN 37380
(423) 837-2100

Customer Service: (800)-750-2723 • Repair Parts: (888) 299-1440