

ADVANTAGE II - T
ADVANTAGE III
PELLET STOVES

Mountain View Hearth Products
manuals.stove-parts-unlimited.com

WHITEFIELD TECHNICAL TRAINING MANUAL

ADVANTAGE PELLET STOVE CUT-A-WAY- DIAGRAM PARTS LIST

- | <u>Description</u> | |
|---|--|
| 1. Advantage II-T Door Complete - Black
Advantage II-T Door Complete - Brown
Advantage II-T Door Complete - Slate
A. Center Window Trim
B. Side Window Trim (pkg. of 2)
C. Side Window Glass
D. Center Window Glass
E. Window Wash Bracket
F. Window Clip (bent)
G. Window CLip (flat)
H. Door Gasket - 8' x 1/2" | 18. Top Front Panel - Black
Top Front Panel - Brown
Top Front Panel - Slate |
| Advantage III Door Complete - Black
Advantage III Door Complete - Brown
Advantage III Door Complete - Slate
Glass
Window Wash Bracket
Door Gasket 8' x 1/2"
Bottom Window Clip
Side Window Clip | 19. Trivet - Black
Trivet - Brown
Trivet - Slate
Trivet - Gold |
| 2. Door Handle Assembly - Black
Door Handle Assembly - Brown
Door Handle Assembly - Slate
Door Latch Bolt
Wood Door Handle
Shoulder Bolt
Wave Washer
Flat Washer | 20. Hopper Lid with Hinge - Black
Hopper Lid with Hinge - Brown
Hopper Lid with Hinge - Slate |
| 3. Ash Pan Trim - Black
Ash Pan Trim - Brown
Ash Pan Trim - Slate | 21. Shoulder Bolt with Roller
22. High Limit Snap Switch (pkg. of 3)
23. Convection Fan Mounting Gskt.
24. Convection Fan |
| 4. Ash Pan | 25. Right Side Panel - Black
Right Side Panel - Brown
Right Side Panel - Slate |
| 5. Brick Retainer (Right) | 26. Control Board |
| 6. Brick Retainer (Left) | 27. Damper Handle |
| 7. Hinge Pin | 28. Damper Rod Collar |
| 8. Ultra Grate Base Plate Kit | 29. Damper Rod |
| 9. Ultra Grate | 30. Left Side Panel - Black
Left Side Panel - Brown
Left Side Panel - Slate |
| 10, 11, 12. Firebrick Set | 31. Combustion Fan Motor Only |
| 13. Ash Pan Door Assembly | 32. Combustion Fan Assembly |
| 14. Self Igniter Receptical Plug | 33. Combustion Fan Mounting Gskt. |
| 15. Ash Trap Baffle Kit | 34. Low Limit Snap Switch |
| 16. Door Hinge Bracket | 35. Damper Plate |
| 17. Heat Exchange Tube Scraper Rod | 36. Pressure Switch |
| | 37. Pressure Switch Hose |
| | 38. Air Inlet High-Limit Snap Switch |
| | 39. Auger |
| | 40. Auger Retention Plate Gasket |
| | 41. Auger Retention Plate |
| | 42. Set Collar & Screw |
| | 43. Auger Motor |
| | 44. Power Cord |
| | 45. Rear Inspection Panel - Black
Rear Inspection Panel - Brown
Rear Inspection Panel - Slate |

S:ADVT-P.DOC

WHITFIELD ADVANTAGE SERVICE MANUAL

ADVANTAGE EXPLODED VIEW

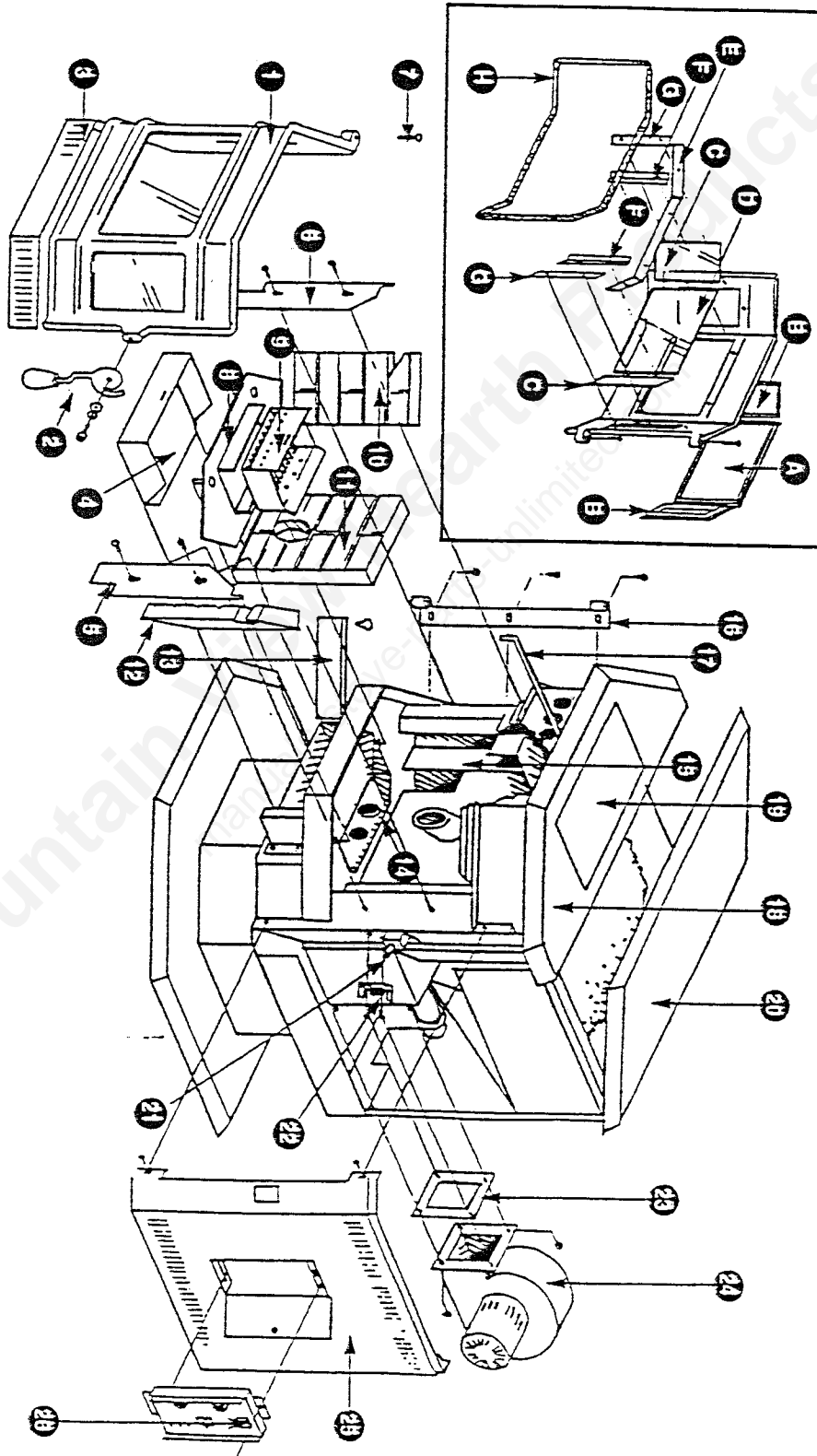

WHITEFIELD TECHNICAL TRAINING MANUAL

ADVANTAGE EXPLODED VIEW

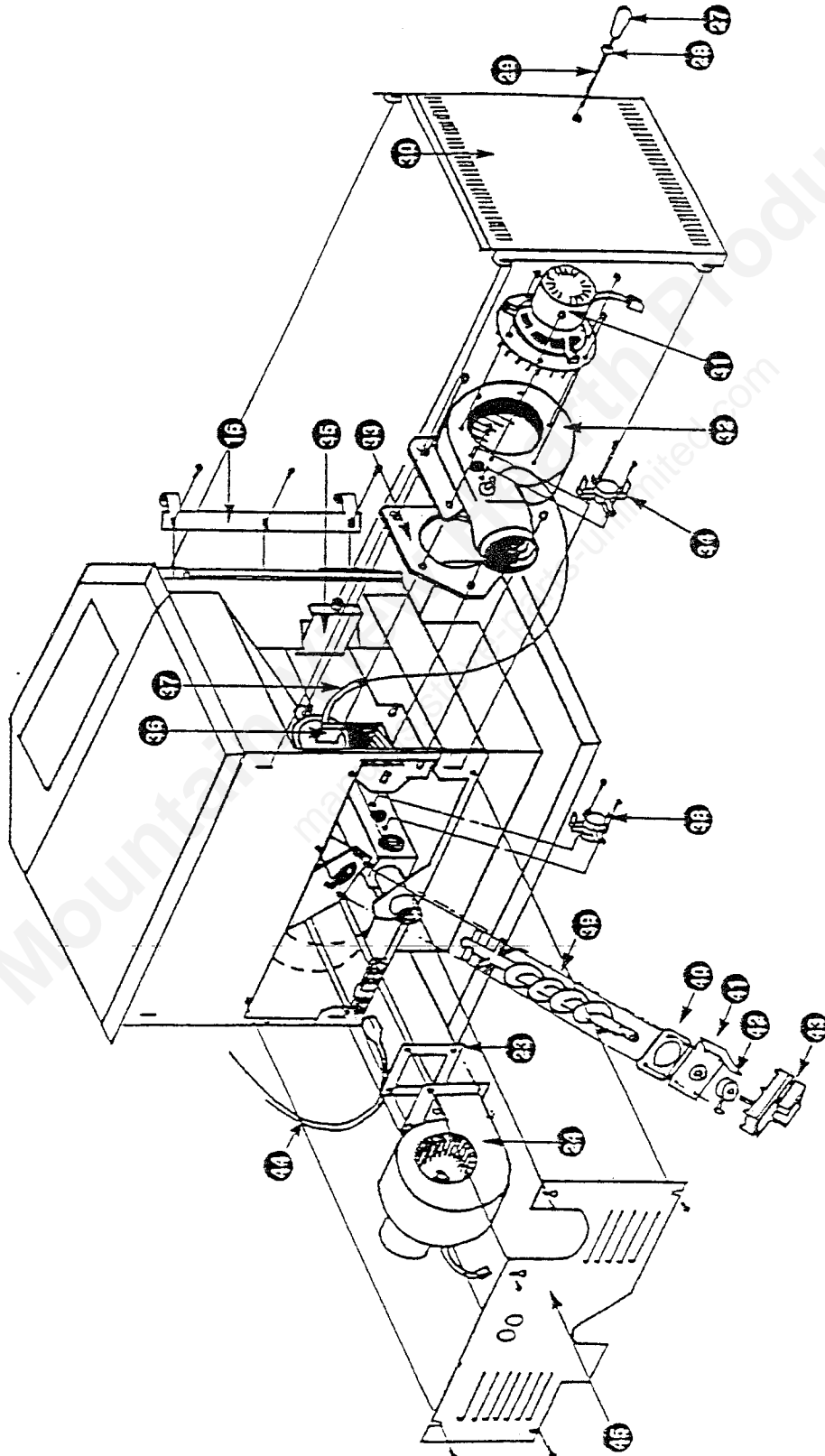

1994 Advantage Wiring Harness

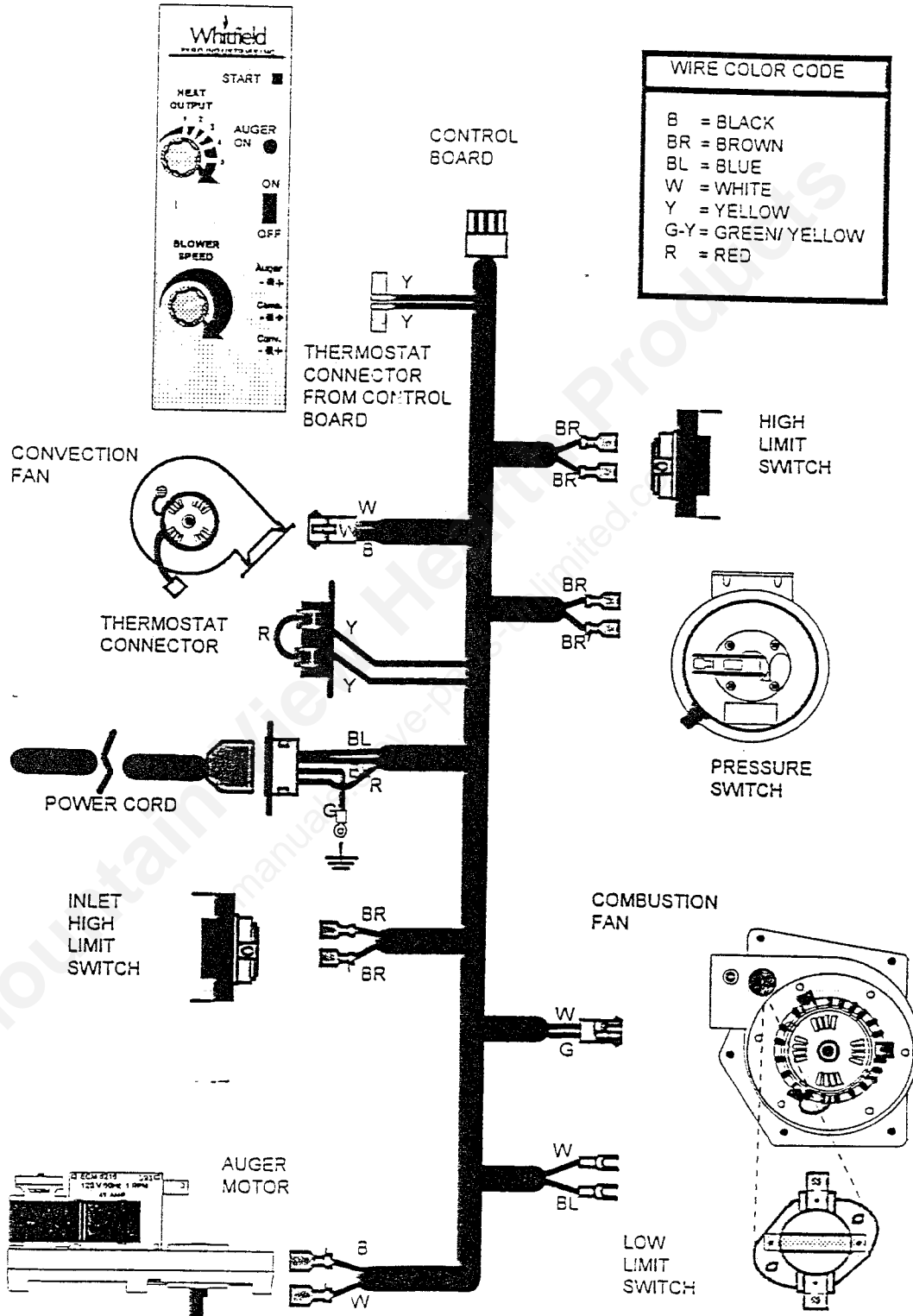

WIRING HARNESS / COMPONENT HOOKUP DIAGRAM
 (Serial # 75,364 and greater)

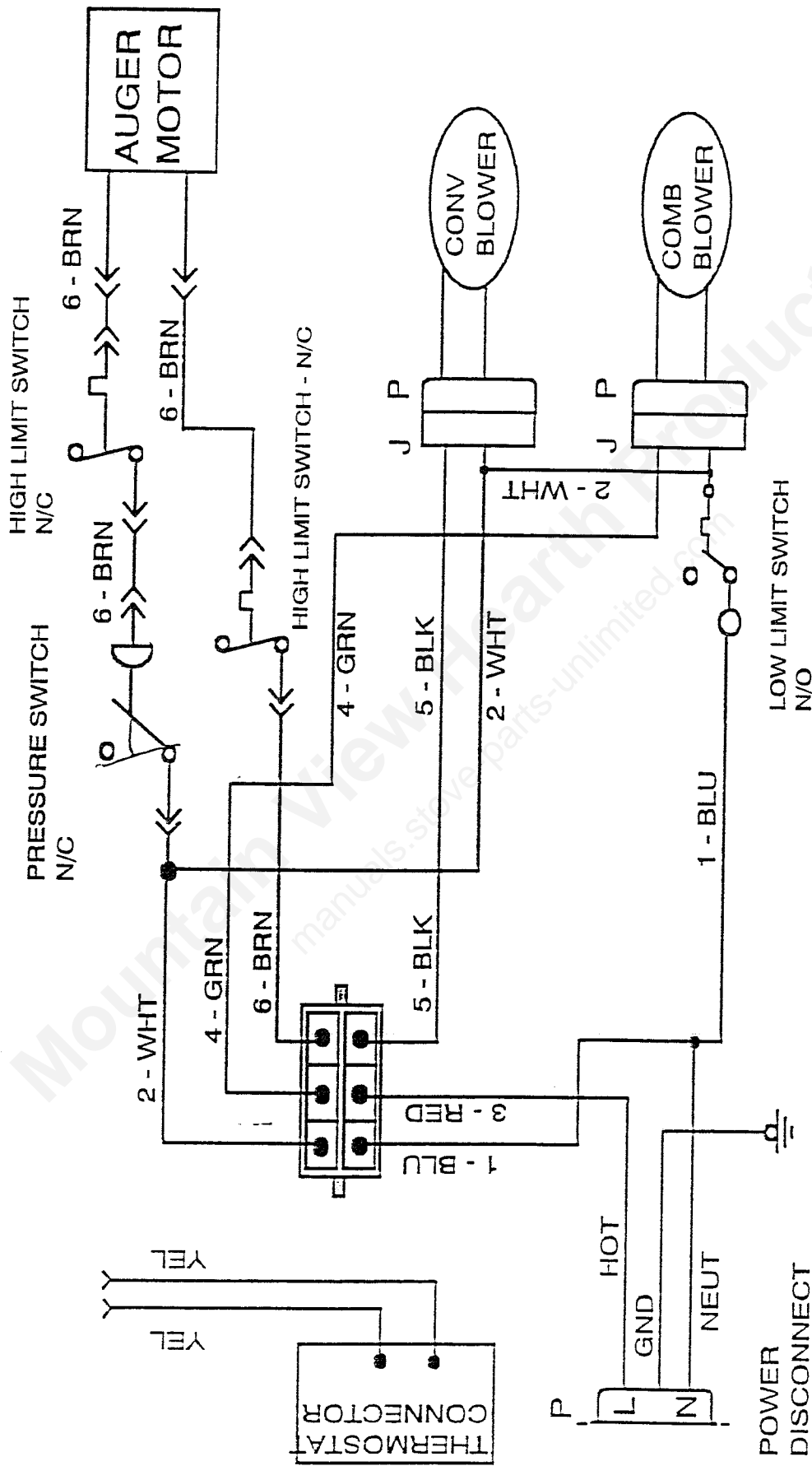

WIRING HARNESS CONFIGURATION (Serial # 75,864 and higher)

Whitfield
PYRO INDUSTRIES INC.

START 

HEAT
OUTPUT

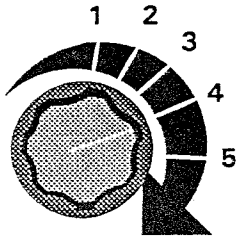

AUGER
ON 

ON 

OFF

BLOWER
SPEED

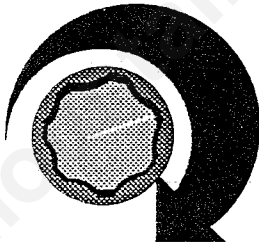

Auger

-  +

Comb.

-  +

Conv.

-  +

Board Specifications

Auger "ON" Time: 1.4 seconds

Auger "OFF" Time:

1. 7.0

2. 5.0

3. 3.0

4. 2.0

5. 1.5

Combustion Voltage:

1. 70

2. 73

3. 80

4. 87

5. 107

Convection Voltage:

Minimum: 70 Volts

Maximum: 113 to 120

Advantage II-T & Advantage III Control Board

Starting Serial Number: 91410

Combustion Fan
Voltage Trim Pot

Indicator Lights
"LED"S

Auger "ON" Time
Trim Pot

Voltage
Test Ports

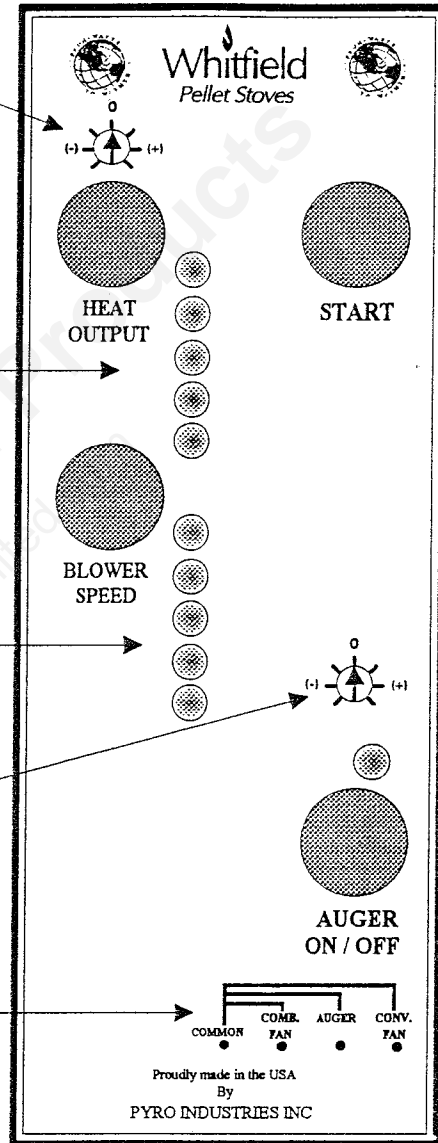

Board Specifications:

Auger "ON" Time: 1.4 seconds
 Auger "OFF" Time:
 1. 7.0
 2. 5.0
 3. 3.0
 4. 2.0
 5. 1.5

Combustion Voltage:
 1. 70
 2. 73
 3. 80
 4. 87
 5. 107

Convection Voltage:
 1. 60
 2. 65
 3. 70
 4. 75
 5. 85

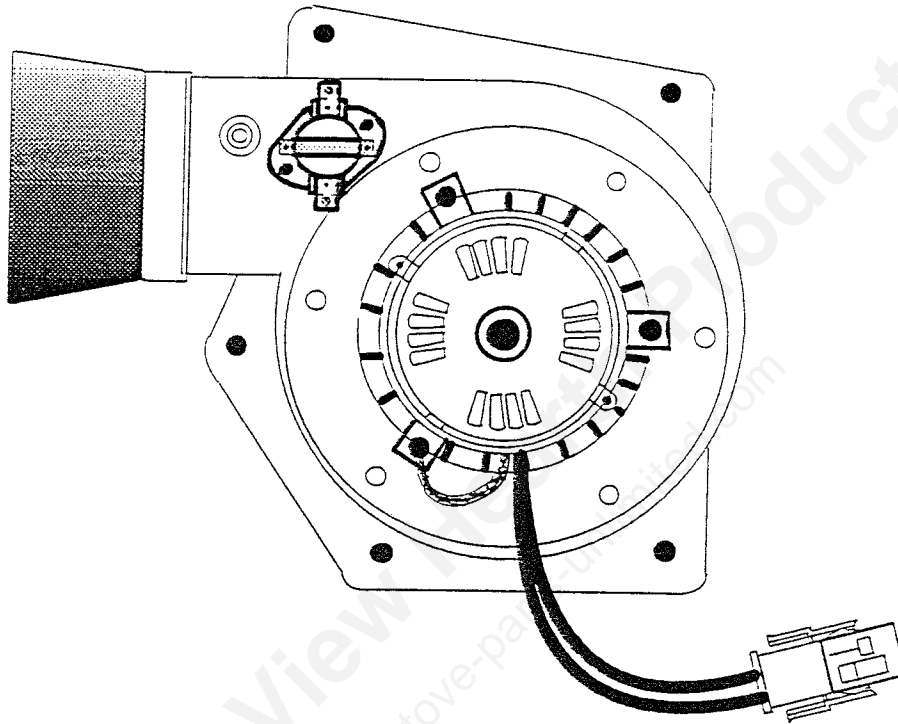

COMBUSTION FAN : PN # 12156009
(COMPLETE ASSEMBLY)

FASCO PN # 7021- 8786 TYPE U21B HP 1/70

115 V 60 HZ .95 AMP CLASS "B"

3000 RPM THERMALLY PROTECTED

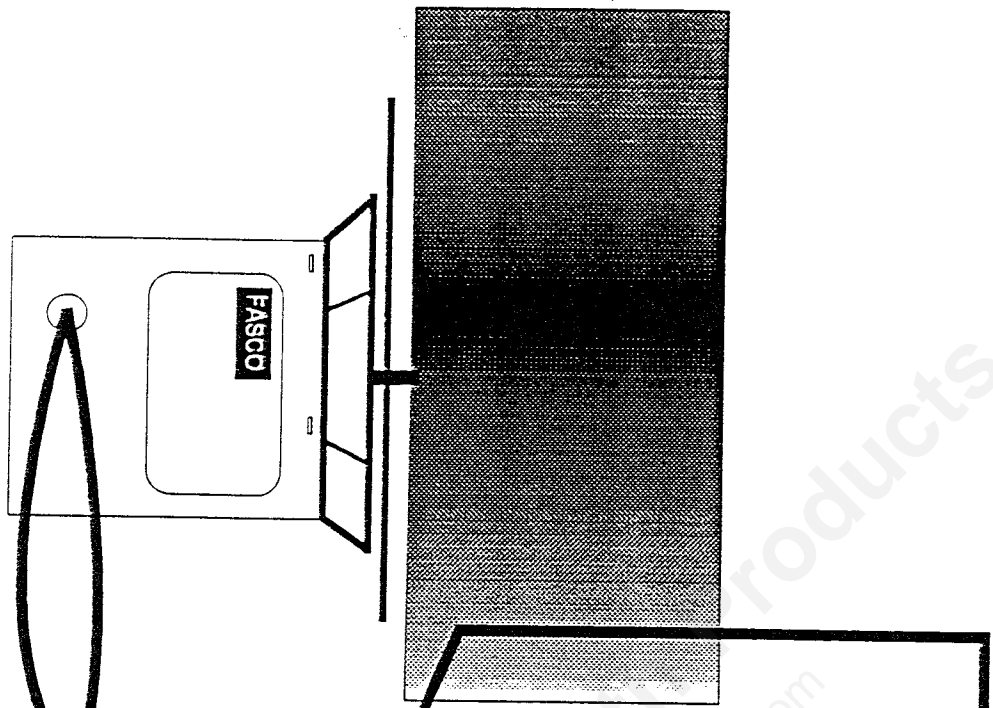

WHEN CHECKING OHMS :

UNPLUG THE FAN FROM THE WIRE HARNESS AND INSERT PROBS AS INDICATED.

COMBUSTION FAN OHMS
18 to 20 (+/- 2 OHMS)

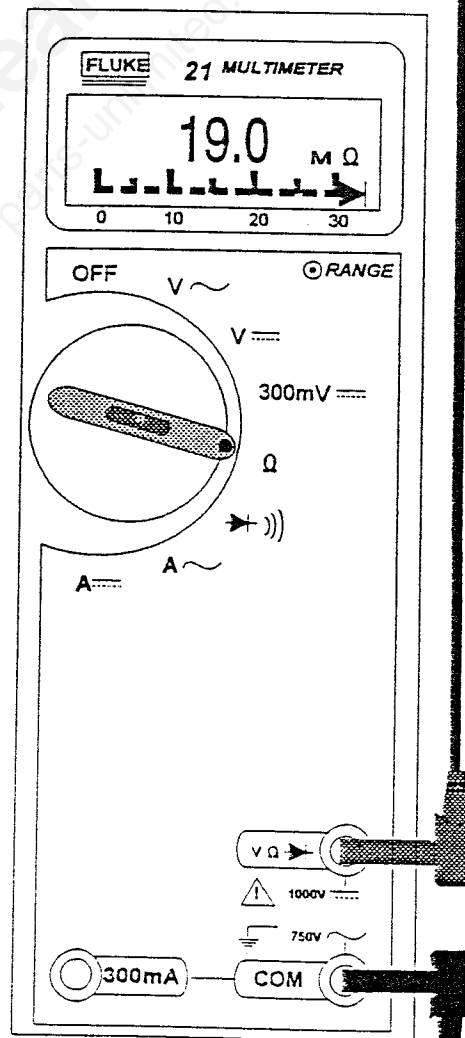

VOLTAGE READING TAKEN AS SHOWN -94'

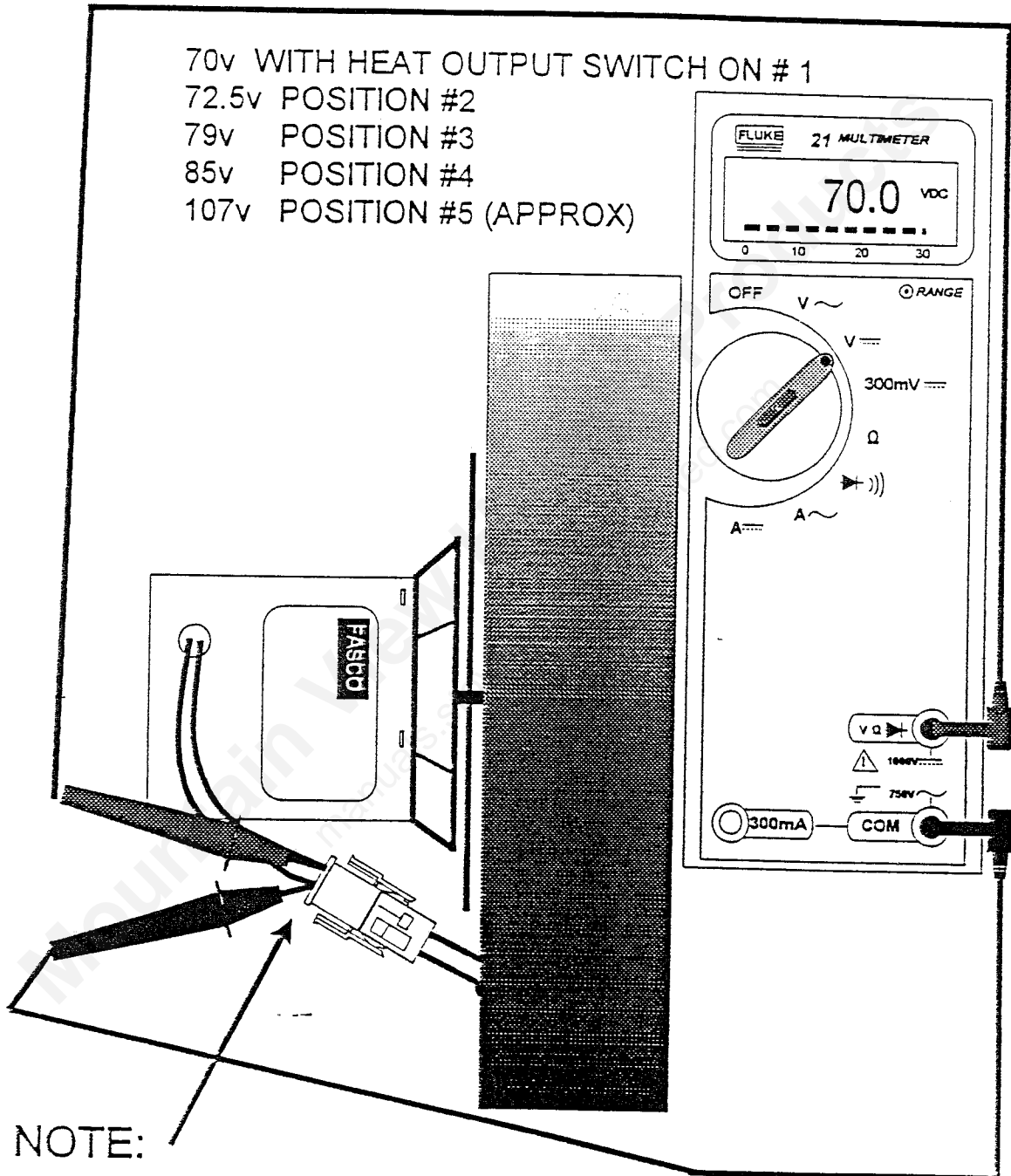

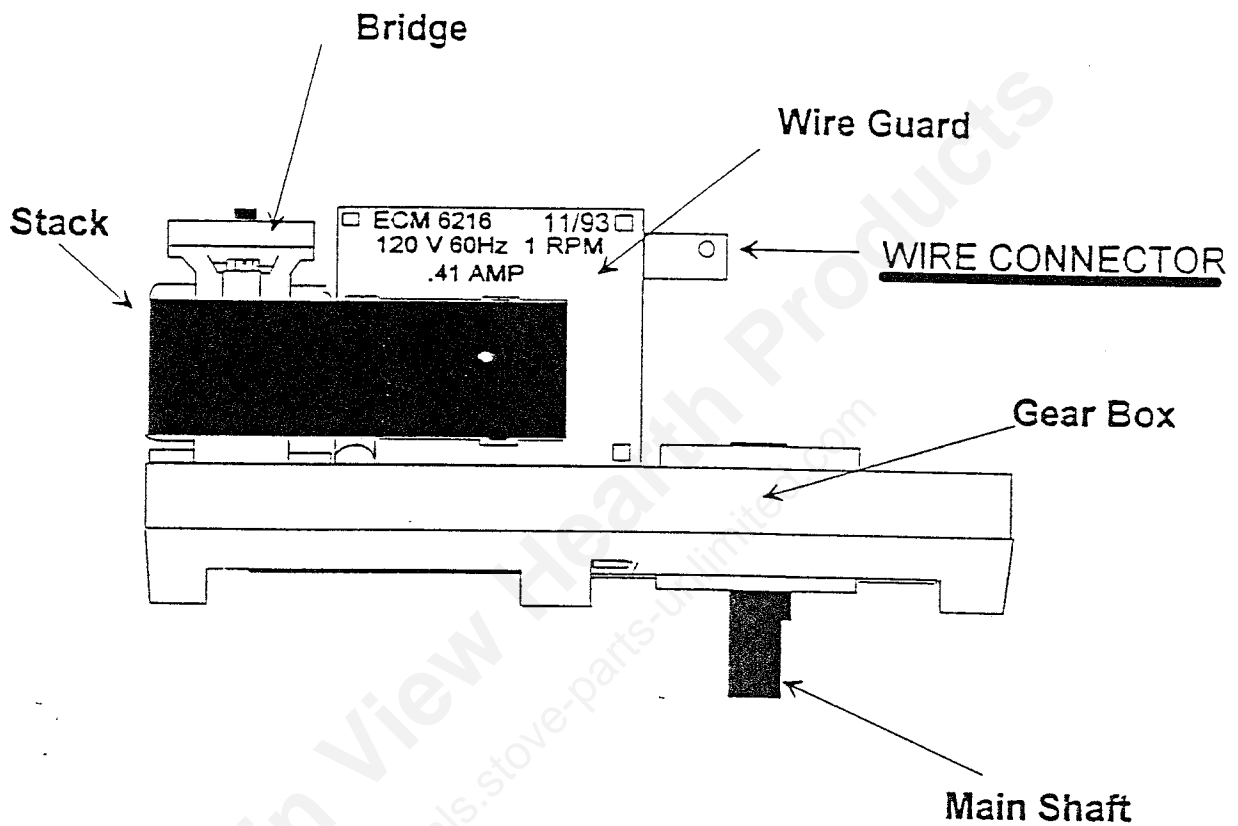

Auger Motor - PN # 12026300

ECM # 6216 (#5979 has wire leads)

.41 amps 60 Hz 120V 1 rpm

18 ohm impedance (+ / - 2 ohms)

ADVANTAGE AUGER SYSTEM CUT-A-WAY VIEW

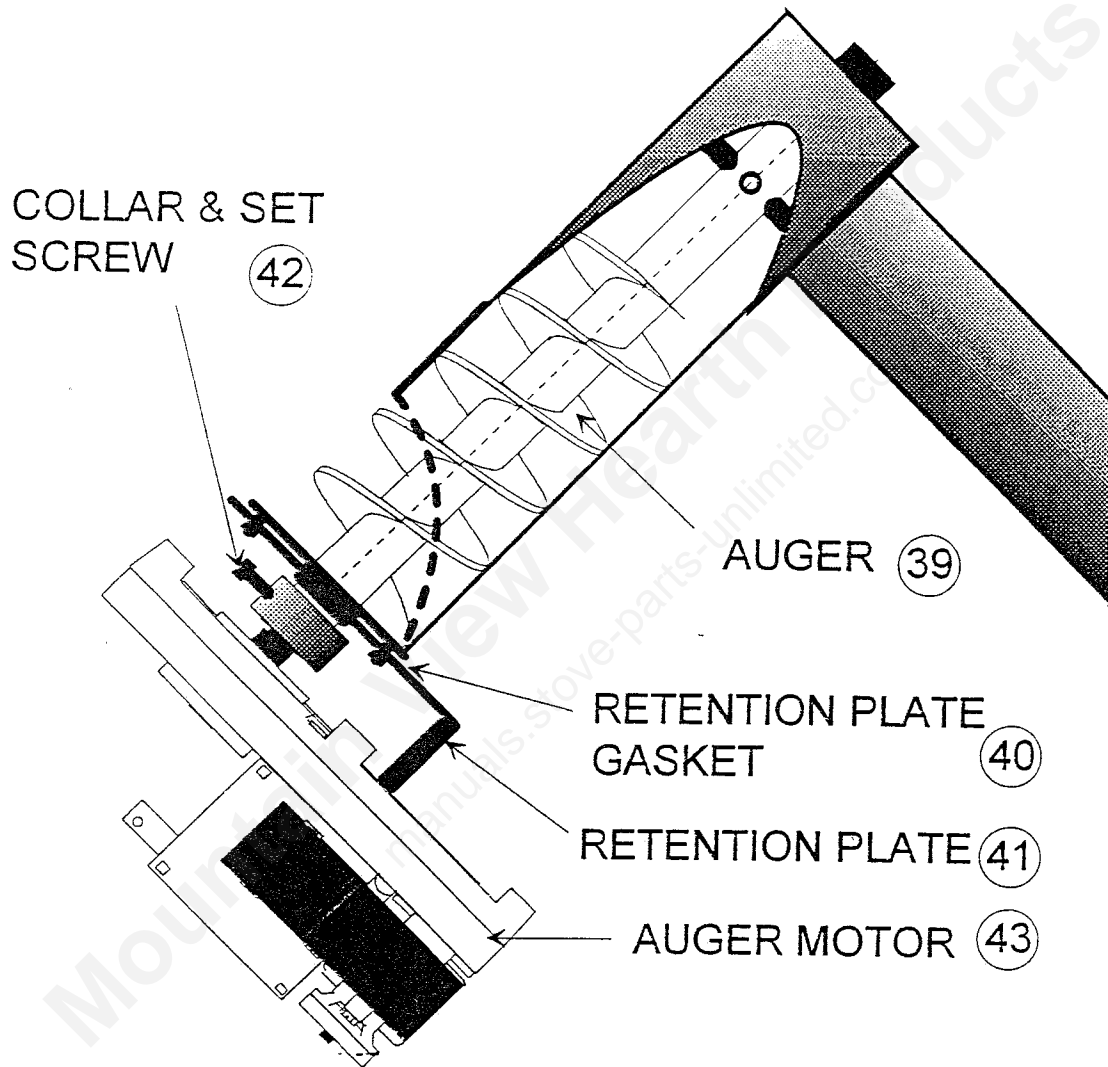

(39)	AUGER	13052100
(40)	AUGER RETENTION PLATE GASKET	61050003
(41)	AUGER RETENTION PLATE	12153900
(42)	AUGER COLLAR & SET SCREW	12041300
(43)	AUGER MOTOR	12046300

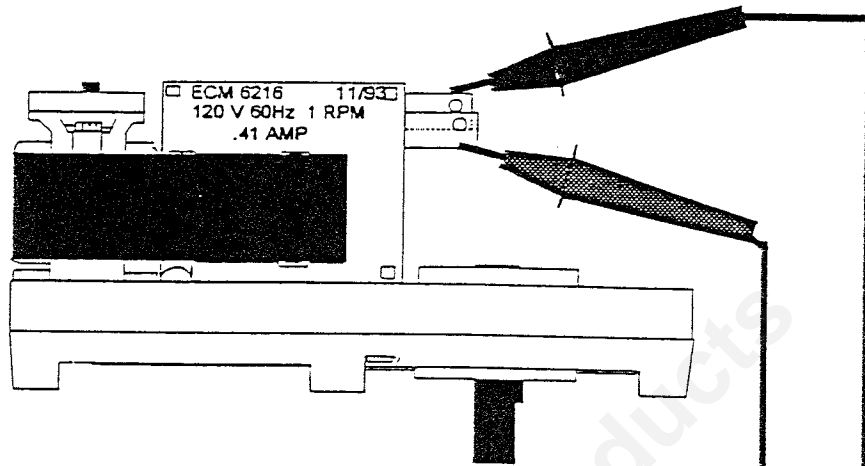

ohms read out
will show as
indicated (+/-2)

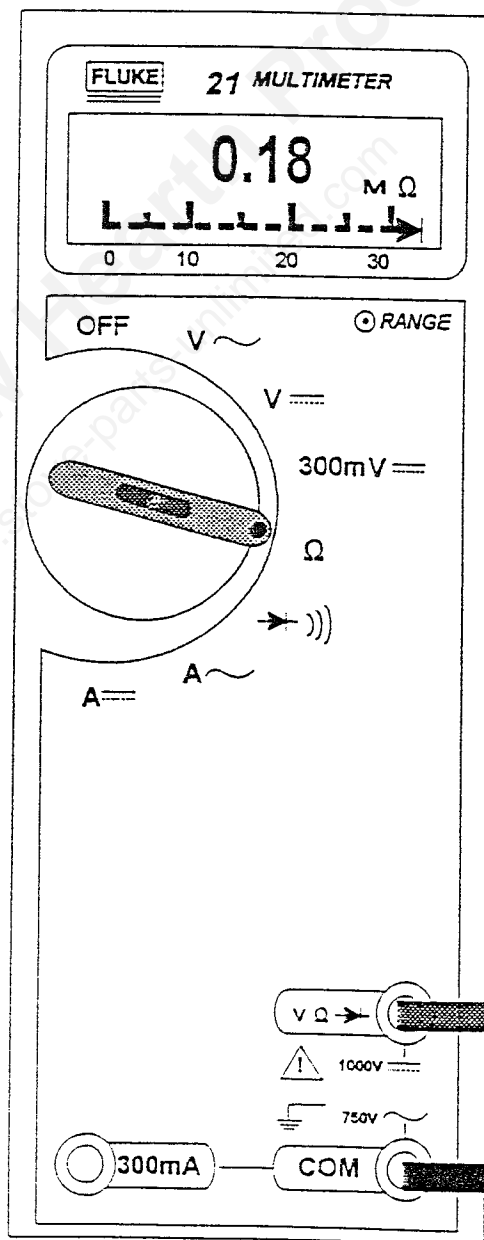

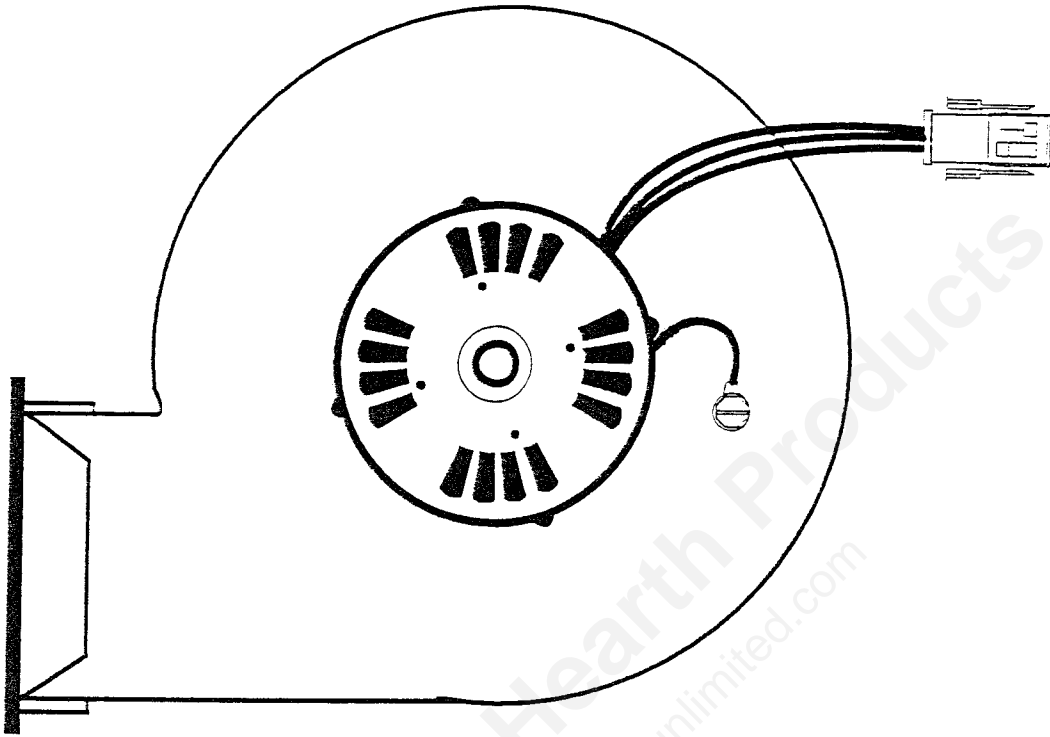

Convection Fan

PN # 12146109

FASCO # 7021-8786

Thermally Protected

1500 to 3000 RPM nominal

80cfm free air

1.25 amps 60 Hz 115 V

VOLTAGE READING TAKEN AS SHOWN

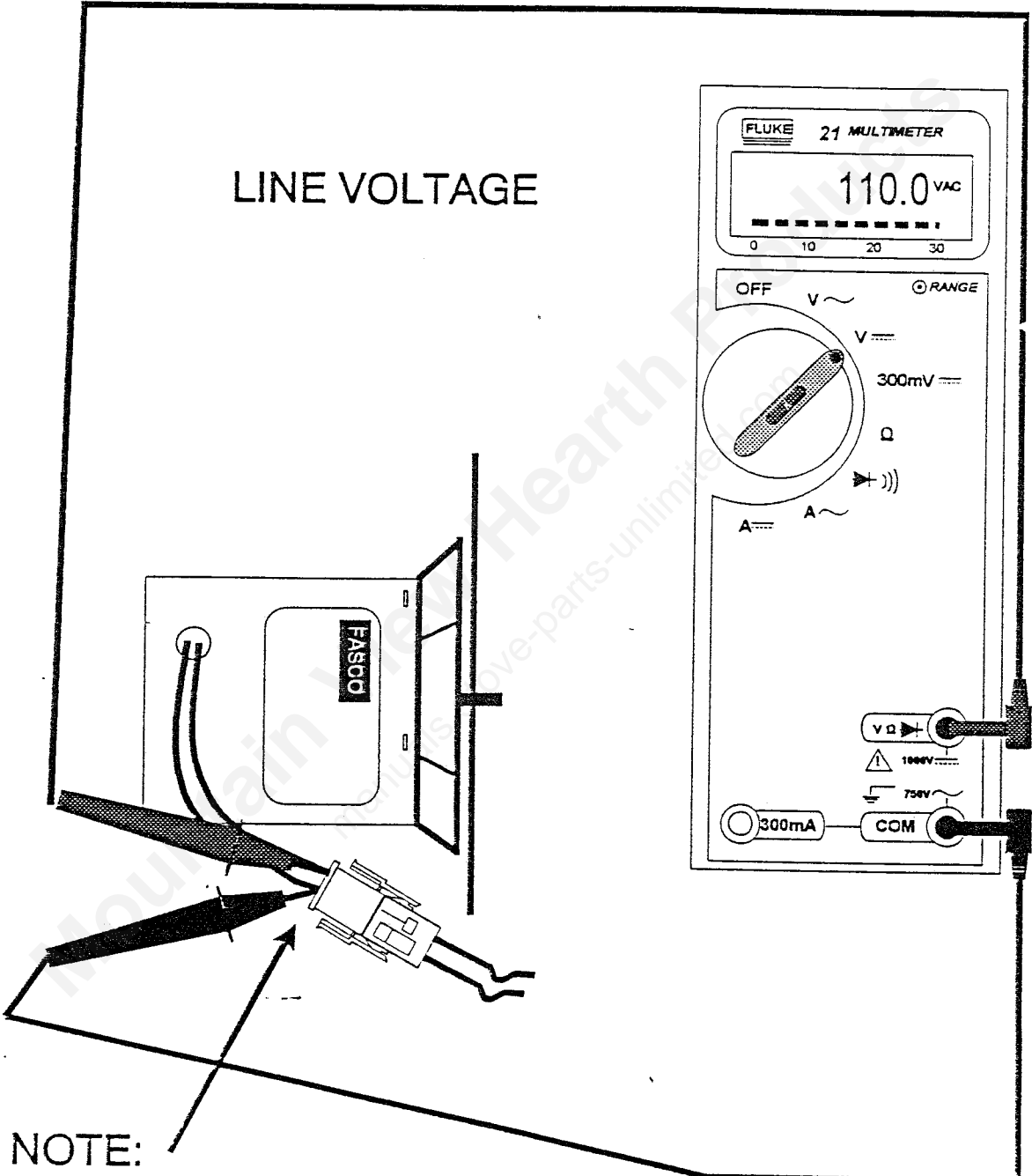

NOTE:
INSERT METER PROBS FROM THE MOTOR SIDE OF THE PLUG!
(YOU DO NOT NEED TO UNPLUG FROM THE WIRE HARNESS)

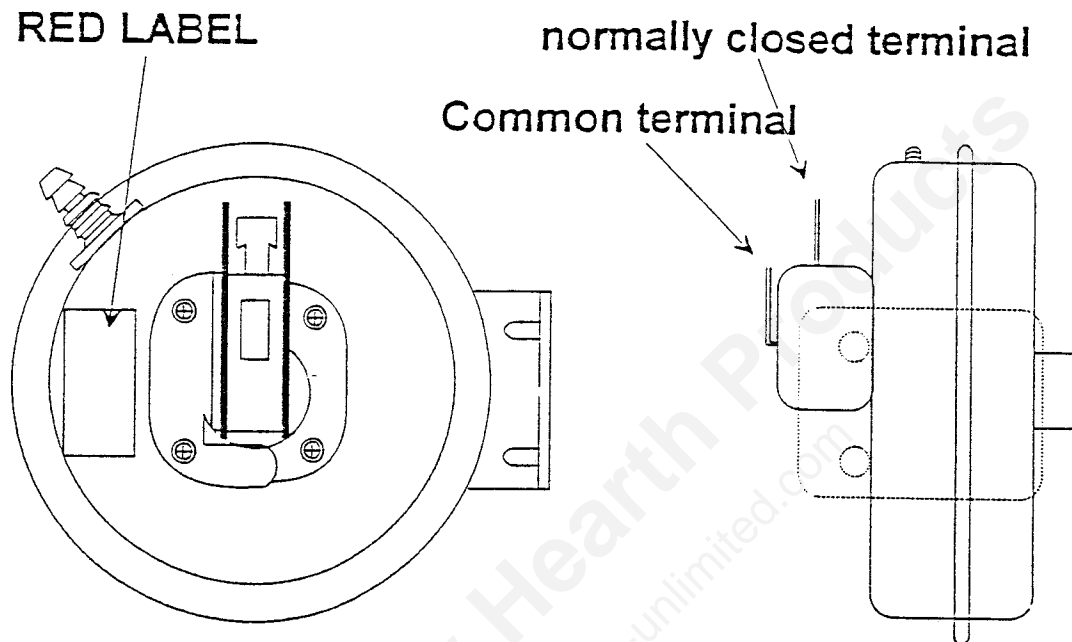

POSITIVE PRESSURE SWITCH - PN# 12125903

RED LABEL

SN# 18145 and up

ELECTRICAL SWITCH: Single pole, normally closed, snap acting contacts. Contacts change on pressure rise @ .11" +/- .04" W.C.

OPERATING TEMPERATURE RANGE :
- 40 TO 190 degree F

Normally closed switch will read as indicated

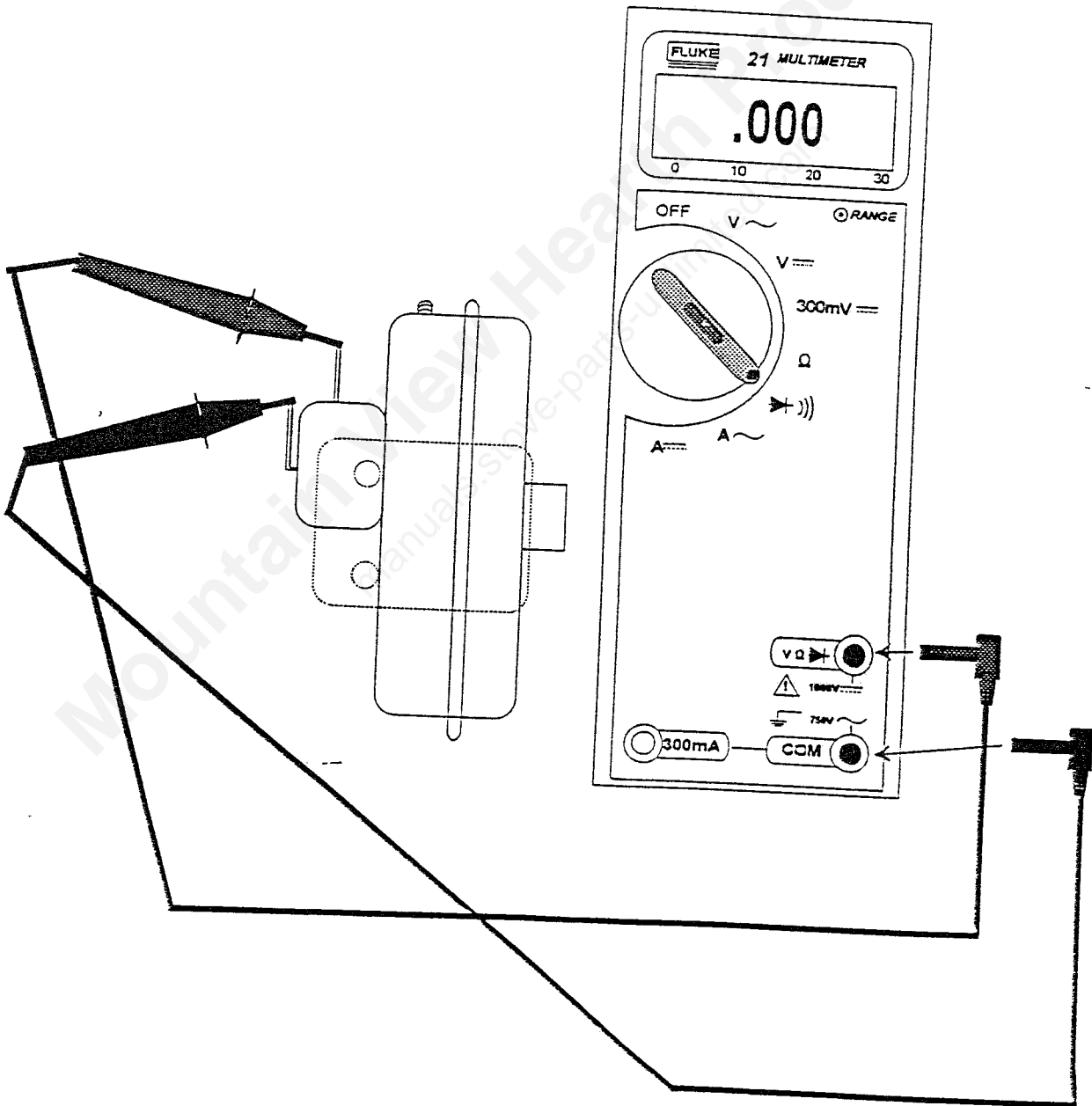

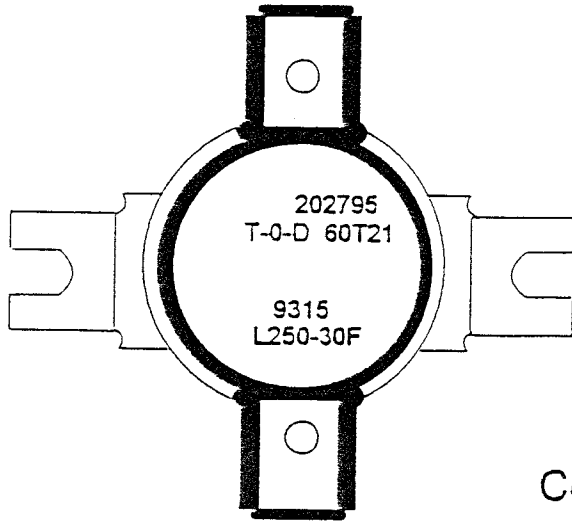

HIGH LIMIT SNAP SWITCH

PN # 12127705

TWO PER STOVE

Connected to the REAR RH firebox
and the air inlet tube.

NOTE: THE SNAP SWITCH CONNECTED TO THE REAR Righthand FIREBOX, IS THE HIGH LIMIT PROTECTION SWITCH. IF THE TEMPERATURE RISES ABOVE 250 degees F IN THE TRANSDUCT, THE NORMALLY CLOSED SWITCH WILL OPEN. THIS CUTS ALL POWER TO THE STOVE.

THE SNAP SWITCH LOCATED IN THE AIR INLET TUBE IS NORMALLY CLOSED AND WILL OPEN IF TEMPERATURES RISE ABOVE 250 degees F. THIS WILL CUT POWER TO THE AUGER MOTOR ONLY.

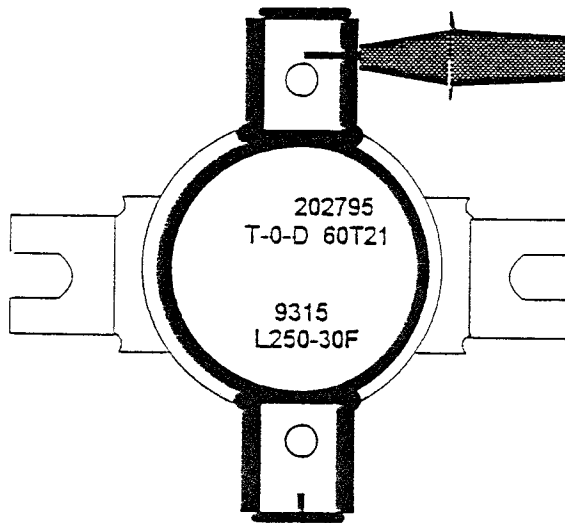

THE NORMALLY CLOSED SWITCH WILL SHOW AS INDICATED.

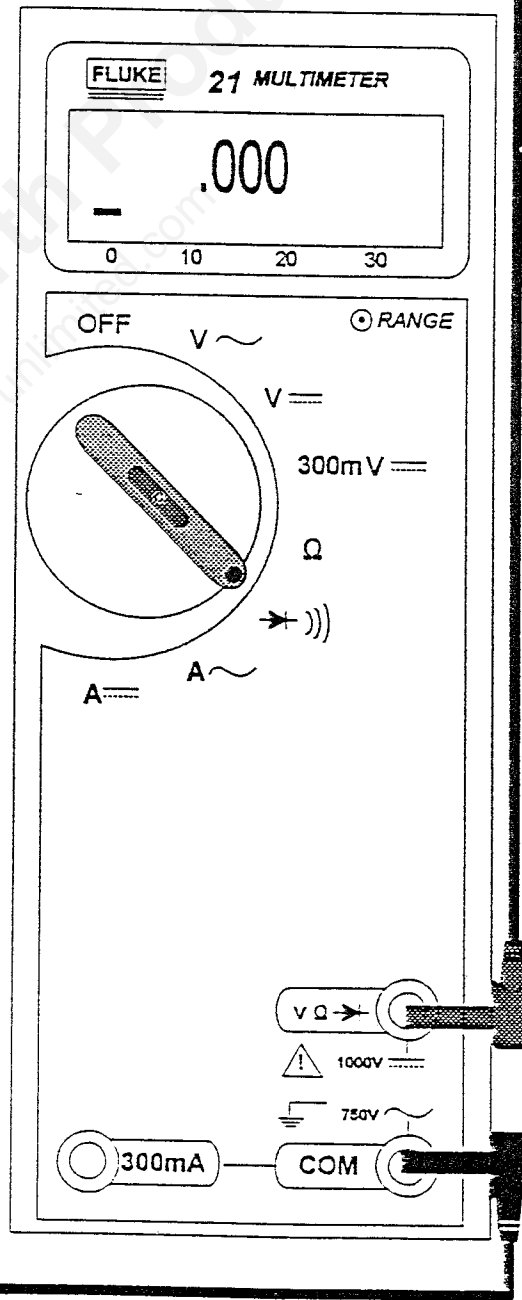

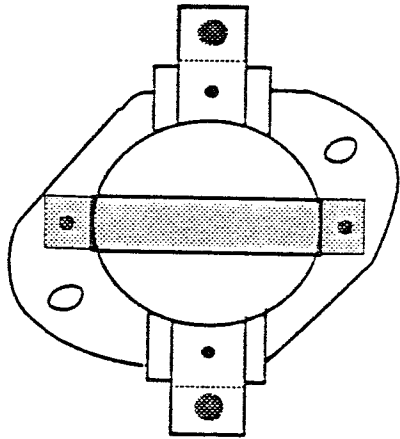

LOW LIMIT SNAP SWITCH

PN # 12057601 (CERAMIC)

LOCATED ON THE COMBUSTION FAN
IF EXHAUST TEMPERATURES EXCEED
140 degrees F, THE SWITCH CLOSSES.

THE SWITCH REMAINS CLOSED UNTIL
EXHAUST TEMPERATURES DROP BELOW
120 degrees F.

NOTE:

TWO WAYS THIS SWITCH FAILS:

STUCK CLOSED = POWER TO UNIT IS ALWAYS
ON. THE STOVE MUST BE UNPLUGGED TO SHUT
IT OFF.

STUCK OPEN = THE STOVE WILL SHUT OFF WITHIN
30 MIN. FROM START UP.

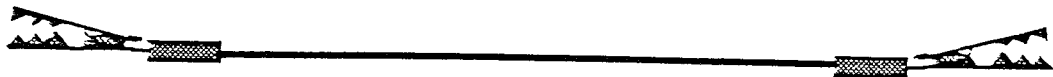

(SAMPLE JUMPER WIRE USED TO BY PASS)

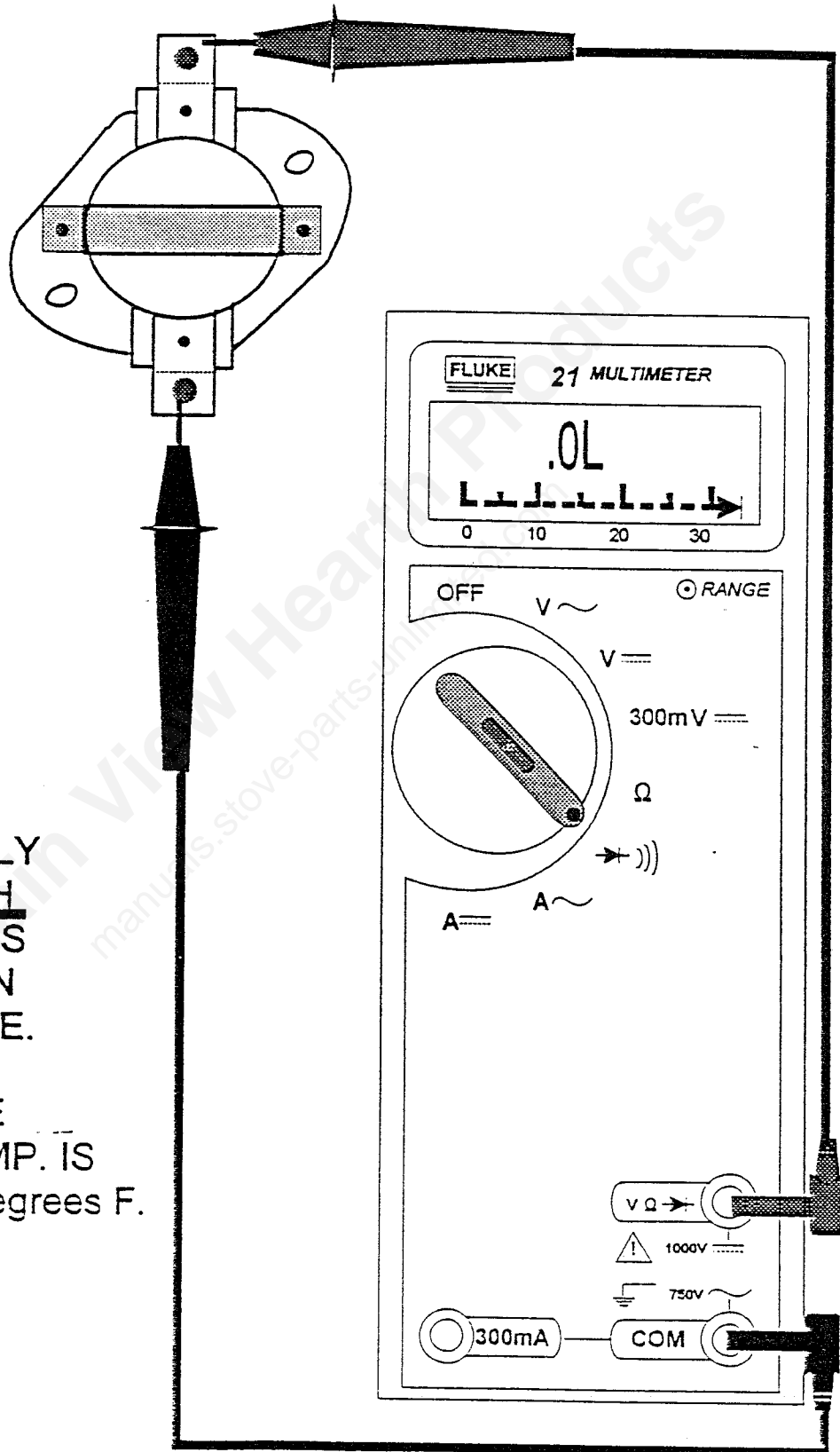

THE NORMALLY
OPEN SWITCH
 WILL SHOW AS
 INDICATED ON
 A COLD STOVE.

MEANING THE
 EXHAUST TEMP. IS
 BELOW 140 degrees F.

QUICK DISCONNECT PN 12051500

1. Apply RTV on the outside of the exhaust port of the combustion fan and slip Part "A" over the exhaust port.
 2. Using four (4) TEK screws , attach part "A".
- NOTE: Insure that one edge of the flange is horizontal
3. Apply RTV on the outside of part "B" and slip inside the PLVent Pipe. NOTE THE POSITION OF FLANGE! THE STUDS MUST LINE UP WITH PART "B" FLANGE HOLES.
 4. Using four (4) TEK screws, attach part "B".
 5. Place the Lytherm Gasket over the four studs on Part "A".
 6. Slide the stove to the PL Vent pipe. Fasten the flanges together using the four (4) lock nuts provided.

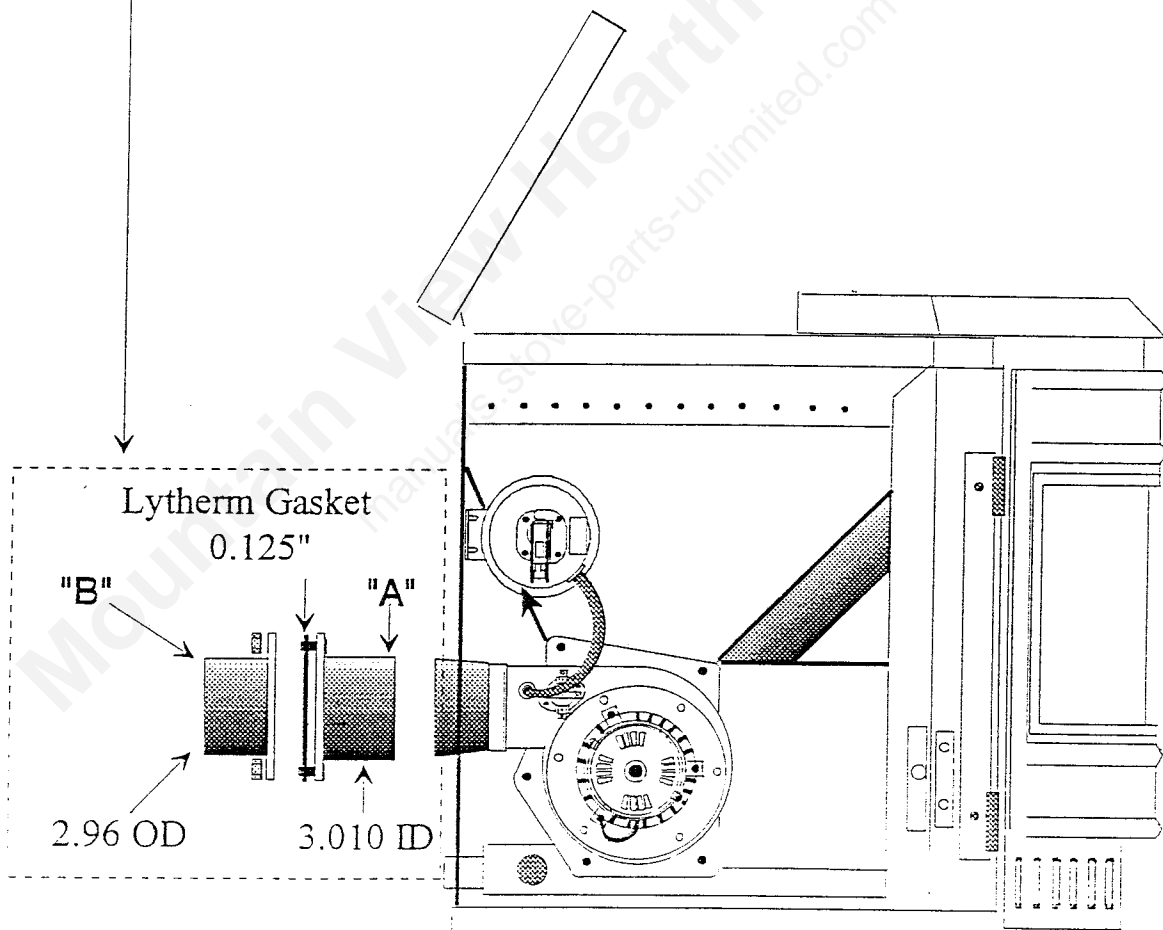

INST: PN 60020050

ASH TRAP BAFFLE EXPLODED VIEW

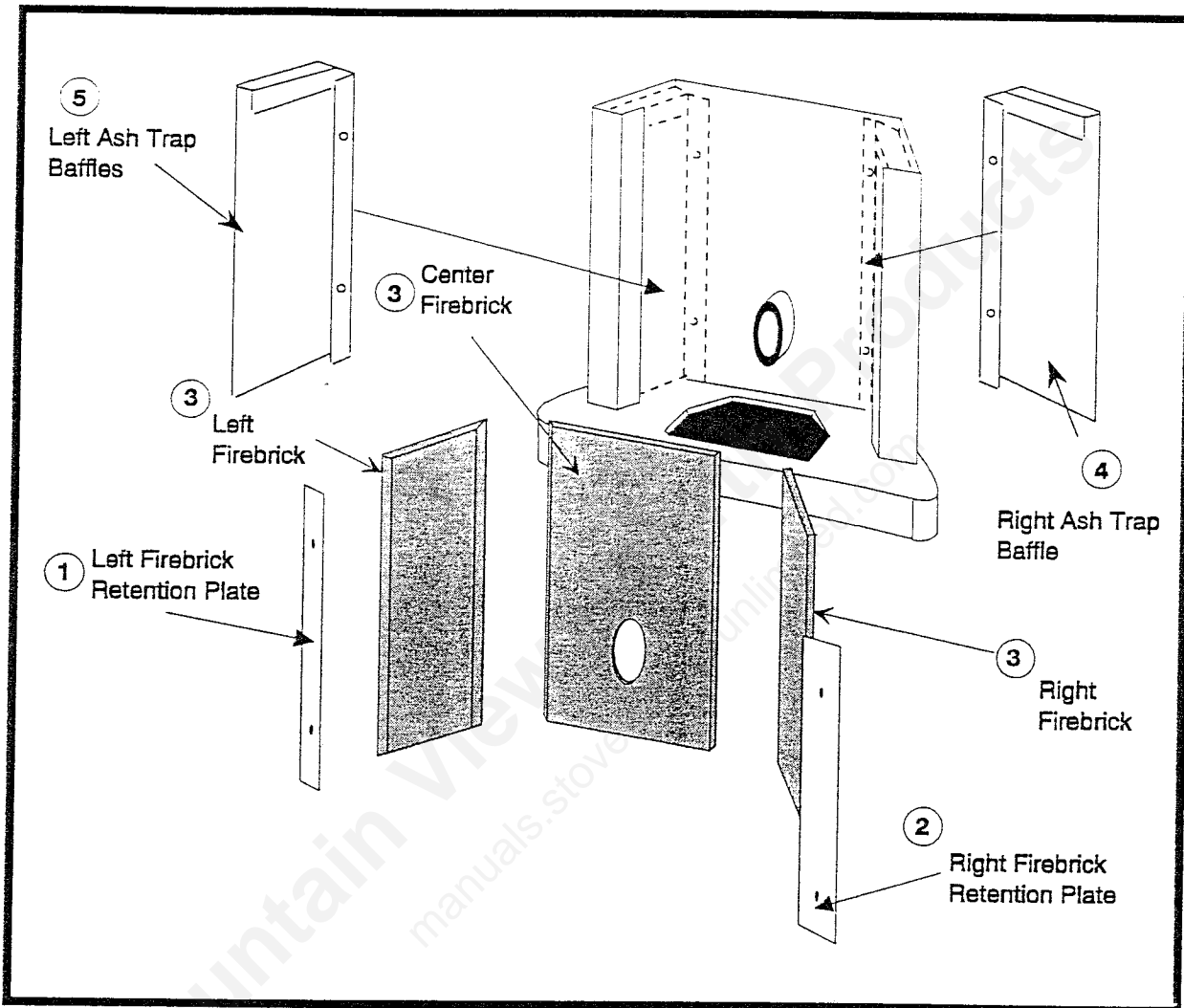

**VALID FOR SERIAL NUMBERS
#1001 TO #7107 &
#17626 TO #75863**

ITEM #	Description	Part #
①	Left Firebrick Retention Plate	12100101
②	Right Firebrick Retention Plate	12100102
③	Firebrick Panel Kit	12146500 (all three pieces in one set)
④	Right Ash Trap Baffle	12151902
⑤	Left Ash Trap Baffle	12151900

M

'94 ASH TRAP BAFFLE EXPLODED VIEW

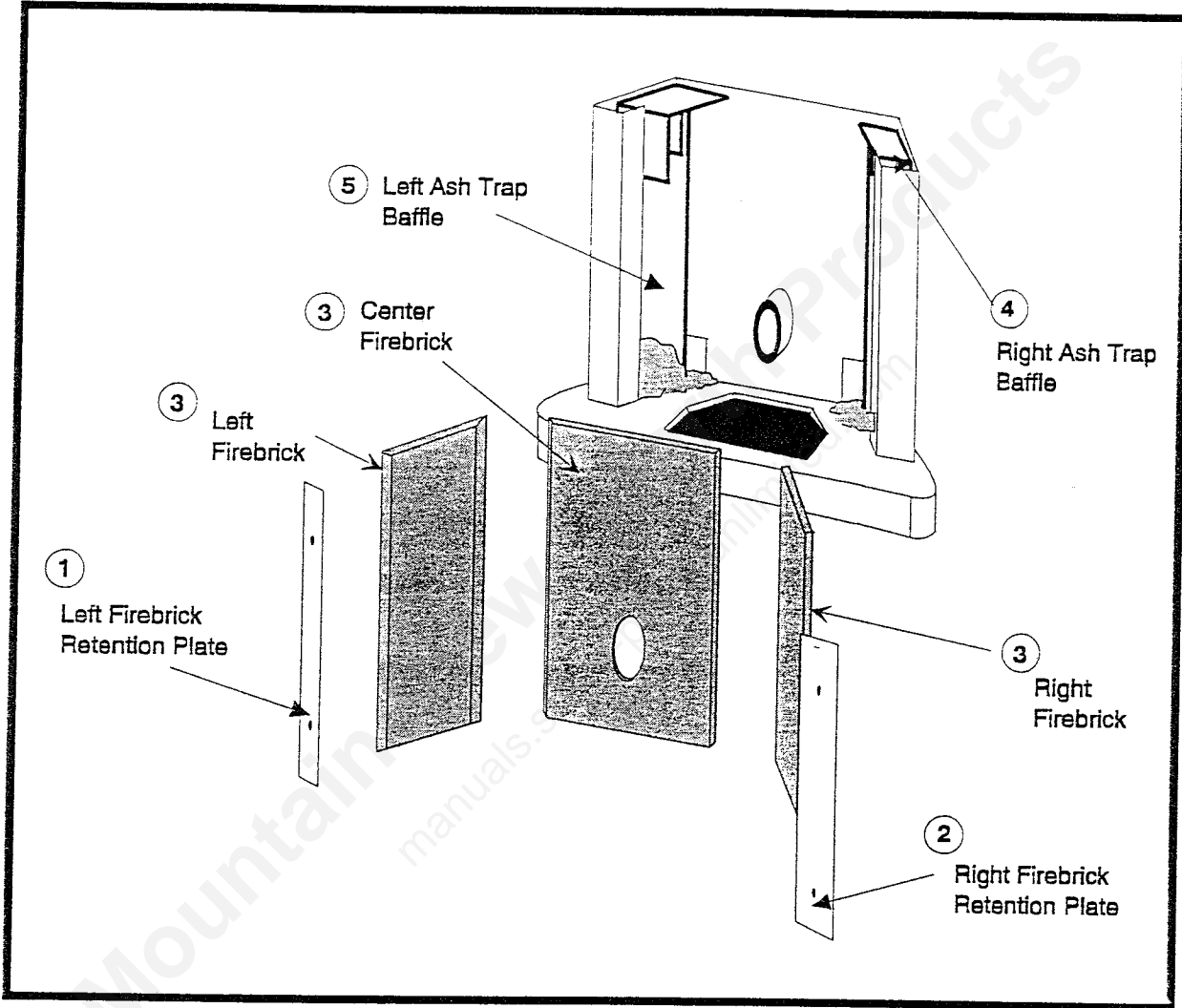

VALID FOR SERIAL NUMBERS AFTER #75864

ITEM #	Description	Part #
①	Left Firebrick Retention Plate	12100101
②	Right Firebrick Retention Plate	12100102
③	Firebrick Panel Kit	12146500 (all three pieces in one set)
④	Right Ash Trap Baffle	} 12141920 (comes as kit)
⑤	Left Ash Trap Baffle	

FASTFIRE IGNITOR TROUBLE SHOOTING

Mountain View Hearth Products
manuals.stove-parts-unlimited.com

Whitfield

FAST FIRE!

Optional Self Igniter

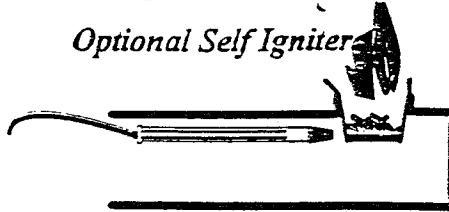

SEQUENCE OF OPERATION

Press the Start Switch

- The Combustion fan will start
- The Convection fan will start
- The Fast Fire relay will be activated

→ Slide the Auger On switch to the on position

- The Auger motor will start
- Pellets will fall into the grate

→ Within ten minutes

- Ignition will occur

→ Within 15 minutes

- Fast Fire relay will shut off

FASTFIRE TROUBLE SHOOTING

1. The probe does not heat up, does not get Red in color, indicating no power.

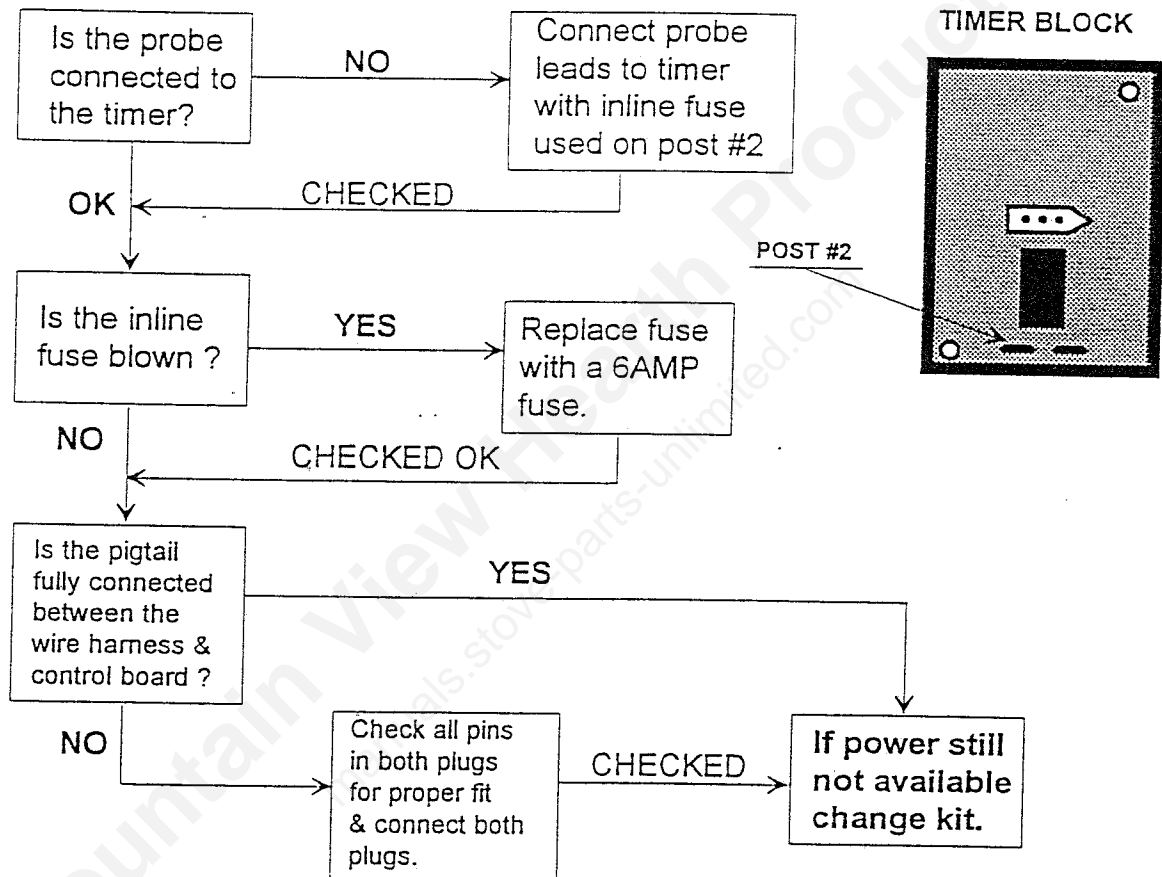

TIMER BLOCK

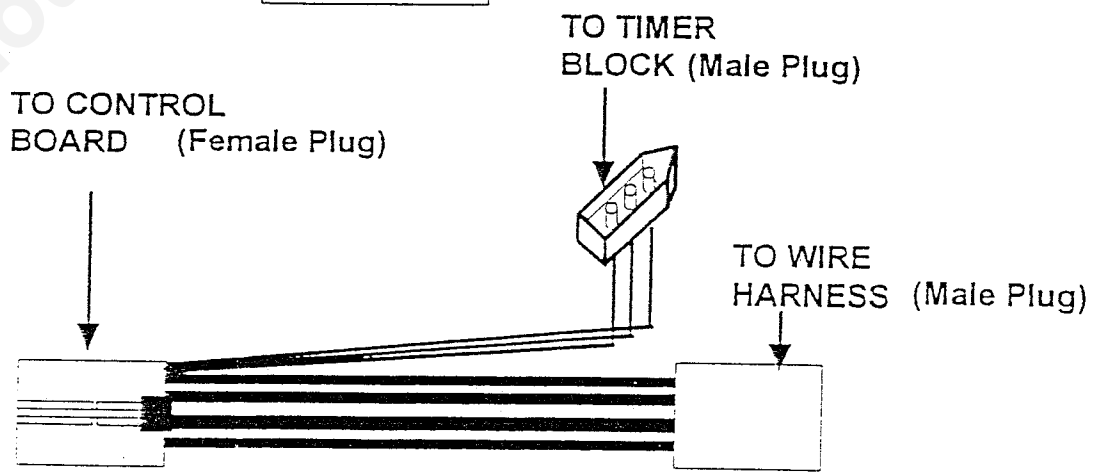
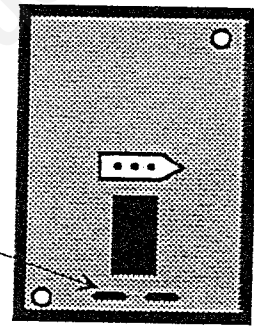

PIG TAIL WIRE HOOKUP

FASTFIRE TROUBLE SHOOTING

2. The probe does heat up, (Red in color), but fails to ignite the pellets in the 15 minutes of the "Timer" run.

