



**FREESTANDING
AND INSERT
PELLET FIRED
STOVES**



www.nficertified.org

We suggest that our pellet hearth products be installed and serviced by professionals who are certified in the U.S. by the National Fireplace Institute® (NFI) as NFI Pellet Specialists or who are certified in Canada by Wood Energy Technical Training (WETT).



**RETAIN THESE
INSTRUCTIONS
FOR FUTURE
REFERENCE**



INSTALLATION AND OPERATION MANUAL



**Freestanding Model
Advantage® Optima™ 2 FS ***



**Freestanding Model
Advantage® Optima™ 3 FS ***

Insert Model, Advantage Optima™ 3 INS not shown
* Shown with Decorative Log Option

These appliances must be properly installed and operated in order to prevent the possibility of a house fire. Please read this entire owner's manual before installing and using your pellet stove. Failure to follow these instructions could result in property damage, bodily injury or even death. Contact your local building or fire officials to obtain a permit and information on any installation requirements and inspection requirements in your area.

P/N 775097M, Rev. E, 12/03

IMPORTANT WARNINGS

CAUTION: Read this manual thoroughly before starting installation. For your safety, follow the installation, operation and maintenance instructions exactly without deviation. Failure to follow these instructions may result in a possible fire hazard and will void the warranty. If this appliance is not properly installed, a house fire may result. Contact local building or fire officials about requirements and installation inspection in your area.

1. **DO NOT CONNECT THIS UNIT TO A CHIMNEY FLUE CONNECTED TO ANOTHER APPLIANCE.**
2. Do not connect this appliance to air ducts or any air distribution system.
3. Do not install a flue damper in the exhaust venting system of this appliance.
4. Do not use class B venting intended for gas appliances as a chimney or connector pipe on a pellet fired appliance.
5. The minimum clearances must be maintained for all combustible surfaces and materials including; furniture, carpet, drapes, clothing, wood, papers, etc. Do not store firewood within this clearance space.
6. **INSTALLATION DISCLAIMER** - This stoves exhaust system works with negative combustion chamber pressure and a slightly positive chimney pressure. Therefore, it is imperative that the exhaust system be gas tight and installed correctly. Since Lennox Hearth Products has no control over the installation of your stove, Lennox Hearth Products grants no warranty, implied or stated for the installation or maintenance of your stove, and assumes no responsibility for any consequential damage(s).
7. Burning any kind of fuel consumes oxygen. If outside air is not ducted to the appliance, ensure that there is an adequate source of fresh air available to the room where the appliance is installed.
8. The stove will not operate using natural draft, nor without a power source for the blower and fuel feeding systems.
9. Never use gasoline, gasoline-type lantern fuel, kerosene, charcoal lighter fluid, or similar liquids to start or "freshen up" a fire in this heater. Keep all such liquids well away from the heater while it is in use.
10. **CONTINUOUS OPERATION:** When operated correctly, this appliance cannot be overfired. Continuous operation at a maximum burn can, however, shorten the life of the electrical components (blowers, motors, and electronic controls), and is not recommended. Typical approved operation would include running at the low to mid range setting with occasional running on the maximum setting during the coldest periods of the winter. The blower speed control should be turned to high when operating the stove on the high heat setting.
11. **CAUTION: NEVER PUT FINGERS NEAR AUGER.** Pellet fuel is fed to the UltraGrate™ by a screw auger. This auger is driven by a high torque motor. The auger is capable of doing serious harm to fingers. Keep pellets in the hopper at all times and keep fingers away from auger. The auger can start and stop automatically at any time while the stove is running.
12. **CAUTION: HOT WHILE IN OPERATION.** An appliance hot enough to warm your home can severely burn anyone touching it. Keep children, clothing and furniture away. Contact may cause skin burns. Do not let children touch the appliance. Train them to stay a safe distance from the unit.
13. **APPROVED FUEL:** This appliance is designed specifically for use only with pelletized wood fuels only. With its advanced UltraGrate™ technology, this appliance is designed and approved for the burning of wood residue pellets with up to 3% ash content. This appliance is NOT approved to burn cardboard, nut hulls, cherry pits, corn, etc. regardless if it is in pellet form. Failure to comply with this restriction will void all warranties and the safety listing of the stove. Consult with your authorized Lennox Hearth Products dealer for more information on approved pellet fuels.
14. **FLYASH BUILD-UP:** For all wood pellet fuel-burning heaters, the combustion gases will contain small particles of fly ash. This will vary due to the ash content of the fuel being burned. Over time, the fly ash will collect in the exhaust venting system and restrict the flow of the flue gases. The exhaust venting system should be inspected regularly and cleaned as necessary.
15. **SOOT FORMATION:** Incomplete combustion can occur during startup, shutdown, or incorrect operation of the room heater. This can lead to some soot collecting in the exhaust venting system. A precautionary inspection on a regular basis is advisable to determine the necessity of cleaning. The exhaust venting system should be inspected regularly and cleaned as necessary.
16. **DISPOSING OF ASHES:** Any ashes removed from the pellet stove must be deposited in a metal container with a tight-fitting lid. The closed container of ashes should be placed on a noncombustible floor or on the ground, well away from all combustible materials, outside of the dwelling pending final disposal. If the ashes are disposed of by burial in soil or otherwise locally dispersed, they should be retained in the closed container until all cinders have been thoroughly cooled.
17. **SAVE THESE INSTRUCTIONS.**
18. See the listing label on the appliance (or see *Safety / Listing Labels* on pages 51 and 52).

TABLE OF CONTENTS

Important Warnings	2
Testing / Listing, EPA, Using this Manual.....	3
Planning Your Installation	4-9
Manufactured (Mobile) Home Installation	9
Installation	10-21
Care and Operation	22-27
Routine Maintenance.....	28-33
Specifications.....	34-36
Definitions	37
Wiring Diagram	38
Troubleshooting	39-41
Replacement Parts List / Diagrams	42-47
Optional Accessories	48
Installation Tips	49
Simple Operating Instructions.....	50
Safety / Listing Label and EPA Label	51-52
Ownership Records	53

LISTING / TESTING

Listing: The listing laboratory is ITS (Intertek Testing Services) and the listing mark is Warnock Hersey.

Testing: In accordance with the specifications and procedures listed in UL 1482 & ASTM E1509 for solid fuel room heater, this appliance has been independently tested to UL, ULC and CSA standards, report # 6658 for Advantage® Optima 2 and report #476-1244 for Advantage® Optima 3. UL 1482 states requirements for installations as a free-standing room heater, or hearth insert for masonry or listed factory built (zero clearance) fireplaces. The safety-listing label is located on an inside hopper surface of the pellet stove. Please read this safety label carefully. It contains important information about installation and operation of this appliance. This appliance is tested and listed for residential installation according to current national and local building codes as:

- A Freestanding Room Heater
- A Manufactured (mobile) Home Heater

EPA (Environmental Protection Agency)

Status: EPA Exempt - Pellet appliances that are designed with the combustion air supply exceeding the 35 to 1 (by weight) ratio are exempt from EPA regulations and are “non-affected facilities.”

PRODUCT IS SUBJECT TO CHANGE WITHOUT NOTICE.

CONGRATULATIONS ON THE PURCHASE OF YOUR NEW PELLET STOVE MANUFACTURED BY LENNOX HEARTH PRODUCTS.

When you purchased your new pellet stove, you joined the ranks of thousands of concerned individuals whose answer to their home heating needs reflects their concern for aesthetics, efficiency and our environment. We extend our continued support to help you achieve the maximum benefit and enjoyment available from your new pellet stove.

It is our goal at Lennox Hearth Products to provide you, our valued customer, with an appliance that will ensure you years of trouble free warmth and pleasure.

Thank you for selecting a Lennox Hearth Products stove as the answer to your home heating needs.

Sincerely,
All of us at Lennox Hearth Products

PACKAGING LIST

The assembled pellet stove model Optima 2 FS, Optima 3 FS and Optima 3 INS are packaged with an accessory package, which contains the following:

- One - Installation and operation instructions manual.
- One - Warranty.
- One - Power cord.
- One- Control board – Optima 3 INS only.
- One - Screw, #8 x 1/2” tek (for mounting control board) – Optima 3 INS only.
- One - Grate scraper.
- One - Video
- One - Lower trim
- One - Wall thermostat.
- One - Roll of thermostat wire.
- Two- Leveling bolts, 1/4-20 x 3” – Optima 3 INS only.
- One - Door Handle (removable)
- One - Fireplace Warning Label (see page 8)

Surround Kit (For Optima 3 INS Only)

(Purchased separately, see page 48) kit is packaged with:

- One - Top surround panel.
- One - Left surround panel.
- One - Right surround panel with door.
- One - Left side trim.
- One - Right side trim.
- One - Top trim.
- Two - Corner keys (“L” shaped surround trim brackets).

USING THIS MANUAL

Please read and carefully follow all of the instructions found in this manual. Please pay special attention to the safety instructions provided in this manual. The homeowner’s *Care and Operation Instructions* included here will assure you have many years of dependable and enjoyable service from your appliance.

PLANNING YOUR INSTALLATION

QUESTIONS TO ASK LOCAL BUILDING OFFICIAL

A correct installation is critical and imperative for reducing fire hazards and perilous conditions that can arise when wood pellet burning appliances are improperly installed. The installer must follow all of the manufacturers' instructions.

The installation of this appliance must conform to local codes and applicable state and federal requirements. Familiarity with these requirements before installation is essential. Important considerations to discuss with local building officials include:

1. Applicable codes (i.e. Uniform Mechanical Code, State or Regional Codes)?

Electrical codes:

In USA, NEC, ANSI / NFPA 70-2002.

In Canada, CSA C22.1

Power Supply Requirements – The power cord must be plugged into a standard, 115 volt, 60 Hz grounded electrical outlet. The approximate power requirement is 362 Watts, and will peak up to 736 Watts for approximately 6 minutes when the self-igniter is operating (it will turn off 2 minutes after flame detection). The power cord must be routed to avoid contact with any of the hot or sharp exterior surface areas of the stove. When installed into a manufactured (mobile) home, the appliance must be electrically grounded to the steel chassis (see page 9, *Manufactured [Mobile] Home Requirements*). These requirements must be met unless otherwise specified by state or local authorities.

WARNING: ELECTRICAL GROUNDING INSTRUCTIONS: THIS APPLIANCE IS EQUIPPED WITH A THREE-PRONG (GROUNDING) PLUG FOR YOUR PROTECTION AGAINST SHOCK HAZARD AND SHOULD BE PLUGGED DIRECTLY INTO A PROPERLY GROUNDED THREE-PRONG RECEPTACLE. DO NOT CUT OR REMOVE THE GROUNDING PRONG FROM THIS PLUG. DO NOT ROUTE POWER CORD UNDER OR IN FRONT OF APPLIANCE.

2. Local amendments?
3. Is a permit required - cost?
(you may wish to contact your insurance company to ask if they require this).
4. Is outside combustion air required?
5. Rooms where the installation is not allowed?

INSTALLATION / MAINTENANCE STANDARDS

National Fire Protection Association – The primary NFPA standard that refers to installation and maintenance of pellet appliances and venting is NFPA 211: Chimneys, Fireplaces, Vents, and Solid Fuel appliances, Jan. 2000.

SELECTING A LOCATION

The design of your home and where you place your stove will determine its value as a source of heat. This type of appliance depends primarily on air circulation (convection) to disperse its heat, and therefore, a central location is often best. There are other practical considerations, which must be considered before a final selection of locations is made.

- ◆ Existing Chimneys
- ◆ Pellet Fuel Storage
- ◆ Aesthetic Considerations
- ◆ Roof Design (rafter locations & roof pitch)
- ◆ Room Traffic
- ◆ Proximity to Combustibles
- ◆ Electrical Wiring

The installation of this stove will require some research. Once your options are determined, consult with your local building department who will be able to give you the necessary installation requirements for your area (Is a building permit required? Rooms where installation may not be allowed, etc.).

WARNING: CHECK ALL LOCAL BUILDING AND SAFETY CODES BEFORE INSTALLATION. THE INSTALLATION INSTRUCTIONS AND APPROPRIATE CODE REQUIREMENTS MUST BE FOLLOWED EXACTLY AND WITHOUT COMPROMISE. ALTERATIONS TO THE STOVE ARE NOT ALLOWED. DO NOT CONNECT THE STOVE TO A CHIMNEY SYSTEM SERVING ANOTHER STOVE, APPLIANCE, OR ANY AIR DISTRIBUTION DUCT. FAILURE TO FOLLOW THESE INSTRUCTIONS WILL VOID THE MANUFACTURERS WARRANTY.

SMOKE DETECTORS

Since there are always several potential sources of fire in any home, we recommend installing smoke detectors. If possible, install the smoke detector in a hallway adjacent to the room (to reduce the possibility of occasional false activation from the heat produced by the stove). If your local code requires a smoke detector be installed within the same room, you must follow the requirements of your local code. Check with your local building department for requirements in your area.

PLANNING YOUR INSTALLATION

FLOOR PROTECTION - Optima 2 FS

This appliance requires noncombustible floor protection. If the floor protection is to be stone, tile, brick, etc., it must be mortared or grouted to form a continuous non-combustible surface. If a chimney connector extends horizontally over the floor, the protection must cover the floor under the connector and at least 2" to either side.

A noncombustible floor protector must fully cover the area beneath the appliance and extend 6" to the front, 6" to the sides, and up to 6" from the back as illustrated on this page.

***Note: When installed at clearances less than 6", floor protection is only required to extend to the wall.**

Top View of Model: Optima 2 FS

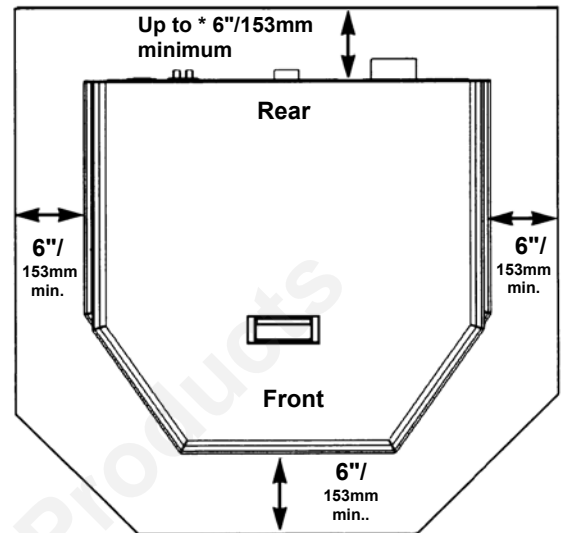

PLANNING YOUR INSTALLATION

FLOOR PROTECTION - Optima 3 FS

The floor protector must meet or exceed the minimum thermal requirements as defined on this page (see *Floor Protection/Hearth Extension Using Alternate Material As Floor Protector*). If the floor protection is to be stone, tile, brick, etc., it must be mortared or grouted to form a continuous noncombustible surface. If a chimney connector extends horizontally over the floor, protection must also cover the floor under the connector and at least 2" (51 mm) to either side.

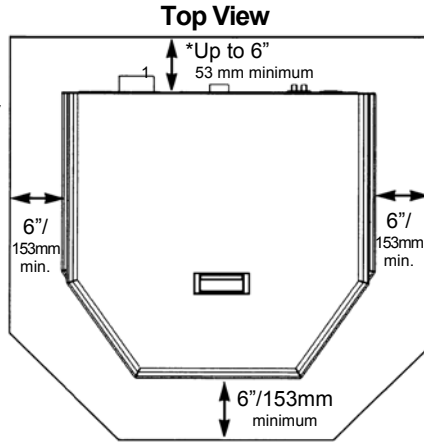

The floor protector must fully cover the area beneath the appliance and extend 6" to the front, 6" to the sides, and 6" from the back as shown in the illustration to the right (Note: When installed at clearances less than 6", the floor protection is only required to extend to the wall).

FLOOR PROTECTION / HEARTH EXTENSION USING ALTERNATE MATERIAL AS FLOOR PROTECTOR (also see *Floor Protection* above for freestanding models and *Hearth Requirements*, page 8 for the insert model)

The hearth pad or alternate material used as a floor/hearth protector must be constructed of a durable noncombustible material having an equal or better thermal conductivity value (lower k value) of $k = .84 \text{ BTU} / \text{IN FT}^2 \text{ HR } ^\circ\text{F}$ or a thermal resistance that equals or exceeds $r = 1.19 \text{ HR } ^\circ\text{F FT}^2 \text{ IN/BTU}$ with a minimum thickness of 3/8". With these values, determine the minimum thickness of the alternate material required using the formula(s) and the table shown here (see chart - *Approved Alternate Materials for Floor/Hearth Protection*).

Note: Any noncombustible material having a minimum thickness of 3/8" (10 mm) whose k value is less than .84 or whose r value is more than 1.19 is acceptable. If the alternate material used has a higher k value or lower r value will require a greater thickness of the material used. In some cases, if the k value is less or the r value higher, a thinner material may be used.

Methods of determining floor protection equivalents:

To determine the thickness required for the alternate material when either the k value or r value is known, use either the k formula or r formula:

Example: Durock™ Cement is to be used for the floor protection. How thick must this material be? The following formulas give the means of determining minimum thickness required.

T_M = minimum thickness required for alternate material
k_M = k value per inch of alternate material
T_L = minimum thickness of listed material
r_M = r value per inch of alternate material

Using the k formula:

$$\text{Minimum thickness of alternate material} = \frac{\text{k-value (per Inch) of alternate material}}{\text{k-value (per inch) of listed material}} \times \text{Specified min. thickness of listed material}$$

$$T_M \text{ (inches)} = \frac{k_M}{.84} \times T_L$$

$$T_M \text{ (inches)} = \frac{1.92}{.84} \times .375 \text{ (3/8")}$$

Answer using k: $2.29 \times 0.375 = 0.858 = \sim 7/8"$
7/8" thickness (minimum) Durock™ Cement will be required.

Using the r formula:

$$T_M \text{ (inches)} = \frac{1.19}{r_M} \times T_L$$

$$T_M \text{ (inches)} = \frac{1.19}{.52} \times 375 \text{ (3/8")}$$

Answer using r: $2.29 \times 0.375 = 0.858 = \sim 7/8"$
7/8" thickness (minimum) Durock™ Cement will be required.

At times it is important to know what combination of materials are acceptable for use as floor protection. The "R values" are used to determine acceptable combinations of materials because "R values" are additive where r and k values are not.

$$\text{"R value"} = \frac{1}{k} = r \times \text{thickness of material used}$$

Example: Given that the required "R value" for a suitable floor protector used must be equal to or greater than "R" = $r \times T_L = 1.19 \times .375 = .45$.

Listed Material

	Thermal Values		Specified Minimum Thickness
	k (per inch)	r (per inch)	T_L
Listed Material →	.84	1.19	3/8" (.375)

Approved Alternate Materials for Floor/Hearth Protection (**)

Alternative Materials ↓	Thermal Values		* Minimum Thickness
	k (per inch)	r (per inch)	T_M
Kaowool M Board	.47	2.13	* 3/8"
Micore 160™	.35	2.86	* 3/8"
Micore 300™	.46	2.18	* 3/8"
Durock™ Cement	1.92	.52	7/8"
Hardibacker™	1.95	.51	7/8"
Hardibacker 500™	2.30	.44	1 1/8"
Cultered Stone Hearthstone™	2.82	.35	1 5/8"
Wonderboard	3.23	0.31	1 1/2"
Face brick	9.00	0.11	4 1/8"
Common brick	5.00	0.20	2 1/4"
Cement mortar	5.00	0.20	2 1/4"
Ceramic tile	12.5	.08	5 5/8"
Marble	~20.0	~.05	9"

Note: To convert inches to millimeters divide by .03937.

* After minimum thickness is calculated, the thickness can be no less than 3/8" (.375" / 10mm).

(**) If the floor protector to be used is a noncombustible material and is NOT listed on the chart above, the manufacturer of the material must provide either the listed k-value per inch or r-value per inch and the minimum acceptable thickness will need to be calculated per instructions on this page.

PLANNING YOUR INSTALLATION

Clearances to combustibles are determined from testing to applicable standards for allowable heat transfer. The clearances allowed as shown here, do not take into account operation or serviceability requirements.

CLEARANCES

Optima 2 FS and Optima 3 FS - Standard residential or manufactured (mobile) home installation. These appliances require the following minimum clearances to combustibles:

MINIMUM CLEARANCES TO COMBUSTIBLES

Optima 2 FS	Manufactured (Mobile) Home or Residential Installation	
	Horizontal Flue – Directly Through Wall inch / millimeter	Interior Vertical Flue inch / millimeter
A - Sidewall to unit	◆4" / 102 mm	◆4" / 102 mm
B – Backwall to unit	*2" / 51 mm	9" / 229 mm
C – Sidewall to unit Corner	*2" / 51 mm	*2" / 51 mm
D – Max. Depth of Alcove	●24" / 610 mm	●24" / 610 mm
E – Flue to Wall	3" / 77 mm	3" / 77 mm
◆ Measured to fuel hopper lid in alcove. ● Minimum Alcove Measurements - Height 48" / 1220 mm Width 31" / 788 mm		

Optima 3 FS	Manufactured (Mobile) Home or Residential Installation	
	Horizontal Flue – Directly Through Wall inch / millimeter	Interior Vertical Flue inch / millimeter
A - Sidewall to unit	◆6" / 153 mm	◆6" / 153 mm
B – Backwall to unit	*2" / 51 mm	9" / 229 mm
C – Sidewall to unit Corner	*2" / 51 mm	*2" / 51 mm
D – Max. Depth of Alcove	●16" / 407 mm	●16" / 407 mm
E – Flue to Wall	3" / 77 mm	3" / 77 mm
◆ Measured to fuel hopper in alcove. ● Minimum alcove measurements - Height 48" / 1220 mm Width 38" / 966 mm		

- Minimum clearances specified may not allow for ease of operation and maintenance (please take this in to account when planning the installation). If installed to the minimum clearances, removal of the appliance may be necessary for servicing.
- Recommended clearance zone from the front of the appliance to combustibles is 4 feet minimum.

* The certified back wall clearance as shown on the listing label is 1" (see Safety / Listing Label) but for proper hopper lid operation in corner and parallel installations a 2" clearance is required.

Rear Wall or Alcove – Optima 2 FS and Optima 3 FS

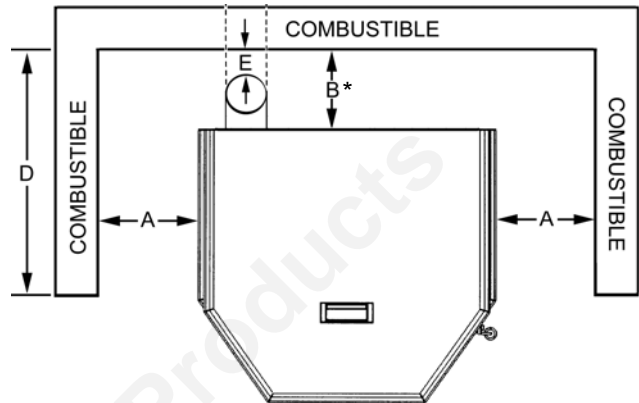

Corner - Optima 2 FS

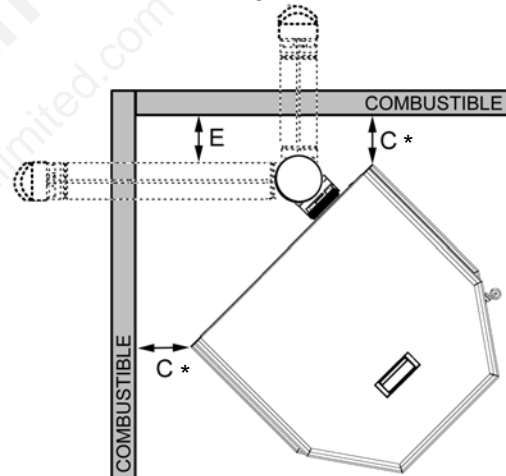

Corner - Optima 3 FS

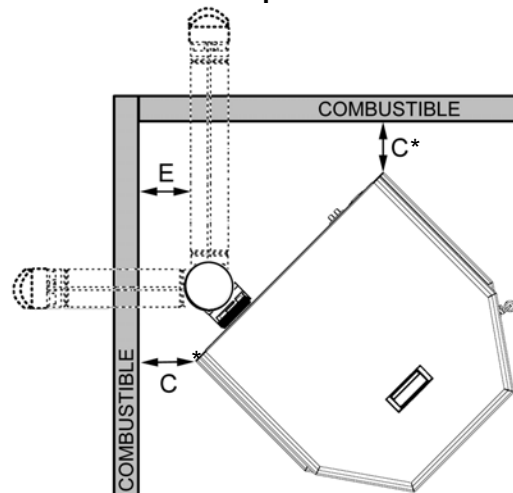

PLANNING YOUR INSTALLATION

MASONRY AND FACTORY BUILT FIREPLACES

The model Optima 3 INS is approved for installation into a solid fuel burning fireplace, either a masonry fireplace (built to UBC 37 or ULC S628 standards) or an approved factory-built / zero clearance fireplace (built to UL 127 or ULC S610 standards). See pages 20 and 21 for additional information on venting.

Minimum Fireplace Firebox Size

Height	20 1/8" / 512 mm
Width @ Front (extends back 1 1/2")	32" / 814 mm
Width @ back	24 5/8" / 626 mm
Depth	17 3/4" / 452 mm

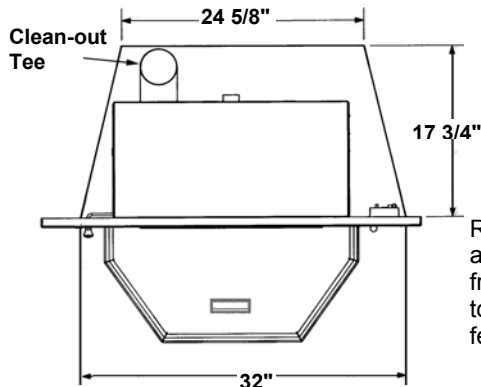

Recommended clearance zone from the front of the appliance to combustibles is 4 feet minimum.

CAUTION: The fireplace in which the Optima 3 INS is to be installed must be thoroughly cleaned if it has been used to burn wood or synthetic logs. Have the chimney and all inside surfaces of the fireplace brushed and vacuumed so that no soot, embers, or loose combustion deposits can be drawn into the heat circulation blower and blown into the living area. If any portion of the chimney system shows signs of structural or mechanical weaknesses, such as: cracks, leaky joints, corroded or warped surfaces, the faulty portion must be repaired or replaced prior to installing this appliance.

IMPORTANT: When installing the Optima 3 INS into a factory built fireplace or heatform, the air flow within and around the fireplace shall not be altered by the installation of the insert (i.e. DO NOT BLOCK louvers or cooling air inlet or outlet ports, circulating air chambers in a steel fireplace liner or metal heat circulator). The factory built firebox must accept the insert without modification other than removing bolted or screwed together pieces such as smoke shelf / deflectors, ash lips, screen or door tracks and damper assemblies. Any fireplace component, which is removed, must be retained so they can be reinstalled to restore the fireplace to its original operating condition. The removal of any part must not alter the integrity of the outer shell of the pre-engineered fireplace cabinet in any way. A Warning Label (provided with appliance) must be installed in the fireplace firebox so that it shall be visible upon removal of the fireplace insert (see *Fireplace Warning Label*, below). Use RTV high Temperature Silicone as an adhesive to affix the warning label.

Fireplace Warning Label
(provided in accessory package)

THIS FIREPLACE HAS BEEN ALTERED TO ACCOMMODATE A **FIREPLACE INSERT** AND SHOULD BE INSPECTED BY A QUALIFIED PERSON PRIOR TO REUSE AS A CONVENTIONAL FIREPLACE.

HEARTH / FLOOR PROTECTION - Optima 3 INS

The area directly in front of the Optima 3 INS must be protected by a noncombustible material or a fireplace hearth or hearth extension as follows:

Combustible flooring must be protected by non-combustible material in Canada and 10 millimeter (3 / 8 inches) millboard or equivalent non-combustible in U.S. extending beneath the heater and to the front as indicated or to the nearest permitted combustible material. See page 6 for requirements when using alternate material as hearth extension.

The protected area must extend 6" to the front of the face of the Optima 3 INS.

MINIMUM CLEARANCES TO COMBUSTIBLES

	inches / millimeters
A - Insert to side wall	6" / 153 mm
B - Insert to side trim	1" / 26 mm
C - Hearth extension	6" / 153 mm
D - Insert to mantel	18" / 458 mm
E - Insert to top trim	1" / 26 mm

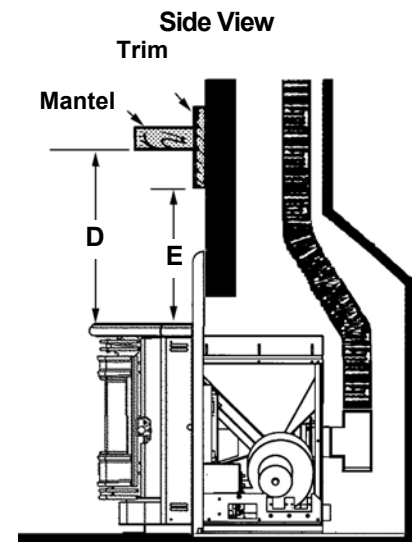
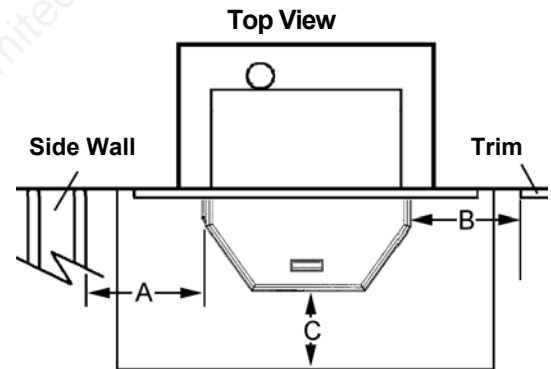

PLANNING YOUR INSTALLATION

MANUFACTURED (MOBILE) HOME INSTALLATION

Freestanding Models – Optima 2 FS and Optima 3 FS
In addition to the standard installation instructions, the following instructions may be required by local, state or federal building codes:

- Stove must be permanently bolted to the floor.
- An outside air inlet must be provided for combustion and be unrestricted while unit is in use. Use a galvanized or stainless steel pipe for the duct (the outside air inlet on the stove is 2" diameter).
- Stove must be permanently electrically grounded to the steel chassis of the home. The location selected for ground attachment to the stove must be dedicated for this purpose.
- See pages 14 through 19 for additional information on venting requirements.
- Do not install appliance in a sleeping room.
- The structural integrity of the manufactured home floor, walls, ceiling and roof must be maintained.

NOTE: The grounding of this product, at installation, must comply with NFPA-70 standards, CSA C22.1 in Canada, as well as any local codes.

MANUFACTURED (MOBILE) HOME EXHAUST VENT PIPE INSTALLATION GUIDELINES

Use only listed type "PL" pellet vent pipe. Pipe should extend at least 3 feet above the part of the roof through which it passes. The top of the pipe should be at least 2 feet above the highest required elevation of any part of the manufactured (mobile) home within 10 feet of the pipe.

If the exhaust vent exits the manufactured (mobile) home at a location other than the roof, and exits at a point 7 feet or less above the ground level on which the manufactured (mobile) home is positioned. A guard or method of enclosing the pipe shall be provided at the point of exit for a height of up to 7 feet. The openings, if any, in this guard shall not allow a 3/4" rod to pass through. A 1/2" rod could pass through but should not be able to touch the pipe when inserted through the opening a distance of 4 inches.

Models – Optima 2 FS and Optima 3 FS

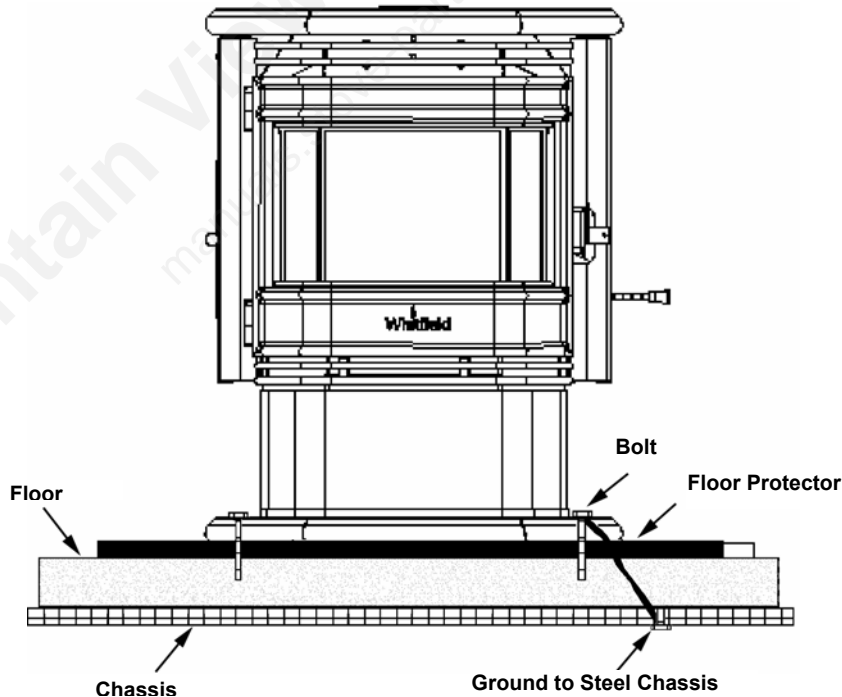

INSTALLATION

REMOVING APPLIANCE FROM PALLET

1. After removing the packaging from the stove, lift the hopper lid, and remove all pre-packaged items that were shipped in the hopper. Next, open the stove door and remove all pre-packaged items.
2. Using a socket or open end wrench (7/16" for freestanding units and 3/8" for the insert), remove the pallet bolts which secure the unit to the pallet (located on each side of back corners and at the front under ash pan). See following pictures.

Optima 3 INS

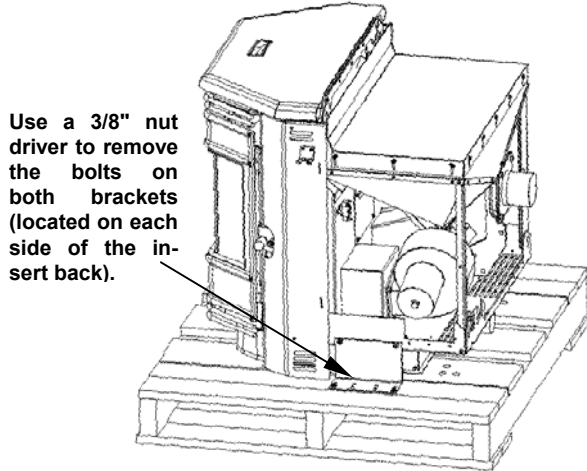

Side View of Optima 2 FS & Optima 3 FS
(Removing Back Pallet Bolts)

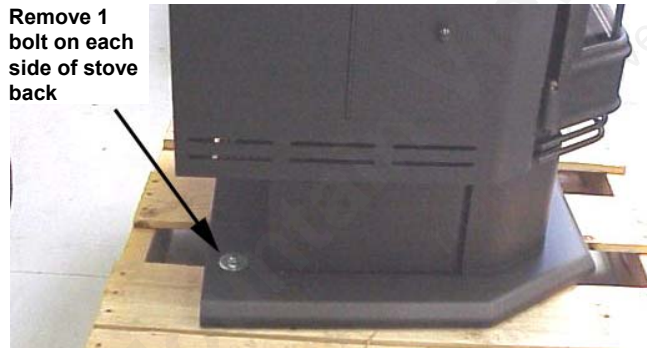

Note: The pallet bolt at the front of appliance is located under the ash pan (this will require removing the ash pan. See *Ash Pan* on pages 28 and 29 for removal instructions). See following picture (freestanding unit shown).

Front View - Removing Front Pallet Bolt

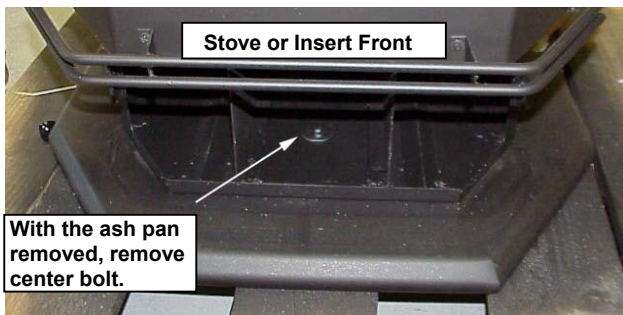

INSTALLATION CHECK LIST

It is strongly recommended that you have an authorized Lennox Hearth Products dealer install your stove. If you install your stove yourself, you should review your installation plan with an authorized Lennox Hearth Products dealer.

Check list:

Check off each item as you proceed with the installation process.

- Read the ENTIRE stove installation section first
- Read the Insert or Freestanding section (whichever applies).
- Determine the appropriate measurements and locations for your installation.
- Follow the general installation directions under Stove Installation and the installation section appropriate to your stove.
- Be sure to pre-fit all items before you install, fasten, or set up the stove permanently.

Prior to lighting your stove:

- Review the *Important Warnings* section (page 2).
- Review *Fuel Specifications* (page 27).
- Review and follow instructions in the *Care and Operation* Section (pages 22 to 27).
- Plug power cord connector into corresponding connector on the back of appliance (see illustrations on page 13 showing connector locations).

Note: Optima 3 INS – Route power cord behind side surround panel.

After you have begun operation of your stove:

- Review the routine cleaning / maintenance information.
- Enjoy the warmth from your new Lennox Hearth Products pellet stove!

(Insert Only) It is important to level the appliance. In some installations such as a recessed firebox floor (if the existing fireplace floor is lower than the hearth), install the 2 leveling bolts (1/4-20 x 3" long) into the threaded holes at the rear base of the Optima 3 INS. Adjust bolts until appliance is level.

INSTALLATION

INSTALLING SURROUND ASSEMBLY - Optima 3 INS (to be done after venting system is installed)

The surround kit (purchased separately) comes with a set of metal panels that enclose the fireplace opening when fitted together. There is also a trim assembly that frames the surround assembly to give it an attractive finished appearance. Put the surround assembly together according to the following instructions.

1. Remove panels from package.
2. Open the hopper lid on Optima 3 INS so it is out of the way for when panels are installed.
3. Install the control board onto the right side panel (with door) using the TEK screw (#8 x 1/2") provided.
4. Position the power cord so that it will be behind either the right or left side surround panel when they are installed.
5. Install right side surround panel onto right side of the Optima 3 INS body by sliding the 2 flanges on side of panel into corresponding slots on the Optima 3 INS.
6. Connect the wiring harness from the Optima 3 INS into corresponding connector on control board.

Locate damper rod on left side of the Optima 3 INS. Rotate angled arm of rod so it is pointing down. Remove damper knob and set aside.

7. Install the left-hand panel onto the left side of Optima 3 INS body by sliding the 2 flanges on side of panel into corresponding slots on the Optima 3 INS.
8. Reach behind left surround panel and rotate damper arm so that end is inserted into the upper right hand slot of left surround panel (see illustration on page 12, Optima 3 INS).
9. Reinstall damper knob by threading it onto end of damper rod.
10. Set the top surround panel in place over the two side panels. Position the 2 tabs on bottom of top surround panel so they slide into corresponding clips on the Optima 3 INS. Connect the top surround panel to the side panels by pressing pins from side panels into corresponding holes on top panel.
11. Remove the surround trim from its packaging. Assemble it together using the corner keys ("L" shaped brackets) provided. Slide assembled trim over the top surround panel and slide it down over the side panels.
12. Push the Optima 3 INS back into place so the surround is flush with the face of the hearth.

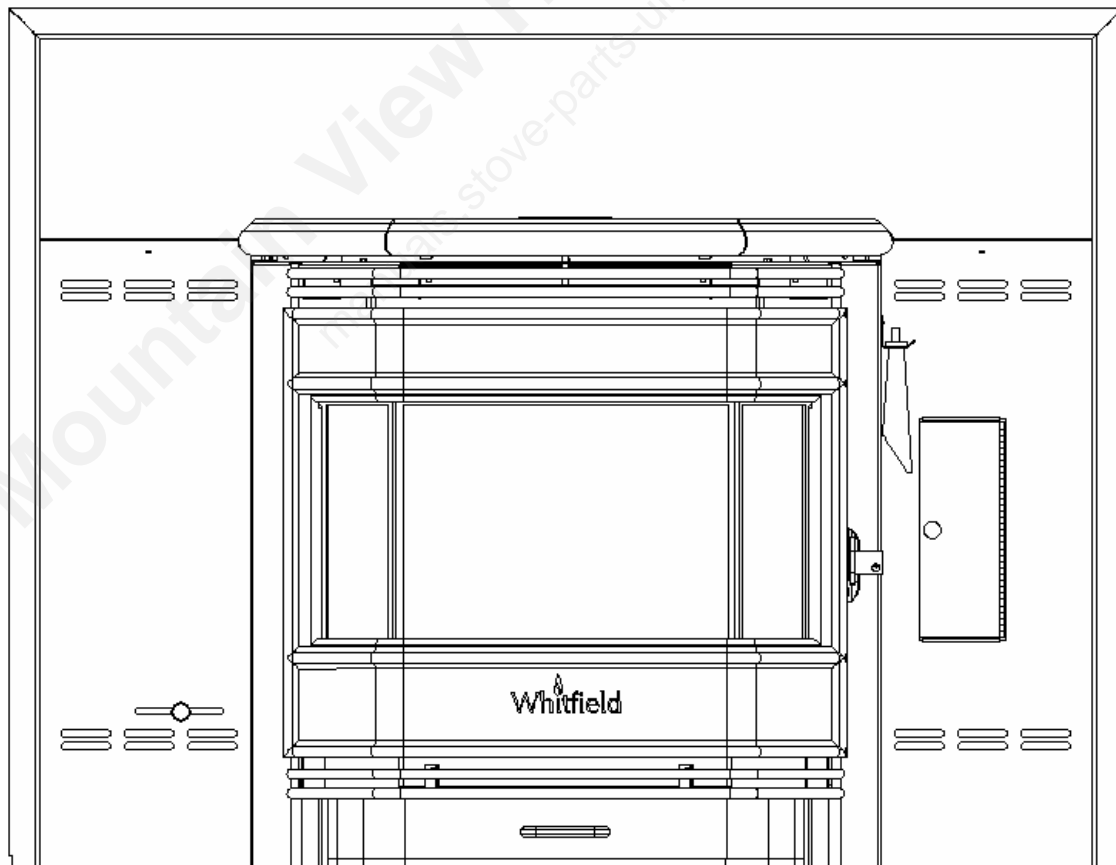

INSTALLATION

Optima 3 INS (Only) – Install damper rod knob as explained on page 11.

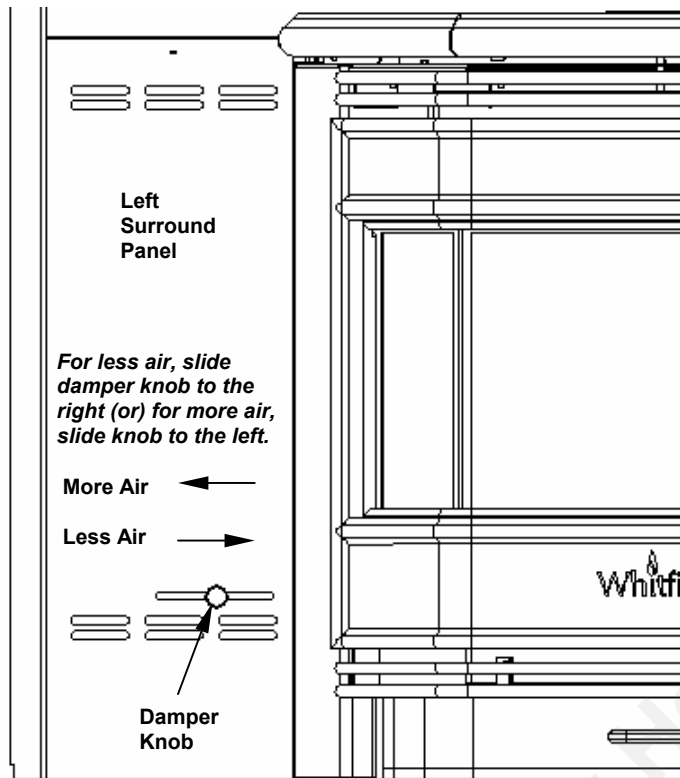

Adjustment Procedure: The damper knob should be positioned in the center of the oblong slot for the average installation (see illustration above). If more or less air is needed, then adjust in $\frac{1}{4}$ " increments until optimum combustion air flow is achieved (see Damper Adjustment Guidelines on page 26).

Damper Locations

See 'Opening Side Panels', page 33 for instructions on opening the side panels for models Optima 2 FS & Optima 3 FS. See 'Installing Surround Assembly' for instructions on side surround panel access for model Optima 3 INS.

Optima 2 FS - The damper control handle is located on the right-hand side panel.

Optima 3 FS - The damper control handle is located on the left-hand side panel.

Optima 3 INS - The damper control handle is located on the left surround panel.

Damper Adjustment

It is very important to preset your damper prior to burning your pellet stove.

Damper - Air Control Handle – Freestanding Units

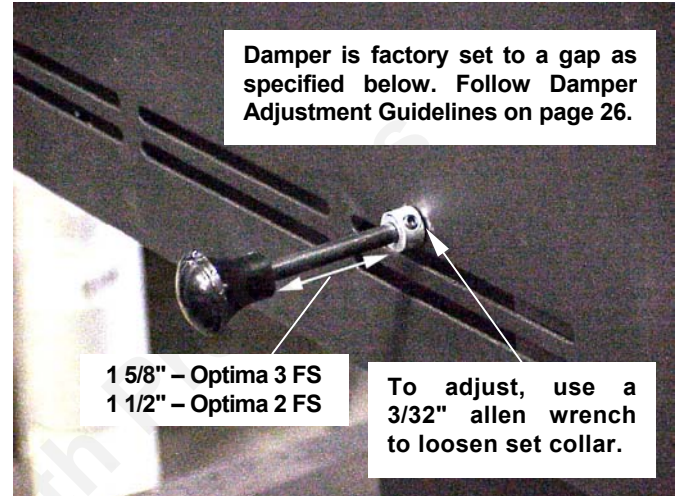

Adjustment Procedure: Loosen setscrew on set collar (see above picture), then adjust in $\frac{1}{4}$ " increments until optimum combustion air flow is achieved. For less air push in and for more air pull out. After adjustment, position set collar against side panel and tighten setscrew.

INSTALLATION

THERMOSTAT INSTALLATION:

NOTE: Always Disconnect Power Before Performing The Thermostat Installation.

A 24 volt wall thermostat and 20 feet of 18-gage thermostat wire is included in your stoves accessory package. It is recommended that the thermostat and thermostat wire be installed by an authorized Lennox Hearth Products dealer.

Installation Steps:

1. Unplug stove power cord from the wall outlet.
2. Locate the thermostat terminal block (see illustrations below).
3. Loosen the two terminal screws on the terminal block and remove the jumper.
4. Connect the two wires from your thermostat to the terminals (one per terminal). Ensure that the purple wires from the harness remain connected to the terminal block and tighten the terminal screws. Make sure the wires are firmly connected to the thermostat.
5. Plug in the stove and you are ready to operate with your thermostat!

IMPORTANT: IF THE WALL THERMOSTAT PROVIDED IS NOT USED, THE JUMPER IS REQUIRED FOR THE STOVE TO OPERATE.

Terminal Block for Thermostat

Leave Jumper on, If Thermostat Is Not Used

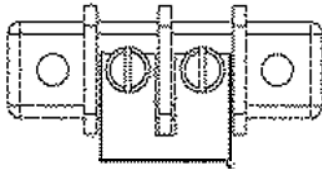

Remove Jumper if Thermostat Is To Be Used

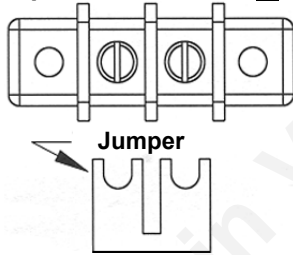

Model: Optima 3 FS

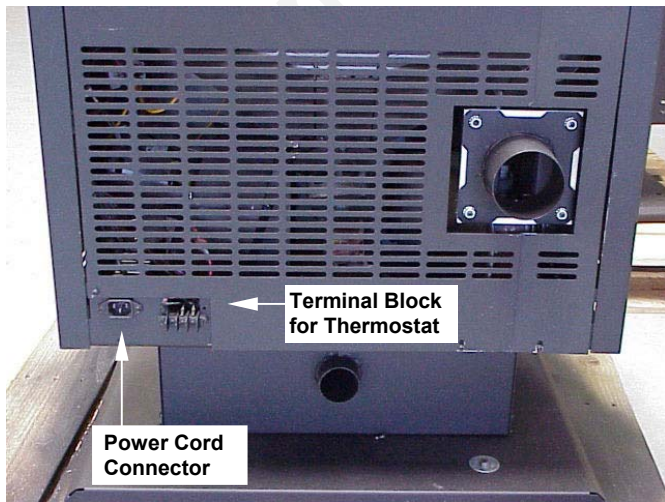

Model: Optima 3 INS
(on right side of insert when viewed from the front)

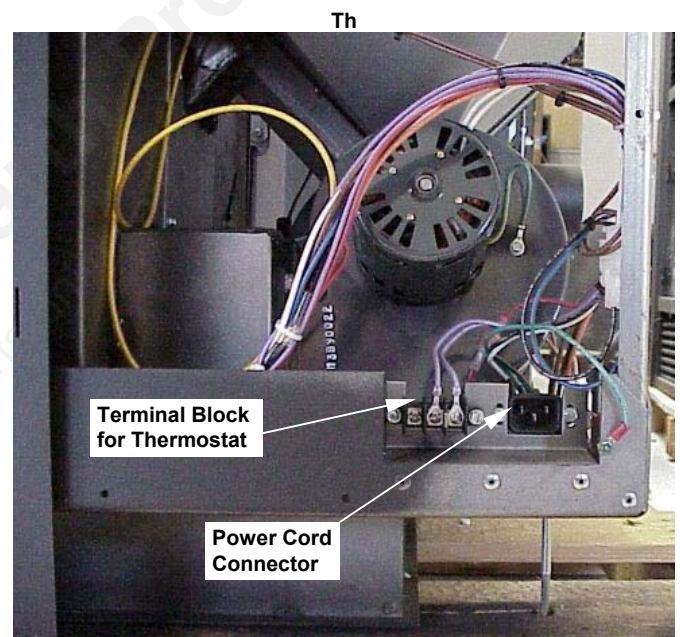

Model: Optima 2 FS
(viewed from stove back)

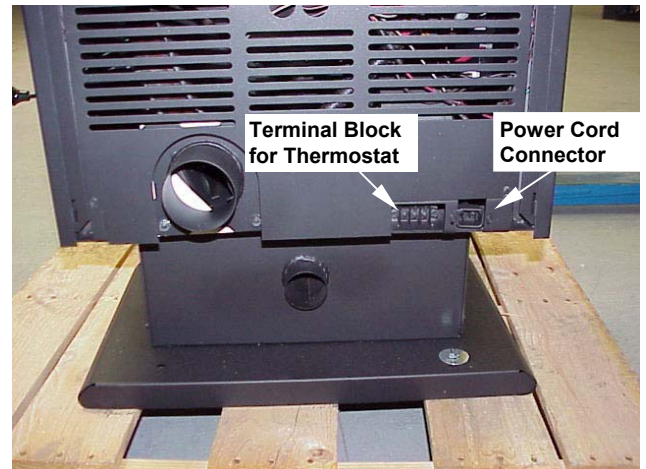

INSTALLTION

VENTING REQUIREMENTS

It is recommended that only an authorized dealer install your pellet stove. The specified installation requirements must be followed to ensure conformity with both the safety listing of the appliance and local building codes. All clearances, installation instructions and precautions specified by the vent manufacturer must be followed.

Selecting a Location (Freestanding Models)- Review the appliance clearance requirements before installing the venting system (see page 7). Position the appliance far enough away from walls to allow adequate room for servicing. Choose the appliance location with the least amount of interference with the house framing, plumbing, wiring, etc.

Preferred Vent Configuration – For the best performance, we recommend a vent run design which runs vertically and terminates above the roofline. This design will allow natural draft to improve the flow of flue gases and will aid in combustion and stove performance.

Type of Pipe - This stove requires type “PL” (pellet vent pipe, sometimes referred to as “L-Vent pellet vent”), which conforms to UL standard 641. Connect the pellet vent pipe or the “tee” to the flue collar using a minimum of three screws and seal as specified in “Pipe / Liner Joint Requirements” on this page. Do not use class B gas chimney or single wall chimney as a substitute.

Size of Pipe -These pellet appliances are approved for use with the following vent sizes: 3” (75mm) standard, or 4” (100mm). See page 16 for determining correct size vent to use. Use a 3” (75mm) to 4” (100mm) adapter (Cat. No. 14M81) or a 3” (75mm) to 4” (100mm) “tee” in order to run 4” (100mm) pipe.

Offsets - In every installation, a single or double clean-out “tee” is recommended for every ninety-degree offset (this tee will help collect ash residue and will allow for routine cleaning without the need to disconnect sections of pipe).

Note: Offsets and horizontal runs accumulate fly ash and soot which reduces the exhaust flow and performance of the stove.

Total Offsets in venting system should not exceed 270° total in direction change.

Horizontal Runs - The maximum total horizontal run must not exceed 10 feet (3.1 meters).

Horizontal run of pipe requires 1/4” / 7 mm rise per foot.

Pipe Clearances / Requirements – See pipe manufacturers instructions for installation of venting components and clearances. Follow pipe manufacturers installation precautions for passing pipe through a combustible wall or ceiling (i.e. use an approved thimble).

Notes:

All pellet vent pipe requires 3” (75mm) clearance from outside of pipe unless otherwise specified by vent manufacturer.

A support bracket should be installed every 4’ (1.2m) of pellet vent pipe on the exterior wall of the house unless otherwise specified by vent manufacturer.

Pipe / Liner Joint Requirements - All pipe joints must be secured with a minimum of 3 screws. ALL horizontal joints must be sealed gas tight (air tight, sealed connection). Use High Temperature RTV silicone with a rating of at least 570° F (969° C), or Interam to provide a complete seal at the flue collar and on all joints.

Connection to Masonry Chimney through a Wall (Freestanding Models) - Be sure to verify the construction of a masonry chimney, as it may have combustible framing.

Approved liner when relining Masonry or Factory Built Fireplaces is 2100HT (degree F.) liner listed to UL 1777 or ULC S635.

Connection to an Existing Class A Chimney (Freestanding Models) - A chimney adapter can be used to make the connection from 3” / 75mm or 4” / 100mm pellet vent pipe to existing UL chimney system. Verify with the pipe manufacturer that your pipe brands will interconnect.

Horizontal-Vent Installations - On all horizontal-vent installations (short, horizontal runs with no vertical pipe); care should be taken when choosing a location for terminating the vent. It is not recommended to directly vent the exhaust on the prevailing wind side of the house. It is recommended that when an appliance is vented directly through a wall, a minimum of 8’ (2.5m) of vertical pipe should be installed to create some natural draft. This will reduce the possibility of smoke or odor entering the dwelling during appliance shutdown or loss of power.

INSTALLTION

VENT TERMINATION

Do not terminate vent in an enclosed or semi-enclosed area such as: carports, garage, attic, crawl space, under a deck, porch, narrow walkway, closely fenced area, or any location that can build up a concentration of fumes such as a stairwell, covered breezeway etc.

Vent surfaces can get hot enough to cause burns if touched. Adults should supervise children when they are in the area of a hot stove. Non-combustible shielding or guards may be required.

Termination Cap: The termination of the outside chimney of the pellet stove shall be located in accordance with the following:

- A. Higher than 3' (.92m) above any forced air inlet (air conditioner, etc.) located within 10' (3m).
- B. Not less than 4' (1.2m) below, 4' (1.2m) horizontally from or 1' (3.1m) above any gravity air inlet (door, window, etc.) which flue gases could re-enter the dwelling.
- C. Not less than 2' (.6m) from combustible materials such as an adjacent buildings, fences, protruding parts of the structure, roof overhang, plants and shrubs, etc. and not less than 7' (2.1m) above grade when located adjacent to the public sidewalks (access). The final termination of the exhaust system must be configured so that flue gases do not jeopardize the safety of people passing by, overheat combustible portions of nearby structures or enter the dwelling.
- D. Not less than 3' (.92m) below an eave (maximum overhang of 3' (.92m) or any construction that projects more than 2" (51mm) from the plane of the wall.
- E. The distance from the bottom of termination to grade is 12" (305mm) minimum. This is conditional upon plants and nature of grade surface: Be careful to choose a location for the vent termination, which does not expose people or shrubs to high heat from the exhaust gases. The exhaust gases are not hot enough to ignite grass, plants and shrubs located in the vicinity of the termination although they should be a minimum of 3' (.92m) away. The grade surface under the termination must not be a lawn.
- F. Since sparks may escape from the exhaust pipe of any stove, use caution when positioning the vent pipe. Refer to pipe manufacturer's instructions when installing and terminating the exhaust. The vent pipe should be horizontal and **never run the pipe in a downward direction** (recommend a 1/4" (7mm) rise per foot horizontal).

Notes:

- It is not recommended to terminate exhaust vent on the prevailing wind side of the house.
- It is not recommended using a termination cap with a screen (fly ash can collect in a screen resulting in blockage).

Site Built Residential Home Chimney Height Requirements

The vent termination height required is - USA, 1-foot minimum; Canada 3-feet minimum above the roof penetration point as illustrated below (Ref. USA - National Standard, NFPA 211, Clause 7-4.1 and Canada National Standard CSA B365-01, Clause 5.6). Check with your local building official for additional requirements for your area.

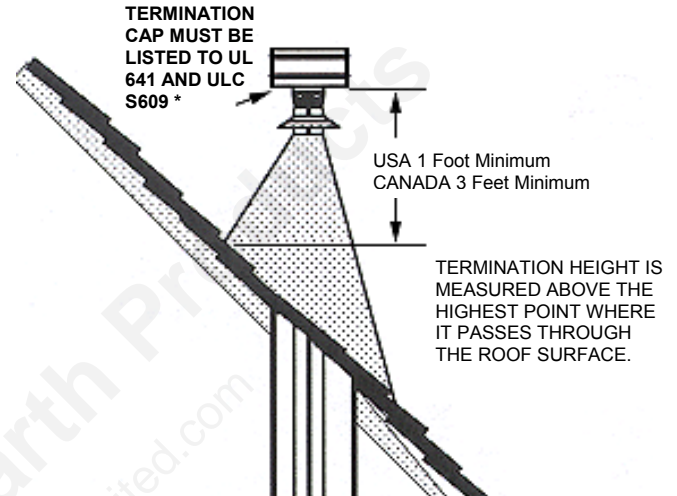

Manufactured (Mobile) Home Chimney Height Requirements

The chimney must extend 3' (.92m) above the level of roof penetration and a minimum of 2' (.61m) higher than any roof surface within 10' (3m) (see below). Check with your local building officials for additional requirements for your area.

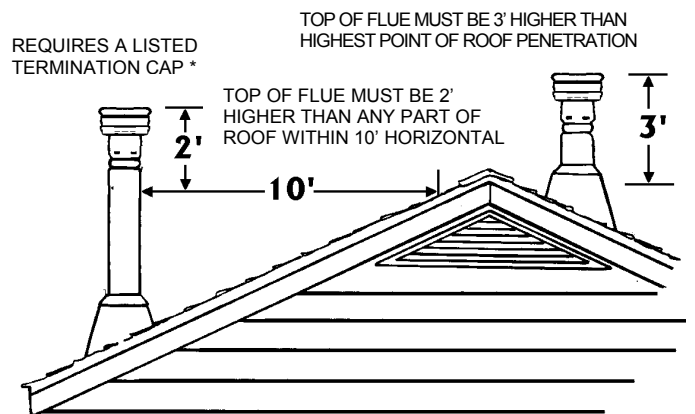

To pass inspection in nearly any jurisdiction, the chimney must meet both safety and exhaust flow requirements. The (3' by) 2' by 10' rule applies to both masonry and factory built chimneys.

*** Ref. NFPA 211 Clause 7 – 4.1.2, Vents installed with a listed cap shall terminate in accordance with the terms of the cap's listings.**

INSTALLATION

DETERMINING SIZE OF PIPE TO INSTALL

To determine what diameter pipe to use in an installation (3" or 4"), first find the "equivalent pipe length" using the following guidelines, then plot this figure and the altitude on the chart.

Fill out the installation chart, and calculate your total equivalent pipe length. After you have the total equivalent pipe length, use the *Pipe Selection Chart* below to determine if your installation requires 3" or 4" exhaust pipe.

INSTALLATION CHART

Type of Pipe	# of Elbows or Feet of pipe		Equivalent Feet	Total Equivalent Feet
90° Elbows / Tee (A & G)		x	5 Ft. (1.5m)	
45° Elbows (C)		x	3 Ft. (1m)	
Horizontal (B & F)		x	1 Ft. (.3m)	
Vertical (E)		x	.5 Ft. (.15m)	

SAMPLE INSTALLATION CHART

Type of Pipe	# of Elbows or Feet of pipe		Equivalent Feet	Total Equivalent Feet
90° Elbows / Tee (A & G)	2	x	5 Ft. (1.5m)	10 (3m)
45° Elbows (C)	1	x	3 Ft. (1m)	3 (1m)
Horizontal (B & F)	3	x	1 Ft. (.3m)	3 (1m)
Vertical (E)	8	x	.5 Ft. (.15m)	4 (1.2m)
				Total = 20

- A- 90 Degree Elbow
- B- 1' Horizontal Pipe
- C- 45 Degree Elbow
- D- Standoff Braces
- H- Wall Thimble

- E- 8' Vertical Pipe
- F- 2' Horizontal Pipe
- G- 90 Degree Tee

NOTE: All equivalent pipe styles shown to the right are standard for all freestanding models.

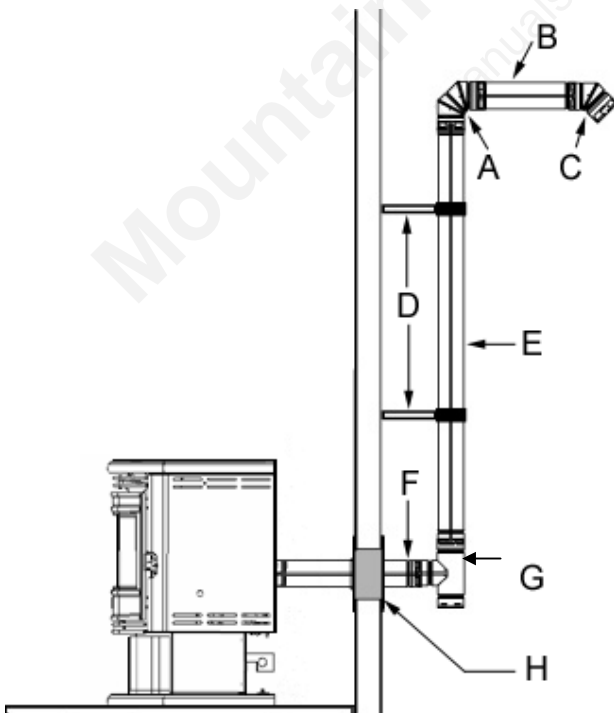

PIPE SELECTION CHART

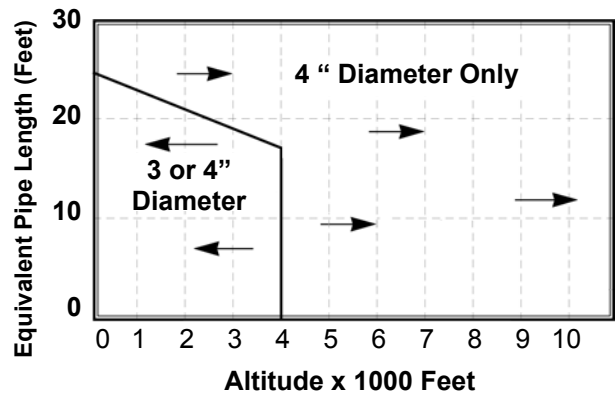

INSTALLATION

INSTALLING YOUR FREESTANDING PELLET STOVE

Standard Horizontal Vent Installation

1. Locate the proper position for the listed type "PL" wall thimble. Avoid cutting wall studs when installing your pipe. Use a saber saw or keyhole saw to cut the proper diameter hole through the wall to accommodate the wall thimble. Use extreme caution to avoid cutting into power lines within the wall of the home. The hole size will depend on the brand of pellet vent that you are using. Install the wall thimble in the hole.

ALL INTERLOCKING PIPE CONNECTIONS WITHIN THE ROOM MUST BE SEALED WITH High Temperature RTV AND SECURED WITH A MINIMUM OF 3 FASTENERS PER CONNECTION.

2. Position the stove approximately 12" (.3m) from the wall on the floor pad. Push listed type "PL" pipe through wall thimble. Squeeze a bead of high temperature silicone (High Temperature RTV) sealer around the end of the machined portion of the 3" (76mm) pipe connector on the back of the stove. Firmly push on a section of listed type "PL" pipe until inner pipe liner pushes into the bead of High Temperature RTV sealer.
3. Push the stove (with pipe attached) towards wall. Pipe will go through the wall thimble. Do not position the back of the stove closer than 2" (51mm) from the wall.

NOTE: Greater back clearance will improve the serviceability of the stove.

4. Install listed type "PL" 45 degree elbow with optional rodent screen or cap (recommended) on outside end of pipe. The rodent screen should be no less than 1/2" (13 mm) mesh and may clog with soot and ash if left unattended during the burn season.

NOTE: The end of the exhaust pipe must extend a minimum of 12" (.3m) from the outside of the building.

5. If the installation includes a source of outside combustion air; cut a separate hole through the wall for the fresh air tube. Use a galvanized or stainless steel pipe for the duct. The minimum size for the duct shall be not less than 50% of the cross sectional flue area. Connect outside air pipe to air inlet on stove. This tube must be terminated with a 45 degree elbow or hood.

NOTES:

Combustion air may also be drawn from a vented crawl space under the home.

All joints for connector pipe are required to be fastened with at least three screws. If vented horizontally, joints shall be made gas-tight (air tight, sealed connection) in a manner as specified on this page (see instruction #1). Install vent at clearances specified by the vent manufacturer.

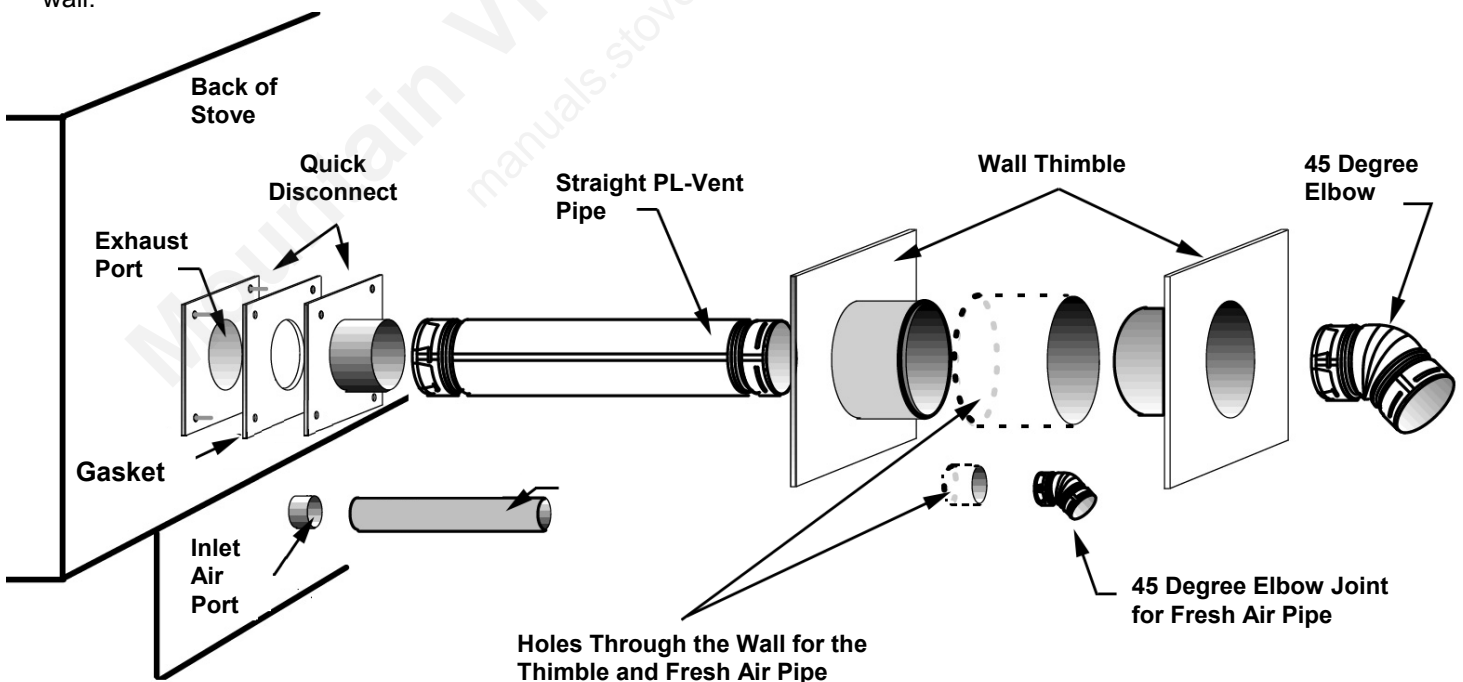

INSTALLATION

Standard Horizontal Installation Configurations

Optima 3 FS Corner Through the Wall

3" (75 mm) Minimum clearance between wall and pipe. If you vent to the furthest wall, the vent pipe must maintain a 3" clearance parallel to the other wall.

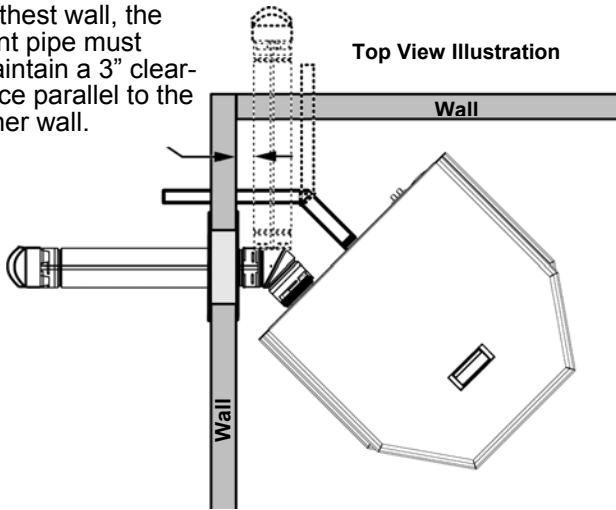

Optima 2 FS Corner Through the Wall

3" (75 mm) Minimum clearance between wall and pipe. If you vent to the furthest wall, the vent pipe must maintain a 3" clearance parallel to the other wall.

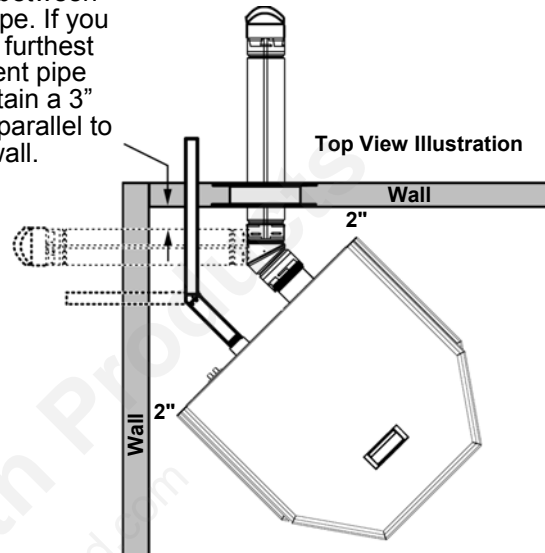

Optima® 2 FS and Optima® 3 FS Horizontal Vent Through the Wall

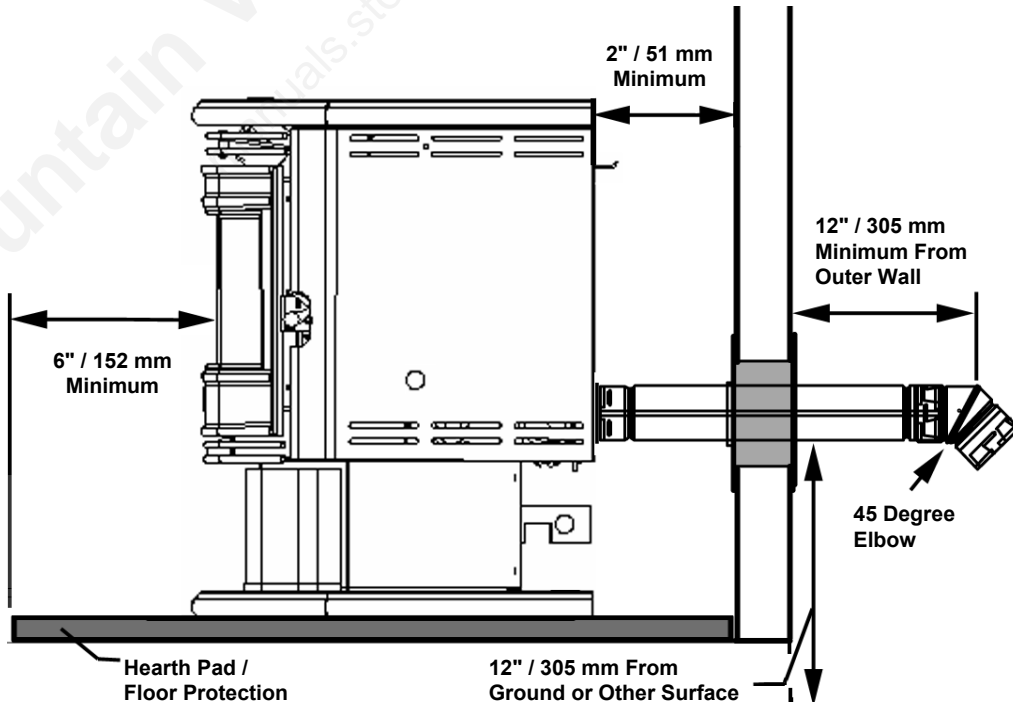

Note: Horizontal run of pipe requires 1/4" (7 mm) rise per foot.

INSTALLATION

Standard Vertical Installation Configurations

Models: Optima 2 FS and Optima 3 FS

These freestanding models may be connected to an existing flue or by installing listed type "PL" vent pipe. If a liner is run all the way to the top of the existing chimney, the existing flue should be sealed with a steel plate. Start a vertical run with a Tee at the back of the stove. Other options are illustrated below. *Note: See page 15 for Vent Termination Requirements*

Preferred Installation – Vertical Vent Through the Roof

This venting configuration allows for the best stove performance. The vertical pipe promotes natural draft and with the chimney inside the dwelling, the flue gases stay warm, thus rising at a consistent rate.

Exterior Vertical Vent

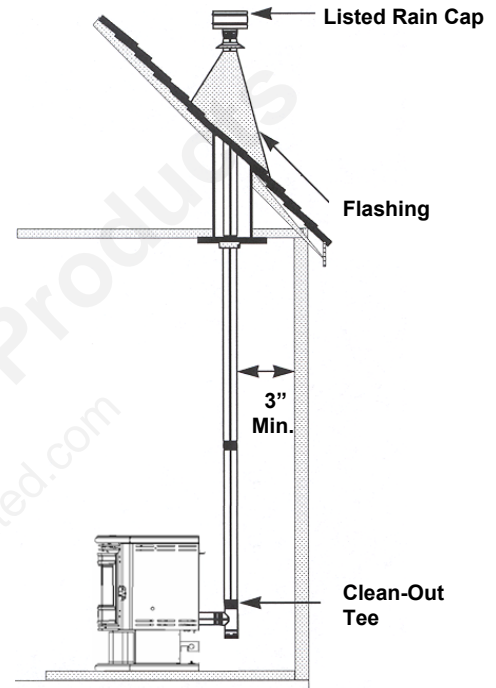
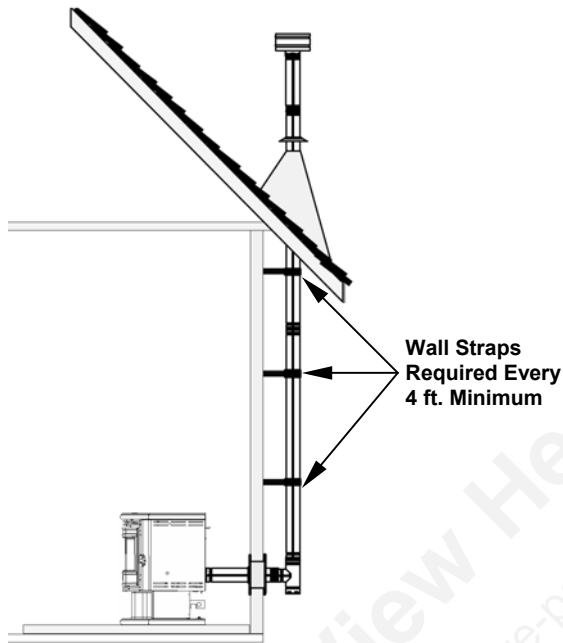

Vertical Vent Into A Masonry Flue

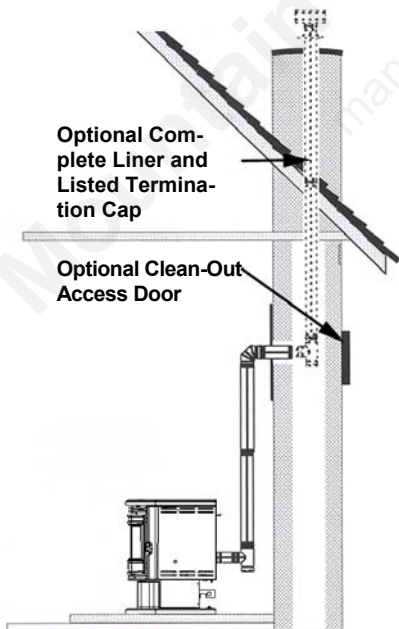

Interior Vertical Vent into an Existing Class A Chimney

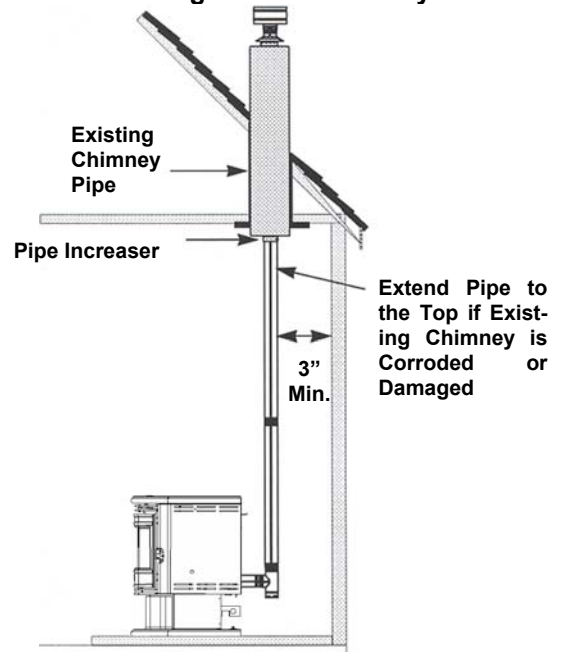

- ◆ **USA & Canada – Requires an approved noncombustible hearth or floor protector, 3/8" / (10 mm) millboard or equivalent (k = .84, r = 1.19) to extend 6" / 150 mm to the front of the glass door.**

INSTALLATION - Optima 3 INS

Standard Installation Configurations Into and Existing Fireplace – Model: Optima® 3 INS

IMPORTANT- Make sure the chimney and firebox are clean and free of soot and ashes before installation begins. Failure to do so may result in the transfer of soot into the room by way of the room air blower.

(USA only) Venting Into an Existing Chimney

This pellet insert may be installed into a masonry fireplace (built to UBC 37 or ULC S628 standards) or a factory built fireplace (built to UL 127 or ULC S610 standards) as illustrated on this page. When installing into a masonry chimney, it is recommended that the exhaust vent be extended to the top of the chimney as shown on the following page. However, if the vent pipe does not extend to the top of the chimney, the vent must extend a minimum of 18" above the damper. You must seal the damper area so that the air / exhaust in the chimney cannot communicate with the air in the fireplace firebox (this is a positive flue connection. See the following instructions for one method of sealing flue).

(USA & Canada) Direct Connection / Positive Flue Connection

In Canada, this appliance requires a full reline when installing into a masonry fireplace. In the USA, as a minimum the vent connector from the insert flue outlet must extend a minimum of 18" above the damper and the damper area must be sealed to prevent dilution air from entering the chimney which will affect proper drafting of appliance.

See the following instructions for acceptable methods for sealing chimney throat.

Approved Methods of Achieving a Positive Flue Connection - A qualified installer should evaluate the existing fireplace to determine the best method for achieving a positive flue connection between the vent pipe or liner and the chimney. The most common method for achieving a positive flue connection in masonry fireplaces is to secure a seal-off plate (i.e. 22-gage sheet steel) in the fireplace throat using masonry screws. Other acceptable methods include packing noncombustible material (i.e. rockwool) around the vent pipe or using a flue adapter. Whatever "seal off" method is used must effectively seal the area to prevent room air passage to the chimney cavity of the fireplace.

Direct Connection (not allowed in Canada)

The vent pipe must extend a minimum of 18" above the damper. The chimney must not be corroded or damaged in any way for this type of installation to be permitted.

A non-combustible seal is required at the damper area (to prevent dilution air from entering the chimney). See Positive Flue Connection Methods on this page.

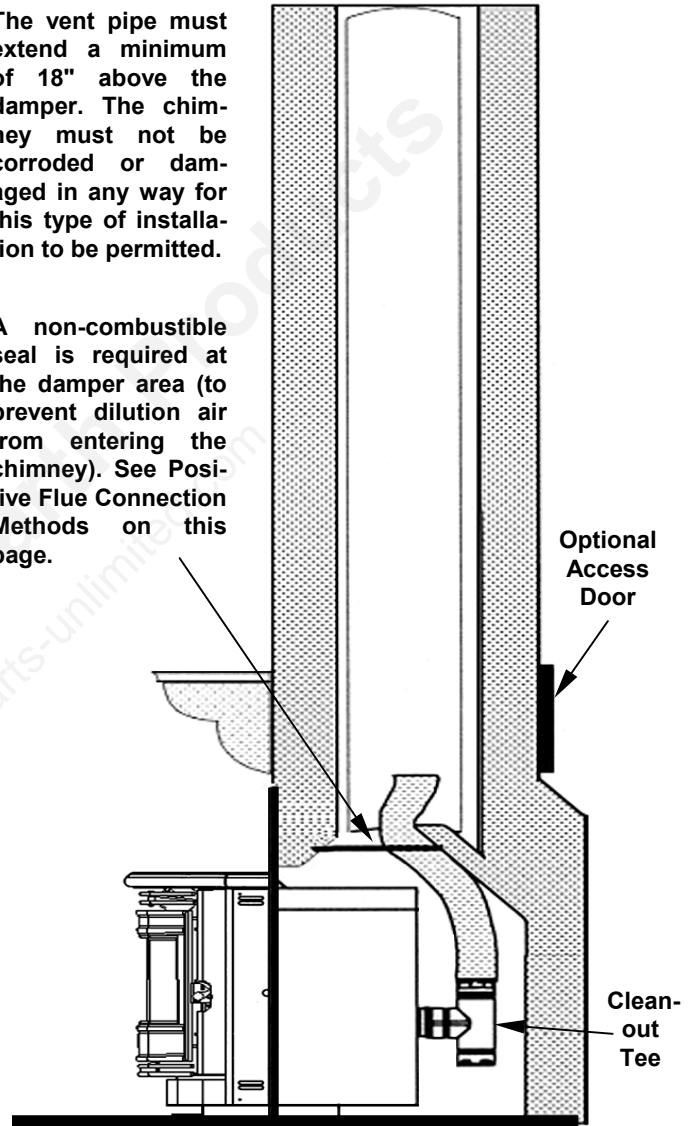

- ◆ **USA & Canada – Requires an approved noncombustible hearth or floor protector, 3/8" / (10 mm) millboard or equivalent (k = .84, r = 1.19) to extend 6" / 150 mm to the front of the glass door.**

INSTALLATION

INSTALLING OPTIMA 3 INS (CONTINUED)

IMPORTANT- Make sure the chimney and firebox are clean and free of soot and ashes before installation begins. Failure to do so may result in the transfer of soot into the room by way of the room air blower. Do not block opening at front of insert (below door).

Full Chimney Reline (Recommended for ALL chimney installations)

Approved Liner for Factory Built (ZC) Fireplaces and Masonry Fireplaces is 2100HT (degree F.) liner listed to UL 1777 or ULC S635.

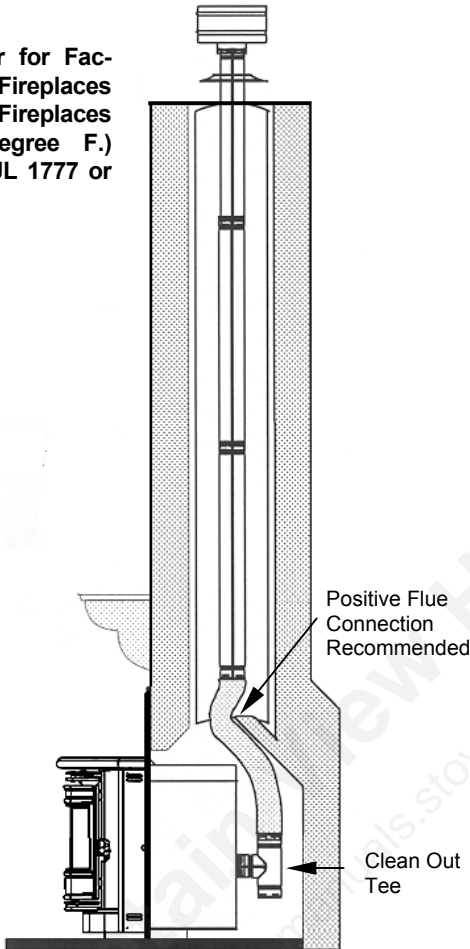

Horizontal Vent (Direct Vent)

IN CANADA – Installing as a Horizontal Vent is not allowed. The fireplace chimney must be fully lined.

U.S.A. – The insert may be installed as a Direct Vent (horizontal vent through the chimney structure) in masonry fireplaces if local codes will permit.

Canada – Installing an insert as a Direct-Vent is not allowed. The fireplace chimney must be fully relined from the insert outlet to termination.

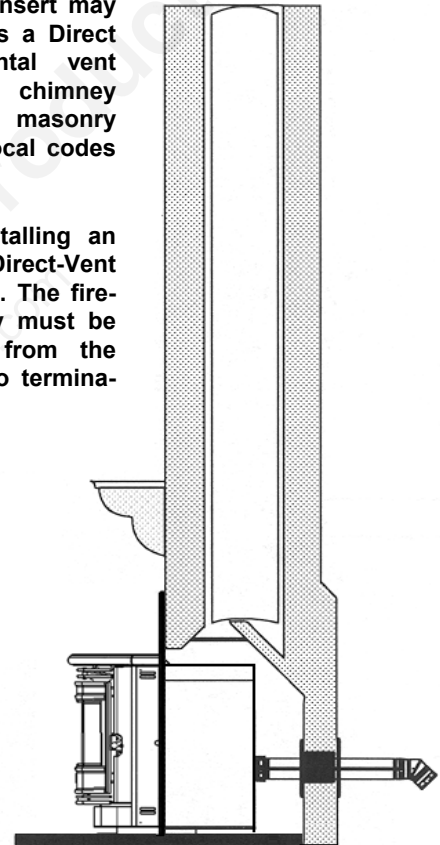

VENT TERMINATION WHEN LINER IS USED.

A section of pellet vent pipe is required at the top where exposed to the elements (see illustration below).

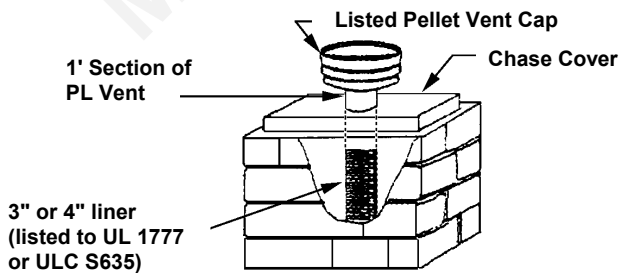

- ◆ **USA & Canada – Requires an approved noncombustible hearth or floor protector, 3/8" / (10 mm) millboard or equivalent (k = .84, r = 1.19) to extend 6" / 150 mm to the front of the glass door.**

CARE AND OPERATION

CONTROL BOARD OPERATION

Stove On / Off Button – This button will turn your stove on or off while in Manual or Automatic mode (see page 25 for details). The green on / off light at the top of control board will indicate the on / off status.

Heat Output Button – The heat output button has three selection settings, Low, Medium and High. Pressing the button will scroll the red indicator lights from Low to High. The button controls the pellet feed and combustion airflow simultaneously. The control board is preset to provide the optimum ratio of fuel and air at each setting. Settings can be changed at any time but will only take affect after the start-up cycle is complete. Each press of the Heat Button will increase the heat output, and will scroll to the lowest setting after reaching the maximum setting.

Blower – The blower button operates the room air blower. This will change the flow of hot air into the room. Three choices are available Low, Medium, and High. When the Blower Button is pressed the yellow indicator light will scroll to Low, Medium, or High.

When running your stove on high heat output, the control board will not allow you to select the low blower speed. This is a safety precaution to protect against overheating. Blower settings can be changed at any time, but will only take affect after the start-up cycle is complete.

Fault Mode – The control system automatically monitors the flame using a photoeye. If the stove runs out of pellets the control board automatically goes into a “fault” status. The control board will initiate the shut down cycle and safely shut down the stove leaving it in the “fault” mode. The on / off indicator light near the top of the control board will flash rapidly when in this mode. After refilling the hopper with pellets, press the Start Button. If a thermostat is not being used the

stove will go into the start-up cycle. If a thermostat is being used the stove will go into the start-up cycle if the thermostat is in the demand mode. If the thermostat is in the stand-by mode when the fault is cleared, the stove will remain in the stand-by mode until it closes again.

NOTE – If the fuel feed trim or combustion air trim needs to be adjusted, contact an authorized Lennox Hearth Products Technician to calibrate internal software. It is recommended that the damper be used to fine-tune your stove to your particular fuel and installation configuration (see *Damper Adjustment* on page 12 and *Damper Adjustment Guideline* on page 26).

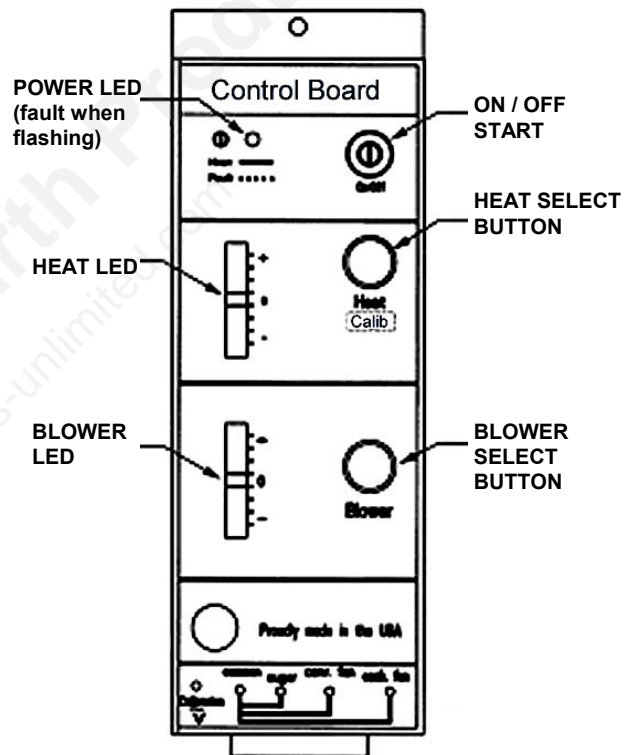

CARE AND OPERATION

Note: The control board is equipped with an internal memory which will recall the last setting and mode the stove was in prior to loss of power. Because we individually check each stove prior to packaging, one of the two scenarios will appear when you first plug in your stove.

- 1). The Green LED at the top of the control board will illuminate and the blowers will be running. This is a standard cool down mode and will last no longer than five minutes. This happens during testing when the stove is turned off (which initiates cool down mode) and then is unplugged.
- 2). The Green LED at the top will illuminate and the red and yellow LED's will illuminate on the control board, indicating that the stove is in the run mode. This happens during testing if the stove is unplugged without first turning the control board off (the control board remembers its last setting, which was the run mode).

If your stove follows that described in number 2 above, simply press the ON / OFF button once to turn the stove off, this will initiate the cool down mode. The stove can be restarted at any time during the cool down mode by pressing the ON / OFF button once.

Start-up Sequence of Events

1. Fault time delay is initiated (14 minutes 15 seconds).
2. Fuel feed rate of 100% for 1 minute 50 seconds (when trim left at factory setting of 0) auger trim setting ranges from 1:26 to 2:14 depending on -4 to +4 respectively.
3. Exhaust blower operation starts (medium range voltage).
4. Room air blower operation starts (medium range voltage). Power LED is activated (steady green).
6. Igniter operation activated (line voltage).
7. Photoeye looks for flame (flame dominance scheme).
8. * If needed second & third fuel dumps are available at predetermined time deliveries (4 minutes & 6 minutes after initial).

Flame Detection Sequence of Events - This is what happens after flame has been detected.

- Happens within the *Start-up Time Delay* sequence.
- 0 to 1 minute no fuel feed.
- Flame settles.
- Bed of embers built.
- 1 minute mark: Fuel Feed rate 20% for 4 minutes 15 seconds (1 second on / 4 seconds off).
- 2 minute mark: igniter turns OFF / room air blower = panel setting.
- 5 minute 15 seconds mark: exhaust blower = panel setting / LED indicator still active. **Start-up Time delay ends 14 minutes 15 seconds after pushing the start button!**

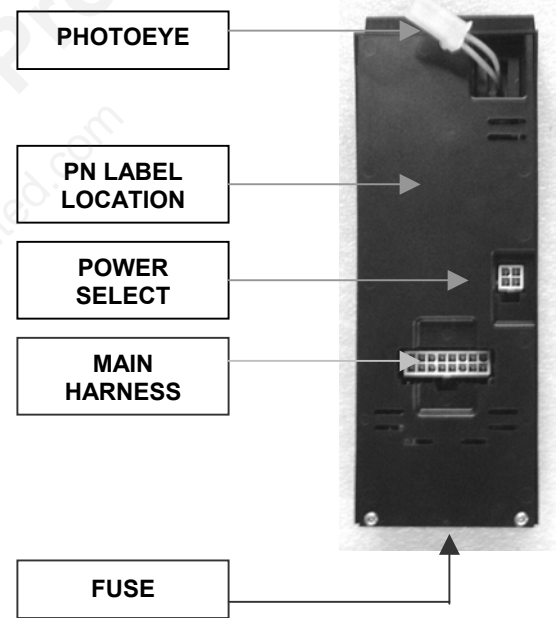

CARE AND OPERATION

Combustion Voltage Trim Steps:

1. Push button "twice" for access voltage calibration mode.
2. Identify the current calibration setting indicated by one YELLOW LED bar.
3. Push the "HEAT" control button to adjust setting UP. Each push raises the YELLOW LED bar & increases voltage 5%.
4. Push the "BLOWER" control button to adjust setting DOWN. Each push lowers YELLOW LED bar decreasing voltage 5%.
5. Push the calibration button once to lock in selected results.

Fuel Delivery Rate

The feed rate button manages the fuel delivery rate by controlling the amount of time the auger motor will run as follows:

Optima 2 FS

Feed Rate Setting	Auger Motor ON / OFF Time (seconds)	* Lb.'s per hour fuel delivery	◆ Approximate BTU per hour fuel delivery	Burn Time (hours)
Low =	1 on/5.40 off	1.5 Lb.'s/hr.	13,000 BTU/hr	37
Med.=	1 on/3.30 off	2.5 Lb.'s/hr.	21,000 BTU/hr	22
High =	1 on/1.75 off	3.8 Lb.'s/hr.	32,000 BTU/hr	15

Note: Maximum hopper capacity is 55 lb.'s

Optima 3 FS

Feed Rate Setting	Auger Motor ON / OFF Time (seconds)	* Lb.'s per hour fuel delivery	◆ Approximate BTU per hour fuel delivery	Burn Time (hours)
Low =	1 on/4.50 off	1.7 Lb.'s/hr.	14,000 BTU/hr	41
Med.=	1 on/1.90 off	2.6 Lb.'s/hr.	22,000 BTU/hr	27
High =	1 on/1.15 off	4.5 Lb.'s/hr.	38,000 BTU/hr	16

Note: Maximum hopper capacity is 70 lb.'s

Optima 3 INS

Feed Rate Setting	Auger Motor ON / OFF Time (seconds)	* Lb.'s per hour fuel delivery	◆ Approximate BTU per hour fuel delivery	Burn Time (hours)
Low =	1 on/4.50 off	1.7 Lb.'s/hr.	14,000 BTU/hr	30
Med.=	1 on/1.90 off	2.6 Lb.'s/hr.	22,000 BTU/hr	20
High =	1 on/1.15 off	4.5 Lb.'s/hr.	38,000 BTU/hr	11

Note: Maximum hopper capacity is 50 lb.'s

* Feed rates are approximations only. Actual feed rate will vary depending on size, quality and length of fuel used and variations in line voltage.

- ◆ Estimated heat input based on fuel value of 8400 BTU per lb. of fuel.

Your pellet stove can be operated in either manual or automatic mode. The manual mode is used when operating without a thermostat. The automatic mode is used when utilizing a wall thermostat. When utilizing the thermostat capability the burn time can be extended dramatically depending on thermostat setting. Note: It is normal for some ash to build up on the inner glass surface at the lower burn settings.

Initial Start-Up / Empty Hopper or Feed Tube:

During an initial start-up, or in the case where the hopper has run out of fuel, it will be necessary to prime the auger feed system. The control board is set to deliver fuel for approximately 2 1/2 minutes during start-up, which, with a fully primed auger tube, will provide the appropriate amount of fuel for ignition.

When first starting your pellet stove, it will be necessary to prime the auger tube. To prime the auger tube you need to first fill the hopper with pellets, and press the ON button on the control board. Wait approximately 2 1/2 minutes and turn the control board OFF and then back ON again. Wait an additional 2 1/2 minutes (if necessary) and continue this process until fuel begins to fall into the UltraGrate™. Remember, different brand fuels feed at different rates.

Once fuel starts to enter the UltraGrate™, turn the stove OFF and then back ON. The auger tube should now be primed and the stove should deliver enough fuel for proper ignition. It may be necessary to follow these procedures in the event that the hopper runs completely out of fuel.

CARE AND OPERATION

MANUAL OPERATION

Pressing the stove on / off button initiates the start-up cycle. The green on / off light, near the top of the control board, will light up to indicate the “on” status. The fan speeds and pellet feeds are fixed during this time to provide appropriate ignition. The Fast-Fire igniter system will light the pellets feeding to the UltraGrate™, after about 3 minutes. The start-up cycle is in effect for approximately 2 minutes after flame is detected in the UltraGrate™. A photoeye, monitors the existence of flame. After the start-up cycle your stove will be in the run mode. At this point the stove will operate in the heat output and blower settings selected. These settings can be selected either during or after the start-up cycle. Pressing the stove on / off button during the run mode will initiate the shut down cycle. The on / off indicator light will turn off. The pellets will stop feeding and the blowers will run at a fixed speed for approximately 10 minutes. At this point your stove is safely shut down and can ONLY be re-started by pressing the stove on / off button again.

AUTOMATIC OPERATION

Your stove is capable of running in an automatic mode with the use of a wall thermostat. NOTE: For the thermostat to control the operation of the stove, the “on” status must be active on the stove’s on / off button. The thermostat will establish either a demand mode or a stand-by mode. The thermostat should be set for the desired room temperature. If the room temperature drops below the level on the thermostat the stove will automatically begin the start-up cycle, as explained above in the Manual Operation section. Once the start-up cycle is completed the stove will operate in whatever heat and blower setting you have selected. For best operation under thermostat control, the Medium or High settings recommended. When the desired room temperature is reached, the stove will automatically go into the shut down cycle. The pellet feed will stop and the blowers will continue for a controlled time allowing safe shut down of your stove. All lights will remain on when the thermostat is open. The heat and blower settings can be changed at any time, but only take affect during the run mode. When the temperature in the room drops to the level set at the thermostat, the stove will again begin the start-up cycle and resume automatic operation in the demand mode.

NOTE: If the stove on / off button is pressed while the thermostat is in the standby mode the stove will not re-start until the thermostat closes.

LIGHTING PROCEDURE WITHOUT IGNITER

Your pellet stove can be lit manually without using the automatic igniter by following the procedure below. If your stove is set up to run on a thermostat, the thermostat circuit needs to be closed (as if permanently in the demand mode). The thermostat wires should be removed from the rear of the stove and replaced with the jumper originally supplied with your stove. If a jumper is not available the thermostat should be set to the highest setting. This will keep the stove in the demand mode. If your automatic ignition system should ever need troubleshooting, repair or replacement, please contact your authorized Lennox Hearth Products dealer.

1. Press the ON button on the control board.
2. Wait approximately 2 1/2 minutes while the pellets prime the grate (the pellets will stop feeding automatically).
3. Place a small amount of an approved (non-volatile) fire starter on top of the pellets in the grate, (see your authorized Lennox Hearth Products dealer for appropriate fire starting products). DO NOT USE FLAMMABLE LIQUIDS TO START YOUR STOVE!
4. Light the “fire starter” with a match and close the door.
5. The photoeye will detect that a flame is present and will begin feeding pellets in approximately 2 minutes.
6. The control board will continue to go through the normal start-up cycle and the flame should be well established within 10 minutes from the time the ON button was initially pressed. Remember – you are now in manual mode and heat settings should be selected to the desired room heat level.

TURNING OFF YOUR PELLETT STOVE

Press the stove on / off button to initiate the shut down cycle. The pellets will stop feeding and the blowers will continue to run on a timed cycle. The stove will shut down safely upon completion of the shut down cycle.

CARE AND OPERATION

DAMPER OPERATION (All models)

The damper is a plate that helps control the amount of airflow supplied for combustion. With the damper pushed all the way in the airflow is at its minimum. As the damper is pulled out, more air is allowed to flow.

It will be necessary to monitor the appearance of the flame during the first 4-8 bags of pellets. If your flame is smoky red / orange with evidence of soot at the top of the flame, you need more combustion air; pull the damper out one notch and re-evaluate the appearance of the flame. It may be necessary to continue this process, moving the damper one notch at a time until proper combustion is attained (the flame should become yellow and begin to “dance”). If the flame is “short” at the higher burn rates, or if the pellets are burning up in the grate before new pellets are fed into the fire, push the damper in one notch and monitor the flame. Continue the process of moving the damper one notch at a time and evaluating the flame until proper flame appearance is achieved.

Once the damper has been properly set, it should not need adjusting unless you are changing the grade of pellet fuel, in which case the damper may need to be adjusted.

DAMPER ADJUSTMENT GUIDELINE

Lack of Combustion Air: By opening the damper, this will increase combustion air delivery. Symptoms of insufficient combustion air include; unburned fuel, lazy smoky or red / orange flame, excessive ash or soot, excessive buildup on glass.

Contributing factors:

- High Altitude – Lack of oxygen
- Restrictive Venting (elbows, horizontal runs, cold external chimneys, etc.).
- Dirty / Poor Quality Fuel.

Note: Excessive amounts of fly ash built-up in the grate, clinkers in the grate or leakage of air (if the grate is not properly seated) will starve the fire for air. See *Routine Maintenance*, on page 28 to 33 for information on cleaning the stove.

Excessive Combustion Air: By closing the damper, this will reduce combustion air delivery. Symptoms of excessive air include; fuel burns too quickly (results in smoking or smoldering pellets), white to yellow flame, etc. If the damper is open too much, the burning pellets will lift off the grate and fly up into the air much like popping corn does.

Contributing factor:

- Venting system providing excessive draft.

Correct Combustion Air / Proper Burn Characteristics: When the damper is correctly set, the burning pellets should move (wiggle) around slightly and the flame should be bright yellow.

AUTOMATIC SAFETY FEATURES

Power Outage:

During a power outage, the stove will shut down safely. The stove will automatically restart when power is resumed. The solid state control board has an internal memory that will retain heat output and blower speed settings through voltage interruptions.

A small amount of smoke may leak from the top of the window glass, the hopper and from the combustion air intake, if the stove is vented horizontally with no vertical pipe. This will not persist for more than 3 to 5 minutes and will not be safety hazard. It may set off your smoke alarm.

Note: If the area in which you live is prone to frequent power outages, it is recommended that a minimum of 8 feet (2 ½ meters) of vertical vent pipe be included in a freestanding installation to induce a natural draft in the event of a power failure.

Overheating:

A high temperature disc (thermal switch) will automatically shut down the stove if it overheats. Allow up to 45 minutes cooling time before re-lighting. Keep enough convection air (from the room air blower) going through stove to keep it cooling properly, this will ensure long life of the stove. If the overheating continues, contact your authorized Lennox Hearth Products dealer for more information.

CARE AND OPERATION

FUEL

Clinkering - Silica (or sand) in the fuel, along with other impurities, can cause clinkering. A clinker is a hard mass of silica formed in the burning process. Clinkering is a function of the fuel, (not the stove), but adversely affects the performance of the stove by blocking off the air passages in the grate. Even P.F.I. approved pellet fuel may tend to clinker. A clinker can be removed from the UltraGrate™ and placed in the ash pan with the use of the grate scraper / ash pan tool furnished with your stove. See *Routine Maintenance* (pages 28 - 33) for more information on cleaning.

Ash - The frequency of removal of the ash and maintenance performed on the stove is directly proportional to the ash content of the fuel and the operation duration of your pellet stove. Low ash fuel may allow longer intervals between cleaning, however, a stove burning high ash fuel may need to be cleaned as often as everyday.

PLEASE NOTE: Lennox Hearth Products has no control over the manufacturing of pellet fuel and will not be held responsible for poor stove performance or any damage caused by poor quality pellet fuels.

Fuel Feed Rates - Different brands of pellets will feed at varying rates due to their size and density (length and diameter). This may require a slight adjustment in the damper control (see pages 12 & 26) or the fuel feed trim to compensate (see note on page 22).

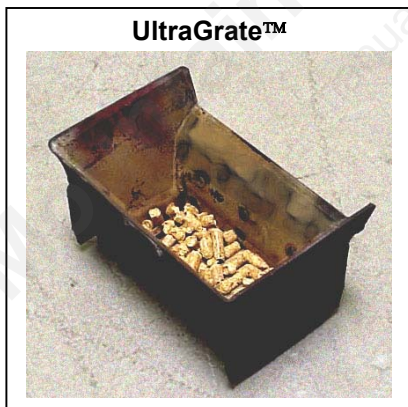

Fuel Specifications - Using the UltraGrate™ burn system, this appliance has been designed to burn wood residue pellets with up to 3% ash content. Agricultural pellets (i.e.... Corn, alfalfa etc.) are not permitted to be burned in the stove. Dirty fuel will adversely affect the performance of the stove.

Caution: The use of unapproved, dirty, wet and / or high salt content fuel will void the warranty!

Wood pellets manufactured to the pellet fuels institute (P.F.I.) certification standard are available in two grades, Standard and Premium. The primary difference between the two is the ash content of the pellets.

The P.F.I., specification for standard grade & premium grade residential pellet fuel is as follows:

- CHLORIDES (Salt): Less than 300 p.p.m.
- BULK DENSITY: 40 lb. / Cu. Ft. minimum
- MOISTURE CONTENT: 8% maximum
- ASH CONTENT: < 3% maximum (standard grade) < 1% maximum (premium grade)
- FINES: 0.5% maximum through a 1/8" screen
- BTU CONTENT: Minimum 8200 BTU per pound.

Pellet Feed / Pellet Size - The pellet feed system is designed to handle a wide range of pellet sizes up to a maximum of 5 / 16" diameter. Different pellets may feed at considerably different rates. You may notice a difference in the burn if you change pellet fuel sizes. The longer the pellet, the slower it will feed and vice versa. If the stove will not stay burning at the minimum fuel feed setting, those particular pellets may not be feeding fast enough. If this happens, reduce the amount of combustion air by adjusting the damper. See pages 12 & 26 before adjusting the damper.

Long Burn Time - When operated correctly, this appliance cannot be overfired. Continuous operation at a maximum burn can, however, shorten the life of the electrical components (blowers, motors, and electronic controls), and is not recommended. Typical approved operation would include running at the low to mid range setting with occasional running on the maximum setting during the coldest periods of the winter. The blower speed control should be turned to high when operating the stove on the high heat setting. A lower heat setting is recommended for overnight operation or when the room is vacated for long periods of time.

Note: See *Fuel Delivery Rate* on page 24 for burn times.

ROUTINE MAINTENANCE

* Inspect your stove or insert at minimum frequency stated until you establish a minimum frequency required for your installation (frequency will vary depending upon fuel BTU value / ash content, usage, and misc. installation variables). **Unplug and Ensure Stove is Cold Before Performing Any Maintenance Work.** Include routine maintenance with annual maintenance. The following areas need to be inspected and cleaned as part of annual maintenance:

ROUTINE CLEANING

Unplug and Ensure Stove is Cold Before Performing Any Maintenance Work.

The following areas need to be inspected and cleaned during Routine Cleaning:

- UltraGrate™ (burn grate)
- Ash Pan
- Heat Exchange Tubes / Tube Scraper
- Photoeye
- Exhaust Passages and Vent Pipe
- Ash Clean-out Ports
- Gaskets
- Window Wash
- Rear Stove / Insert Compartment

UltraGrate™ (Burn Grate for All Models)

The UltraGrate™ should be inspected periodically to assure that the air holes have not become clogged with ash or clinkers. The UltraGrate™ can easily be cleaned with the grate scraper / ash pan tool, or it can be removed for cleaning. It is very important to monitor the ash build up under the UltraGrate™, as excessive amounts of ash will block combustion air from entering the grate, causing pellets to pile-up in the grate. The grate cleaning procedure is the same for all models.

UltraGrate™



* (Minimum Frequency of 1 day to 2 weeks)

ASH PAN (Optima 2 FS and Optima 3 FS)

All ash removal and cleaning should be done while stove is cold.

The ash pan will have to be emptied periodically, depending on the amount of fuel consumed. To access follow steps one through four:

1. Open the glass door, then, using the ash pan / grate scraper tool, lift the UltraGrate® out and sweep the top ash into the pan below.
2. Remove the ash pan cover located below the door by pulling forward until magnets release.

Models Optima 2 FS and Optima 3 FS



Model Optima 3 INS



* (Recommended Frequency of 2 days – 2 weeks)

Optima 3 INS has a handle on the exterior of the ash pan cover for easy access and removal.

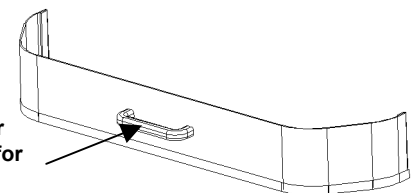

ROUTINE MAINTENANCE

3. Release both ash pan latches and pull forward.

Models Optima 2 FS and Optima 3 FS

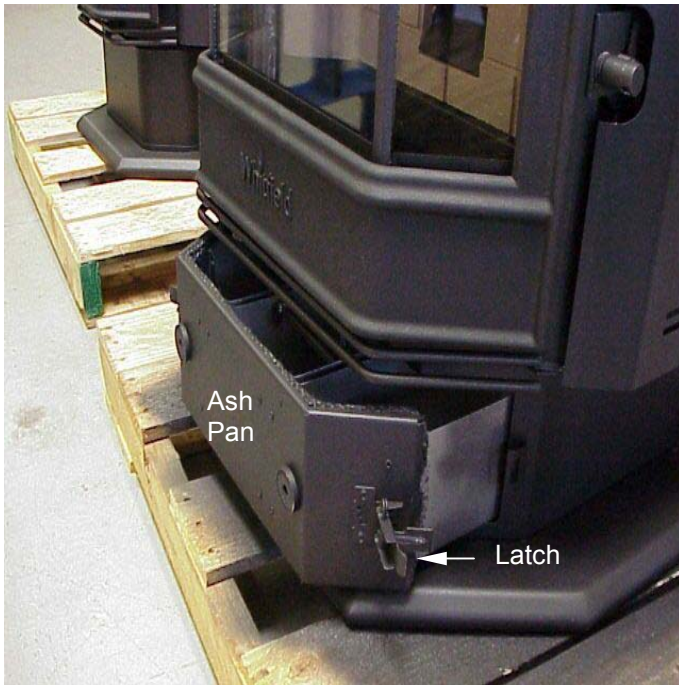

Model Optima 3 INS

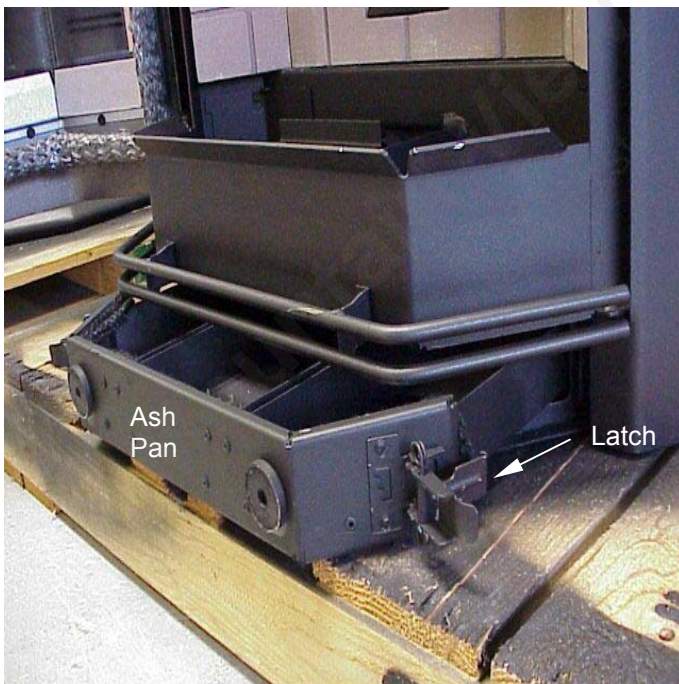

4. Remove the ash pan. Place ashes into a non-combustible container. When finished, close the glass door and slide the ash pan back into the stove and close the ash pan door. Reinstall ash pan cover panel.

* (Minimum Frequency of 2 days – 2 weeks)

HEAT EXCHANGER TUBES (All Models)

Only Clean Heat Exchanger Tubes When Stove is Cool.

▪ Tube Scraper

After lifting the hopper lid, use the hole in the handle of the Grate Scraper Tool to “grab” onto the rod. Using the Grate Scraper Tool, pull the rod up and out towards the opening of the firebox. Continue pulling until the Tube Scraper reaches the top of the firebox. The rod is located on the outside, above the door. Pull the tube scraper rod out, then repeat 2–3 times to remove fly ash from the heat exchange tubes.

Tube Scraper

Use tool to grab scraper rod.

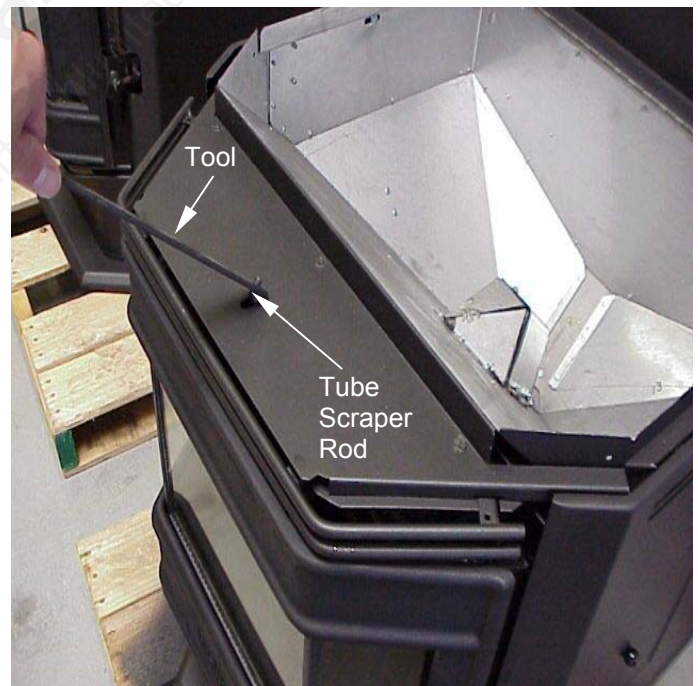

ROUTINE MAINTENANCE

Pull Scraper Rod out & in several times

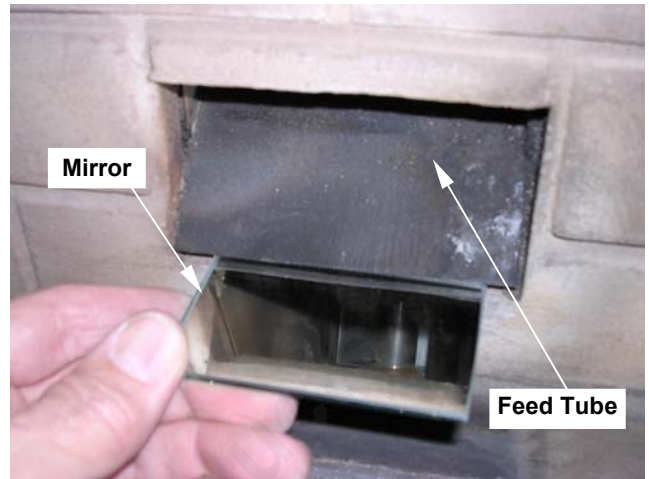

- Using a long soft bristled brush (i.e. artists brush), extend it deep into the feed chute and sweep away any pellet fines (on right side).
- Canned compressed air can also be used to remove pellet debris from the photoeye filter (use only canned compressed air such as what can be commonly purchased at a computer or office supply store and some drug stores). **Read and follow the instructions on the spray can.** Attach the tube (straw) to the nozzle on the canned air (a tube is commonly provided with compressed air. It is similar in use to the tube supplied with WD-40, Lubricant). Spray the canned air deep into the feed chute until all "fines" are removed (direct it to the right side).

REMOVABLE BAFFLE PLATES (All Models)

At least once a year, the baffle plates (located in the firebox below exchange tubes) should be removed for cleaning (vacuum out, then reinstall baffle plates)

Removing Baffle Plates

The baffle plates contain keyhole slots allowing the screws to remain in place while removing the baffle. Lift each plate up and forward until screws release through the keyhole slots. Remove baffle plates diagonally through door opening.

PHOTOEYE (Freestanding and Insert)

ENSURE STOVE/INSERT IS COLD BEFORE BEGINNING

As a part of normal maintenance, buildup of pellet debris (fines) must be periodically removed from the photoeye filter. This filter can be cleaned by following either procedure (A) or (B) on this page:

Note: The photoeye views the fire through a filter. The filter is located at the top of the feed chute near the hopper on the right side. This area should be cleaned periodically to prevent excessive build-up, which may cause the stove to go into "fault" mode.

(A) Cleaning Photoeye Filter Without Removing it:

- Open the front door to access the feed chute.
- Remove the buildup on the filter as explained in either "a" or "b" (note: it may help to use a mirror and a flashlight to view the filter as shown in the following picture):

NOTE: The photoeye lens should be inspected annually and cleaned if necessary as shown in method (B).

(B) Removing Photoeye Filter for Cleaning:

- Lift off cover plate and turn over (the photoeye is attached to the inside surface of cover). Wipe away any dust or debris from the photoeye lens (see following pictures).

Photoeye Access Inside Hopper

To access photoeye, open hopper and remove the 3 nuts on cover plate (see picture below).

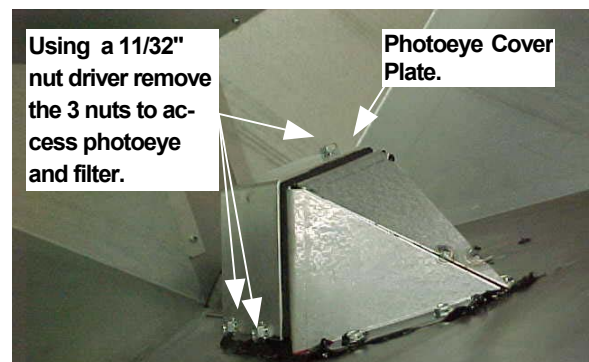

ROUTINE MAINTENANCE

Clean Photoeye Lens

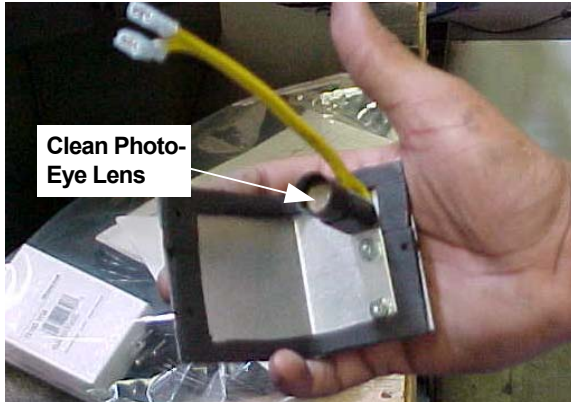

Remove Filter and Wipe Clean

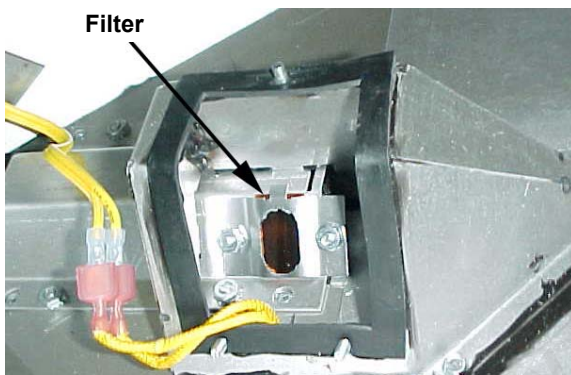

(Minimum frequency of 4 weeks - 6 months)

CAUTION: If the filter is not reinstalled, reflective light in the room may result in a fault, thus shutting down of the unit.

EXHAUST PASSAGES AND VENT PIPE (All Models)

Inspect frequently and clean when necessary. Fly ash will accumulate at all bends in the exhaust system.

Note: Large amounts of fly ash build-up will create a lack of combustion air. Removing the clean out tee cap on vertical installations will allow an inspection of the ash build-up in the clean out tee and will help you to decide how frequently more extensive cleaning must be performed.

Clean-Out Tee

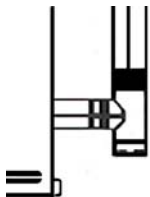

Rain Cap

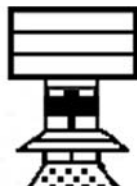

Clean-Out Tee

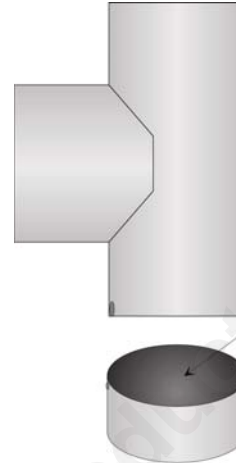

Remove cover, then remove ash

*(Minimum Frequency of 1-2 months)

ASH CLEAN-OUT PORTS

Make sure stove is cold. Ash clean-out ports must be cleaned as part of routine maintenance.

Accessing Clean-out Ports

Optima 3 Series (Firebrick panels must be removed to access):

IMPORTANT: Clean-out cover plates must be installed when operating unit.

Retainer Brackets



REMOVE RETAINER BRACKETS AND LIFT FIREBRICK PANELS UP AND OUT – Using a 5/16" nut driver, remove 2 screws in each firebrick retainer bracket (located on the sides of the inside firebox). Lift panels up and out.

REMOVE COVERS AND VACUUM OUT FLYASH - Loosen screws (1 per clean-out) and lift each plate out. Use an approved ash vacuum or brush to remove ash. After cleaning, replace clean-out plates and tighten screws.

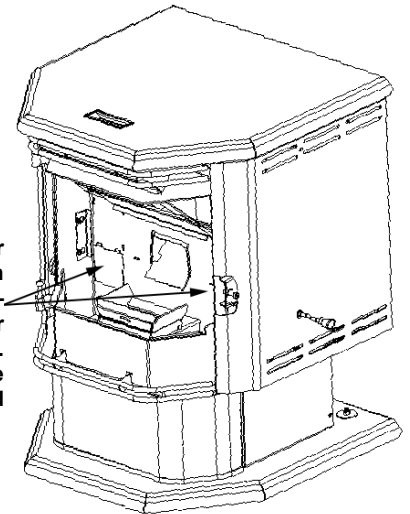

*(Minimum Frequency of 1-2 months)

ROUTINE MAINTENANCE

DOOR ROPE GASKET (All Models)

The condition of the rope gasket around the door and windows should be checked periodically and replaced or repaired if necessary. A one-inch strip of paper may be used to perform a test of the integrity of the door seal. Close the door on the paper in at least eight points (see illustration, "Door Rope Gasket"). It is normal to feel only a slight amount of friction. The door gasket does not need to be "tight" in all areas, since a small amount of leakage is not hazardous or detrimental to the performance of your stove.

Door Rope Gasket
(check seal at points indicated)



* (Minimum Frequency of 1 year)

Checking Door Seal



Important Note: Paper should be no longer than a dollar bill.

CREOSOTE REMOVAL (All Models)

When wood is burned slowly, it produces tar and other organic vapors, which combine with expelled moisture to form creosote. The creosote vapors condense in the relatively cool chimney flue of a slow-burning fire. As a result, creosote residue accumulates on the flue lining.

When ignited this creosote makes an extremely hot fire. The chimney connector and chimney should be inspected at least once every two months during the heating season to determine if a creosote buildup has occurred.

If creosote has accumulated it should be removed to reduce the risk of a chimney fire.

Window Wash

Periodically remove five screws, which secure the window wash bracket to the door frame, using a 1/4" socket. Lift out the window wash bracket, and set aside. Using a small brush, sweep out all debris buildup from behind the window wash bracket. After all debris has been removed re-attach the window wash bracket. Inspect the window wash gap to ensure that it is open and even from side to side. A restricted or blocked gap will decrease the effectiveness of the window wash.

Remove Window Wash Bracket (5 screws)



Sweep Away Debris from Behind Window Wash Bracket



* (Minimum Frequency of 1 year)

ROUTINE MAINTENANCE

SMALL AREA PAINT TOUCH-UP

The stove body is painted with a quality high-temperature stove paint. Use only model TSPK-B Stove Paint, Catalog # 70K99. Do not touch-up your stove with any other paint.

Using one small piece of 320 grit sand paper and lightly sand the blemish so that the edges are “feathered” or smooth to the touch between the painted and bare surfaces. Do not let the sand paper gum up with paint, as this will cause scratches on the metal surface. If there are any scratches, use 600 grit sandpaper instead. Mask off surfaces you do not want painted. Paint lightly over the bare surface first as this will act as an undercoat. Then paint over a larger area in smooth even strokes to blend.

REAR STOVE COMPARTMENT (All Models)

The rear stove compartment should be cleaned periodically (a minimum of once a year). DISCONNECT ELECTRICAL CORD PRIOR TO CLEANING STOVE. Any household dust, pet hair or sawdust should be vacuumed or wiped out of the rear compartment of the stove, room air blower, and exhaust blower (paying special attention to vacuuming out the intakes of both blowers). The electrical components should be wiped clean.

MOTOR LUBRICATION

The blowers are permanently lubricated by the manufacturer. Do not apply oil to any part of the blower, doing so may cause damage.

Opening Side Panels Optima 2 FS and Optima 3 FS

Using a 11/32” nut driver remove the nut from the inside of the hopper on the side (see following picture). Reinstall nut to prevent panel from opening accidentally!

Optima 2 FS and Optima 3 FS Opening Side Panels



SPECIFICATIONS - Optima 2 FS

Flue Size	3" / 76mm Rear
Width, Overall	23" / 584mm
Depth, Overall	22 3/4" / 578mm
Depth, Overall w / 3" tee	28 1/2" / 724mm
Height	28 5/8" / 727mm
Floor to Rear Flue Center	11 1/4" / 286mm
Facing back of unit, outside edge of left side to center of rear flue outlet center	6 1/2" / 165mm
Floor to Rear Outside Air Inlet Located on center-line of pedestal back	5" / 127mm
Facing back of Unit outside edge of right side to center of air inlet	11 1/2" / 292mm
Floor Protection Requirements	+ Front and Sides: 6"/152mm Back: Up to 6" / 152mm
Standard Features	Fastfire Self Igniter Wall Thermostat (wire included)
Hopper Capacity	55 lbs.
Burn time	◆ 15-37 hours
Fuse, Control Board Fuse, Igniter	5 Amp, 250 volt, 3AG * 6 Amp, 125 volt *
Heat Input (BTU's per hour) Overall Efficiency	◆ 13,000-32,000 BTU / hr 75-81%
Emissions	◆ 0.4 gr / hr (varies w/size and type of fuel) EPA exempt.
Shipping Weight	215 lbs.
Room Air Blower	150 CFM; .8 Amps, 2175 rpm
Auger Motor	1 RPM; .4 Amps
Exhaust Blower	95 CFM: 1.0 Amps, 2880 rpm
Fastfire Igniter	4.35 Amps,
Options	Nickel or Gold Trim Kits 4" Quick Disconnect Log Set

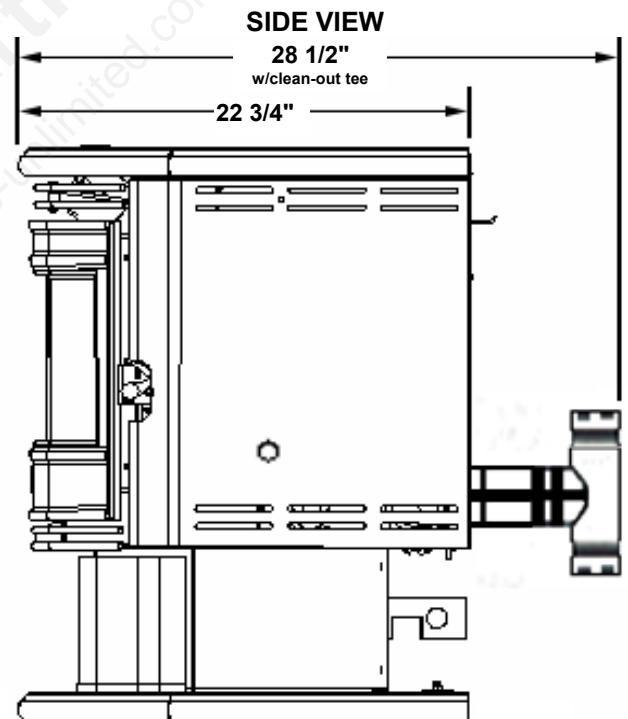
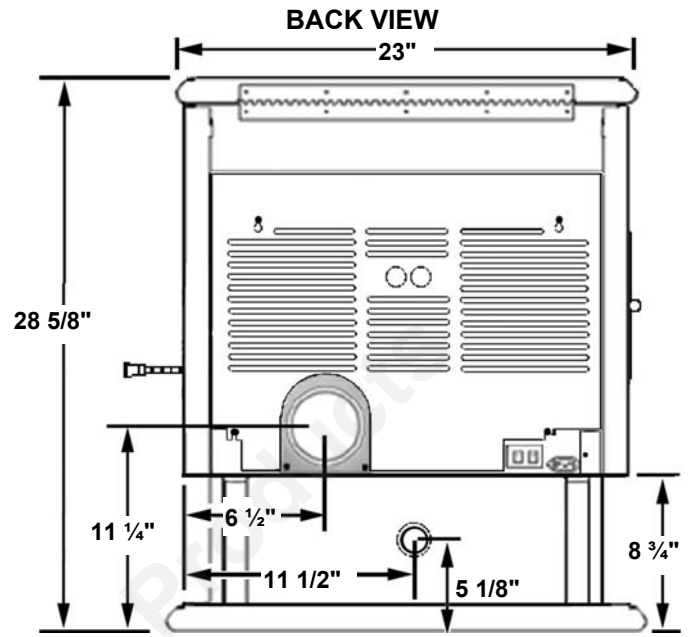

Note: Dimensions shown are approximations only (+/- 1/4")

+ **Non-combustible floor protection is required (see *Floor Protection*, page 5). When installed at clearances less than 6", the floor protector is only required to extend to the wall.**

◆ **Fuel delivery and burn times will vary depending on size and type of fuel used. Estimated heat input based on fuel value of 8400 BTU per lb.**

* **Fuses are rated as fast blow.**

SPECIFICATIONS - Optima 3 FS

Flue Size	3" / 76mm Rear
Width, Overall	25 7/8"
Depth, Overall	24 7/8"
Depth, Overall w / 3" tee	30 3/4"
Height	31 3/8"
Floor to Rear Flue Center	16 7/8"
Facing Back of Unit, outside edge on right to center of rear flue outlet	5 1/8"
Floor to Rear Outside Air Inlet Located on center- line of pedestal back.	10"
Facing Back of Unit outside edge on right to center of air inlet	12 15/16"
Floor Protection Requirements	+ Front and Side: 6"/152mm Back: Up to 6" / 152mm
Standard Features	Fastfire Self Igniter Wall Thermostat (wire included)
Hopper Capacity	70 lbs.
Burn time	◆ 16-41 hours
Fuse, Control Board Fuse, Igniter	5 Amp, 250 volt, 3AG * 6 Amp, 125 volt *
Heat Input (Max.) Overall Efficiency	◆ 14,000-38,000 BTU / hr 81%
Emissions	◆ .9 gr / hr (varies w / size and type of fuel) EPA ex- empt
Ship Weight	270 lbs.
Room Air Blower	150 CFM; .8 Amps, 2175 rpm
Auger Motor	1 RPM; .4 Amps
Exhaust Blower	95 CFM: 1.0 Amps, 2880 rpm
Fastfire Igniter	4.35 Amps,
Options	Nickel or Gold Trim Kits 4" Quick Disconnect Log Set

BACK VIEW

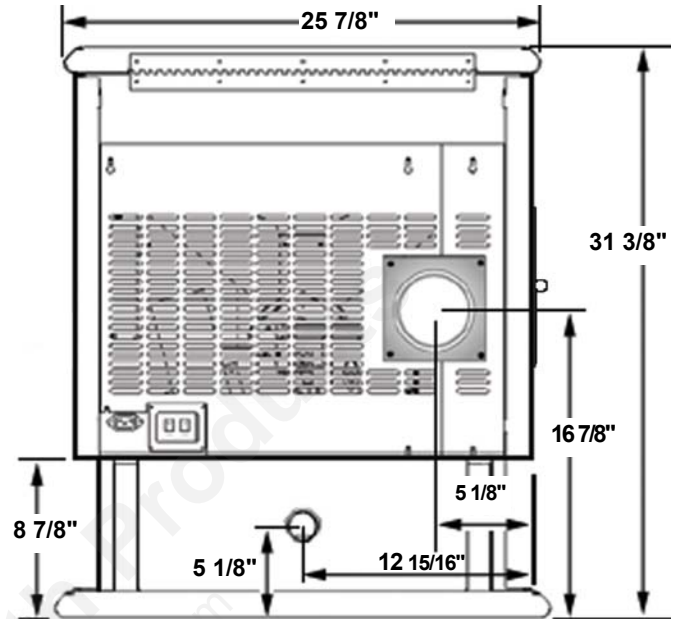

SIDE VIEW

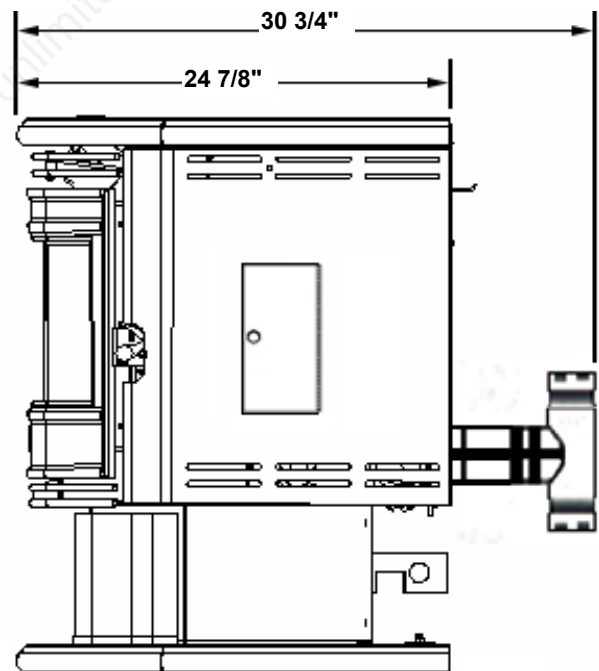

Note: Dimensions shown are approximations only (+/- 1/4")

+ **Non-combustible thermal rated floor protection must be used when installed on carpet (see *Floor Protection*, page 6). When installed at clearances less than 6", the floor protector is only required to extend to the wall.**

◆ **Fuel delivery and burn times will vary depending on size and type of fuel used. Estimated heat input based on fuel value of 8400 BTU per lb.**

* **Fuses are rated as fast blow.**

SPECIFICATIONS - Optima 3 INS

Flue Size	3" Rear
Width, Overall front (w/o surround)	26"
Width, Overall back (w/o surround)	24 1/8"
Depth, Overall (w/o surround)	26 1/4"
Height, rear (w/o surround)	19 15/16"
Height, front (w/o surround)	23 5/8"
Floor to Rear Flue Center	9 1/4"
Fireplace Face to Rear Flue Outlet Center (3" tee)	13 1/4"
Dimensions into Fireplace	
Minimum Height	20 1/8"
Minimum Width @ Front (extends back 1 1/2")	32"
Minimum Width @ Back	24 5/8"
Minimum Depth	17 3/4"
Facing Back of Unit, Right Outside Edge of Unit to Center of Rear Flue Outlet	5"
Floor to Rear Outside Air Inlet	1 1/2"
Facing Back of Unit, Right Outside Edge of Unit to Center of Air Inlet	12 7/16"
Floor Protection Requirements	Front: 6"
Standard Features	Fastfire Self Igniter Wall Thermostat (wire included)
Hopper Capacity	50 lbs.
Burn time	◆ 11-30 hours
Fuse, Control Board Fuse, Igniter	5 Amp, 250 volt, 3AG * 6 Amp, 125 volt *
Heat Input (Max.) Overall Efficiency	◆ 14,000-38,000 BTU / hr 81%
Emissions	◆ .9 gr / hr (varies w/size and type of fuel) EPA exempt.
Ship Weight	230 lbs.
Room Air Blower	150 CFM; .8 Amps, 2175 rpm
Auger Motor	1 RPM; .4 Amps
Exhaust Blower	95 CFM: 1.0 Amps, 2880 rpm
Fastfire Igniter	4.35 Amps
Options	Nickel or Gold Trim Kits 4" Quick Disconnect Log Set Sm./Med./Lg. Surrounds Gold Surround Trim Kits

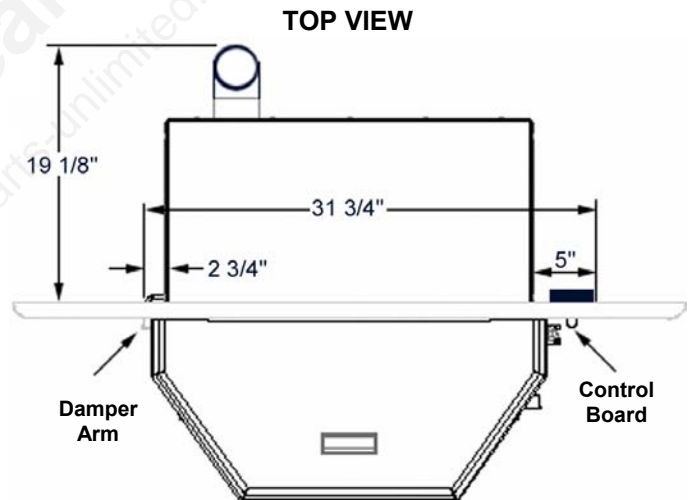
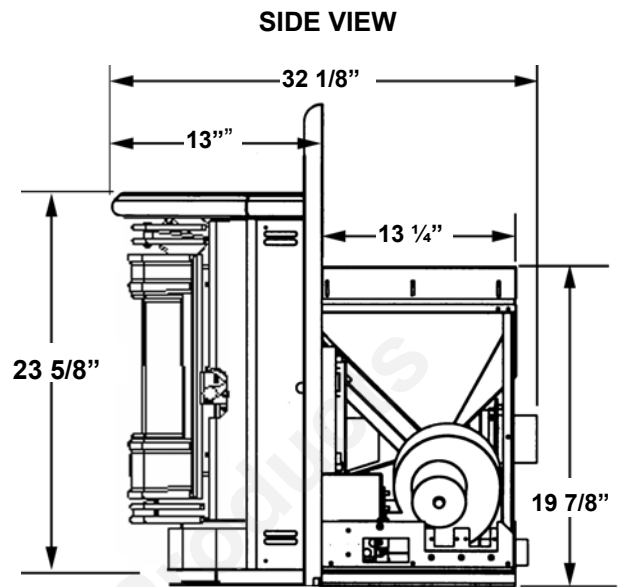

Note: Dimensions shown are approximations only (+/- 1/4")

+ Non-combustible floor protection must be used when installed on carpet (see *Floor Protection*, page 5).

◆ Fuel delivery and burn times will vary depending on size and type of fuel used. Estimated heat input based on fuel value of 8400 BTU per lb.

* Fuses are rated as fast blow

COMPONENT DEFINITIONS

AIR WASH

To inhibit buildup of soot on the door glass, air is delivered to the glass through an air wash system located in the doorframe surrounding the glass.

AUGER

It transfers the fuel down the burner tube into the burn grate.

AUGER MOTOR

Drives the Auger. Motor specifications are: .4 Amp, 1 rpm (revolutions per minute).

BLOWER, ROOM AIR (CONVECTION)

The blower function is to transfer the heat from the appliance to heat the room air.

BLOWER, EXHAUST (DRAFT INDUCER/COMBUSTION)

It has a radial impeller to deliver more air to the burn grate. It pulls air into the burn grate by creating a negative pressure. This is done by extracting the exhaust gases out of the firebox and pushing the exhaust downstream to the flue exit.

DISC, HIGH LIMIT (L250-30F, N / C)

There are 2 of these discs on this model. If a temperature reaches 250° F., the high limit auto reset will "trip" and stop the flow of electricity to the auger motor. The discs will not automatically reset until it has cooled below 220° F).

Disc for Room Air Blower – This disc is located on the Room Air Blower jacket and is designed to detect an overfire condition.

Disc for Combustion Air Inlet – This disc is located on the combustion air inlet and is designed to detect reversed flow. If negative pressure in the dwelling (i.e. An extremely tight house which may not supply adequate combustion and ventilation air) causes the exhaust to pull back from the combustion air inlet, the heat from the exhaust will result in heat activation of this disc.

HOPPER

The hopper is where the pellets are stored.

HEAT OUTPUT BUTTON

This is the main power button, which controls power to the feed system auger motor and exhaust blower. It has 3 feed rate settings, which controls the burn rate.

PHOTOEYE

The photoelectric eye that senses the flame, or lack of. It is designed to signal the control board to discontinue power to the auger motor if it flame is not sensed in the UltraGrate™.

PRESSURE SWITCH

A safety device used to shut off the feed system (auger motor) if there is too much back pressure in venting system. Some possible causes are as follows:

- ◆ The venting system is obstructed.
- ◆ High altitude or other misc. environmental conditions affecting exhaust flow.
- ◆ Improper venting system.

ULTRAGRATE™ (BURN GRATE)

This is where combustion occurs and may be referred to as the "burn grate".

WIRING DIAGRAM

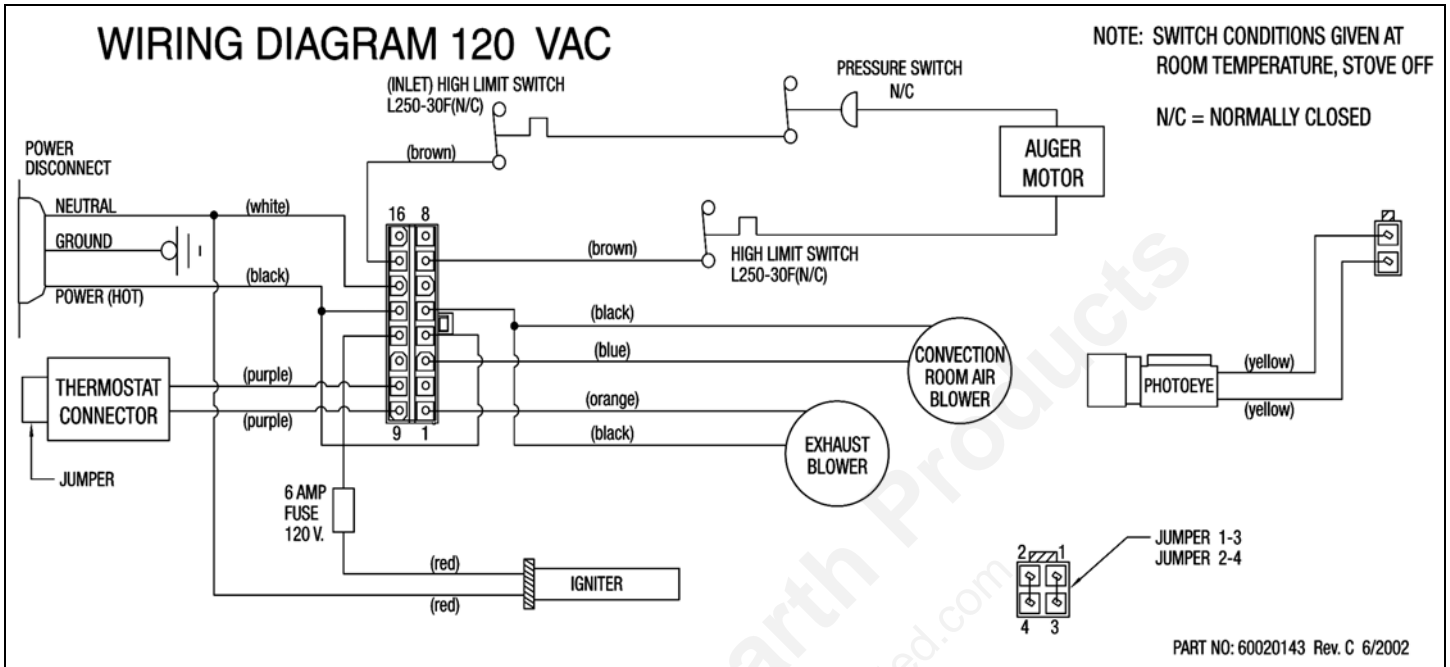

Terminal Block

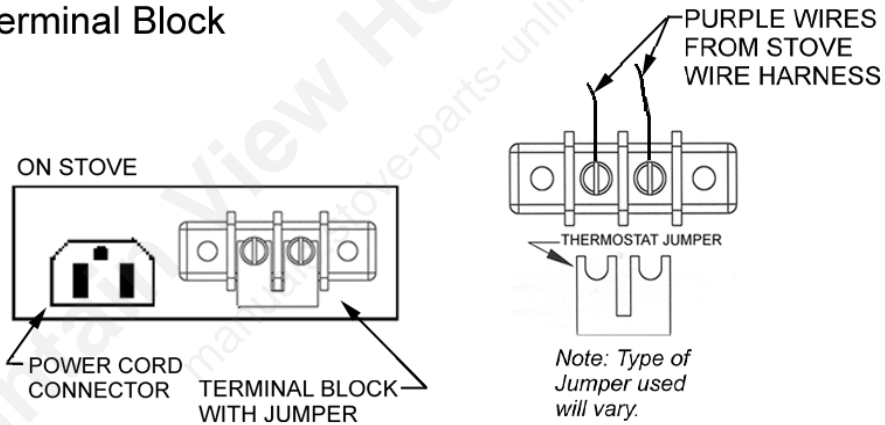

TROUBLESHOOTING Qualified Technicians Only
Unplug Appliance Before Performing Any Troubleshooting or Maintenance

PROBLEM	CAUSE(S)	SOLUTIONS
<p>1. Fire burns with a lazy orange flame. Pellets build up in the grate and there is excessive glass soot that is difficult to remove (Ash and soot are a product of combustion with any wood products, so some build-up on the glass is normal).</p>	<p>There is insufficient combustion air.</p>	<p>Lack of maintenance (clean Ultragrate™, clean-out ports, exhaust flow passages, venting system, exhaust blower intake, etc.)</p> <p>Remove any clinkers or ash from the bottom of the Ultragrate™ that might be obstructing the primary air holes.</p> <p>Check that the heat exchange tubes are not coated with ash.</p> <p>Clean internal exhaust ducts.</p> <p>Check gasket seal around the door. Use a thin strip of paper, 1 in. wide. Open the door and close it on the paper strip. A slight friction should be felt when the paper strip is pulled. Repeat this process at various locations around the door gasket. Replace the door gasket if necessary.</p> <p>Check gasket around ashpan.</p> <p>Check for blockage in the air inlet tube or exhaust pipe. Clean as Necessary.</p> <p>Inspect glass seal to ensure that it is in good condition and is properly seated to the door.</p> <p>Fuel trim may need to be adjusted down for faster feeding fuels.</p> <p>Change to a better grade of fuel if necessary.</p> <p>Check that the damper has been opened enough for the amount of fuel fed.</p> <p>Have Your Authorized Lennox Hearth Products dealer check your exhaust blower for proper operation.</p> <p>The venting system design is too restrictive (call your authorized Lennox Hearth Products Technician to evaluate how the installation can be corrected to satisfy the exhaust flow requirements of the appliance).</p>
<p>2. Fire goes out or stove shuts down automatically</p>	<p>Stove has run out of fuel.</p> <p>Pellets are not feeding.</p> <p>The high limit disc (thermal switch) has tripped.</p> <p>There is too much combustion air for the amount of fuel.</p>	<p>Refill hopper.</p> <p>See (Pellets will not feed) this page.</p> <p>Allow stove to cool for 1 hour and re-light. If the stove has been operating at a medium to high burn rate and the room air blower has been turned down low then the fan should be turned up higher. If this problem persists (particularly at lower burn rates) then the high limit disc should be replaced by your authorized dealer.</p> <p>Adjust the damper to reduce combustion air flow.</p>
<p>3. Pellets will not feed.</p>	<p>The hopper is empty.</p> <p>The auger motor or control board may be defective. The pressure switch tap or hose may be blocked.</p> <p>Back pressure in venting tripping pressure switch.</p> <p>Thermostat is in stand-by mode.</p> <p>Thermostat wires disconnect.</p> <p>High limit disc (thermal switch) may have been tripped.</p> <p>Self-aligning bearings in auger motor may be mis-aligned.</p>	<p>Refill hopper.</p> <p>Check to be sure that there is no blockage in the pressure tap or hose. Have your authorized Lennox Hearth Products dealer diagnose the problem and clean or replace any necessary parts.</p> <p>If new installation check for excessive 90° bends, long horizontal runs or excessive vertical run of 3" pipe. Possibly change to 4" pipe. If older installation check for excessive ash accumulation in pipe or other obstructions. Clean out pipe.</p> <p>Check to see if thermostat is set to low or if sun is shining directly on thermostat.</p> <p>Re-install wires.</p> <p>Allow stove to cool. Increase room air blower setting.</p> <p><u>Gently</u> tap the auger motor.</p>

TROUBLESHOOTING Qualified Technicians Only
Unplug Appliance Before Performing Any Troubleshooting or Maintenance

PROBLEM	CAUSE(S)	SOLUTIONS
4. Blowers will not operate when the start button is depressed.	There is no power to the stove. There is no power to the control board.	Check that the stove is plugged in to the wall outlet. Check to see if your circuit breaker has tripped. Check the wire connections on the high limit disc and control board.
5. There is soot or fly ash in the house.	The window is being cleaned when the stove is operating. There is leakage at the joints between the exhaust blower, connection or exhaust pipe connections. This will be evidenced by dust on the impeller of the room air blower, and in the heat exchanger area. The vacuum cleaner is leaking.	Turn down the room air blower or turn off stove before cleaning to prevent dispersion of ash and soot into the room. Seal up any leaks in the exhaust system with room temperature vulcanizing silicone sealer (High Temperature RTV). DO NOT use a standard household vacuum or "shop vac" as the filters will leak the fine particles of ash. Clean the stove with an approved ash vacuum ONLY.
6. Stove acts as if a fire is present when there is not a fire in the grate.	Excessive sun light may be shining directly into firebox from window.	Block excessive sunlight. Call authorized Lennox Hearth Products dealer if problem persists.
7. Stove will not light.	The igniter element may have failed. There is not enough pellets in the grate.	Check igniter element fuse in rear stove compartment. Call your authorized Lennox Hearth Products dealer. See alternate manual lighting procedure Prime the feed system (see <i>Initial Start-Up</i> , page 24).
8. Fault	Photoeye not detecting flame. Stove has run out of fuel. A disk has tripped / pressure switch.	Check connection at control board following yellow wires to all connectors. Refill hopper. Blower intake, exhaust passages and / or venting system needs cleaning (follow routine and annual maintenance procedures). If this does not correct the problem contact your local authorized Lennox Hearth Products dealer.
9. Blowers run continuously	Wire harness and/or control board has been damaged – unplug stove and contact dealer.	Contact your local authorized Lennox Hearth Products dealer.
10. All lights on control are on but nothing happens	When using a thermostat. Thermostat not calling for heat. If not using a thermostat - Check thermostat jumper	The lights on the control board remain on even when the thermostat is not demanding heat. When the thermostat demands heat the stove will begin to operate. Ensure that the thermostat jumper at terminal block is installed and making good contact.

TROUBLESHOOTING *Qualified Technicians Only*
Unplug Appliance Before Performing Any Troubleshooting or Maintenance

Troubleshooting Notes for Qualified Technicians only:

- 1.) If a 'tri-ac' (switching device within the controls) is blown for a particular component, it is possible for that component to run continuously. The 'tri-ac' can be blown due to excessive heat or a voltage spike in excess of the specified +/- 10% of line voltage (120v).
- 2.) Many nuisance 'faults' can be avoided by properly 'breaking-in' the stove. It is strongly recommended that the stove be run on the 'high' setting until 4 – 8 bags of fuel have been consumed. The auger / feed system will loosen up during this period and begin to feed at a slightly faster rate which may have an impact during the 'start-up' routine.
- 3.) The igniter works by forcing air from the convection (room air) blower, through 2 holes in the igniter tube, and passing over the hot igniter probe. This hot air is what causes the pellets to ignite. It is very important that the convection jacket is properly sealed with high temperature RTV High Temperature Silicone (all seams and penetrations). If there are enough leaks, the igniter will not receive enough air to promote ignition. It is also very important that the holes in the igniter tube (located just inside the room air blower convection jacket) not become filled with RTV High Temperature Silicone. Ignition will not occur if these holes are blocked.

REPLACEMENT PARTS LIST

Door Parts & Body Components

Item #	Part No. / Cat. No.	Description	Stove Model
2	14650460	Door Assembly, Cast Iron Firebox	Optima 2 FS
2	14750458	Door Assembly, Cast Iron Firebox	Optima 3 FS & INS
	15051547	Gasket Kit, Door, 3/4" Rope, (8 Ft.)	Optima 2 FS
	61051000	Gasket Kit, Door, 1" Rope, (7 Ft.)	Optima 3 FS & INS
	61057202	Gasket Kit, Glass (5/8" x 1/16" x 10 Ft.)	All
	H0257	• Glass, Front	Optima 2 FS
	H0258	• Glass, Side (order 2 if set is needed)	Optima 2 FS
	H0254	• Glass, Front	Optima 3 FS & INS
	H0255	• Glass, Side (order 2 if set is needed)	Optima 3 FS & INS
3	14750406	Knob Kit, Door (includes latch, 3 washers, nut and door latch receiver)	All
4	14750405	Opener, Door Handle	All
5	14650446	Hinge Bracket	Optima 2 FS
6	14750700	Hinge Bracket	Optima 3 FS & INS
7	14650450	Panel, Left Side	Optima 2 FS
8	14650451	Panel, Right Side	Optima 2 FS
9	14750449	Panel, Left Side	Optima 3 FS
10	14750448	Panel, Right Side	Optima 3 FS
11	14650456	Panel, Rear	Optima 2 FS
12	14750465	Panel, Rear	Optima 3 FS
13	14750612	Panel, Left Side	Optima 3 INS
14	14750613	Panel, Right Side	Optima 3 INS
15	14750617	Panel, Top (hopper lid)	Optima 3 INS
16	14650455	Panel, Top (hopper lid)	Optima 2 FS
16	14750455	Panel, Top (hopper lid)	Optima 3 FS
	12051409	Knob, Control Panel Door (6 per package w/studs)	Optima 3 INS

• Includes gasket.

Electrical Parts

Item #	Part #	Description	Stove Model
17	12046300	Auger Motor	All
27	12050011	Blower Assembly, Exhaust	All
	12056011	Blower Motor, Exhaust	All
28	12146109	* Blower, Room air, Hard Washer	All
18	16053941	Control Board	Optima 2 FS
18	16052112	Control Board	Optima 3 FS & INS
19	12147705	Disc, High Limit, 250 DG (L250-30F,60T21) Set of 3	All
	18150150	Fuse, Control Board, 5 Amp, 250 volt, Fast blow, 12 pk.	All
	12055908	Fuse, Igniter, 6 Amp, 125 volt, Fast blow, 12 pk.	All
20	12150213	Igniter Assembly, Replacement, 380 Watts, 3.3 Amp.'s, 1 each (includes fuse holder w/fuse)	All
22	14750404	Photoeye Kit, Replacement	All
23	12058820	Power Cord, 8 feet	All
25	16050001	Pressure Switch	All
24	16050205	Thermostat, Wall (wire not included)	All
26	12050815	Wiring Harness	All

REPLACEMENT PARTS LIST

Firebox Parts

Item #	Part #	Description	Stove Model
29	13640028	Clips, Brick	Optima 2 FS
30	11750011	Clips, Brick	Optima 3 FS & INS
31	14650011	Firebrick Set, 1 pc.	Optima 2 FS
32	14750015	Firebrick Set, 3 pc.	Optima 3 FS & INS
33	14650428	Housing, Igniter Tube	Optima 2 FS
34	14750421	Housing, Igniter Tube	Optima 3 FS & INS
35	12158905	UltraGrate™	All

Auger System Components

Item #	Part #	Description	Stove Model
37	12041300	Collar & Screw Set, Auger (Set of 3)	All
38	20950088	Flange, Auger	All
39	17150009	Scraper Rod Assembly	Optima 2 FS
39	14750410	Scraper Rod Assembly	Optima 3 FS & INS
40	11756300	Shaft, Auger	All

Misc.

Item #	Part #	Description	Stove Model
	14650408	Ash Pan	Optima 2 FS
	14750409	Ash Pan	Optima 3 FS
	14750603	Ash Pan	Optima 3 INS
	12151308	Plate, Damper	Optima 2 FS & Optima 3 FS
41	15050058	Filter, Photoeye	All
	14650060	Gasket, Photoeye	Optima 2 FS
	14750060	Gasket, Photoeye	Optima 3 FS & INS
42	61050003	Gasket, Auger Flange, 5pc.	All
43	61050005	Gasket, Exhaust blower, 5pc.	All
44	61057203	Gasket, Room air blower, 5pc.	All
45	61050016	Gasket, Quick Disconnect 5pc.	All
	12151307	Setscrew, Damper Rod (Set of 6)	Optima 2 FS & Optima 3 FS
46	12055500	Tool, Grate Scraper	All
47	12050093	Quick Disconnect 3" Vent Side	All

* Includes gasket and four nuts.

2

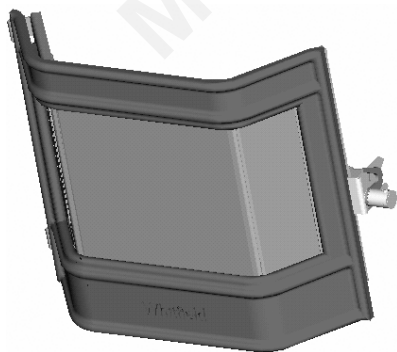

3

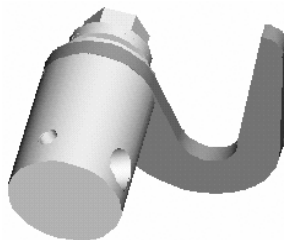

4

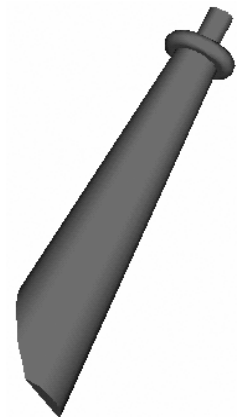

REPLACEMENT PARTS DIAGRAMS

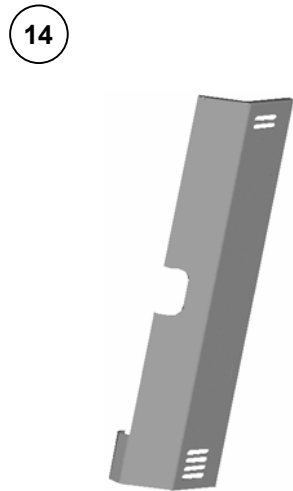
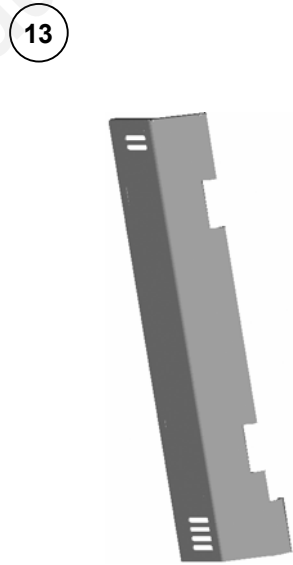
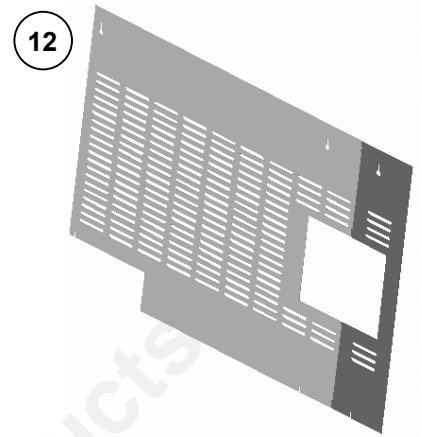
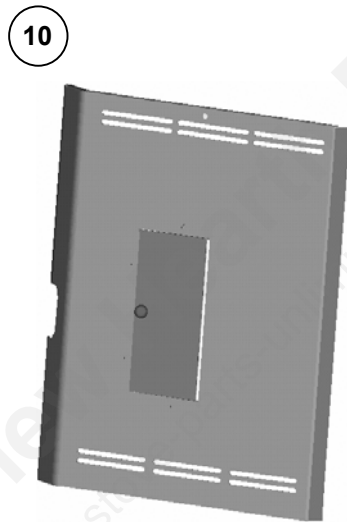
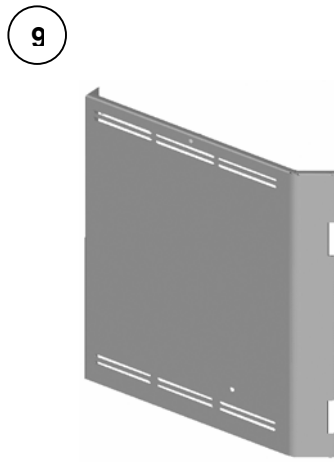
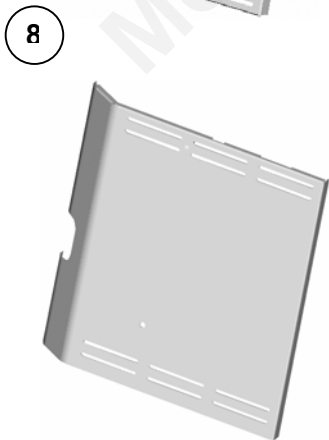
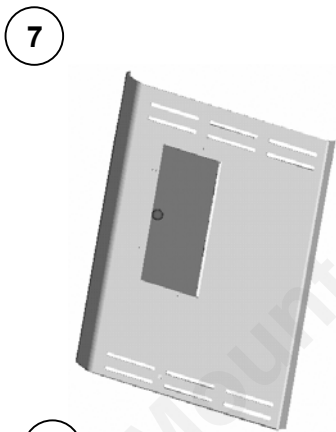
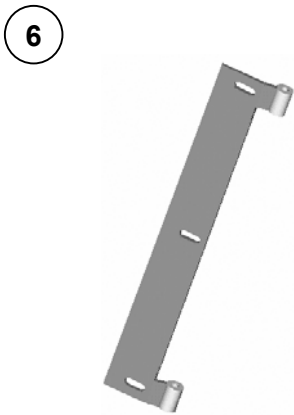
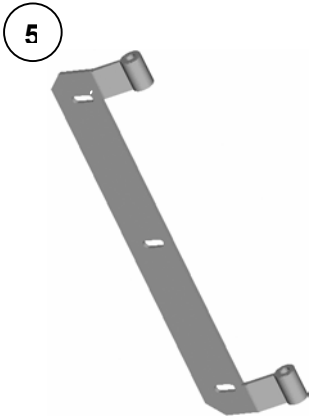

REPLACEMENT PARTS DIAGRAMS

15

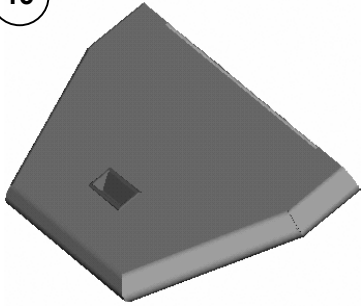

16

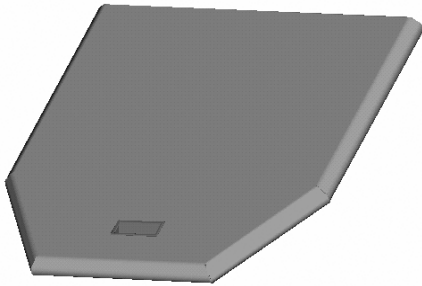

17

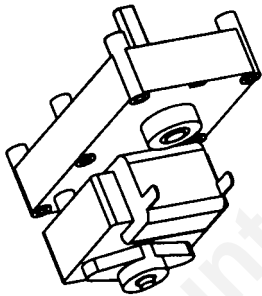

18

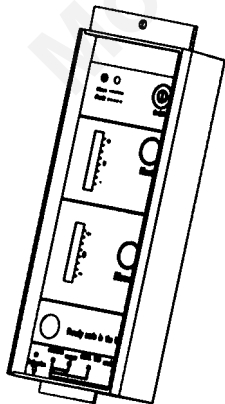

19

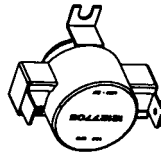

20

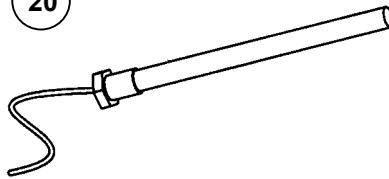

22

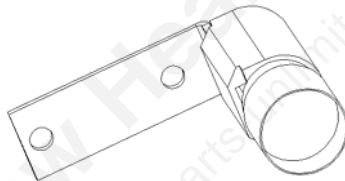

23

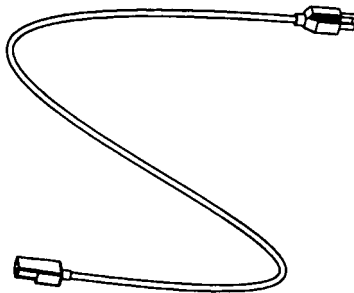

24

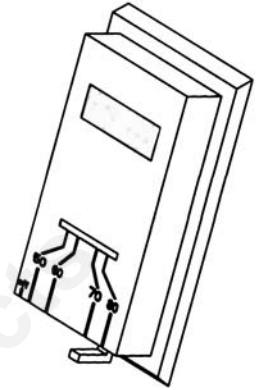

25

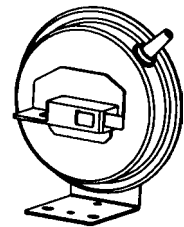

26

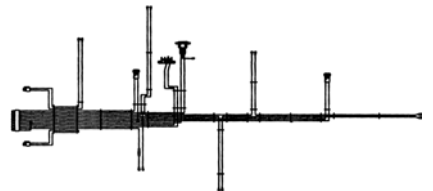

27

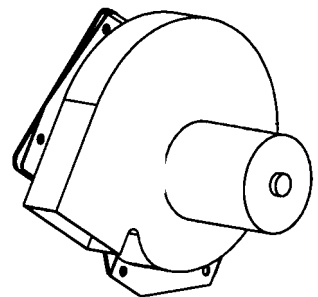

REPLACEMENT PARTS DIAGRAMS

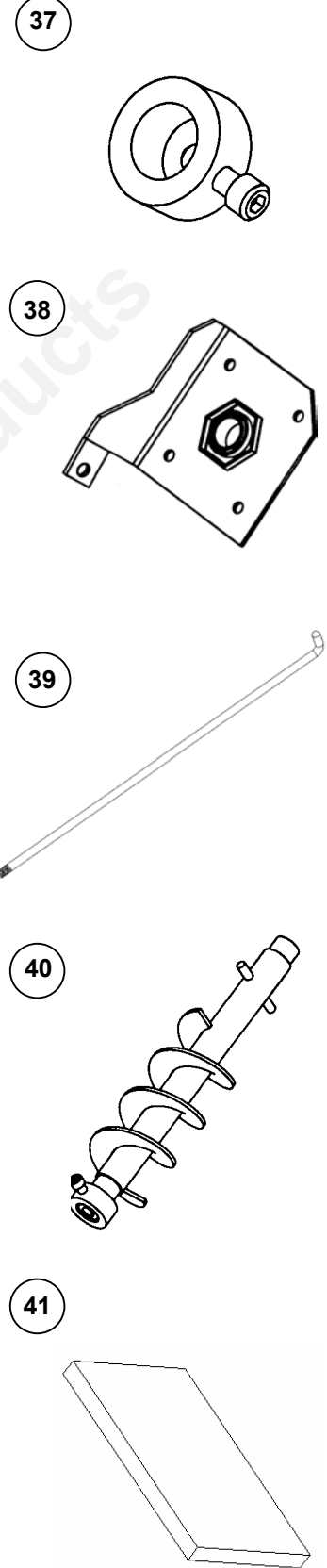
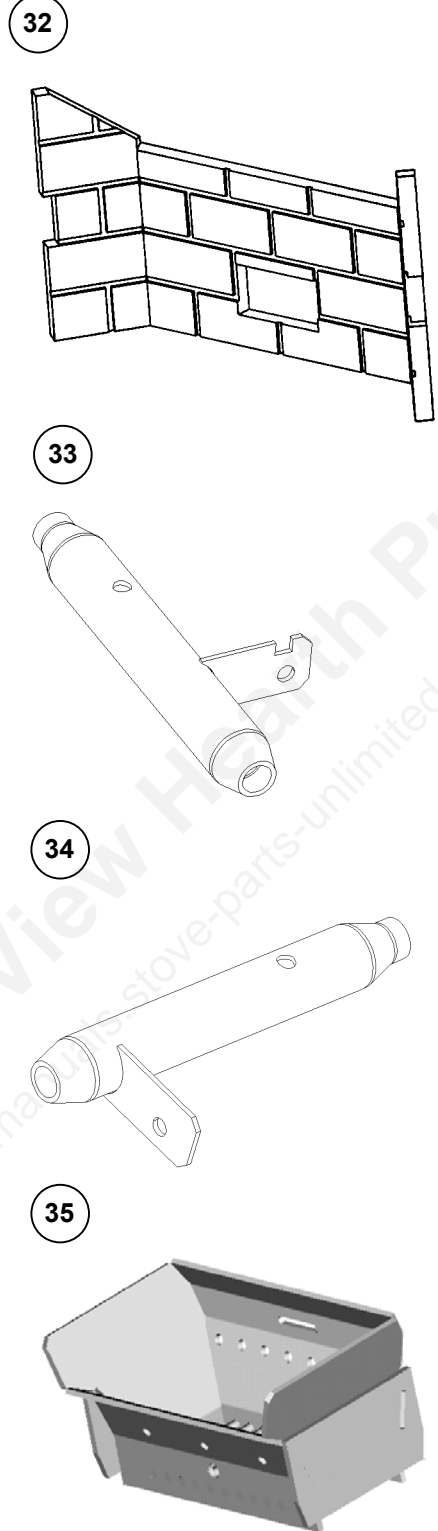
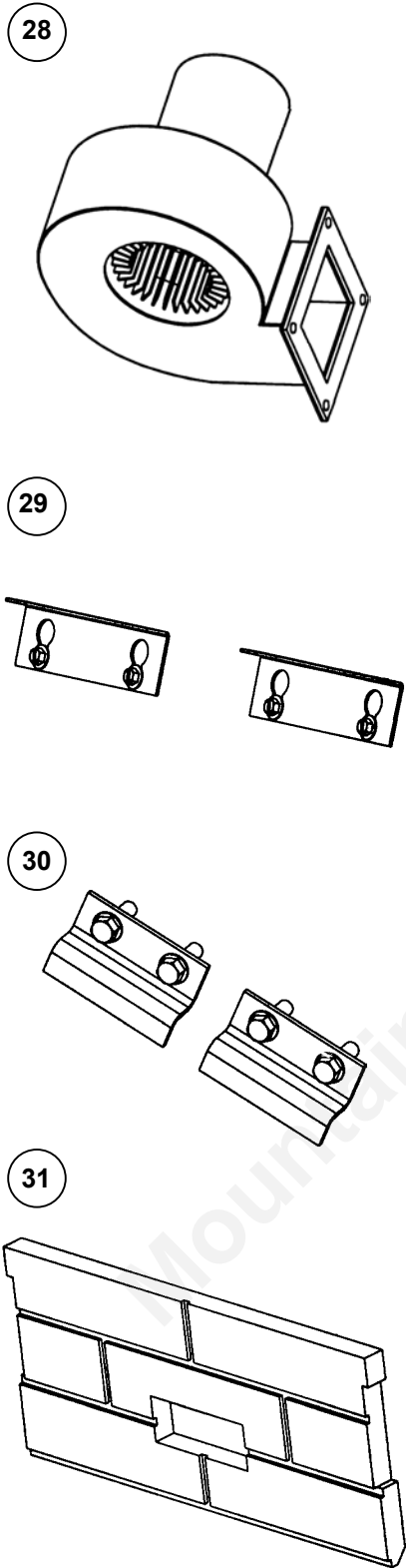

REPLACEMENT PARTS DIAGRAMS

42

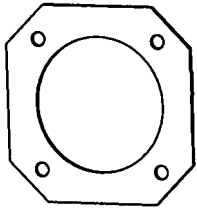

44

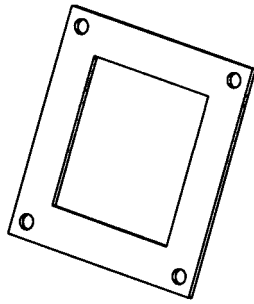

46

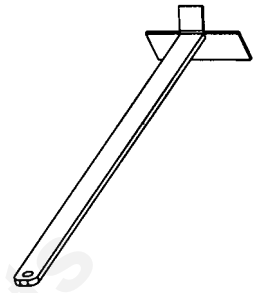

43

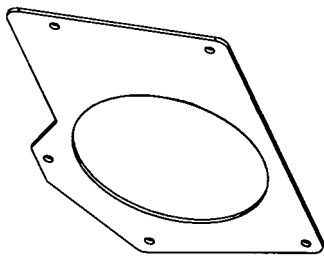

45

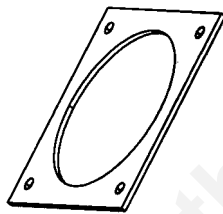

47

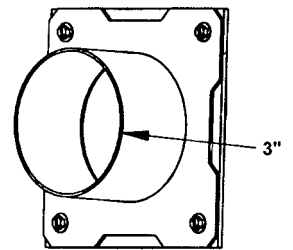

Mountain View Hearth Products
manuals.stove-parts-unlimited.com

OPTIONAL ACCESSORIES DIAGRAMS

Optional Accessories

Item #	Part #	Model	Description	Stove Model
1	H0448	TKAO2-G	Trim Kit, AO2 Gold	Optima 2 FS
1	H0449	TKAO2-N	Trim Kit, AO2 Nickel	Optima 2 FS
1	H0450	TKAO3-G	Trim Kit, AO3 Gold	Optima 3 FS & INS
1	H0451	TKAO3-N	Trim Kit, AO3 Nickel	Optima 3 FS & INS
2	14M81	QDPC-4	Quick Disconnect Pipe Connector, 4"	All
	70K99	TSPK-B	Touch-up Spray Paint Kit, Black	All
3	H0442	SKSAO3	Surround Kit, Small, 30 1/2" x 40 3/4", Black	Optima 3 INS
3	H0443	SKMAO3	Surround Kit, Medium, 34" x 44", Black	Optima 3 INS
3	H0444	SKLAO3	Surround Kit, Large, 38 x 48", Black	Optima 3 INS
4	H0445	STKSAO3	Surround Trim Kit, Small, 30 1/2" x 40 3/4", Gold	Optima 3 INS
4	H0446	STKMAO3	Surround Trim Kit, Medium, 34" x 44", Gold	Optima 3 INS
4	H0447	STKLAO3	Surround Trim Kit, Large, 38 x 48", Gold	Optima 3 INS
5	H0244	DLS-P	Decorative Log Set, Pellet	Optima 2 FS
6	H0464	DLS-AO3	Decorative Log Set	Optima 3 Series
7	H0432	HEK-AO3	Hearth Extension Kit	Optima 3 INS
	H0416	ZCK-PI	Zero Clearance Kit (for installing insert as a built-in)	Optima 3 INS

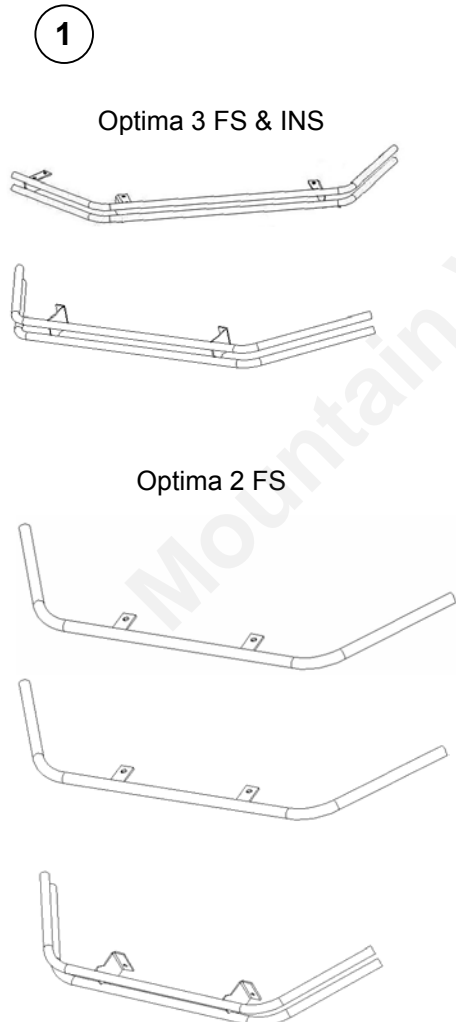

Converts from standard 3" outlet to 4"

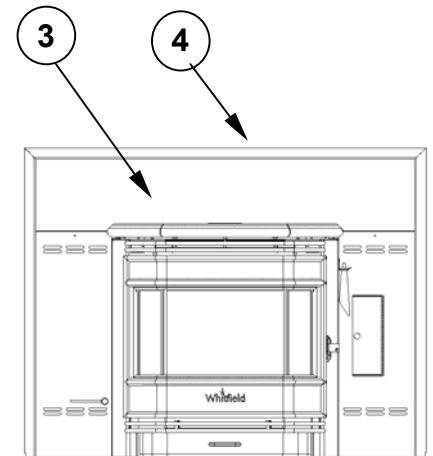
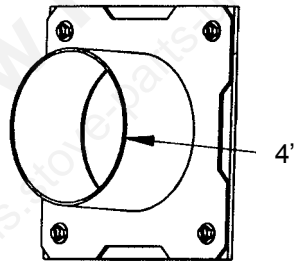

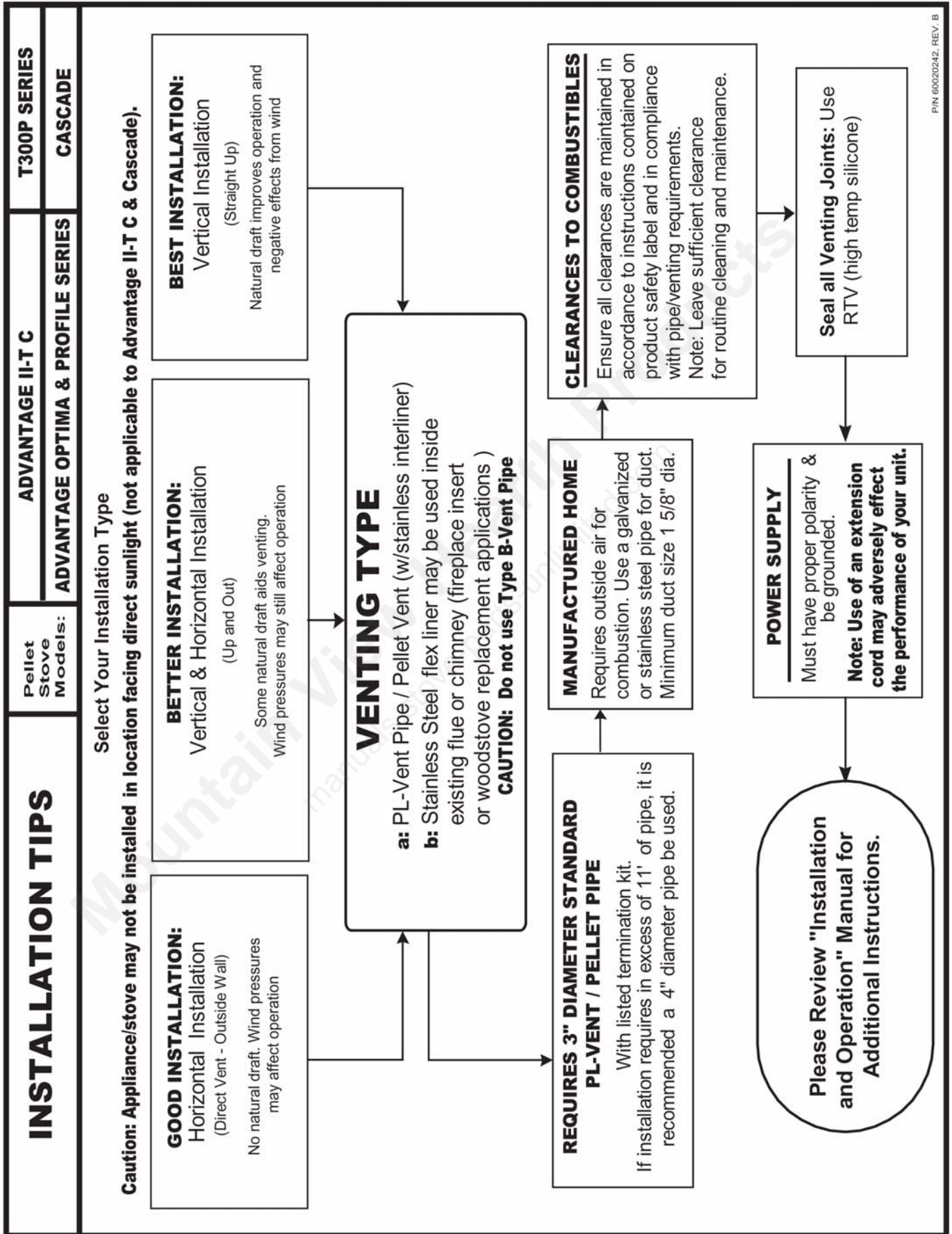

SIMPLE OPERATING INSTRUCTIONS LABEL

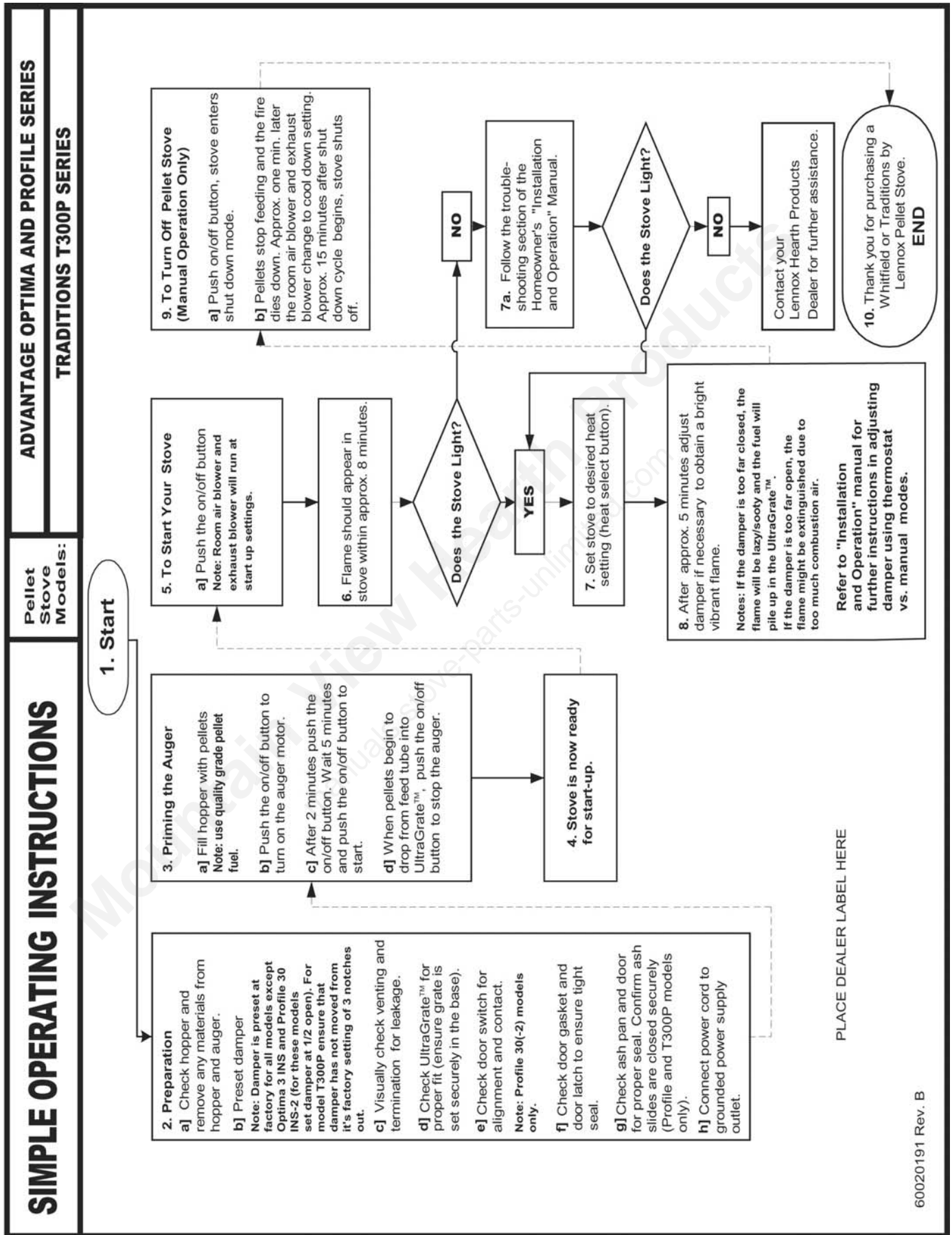

SAFETY/LISTING LABEL – Model Optima 2 FS

Note that your stove's serial number is printed on the safety label, which is located near the inside of the hopper. Your stove's serial number is preceded by a "WH-"(Example WH-000000).



CERTIFIED FOR U.S. AND CANADA. LISTED ROOM HEATER FOR USE WITH APFI/FFI APPROVED PELLETIZED WOOD FUEL ONLY. FOR USE IN MANUFACTURED (MOBILE) HOMES, AND AS AN INSERT FOR MASONRY AND FACTORY BUILT FIREPLACES. **MODEL: OPTIMA 2** TESTED TO ASTM E-1509 / UL 1482 / ULC-S627 / ULC-S628 REPORT NO. 6658 (JULY 1993).

INSTALL AND USE ONLY IN ACCORDANCE WITH THE MANUFACTURER'S INSTALLATION INSTRUCTIONS. CONTACT LOCAL BUILDING OR FIRE OFFICIALS ABOUT RESTRICTIONS AND INSTALLATION INSPECTION IN YOUR AREA. DO NOT CONNECT THIS UNIT TO A CHIMNEY FLUE SERVING ANOTHER APPLIANCE. SEE LOCAL BUILDING CODE AND MANUFACTURER'S INSTRUCTIONS FOR PRECAUTIONS REQUIRED FOR PASSING A CHIMNEY THROUGH A COMBUSTIBLE WALL OR CEILING. THIS PELLET FIRED APPLIANCE HAS BEEN TESTED AND LISTED FOR USE IN MANUFACTURED HOMES IN ACCORDANCE WITH OREGON ADMINISTRATIVE RULES 814-23-900 THROUGH 814-23-909.

OPERATE ONLY WITH FIREBRICK IN PLACE. WARNING: OPERATE ONLY WITH VIEWING DOOR CLOSED. INSPECT FLUE FREQUENTLY TO PREVENT ACCUMULATION OF SOOT. THE HEATER AND FLUE MUST BE IN GOOD CONDITION. KEEP FURNISHINGS AND OTHER COMBUSTIBLE MATERIALS WELL AWAY FROM HEATER.

NUMÉRO DE SÉRIE / SERIAL NO.

WH-



CAUTION: HOT SURFACES WHILE IN OPERATION. DO NOT TOUCH. CONTACT MAY CAUSE SKIN BURNS.

KEEP CHILDREN, COMBUSTIBLE MATERIAL AND FURNISHINGS A CONSIDERABLE DISTANCE AWAY. SEE NAMEPLACE AND INSTRUCTIONS. TYPE OF FUEL: PELLETIZED WOOD FUEL ONLY.

MINIMUM CLEARANCES TO COMBUSTIBLE MATERIALS

FREESTANDING STOVE INSTALLATION	MANUFACTURED (MOBILE) HOME OR RESIDENTIAL INSTALLATION	
	HORIZONTAL FLUE-DIRECTLY THROUGH WALL INSTALLATION	INTERIOR VERTICAL FLUE INSTALLATION
SIDEWALL TO UNIT	A* 4" / 102 MM	4" / 102 MM
BACKWALL TO UNIT	B 1" / 25 MM	9" / 229 MM
WALL TO UNIT CORNER	C 1" / 25 MM	1" / 25 MM
ALCOVE TO FUEL HOPPER	D 4" / 102 MM	4" / 102 MM
MAX. DEPTH OF ALCOVE	E 24" / 610 MM	24" / 610 MM
FLUE TO WALL	F 3" / 77 MM	3" / 77 MM
FRONT/REAR/SIDE TO FLOOR PROTECTION OUTSIDE EDGE	I 6" / 153 MM	6" / 153 MM

Optima 2

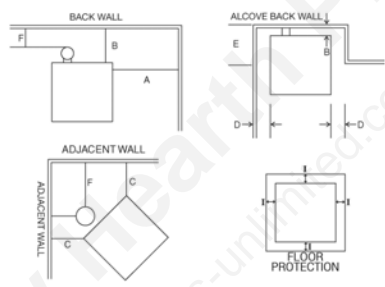

ROUTINE MAINTENANCE REMINDER

FREQUENCY OF CLEANING AND MAINTENANCE OF YOUR STOVE DEPENDS ON THE ASH CONTENT OF THE PELLETS YOU BURN. CHECK THE FOLLOWING PARTS OF YOUR STOVE WEEKLY FOR THE FIRST MONTH TO DETERMINE THE FREQUENCY OF CLEANING.

- A. BURN GRATE
- B. HEAT EXCHANGER TUBES
- C. ASH PAN AND EXHAUST PIPE

SEE YOUR MANUAL AND/OR DEALER FOR MORE INFORMATION.
INPUT RATING RANGE: 1.5 TO 3.8 LBS./HOUR (NOMINAL)
ELECTRICAL RATING: 60 HZ, 115 V, LESS THAN 10 AMP

DO NOT REMOVE THIS LABEL



6 00205 02 R E V A

WHITFIELD
BY LENNOX HEARTH PRODUCTS

Manufactured by:
Lennox Hearth Products
1110 West Taft Avenue
Orange, CA 92865



ATTENTION : SURFACES CHAUDES DURANT LE FONCTIONNEMENT DE L'APPAREIL. NE PAS TOUCHER. UN CONTACT PEUT CAUSER DES BRÛLURES CUTANÉES. TENIR LES ENFANTS, LES MATÉRIAUX COMBUSTIBLES ET L'AMEUBLEMENT À UNE DISTANCE CONSIDÉRABLE DE L'APPAREIL. VOIR LA PLAQUE SIGNALÉTIQUE ET LES DIRECTIVES. TYPE DE CHAUFFAGE : BOIS DE CHAUFFAGE GRANULÉ SEULEMENT.

NE PAS ENLEVER CETTE ÉTIQUETTE DÉGAGEMENT MINIMUM POUR LES MATÉRIAUX COMBUSTIBLES

INSTALLATION DU POÈLE AUTONOME	INSTALLATION RES DENTIELLE OU DANS UNE MAISON PRÉFABR QUÉE (MOBILE)	INSTALLATION NTERIEURE DU CONDUIT DE FUMÉE A LA VERTICALE
DU MUR LATÉRAL À L'APPAREIL	A 4 po/102 MM	4 po/102 MM
DU MUR ARRIÈRE À L'APPAREIL	B 1 po/25 MM	9 po/229 MM
DU MUR AU COIN DE L'APPAREIL DE L'ALCÔVE À L'ENTONNOIR DU BOIS DE CHAUFFAGE	C 1 po/25 MM	1 po/25 MM
PROFONDEUR MAX DE L'ALCÔVE DU CONDUIT DE FUMÉE AU MUR DE L'AVANT, L'ARRIÈRE ET LES CÔTÉS AU PLANCHER BORD EXTÉRIEUR DE PROTECTION	D 4 po/102 MM E 24 po/610 MM F 3 po/77 MM	4 po/102 MM 24 po/610 MM 3 po/77 MM
	I 6 po/153 MM	6 po/153 MM

Optima 2

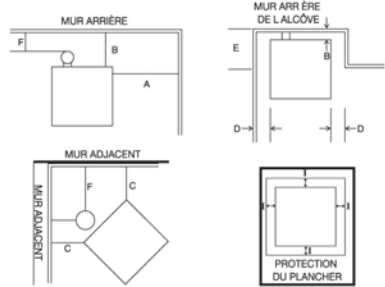

RAPPEL D'ENTRETIEN PÉRIODIQUE

LA FRÉQUENCE DU NETTOYAGE ET DE L'ENTRETIEN DE VOTRE POÈLE DÉPEND DE LA QUANTITÉ DE CENDRES BRÛLÉES PAR LES GRANULÉS. VÉRIFIER TOUTES LES SEMAINES LES PIÈCES SUIVANTES DE VOTRE POÈLE POUR LE PREMIER MOIS POUR DÉTERMINER LA FRÉQUENCE DE NETTOYAGE.

- A. GRILLE
- B. TUBES D'ÉCHANGEUR DE CHALEUR
- C. CONTENANT DE CENDRES ET TUYAU D'ÉCHAPPEMENT

CONSULTER VOTRE GUIDE OU VOTRE DÉTAILLANT POUR OBTENIR PLUS D'INFORMATION.
CONSUMMATION THERMIQUE : 1,5 À 3,8 LB/HEURE (NOMINAL)
CARACTÉRISTIQUES ÉLECTRIQUES : 60 HZ, 115 V, MOINS DE 10 A

DO NOT REMOVE THIS LABEL

WHITFIELD
BY LENNOX HEARTH PRODUCTS

Fabriqué par:
Lennox Hearth Products
1110 West Taft Avenue
Orange, CA 92865

SAFETY/LISTING LABEL – Model Optima 3 FS and Optima 3 INS

Note that your stove's serial number is printed on the safety label, which is located near the inside of the hopper. Your stove's serial number is preceded by a "WH-" (Example WH-000000).

Warnock Hersey
C H US

LISTED ROOM HEATER. PELLETIZED WOOD FUEL TYPE. ALSO FOR USE IN MANUFACTURED (MOBILE) HOME, AND AS AN INSERT FOR MASONRY FIREPLACES AND FACTORY BUILT FIREPLACES, OR AS BUILT IN. MODEL: OPTIMA 3, TESTED TO: UL 1482 / ULC-S627 / ULC-S628 REPORT NO: 5515 (DEC. 1991) ASTM E1509 REPORT NO: 476-1244 (MAR. 1996).

INSTALL AND USE ONLY IN ACCORDANCE WITH THE MANUFACTURER'S INSTALLATION INSTRUCTIONS. CONTACT LOCAL BUILDING OR FIRE OFFICIALS ABOUT RESTRICTIONS AND INSTALLATION INSPECTION IN YOUR AREA. DO NOT CONNECT THIS UNIT TO A CHIMNEY FLUE SERVING ANOTHER FIREPLACE. SEE LOCAL BUILDING CODE AND MANUFACTURER'S INSTRUCTIONS FOR PRECAUTIONS REQUIRED FOR PASSING A CHIMNEY THROUGH A COMBUSTIBLE WALL OR CEILING. THIS PELLET FUEL APPLIANCE HAS BEEN TESTED AND LISTED FOR USE IN MANUFACTURED (MOBILE) HOMES IN ACCORDANCE WITH OREGON ADMINISTRATIVE RULES 814-23-900 THROUGH 814-23-909.

OPERATE ONLY WITH FIREBRICKS IN PLACE. OPERATE ONLY WITH VIEWING DOOR AND ASH REMOVAL DOOR CLOSED. INSPECT FLUE FREQUENTLY. CLEAN HEAT EXCHANGER AND FLUE FREQUENTLY TO PREVENT ACCUMULATION OF SOOT. THE HEATER AND FLUE MUST BE IN GOOD CONDITION. REQUIRED COMPONENTS: DAMPER SEALING PLATE FOR INSERT INSTALLATIONS. USE 3" / 75MM OR 4" / 100MM MODEL PL CHIMNEY COMPONENTS. KEEP FURNISHINGS AND OTHER COMBUSTIBLE MATERIALS WELL AWAY FROM HEATER.

ELECTRICAL RATING: 115V 60Hz Less than 10 Amp
FUEL INPUT RATING: 4.5 lbs./Hr. Max.

ROUTINE MAINTENANCE REMINDER

FREQUENCY OF CLEANING AND MAINTENANCE OF YOUR STOVE DEPENDS ON THE ASH CONTENT OF THE PELLETS YOU BURN. CHECK THE FOLLOWING PARTS OF YOUR STOVE WEEKLY FOR THE FIRST MONTH TO DETERMINE CLEANING:

- A. BURN GRATE
- B. HEAT EXCHANGER TUBES
- C. ASH TRAPS AND ASHPAN

SEE YOUR MANUAL AND/DEALER FOR MORE INFORMATION.

Warnock Hersey
C H US

RÉPERTOIRE COMME RADIATEUR IND VIDUEL. FONCTIONNE AU BOIS DE CHAUFFAGE GRANULÉ. PEUT AUSSI ÊTRE UTILISÉ DANS LES MAISONS PRÉFABRIQUÉES (MOBILES), COMME FOYER ENCASTRABLE DANS DES FOYERS DE MAÇONNERIE ET FABRIQUÉS EN USINE OU COMME MODÈLE INTÉGRÉ. OPTIMA 3, MIS À L'ÉPREUVE SELON LES NORMES SUIVANTES : UL 1482/ULC-S627/ULC-S628, NO DE RAPPORT : 5515 (DÉC. 1991) ASTM E1509, NO DE RAPPORT : 476-1244 (MARS 1996).

INSTALLER L'APPAREIL ET NE L'UTILISER QU'EN CONFORMITÉ AVEC LES DIRECTIVES D'INSTALLATION DU FABRICANT. COMMUNIQUER AVEC LES AUTORITÉS COMPÉTENTES LOCALES EN MATIÈRE DE BÂTIMENT ET D'INCENDIE POUR EN SAVOIR PLUS SUR LES RESTRICTIONS ET L'INSPECTION DE L'INSTALLATION DANS VOTRE RÉGION. NE RACCORDER PAS CET APPAREIL À UN CONDUIT DE FUMÉE DESSERVANT UN AUTRE FOYER. CONSULTER LE CODE DU BÂTIMENT LOCAL ET LES DIRECTIVES DU FABRICANT POUR CONNAÎTRE LES MESURES DE PRÉCAUTIONS À PRENDRE POUR PASSER UNE CHEMINÉE DANS UN MUR OU UN PLAFOND. CET APPAREIL ALIMENTE AUX GRANULES A ÉTÉ MIS À L'ÉPREUVE ET EST RÉPERTOIRÉ POUR UNE UTILISATION DANS DES MAISONS PRÉFABRIQUÉES (MOBILES) CONFORMÉMENT AUX RÈGLEMENTS ADMIN STRATIFS DE L'OREGON, DE 814-23-900 À 814-23-909.

FAIRE FONCTIONNER L'APPAREIL UNIQUEMENT SI DES BRIQUES RÉFRACTAIRES SONT EN PLACE. NE FAIRE FONCTIONNER QUE SI LA PORTE VITRÉE ET LA PORTE DE RETRAIT DES CENDRES SONT FERMÉES. INSPECTER FRÉQUEMMENT LE CONDUIT DE FUMÉE. NETTOYER FRÉQUEMMENT L'ÉCHANGEUR DE CHALEUR ET LE CONDUIT DE FUMÉE AFIN D'ÉVITER UNE ACCUMULATION DE SUIE. LE RADIATEUR ET LE CONDUIT DE FUMÉE DOIVENT ÊTRE EN BON ÉTAT. COMPOSANTS REQUIS : PLAQUE D'ÉTANCHÉITÉ DE REGISTRE POUR L'INSTALLATION DE FOYER ENCASTRABLE. UTILISER DES COMPOSANTS DE CHEMINÉE PL DE 3 po/75 mm OU de 4 po/100 mm. TENIR L'AMEUBLEMENT ET LES MATÉRIELS COMBUSTIBLES LOIN DE L'APPAREIL.

CARACTÉRISTIQUES ÉLECTRIQUES : 115 V, 60 Hz, moins de 10 A
CONSOMMATION THERMIQUE : 4,5 lb/h Max.

RAPPEL D'ENTRETIEN PÉRIODIQUE

LA FRÉQUENCE DU NETTOYAGE ET DE L'ENTRETIEN DE VOTRE POÊLE DÉPEND DE LA QUANTITÉ DE CENDRES BRÛLÉES PAR LES GRANULES. VÉRIFIER TOUTES LES SEMAINES LES PIÈCES SUIVANTES DE VOTRE POÊLE POUR LE PREMIER MOIS AFIN DE DÉTERMINER LA FRÉQUENCE DE NETTOYAGE :

- A. GRILLE
- B. TUBES D'ÉCHANGEUR DE CHALEUR
- C. TRAPPES ET CONTENANT DES CENDRES

CONSULTER VOTRE GUIDE ET VOTRE DÉTAILLANT POUR OBTENIR PLUS D'INFORMATION.

DO NOT REMOVE THIS LABEL

NUMÉRO DE SÉRIÉ/SERIAL WH-

MINIMUM CLEARANCES TO COMBUSTIBLE MATERIALS

INSTALLED AS FREESTANDING STOVE	MANUFACTURED MOBILE HOME OR RESIDENTIAL INSTALLATION	
	HORIZONTAL FLUE-DIRECTLY THROUGH WALL INSTALLATION	INTERIOR VERTICAL FLUE INSTALLATION
SIDEWALL TO UNIT	A 6"/153 MM	6"/153 MM
BACKWALL TO UNIT	B 1"/26 MM	9"/229 MM
CORNER TO UNIT	C 1"/26 MM	1"/26 MM
ALCOVE TO FUEL HOPPER	D 6"/153 MM	6"/153 MM
DEPTH OF ALCOVE	E 16"/407 MM	N/A
FLUE TO WALL	F 3"/77 MM	3"/77 MM

COMBUSTIBLE FLOOR MUST BE PROTECTED BY A 3/8" (10MM) MINIMUM MILLBOARD OR EQUIVALENT NON-COMBUSTIBLE MATERIAL IN THE USA AND CANADA EXTENDING BENEATH THE HEATER AND TO THE FRONT AND SIDES AS INDICATED OR TO THE NEAREST PERMITTED COMBUSTIBLE MATERIAL (6'-6" / 150MM).

INSTALLED AS AN INSERT

USE 3"/75MM / MODEL PL CHIMNEY COMPONENTS OR LISTED SINGLE WALL CHIMNEY LINER. SEAL THE AREA BETWEEN THE FIREPLACE DAMPER AND THE INSERT FLUE. MAY BE INSTALLED IN A MASONRY FIREPLACE THAT MEETS NATIONAL AND LOCAL BUILDING CODE REQUIREMENTS. (UBC 37 OR ULC S628) DO NOT REMOVE BRICKS OR MORTAR. MAY BE INSTALLED IN A FACTORY BUILT FIREPLACE. (UL 127 OR ULC S610) DO NOT ALTER OR MODIFY THE FIREPLACE. REFER TO OWNERS MANUAL FOR SPECIFIC INSTALLATION REQUIREMENTS. DO NOT ROUTE CORD BENEATH OR OVER APPLIANCE. THE INSERT MODEL MAY BE FRAMED INTO A WALL USING ZERO CLEARANCE KIT. CAT. NO. H0416.

60020503 REV NC

NE PAS ENLEVER CETTE ÉTIQUETTE

INSTALLÉ COMME POÊLE AUTONOME	DÉGAGEMENT MINIMUM POUR LES MATÉRIELS COMBUSTIBLES		
	INSTALLATION RÉG DENTELLE OU DANS UNE MAISON PRÉFABRIQUÉE (MOBILE)	INSTALLATION DU CONDUIT DE FUMÉE À L'HORIZONALE, DIRECTEMENT DANS LE MUR.	INSTALLATION DU CONDUIT DE FUMÉE À LA VERTICALE
DU MUR LATÉRAL À L'APPAREIL	A 6 po/153 MM	6 po/153 MM	6 po/153 MM
DU MUR ARRIÈRE À L'APPAREIL	B 1 po/26 MM	1 po/26 MM	9 po/229 MM
DU CORN À L'APPAREIL	C 1 po/26 MM	1 po/26 MM	1 po/26 MM
DE L'ALCÔVE À L'ENTONNOIR OU BOIS DE CHAUFFAGE	D 6 po/153 MM	6 po/153 MM	6 po/153 MM
PROFONDEUR DE L'ALCÔVE OU CONDUIT DE FUMÉE AU MUR	E 16 po/407 MM	16 po/407 MM	N/A
	F 3 po/77 MM	3 po/77 MM	3 po/77 MM

LE PLANCHER SUR LEQUEL REPOSE L'APPAREIL DOIT ÊTRE PROTÉGÉ PAR UN CELLODÈME D'AU MOINS 3/8 po (10 MM) OU PAR UN MATÉRIEL NON COMBUSTIBLE ÉQUIVALENT AUPÈS U ET AU CANADA. LE MATÉRIEL DOIT COUVRIR LA PARTIE SOUS L'APPAREIL ET LA PARTIE AVANT AINSI QUE LES CÔTÉS SELON LES INDICATIONS DONNÉES OU JUSQU'À L'ENDROIT PERMIS LE PLUS PRÈS POUR LES MATÉRIELS COMBUSTIBLES (6'-6 po/150 MM).

INSTALLÉ COMME UN FOYER ENCASTRABLE

UTILISER DES COMPOSANTS DE CHEMINÉE PL DE 3 po/75 mm OU UNE DOUBLURE DE CHEMINÉE MURALE SIMPLE. SCELLER L'ENDROIT SITUÉ ENTRE LE REGISTRE DU FOYER ET LE CONDUIT DE FUMÉE DU FOYER ENCASTRABLE. PEUT ÊTRE INSTALLÉ DANS UN FOYER DE MAÇONNERIE QUI EST CONFORME AUX RÈGLEMENTS DU CODE DU BÂTIMENT LOCAL ET NATIONAL. (UBC 37 OR ULC S628) NE PAS ENLEVER LES BRIQUES OU LE MORTIER. PEUT ÊTRE INSTALLÉ DANS UN FOYER FABRIQUÉ EN USINE. (UL 127 OR ULC S610) NE PAS ALTERER OU MODIFIER LE FOYER. CONSULTER LE GUIDE DU PROPRIÉTAIRE POUR CONNAÎTRE LES EXIGENCES PRÉCISES D'INSTALLATION. NE PAS ACHÉMINER LE CORDON SOUS L'APPAREIL, OU AU-DESSUS DE CELUI-CI. LE FOYER ENCASTRABLE PEUT ÊTRE ENCADRÉ DANS UN MUR À LAIDE DU NECESSAIRE SANS DÉGAGEMENT. NO DE CAT. H0416.

CAUTION: HOT SURFACES WHILE IN OPERATION. DO NOT TOUCH. CONTACT MAY CAUSE SKIN BURNS. KEEP CHILDREN, COMBUSTIBLE MATERIAL AND FURNISHINGS A CONSIDERABLE DISTANCE AWAY. SEE NAMEPLATE AND INSTRUCTIONS. TYPE OF FUEL: PELLETIZED WOOD FUEL ONLY.

OPTIMA 3

Warnock Hersey
C H US

Whitfield
BY LENNOX HEARTH PRODUCTS

Manufactured by:
Lennox Hearth Products
1110 West Taft Avenue
Orange, CA 92865

ATTENTION : SURFACES CHAUDES DURANT LE FONCTIONNEMENT DE L'APPAREIL. NE PAS TOUCHER. UN CONTACT PEUT CAUSER DES BRÛLURES CUTANÉES. TENIR LES ENFANTS, LES MATÉRIELS COMBUSTIBLES ET L'AMEUBLEMENT À UNE DISTANCE CONSIDÉRABLE DE L'APPAREIL. CONSULTER LA PLAQUE SIGNALÉTIQUE ET LES DIRECTIVES. TYPE DE CHAUFFAGE : BOIS DE CHAUFFAGE GRANULÉ SEULEMENT.

OPTIMA 3

Warnock Hersey
C H US

Whitfield
BY LENNOX HEARTH PRODUCTS

Fabriqué par:
Lennox Hearth Products
1110 West Taft Avenue
Orange, CA 92865

MODEL : Optima 3
NUMÉRO DE SÉRIÉ/SERIAL NO.

See safety label on Hopper side panel for detailed information

Consulter l'étiquette de sécurité située sur le panneau latéral de l'entonnoir pour obtenir de l'information détaillée

OWNERSHIP RECORDS

Dealer's Name:

Dealer's Address:

City:	State:	Zip Code:
-------	--------	-----------

Serial Number:	Date of Purchase:	Date Installed:
----------------	-------------------	-----------------

Notes:

SERVICE AND MAINTENANCE LOG

Service Date	Service Technician	Service Description
--------------	--------------------	---------------------

--	--	--

--	--	--

--	--	--

--	--	--

--	--	--

--	--	--

--	--	--

--	--	--

--	--	--

--	--	--

--	--	--

--	--	--

--	--	--

--	--	--

--	--	--

--	--	--

--	--	--

--	--	--

--	--	--

--	--	--

--	--	--

--	--	--

Mountain View Hearth Products
manuals.stove-parts-unlimited.com

LENNOX[®]

HEARTH PRODUCTS
1110 West Taft Avenue
Orange, CA 92865