



INSTALLATION AND OPERATION MANUAL

**FREESTANDING
PELLET FIRED
STOVES**



www.nficertified.org

We suggest that our pellet hearth products be installed and serviced by professionals who are certified in the U.S. by the National Fireplace Institute® (NFI) as NFI Pellet Specialists or who are certified in Canada by Wood Energy Technical Training (WETT).



**Wood Energy
Technical Training**
www.wettinc.ca

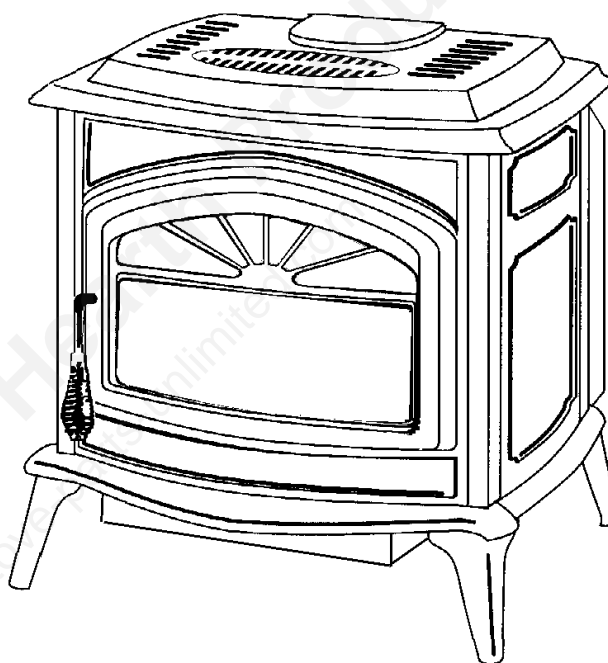

**RETAIN THESE
INSTRUCTIONS
FOR FUTURE
REFERENCE**

**Freestanding Model
T300P Series**

These appliances must be properly installed and operated in order to prevent the possibility of a house fire. Please read this entire owner's manual before installing and using your pellet stove. Failure to follow these instructions could result in property damage, bodily injury or even death. Contact your local building or fire officials to obtain a permit and information on any installation requirements and inspection requirements in your area.



P/N 775025M, Rev. E, 12/03

IMPORTANT WARNINGS

CAUTION: Read this manual thoroughly before starting installation. For your safety, follow the installation, operation and maintenance instructions exactly without deviation. Failure to follow these instructions may result in a possible fire hazard and will void the warranty. If this appliance is not properly installed, a house fire may result. Contact local building or fire officials about restrictions and installation inspection in your area.

- 1. DO NOT CONNECT THIS UNIT TO A CHIMNEY FLUE CONNECTED TO ANOTHER APPLIANCE.**
- 2. Do not connect this appliance to air ducts or any air distribution system.**
- 3. Do not install a flue damper in the exhaust venting system of this appliance.**
- 4. Do not use class B venting intended for gas appliances as a chimney or connector pipe on a pellet-fired appliance.**
- 5. The minimum clearances must be maintained for all combustible surfaces and materials including; furniture, carpet, drapes, clothing, wood, papers, etc. Do not store firewood within this clearance space.**
- 6. INSTALLATION DISCLAIMER - This stoves exhaust system works with negative combustion chamber pressure and a slightly positive chimney pressure. Therefore, it is imperative that the exhaust system is gas tight and installed correctly. Since Lennox Hearth Products has no control over the installation of your stove, Lennox Hearth Products grants no warranty, implied or stated for the installation or maintenance of your stove, and assumes no responsibility for any consequential damage(s).**
- 7. Burning any kind of fuel consumes oxygen. If outside air is not ducted to the appliance, ensure that there is an adequate source of fresh air available to the room where the appliance is installed.**
- 8. This stove is not intended for use in commercial installations other than where the stove is being sold without prior approval from Lennox Hearth Products.**
- 9. The stove will not operate using natural draft, nor without a power source for the blower and fuel feeding systems.**
- 10. Never use gasoline, gasoline-type lantern fuel, kerosene, charcoal lighter fluid, or similar liquids to start or "freshen up" a fire in this heater. Keep all such liquids well away from the heater while it is in use.**
- 11. CONTINUOUS OPERATION: When operated correctly, this appliance cannot be overfired. Continuous operation at a maximum burn can, however, shorten the life of the electrical components (blowers, motors, and electronic controls), and is not recommended. Typical approved operation would include running at the low to mid range setting with occasional running on the maximum setting during the coldest periods of the winter. The blower speed control should be turned to high when operating the stove on the high heat setting.**
- 12. CAUTION: NEVER PUT FINGERS NEAR AUGER. Pellet fuel is fed to the UltraGrate™ by a screw auger. This auger is driven by a high torque motor. The auger is capable of doing serious harm to fingers. Keep pellets in the hopper at all times and keep fingers away from auger. The auger can start and stop automatically at any time while the stove is running.**
- 13. CAUTION: HOT WHILE IN OPERATION. An appliance hot enough to warm your home can severely burn anyone touching it. Keep children, clothing and furniture away. Contact may cause skin burns. Do not let children touch the appliance. Train them to stay a safe distance from the unit.**
- 14. APPROVED FUEL: This appliance is designed specifically for use only with pelletized wood fuels only. With its advanced UltraGrate™ technology, this appliance is designed and approved for the burning of wood residue pellets with up to 3% ash content. This appliance is NOT approved to burn cardboard, nut hulls, cherry pits, corn, etc. regardless if it is in pellet form. Failure to comply with this restriction will void all warranties and the safety listing of the stove. Consult with your authorized Lennox Hearth Products dealer for more information on approved pellet fuels.**
- 15. FLY ASH BUILD-UP: For all wood pellet fuel-burning heaters, the combustion gases will contain small particles of fly ash. This will vary due to the ash content of the fuel being burned. Over time, the fly ash will collect in the exhaust venting system and restrict the flow of the flue gases. The exhaust venting system should be inspected regularly and cleaned as necessary.**
- 16. SOOT FORMATION Incomplete combustion, such as occurs during startup, shutdown, or incorrect operation of the room heater will lead to some soot formation which will collect in the exhaust venting system. A precautionary inspection on a regular basis is advisable to determine the necessity of cleaning. The exhaust venting system should be inspected regularly and cleaned as necessary.**
- 17. DISPOSING OF ASHES: Any ashes removed from the pellet stove must be deposited in a metal container with a tight-fitting lid. The closed container of ashes should be placed on a noncombustible floor or on the ground, well away from all combustible materials, outside of the dwelling pending final disposal. If the ashes are disposed of by burial in soil or otherwise locally dispersed, they should be retained in the closed container until all cinders have been thoroughly cooled.**
- 18. SAVE THESE INSTRUCTIONS.**
- 19. See the listing label on the stove body (or see Safety / Listing Label, page 38).**

TABLE OF CONTENTS

Important Warnings	2
Testing / Listing, EPA, Using this Manual.....	3
Planning Your Installation	4-6
Manufactured (Mobile) Home Installation	7
Installation	7-15
Care and Operation	16-21
Routine Maintenance.....	22-25
Specifications.....	26
Definitions	27
Wiring Diagram	28
Troubleshooting	29-30
Replacement Parts List / Diagrams	31-34
Optional Accessories	35
Installation Tips.....	36
Simple Operating Instructions.....	37
Safety / Listing Label.....	38
Ownership Records	39

LISTING / TESTING

Listing: The listing laboratory is ITS (Intertek Testing Services) and the listing mark is Warnock Hersey.

Testing: In accordance with the specifications and procedures listed in UL 1482 & ASTM E1509 for solid fuel room heater, this appliance has been independently tested to UL, ULC and CSA standards. UL 1482 states requirements for installations as a freestanding room heater. The safety listing label is located on an inside hopper surface of the pellet stove. Please read this safety label carefully. It contains important information about installation and operation of this appliance. This appliance is tested and listed for residential installation according to current national and local building codes as:

- A Freestanding Room Heater
- A Manufactured (Mobile) Home Heater

EPA (Environmental Protection Agency)

Status: EPA Exempt - Pellet appliances that are designed with the combustion air supply exceeding the 35 to 1 (by weight) ratio are exempt from EPA regulations and are “non-affected facilities.”

PRODUCT IS SUBJECT TO CHANGE WITHOUT NOTICE.

CONGRATULATIONS ON THE PURCHASE OF YOUR NEW PELLET STOVE MANUFACTURED BY LENNOX HEARTH PRODUCTS.

When you purchased your new pellet stove, you joined the ranks of thousands of concerned individuals whose answer to their home heating needs reflects their concern for aesthetics, efficiency and our environment. We extend our continued support to help you achieve the maximum benefit and enjoyment available from your new pellet stove.

It is our goal at Lennox Hearth Products to provide you, our valued customer, with an appliance that will ensure you years of trouble free warmth and pleasure.

Thank you for selecting a Lennox Hearth Products stove as the answer to your home heating needs.

Sincerely,
All of us at Lennox Hearth Products

PACKAGING LIST

The assembled pellet stove models T300P SERIES, are packaged with an accessory package which contains the following:

- One - Installation and Operation Instructions Manual
- One - Warranty
- One - Power cord
- One - Grate scraper
- One - Wall thermostat
- One - 20' roll of 18 gage thermostat wire
- One - Trivet, black decorative (for stove top)
- One - Damper rod
- Four - Levelers, leg, 1/4-20x 1"

USING THIS MANUAL

Please read and carefully follow all of the instructions found in this manual. Please pay special attention to the safety instructions provided in this manual. The homeowner's *Care and Operation Instructions* included here will assure you have many years of dependable and enjoyable service from your appliance.

PLANNING YOUR INSTALLATION

QUESTIONS TO ASK LOCAL BUILDING OFFICIAL

A correct installation is critical and imperative for reducing fire hazards and perilous conditions that can arise when wood pellet burning appliances are improperly installed. The installer must follow all of the manufacturers' instructions.

The installation of this appliance must conform to local codes and applicable state and federal requirements. Familiarity with these requirements before installation is essential. Important considerations to discuss with local building officials include:

1. Applicable codes (i.e. Uniform Mechanical Code, State or Regional Codes)?

Electrical codes:

In USA, NEC, ANSI / NFPA 70-1987.

In Canada, CSA C22.1

Power Supply Requirements – The power cord must be plugged into a standard, 115 volt, 60 Hz grounded electrical outlet. The approximate power requirement is 200 watts, and will peak up to 700 watts for approximately 6 minutes when the self-igniter is operating (it will turn off 2 minutes after flame detection). The power supply cord must be routed to avoid contact with any of the hot or sharp exterior surface areas of the stove. When installed in a manufactured (mobile) home appliance must be electrically grounded to the steel chassis (see page 7, *Manufactured (Mobile) Home Requirements* for additional requirements). These requirements must be met unless otherwise specified by state or local authorities.

WARNING - Electrical Grounding Instructions: This appliance is equipped with a three-prong (grounding) plug for your protection against shock hazard and should be plugged directly into a properly grounded three-prong receptacle. Do not cut or remove the grounding prong from this plug.

2. Local amendments?
3. Is a permit required - cost?
You may wish to contact your insurance company to ask if they require this.
4. Is outside combustion air required?
5. Rooms where the installation is not allowed?

INSTALLATION / MAINTENANCE STANDARDS

National Fire Protection Association – The primary NFPA standard that refers to installation and maintenance of pellet appliances and venting is NFPA 211: Chimneys, Fireplaces, Vents, and Solid Fuel appliances, Jan. 2000.

SELECTING A LOCATION

The design of your home and where you place your stove will determine its value as a source of heat. A wood stove depends primarily on air circulation (convection) to disperse its heat, and therefore, a central location is often best. There are other practical considerations, which must be considered before a final selection of locations is made.

- ◆ Existing Chimneys
- ◆ Pellet Fuel Storage
- ◆ Aesthetic Considerations
- ◆ Roof Design (rafter locations & roof pitch)
- ◆ Room Traffic
- ◆ Proximity to Combustibles
- ◆ Electrical Wiring

The installation of this stove will require some research. Once your options are determined, consult with your local building department who will be able to give you the necessary installation requirements for your area (Is a building permit required, rooms where installation may not be allowed, etc.).

WARNING: Check all local building and safety codes before installation. The installation instructions and appropriate code requirements must be followed exactly and without compromise. Alterations to the stove are not allowed. Do not connect the stove to a chimney system serving another stove, appliance, or any air distribution duct. Failure to follow these instructions will void the manufacturers warranty.

SMOKE DETECTORS

Since there are always several potential sources of fire in any home, we recommend installing smoke detectors. If possible, install the smoke detector in a hallway adjacent to the room (to reduce the possibility of occasional false activation from the heat produced by the stove). If your local code requires a smoke detector be installed within the same room, you must follow the requirements of your local code. Check with your local building department for requirements in your area.

PLANNING YOUR INSTALLATION

FLOOR PROTECTION

This appliance requires noncombustible floor protection. If the floor protection is to be stone, tile, brick, etc., it must be mortared or grouted to form a continuous non-combustible surface. If a chimney connector extends horizontally over the floor, the protection must cover the floor under the connector and at least 2" to either side.

A noncombustible floor protector must fully cover the area beneath the appliance and extend 6" to the front, 6" to the sides, and up to 6" from the back as illustrated below.

***Note: When installed at clearances less than 6", floor protection is only required to extend to the wall.**

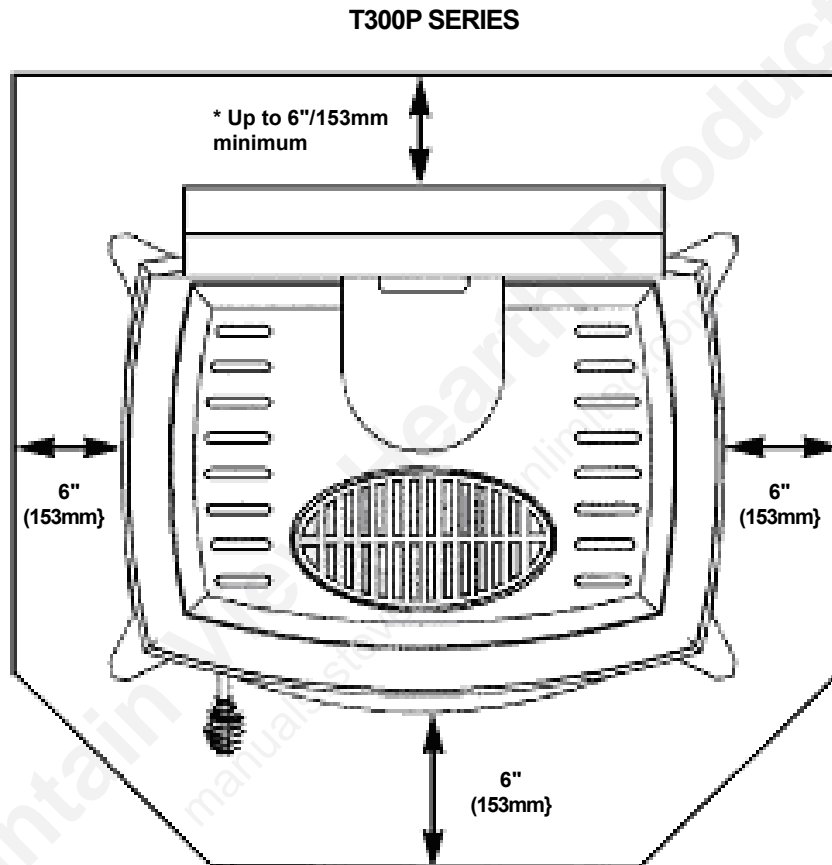

PLANNING YOUR INSTALLATION

Clearances to combustibles are determined from testing to applicable standards for allowable heat transfer. The clearances allowed as shown here, do not take into account operation or serviceability requirements.

CLEARANCES

Standard residential or manufactured (mobile) home installation. These appliances require the following minimum clearances to combustibles:

MINIMUM CLEARANCES TO COMBUSTIBLES

Model: T300P Series	Manufactured (Mobile) Home or Residential Installation	
	Horizontal Flue – Directly Through Wall	Interior Vertical Flue
	inch / millimeter	inch / millimeter
A - Sidewall to unit	◆6" / 153 mm	◆6" / 153 mm
B - Backwall to unit	2" / 51 mm	9" / 229 mm
C - Sidewall to unit Corner	2" / 51 mm	2" / 51 mm
D - Max. Depth of Alcove	●18" / 458 mm	●18" / 458 mm
E - Flue to Wall	3" / 77 mm	3" / 77 mm
◆ Measured to outside projection of cast stove top ● Minimum Alcove Measurements: Height 48" / 1220 mm Width 41" / 1042 mm		

Minimum clearances specified may not allow for ease of operation and maintenance (please take this into account when planning the installation). If installed to the minimum clearances, removal of the appliance may be necessary for servicing.

Rear Wall or Alcove

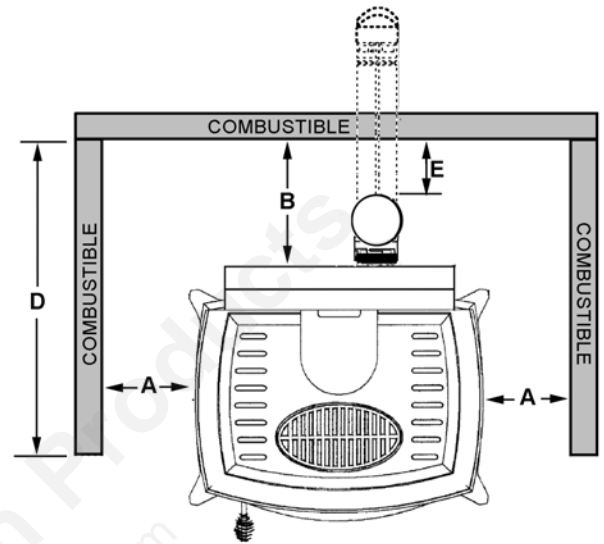

Corner

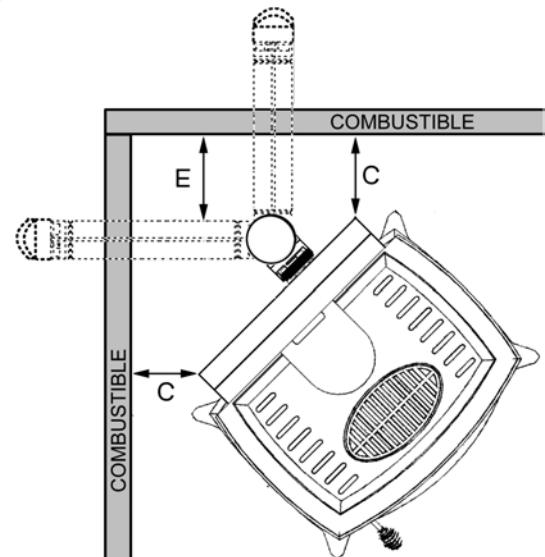

INSTALLATION

MANUFACTURED (MOBILE) HOME INSTALLATION

Model –T300P Series

In addition to the standard installation instructions, the following instructions may be required by local, state or federal building codes:

- Stove must be permanently bolted to the floor.
- An outside air inlet must be provided for combustion and be unrestricted while unit is in use.
- Stove must be permanently electrically grounded to the steel chassis of the home. The location selected for ground attachment to the stove must be dedicated for this purpose.
- See pages 10 through 15 for additional information on venting requirements.
- Do not install appliance in a sleeping room.
- The structural integrity of the manufactured home floor, walls, ceiling and roof must be maintained.

NOTE: The grounding of this product, at installation, must comply with NFPA-70 standards, CSA C22.1 in Canada, as well as any local codes.

Model - T300P SERIES

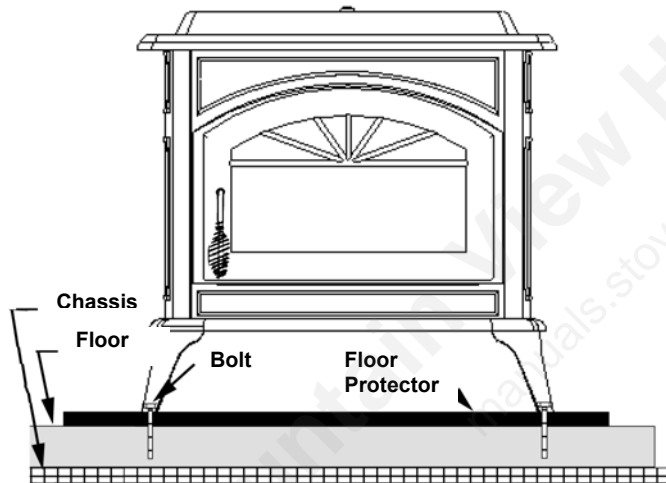

MANUFACTURED (MOBILE) HOME EXHAUST VENT PIPE INSTALLATION GUIDELINES

Use only listed type "PL" pellet vent pipe. Pipe should extend at least 3 feet above the part of the roof through which it passes. The top of the pipe should be at least 2 feet above the highest required elevation of any part of the manufactured (mobile) home within 10 feet of the pipe.

If the exhaust vent exits the manufactured (mobile) home at a location other than the roof, and exits at a point 7 feet or less above the ground level on which the manufactured (mobile) home is positioned, a guard or method of enclosing the pipe shall be provided at the point of exit for a height of up to 7 feet. The openings, if any, in this guard shall not allow a 3/4" rod to pass through. A 1/2" rod could pass through but should not be able to touch the pipe when inserted through the opening a distance of 4 inches.

REMOVING APPLIANCE FROM PALLET

1. After removing the packaging from the stove, lift the hopper lid, and remove all pre-packaged items that were shipped in the hopper. Next, open the stove door and remove all pre-packaged items.
2. Remove screws which secure legs to pallet.

INSTALLING LEG LEVELING BOLTS

The four leg leveling bolts (included in accessory package), are provided for leveling the stove if necessary. To install, thread the bolts into the existing holes in the bottom of each leg. Turn the leveling bolts to adjust for correct height.

INSTALLATION CHECK LIST

It is strongly recommended that you have an authorized Lennox Hearth Products dealer install your stove. If you install your stove yourself, you should review your installation plan with your authorized Lennox Hearth Products dealer.

Check list:

Check off each item as you proceed with the installation process.

- Read the ENTIRE stove installation section first.
- Determine the appropriate measurements and locations for your installation.
- Follow the general installation directions under Stove Installation and the installation section appropriate to your stove.
- Be sure to pre-fit all items before you install, fasten, or set up the stove permanently.

Prior to lighting your stove:

- Review the safety precaution section.
- Review the pellet fuels section.
- Review and follow the Operating Instructions.
- Plug power cord connector into corresponding connector on the back of appliance (see illustration on page 9 showing connector locations).

After you have begun operation of your stove:

- Review the routine cleaning / maintenance information.
- Enjoy the warmth from your new Lennox Hearth Products pellet stove!

INSTALLATION

DAMPER ROD INSTALLATION

1. Locate rectangular cutout on bottom stove panel behind ash pan.

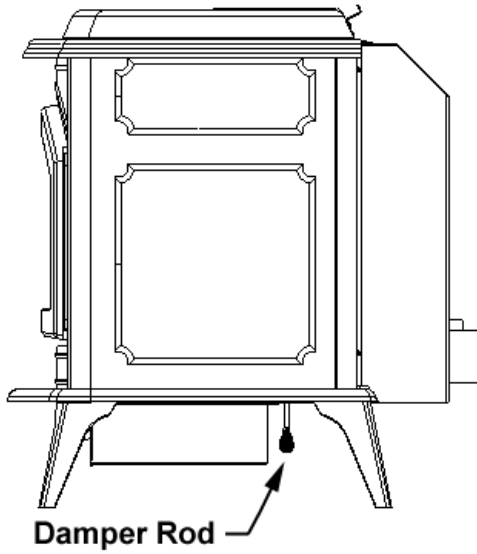

2. Screw damper rod into threaded hole.

STOVE FRONT

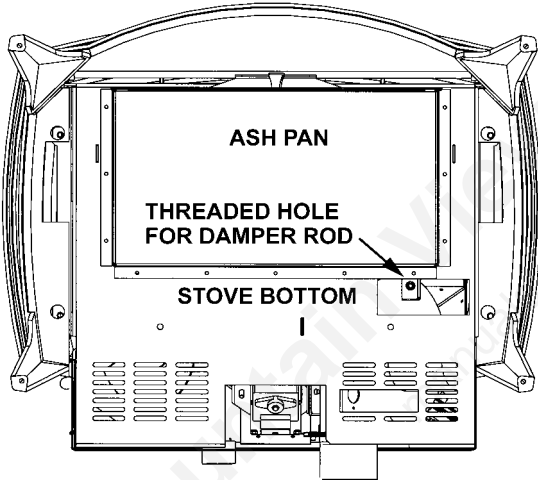

DAMPER ADJUSTMENT

The damper rod is located under the bottom plate, on the right hand side of the stove, just behind the ash pan. It is very important to preset your damper prior to burning your pellet stove.

The damper plate contains nine notches spaced in 1/4" increments that aid in positioning (see Fig. A).

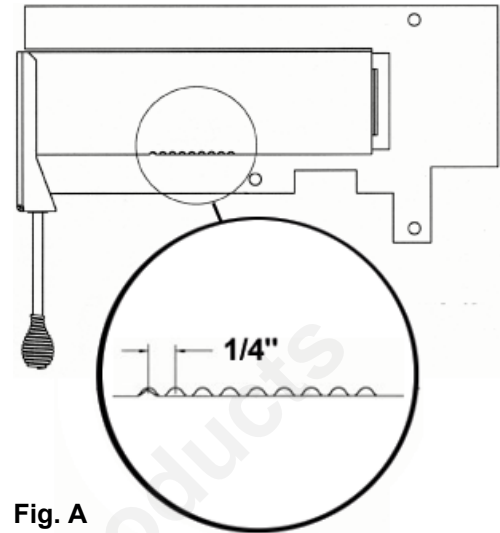

Fig. A

For initial setup, push the damper all the way in (when facing the front of the stove, "in" is to the left, and "out" is to the right) and slowly pull back three notches (see Fig. B).

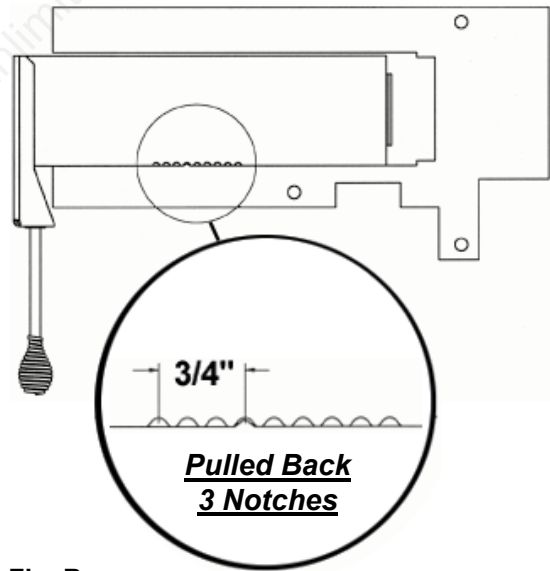

Fig. B

This setting should provide an adequate air to fuel ratio for most installations.

INSTALLATION

THERMOSTAT INSTALLATION:

NOTE: Always Disconnect Power Before Performing The Thermostat Installation.

A 24-volt wall thermostat and 20 feet of 18-gage thermostat wire is included in your stoves accessory package. It is recommended that the thermostat and thermostat wire be installed by an authorized Lennox Hearth Products dealer.

Installation Steps:

1. Unplug stove power cord from the wall outlet.
2. Locate the thermostat terminal block (see illustration).
3. Loosen the two terminal screws on the terminal block and remove the jumper.
4. Connect the two wires from your thermostat to the terminals (one per terminal). Ensure that the purple wires from the harness remain connected to the terminal block and tighten the terminal screws. Make sure the wires are firmly connected to the thermostat.
5. Plug in the stove and you are ready to operate with your thermostat!

IMPORTANT: IF THE WALL THERMOSTAT PROVIDED IS NOT USED, THE JUMPER IS REQUIRED FOR THE STOVE TO OPERATE.

Model T300P Series
(viewed from stove back)

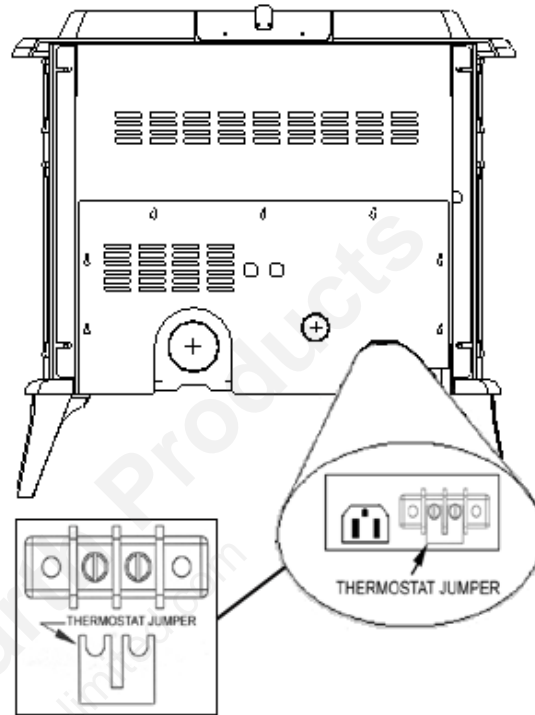

Terminal Block for Thermostat

Leave Jumper on, If Thermostat Is Not Used

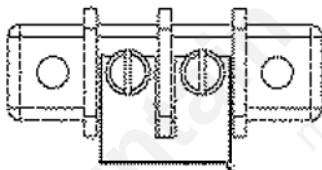

Remove Jumper if Thermostat Is To Be Used

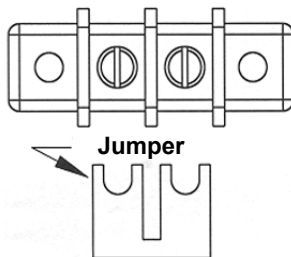

INSTALLATION

VENTING REQUIREMENTS

It is recommended that only an authorized dealer install your pellet stove. The specified installation requirements must be followed to ensure conformity with both the safety listing of the appliance and local building codes. All clearances, installation instructions and precautions specified by the vent manufacturer must be followed.

Selecting a Location - Review the appliance clearance requirements before installing the venting system (see *Clearances*, page 6). Position the appliance far enough away from walls to allow adequate room for servicing. Choose the appliance location with the least amount of interference with the house framing, plumbing, wiring, etc.

Preferred Vent Configuration – For the best performance, we recommend a vent run design which runs vertically and terminates above the roofline. This design will allow natural draft to improve the flow of flue gases and will aid in combustion and stove performance.

Type of Pipe – This stove requires type “PL” (pellet vent pipe, sometimes referred to as “L-Vent pellet vent”), which conforms to UL standard 641. Connect the pellet vent pipe or the “tee” to the flue collar using a minimum of three screws and seal as specified in “Pipe Joint Requirements” on this page. Do not use class B gas chimney or single wall chimney as a substitute.

Size of Pipe -These pellet appliances are approved for use with the following vent sizes: 3” (75mm) standard, or 4” (100mm). See page 12 for determining correct size vent to use. Use a 3” (75mm) to 4” (100mm) adapter (Cat. No. 14M81) or a 3” (75mm) to 4” (100mm) “tee” in order to run 4” (100mm) pipe.

Offsets - In every installation, a single or double clean-out “tee” is recommended for every ninety-degree offset (this tee will help collect ash residue and will allow for routine cleaning without the need to disconnect sections of pipe).

Note: Offsets and horizontal runs accumulate fly ash and soot which reduces the exhaust flow and performance of the stove.

Total Offsets in venting system should not exceed 270° total in direction change.

Horizontal Runs - The maximum total horizontal run must not exceed 10 feet (3.1 meters).

Horizontal run of pipe requires 1/4” / 7 mm rise per foot.

Pipe Clearances / Requirements – See pipe manufacturers instructions for installation of venting components and clearances. Follow pipe manufacturers installation precautions for passing pipe through a combustible wall or ceiling (i.e. use an approved thimble).

Notes:

All pellet vent pipe requires 3” (75mm) clearance from outside of pipe unless otherwise specified by vent manufacturer.

A support bracket should be installed every 4’ (1.2m) of pellet vent pipe on the exterior wall of the house unless otherwise specified by vent manufacturer.

Pipe / Liner Joint Requirements - All pipe joints must be secured with a minimum of 3 screws. ALL horizontal joints must be sealed gas tight. Use RTV silicone with a rating of at least 570° F (969° C), or Interam to provide a complete seal at the flue collar and on all joints.

Connection to Masonry Chimney through a Wall - Be sure to verify the construction of a masonry chimney, as it may have combustible framing.

The use of single wall flex or rigid 24 gage stainless steel pipe as a liner is approved.

Connection to an Existing Class A Chimney - A chimney adapter can be used to make the connection from 3” / 75mm or 4” / 100mm pellet vent pipe to existing UL chimney system. Verify with the pipe manufacturer that your pipe brands will interconnect. The use of single wall flex or rigid pipe (24 gage stainless steel) as a liner is approved.

Direct-Vent Installations (Horizontal): On all direct-vent installations (short, horizontal runs with no vertical pipe); care should be taken when choosing a location for terminating the vent. It is not recommended to directly vent the exhaust on the prevailing wind side of the house. It is recommended that when an appliance is vented directly through a wall, a minimum of 8’ (2.5M) of vertical pipe should be installed to create some natural draft. This will reduce the possibility of smoke or odor entering the dwelling during appliance shutdown or loss of power.

INSTALLATION

VENT TERMINATION

Do not terminate vent in an enclosed or semi-enclosed area such as: carports, garage, attic, crawl space, under a deck, porch, narrow walkway, closely fenced area, or any location that can build up a concentration of fumes such as a stairwell, covered breezeway, etc.

Vent surfaces can get hot enough to cause burns if touched. Adults should supervise children when they are in the area of a hot stove. Non-combustible shielding or guards may be required.

Termination Cap: The termination of the outside chimney of the pellet stove shall be located in accordance with the following:

- A. Higher than 3' (.92M) above any forced air inlet (air conditioner, etc.) located within 10' (3M).
- B. Not less than 4' (1.2M) below, 4' (1.2M) horizontally from or 1' (3.1M) above any gravity air inlet (door, window, etc.) which flue gases could re-enter the dwelling.
- C. Not less than 2' (.6M) from combustible materials such as an adjacent buildings, fences, protruding parts of the structure, roof overhang, plants and shrubs, etc. and not less than 7' (2.1M) above grade when located adjacent to the public sidewalks (access). The final termination of the exhaust system must be configured so that flue gases do not jeopardize the safety of people passing by, overheat combustible portions of nearby structures or enter the dwelling.
- D. Not less than 3' (.92M) below an eave (maximum overhang of 3' (.92M) or any construction that projects more than 2" (51mm) from the plane of the wall.
- E. The distance from the bottom of termination to grade is 12" (305mm) minimum. This is conditional upon plants and nature of grade surface: Be careful to choose a location for the vent termination which does not expose people or shrubs to high heat from the exhaust gases. The exhaust gases are not hot enough to ignite grass, plants and shrubs located in the vicinity of the termination although they should be a minimum of 3' (.92M) away. The grade surface under the termination must not be a lawn.
- F. Since sparks may escape from the exhaust pipe of any stove, use caution when positioning the vent pipe. Refer to pipe manufacturer's instructions when installing and terminating the exhaust. The vent pipe should be horizontal **and never run the pipe in a downward direction** (recommend a 1/4" (7mm) rise per foot horizontal).

Note: It is not recommended to terminate exhaust vent on the prevailing wind side of the house.

Chimney Height Requirements

The vent termination height required is 12" minimum above the roof penetration point as illustrated below (Ref. National Standard, NFPA 7-4.1). Check with your local building official for additional requirements for your area.

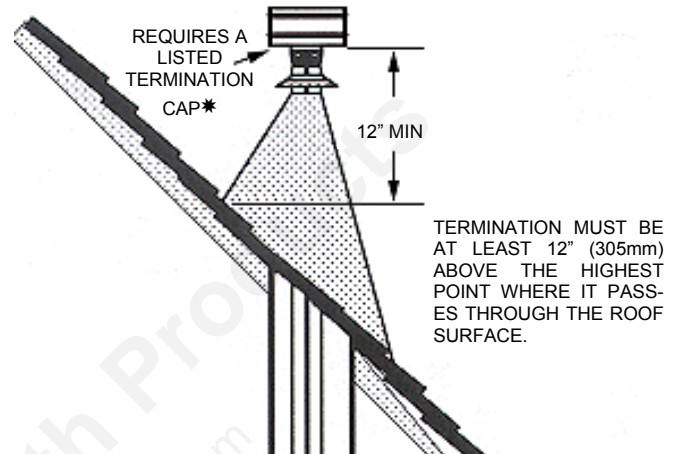

Manufactured (Mobile) Home Chimney Height Requirements

The chimney must extend 3' (.92M) above the level of roof penetration and a minimum of 2' (.61M) higher than any roof surface within 10' (3M) (see below). Check with your local building officials for additional requirements for your area.

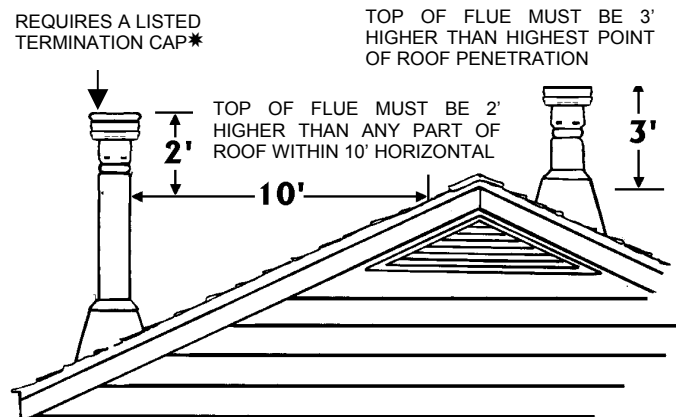

To pass inspection in nearly any jurisdiction, the chimney must meet both safety and exhaust flow requirements. The (3' by 2' by 10' rule applies to both masonry and factory built chimneys.

* Ref. NFPA 7 – 4.1.2, Vents installed with a listed cap shall terminate in accordance with the terms of the cap's listings.

INSTALLATION

DETERMINING SIZE OF PIPE TO INSTALL

To determine what diameter pipe to use in an installation (3" or 4"), first find the "equivalent pipe length" using the following guidelines, then plot this figure and the altitude on the chart.

Fill out the installation chart, and calculate your total equivalent pipe length. After you have the total equivalent pipe length, use the *Pipe Selection Chart* below to determine if your installation requires 3" or 4" exhaust pipe.

INSTALLATION CHART

Type of Pipe	# of Elbows or Feet of pipe		Equivalent Feet	Total Equivalent Feet
90° Elbows		x	5 Ft. (1.5M)	
45° Elbows		x	3 Ft. (1M)	
Horizontal Pipe		x	1 Ft. (.3M)	
Vertical Pipe		x	.5 Ft. (.15M)	

SAMPLE INSTALLATION CHART

Type of Pipe	# of Elbows or Feet of pipe		Equivalent Feet	Total Equivalent Feet
90° Elbows / Tee (A & G)	2	x	5 Ft. (1.5M)	10 (3M)
45° Elbows (C)	1	x	3 Ft. (1M)	3 (1M)
Horizontal pipe (B & F)	3	x	1 Ft. (.3M)	3 (1M)
Vertical pipe (E)	8	x	.5 Ft. (.15M)	4 (1.2M)
				Total = 20

- A- 90 Degree Elbow
- B- 1' Horizontal Pipe
- C- 45 Degree Elbow
- D- Standoff Braces
- H- Wall Thimble
- E- 8' Vertical Pipe
- F- 2' Horizontal Pipe
- G- 90 Degree Tee

NOTE: All equivalent pipe styles shown to the right are standard for all freestanding models.

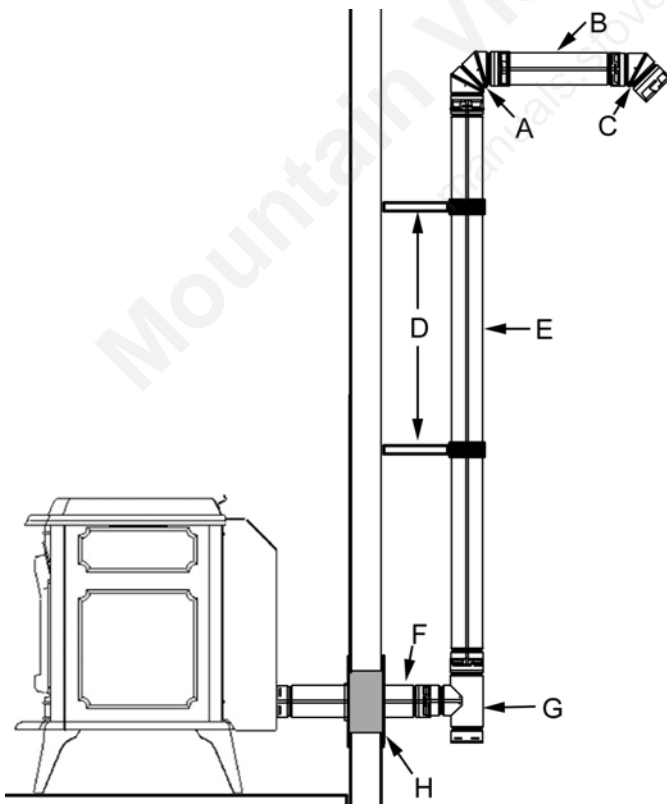

PIPE SELECTION CHART

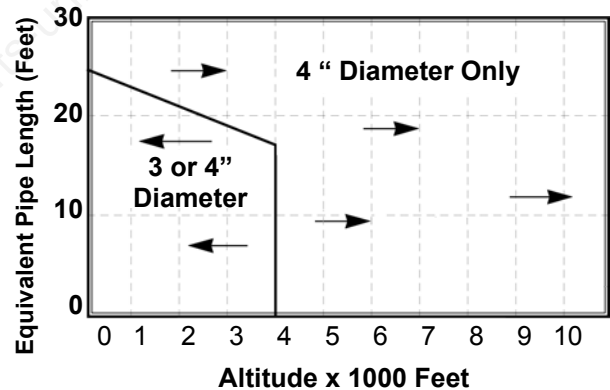

INSTALLATION

INSTALLING YOUR PELLET STOVE

Standard Horizontal Exhaust Installation (Direct Vent)

1. Locate the proper position for the listed type "PL" wall thimble. Avoid cutting wall studs when installing your pipe. Use a saber saw or keyhole saw to cut the proper diameter hole through the wall to accommodate the wall thimble. Use extreme caution to avoid cutting into power lines within the wall of the home. The hole size will depend on the brand of pellet vent that you are using. Install the wall thimble in the hole.

ALL INTERLOCKING PIPE CONNECTIONS WITHIN THE ROOM MUST BE SEALED WITH RTV AND SECURED WITH A MINIMUM OF 3 FASTENERS PER CONNECTION.

2. Position the stove approximately 12" (.3M) from the wall on the floor pad. Push listed type "PL" pipe through wall thimble. Squeeze a bead of high temperature silicone (RTV) sealer around the end of the machined portion of the 3" (75mm) pipe connector on the back of the stove. Firmly push on a section of listed type "PL" pipe until inner pipe liner pushes into the bead of RTV sealer

3. Push the stove (with pipe attached) towards wall. Pipe will go through the wall thimble. Do not position the back of the stove closer than 1" (25mm) from the wall.

NOTE: Greater back clearance will improve the serviceability of the stove.

4. Install listed type "PL" 45-degree elbow with rodent screen or cap (optional) on outside end of pipe. The rodent screen should be no less than 1/2" (13mm) mesh and may clog with soot and ash if left unattended during the burn season.

NOTE: The end of the exhaust pipe must extend a minimum of 12" (.3M) from the outside of the building.

5. If the installation includes a source of outside combustion air; cut a separate hole through the wall for the fresh air tube. This tube should be 1-5/8" (42mm) [min.] diameter, steel only. Connect outside air pipe to air inlet on stove. This tube must be terminated with a 90 degree elbow or hood.

NOTE: Combustion air may also be drawn from a vented crawl space under the home. All joints for connector pipe are required to be fastened with at least three screws. If vented horizontally, joints shall be made gas-tight in a manner as specified above. Install vent at clearances specified by the vent manufacturer.

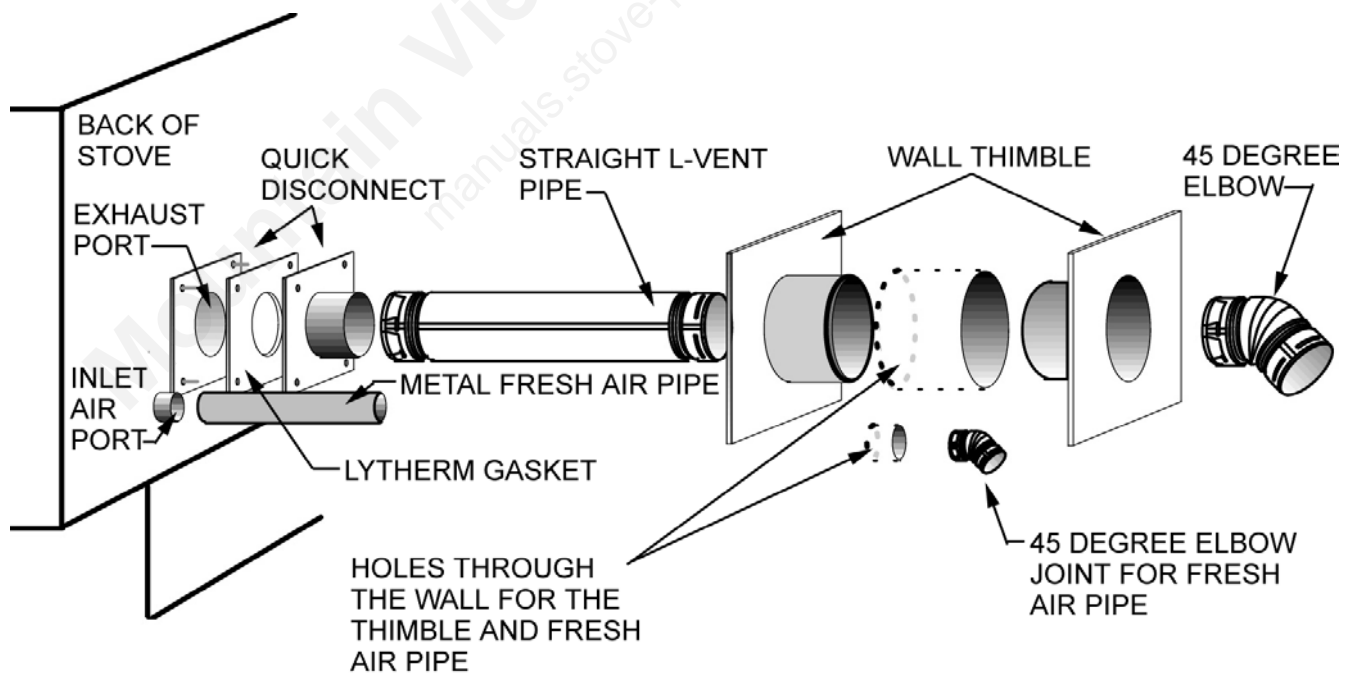

INSTALLATION

INSTALLATION CONFIGURATIONS – Standard Horizontal Installations

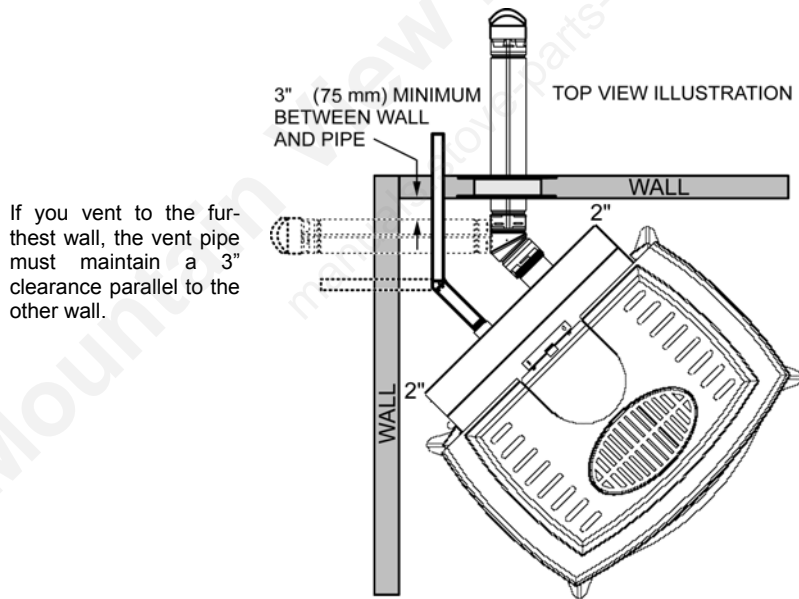
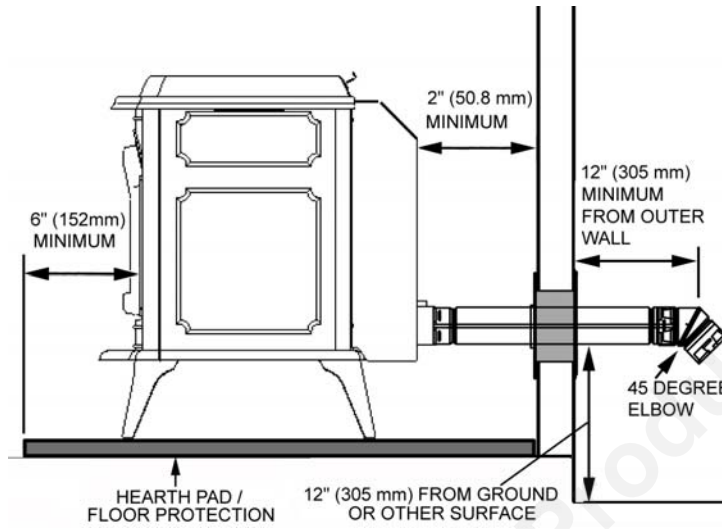

Note: Horizontal run of pipe requires 1/4" / 7 mm rise per foot.

INSTALLATION

Installation Configurations / Standard Venting Options

This appliance may be connected to an existing flue or by installing listed type "PL" vent pipe. If a liner is run all the way to the top of the existing chimney, the existing flue should be sealed with a steel plate. Start a vertical run with a Tee at the back of the stove. Other options are illustrated below. *Note:* See page 11 for Vent Termination Requirements.

Preferred Installation – Vertical Vent Through the Roof.
This venting configuration allows for the best stove performance. The vertical pipe promotes natural draft and with the chimney inside the dwelling, the flue gases stay warm, thus rising at a consistent rate.

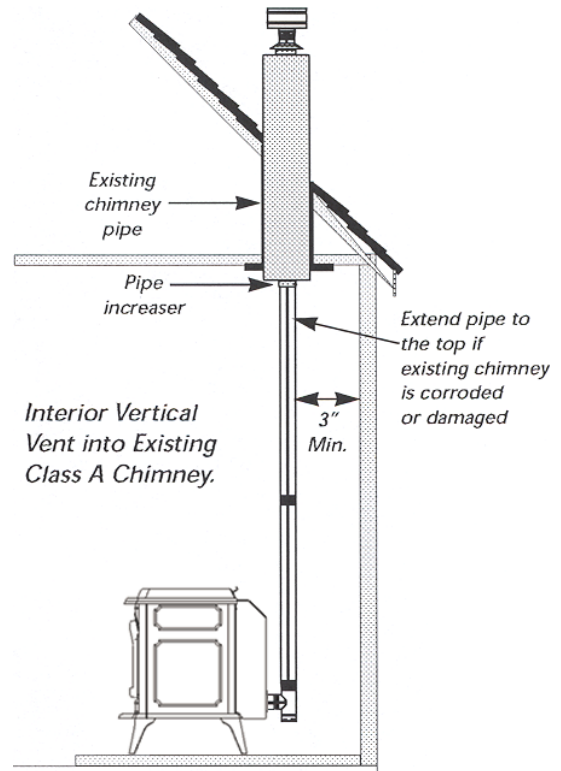
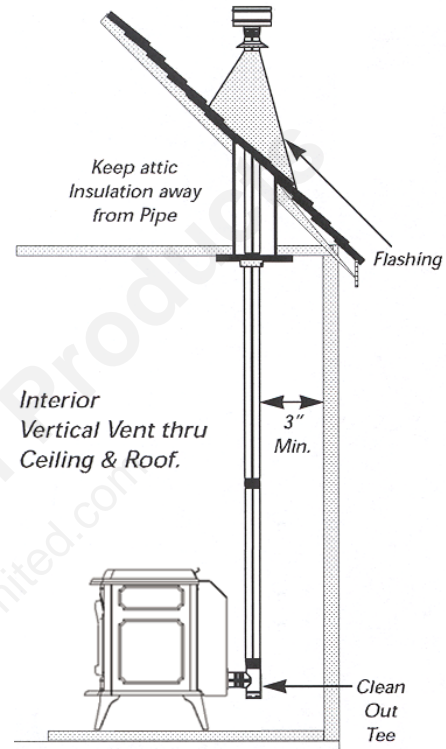
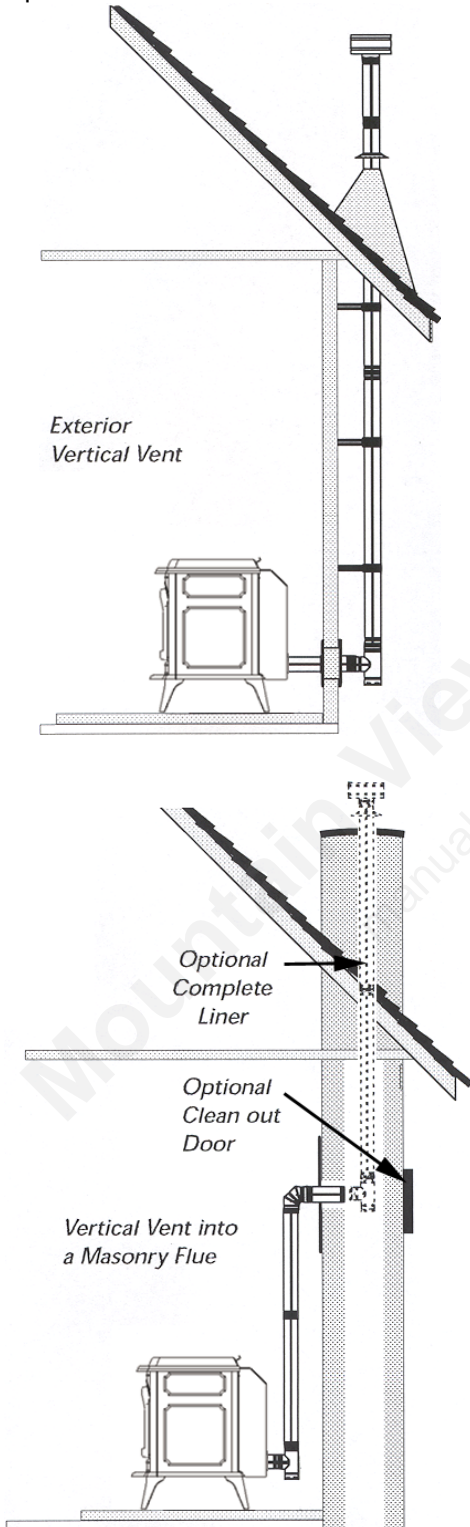

CARE AND OPERATION

CONTROL BOARD OPERATION

Stove On / Off Button – This button will turn your stove on or off while in Manual or Automatic mode (see page 19 for details). The green on / off light at the top of control board will indicate the on / off status.

Heat Output Button – The heat output button has three selection settings, Low, Medium and High. Pressing the button will scroll the red indicator lights from Low to High. The button controls the pellet feed and combustion airflow simultaneously. The control board is preset to provide the optimum ratio of fuel and air at each setting. Settings can be changed at any time but will only take affect after the start-up cycle is complete. Each press of the Heat Button will increase the heat output, and will scroll to the lowest setting after reaching the maximum setting.

Blower – The blower button operates the room air blower. This will change the flow of hot air into the room. Three choices are available Low, Medium, and High. When the Blower Button is pressed the yellow indicator light will scroll to Low, Medium, or High. **NOTE:** When running your stove on high heat output, the control board will not allow you to select the low blower speed. This is a safety precaution to protect against overheating. Blower settings can be changed at any time, but will only take affect after the start-up cycle is complete.

Fault Mode – The control system automatically monitors the flame using a photoeye. If the stove runs out of pellets the control board automatically goes into a “fault” status. The control board will initiate the shut down cycle and safely shut down the stove leaving it in the “fault” mode. The on / off indicator light near the top of the control board will flash rapidly when in this mode. After refilling the hopper with pellets, press the Start Button. If a thermostat is not being used the stove will go into the start-up cycle. If a thermostat is being used the stove will go into the start-up cycle if the thermostat is in the demand mode. If the thermo-

stat is in the stand-by mode when the fault is cleared, the stove will remain in the stand-by mode until it closes again.

NOTE – If the fuel feed trim or combustion air trim needs to be adjusted, contact an authorized Lennox Hearth Products Technician to calibrate internal software. It is recommended that the damper be used to fine-tune your stove to your particular fuel and installation configuration (see *Damper Adjustment* on page 8 and *Damper Adjustment Guideline* on page 20).

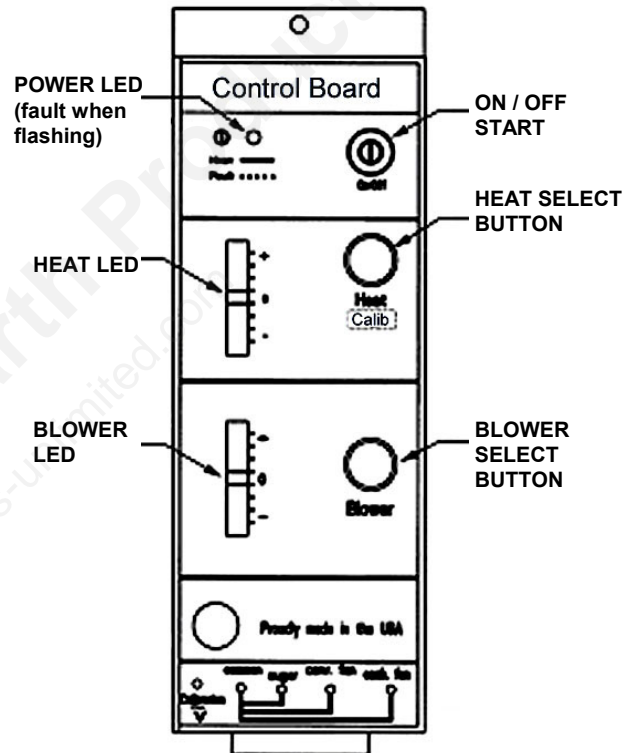

CARE AND OPERATION

Note: The control board is equipped with an internal memory which will recall the last setting and mode the stove was in prior to loss of power. Because we individually check each stove prior to packaging, one of the two scenarios will appear when you first plug in your stove.

- 1). The Green LED at the top of the control board will illuminate and the blowers will be running. This is a standard cool down mode and will last no longer than five minutes. This happens during testing when the stove is turned off (which initiates cool down mode) and then is unplugged.
- 2). The Green LED at the top will illuminate and the red and yellow LED's will illuminate on the control board, indicating that the stove is in the run mode. This happens during testing if the stove is unplugged without first turning the control board off (the control board remembers its last setting, which was the run mode).

If your stove follows that described in number 2 above, simply press the ON / OFF button once to turn the stove off, this will initiate the cool down mode. The stove can be restarted at any time during the cool down mode by pressing the ON / OFF button once.

Start-up Sequence of Events

1. Fault time delay is initiated (14 minutes 15 seconds).
2. Fuel feed rate of 100% for 1 minute 50 seconds (when trim left at factory setting of 0) auger trim setting ranges from 1:26 to 2:14 depending on -4 to +4 respectively.
3. Exhaust blower operation starts (medium range voltage).
4. Room air blower operation starts (medium range voltage). Power LED is activated (steady green).
6. Igniter operation activated (line voltage).
7. Photoeye looks for flame (flame dominance scheme).
8. * If needed second & third fuel dumps are available at predetermined time deliveries (4 minutes & 6 minutes after initial).

Flame Detection Sequence of Events - This is what happens after flame has been detected.

- Happens within the *Start-up Time Delay* sequence.
- 0 to 1 minute no fuel feed.
- Flame settles.
- Bed of embers built.
- 1 minute mark: Fuel Feed rate 20% for 4 minutes 15 seconds (1 second on / 4 seconds off).
- 2 minute mark: igniter turns OFF / room air blower = panel setting.
- 5 minute 15 seconds mark: exhaust blower = panel setting / LED indicator still active.

Start-up Time delay ends 14 minutes 15 seconds after pushing the start button!

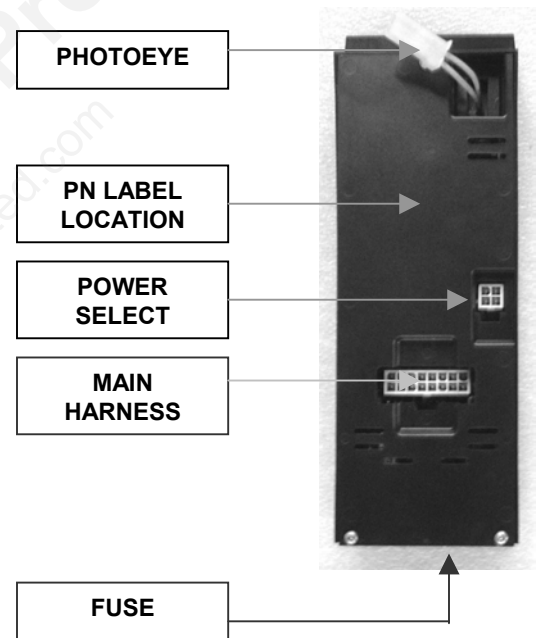

CARE AND OPERATION

Combustion Voltage Trim Steps:

1. Push button "twice" for access voltage calibration mode.
2. Identify the current calibration setting indicated by one YELLOW LED bar.
3. Push the "HEAT" control button to adjust setting UP. Each push raises the YELLOW LED bar & increases voltage 5%.
4. Push the "BLOWER" control button to adjust setting DOWN. Each push lowers YELLOW LED bar decreasing voltage 5%.
5. Push the calibration button once to lock in selected results.

Fuel Delivery Rate

The feed rate switch manages the fuel delivery rate by controlling the amount of time the auger motor will run as follows:

Feed Rate Setting	Auger Motor ON / OFF Time (seconds)	* Lb.'s per hour fuel delivery	◆ Approximate BTU per hour fuel delivery	Burn Time (hours)
Low =	1 on / 5.00 off	1.5 Lb.'s / hr.	13,000 BTU / hr	34
Med.=	1 on / 3.30 off	2.5 Lb.'s / hr.	21,000 BTU / hr	20
High =	1 on / 1.60 off	3.8 Lb.'s / hr.	32,000 BTU / hr	14

- * Feed rates are approximations only. Actual feed rate will vary depending on size, quality and length of fuel used and variations in line voltage.
- ◆ Estimated heat input based on fuel value of 8400 BTU per lb. of fuel.

Your pellet stove can be operated in either manual or automatic mode. The manual mode is used when operating without a thermostat. The automatic mode is used when utilizing a wall thermostat. When utilizing the thermostat capability the burn time can be extended dramatically depending on thermostat setting. Note: It is normal for some ash to build up on the inner glass surface at the lower burn settings.

Initial Start-Up / Empty Hopper or Feed Tube:

During an initial start-up, or in the case where the hopper has run out of fuel, it will be necessary to prime the auger feed system. The control board is set to deliver fuel for approximately 2 1/2 minutes during start-up, which, with a fully primed auger tube, will provide the appropriate amount of fuel for ignition.

When first starting your pellet stove, it will be necessary to prime the auger tube. To prime the auger tube you need to first fill the hopper with pellets, and press the ON button on the control board. Wait approximately 2 1/2 minutes and turn the control OFF and then back ON again. Wait an additional 2 1/2 minutes (if necessary) and continue this process until fuel begins to fall into the UltraGrate™. Remember, different brand fuels feed at different rates.

Once fuel starts to enter the UltraGrate™, turn the stove OFF and then back ON. The auger tube should now be primed and the stove should deliver enough fuel for proper ignition. It may be necessary to follow these procedures in the event that the hopper runs completely out of fuel.

CARE AND OPERATION

Manual Operation:

Pressing the stove ON / OFF switch initiates the start-up cycle. The green ON / OFF light, near the top of the control board, will light up to indicate the “on” status. The fan speeds and pellet feeds are fixed during this time to provide appropriate ignition. The Fast-Fire igniter system will light the pellets feeding to the UltraGrate™, after about 3 minutes. The start-up cycle is in effect for approximately 2 minutes after flame is detected in the UltraGrate™. A photoeye monitors the existence of flame. After the start-up cycle your stove will be in the run mode. At this point the stove will operate in the heat output and blower settings selected. These settings can be selected either during or after the start-up cycle. Pressing the stove ON / OFF switch during the run mode will initiate the shut down cycle. The ON / OFF indicator light will turn off. The pellets will stop feeding and the blowers will run at a fixed speed for approximately 10 minutes. At this point your stove is safely shut down and can ONLY be re-started by pressing the stove ON / OFF switch again.

Automatic Operation:

Your stove is capable of running in an automatic mode with the use of a wall thermostat. NOTE: For the thermostat to control the operation of the stove, the “on” status must be active on the stove’s on / off switch. The thermostat will establish either a demand mode or a stand-by mode. The thermostat should be set for the desired room temperature. If the room temperature drops below the level on the thermostat the stove will automatically begin the start-up cycle, as explained above in the Manual Operation section. Once the start-up cycle is completed the stove will operate in whatever heat and blower setting you have selected. For best operation under thermostat control, the Medium or High settings recommended. When the desired room temperature is reached, the stove will automatically go into the shut down cycle. The pellet feed will stop and the blowers will continue for a controlled time allowing safe shut down of your stove. All lights will remain on when the thermostat is open. The heat and blower settings can be changed at any time, but only take affect during the run mode. When the temperature in the room drops to the level set at the thermostat, the stove will again begin the start-up cycle and resume automatic operation in the demand mode.

NOTE: If the stove on / off switch is pressed while the thermostat is in the standby mode the stove will not restart until the thermostat closes.

Lighting Procedure Without Igniter

Your pellet stove can be lit manually without using the automatic igniter by following the procedure below. If your stove is set up to run on a thermostat, the thermostat circuit needs to be closed (as if permanently in the demand mode). The thermostat wires should be removed from the rear of the stove and replaced with the jumper originally supplied with your stove. If a jumper is not available the thermostat should be set to the highest setting. This will keep the stove in the demand mode. If your automatic ignition system should ever need troubleshooting, repair or replacement, please contact your authorized Lennox Hearth Products dealer.

1. Press the ON switch on the control board.
2. Wait approximately 2 1/2 minutes while the pellets prime the grate (the pellets will stop feeding automatically).
3. Place a small amount of an approved (non-volatile) fire starter on top of the pellets in the grate, (see your authorized Lennox Hearth Products dealer for appropriate fire starting products). DO NOT USE FLAMMABLE LIQUIDS TO START YOUR STOVE!
4. Light the “fire starter” with a match and close the door.
5. The photoeye will detect that a flame is present and will begin feeding pellets in approximately 2 minutes.
6. The control board will continue to go through the normal start-up cycle and the flame should be well established within 10 minutes from the time the ON button was initially pressed. Remember – you are now in manual mode and heat settings should be selected to the desired room heat level.

Turning Off Your Stove

Press the stove on / off switch to initiate the shut down cycle. The pellets will stop feeding and the blowers will continue to run on a timed cycle. The stove will shut down safely upon completion of the shut down cycle.

CARE AND OPERATION

DAMPER OPERATION

The damper is a plate that helps control the amount of airflow supplied for combustion. With the damper pushed in all the way, the airflow is at its minimum. As the damper is pulled out, more air is allowed to flow.

It will be necessary to monitor the appearance of the flame during the first 4-8 bags of pellets. If your flame is smoky red / orange with evidence of soot at the top of the flame, you need more combustion air; pull the damper out one notch and re-evaluate the appearance of the flame. It may be necessary to continue this process, moving the damper one notch at a time until proper combustion is attained (the flame should become yellow and begin to “dance”). If the flame is “short” at the higher burn rates, or if the pellets are burning up in the grate before new pellets are fed into the fire, push the damper in one notch and monitor the flame. Continue the process of moving the damper one notch at a time and evaluating the flame until proper flame appearance is achieved.

Once the damper has been properly set, it should not need adjusting unless you are changing the grade of pellet fuel, in which case the damper may need to be adjusted.

DAMPER ADJUSTMENT GUIDELINE

Lack of Combustion Air: By opening the damper, this will increase combustion air delivery. Symptoms of insufficient combustion air include; unburned fuel, lazy smoky or red / orange flame, excessive ash or soot, excessive buildup on glass.

Contributing factors:

- High Altitude – Lack of oxygen
- Restrictive Venting (elbows, horizontal runs, cold external chimneys, etc.).
- Dirty / Poor Quality Fuel.

Note: Excessive amounts of fly ash built-up in the grate, clinkers in the grate or leakage of air (if the grate is not properly seated) will starve the fire for air. See *Routine Maintenance*, pages 22-25 for information on cleaning the stove.

Excessive Combustion Air: By closing the damper, this will reduce combustion air delivery. Symptoms of excessive air include; fuel burns too quickly (results in smoking or smoldering pellets), white to yellow flame, etc. If the damper is open too much, the burning pellets will lift off the grate and fly up into the air much like popping corn does.

Contributing factor:

- Venting system providing excessive draft.

Correct Combustion Air / Proper Burn Characteristics: When the damper is correctly set, the burning pellets should move (wiggle) around slightly and the flame should be bright yellow.

AUTOMATIC SAFETY FEATURES

Power Outage:

During a power outage, the stove will shut down safely. The stove will automatically restart when power is resumed. The solid state control board has an internal memory that will retain heat output and blower speed settings through voltage interruptions.

A small amount of smoke may leak from the top of the window glass, the hopper and from the combustion air intake, if the stove is vented horizontally with no vertical pipe. This will not persist for more than 3 to 5 minutes and will not be a safety hazard. It may set off your smoke alarm.

Note: If the area in which you live is prone to frequent power outages, it is recommended that a minimum of 8 feet (2 ½ meters) of vertical vent pipe be included in a freestanding installation to induce a natural draft in the event of a power failure.

Overheating:

A high temperature disc (thermal switch) will automatically shut down the stove if it overheats. Allow up to 45 minutes cooling time before re-lighting. Keep enough convection air going through stove to keep it cooling properly, this will ensure long life of the stove. If the overheating continues, contact your authorized Lennox Hearth Products dealer for more information.

CARE AND OPERATION

FUEL REQUIREMENTS

Using the UltraGrate™ burn system, this appliance has been designed to burn wood residue pellets with up to 3% ash content. Agricultural pellets (i.e...corn, alfalfa etc.) are not permitted to be burned in the stove. Dirty fuel will adversely affect the performance of the stove.

Caution: The use of unapproved, dirty, wet and / or high salt content fuel will void the warranty!

Wood pellets manufactured to the Pellet Fuels Institute (P.F.I.) certification standard are available in two grades, standard and premium. The primary difference between the two is the ash content of the pellets.

The P.F.I., specification for standard grade & premium grade residential pellet fuel is as follows:

- CHLORIDES (Salt): Less than 300 p.p.m..
- BULK DENSITY: 40 lb. / cu. ft. minimum
- MOISTURE CONTENT: 8% maximum
- ASH CONTENT: < 3% maximum (standard grade) < 1% maximum (premium grade)
- FINES: 0.5% maximum through a 1/8" screen

Pellet Feed / Pellet Size:

The pellet feed system is designed to handle a wide range of pellet sizes up to a maximum of 5/16" diameter. Different pellets may feed at considerably different rates. You may notice a difference in the burn if you change pellet fuel sizes. The longer the pellet, the slower it will feed and vice versa. If the stove will not stay burning at the minimum fuel feed setting, those particular pellets may not be feeding fast enough. If this happens, reduce the amount of combustion air by adjusting the damper. See page 8 before adjusting the damper.

Long Burn Time:

When operated correctly, this appliance cannot be over-fired. Continuous operation at a maximum burn can, however, shorten the life of the electrical components (blowers, motors, and electronic controls), and is not recommended. Typical approved operation would include running at the low to mid range setting with occasional running on the maximum setting during the coldest periods of the winter. The blower speed control should be turned to high when operating the stove on the high heat setting. A lower heat setting is recommended for overnight operation or when the room is vacated for long periods of time.

Note: See *Fuel Delivery Rate* on page 18 for burn times.

CLINKERING

Silica (or sand) in the fuel, along with other impurities, can cause clinkering. A clinker is a hard mass of silica formed in the burning process. Clinkering is a function of the fuel, (not the stove), but adversely affects the performance of the stove by blocking off the air passages in the grate. Even P.F.I. approved pellet fuel may tend to clinker. A clinker can be removed from the UltraGrate™ and placed in the ash pan with the use of the grate scraper / ash pan tool furnished with your stove. See Routine Maintenance, pages 22-25 for more information on cleaning.

ASH

The frequency of removal of the ash and maintenance performed on the stove is directly proportional to the ash content of the fuel and the operation duration of your pellet stove. Low ash fuel may allow longer intervals between cleaning, however, a stove burning high ash fuel may need to be cleaned as often as everyday.

PLEASE NOTE: Lennox Hearth Products has no control over the manufacturing of pellet fuel and will not be held responsible for poor stove performance or any damage caused by inferior pellet fuels.

FUEL FEED RATES

Different brands of pellets will feed at varying rates due to their size and density (length and diameter). This may require a slight adjustment in the damper control (see page 8) or the fuel feed trim to compensate (see Note on page 16).

UltraGrate™

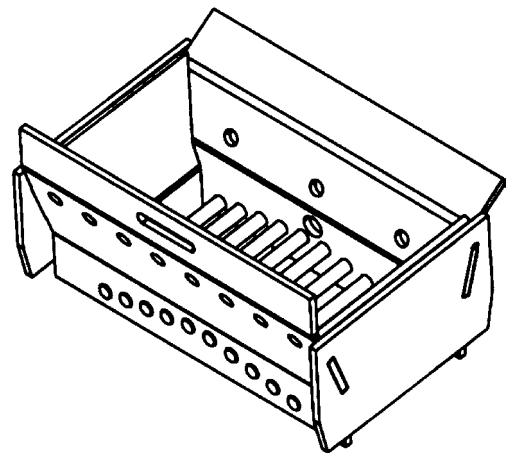

ROUTINE MAINTENANCE

* Inspect your stove or insert at minimum frequency stated until you establish a minimum frequency required for your installation (frequency will vary depending upon fuel BTU value / ash content, usage, and misc. installation variables).

ROUTINE CLEANING

Note: Stove will need to be shut off and cooled enough to handle before routine cleaning is performed.

Always disconnect power before doing any routine cleaning.

The following areas need to be inspected and cleaned during routine cleaning:

- UltraGrate™ (burn grate)
- Ash Slide Plate
- Ash Pan
- Heat Exchange Tubes
- Photoeye
- Exhaust Passages and Vent Pipe
- Gaskets
- Window Wash
- Rear Stove Compartment

UltraGrate™ (BURN GRATE)

The UltraGrate™ should be inspected periodically to assure that the air holes have not become clogged with ash or clinkers. The UltraGrate™ can easily be cleaned with the grate scraper / ash pan tool, or it can be removed for cleaning. It is very important to monitor the ash build up under the UltraGrate™, as excessive amounts of ash will block combustion air from entering the grate, causing pellets to pile-up in the grate. The ash build-up under the grate is easily dumped into the ash pan by pulling out the ash slide weekly as shown below. The grate cleaning procedure is the same for all models.

UltraGrate™



* (Recommended Frequency of 1 day – 2 weeks)

ASH PAN

The ash pan will have to be emptied periodically, depending on amount of fuel consumed. The T300P Series ash pan is pulled straight out using the black pull knob located on the front of the ash pan (see following picture).

Ash Pan



* (Recommended Frequency of 2 days – 2 weeks)

ASH SLIDE PLATE

Ash that accumulates around the grate can be “dropped” into the ash pan without opening the firebox door. Simply pull open the ash release slide plate as shown in photo using the grate scraper tool provided. Remove the ash pan as shown. Note: Make sure to fully close the plates when finished. Failure to close the ash release slide plates completely may cause the fuel to burn poorly (due to reduced airflow through the grate), which may then cause pellets to “pile up” in the grate.

Ash Slide Plate



*(Recommended Frequency of 1 day – 2 weeks.)

ROUTINE MAINTENANCE

PHOTOEYE

The photoeye is positioned to view the flame from the top of the auger feed tube. It is located below the auger cover and can be accessed from inside the hopper for annual maintenance or replacement (if necessary).

Photoeye Access Inside Hopper

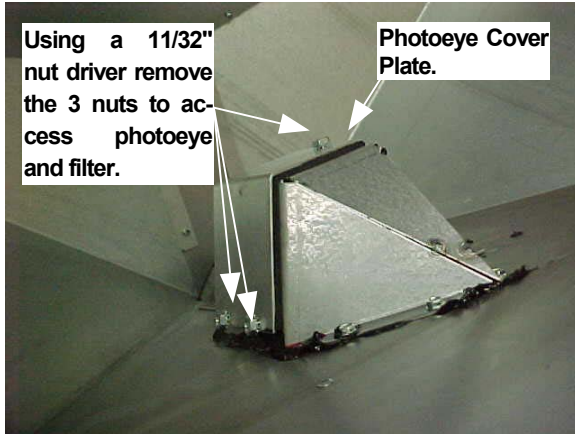

* (Minimum frequency of 6 months to 1 year)

Annual Maintenance Procedure:

Clean Photoeye Lens:

1. To access photoeye, remove cast top by lifting off, then remove the 3 nuts on the cover plate (see picture above).
2. Lift off cover plate and turn over (the photoeye is attached to the inside surface of cover). Wipe away any dust or debris from the photoeye lens (see following picture).



Remove Filter and Wipe Clean

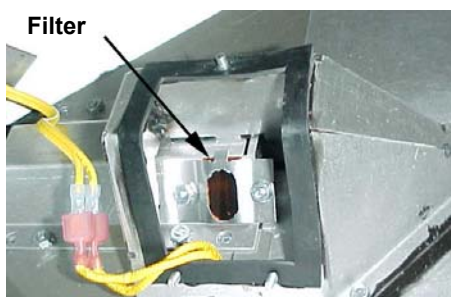

Clean Filter Lens:

1. With the photoeye cover plate removed, look inside the opening. You will see an amber colored square glass filter secured in place by a bracket and 2 nuts (it is on the left when viewed while facing the front of the stove). Using a 11/32" nut driver, remove the 2 nuts and lift off the bracket. Using your finger slide filter up and out.
2. Wipe away any dust or debris from filter, then reinstall filter, filter bracket and cover plate with photoeye.

IMPORTANT: When reinstalling photoeye and cover, be careful not to bend bracket or damage wires. Pay special attention in positioning wires away from photoeye (which could obstruct it from sensing light).

* (Minimum frequency of 4 weeks - 6 months)

EXHAUST PASSAGES AND VENT PIPE

Inspect frequently and clean when necessary. Fly ash will accumulate at all bends in the exhaust system.

Note: Large amounts of fly ash build-up will create a lack of combustion air. Removing the Tee cap on vertical installations will allow an inspection of the ash build-up in the exhaust Tee and will help you to decide how frequently more extensive cleaning must be performed.

Rain Cap



Clean-Out Tee

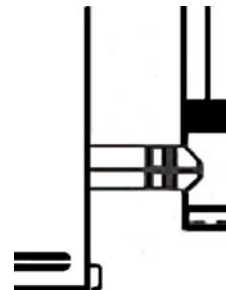

CAUTION: If the filter is not reinstalled, refractive light in the room may result in a fault, thus shutting down of the unit.

ROUTINE MAINTENANCE

Clean-Out Tee w/ Cover Removed

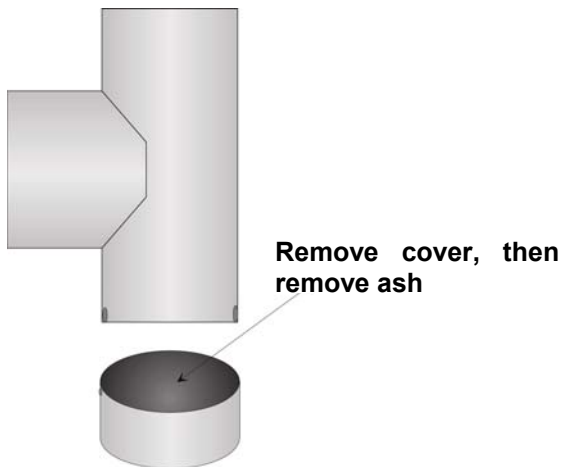

* (Minimum Frequency of 1-2 months)

Tube Scraper

Use the hole in the handle of the grate scraper tool to "grab" onto the rod



Pull the rod up and out towards the opening of the firebox

HEAT EXCHANGER TUBES

ONLY CLEAN HEAT EXCHANGER TUBES AFTER STOVE HAS COOLED DOWN. A rod is located above the heat exchange baffle (inside of firebox) is used for cleaning the tubes. After opening the firebox door, use the hole in the handle of the grate scraper tool to "grab" onto the rod (see pictures on this page). Using the grate scraper tool, pull the rod up and out towards the opening of the firebox. Continue pulling until the tube scraper reaches the top of the firebox.

It may be easier to clean the tubes by first removing the heat exchanger baffle. Loosen the two screws holding the baffle in place (do not fully remove). The baffle contains keyhole slots allowing the screws to remain in place while removing the baffle. The scraper can now be pulled in a more horizontal manner, which allows the scraper to move more freely.



* (Recommended Frequency of 2 days – 2 weeks)

ROUTINE MAINTENANCE

DOOR ROPE GASKET

The condition of the rope gasket around the door and windows should be checked periodically and replaced or repaired if necessary. A one-inch strip of paper may be used to perform a test of the integrity of the door seal. Close the door on the paper in several different locations and pull. It is normal to feel only a slight amount of friction. The door gasket does not need to be "tight" in all areas, since a small amount of leakage is not hazardous or detrimental to the performance of your stove.

Door Rope Gasket
(check seal at points indicated)

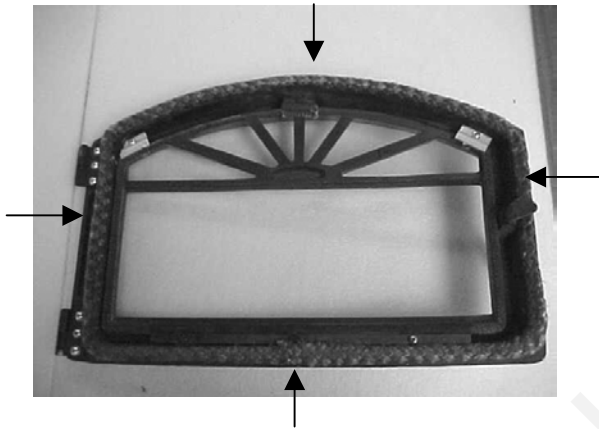

* (Recommended Frequency of 1 year)

Checking Door Seal

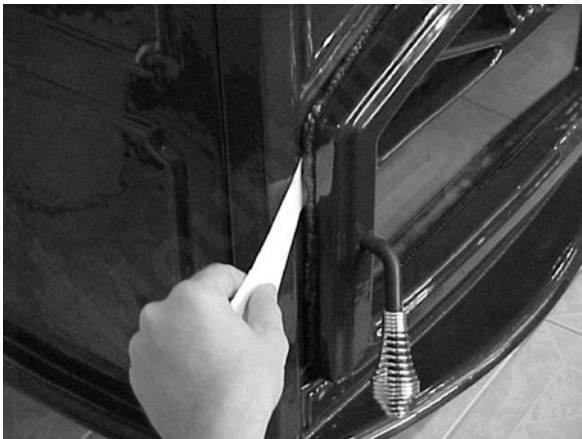

Important Note: Paper should be no longer than a dollar bill.

* (Recommended Frequency of 1 year)

WINDOW WASH

Periodically insert a small piece of cardboard (a business card) between the window trim and the window. Slide the card back & forth a few times to clear any dust or fibers from the window wash gap. Open the door and repeat from the other side of the glass.

Window Wash



* (Recommended Frequency of 1 year)

REAR STOVE COMPARTMENT

The rear stove compartment should be cleaned periodically (a minimum of once a year). **DISCONNECT ELECTRICAL CORD PRIOR TO CLEANING STOVE.** Any household dust, pet hair or sawdust should be vacuumed or wiped out of the rear compartment of the stove, room air blower, and Exhaust Blower (paying special attention to vacuuming out the intakes of both blowers). The electrical components should be wiped clean.

MOTOR LUBRICATION

The blowers are permanently lubricated by the manufacturer. Do not apply oil to any part of the blower. Doing so may cause damage.

SMALL AREA PAINT TOUCH-UP (Model T300P only)

Using one small piece of 320 grit sand paper and lightly sand the blemish so that the edges are "feathered" or smooth to the touch between the painted and bare surfaces. Do not let the sand paper gum up with paint, as this will cause scratches on the metal surface. If there are any scratches, use 600 grit sandpaper instead. Mask off surfaces you do not want painted. Paint lightly over the bare surface first as this will act as an undercoat. Then paint over a larger area in smooth even strokes to blend.

SPECIFICATIONS - Model T300P Series

Flue Size	3" / 76mm Rear
Width, Overall	28 3/4" / 730 mm
Depth, Overall	26 1/2" / 660 mm
Height	28 3/4" / 730 mm
Floor to Rear Flue Center	8 3/4" / 222 mm
Facing Back of Unit, Outside Edge of Left Leg To Center of Rear Flue Outlet	10 1/2" / 267 mm
Floor to Rear Outside Air Inlet	10" / 254 mm
Facing Back of Unit Outside Edge of Left Leg To Center of Air Inlet	17 1/2" / 445 mm
Floor Protection Requirements	+ Front and Sides: 6"/152mm Back: Up to 6" / 152mm
Standard Features	Fastfire Self Igniter Wall Thermostat (wire included)
Hopper Capacity	50 lbs.
Burn time	◆ 14-34 hours
Fuse, Control Board Fuse, Igniter	5 amp, 25 volt, 3AG* 6 amp, 125 volt*
Heat Input (Max.)	◆ 13,000-32,000 BTU / hr
Overall Efficiency	85%
Emissions	◆ 0.43 gram / hr (varies w/ size and type of fuel) EPA exempt
Ship Weight	363 lbs.
Room Air Blower	150 CFM; 1.5 amps, 2175 rpm
Auger Motor	1 RPM; .4 amps
Exhaust Blower	95 CFM: 1.0 amps, 2880 rpm

Note: Dimensions shown are approximations only (+/- 1/4")

BACK VIEW

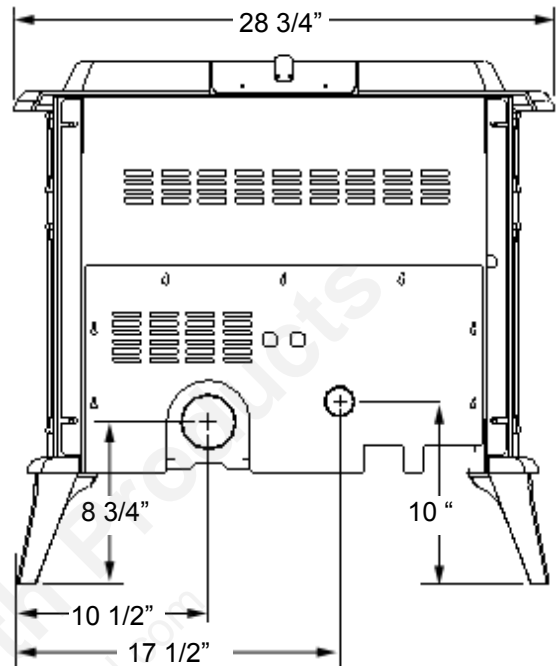

SIDE VIEW

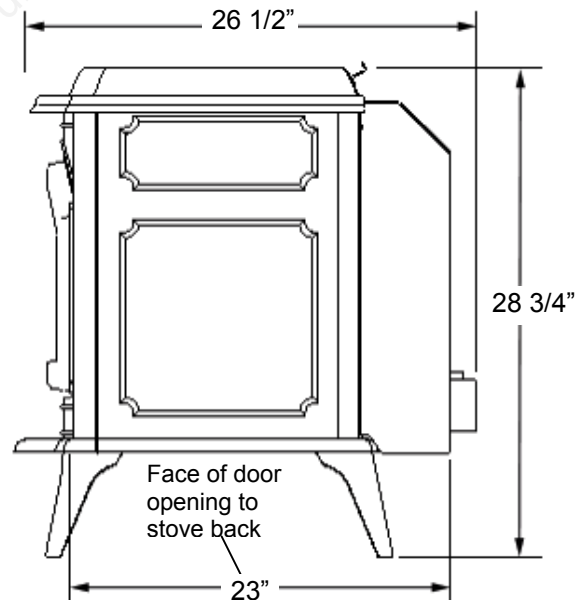

+ **Non-combustible thermal rated floor protection must be used when installed on carpet (see *Floor Protection*, page 5). When installed at clearances less than 6", the floor protector is only required to extend to the wall.**

◆ **Fuel delivery and burn times will vary depending on size and type of fuel used. Estimated heat input based on fuel value of 8400 BTU per lb.**

* **Fuses are rated as fast blow.**

DEFINITIONS

AIR WASH

To inhibit buildup of soot on the door glass, air is delivered to the glass through an air wash system located in the doorframe surrounding the glass.

AUGER

It transfers the fuel down the burner tube into the burn grate.

AUGER MOTOR

Drives the Auger. Motor specifications are: .4 Amp, 1 rpm (revolutions per minute).

BLOWER, ROOM AIR (CONVECTION)

The blower function is to transfer the heat from the appliance to heat the room air.

BLOWER, EXHAUST (DRAFT INDUCER/COMBUSTION)

It has a radial impeller to deliver more air to the burn grate. It pulls air into the burn grate by creating a negative pressure. This is done by extracting the exhaust gases out of the firebox and pushing the exhaust downstream to the flue exit.

DISC, HIGH LIMIT (L250-30F, N / C)

There are 2 of these high limit discs on this model. If a temperature reaches 250° F., the high limit auto reset will "trip" and stop the flow of electricity to the auger motor. The discs will not automatically reset until it has cooled below 220° F).

Disc for Room Air Blower – This disc is located on the Room Air Blower jacket and is designed to detect an overfire condition.

Disc for Combustion Air Inlet – This disc is located on the combustion air inlet and is designed to detect reversed flow. If negative pressure in the dwelling (i.e. An extremely tight house which may not supply adequate combustion and ventilation air) causes the exhaust to pull back from the combustion air inlet, the heat from the exhaust will result in heat activation of this disc.

HOPPER

The hopper is where the pellets are stored.

HEAT OUTPUT BUTTON

This is the main power button, which controls power to the feed system auger motor and exhaust blower. It has 3 feed rate settings, which controls the burn rate.

PHOTOEYE

The photoelectric eye that senses the flame, or lack of. It is designed to signal the control board to discontinue power to the auger motor if it flame is not sensed in the UltraGrate™.

PRESSURE SWITCH

A safety device used to shut off the feed system (auger motor) if there is too much back pressure in venting system. Some possible causes are as follows:

- ◆ The venting system is obstructed.
- ◆ High altitude or other misc. environmental conditions affecting exhaust flow.
- ◆ Improper venting system.

ULTRAGRATE™ (BURN GRATE)

This is where combustion occurs and may be referred to as the "burn grate".

WIRING DIAGRAM

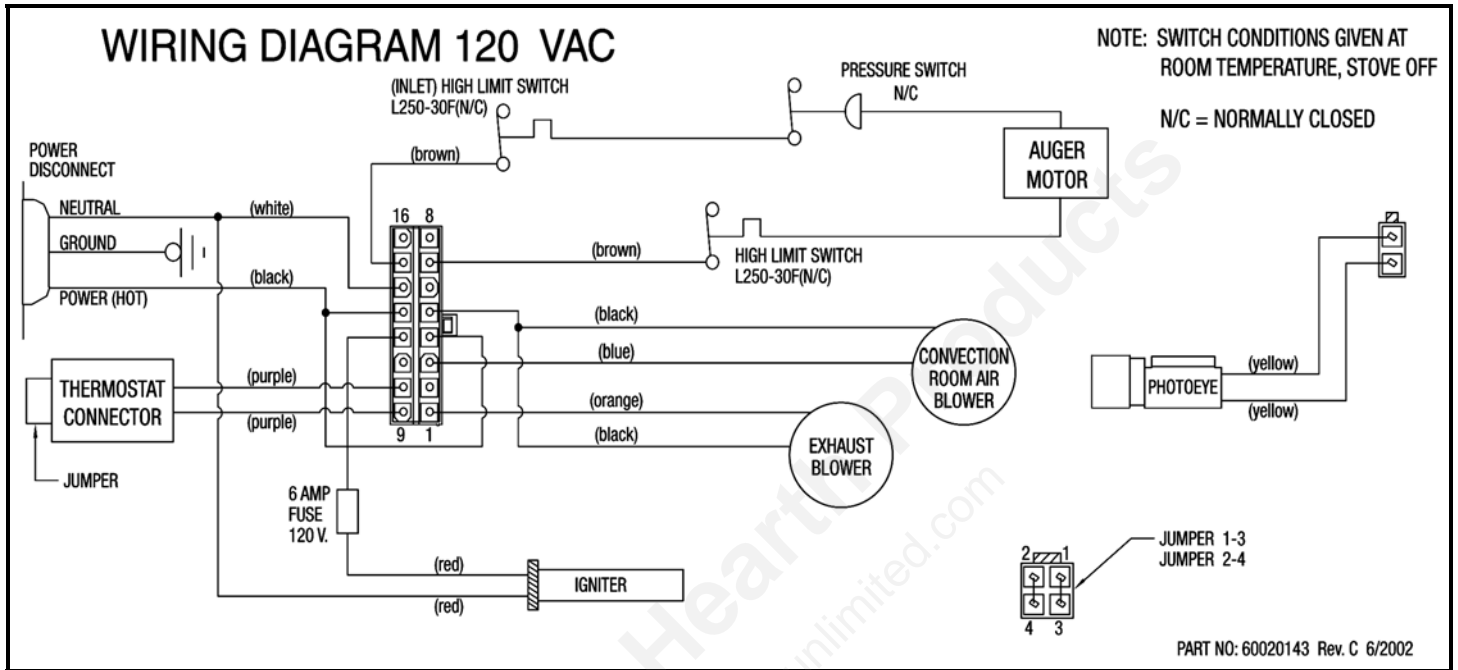

Terminal Block

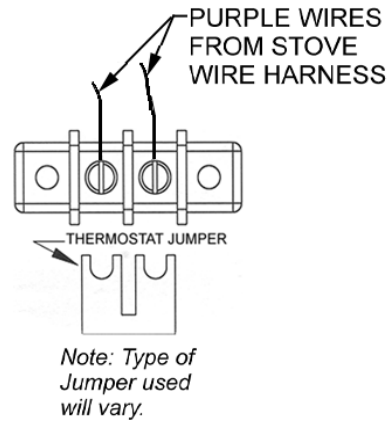
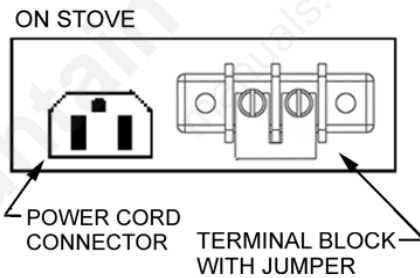

TROUBLESHOOTING (Qualified Technicians *Only*)

Unplug Appliance Before Performing Any Troubleshooting or Maintenance

PROBLEM	CAUSE(S)	SOLUTIONS
1. Fire burns with a lazy orange flame. Pellets build up in the grate and the window gets sooted up.	There is insufficient combustion air.	<p>Remove any clinkers or ash from the bottom of the grate that might be obstructing the primary air holes.</p> <p>Change to a better grade of fuel if necessary.</p> <p>Check that the damper has been opened enough for the amount of fuel feed.</p> <p>Check that the heat exchange tubes are not coated with ash.</p> <p>Clean internal exhaust ducts.</p> <p>Check gasket seal around the door. Use a thin strip of paper, 1 in. wide. Open the door and close it on the paper strip. A slight friction should be felt when the paper strip is pulled. Repeat this process at various locations around the door gasket. Replace the door gasket if necessary.</p> <p>Check for blockage in the air inlet tube or exhaust pipe. Clean as necessary.</p> <p>Close ash slide plates.</p> <p>Have your authorized Lennox Hearth Products dealer check your Exhaust Blower.</p>
2. Fire goes out or stove shuts down automatically	<p>The hopper is empty</p> <p>Pellets are not feeding.</p> <p>The high limit temperature switch has tripped.</p> <p>There is too much combustion air for the amount of fuel.</p>	<p>Refill hopper.</p> <p>See <i>Pellets will not feed</i> (#3) below.</p> <p>Allow stove to cool for 1 hour and re-light. If the stove has been operating at a medium to high burn rate and the room air blower has been turned down low then the fan should be turned up higher. If this problem persists (particularly at lower burn rates) then the high limit disc should be replaced by your authorized Lennox Hearth Products dealer.</p> <p>Adjust the damper to reduce combustion airflow.</p>
3. Pellets will not feed.	<p>Stove has run out of fuel.</p> <p>The auger motor or circuit board may be defective. The pressure switch tap or hose may be blocked.</p> <p>Back pressure in venting tripping pressure switch.</p> <p>Thermostat is in stand-by mode.</p> <p>Thermostat wires disconnect.</p> <p>High limit switch may have been tripped.</p> <p>Self-aligning bearing in auger motor may be mis-aligned.</p>	<p>Refill hopper.</p> <p>Check to be sure that there is no blockage in the pressure tap or hose. Have your authorized Lennox Hearth Products dealer diagnose the problem and clean or replace any necessary parts.</p> <p>If new installation check for excessive 90° bends, long horizontal runs or excessive vertical run of 3" pipe. Possibly change to 4" pipe. If older installation check for excessive ash accumulation in pipe or other obstructions. Clean out pipe.</p> <p>Check to see if thermostat is set to low or if sun is shining directly on thermostat.</p> <p>Re-install wires.</p> <p>Allow stove to cool. Increase room air blower setting.</p> <p>Gently tap the auger motor.</p>

TROUBLESHOOTING (Qualified Technicians *Only*)

Unplug Appliance Before Performing Any Troubleshooting or Maintenance

PROBLEM	CAUSE(S)	SOLUTIONS
4. Blowers will not operate when the start switch is depressed.	There is no power to the stove. There is no power to the control board.	Check that the stove is plugged in to the wall outlet. Check to see if your circuit breaker has tripped. Check the wire connections on the high limit disc and Control board.
5. There is soot or fly ash in the house.	The window is being cleaned when the stove is operating. There is leakage at the joints between the exhaust blower, connection or exhaust pipe connections. This will be evidenced by dust on the impeller of the room air blower, and in the heat exchanger area. The vacuum cleaner is leaking.	Turn down the room air blower or turn off stove before cleaning to prevent dispersion of ash and soot into the room. Seal up any leaks in the exhaust system with room temperature vulcanizing silicone sealer (RTV). DO NOT use a standard household vacuum or "shop vac" as the filters will leak the fine particles of ash. Clean the stove with an approved ash vacuum ONLY.
6. Stove acts as if a fire is present when there is not a fire in the grate.	Excessive sun light may be shining directly into firebox from window.	Block excessive sunlight. Call your authorized Lennox Hearth Products dealer if problem persists.
7. Stove will not light.	The igniter element may have failed. There are not enough pellets in the UltraGrate™.	Check igniter element fuse in rear stove compartment. Call your authorized Lennox Hearth Products dealer. See alternate manual lighting procedure Prime the feed system (see page 18, Initial Start Up/Empty Hopper or Feed Tube).
8. Fault	Photoeye not detecting flame. Stove has run out of fuel. A disk has tripped / pressure switch.	Clean photoeye lens (<i>see Clean Photoeye Lens</i> on page 23.) Check connection at control board following yellow wires to all connectors. Refill hopper. Blower intake, exhaust passages and / or venting system needs cleaning (follow routine and annual maintenance procedures). If this does not correct the problem contact your local authorized Lennox Hearth Products dealer.

REPLACEMENT PARTS LIST

Door Parts & Body Components

Item #	Part #	Description
1	20953002	Door Assembly, Black Painted – Model T300P
1	20953012	Door Assembly, Black Enamel – Model T301P
1	20953052	Door Assembly, Green Enamel – Model T305P
1	20953082	Door Assembly, Sand Enamel – Model T308P
	26M81	Gasket Kit, Door, 3/4" Rope (10' of 11547)
	61057208	Gasket Kit, Glass (4')
	20M44	Cast Top, Black Painted – Model T300P
	20M49	Cast Top, Black Enamel - Model T301P
	20M54	Cast Top, Green Enamel – Model T305P
	20M59	Cast Top, Sand Enamel – Model T308P
	26M18	Hinge Pin Set
2	20950005	Handle Assembly, Door
	20959999	Glass, Door (includes gasket)
3	20950205	Hopper Lid Assembly, Kit
	20950091	Ash Pan Assembly
	20751075	Leveler Legs, 2 pc. (for a complete set of 4 levelers, order 2 kits)
4	20950100	Rear Panel Assembly
	20953006	Trivet, Black

Electrical Parts

Item #	Part #	Description
5	12046300	Auger Motor
6	16055150	Control Board
7	12050011	Exhaust Blower (combustion fan))
8	12146109	Room Air Blower (includes gasket and 4 nuts)
9	12147705	High Limit Disc, 250 DG (L250-30F, 60T21) Set of three
10	12150213	Igniter Probe, 380 W, 3.3 A
11	14750404	Photoeye Kit, Replacement (w/bracket) - (Serial #5493 and up)
12	12058820	Power Cord (52L17)
13	16050001	Pressure Switch
14	16050205	Thermostat, Wall, Honeywell (Thermostat Wire, P/N 16020204, is not included)
	16020204	Wire, Thermostat, 20' coil - 18 gage
15	12050815	Wiring Harness
	18150150	Fuse, Control Board, 5 amp, 250 volt, Fast blow, 12pk.
	12055908	Fuse, Igniter, 6 amp, 125 volt, Fast blow, 12pk.

Firebox Parts

Item #	Part #	Description
16	20950155	Brick Clips (2 clips)
17	20950150	Firebrick Set
18	12051263	UltraGrate™, Replacement

REPLACEMENT PARTS LIST

Auger

Item #	Part #	Description
20	12041300	Collar & Screw Set, Auger (3pc.)
21	20950087	End Flange, Auger
22	61050003	End Plate Gasket, Auger (5pc.)
23	11756300	Shaft, Auger

Misc. Parts

Item #	Part #	Description
	17150029	Damper Rod Assembly, Kit
24	20950110	Gasket, Quick Disconnect
25	20950014	Baffle, Heat Exchange
27	12055500	Tool, Grate Scraper
	12121413	Knob, Ash Pan
	26022H	Touch Up Paint, Black (for enamel)
	26021H	Touch Up Paint, Green (for enamel)
	26023H	Touch Up Paint, Sand (for enamel)

REPLACEMENT PARTS DIAGRAMS

1

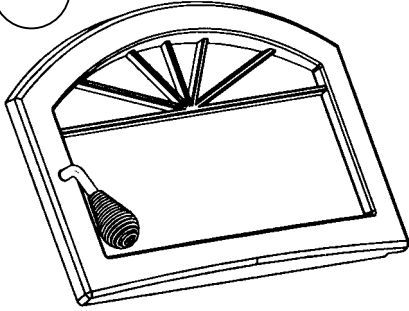

2



3

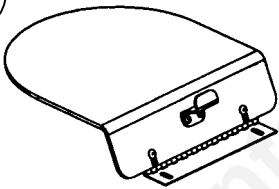

4

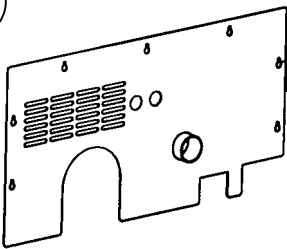

5

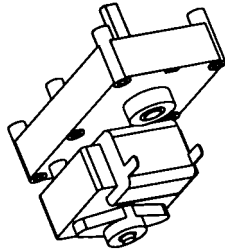

6

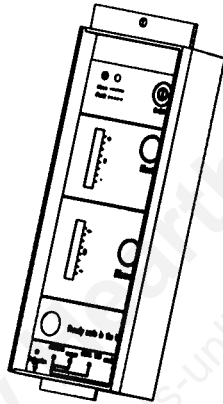

7

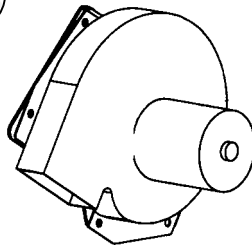

8

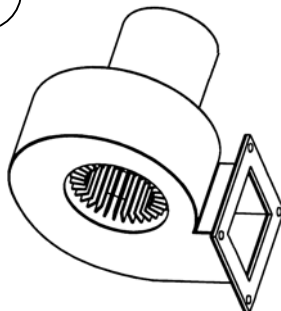

9

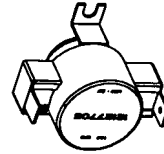

10

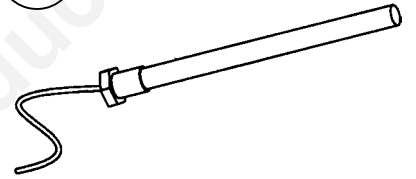

11

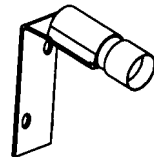

12

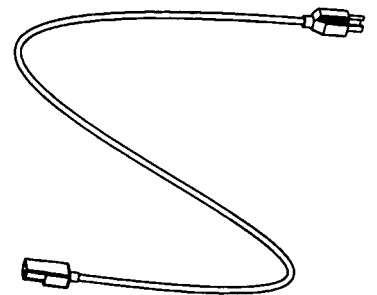

REPLACEMENT PARTS DIAGRAMS

13

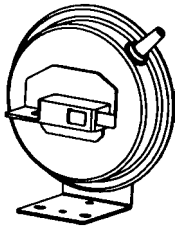

14

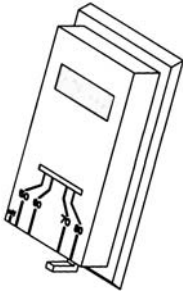

15

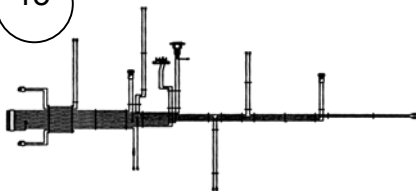

16

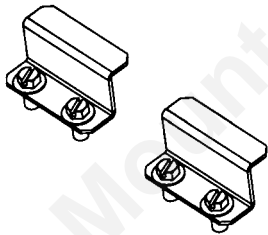

17

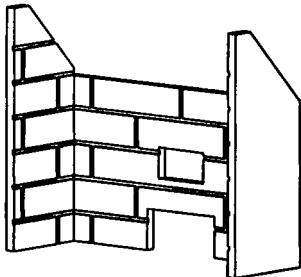

18

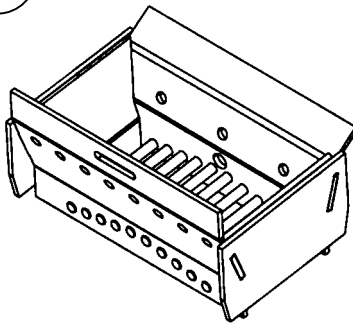

20

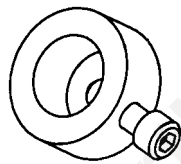

21

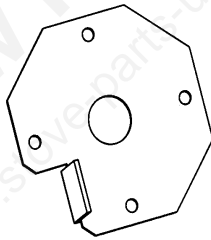

22

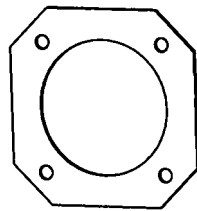

23

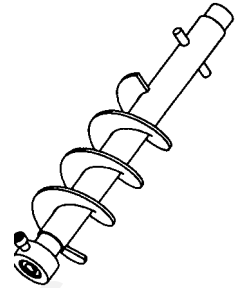

24

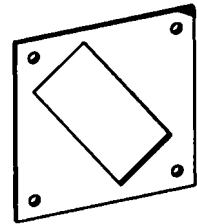

25

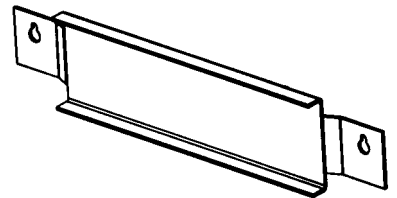

27

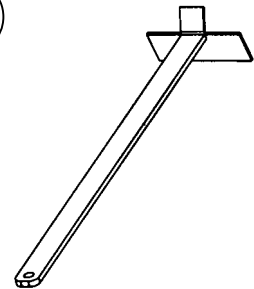

OPTIONAL ACCESSORIES

Note: Install and use accessories per instructions provided with the accessory kit.

Optional Accessories

Item #	Catalog #	Model #	Description	Notes
1	14M16	TT – G	Trivet, Gold Plated	Replaces Standard Cast Black Trivet
2	H0252	DLS – T30	Log Set	2 Piece
3	14M81	QDPC – 4	Quick Disconnect Pipe Connector, 4"	Required if 4" Pipe is used
	70K99	TSPK – B	Touch-up Spray Paint Kit, Black	Metallic Black 12oz Spray Can

1

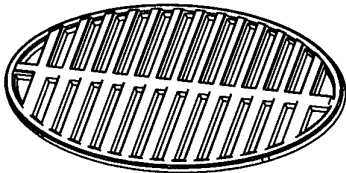

2



3

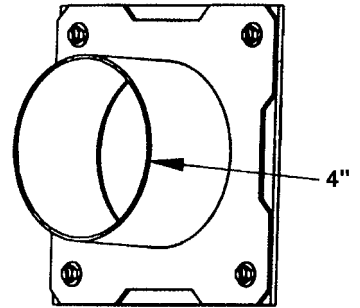

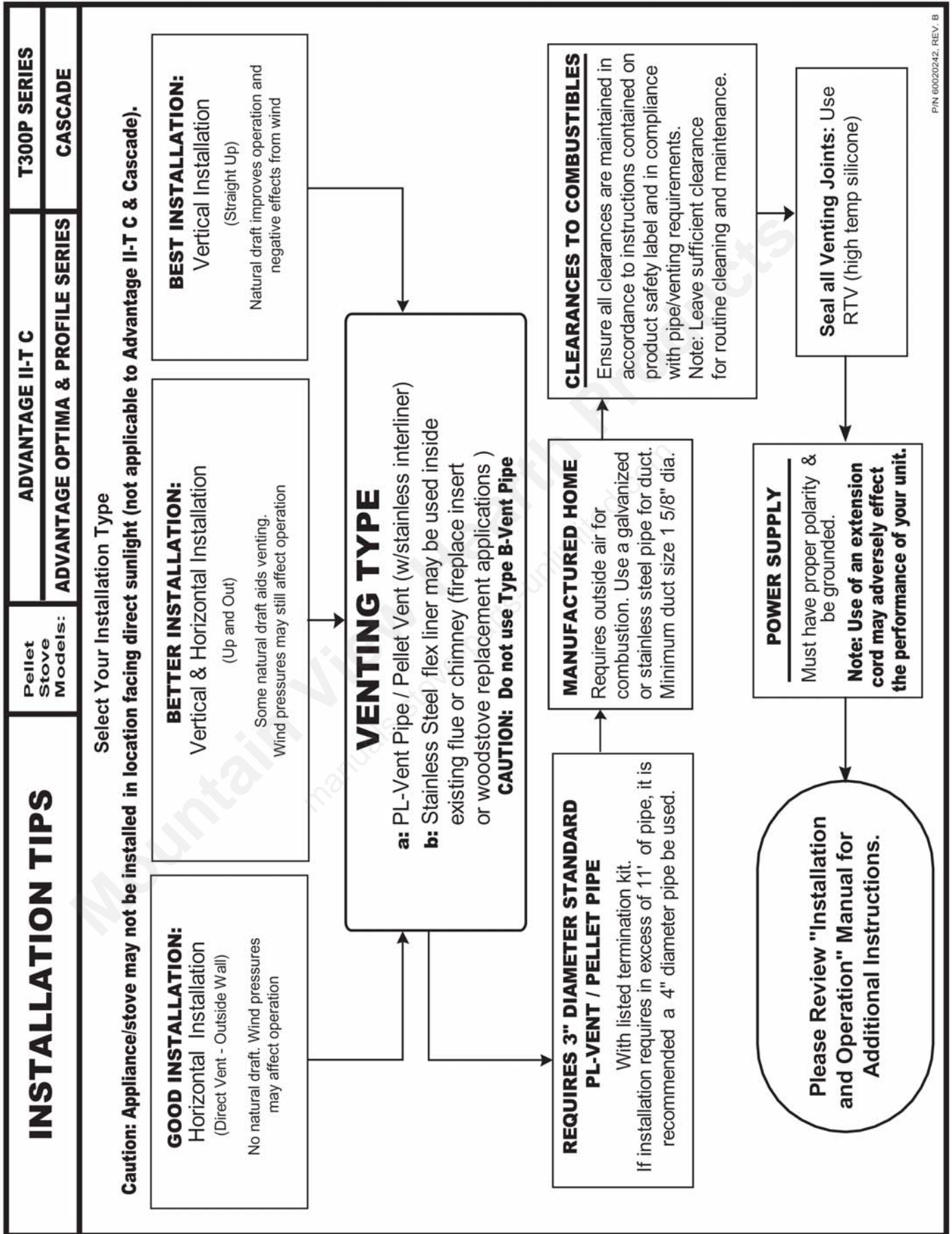

SIMPLE OPERATING INSTRUCTIONS LABEL

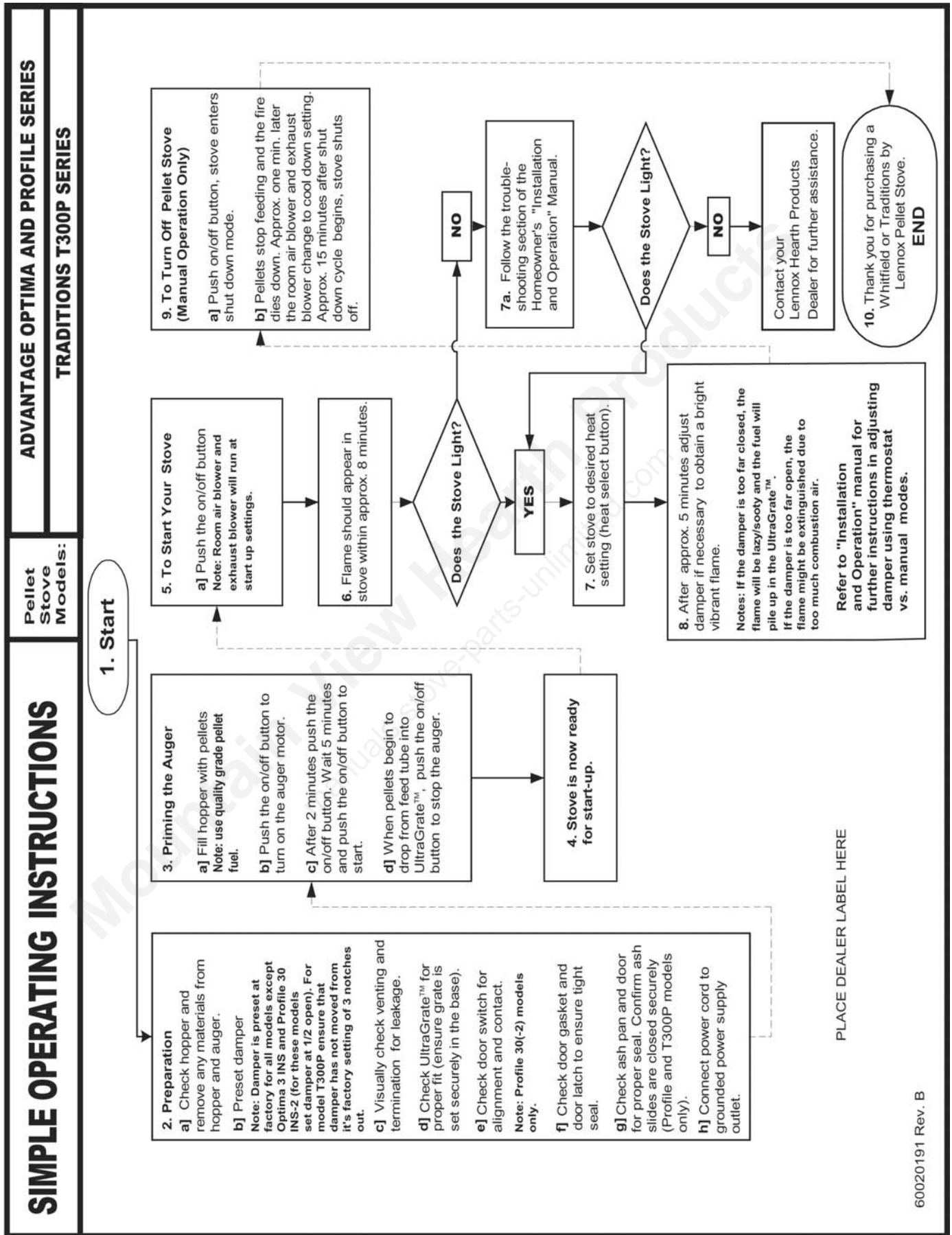

T300P PELLET STOVE SAFETY LABEL

Note that your serial number is printed on the safety label located on the back of the stove. Your stove's serial number is preceded by a "WH-" (Example WH-000000).

Warnock Hersey
C H US

CERTIFIED FOR U.S. AND CANADA. LISTED ROOM HEATER FOR USE WITH APFI/FFI APPROVED PELLETIZED WOOD FUEL ONLY. FOR USE IN MANUFACTURED (MOBILE) HOMES. **MODEL: T300P SERIES** TESTED TO ASTM E-1509 / UL 1482 / ULC-S627 / ULC-S628 REPORT NO. 476-1773 -1/02 (JULY 2002).

INSTALL AND USE ONLY IN ACCORDANCE WITH THE MANUFACTURER'S INSTALLATION INSTRUCTIONS. CONTACT LOCAL BUILDING OR FIRE OFFICIALS ABOUT RESTRICTIONS AND INSTALLATION INSPECTION IN YOUR AREA. DO NOT CONNECT THIS UNIT TO A CHIMNEY FLUE SERVING ANOTHER APPLIANCE. SEE LOCAL BUILDING CODE AND MANUFACTURER'S INSTRUCTIONS FOR PRECAUTIONS REQUIRED FOR PASSING A CHIMNEY THROUGH A COMBUSTIBLE WALL OR CEILING. THIS PELLET FIRED APPLIANCE HAS BEEN TESTED AND LISTED FOR USE IN MANUFACTURED HOMES IN ACCORDANCE WITH OREGON ADMINISTRATIVE RULES 814-23-900 THROUGH 814-23-909.

OPERATE ONLY WITH FIREBRICK IN PLACE. WARNING: OPERATE ONLY WITH VIEWING DOOR CLOSED. INSPECT FLUE FREQUENTLY TO PREVENT ACCUMULATION OF SOOT. THE HEATER AND FLUE MUST BE IN GOOD CONDITION. KEEP FURNISHINGS AND OTHER COMBUSTIBLE MATERIALS WELL AWAY FROM HEATER.

ROUTINE MAINTENANCE REMINDER

FREQUENCY OF CLEANING AND MAINTENANCE OF YOUR STOVE DEPENDS ON THE ASH CONTENT OF THE PELLETS YOU BURN. CHECK THE FOLLOWING PARTS OF YOUR STOVE WEEKLY FOR THE FIRST MONTH TO DETERMINE THE FREQUENCY OF CLEANING.

A. BURN GRATE
B. HEAT EXCHANGER TUBES
C. ASH PAN AND EXHAUST PIPE

SEE YOUR MANUAL AND/OR DEALER FOR MORE INFORMATION.
INPUT RATING RANGE: 1.5 TO 3.8 LBS./HOUR (NOMINAL)
ELECTRICAL RATING: 60 HZ, 115 V, LESS THAN 10 AMP

DO NOT REMOVE THIS LABEL

NUMÉRO DE SÉRIE / SERIAL NO.

WH-

MINIMUM CLEARANCES TO COMBUSTIBLE MATERIALS

FREESTANDING STOVE INSTALLATION	MANUFACTURED (MOBILE) HOME OR RESIDENTIAL INSTALLATION	
	HORIZONTAL FLUE- DIRECTLY THROUGH-WALL INSTALLATION	INTERIOR VERTICAL FLUE INSTALLATION
SIDEWALL TO UNIT	A 6"/153 MM	6"/153 MM
BACKWALL TO UNIT	B 2"/51 MM	9"/229 MM
WALL TO UNIT CORNER	C 2"/51 MM	2"/51 MM
ALCOVE TO CAST TOP	D 6"/153 MM	6"/153 MM
MAX. DEPTH OF ALCOVE FLUE TO WALL	E 18"/458 MM	18"/458 MM
FRONT/REAR/SIDE TO FLOOR PROTECTION OUTSIDE EDGE	F N/A	3"/77 MM
	I 6"/153 MM	6"/153 MM
	MINIMUM ALCOVE HEIGHT 48"/1220 MM	
	MINIMUM ALCOVE WIDTH 41"/1042 MM	

T300P Series

DO NOT REMOVE THIS LABEL

CAUTION: HOT SURFACES WHILE IN OPERATION. DO NOT TOUCH. CONTACT MAY CAUSE SKIN BURNS.

KEEP CHILDREN, COMBUSTIBLE MATERIAL AND FURNISHINGS A CONSIDERABLE DISTANCE AWAY. SEE NAMEPLACE AND INSTRUCTIONS. TYPE OF FUEL: PELLETIZED WOOD FUEL ONLY.

COMBUSTIBLE FLOOR MUST BE PROTECTED BY NON-COMBUSTIBLE MATERIAL EXTENDING BENEATH THE HEATER AND 6" TO THE FRONT, SIDES AND REAR AS INDICATED OR TO THE NEAREST PERMITTED COMBUSTIBLE MATERIAL.

USE 3" / 75mm or 4" / 100mm Type "PL" LISTED PELLET VENT AND COMPLETE COMPONENTS.

T300P Series

TRADITIONS
BY LENNOX HEARTH PRODUCTS

Manufactured by:
Lennox Hearth Products
1110 West Taft Avenue
Orange, CA 92865

ATTENTION : SURFACES CHAUDES DURANT LE FONCTIONNEMENT DE L'APPAREIL. NE PAS TOUCHER. UN CONTACT PEUT CAUSER DES BRÛLURES CUTANÉES. TENIR LES ENFANTS, LES MATÉRIEAUX COMBUSTIBLES ET L'AMEUBLEMENT À UNE DISTANCE CONSIDÉRABLE DE L'APPAREIL. VOIR LA PLAQUE SIGNALÉTIQUE ET LES DIRECTIVES. TYPE DE CHAUFFAGE : BOIS DE CHAUFFAGE GRANULÉ SEULEMENT.

LE PLANCHER SUR LEQUEL REPOSE L'APPAREIL DOIT ÊTRE PROTÉGÉ PAR UN MATÉRIAU NON COMBUSTIBLE QUI COUVRE LA PARTIE SOUS L'APPAREIL ET 6 PO À L'AVANT, AU DERRIÈRE ET SUR LES CÔTÉS SELON LES INDICATIONS DONNÉES OU JUSQU'À L'ENDROIT PERMIS LE PLUS PRÈS POUR LES MATÉRIEAUX COMBUSTIBLES.

UTILISER UN ÉVENT POUR GRANULES RÉPERTORIÉ «L» DE 3 po/75 mm ET DES COMPOSANTS COMPLETS.

T300P Series

TRADITIONS
BY LENNOX HEARTH PRODUCTS

Fabriqué par:
Lennox Hearth Products
1110 West Taft Avenue
Orange, CA 92865

NE PAS ENLEVER CETTE ÉTIQUETTE DÉGAGEMENT MINIMUM POUR LES MATÉRIAUX COMBUSTIBLES

INSTALLATION DU POÊLE AUTONOME	INSTALLATION RESIDENTIELLE OU DANS UNE MAISON PRÉFABRIQUÉE (MOBILE)	INSTALLATION INTERIEURE DU CONDUIT DE FUMÉE À LA VERTICALE
DU MUR LATÉRAL À L'APPAREIL	A 6 po/153 MM	6 po/153 MM
DU MUR ARRÉRIÈRE À L'APPAREIL	B 2 po/51 MM	9 po/229 MM
DU MUR AU CORN DE L'APPAREIL	C 2 po/51 MM	2 po/51 MM
DE L'ALCOVE À L'ENTONNOIR DU BOIS DE CHAUFFAGE	D 6 po/153 MM	6 po/153 MM
PROFONDEUR MAX. DE L'ALCOVE DU CONDUIT DE FUMÉE AU MUR DE L'AVANT, L'ARRIÈRE ET LES CÔTÉS AU PLANCHER BORD EXTÉRIEUR DE PROTECTION	E 18 po/458 MM	18 po/458 MM
	F N/A	3 po/77 MM
	I 6 po/153 MM	6 po/153 MM
	MINIMUM ALCOVE HEIGHT 48 po/1220 MM	
	MINIMUM ALCOVE WIDTH 41 PO/1042 MM	

T300P Series

DO NOT REMOVE THIS LABEL

Mountain View Hearth Products
manuals.stove-parts-unlimited.com

LENNOX[®]

HEARTH PRODUCTS

1110 West Taft Avenue

Orange, CA 92865