

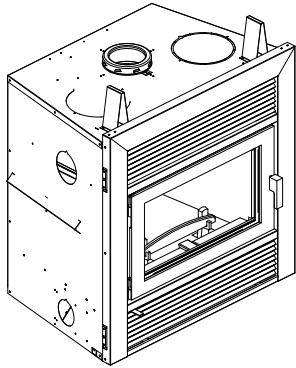

INSTALLATION AND OPERATION INSTRUCTIONS

Brentwood™ LV



Shown with louver kit installed

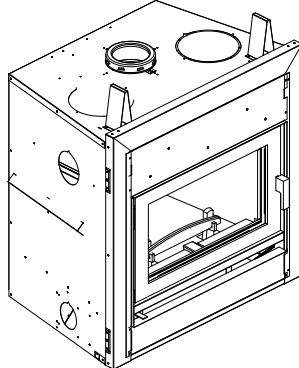

Shown with clean face kit installed

A French manual is available upon request. Order P/N 900096-00.

Ce manuel d'installation est disponible en français, simplement en faire la demande. Numéro de la pièce 900096-00.

EPA Wood-Burning Fireplaces
P/N 900095-00 REV. D 08/2018

MODEL

Brentwood LV

This installation manual will enable you to obtain a safe, efficient and dependable installation of your fireplace system. Please read and understand these instructions before beginning your installation.

Do not alter or modify the fireplace or its components under any circumstances. Any modification or alteration of the fireplace system, including but not limited to the fireplace, chimney components and accessories, may void the warranty, listings and approvals of this system and could result in an unsafe and potentially dangerous installation.

IHP wood-burning fireplaces are designed for use as a supplemental heater. They are not intended for continuous use as a primary heat source.

THIS UNIT REQUIRES THE INSTALLATION OF A FINISHING KIT. SEE "PARTS REQUIRED" SECTION FOR DETAILS

**Fireplace, Also For Use In
Manufactured Homes With Solid Fuel Only.**

**SAVE THESE INSTRUCTIONS
FOR FUTURE REFERENCE**

 **WARNING**

- Hot! Do not touch! The glass and surfaces of this appliance will be hot during operation and will retain heat for a while after shutting off the appliance. Severe burns may result.
- Carefully supervise children in the same room as appliance.



- If small children are present in the home, it is recommended that this appliance be fitted with an adjustable safety gate or barrier screen.

 **WARNING**

- The fireplace cannot be operated without a door or firescreen. Consult your dealer to select the correct door or firescreen.
- Important! To assure proper alignment of glass doors: Install this fireplace in a square and plumb condition, using shims as necessary at sides and/or bottom.
- Install the fireplace only as described in these instructions.

 **WARNING**

This product can expose you to chemicals including Carbon Black, which is known to the State of California to cause cancer, and Carbon Monoxide, which is known to the State of California to cause birth defects or other reproductive harm. For more information go to www.P65Warnings.ca.gov



Listed to standards:
ULC-S610 & UL-127
Report # 14-180
EPA Cert. No. 537



P900095-00

CONGRATULATIONS!

When you purchased your new wood fireplace, you joined the ranks of thousands of individuals whose answer to their home heating needs reflects their concern for aesthetics, efficiency and our environment. We extend our continued support to help you achieve the maximum benefit and enjoyment available from your new wood fireplace.

Thank you for selecting a IHP wood fireplace as the answer to your home supplemental heating needs.

TABLE OF CONTENTS

Introduction	Page 2
Parts Required	Page 2
Optional Equipment.....	Page 2
SAFETY RULES and Specifications for Mobile or Manufactured Home Installation.....	Page 3
Operating The Fireplace	Page 4
Fuel	Page 4
Combustion Control	Page 4
Refueling For Best Performance	Page 5
Smoking – Causes And Troubleshooting	Page 5
Important Cautions	Page 5
Maintaining Your Brentwood™ LV Fireplace.....	Page 6
Chimney Maintenance.....	Page 6
Dealing With A Chimney Fire.....	Page 6
Finish Door Casing Care.....	Page 6
Disposing of Ashes	Page 6
Refractory Installation.....	Page 7
Door Installation	Page 7
Door Adjustment.....	Page 7
Glass Care - Replacement	Page 8
Glass Care - Cleaning	Page 8
Gasket Replacement	Page 8
Fireplace Installation	Page 8
Locating The Brentwood LV Fireplace ..	Page 8
Installing The Finishing Kits	Page 9
Framing, Facing And Mantel.....	Page 10
Hearth Extension Requirements	Page 10
Cold Climate Installations.....	Page 10
Fireplace and Framing Dimensions ...	Page 11
Insulated Chase Construction	Page 12
Nailing Flanges.....	Page 12
Facing / Mantel.....	Page 13
Hot Air Ducting Installation	Page 14
Gravity Kit	Page 14
Central Forced Air Kit	Page 15
Outside Air Kit	Page 16
Chimney System	Page 17
Chimney Installation Notes	Page 17
Chimney Installation Instructions.....	Page 18
Offset Chimney Installation	Page 19
Angled Wall Radiation Shield	Page 21
Chimney Support Installation.....	Page 22
Chimney Chase And Multiple Terminations.....	Page 22
Chimney Adaptor	Page 22
Masonry Application Instructions	Page 23
Installation Accessories	Page 24
Replacement Parts.....	Page 25
Specifications.....	Page 25
Clearance to Combustibles.....	Page 25
Chimney Components Lists	Page 27
Safety/Listing Label.....	Page 29
Warranty	Page 31
Product Reference Information	Page 32

THE FIREPLACE INTRODUCTION

The Brentwood™ LV wood-burning fireplace is an energy efficient, heat circulating, closed combustion fireplace. You will receive a lifetime of comfort and enjoyment from your fireplace provided it is installed, maintained and operated properly.

- Please read these instructions and retain this manual for future reference.
- Before beginning the fireplace installation, consult the local authorities to obtain your building permit and check your local building codes. Install the fireplace only as described in these instructions and using only IHP components.
- This fireplace has been tested for CAN/ULC S610-M87 and ANSI/UL 127 under report number 3011202. It has also been tested for EPA 40 C.F.R Part 60, section 60.532(b). Certificate number 537.
- The Brentwood LV fireplace is not intended for use with a gas log set. Do not use a fireplace insert or any other product with this fireplace unless it is specified by IHP for use with this appliance. Failure to follow these instructions will void the certification and the warranty of the fireplace and may result in an unsafe installation.
- IHP wood fireplaces are designed for use as a supplemental heater. They are not intended for continuous use as a primary heat source.

PARTS REQUIRED

Fireplace Model Brentwood LV

- **Finishing Kit - Required ***
(Order Separately)
 - Louver kitOR
 - Clean face obstruction plate kit. Must be used in conjunction with a gravity vent kit.

***SEE "INSTALLING THE FINISHING KITS" SECTION FOR THE ASSEMBLY OF THE FINISHING KITS.**

- **Black steel door - Required (included w/fireplace)**
- **Outside air kit - Required (included w/fireplace)**
- **Blower kit with thermo-disc (V2) (included w/fireplace)**
- **6" diameter chimney*** - model ASHT+, S-2100+, HT6000+, HT6103+ or AC manufactured by Security Chimneys® only, including:
 - Chimney lengths
 - Elbows (where necessary)
 - Associated components as per these installation instructions
- **6" diameter chimney **** - Model DuraTech® DTC manufactured by DuraVent® only, including:
 - Chimney lengths
 - Elbows (where necessary)
 - Associated components as per these installation instructions

OPTIONAL EQUIPMENT

- **Additional Equipment (optional)**
 - AC chimney adaptor*
(required if using AC chimney)
 - AC chimney outside air kit
 - Gravity venting system
 - Central forced air kit ❶
 - Blower speed control
 - Rigid Firescreen ❶

❶ **Not tested under EPA certification. If installed, this appliance no longer qualifies for EPA certification. Check with local authorities having jurisdiction for requirements in your area.**

IMPORTANT! GENERAL SAFETY PRECAUTIONS. READ AND UNDERSTAND THESE SAFETY RULES BEFORE YOUR FIRST FIRE.

⚠ WARNING

THE FIREPLACE MUST BE OPERATED WITH THE DOOR FULLY OPENED OR DOOR FULLY CLOSED. IF THE DOORS ARE LEFT PARTLY OPENED, GAS AND FLAME MAY BE DRAWN OUT OF THE FIREPLACE OPENING, CREATING RISKS OF BOTH FIRE AND SMOKE. IF THE UNIT IS OPERATED WITH THE DOORS FULLY OPENED, THE OPTIONAL FIRESCREEN MUST BE USED.

⚠ WARNING

NEVER use gasoline, gasoline-type lantern fuel, kerosene, charcoal lighter fluid, naphtha, engine oil or similar liquids to start or “freshen up” a fire in this fireplace. Keep any flammable liquids a safe distance from the fireplace at all times.

⚠ WARNING

THIS FIREPLACE HAS NOT BEEN TESTED WITH AN UNVENTED GAS LOGS OR A FIREPLACE INSERT. TO REDUCE RISK OF FIRE OR INJURY, DO NOT INSTALL AN UNVENTED GAS LOG SET OR FIREPLACE INSERT OR OTHER PRODUCTS NOT SPECIFIED FOR USE WITH THIS FIREPLACE.

⚠ WARNING

Never leave your fireplace unattended while it is burning.

⚠ WARNING

To avoid the risk of damaging fireplace materials and increasing the risk of fire, do not use the fireplace to cook or warm food.

⚠ WARNING

Use care when selecting window treatments for windows located near the fireplace. Avoid using combustible flowing window treatments such as curtains on nearby windows that are of sufficient length to be blown in front of an open flame when the window is opened. Keep any combustible furniture, materials or decorative pillows at least 48" (1219 mm) from the front fireplace opening.

⚠ WARNING

Never modify or alter your fireplace system in any way. To do so may create a potential fire hazard and void the limited warranty, listings and approvals of this system.

⚠ IMPORTANT

When burning wood, use SOLID NATURAL DRY WELL-SEASONED WOOD ONLY. Hardwoods are recommended (soft woods tend to burn very quickly).

- **DO NOT** burn treated wood, charcoal, coal, trash, cardboard, driftwood, woods dipped in tar, Christmas tree greens, pitch, pine tar, creosote, chemical chimney cleaners, flame colorants, polystyrene packaging, wood products with synthetic binders (i.e. plywood). Plywood, lumber and other misc. materials can produce abnormally high temperatures, sputtering and smoking fires and may contain hazardous chemicals to treat insects and fungus.

- Burning unapproved fuels can produce excessive temperatures, beyond the design capabilities of the fireplace and may produce excess sparks or may contain hazardous chemicals. Burning unapproved fuels can result in a chimney fire, a house fire, personal injury, death or loss of property.

⚠ WARNING

Never leave children unattended when there is a fire burning in the fireplace.

⚠ WARNING

Always ensure that the air inlet to the fireplace is free from debris and any other obstructions that can block the entrance of air.

⚠ IMPORTANT

WHEN INSTALLED IN A MOBILE OR MANUFACTURED HOME:

- Mobile or manufactured home installations must be installed in accordance with the requirements of the Department of Housing and Urban Development (HUD) “Mobile Home Construction and Safety standards” for US or Canada Mortgage and Housing Corporation (CMHC) for Canada.

- The fireplace must be fastened to the floor by unfolding and screwing the small tabs on both sides at the bottom of the fireplace.

- It is necessary to have access openings, for inspection purpose only, into built-in enclosures surrounding the fireplace installation. Such openings to require a household tool for access.

- The vapor barrier of the mobile home shall be as close as possible of the location where the chimney assembly penetrates the ceiling and roof structure with no interference to the required clearance to combustible material.

- When the mobile or manufactured home has a flat roof, the Attic Radiation Shield must be installed from below going through the roof (See *Figures 29b and 29d*).

- **Warning:** Do not install in a sleeping room.

- **Caution:** The structural integrity of the manufactured home floor, wall, and ceiling/roof must be maintained.

⚠ WARNING

Neither the manufacturer nor the seller warrants “smoke free” operation nor are we responsible for inadequate system draft caused by mechanical systems, general construction conditions, inadequate chimney heights, adverse wind conditions and/or unusual environmental factors or conditions beyond our control.

NOTE: DIAGRAMS & ILLUSTRATIONS ARE NOT TO SCALE.

OPERATING THE FIREPLACE

Fuel - USE SOLID NATURAL WOOD FUEL ONLY. This appliance is designed to burn dry seasoned natural wood only (see *Page 6* for a list of prohibited fuels). Failure to burn proper fuels only will void the certification and the warranty of the appliance. Hardwoods are preferred to softwoods since the energy content of wood is relative to its density. Hardwoods will result in a longer burning fire and less frequent refueling. A moisture content of 15% to 20% (seasoned) is recommended. Wood that has been cut and split and let to dry under a cover for a period of one year will usually meet that criteria. The required drying time will vary depending on the climate. Wood that is packed tight together will take longer to dry. Seasoned wood is darker in color than wet wood and will have visible cracks in the grain on the ends. Excessively wet wood will be difficult to burn and will result in lower efficiency, increased creosoting and deposits on the glass and in the chimney. Excessively dry wood will burn well but will also have higher emissions and shorter burning time.

DO NOT OVERFIRE THIS HEATER

Attempts to achieve heat output rates that exceed heater design specifications can result in permanent damage to the heater.

First Fires

Before using the fireplace make sure to remove the plastic wrapping and EPA label on door. Remove any glue residue left by the label using mild soap.

The first five or six fires should be small fires of short duration (about 30 to 60 minutes). This will help cure the refractory bricks. During the first few fires of this appliance there may be some odor and smoke due to the curing of the paint, dust accumulation and burning off of lubricants used in the manufacturing process. It may set off a smoke alarm located in the same room. For this reason the room should be well ventilated for the first few fires.

WARNING

Be careful adding wood fuel to the fire or handling fireplace tools such as shovels, tongs or pokers.

WARNING

The bottom refractory can be cracked by excessive abuse such as tossing heavy logs onto the grate or gouging with fireplace tools. Exercise caution when adding wood to your fireplace.

Building a Fire (starting and maintaining a fire)

To start a fire, place several crumpled up balls of newspaper in the firebox. Place small dry pieces of kindling on top of the paper, criss-crossing the kindling so that there are air spaces in between. Keep the fuel far back enough so that air can get underneath. Open the air controls fully and light the newspaper. Once the newspaper and the kindling is well ignited, close the door. Once the kindling fire is well established, cord wood can be added (see *Primary Air Combustion Control* section for proper operation of the air controls).

The unit will burn best with 2-3 pieces of cord wood spaced 1 to 2 inches apart and allowing air to get under the fuel. Criss-crossing or arranging the fuel so that air can get underneath, will help the fire to get started easily. The unit should be operated with the air control fully open long enough to get the cord wood well ignited.

COMBUSTION CONTROLS

Primary Air and Air Boost Controls

There is no flue damper in the Brentwood LV fireplace. As is common with air tight stoves, the combustion air control sets the flow of air entering the firebox. This allows for a more precise control of the fire. The combustion air control is located below the door on the left side. The main source of air (primary air) entering the firebox can be diminished by moving the air combustion control from left to right. The primary air is fully opened when the air control is completely moved to the left. The air control device can also be used to add an extra boost of air especially during fire start up and reloading of the unit. Pulling the air combustion control will induce an air boost at the base of the fire allowing an easier fire start up. When the fire is well established, the control can be pushed in to shut down the air boost allowing for a longer burn time. The combustion air control should be in the closed position (primary air and air boost) when the fireplace is not in use. This will minimize air leakage up the chimney. The combustion air control should be opened before opening the door to minimize the possibility of back draft coming into the room.

Accelerated Combustion

The maximum heat output for the Brentwood LV fireplace is achieved by burning with the door closed and the combustion air opened and pulled out. By this method, the Brentwood LV fireplace can produce up to 55,000 BTU of

heat per hour. However, it will be necessary to reload with wood every one or two hours. This is the least efficient method of burning the Brentwood LV fireplace.

Use caution when firing with the combustion air control wide open. Only burn cord wood in this manner. Small dry pieces of softwood and construction scraps will burn very intensely using this method and may damage the firebox.

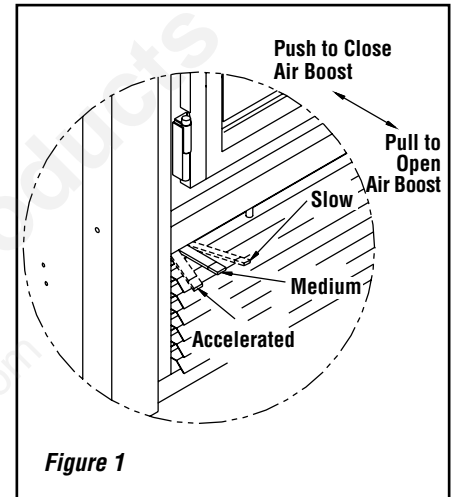

Figure 1

Medium Combustion

This is the recommended mode of operating the Brentwood™ LV fireplace and should be the one normally used since it will deposit the least amount of creosote on the glass and in the chimney. The combustion air control must be 3/4 closed (*Figure 1*) and pushed in to close the air boost. The precise setting will depend on many factors, including chimney length and the moisture content of the wood.

For instance, a long chimney will necessitate closing the damper more. To obtain the proper combustion, close the damper completely, then open it about 1/4" to 1/2". Three medium size pieces of wood should be burning on a bed of hot coals. The heat output will be approximately 30,000 BTU per hour and the loading time will be about every 3-4 hours. Softwoods may be burned using this method but the time will be substantially reduced.

Slow Combustion

When the air combustion control is completely closed, the fireplace is in a slow combustion phase. If the hearth is hot enough, slow combustion will not extinguish the fire, but there will be a noticeable change in the flame pattern. The flames will be slow and may appear dirty if the wood is too wet (moisture content of 20% and more). Do not allow the wood to burn without flame, since this will produce excessive creosote in the unit.

NOTE: DIAGRAMS & ILLUSTRATIONS ARE NOT TO SCALE.

Creosote may accumulate on the glass door. This method of burning should be used only after operating the Brentwood LV fireplace with the air control opened (**Figure 1**) to produce a hot fire for about an hour or at medium pace for at least three (3) hours. Slow combustion can be used at night in order to reduce the heat output and to prolong the burn. The loading time will be between 6-8 hours.

REFUELING FOR BEST PERFORMANCE

The Brentwood LV fireplace will operate best if attention is given to operating the unit with the damper fully opened (**figure 1**) after refueling in order to bring the firebox and the chimney system up to their optimum operating temperature. Combustion efficiency is relative to firebox temperature. A temperature of 932° F (500° C) and up, with a visible flame, in the upper part of the firebox indicates a maximum efficiency. To obtain this temperature, the fireplace must be operated with the primary air and air boost controls fully opened during 10 to 20 minutes after reloading, depending on the heat and on the moisture content of the wood.

Once you have reached the desired temperature, the air boost can be closed and the primary air set to a medium setting. You know you have reached the desired temperature when, closing the primary air control, you can see a flame at the top of the firebox. The benefit of this technique will be cleaner glass, less creosoting, greater efficiency and the most pleasing fire for your enjoyment. If your fireplace is equipped with a forced air system, make sure the central blower is turned off during reloading to avoid smoking problems.

SMOKING – CAUSES AND TROUBLESHOOTING

To reduce the likelihood of smoking when opening the door, set the combustion air controls to the left before opening the door. Your fireplace has been designed and tested to provide smoke free operation. Occasionally, there may be a small amount of smoking upon lighting the fire, until the chimney heats up but this should not continue. If the fireplace continues to smoke it is probably for one of the following reasons:

A. Negative pressure in the house -

As the fire burns, air goes up the chimney. This air must be replaced through leakage into the house or through the outside air duct. When operating the Brentwood LV fireplace, open a nearby window temporarily to check if there is adequate replacement air supply.

B. Blowers operating (e.g.: range hood) -

These blowers draw air out of the house and may actually cause a negative pressure in the house. Turn off all blowers and open a nearby window to determine if this is the cause of the problem.

C. Wetwood - Wet or tarred wood will smoulder and smoke instead of burning properly. Your dealer can help you determine if you have properly seasoned wood for burning.

D. Dirty or blocked chimney - Check to make sure the chimney is clear and clean. If dirty call a certified chimney sweep or use a properly sized chimney brush to clean.

E. Chimney not long enough - The minimum chimney height is twelve (12) feet (3.7 m) not including the fireplace height. The chimney must extend at least three (3) feet (915 mm) above its point of contact with the roof and at least two (2) feet (610 mm) higher than any roof or wall within ten (10) feet (3 m) of it. When installed with offsets, the minimum chimney height is fifteen (15) feet. Additional height will increase draft and will decrease the tendency to smoke.

F. Poor chimney draft - With no fire, there should be sufficient draft to exhaust cigarette smoke introduced under the baffle. Chimneys installed against an outside wall without protection may generate back draft problems which will cause start-up problems. To prevent this, open a nearby window, roll up a piece of paper and light it. Then, hold it in the upper part of the firebox to warm up the chimney. Wait until the draft is sufficient, then start the fire.

G. Blower for forced air kit operating - Make sure that the blower is in the "off" position when you open the fireplace door for reloading.

IMPORTANT CAUTIONS

A. Do not block the hot air vents to the fireplace as this will cause the fireplace to overheat.

B. Never use gasoline, gasoline-type lantern fuel, kerosene, charcoal lighter fluid, or similar liquids to start or 'freshen up' a fire in this fireplace. Keep all such liquids well away from the fireplace while it is in use.

C. Do not burn coal. The sulphur in coal will corrode the firebox and chimney.

D. Do not burn driftwood which has been in the ocean or salt water. The salt will corrode the firebox and chimney.

E. Do not burn wood in the area in front of the grate.

F. Do not abuse the unit by burning paper, or cardboard or construction material such as pressed wood, plywood or lumber. Wood protectors, metallic paper, coal, plastic, waste, sulphur and/or oil will damage the fireplace.

G. Do not allow the wood to smoulder or burn without flame, since this will produce excessive creosote in the unit as well as increased particulate emissions.

Smoke Detectors Recommended

Since there are always several potential sources of fire in any home, we recommend installing smoke detectors. If possible, install the smoke detector in a hallway adjacent to the room (to reduce the possibility of occasional false activation from the heat produced by these

appliances). If your local code requires a smoke detector be installed within the same room, you must follow the requirements of your local code. Check with your local building department for requirements in your area.

Carbon Monoxide Monitor Recommended

Carbon Monoxide Poisoning: Early signs of carbon monoxide poisoning are similar to the flu with headaches, dizziness and/or nausea. If you have these signs, obtain fresh air immediately. Some people are more affected by carbon monoxide than others, including pregnant women, people with heart or lung disease or anemia, those under the influence of alcohol, and those at high altitudes.

It is against federal regulations to operate wood heaters in a manner inconsistent with operating instructions in the manual.

MAINTAINING YOUR BRENTWOOD™ LV FIREPLACE

Have your product inspected at least once a year by a qualified service technician to ensure gaskets, air tubes, baffles, and venting are in good repair to ensure proper performance. Have degraded items replaced by a qualified service technician.

This wood heater needs periodic inspection and repair for proper operation. Consult the owner's manual for further information. It is against federal regulations to operate this wood heater in a manner inconsistent with the operating in this manual.

Creosote - Formation and Need for Removal

When wood is burned slowly, it produces tar and other organic vapors, which combine with expelled moisture to form creosote. The creosote vapors condense in the relatively cool chimney flue of a slow-burning fire.

As a result, creosote residue accumulates on the flue lining. When ignited this creosote makes an extremely hot fire.

The chimney shall be inspected at least twice a year during the heating season to determine when a creosote buildup has occurred.

When creosote has accumulated it shall be removed to reduce the risk of a chimney fire.

When the creosote accumulation is large, a creosote fire in the chimney can damage the chimney and overheat the surrounding wood framing. Creosote formation in a chimney can be minimized by making sure there is always visible flame burning, avoid smouldering fires and by proper refuelling techniques.

Chimney Maintenance

Regular chimney inspection and maintenance combined with proper operation will prevent chimney fires. Keep your chimney clean. Do not allow more than 1/16" (1.6 mm) creosote build up in your chimney. The amount of creosote will depend on variables such as frequency of use and type of fire. We recommend that you:

- A. Initially inspect the chimney system weekly. From this, you will learn how often it will be necessary to clean your chimney.
- B. Have your chimney cleaned by a qualified chimney sweep. If you wish to clean it yourself, we recommend using a stiff plastic or non-metallic brush. If a metal brush is used, its size should be slightly smaller than the flue to avoid damaging the chimney. Do not use a brush that will scratch the stainless steel interior of the chimney.
- C. Do not expect chemical cleaners to keep your chimney clean. The rain cap can be removed for inspection and/or cleaning of the chimney.

Top Baffle Removal Prior to Cleaning The Chimney

Before starting to clean your chimney, we recommend that you remove the top baffle to avoid creosote dust collection at the top of the baffle. Follow these steps to set the top baffle out of the way:

1. Remove the side refractory holder. They are located at the top of the refractory.
2. Lift the front baffle.
3. Slide the back baffle under the front baffle. You now have access to the chimney.

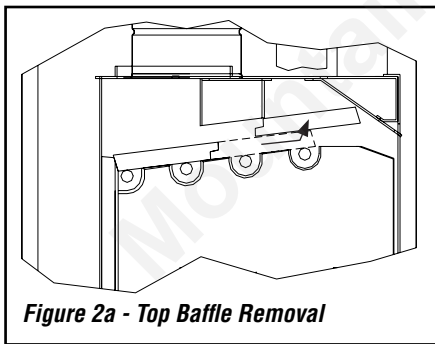

Figure 2a - Top Baffle Removal

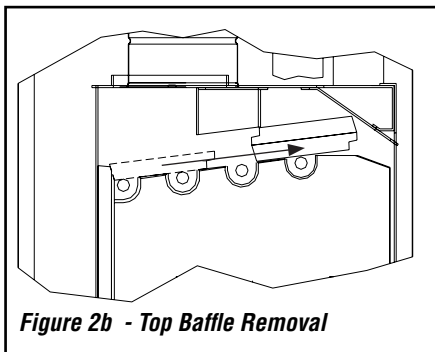

Figure 2b - Top Baffle Removal

Dealing With a Chimney Fire

Regular chimney maintenance and inspection can prevent chimney fires. If you have a chimney fire, follow these steps:

1. Close the fireplace door and the combustion air controls.
2. Alert your family of the possible danger.
3. If you require assistance, alert your fire department.
4. If possible, use a dry chemical fire extinguisher, baking soda or sand to control the fire. Do not use water as it may cause a dangerous steam explosion.
5. Check outside to ensure that sparks and hot embers coming out of the chimney are not igniting the roof.
6. Do not use the fireplace again until your chimney and fireplace have been inspected by a qualified chimney sweep or a Fire Department Inspector.

Achieving Clean Burns

Check the exhaust in about 15 to 20 minutes (see below). Large amounts of smoke indicate an improper burn setting (either too high or too low). Adjust and recheck in 5 to 10 minutes.

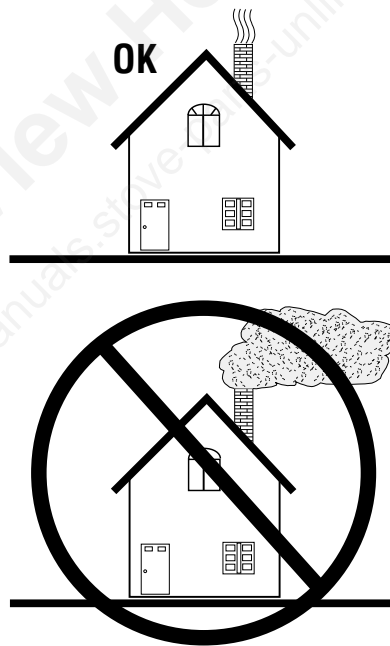

What does "Well-Seasoned" mean?

When a tree is cut down, the wood is green, full of sap and moisture. This moisture content can exceed 80%, which must be reduced to less than 20%. Wood properly seasoned is then capable of generating the heat the stove was designed to provide.

Green wood does not burn easily. Attempting to burn green wood often results in a lot of smoke and very little fire. Time is the most important factor in seasoning wood. Ideally the moisture content should be reduced to 11-20%.

NOTE: The use of a firewood moisture meter is recommended to ensure the firewood contains less than 20% moisture.

Seasoning Guide

Softwoods - 6 months to 18 months
Hardwoods - 12 months to 24 months

Logs that are 5" diameter across or larger should be split in half, three pieces if over 8 inches, and four pieces when over a foot across. If a tree has been dead for 2 - 4 years it still needs to be cut, split, and seasoned for 6 to 24 months depending on the wood.

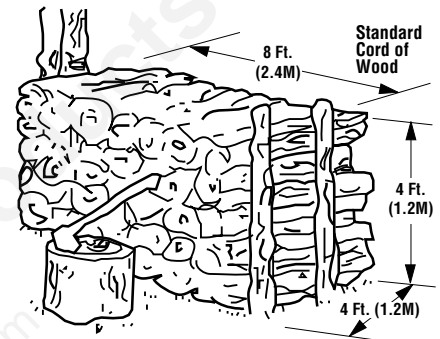

Prohibited Fuels

This heater is designed to burn natural wood only. Higher efficiencies and lower emissions generally result when burning air dried seasoned hardwoods, as compared to softwoods or to green or freshly cut hardwoods. **DO NOT BURN:**

- Garbage;
- Lawn clippings or yard waste;
- Materials containing rubber, including tires;
- Materials containing plastic;
- Waste petroleum products, paints or paint thinners, or asphalt products;
- Materials containing asbestos;
- Construction or demolition debris;
- Railroad ties or pressure-treated wood;
- Manure or animal remains;
- Salt water driftwood or other previously salt water saturated materials;
- Unseasoned wood;
- Christmas tree branches;
- Paper products, colored paper, cardboard, plywood, or particleboard;
- gasoline;
- naphtha;
- engine oil;
- flammable liquids;
- solvents;
- grease; or
- coal

The prohibition against burning these materials does not prohibit the use of fire starters made from paper, cardboard, saw dust, wax and similar substances for the purpose of starting a fire in an affected wood heater.

NOTE: DIAGRAMS & ILLUSTRATIONS ARE NOT TO SCALE.

Burning these materials may result in release of toxic fumes or render the heater ineffective and cause smoke. Intense firing with these materials may overheat the fireplace, causing damage to the unit, a fire or even possibly igniting a chimney fire if the chimney is creosoted. Burning unapproved fuel, resulting in excessive pollutants being emitted, may be prohibited and subject to a fine or other penalty by the authority having jurisdiction in your area.

Finish Door Casing Care

Use a glass cleaner and a soft cloth to polish the casing. Do not use abrasives such as steel wool, steel pads or an abrasive polish for they may scratch the casing's finish.

DISPOSING OF ASHES

! WARNING

Disposal of Ashes: Ashes should be placed in a steel container with a tight fitting lid and moved outdoors immediately. The closed container of ashes should be placed on a non-combustible floor or on the ground well away from all combustible materials, pending final disposal. If the ashes are disposed of by burial in soil or otherwise locally dispersed, they should be retained in the closed container until all cinders have thoroughly cooled.

Whenever ashes get 3 to 4 inches deep in your firebox, and when the fire has burned down and cooled, remove excess ashes. Leave an ash bed approximately 1 inch deep on the firebox bottom to help maintain a hot charcoal bed.

Remove ashes only when the fire is out and the ashes are cold (24 to 48 hours after the fire is out). Do not leave the ashes in the house as they give off carbon monoxide and other toxic gases.

REFRACTORY REPLACEMENT

The intense heat of the fire will normally cause hairline cracks in the refractory. These cracks can be minimized by proper curing as described in "First Fires". They will not normally diminish the effectiveness of the refractory. If large cracks develop, then the refractory should be replaced. To replace the refractory bricks, follow these steps:

1. Remove the front refractories
2. Remove the bottom refractory
3. Remove the left side refractory
4. Remove the right side refractory
5. Remove the back refractory
6. Remove the front ceramic baffle
7. Remove the rear ceramic baffle

To install the new refractories, follow the above steps in reverse.

DOOR INSTALLATION

Your fireplace door has been factory installed and adjusted.

To remove the door simply unscrew the top hinge from the door then lift the door (without touching the trim over the door) to disengage the male part of the bottom hinge from the female part.

The door adjustment has been set at the factory. If the fit is still not perfect, you can adjust the door using the hinge screws.

DOOR ADJUSTMENT

The door may need to be adjusted to be completely airtight. The gaskets' air-tightness can be adjusted using the adjustment screw located on the right side of the fireplace facade (An Allen key #1/8 – not supplied - will be necessary for this adjustment).

Checking Door Seal - A one-inch strip of paper may be used to perform a test of the integrity of the door seal. Close the door on the paper in at least eight points. It is normal to feel only a slight amount of friction. The door gasket does not need to be "tight" in all areas, since a small amount of leakage is not hazardous or detrimental to the performance of your fireplace.

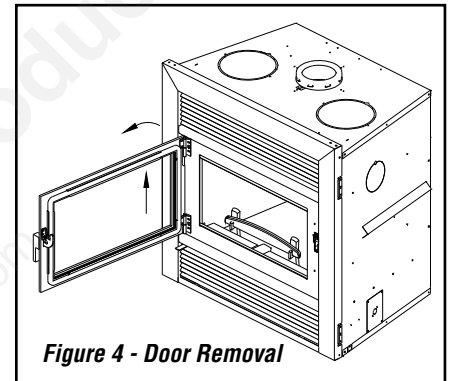

Figure 4 - Door Removal

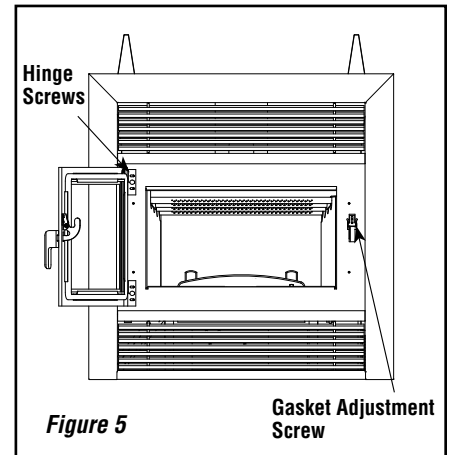

Figure 5

Gasket Adjustment Screw

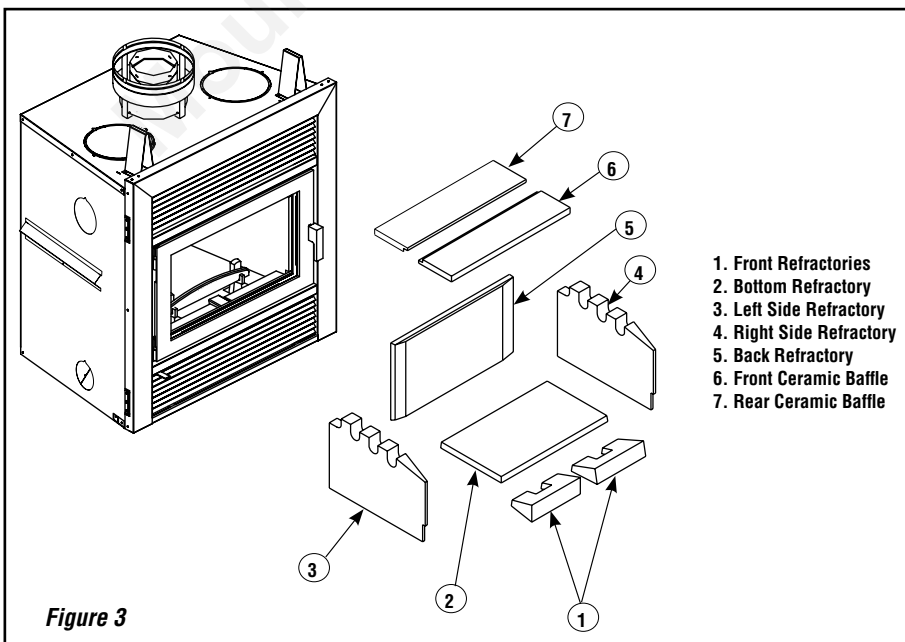

Figure 3

1. Front Refractories
2. Bottom Refractory
3. Left Side Refractory
4. Right Side Refractory
5. Back Refractory
6. Front Ceramic Baffle
7. Rear Ceramic Baffle

! WARNING

- Use only a IHP glass doors, specifically designed for the Brentwood™ LV fireplace.
- The fireplace cannot be operated without door or firescreen. Consult your dealer to select the correct replacement door or firescreen.
- Important! To assure proper alignment of glass doors: Install this fireplace in a square and plumb condition, using shims as necessary at sides and/or bottom.

NOTE: DIAGRAMS & ILLUSTRATIONS ARE NOT TO SCALE.

GLASS CARE

Glass Replacement

The glass used for the Brentwood™ LV fireplace is a high temperature ceramic glass (1,400° F / 760° C). If the glass breaks, it must be replaced with an identical ceramic glass. Tempered glass or ordinary glass will not withstand the high temperatures of the Brentwood LV fireplace. Replacement glass should be purchased from a IHP dealer (see “Replacement Parts”, **Page 25**). **DO NOT OPERATE THE UNIT WITH CRACKED OR BROKEN GLASS.**

Glass Cleaning

The Brentwood LV fireplace is designed to keep the glass clean under normal operating conditions. If the Brentwood LV fireplace is operated continuously with the combustion air controls closed, the glass will tend to get dirty unless the fuel, firebox and glass are maintained at hot temperatures (see “Refueling For Best Performance”). To clean the glass, there are a number of specially designed cleaners. Your IHP dealer can recommend a suitable cleaner which is available in your area. Regular household glass cleaners will not clean creosote. **Do not use abrasives such as steel pads, steel wool or oven cleaner as they will scratch the glass.**

DO NOT USE CHEMICAL GLASS CLEANERS ON PAINTED SURFACES AS IT MAY CAUSE THE PAINT TO PEEL.

CAUTION: DO NOT ALLOW WINDOW CLEANER TO GET IN CONTACT WITH DOOR OR PAINT ON FACADE OR DOOR. ONCE CLOSED, CONTACT OF GLASS CLEANER WITH THE FIREPLACE FACADE CAN PROVOKE PAINT PEELING OFF.

Gasket Replacement

Remove the door from the unit (see **Page 7**) and lay it on a clean unabrasive surface. To replace the gasket, first remove all of the old gasket and gasket cement. Make sure that the surface is totally clean before applying new cement (a high temperature silicone caulking rated at 500° F [260° C] is suitable) or adhesion problems may result. Apply gasket cement to the gasket channel and install the new gasket. This replacement part is available from your IHP dealer in the following dimensions:

Gasket	Length*	Dimensions	Part No.
Around Glass	74 (1880)	3/16" x 1" (4.8 x 25.4)	PR-SR1685J
On Door Frame	77-3/4 (1975)	3/4 dia. (19)	PR-SR18230

Table 1 * Inches (millimeters)

FIREPLACE INSTALLATION

Locating The Brentwood LV Fireplace

The best location to install your fireplace is determined by considering the location of windows, doors, and the traffic flow in the room where the fireplace is located, allowing space in front of the unit for the hearth extension and the mantel, and taking into consideration the location of the hot air ducts (optional), outside air kit and chimney.

If possible, you should choose a location where the chimney will pass through the house without cutting floor or roof joists (see fireplace dimensions **Page 11**).

Usually, no additional floor support is needed for the fireplace. The adequacy of the floor can be checked by first estimating the weight of the fireplace system. Weights are given in the appendix. Note the floor construction and consult your local building code to determine if additional support is needed.

The Brentwood LV fireplace may be installed directly on the floor or on a raised base (for proper guidelines, refer to “Hearth Extension Requirements”) and a minimum of 6’8” (2 m) measured from the base of the appliance to the ceiling is required.

When selecting the location, the chimney outlet position and the direction of the wind are important factors affecting the chimney performance. To allow a maximum draft and to reduce wind turbulence, the chimney must:

- Penetrate the highest part of the roof.
- Be installed as far as possible of roof offsets, trees or any other obstructions that may cause wind turbulence and back drafts in the chimney.
- The least amount of offsets (elbows) possible. **NOTE: A maximum of 2 offsets is allowed.**

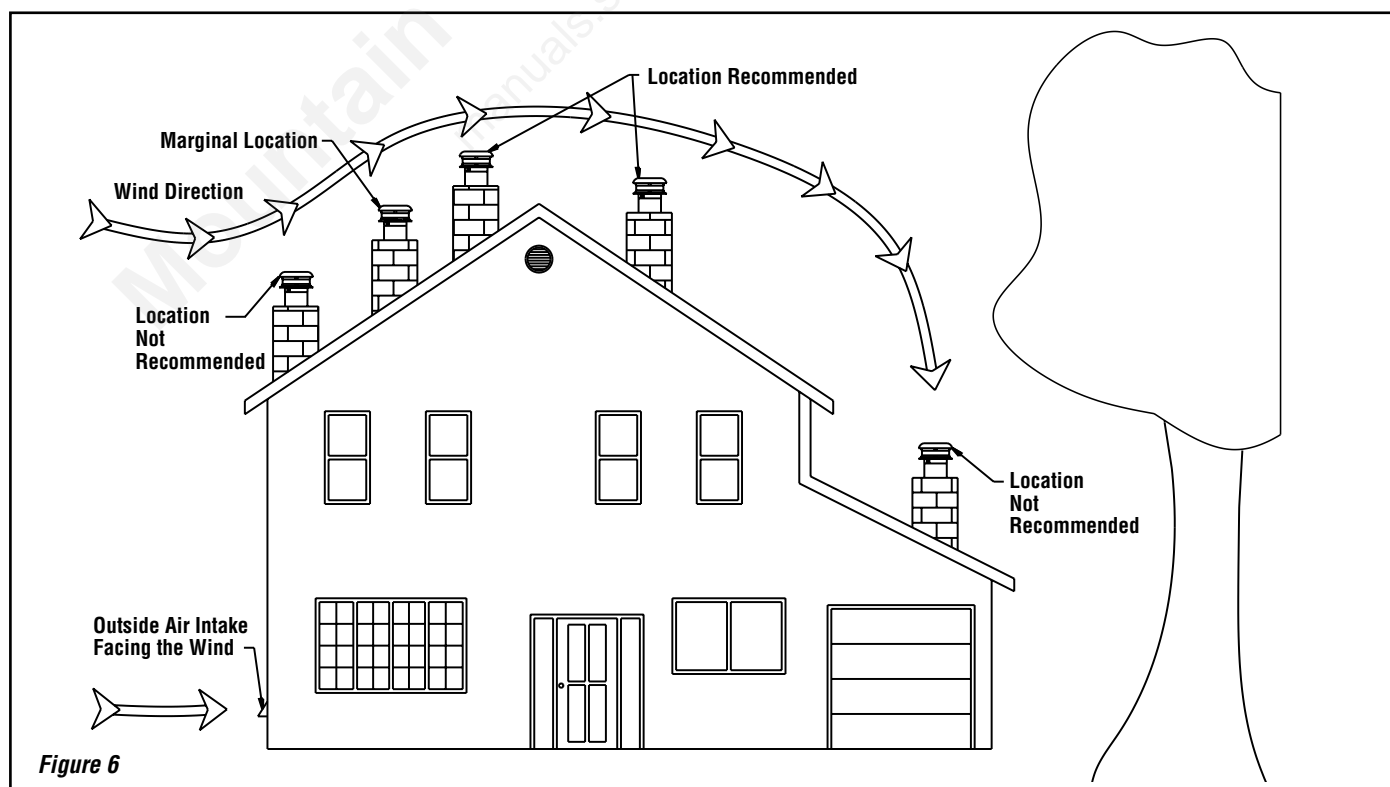

Figure 6

NOTE: DIAGRAMS & ILLUSTRATIONS ARE NOT TO SCALE.

INSTALLING THE FINISHING KITS

The Brentwood™ LV requires the installation of a finishing kit. Two options are available:

1. Louver kit (part number: LOUVRECF)
OR
2. Clean face kit (part number: CAPPINGCF)

Installing The Louver Kit

The louver kit includes two identical louver assemblies. The louvers must be oriented so the angular parts of the grills are towards the front and the bottom and the cotter pins are at the bottom.

Insert the top of the louver rods in the top trims holes. Then insert the bottom of the rods in the holes at the bottom of the opening. The cotter pins will rest on the bottom trim in order to vertically locate the louvers.

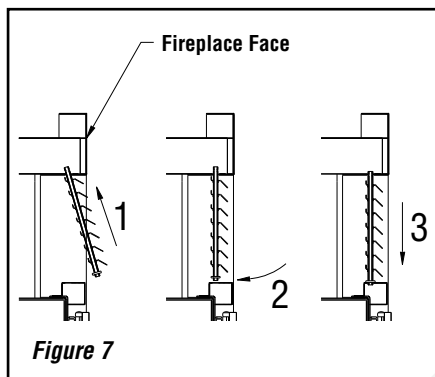

Installing The Clean Face Kit

The clean face kit includes four parts. Two trims, left and right, are used to cover the edge of the finishing material on the sides, and two obstruction plates to cover the top and bottom openings allowing to install the finishing material closer to the door.

WARNING: The bottom obstruction plate is designed to leave an opening area for the convection air to circulate and cool your fireplace. NEVER BLOCK THIS AIR SPACE TO AVOID OVERHEATING THE FIREPLACE AND POTENTIALLY CAUSE A FIRE IN YOUR HOME.

The gravity kit MUST BE used with the clean face kit to allow hot air flow that would normally come out of the top louver. ANY OTHER INSTALLATION MAY RESULT IN THE FIREPLACE OVERHEATING AND POTENTIALLY CAUSE A FIRE.

See *Gravity Kit* section on **Page 14** to install the gravity vent kit.

Installation Steps:

1. Install the side finishing trim, making sure to differentiate the left from the right. The shortest end bend should be towards the bottom.
2. Install the right side trim. The full length flat part must rest against the right side face frame, the center bend must be oriented towards the outside of the unit and the bends towards the inside. The end bend on top must be pushed between the crossing

trim and the right side frame. This can be difficult because these are close together to allow a good look when using the louver kit. The part will be fixed in place when installing the other parts.

3. Repeat with the left trim.
4. Install the top obstruction plate in the top opening, oriented so the insulation faces the inside and the 1/2 inch bend is towards the outside and the bottom. The part is pressure installed to keep from using screws that could interfere with your finishing material. Place the bottom bend on the lower trim and push on it to insert the top bend. Push on the part so the ends lie well on the fireplace face.
5. Install the bottom part the same way. Make sure to push the part to the bottom to leave the required air space.
6. (Optional) You can use rivets or sheet metal screws on all four (4) corners to secure the installation.

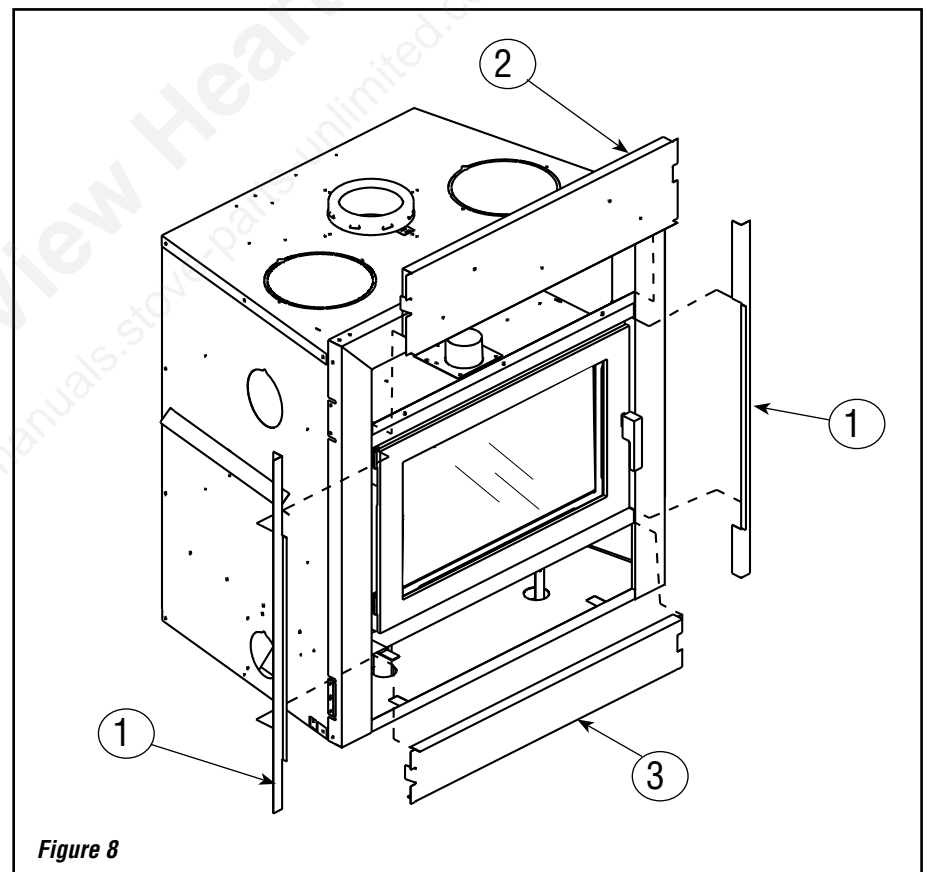

Figure 8

NOTE: DIAGRAMS & ILLUSTRATIONS ARE NOT TO SCALE.

Framing, Facing And Mantel

The construction of the framing, facing, and mantel must be in accordance with the standards and the following illustrations (**Figures 9, 10 and 11**):

- A. Frame the fireplace using 2" x 3" or heavier lumber.
- B. **WARNING: Combustible materials cannot be used in the space directly above the fireplace, except for the studs above the facade that support the facing and mantel. This area must remain empty for a height of 6'8" (2,032 mm) measured from the base of the appliance.**
- C. Frame the fireplace with vertical studs at the sides of the fireplace running from floor to ceiling (see **Figure 11**). If combustible facing is to be used, position the studs back, from the front edge of the fireplace (a space that is the thickness of the facing material, so that the facing can be installed flush with the fireplace facing). Frame headers between the vertical studs only as follows:
 - Place 2" x 3" or 2" x 4" headers, only along the upper part of the front, side and back faces (some codes may require a 2" x 6" on an outside bearing wall). Do not put wood or any combustible material within the area above the fireplace except on the front facing.
 - Place headers only as required to support the facing and mantel.
- D. **WARNING: The fireplace must not be in contact with any insulation or loose filling material. Cover the insulation with Drywall panels around the fireplace.**

Hearth Extension Requirements

The Brentwood LV fireplace may be installed directly on a combustible floor. The supplied safety metal strip must be positioned as follows: One half under the front of the fireplace and the other half must extend on the floor over which the hearth extension will be built (see **Figure 9**).

* The safety metal strip must cover the entire width of the fireplace

The combustible floor in front of the fireplace must be covered with a non-combustible material (tile, marble, stone, etc). See **Figures 9 and 10**.

COLD CLIMATE INSTALLATIONS

Climates where temperatures will fall below 32° F (0° C).

The heating performance of the appliance will vary depending upon the level of insulation, house design, how the appliance is operated, etc.

If this fireplace is being installed in a cold climate, it is especially important to seal all cracks around the fireplace and wherever cold air could enter the room with noncombustible material.

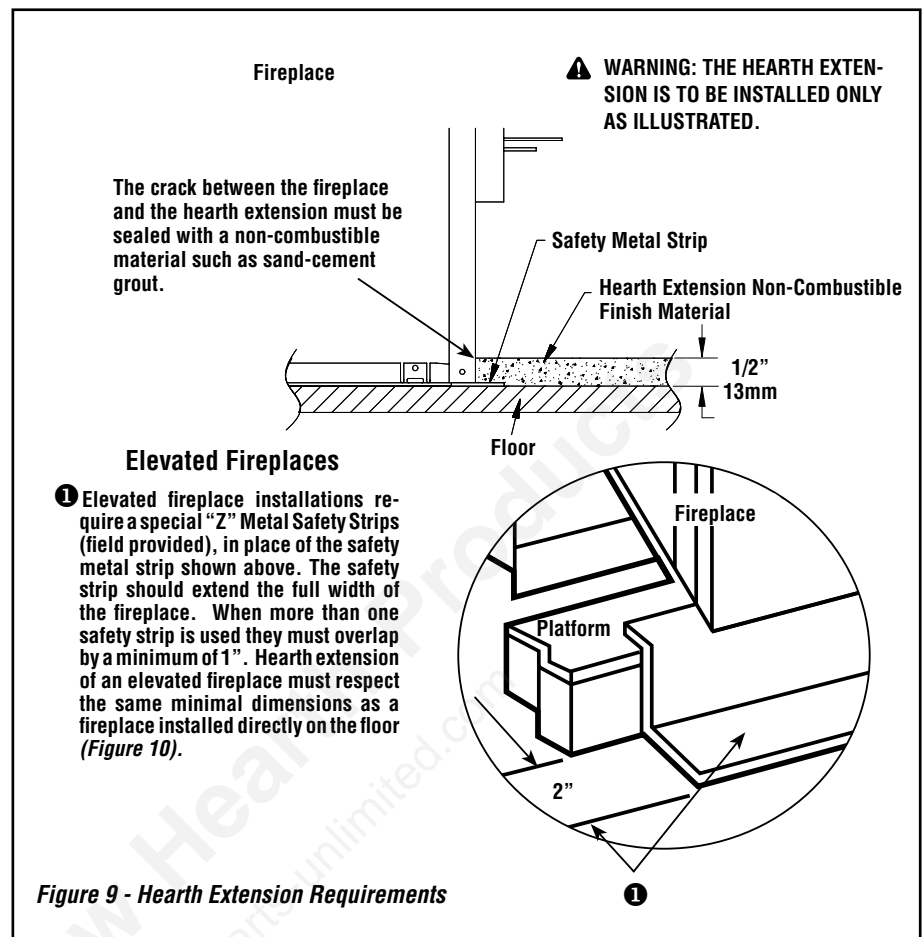

Figure 9 - Hearth Extension Requirements

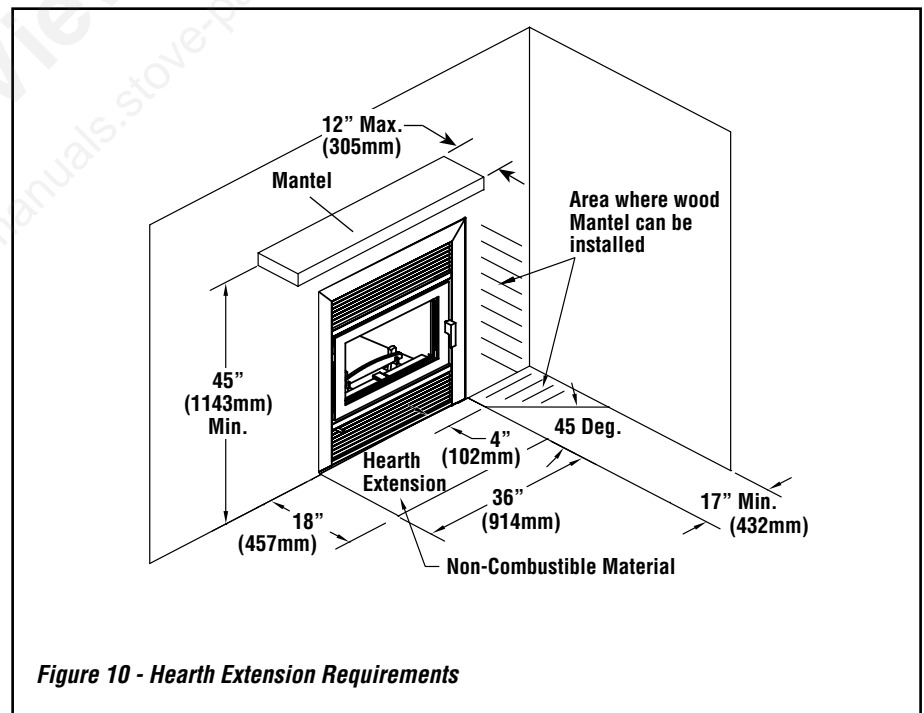
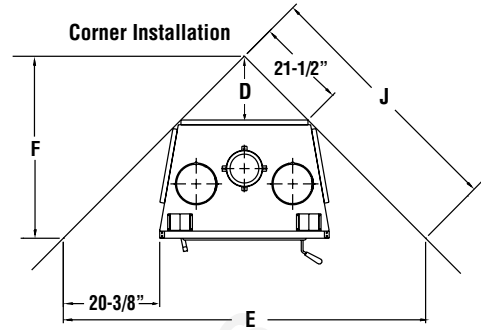
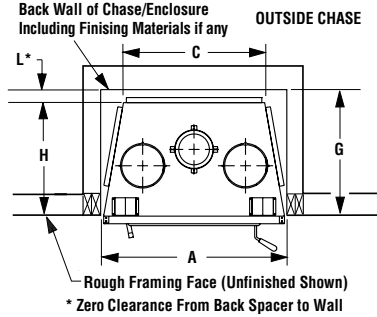
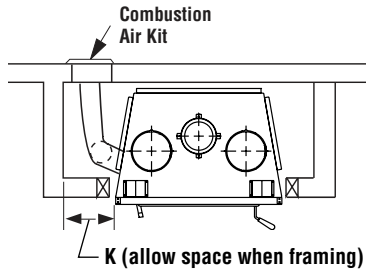

Figure 10 - Hearth Extension Requirements

Also, the outside air inlet duct should be wrapped with noncombustible insulation to minimize the formation of condensation. Do not place insulation materials directly against the chimney sections. We recommend that you use the insulated wall radiation shield since it will maintain the home's thermal barrier. AC chimney is NOT recommended in very cold climates (in areas with temperatures below 32°F (0°C)).

NOTE: DIAGRAMS & ILLUSTRATIONS ARE NOT TO SCALE.



FRAMING DIMENSIONS		
A	36-1/4"	921 mm
B	40-3/4"	1035 mm
C	28-1/8"	714 mm
D	13-1/4"	337 mm
E	76-3/4"	1950 mm
F	38-3/8"	975 mm
G	*25"	635 mm
H	24-1/2"	622 mm
J	54-1/4"	1378 mm
K	8"	203 mm
L	1"	25 mm

Combustible materials can NOT be used in the space directly above the fireplace. Do not fill the space above the fireplace with any material (Except the wood framing)

* Total depth is 25-1/2 inches including the back spacer minus 1/2 inch for drywall to be flush with the facing.

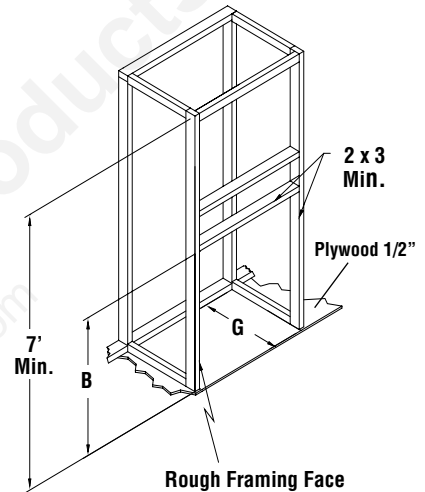
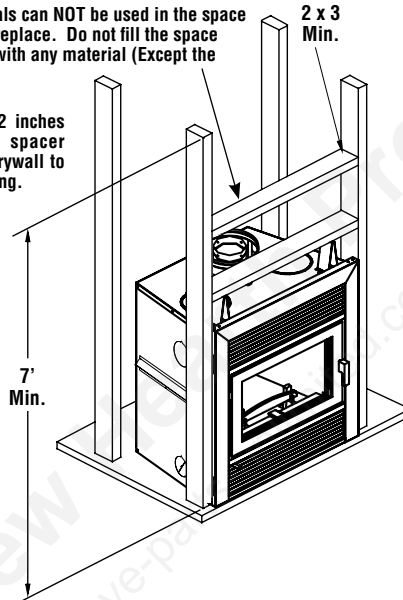

Dimensions with clean face obstruction plate kit installed

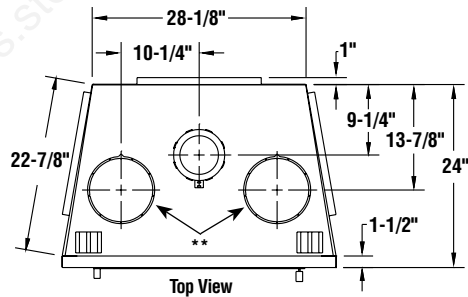
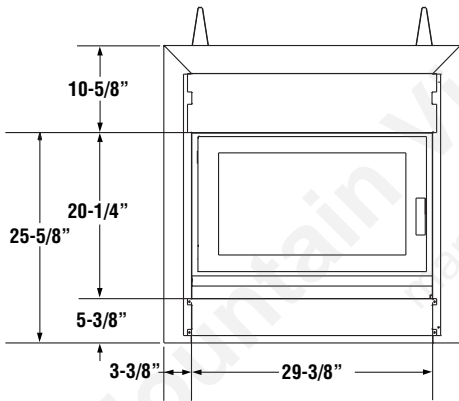

**Gravity Vent Outlets

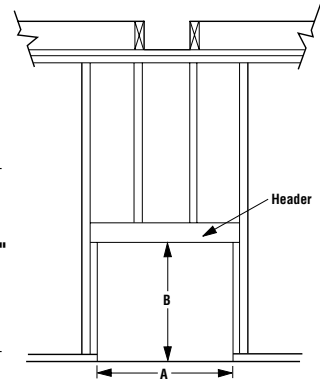

NOTES

Diagrams, illustrations and photographs are not to scale - consult installation instructions. Product designs, materials, dimensions, specifications, colors and prices are subject to change or discontinuance without notice.

All framing dimensions calculated for 1/2" dry wall at the fireplace face. If sheathing the chase or finishing with other thickness materials, calculations will need to be made.

* The fireplace must not be in contact with any insulation or loose filling material. Cover the insulation with Drywall panels around the fireplace.

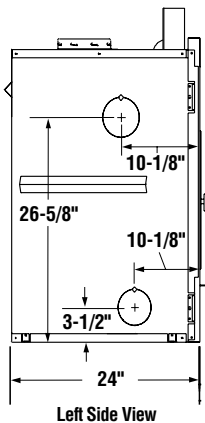

Left Side View

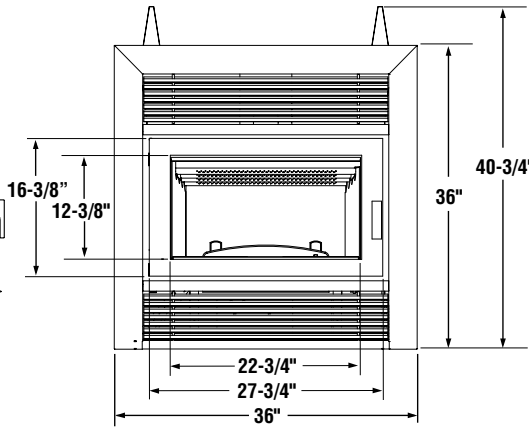

Front View

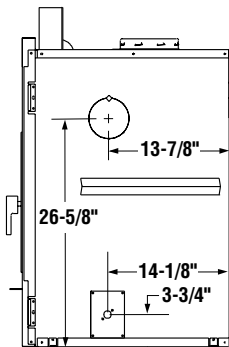

Right Side View

Figure 11 - Fireplace and Framing Dimensions

NOTE: DIAGRAMS & ILLUSTRATIONS ARE NOT TO SCALE.

Insulated Chase Construction

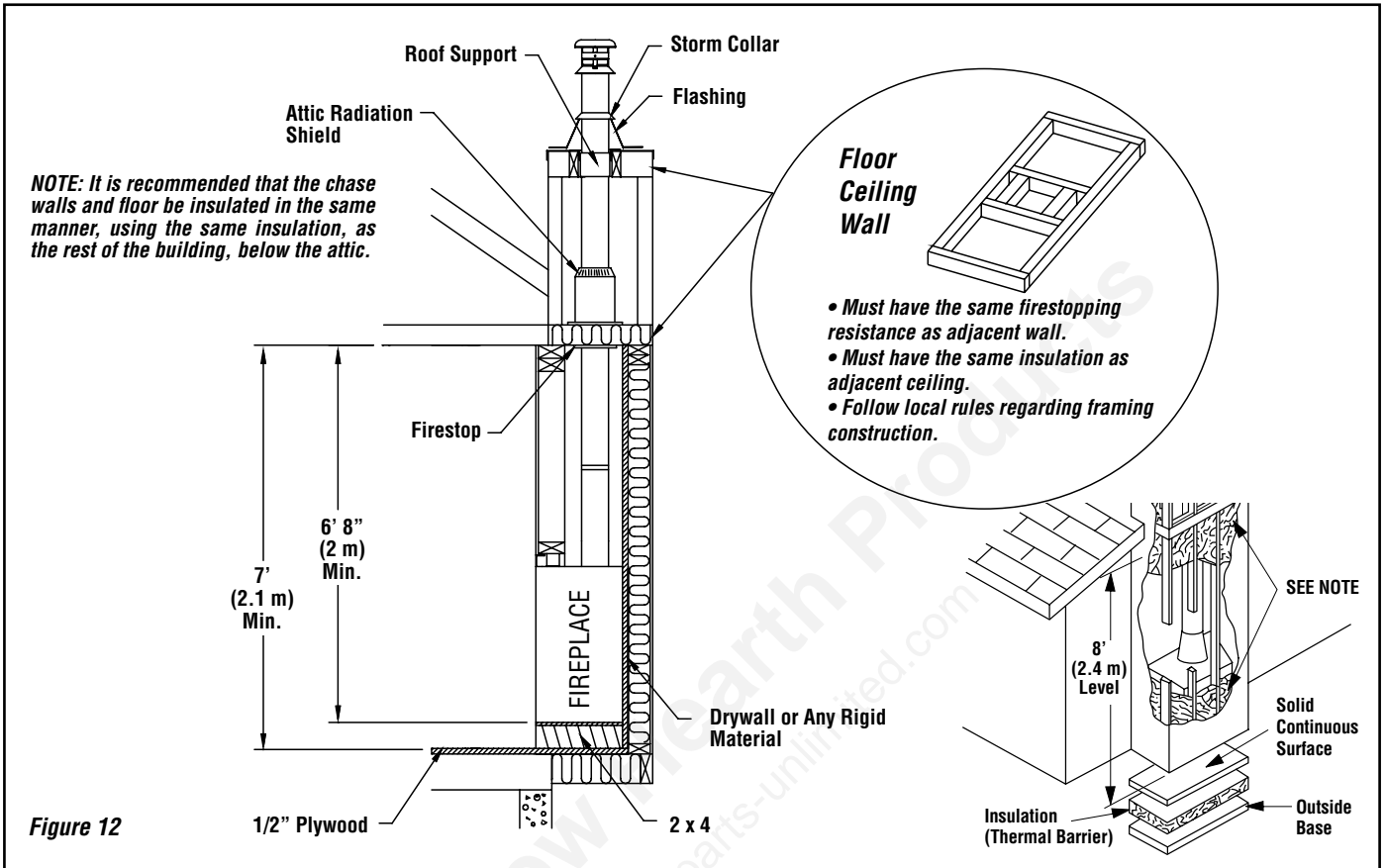

Nailing Flanges

Four nailing flanges are provided to secure the fireplace to the floor (see **Figure 13**). Bend the nailing flanges down so that each flange is flush with the floor, then using nails or screws, secure the fireplace to the floor (2 places each side). The heads of the screws or nails must be large enough to completely cover the holes in the nailing flanges.

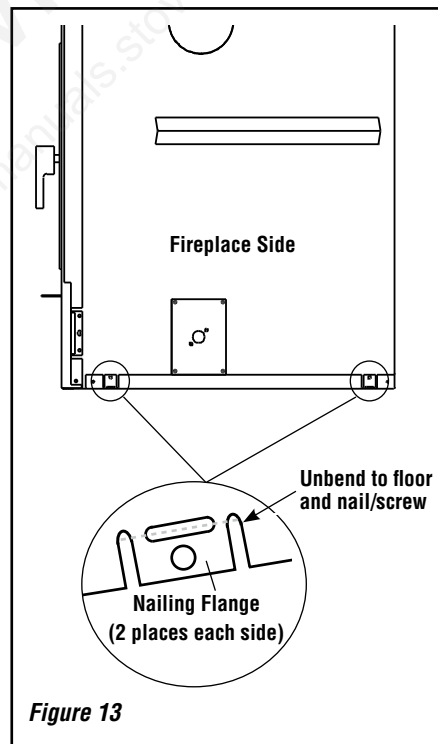

NOTE: DIAGRAMS & ILLUSTRATIONS ARE NOT TO SCALE.

Facing

The facing installation method depends on your finishing kit choice.

- Facing with the louver kit** - The 2x3 framing must offset to the back by a distance equivalent to the thickness of your facing material so the surface of the facing be aligned with the fireplace face. Combustible materials must be aligned with the fireplace face and can not overlay on the fireplace front (black steel face of the fireplace) (see **Figures 14 and 15**).

*NOTE: Non-combustible materials like brick, stone or ceramic tiles may be overlaid on the fireplace front (see **Figure 16**).*

- Facing with the clean face kit - Must be used in conjunction with a gravity vent kit.** The 2x3 framing must offset to the back by a distance equivalent to the thickness of the drywall.

Combustible materials must be installed to be aligned with the fireplace front and can not overlay on the fireplace front (black steel face of the fireplace) (see **Figures 16 and 17**). Non-combustible materials such as brick, stone or ceramic tile can project in front of and onto the fireplace facing up to the tiling flange on the clean face kit (**Figure 19**).

Mantel

The mantel must be installed at least 45" (1143mm) above the base of the fireplace (**Figure 14**).

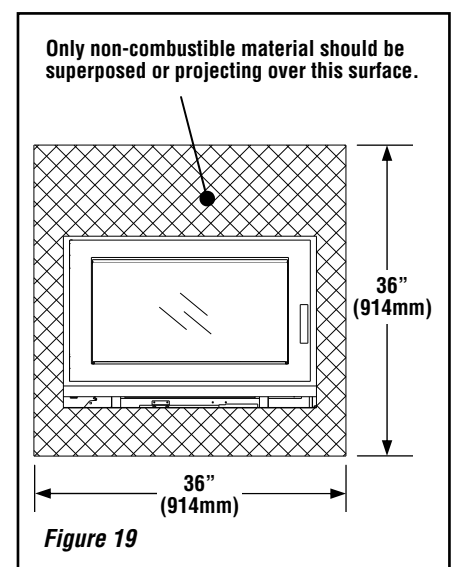
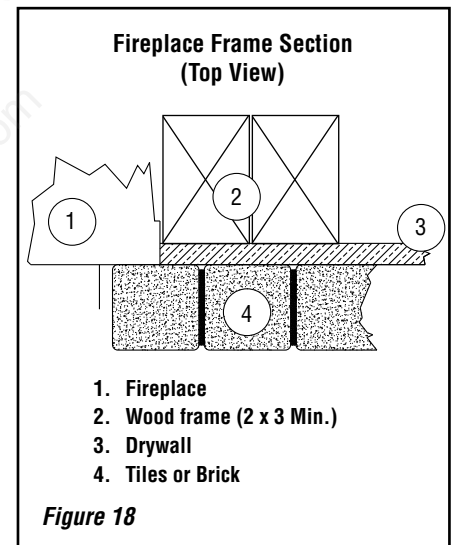
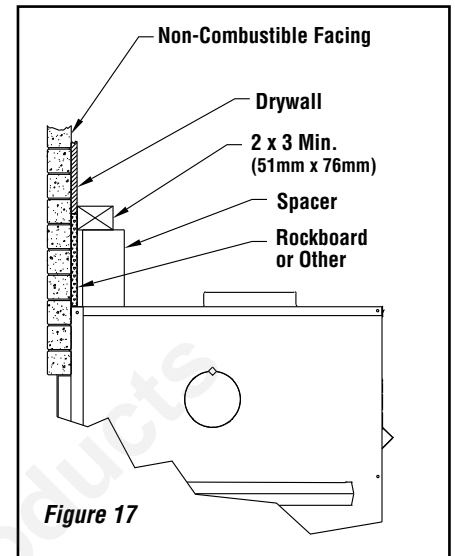
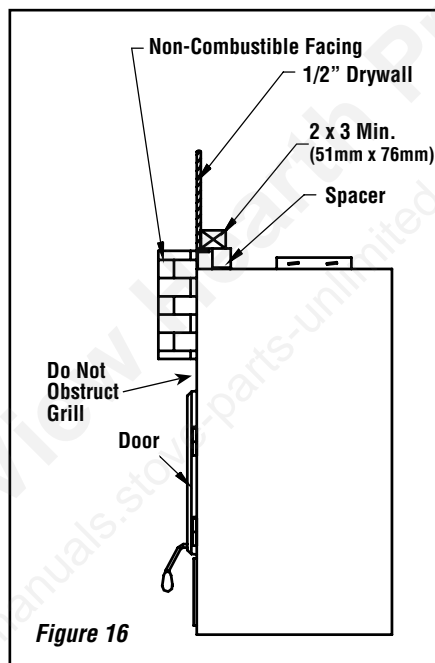
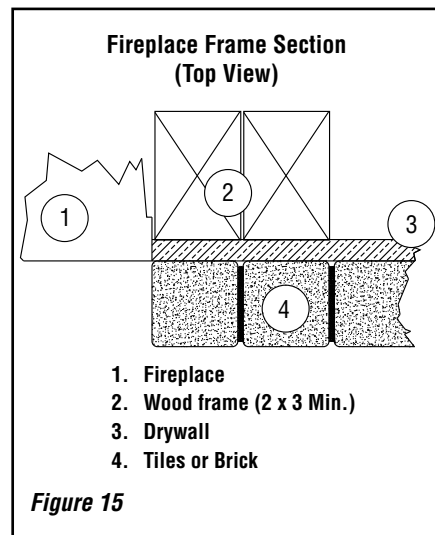
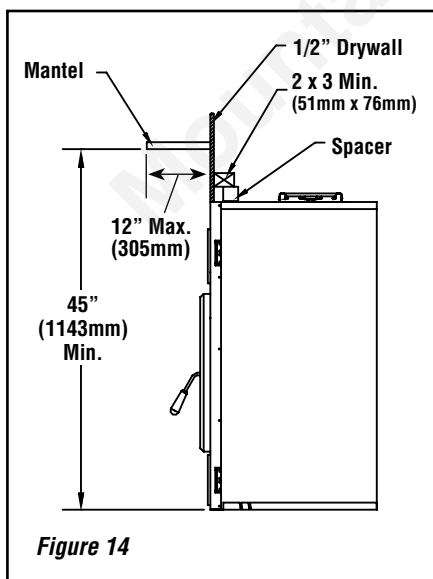

HOT AIR DUCTING INSTALLATION

Different hot air ducting systems can be installed with the Brentwood™ LV fireplace:

- Gravity kit
- Forced air kit

Gravity Kit

The gravity kit is designed for double hot air outlets and includes: (See **Figures 20 and 21**)

- 2 telescopic lengths 8" I.D.
- 2 90° elbows 8" I.D.
- 2 hot air outlet kits (grill and frames)
- 2 adaptors

See *Gravity Kit Accessories* on **Page 24**.

The only blower that can be used with the gravity kit is the UZY6.

The gravity kit must be used with the clean face kit to allow hot air flow that would normally come out of the top louver. To do so, follow the steps below:

- Install the clean face kit making sure that the insulation strip is installed inside.
- The fireplace façade can be covered with non-combustible material (**Figure 22**).

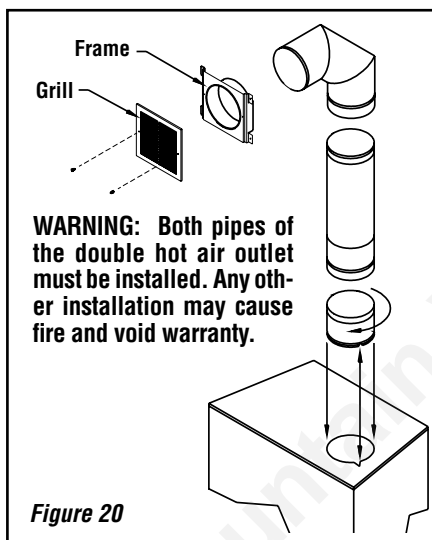

For safe installation, the gravity kit must meet the following requirements:

Minimum height* 68" (1,727 mm)
Maximum length See **Figures 20 and 21**

* The height of the louver must be measured from the base of the Brentwood LV fireplace to the middle point of the louver.

To extend the double outlet system forward of the Brentwood LV fireplace (not flush), it will be necessary to purchase two adjustable lengths (H8951).

When installing the double outlet system, the hot air outlets can be installed in the same room as the fireplace, or one or both of the outlets can be installed in adjacent or upper rooms. Installing the ducts at different elevations will tend to exhaust more heat out of the higher outlet (**Figure 21**).

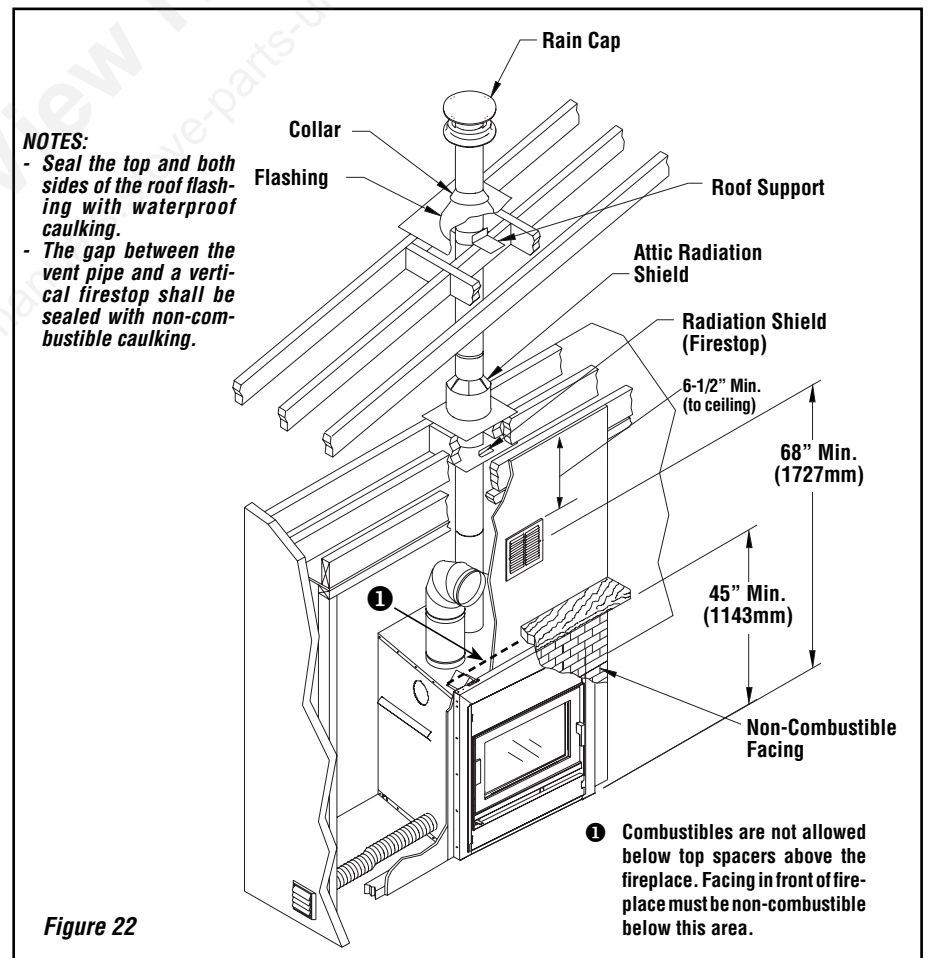
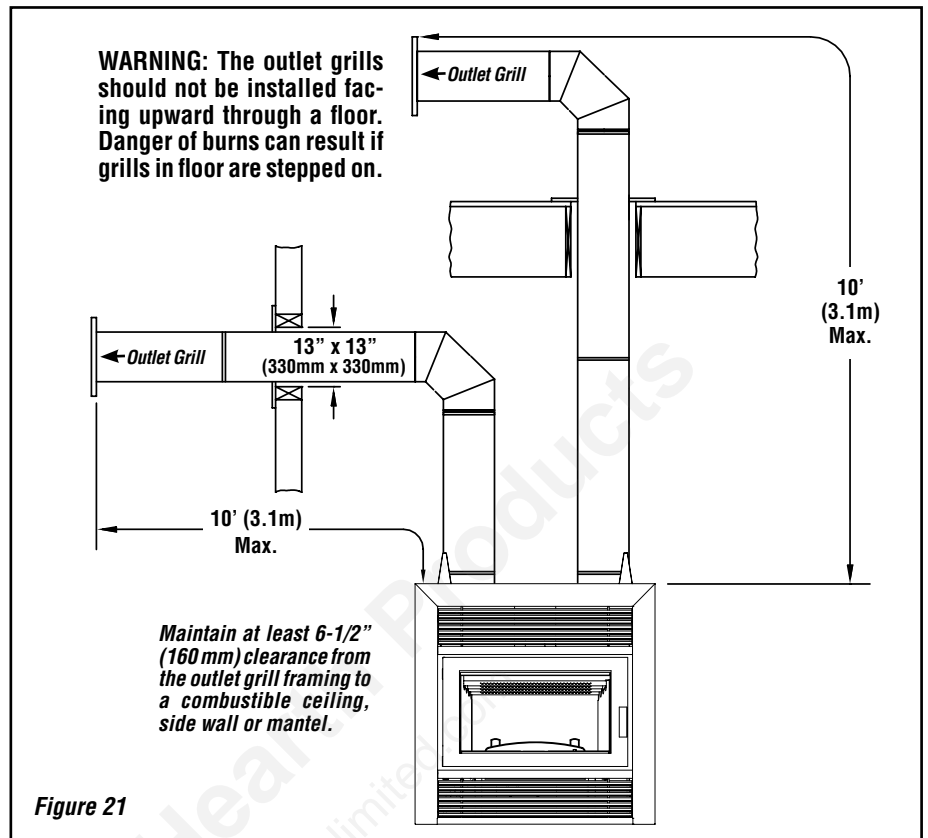

NOTE: DIAGRAMS & ILLUSTRATIONS ARE NOT TO SCALE.

The duct system must be installed respecting the following:

1. Remove the plates closing up the 8" dia. holes on top of the fireplace. Then, cut the insulation and remove the plate under the insulation in order to obtain two 8" dia. openings. Fix the adaptors on the fireplace openings by turning clockwise (**Figure 20**).
2. Maintain at least a 2" (50 mm) clearance between the ducts and any combustible material; the required hole size is 13" x 13" (330 mm x 330 mm).

Exception #1: For the grills, the framing can be 10-3/4" x 10-3/4" (275 mm x 275 mm) to provide the clearance as required by the integral spacers on the double outlet duct system.

3. The maximum number of elbows in a run of duct is two.
4. Maintain at least 6-1/2" (160 mm) clearance from the outlet grill framing to a combustible ceiling, side wall or mantel.
5. When traversing a combustible wall or floor, a firestop must be installed at the wall or floor penetration. The hole size must be 13" X 13" (330 mm x 330 mm).
6. Do not connect the hot air ducts to a central heating system. Malfunction of the heating system's blower will cause the fireplace to overheat. A furnace duct is only single wall and not double wall as is required for the Brentwood™ LV fireplace hot air exhaust.
7. Use only IHP grills and components as described in this manual. Other grills or registers, for example, may be too restrictive and may overheat the fireplace or ceiling.
8. Do not use insulated flexible ducts as they will overheat.
9. Do not use tees or any other components than the ones specifically listed here.
10. Never allow the ducting to pitch down as hot air will be trapped creating a fire hazard. **Never route the ducting downwards.**
11. The hot air outlet grills must be installed with the louvers pointing downwards in order to prevent overheating adjacent ceilings.
12. Always install the two outlet grills when using the double hot air outlet kit and blocking the upper louver of the fireplace.

CENTRAL FORCED AIR KIT (NOT TESTED UNDER EPA CERTIFICATION)

The knock-outs provided on the back and on the sides of the Brentwood™ LV fireplace allow the connection of insulated flexible pipe which enables you to heat adjacent rooms up to 50 feet from the fireplace.

The ducting system must be installed as described below:

- A) Remove the knock-out and cut the insulation. In the back, there may be another knock-out to remove under the insulation.
- B) Fix the adaptor at the back and/or the side of the fireplace by twist-locking the adaptor to the fireplace. You can use more than one outlet on the fireplace (**Figure 23**).
- C) Attach the 5" flexible pipe, using the collars provided. Important: Make sure that the plastic wrapping around the flexible pipe will not be in contact with the fireplace using aluminum tape.

- D) Route the flexible pipe to the chosen location. The ducting system can be installed either in an upper room or in a lower room.
- E) Attach the flexible pipe to the fan, using the collars (**Figure 24**).
- F) Fix the back draft damper to the fan outlet.
- G) Attach a flexible pipe to the fan / flexible pipe adaptor (square to round) and stretch it up to the location where the heat is required.
- H) At that point, the flexible pipe can be attached to any air distribution grill.
- I) Install the blower heating and cooling thermostat (HCTW) in that part of the house to be heated by the hot air duct. The thermostat can be switched to a cooling thermostat and installed in the same room as the unit. This thermostat will turn on the blower when the room where the fireplace is located becomes too hot.

This option requires electricity. Make sure that the connections to the fan have been made according to the local codes and comply with their requirements (see instruction provided with the thermostat).

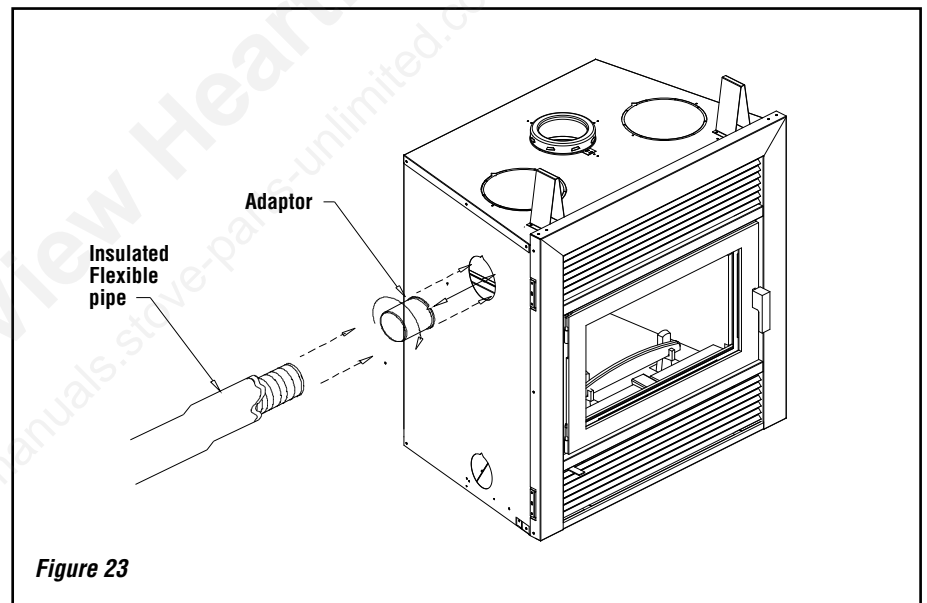

Figure 23

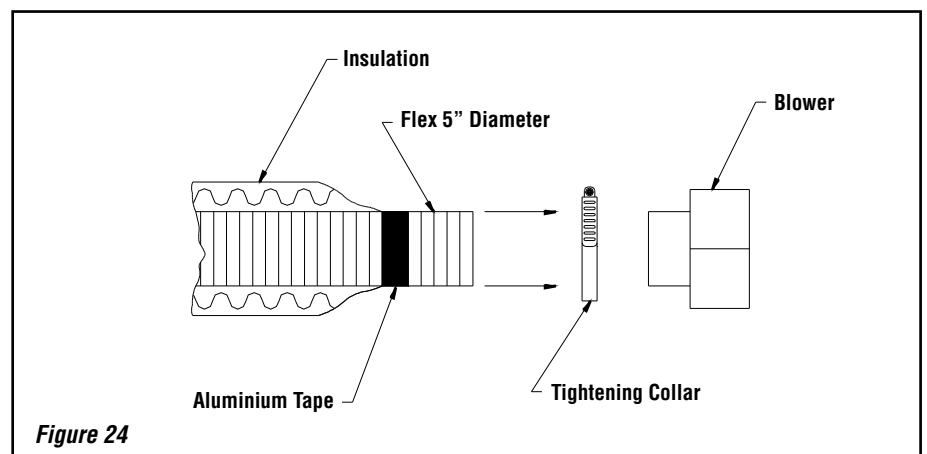

Figure 24

NOTE: DIAGRAMS & ILLUSTRATIONS ARE NOT TO SCALE.

OUTSIDE AIR KIT - REQUIRED (Included w/fireplace)

During operation, the fireplace requires fresh air for combustion and draws air out of the house. It may starve other fuel burning appliances such as gas or oil furnaces. As well, exhaust blowers may compete for air, causing negative pressure in the house, resulting in smoke entering the house from the fireplace. This situation is aggravated in modern airtight houses. To overcome this problem, we strongly recommend that you install an outside air assembly. Check with local authorities having jurisdiction in your area, it may be mandatory.

NOTE: Should you decide not to install the outside air assembly, proceed as follows:

- Remove the bottom grill. The air box is located on front left and is on a slant.
- Unscrew the four screws holding the inside air box covering plate and remove it.

Outside Air Installation

The outside air assembly may be installed according to the following requirements:

- Duct length should be kept to a minimum. The maximum length of duct is twenty (20) feet (6.1 m) for a 4 in. dia. pipe (See note below).
- The air intake register must not be installed more than ten (10) feet (3050 mm) above the base of the fireplace.
- The fresh air must come from outside the house. The air intake must not draw air from the attic, from the basement or garage.
- The air intake should be installed where it is not likely to be blocked by snow or exposed to extreme wind and away from automobile exhaust fumes, gas meters and other vents.
- The duct and register may be installed above or below floor level.

The following components are required:

- Outside air kit (UZI) (includes 4 inch flex that goes up to ten (10) feet long)
- 4" Adaptor for fireplace connection (supplied with the unit)

Make a 4-1/4" (110 mm) hole in the outside wall of the house at the chosen location. From outside, place the outside air register in the hole (open side down) and fasten the register to the wall, with screws as shown (see **Figure 25**). Slip the pipe into the insulated sleeve. Place the insulated pipe over the register tube and over the fireplace's outside air connector (see **Figure 26**). At each end, carefully pull back the insulation and plastic cover exposing the flexible pipe. Using the aluminium tape provided, wrap the tape around the joint between the flexible pipe and the air inlets. Carefully push the insulation and plastic cover back over the pipe. Using aluminium tape, fasten the plastic cover in place.

NOTE: We recommend not to exceed 20 feet of 4" flexible pipe. If you require a longer length we recommend that you use a 5" diameter flexible pipe for the complete run up to 30 feet and a 6" diameter pipe for a run of up to 40 feet.

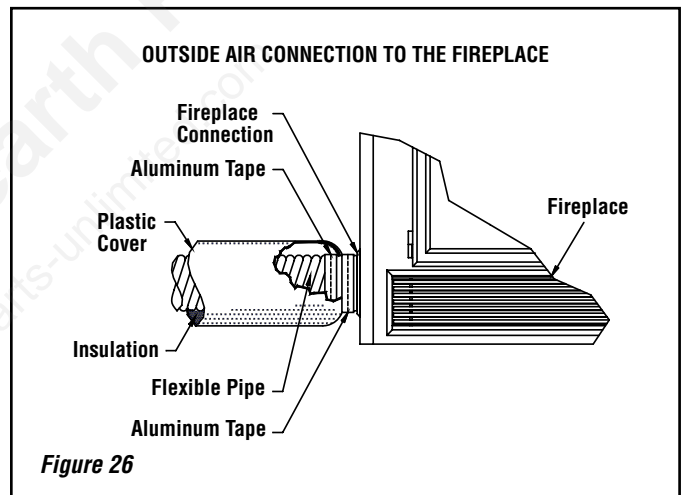
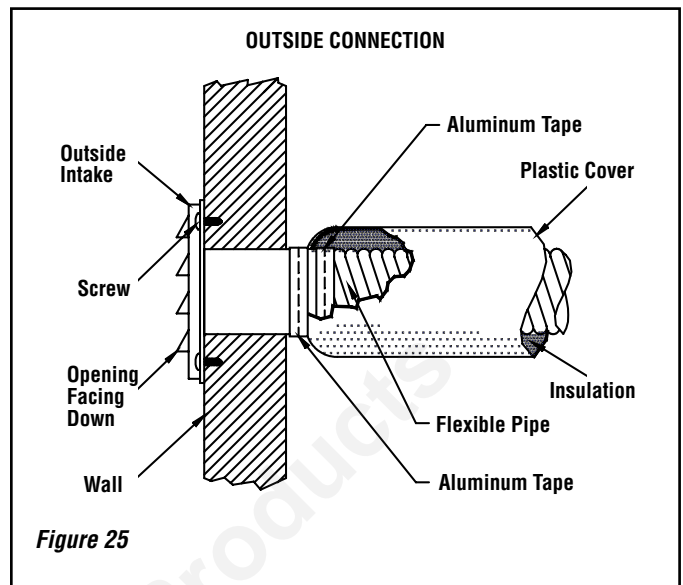

NOTE: DIAGRAMS & ILLUSTRATIONS ARE NOT TO SCALE.

THE CHIMNEY SYSTEM

Chimney Installation Notes

1. This appliance is equipped with a universal vent collar that will require the first vent section of pipe to be secured with four screws to the collar (equally spaced around circumference).
2. Always install an interior chimney as it will provide better performance. In areas with continuous temperatures below 0° F (- 18° C), the use of an exterior chimney increases the likelihood of operating problems such as low draft, high rate of creosoting, and poor start-up characteristics. Exterior chimneys are also prone to down drafting and flow reversal. Installations, which are located on lower floors in the house, such as in a basement, in combination with outside chimney, are especially prone to flow reversal. If interior installation is impossible, install an AC chimney enclosed in an insulated chase.
3. The fireplace model Brentwood™ LV may be installed only with Security Chimneys® Ltd 6" diameter chimney systems* or DuraVent models DuraTech® and DuraTech® DTC chimney systems**.
4. A chimney venting a fireplace shall not vent any other appliance.
5. The minimum chimney height is 12 feet (3.7 m). In altitude, add 18" (450 mm) to the chimney for every 2,000 feet (600 m) above sea level.
6. **All chimney installations must include at least one support.** The maximum length of chimney that can be supported by the fireplace is 26 feet (8 m).
7. The chimney must extend at least three (3) feet (915 mm) above its point of contact with the roof and at least two (2) feet (610 mm) higher than any wall, roof or building within ten (10) feet (3m) of it (**Figure 27**).
8. If the chimney extends higher than five (5) feet (1,500 mm) above its point of contact with the roof, it must be secured using a roof brace.
9. A rain cap must be installed on top of the chimney. Failure to install a rain cap may cause corrosion problems.

10. Cut and frame square holes in all floors, ceilings, and roof that the chimney will go through to provide a 2" (50 mm) clearance between the chimney and any combustible materials. Do not fill this 2" space with insulation or any other combustible material.
11. Portions of the chimney which may extend through accessible spaces must be enclosed to avoid contact with combustible materials or damage to the chimney.
12. When offsets are used, the pipe may not penetrate a ceiling or floor unless it is running vertical (no 30° offsets).

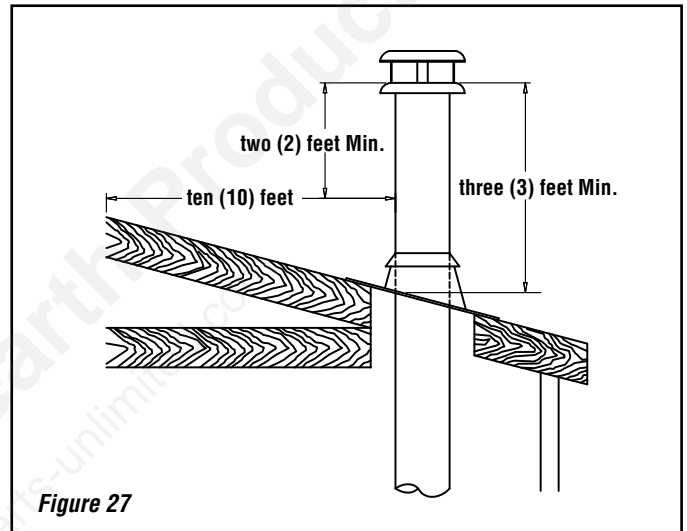

Figure 27

NOTE: 2" clearance to combustibles around chimney components required.

NOTE: Blown or fill type insulation materials must not be in contact with the fireplace or in the enclosure frame as described in "Enclosure" section.

NOTE: Local codes may not require firestopping at the ceiling levels for outside chase installations. However, it is recommended for safety and the reduction of heat loss.

CHIMNEY INSTALLATION INSTRUCTIONS

1. Cut and frame the holes in the ceiling, floor and roof where the chimney will pass (see **Figure 28**). Use a plumb-bob to line up the center of the holes. The sizes are indicated in **Table 2** for the floor and ceiling holes and **Table 3 (Page 19)** for the roof holes.

CHIMNEY MODEL	SQUARE HOLE SIZE OPENING
ASHT / HT6103+ *	12-3/8" (314 mm)
DuraTech DTC **	12-3/8" (314 mm)
S-2100+ / HT6000+ *	14-1/8" (359 mm)
AC *	15 in (380 mm)

NOTE: See Table 3 for Sloped Roof Framing
Table 2 - Flat Roof Framing

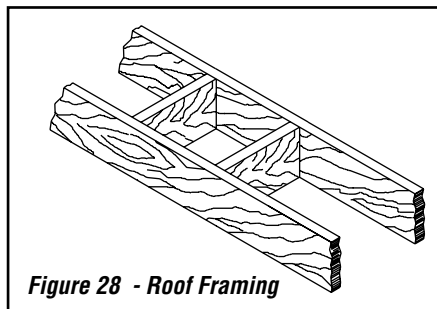

2. From below, install a firestop in each ceiling/ floor separation through which the chimney will pass. At the attic level, install an attic radiation shield from above (**Figures 29a through 29d**).
3. For ASHT*/ HT6103+*/ DuraTech DTC* and S2100+*/ HT6000+* chimneys place the first chimney length on the fireplace. To lock it in place, turn 1/4 of a turn clockwise. With the AC*chimney, you must use a starter section (**AC6SB* or AC6SB30***) before installing the first chimney length (**Figure 30**). Continue installing chimney lengths making sure to lock each length in place.
4. Every time the chimney passes through a ceiling or a wall, install the appropriate firestop. When you reach the desired height, install the roof support. When installing a support, slightly lift the chimney system so the weight will lie on the support, not on the fireplace to reduce expansion noises (Refer to instructions included with the support).
5. Then, put the roof flashing in place and seal the joint between the roof and the flashing with roofing pitch (see **Figures 30 and 31**). For sloping roofs, place the flashing under the upper shingles and on top of the lower shingles. Nail the flashing to the roof, using roofing nails.
6. Place the spacers and the storm collar over the flashing, and tighten it with the bolt supplied. Finally, seal the joint between the storm collar and the chimney, using silicone caulking.
7. Install the chimney cap. Once the chimney cap is in place, the roof flashing can be washed with a solvent or vinegar and then painted with rust-proof paint.

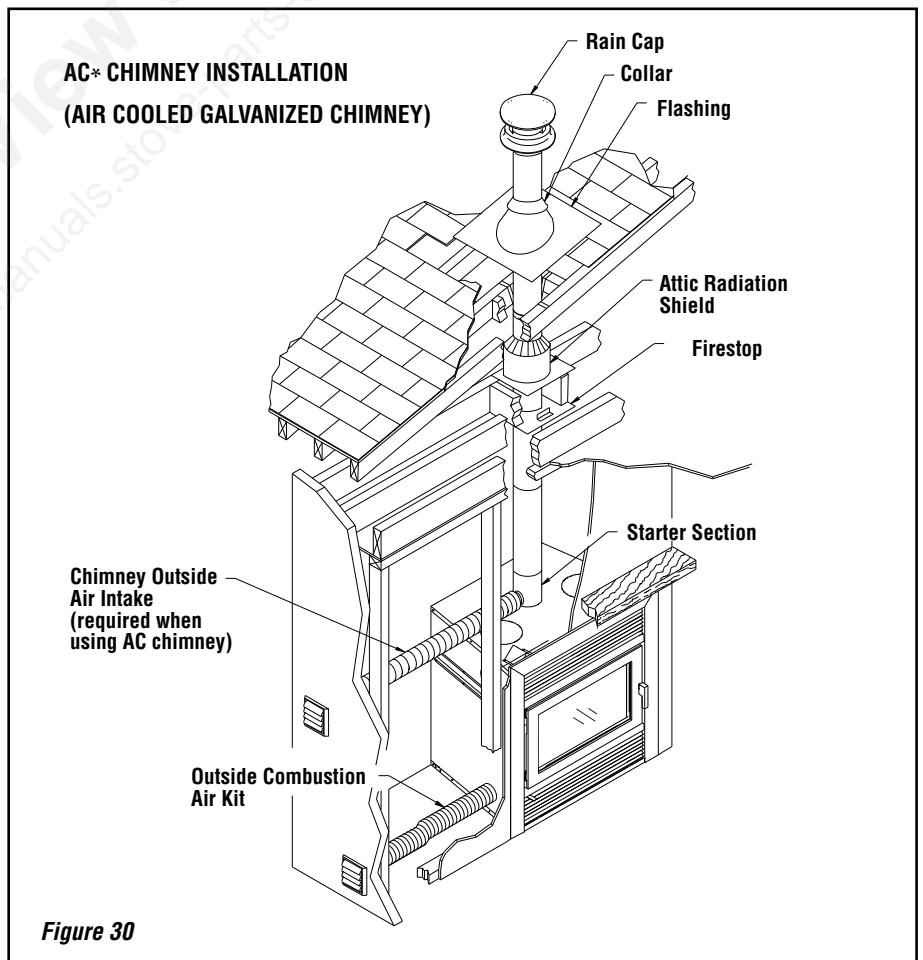
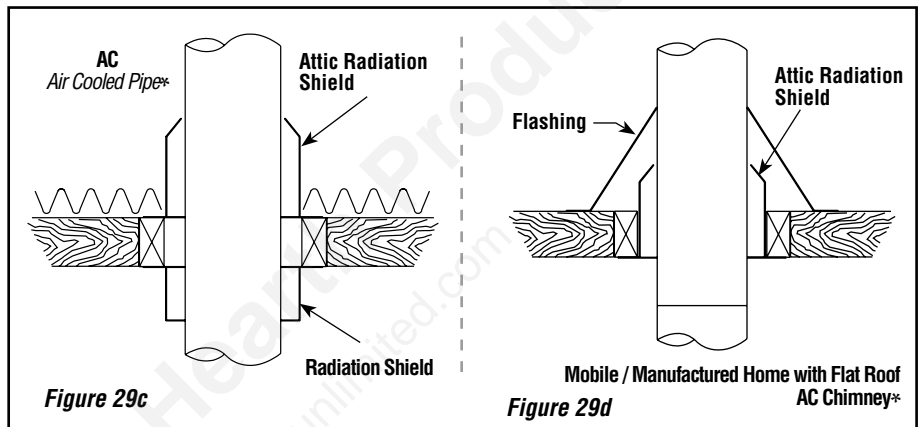
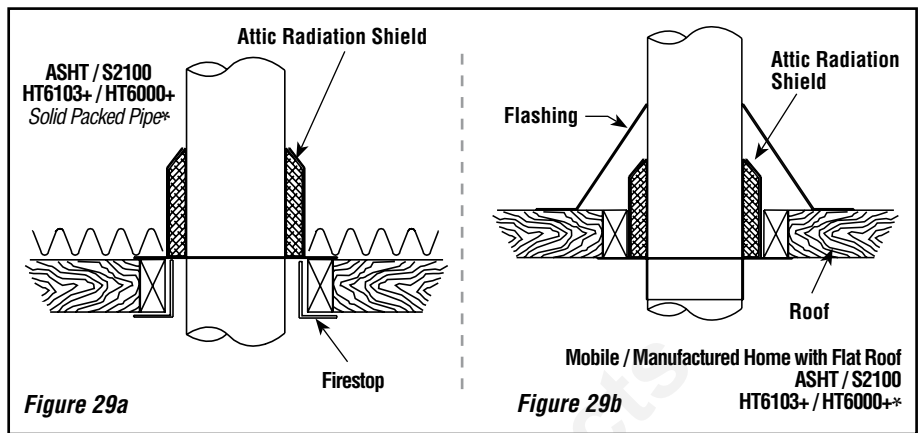

NOTE: DIAGRAMS & ILLUSTRATIONS ARE NOT TO SCALE.

*Available from Security Chimneys®
**Available from DuraVent®

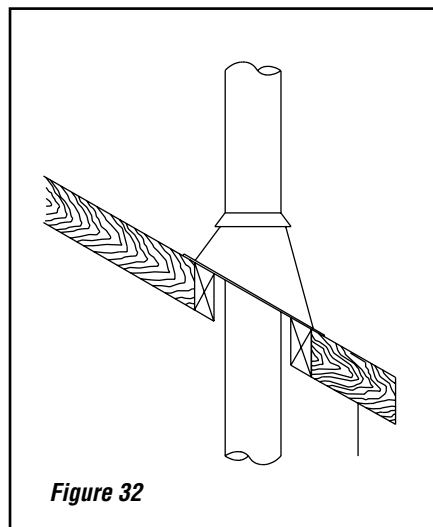
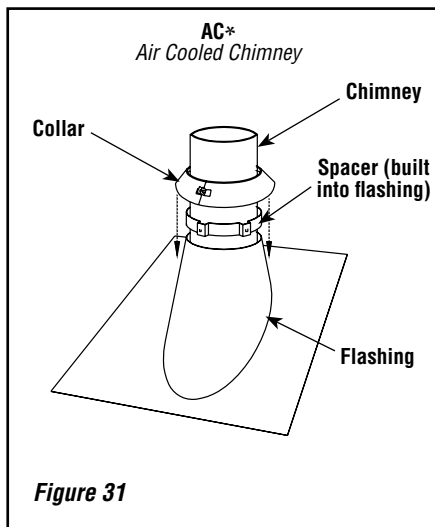

After reaching the location requiring the elbow, proceed as follows:

ASHT* / HT6103+* / S-2100+* / HT6000+* / DuraTech DTC* Chimneys

1. Install the first elbow; turn it in the required direction. Fasten it to the chimney with the three (3) 1/2" (12 mm) metal screws provided with the elbow.
2. Install the necessary chimney lengths to achieve the required offset. Lock the chimney lengths together: it is recommended to use three (3) 1/2" (12 mm) screws. If the offset length is made of two (2) chimney lengths or more, use an offset or roof support halfway up the offset. If penetrating a wall, install a wall radiation shield (see **Figures 34 and 36**).
3. Use another elbow to turn the chimney vertically. Secure the elbow, using three (3) 1/2" (12 mm) screws (provided with the elbow).
4. Use a plumb-bob to line up the center of the hole. Cut a hole for the chimney in the ceiling/floor. Frame this hole as described previously (refer to section *Chimney Installation Instructions*).
5. From below, install a firestop (See **Figure 29a**).
6. A support (ST* or SO+*) must be used on the first 15' section (5 m).
7. Continue with the regular installation.

AC Chimney*

1. Install the first elbow. Turn it in the required direction. To lock it in place, turn 1/8 of a turn. Fasten the straps attached to the elbow to the surrounding frame, using nails or drywall screws (**Figure 34**).
2. Install the necessary chimney lengths to achieve the required offset. Lock the chimney lengths together. If penetrating a wall, use a wall radiation shield.
3. Use another elbow to turn the chimney vertically. Lock it to the chimney. Fasten the straps attached to the elbow to the surrounding framing using nails or drywall screws.
4. Use a plumb-bob to line up the center of the hole. Cut a hole for the chimney in the ceiling. Frame this hole as described previously.
5. From below, install a firestop (see **Figure 29c**).
6. Continue with the regular installation.

NOTE: When using AC chimney, an AC6SB* starter section must be used before installing an elbow. When an offset is needed immediately off the top of the fireplace, an elbow starter section, AC6SB30*, is available.

Roof Down Slope Hole Size			
SLOPE	ASHT* / HT6103+* / DuraTech DTC*	S-2100+* / HT6000+*	AC*
Roof Pitch	6"	6"	6"
0 *	12-3/8" (314 mm)	14-1/8" (359 mm)	15" (380 mm)
2/12	12-9/16" (319 mm)	14-3/8" (365 mm)	15-3/8" (390 mm)
4/12	13" (330 mm)	14-7/8" (378 mm)	16-1/8" (410 mm)
6/12	13-7/8" (352 mm)	15-3/4" (400 mm)	16-7/8" (430 mm)
8/12	14-7/8" (378 mm)	17" (432 mm)	18-1/4" (465 mm)
10/12	16-1/8" (410 mm)	18-3/8" (467 mm)	19-5/8" (500 mm)
12/12	17-1/2" (445 mm)	20" (508 mm)	21-3/8" (545 mm)

* Cross Slope Hole Size
Put the chimney cap into place.
Wash the roof flashing with a solvent or vinegar, then paint it with rust-proof paint.

Table 3

OFFSET CHIMNEY INSTALLATION

After reaching the location requiring the elbow, proceed as follows. The minimum chimney height when using elbows is:

Minimum Chimney Height Using Elbows	
Fireplace Model	Brentwood™ LV
Chimney Model	ASHT* / S2100+* / HT6103+* / HT6000+* / AC* / DuraTech DTC*
Vertical installation	12 feet (3.66 m)
Two (2) elbows	15 feet (4.57 m)
Four (4) elbows	17 feet (5.18 m)

Table 4

NOTES:

- Must return to vertical before penetrating ceiling or floor.
- A maximum of 2 offsets are allowed.

Offset Dimensions

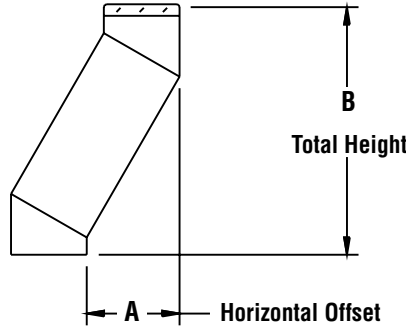

Chimney 6"	Elbow	Offset & Height	One Length Between Elbows						Two Lengths Between Elbows					
			8"	12"	18"	24"	36"	48"	8" & 48"	12" & 48"	18" & 48"	24" & 48"	36" & 48"	48" & 48"
Secure Temp® ASHT**	15°	A	3-5/16" (84mm)	4-5/16" (110mm)	5-7/8" (149mm)	7-7/16" (189mm)	10-1/2" (267mm)	13-5/8" (346mm)	15-3/8" (391mm)	16-7/16" (418mm)	18" (457mm)	19-1/2" (495mm)	22-5/8" (575mm)	25-3/4" (654mm)
		B	15-11/16" (398mm)	19-9/16" (497mm)	25-3/8" (645mm)	31-3/16" (792mm)	42-3/4" (1086mm)	54-3/8" (1381mm)	60-15/16" (1548mm)	64-13/16" (1646mm)	70-9/16" (1792mm)	76-3/8" (1940mm)	87" (2210mm)	99-9/16" (2529mm)
Nova Temp® HT6103+*	30°	A	7-7/16" (189mm)	9-7/16" (240mm)	12-7/16" (316mm)	15-7/16" (392mm)	21-7/16" (545mm)	27-7/16" (697mm)	30-13/16" (783mm)	32-13/16" (833mm)	35-13/16" (910mm)	38-13/16" (986mm)	44-13/16" (1138mm)	50-13/16" (1291mm)
		B	20" (508mm)	23-1/2" (597mm)	28-11/16" (729mm)	33-7/8" (860mm)	44-1/4" (1124mm)	54-11/16" (1389mm)	60-9/16" (1538mm)	64" (1627mm)	69-1/4" (1759mm)	74-7/16" (1891mm)	84-13/16" (2154mm)	95-1/4" (2419mm)
DuraTech® DTC+*	45°	A	10-5/16" (262mm)	13-3/16" (335mm)	17-3/8" (441mm)	21-5/8" (549mm)	30-1/8" (765mm)	38-5/8" (981mm)	43-7/16" (113mm)	46-1/4" (1175mm)	50-1/2" (1283mm)	54-3/4" (1391mm)	63-1/4" (1607mm)	71-11/16" (1818mm)
		B	17-13/16" (452mm)	20-5/8" (524mm)	24-7/8" (632mm)	29-1/8" (740mm)	37-5/8" (956mm)	46-1/8" (1172mm)	50-15/16" (1294mm)	53-3/4" (1365mm)	58" (1473mm)	62-1/4" (1581mm)	70-3/4" (1797mm)	79-3/16" (2011mm)

Chimney 6"	Elbow	Offset & Height	One Length Between Elbows						Two Lengths Between Elbows					
			8"	12"	18"	24"	36"	48"	8" & 48"	12" & 48"	18" & 48"	24" & 48"	36" & 48"	48" & 48"
Secure Temp S2100+ *	15°	A	3-5/16" (84mm)	4-5/16" (110mm)	5-7/8" (149mm)	7-7/16" (189mm)	10-1/2" (267mm)	13-5/8" (346mm)	15-1/2" (394mm)	16-1/2" (419mm)	18-1/16" (459mm)	19-5/8" (498mm)	22-3/4" (578mm)	25-13/16" (656mm)
		B	16" (406mm)	19-7/8" (505mm)	25-11/16" (652mm)	31-1/2" (800mm)	43-1/16" (1094mm)	54-5/8" (1387mm)	61-7/16" (1561mm)	65-1/4" (1657mm)	71-1/16" (1805mm)	76-7/8" (1953mm)	88-1/2" (2248mm)	100-1/16" (2542mm)
Nova Temp HT6000*	30°	A	7-3/8" (187mm)	9-3/8" (238mm)	12-3/8" (314mm)	15-3/8" (391mm)	21-3/8" (543mm)	27-3/8" (695mm)	30-7/8" (784mm)	32-7/8" (835mm)	35-7/8" (911mm)	38-7/8" (987mm)	44-7/8" (1140mm)	50-7/8" (1292mm)
		B	20-11/16" (525mm)	24-3/16" (614mm)	29-3/8" (746mm)	34-9/16" (878mm)	44-15/16" (1141mm)	55-5/16" (1405mm)	61-3/8" (1559mm)	64-7/8" (1648mm)	70-1/16" (1780mm)	75-1/4" (1911mm)	85-5/8" (2175mm)	96" (2438mm)

Chimney 6"	Elbow	Offset & Height	One Length Between Elbows						Two Lengths Between Elbows					
			---	12"	18"	---	36"	48"	---	12" & 48"	18" & 48"	---	36" & 48"	48" & 48"
AC* 6"	15"	A	---	4-13/16" (122 mm)	6-1/8" (156 mm)	---	11" (280 mm)	14-1/8" (359 mm)	---	16-7/8" (429 mm)	18-7/16" (468 mm)	---	23" (584 mm)	26-3/16" (665 mm)
		B	---	27-11/16" (703 mm)	33-1/2" (851 mm)	---	50-7/8" (1292 mm)	62-1/2" (1588 mm)	---	72-5/8" (1845 mm)	78-7/16" (1992 mm)	---	95-3/4" (2432 mm)	107-3/8" (2727 mm)
	30"	A	---	9-3/8" (238 mm)	12-3/8" (314 mm)	---	21-3/8" (543)	27-3/8" (695 mm)	---	32-5/8" (829 mm)	35-5/8" (905 mm)	---	44-5/8" (1134 mm)	50-5/8" (1286 mm)
		B	---	25-3/4" (654 mm)	31" (787 mm)	---	46-1/2" (1181 mm)	57" (1448 mm)	---	66" (1676 mm)	71-1/4" (1810 mm)	---	86-7/8" (2207 mm)	97-1/4" (2740 mm)

NOTE: With the AC* chimney, a starting section must be used on top of the fireplace.

Figure 33

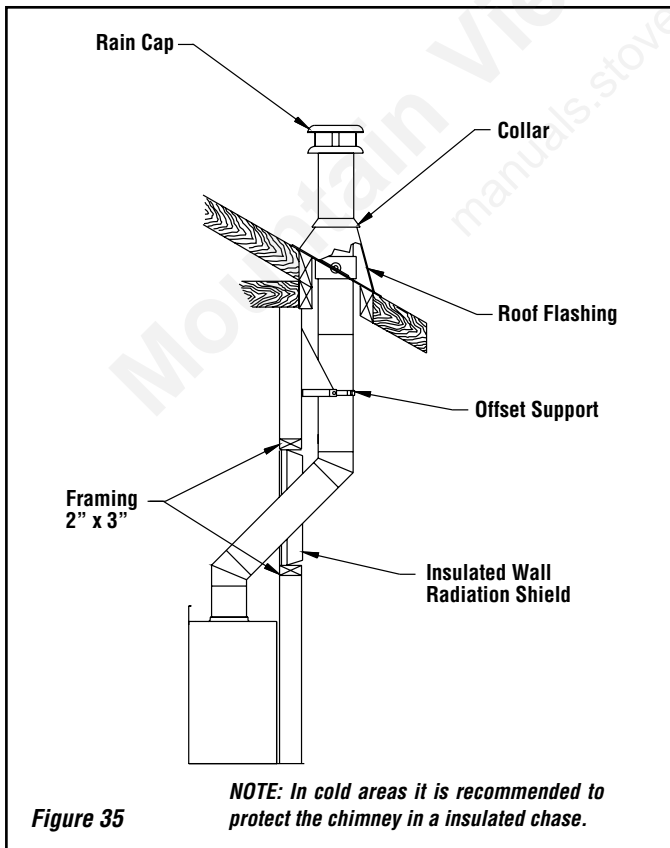
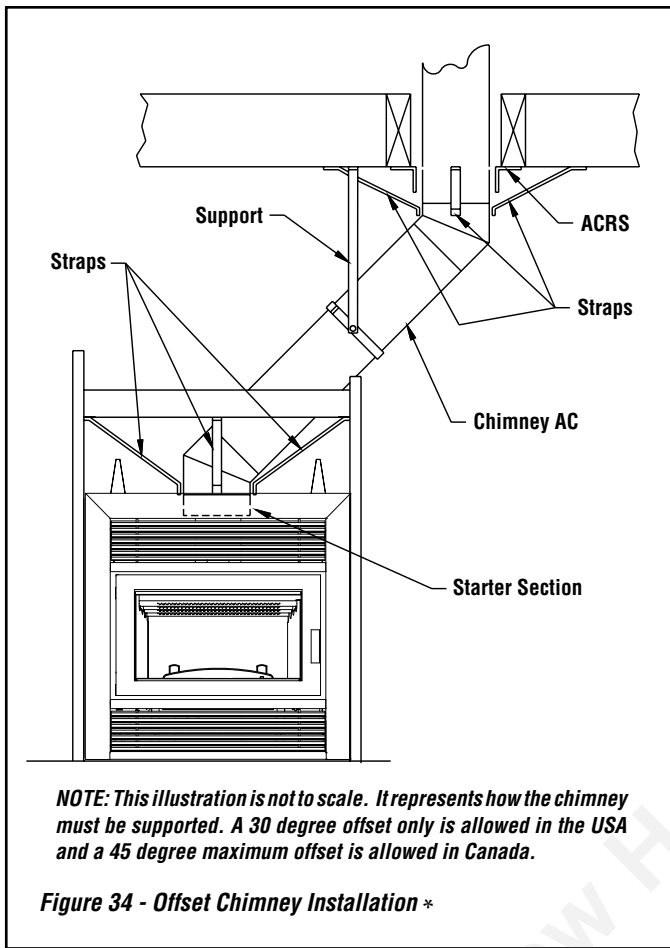

ANGLED WALL RADIATION SHIELD

When traversing a combustible wall with the chimney at a 30° or 45° angle, an angled firestop or wall radiation shield must be installed. Only one is required.

NOTE: 45° angle for Canada only (RSMI45* / 6DTC-S45)**

In cold climate locations (climates where temperatures will fall below 32° F / 0° C), we recommend that you use the insulated wall radiation shield since it will maintain the home's thermal barrier.

Security Chimneys® RSM+ and RSMI30 (RSMI45 - Canada Only)		DuraVent® 6DTC-WTI and 6DTC-S30 (6DTC-S45 - Canada Only)	
Chimney Model	Angle	Hole Size	
ASHT / HT6103+ (6" dia). Canada only	30°	283 mm x 781 mm (11-1/8" x 30-3/4")	
	45°	283 mm x 518 mm (11-1/8" x 20-3/8")	
DuraTech DTC ** (6" dia). Canada only	30°	283 mm x 781 mm (11-1/8" x 30-3/4")	
	45°	283 mm x 518 mm (11-1/8" x 20-3/8")	
S-2100+ / HT6000+ / AC (6" dia).	30°	327 mm x 881 mm (12-7/8" x 34-11/16")	
	30°	380 mm x 972 mm (15" x 38-1/4")	

Table 5

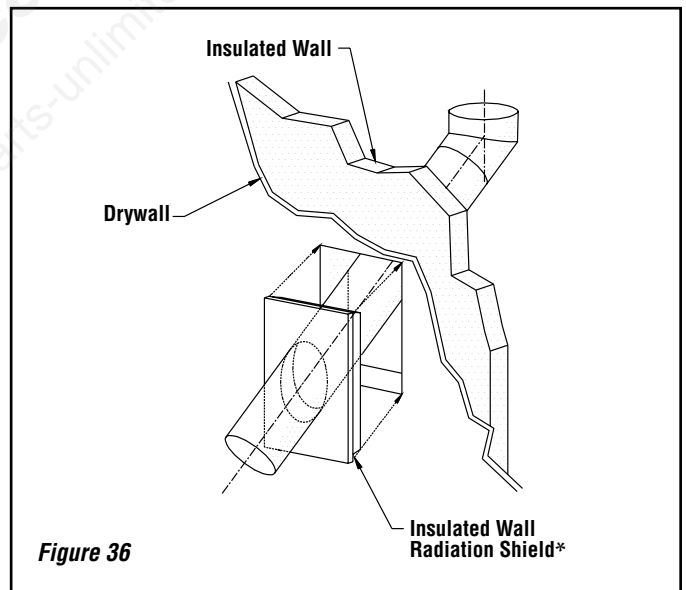

CHIMNEY SUPPORT INSTALLATION

Universal Roof Support*

When installing a support, slightly lift the chimney system so the weight will lie on the support, not on the fireplace to reduce expansion noises. This support has three possible uses:

1. For ASHT* / HT6103+* and S-2100+* / HT6000+* / DuraTech® DTC*, it must be used on a roof to support the chimney.
2. It may be used on a floor, ceiling or roof above an offset to support the chimney above the offset.
3. It may be used on a floor, ceiling or roof as a supplementary support.

Table 6 gives maximum height of supported chimney.

NOTE: For the AC chimney*, a support section must be used every 40 feet (12 m) instead of the universal roof support (ST*).

For roof support installation, refer to the instructions provided with the support.

Universal Offset Support*

This support is used to support the chimney above an offset. When the chimney offset is used to traverse a wall this support may be used on the wall to support the chimney. The maximum heights are given in **Table 6**. For offset support installation, refer to the instructions provided with the support.

Chimney Model	MAXIMUM HEIGHT OF SUPPORTED CHIMNEY	
	OFFSET SUPPORT	ROOF SUPPORT
ASHT / HT6103+ (6" dia). *	28 feet (8.54 m)	29 feet (8.84 m)
DuraTech DTC (6" dia). **	28 feet (8.54 m)	29 feet (8.84 m)
S-2100+ / HT6000+ (6" dia). *	18 feet (5.49 m)	20 feet (6.1 m)
AC (6" dia). *	40 feet (12.19 m)	50 feet (15.20 m)

Table 6

CHIMNEY CHASE AND MULTIPLE TERMINATIONS

For the purpose of this manual, a chimney chase is considered a part of the chimney system rather than part of a building. The termination must be placed a minimum of 18" (460 mm) above the chase.

For installations where more than one chimney is located in the same chase or within the same area, we suggest that their terminations be separated by at least 16" (410 mm) horizontally, and 18" (460 mm) vertically. This separation is to prevent smoke migrating from one chimney to another (see **Figure 37**).

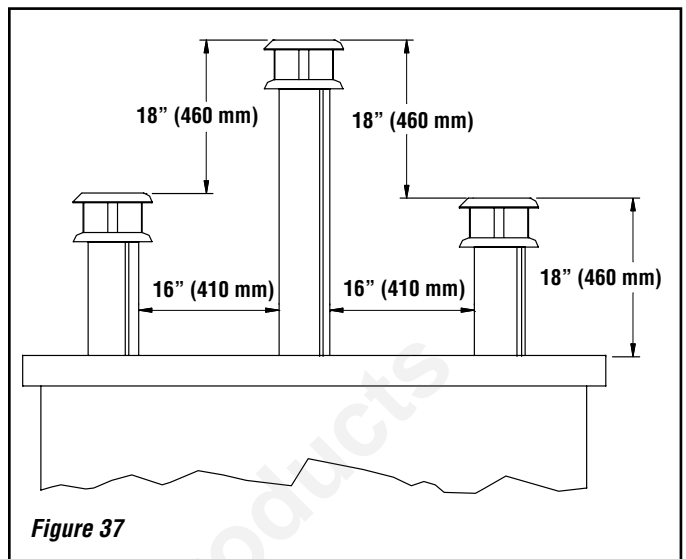

Figure 37

CHIMNEY ADAPTOR* (S-2100+ / HT6000+) CANADA ONLY

The fireplace is normally supplied with a chimney adaptor suitable for the ASHT / HT6103+ chimney*. If you want to install a S-2100+ / HT6000+ chimney, an adaptor is available (6UCA*) (**Figure 38**). A separate starter section will also be required if AC chimney* is installed.

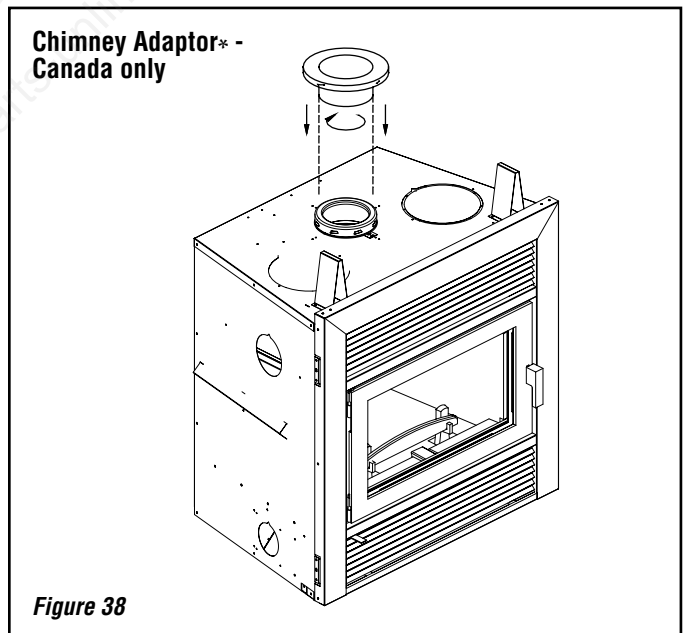

Figure 38

INSTALLATION INSTRUCTIONS FOR MASONRY APPLICATION

WARNING: Before starting the installation, the masonry chimney must be inspected by a qualified chimney sweep.

The following requirements must be respected:

1. The chimney must be absolutely clear of any soot residue or creosote. Check for cracks, loose or missing bricks that could inhibit correct installation of the liner.
2. The clearance to combustibles must be a minimum of 1" between the outside of the masonry and any wood framing or loose insulation.
3. The chimney must be built in accordance with the current building code.
4. No other appliance can be connected to the same chimney.
5. The clearances to combustibles for the BISUMA30* connectors are 2" on the side and bottom and 16" at the top.
6. **The connector parts are not necessary if the connection between the insulated length and the stainless steel liner is done within the masonry chimney.**

Installation:

The chimney must be relined with a stainless steel liner model Tubinox®* or Projet® SS* of the same diameter as the outlet of the fireplace. If a stainless steel liner is used, see note below**.

For connection at a 30° angle, a special connector (BISUMA30*) must be used to connect the liner to the insulated chimney.

*** IMPORTANT NOTE - The use of a 45° connector (BISUMA*) is approved for use in Canada ONLY. Installations in the USA must use the 30° connector (BISUMA30*).**

** Alternate brand rigid stainless liner or stainless flex may be substituted but must be listed to UL-1777 for US application and ULC-S635 for existing masonry or ULC-S640M for new masonry applications in Canada. The steel rigid or flex liner must be rated at 2100° F (1100° C).

Follow these steps:

1. Position the fireplace in its location. Temporarily install the ASHT* elbow on the top of the fireplace and, using a level, mark with an oval the location where the flue liner will enter the masonry chimney.
2. In the middle of the oval, drill a hole in the masonry chimney at 30°.
3. Increase the size of the hole until a 30° Tubinox* liner elbow can be easily slipped through.
4. Slide the liner down from the top of the masonry chimney until you reach the hole level.
5. Slip through the hole a 30° liner elbow and connect it to the liner.
6. Add a small liner section to the liner elbow which will allow the liner to extend at least 12" (measured at the top of the liner) from the masonry chimney.
7. Seal the opening around the liner with high temperature refractory cement.
8. The next steps must be done in the following order:

See typical installation illustrated below.

- A. Select the ASHT* length that will fit between the elbow and the liner so that it will slide at least 2" over the liner section (You may need to cut the liner for a better fit).
- B. Take that section and the BISUMA30* cover and slide it over the liner. Make sure you have enough opening to be able to install the ASHT* elbow without difficulty.
- C. Install the 30° elbow on the fireplace.
- D. Slide the length section back down on the elbow and twist lock the two together.
- E. Pull the cover down over the length and install the insulation pad over the liner; be careful to cover the liner completely.
- F. Slide back the cover over the insulation and fix it in place using the 3 metal screws supplied.

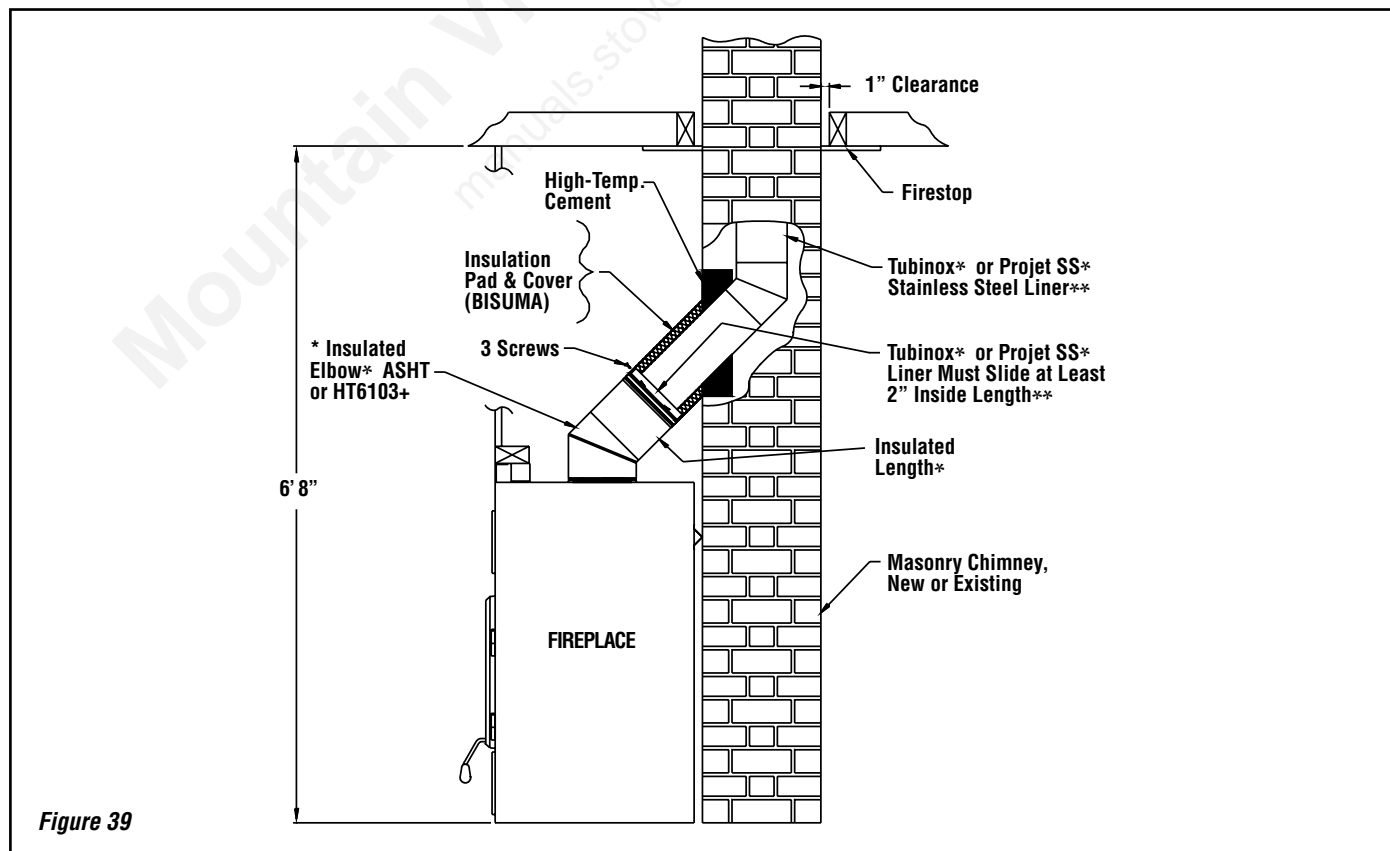

Figure 39

NOTE: DIAGRAMS & ILLUSTRATIONS ARE NOT TO SCALE.

*Available from Security Chimneys®

**Available from DuraVent®

OPTIONAL INSTALLATION ACCESSORIES

Installation Accessories	
Description	Cat./Part No.
Finishing Kits (Required - Order Separately)	
Louver kit	LOUVRECF
OR	
Clean face kit	CAPPINGCF
Outside Air Kit (Required - included w/fireplace)	
Outside Air Coupler to connect outside air UZI to fireplace, UZIAD	UZIAD
Outside Air Ducting - includes 4" insulated flex x 10' long, UZI	UZI
Gravity Kits (REQUIRED WITH CLEAN FACE KIT)	
Gravity Kit - Complete double ducting system w/adaptor including: 2 elbows 90°, 2 telescopic lengths, 2 grill supports and 2 black grills, 7B30ZK-1	H8947
Gravity Kit Accessories	
Elbow 90°, 8" dia., 7B26ZE90	H8948
Elbow 45°, 8" dia., 7B26ZE45	H8949
Telescopic length, 8" dia. (15" to 26"), 7B26ZLA	H8950
Adjustable length 8" dia (2" - 5"), 7B26ZL2A	H8951
Length two (2) feet, 8KL2	H8954
Length one (1) feet, 8KL1	H8953
Wall radiation shield, 8" I.D., 7B26ZR	H8952

Fireplace Kits	
Description	Cat./Part No.
Blower motor speed control (wall mount), VRUW	VRUW
Rigid Firescreen ❶	BUCFZN
Central Forced Air Kit Accessories ❶	
Central Forced Air Kit, Central forced air kit including: blower (BISZY), flex adaptor (BISAF), 2 clamps, variable speed control (VRUW), thermo-disk (VTU), fan to flexible pipe adaptor (BISAVF), back draft damper (BISBD), aluminium tape, BISFWK-1	BISFWK-1
Flexible pipe 5" I.D. x 15 ft. Long, 5FLEX15	5FLEX15
Flexible pipe 5" I.D. x 30 ft. Long, 5FLEX25	5FLEX25
Heating and cooling thermostat, 24V, HCTW	HCTW

❶ **Not tested under EPA certification. If installed, this appliance no longer qualifies for EPA certification. Check with local authorities having jurisdiction for requirements in your area.**

REPLACEMENT PARTS - BRENTWOOD™ LV

Brentwood™ LV		
Item #	Description	Cat./Part No.
1	Baffle refractory (2 pieces)	PR-IS02205
2	Back refractory	PR-SR2996
3	Right side refractory	PR-SR2997D
4	Left side refractory	PR-SR2997G
5	Bottom refractory	PR-SR2201
6	Front refractory, right side - ash lip	PR-SR2202D
7	Front refractory, left side - ash lip	PR-SR2202G
8	Secondary air tube	PR-SR2271
9	Bracket, secondary air tube lock	PR-SR2214
10	Facing: Top trim	PR-SR3033
11	Bottom trim	PR-SR3020
12	Top frame	PR-SR2995
13	Left side frame	PR-SR2994G
14	Right side frame	PR-SR2994D
15	Fireplace top	PR-SR2500
16	Fireplace left side	PR-SR2502
17	Fireplace right side	PR-SR2503
18	Fireplace back	PR-SR2499
19	Touch-up paint, aerosol, black metallic SBMB6309	H8159
20	Louvers, upper and lower (set of 2)	LOUVRECF
21	Complete door	PR-SR3003LV
22	Wooden door handle	PR-SR2856
23	Door handle rod and lock	PR-SR2855
24	Ceramic glass panel	PR-SR3004
25	Gasket, door, 77-3/4" (3/4" dia.)	PR-SR18230
26	Gasket, glass, 74" (3/16" x 1")	PR-SR1685J
27	Hinge assembly, fireplace and door	PR-SR1933
28	Blower (heat activated on/off, pre-wired), V2	F3270
29	Snap Disc, Blower	VTU
30	Andiron (2)	PR-SR2324
31	Cast iron log retainer bar	PR-SR2323
---	Blower 250 CFM for central forced air kit, BISZY	BISZY
---	Blower variable speed control with decorative wall plate for (BISZY), VRUW	VRUW
---	Thermo-disk, on/off blower control (for BISZY), VTU	VTU
---	Blower to flexible pipe adaptor, BISAVF	BISAVF
---	Backdraft damper, BISBD	BISBD
---	Fireplace to Flex adaptor and 2 clamps, BISAF	BISAF

Contact an IHP dealer to obtain any of these parts. Never use substitute materials not approved by IHP. Use of non-approved parts can result in poor performance and safety hazards.

SPECIFICATIONS

Cat. No.	Model
H8295	Brentwood™ LV

Model	Emission Rate	Heat Output	EPA Estimated Efficiency
Brentwood LV	3.7 g/hr	10,442-27,746 btu/hr	63%

Product Reference Information	
Weight	385 lbs
Height	36"
Width	36"
Depth	24-1/2"
Firebox W x H x D - measured in front	22" x 11-3/4" x 12"
Chimney weight ASHT (6" dia)	6.25 lb per linear foot
Chimney weight AC (6" dia)	3.25 lb per linear foot

CLEARANCE TO COMBUSTIBLES

The following clearances meet the minimum requirements for a safe installation:

Side wall: 24" (610 mm) measured from the fireplace side.

Ceiling: 6' 8" (2,032 mm) measured from the base of the fireplace.

Fireplace enclosure:

Bottom: 0"

Side: 0" to spacer

Back: 0" to spacer

Top: Do not fill the space above the fireplace with any material (Except the wood framing. See **Page 11, Figure 11**).

Chimney: 2" (50 mm)

Mantel: 45" (1143 mm) measured from the base of the fireplace.

REPLACEMENT PARTS - BRENTWOOD™ LV

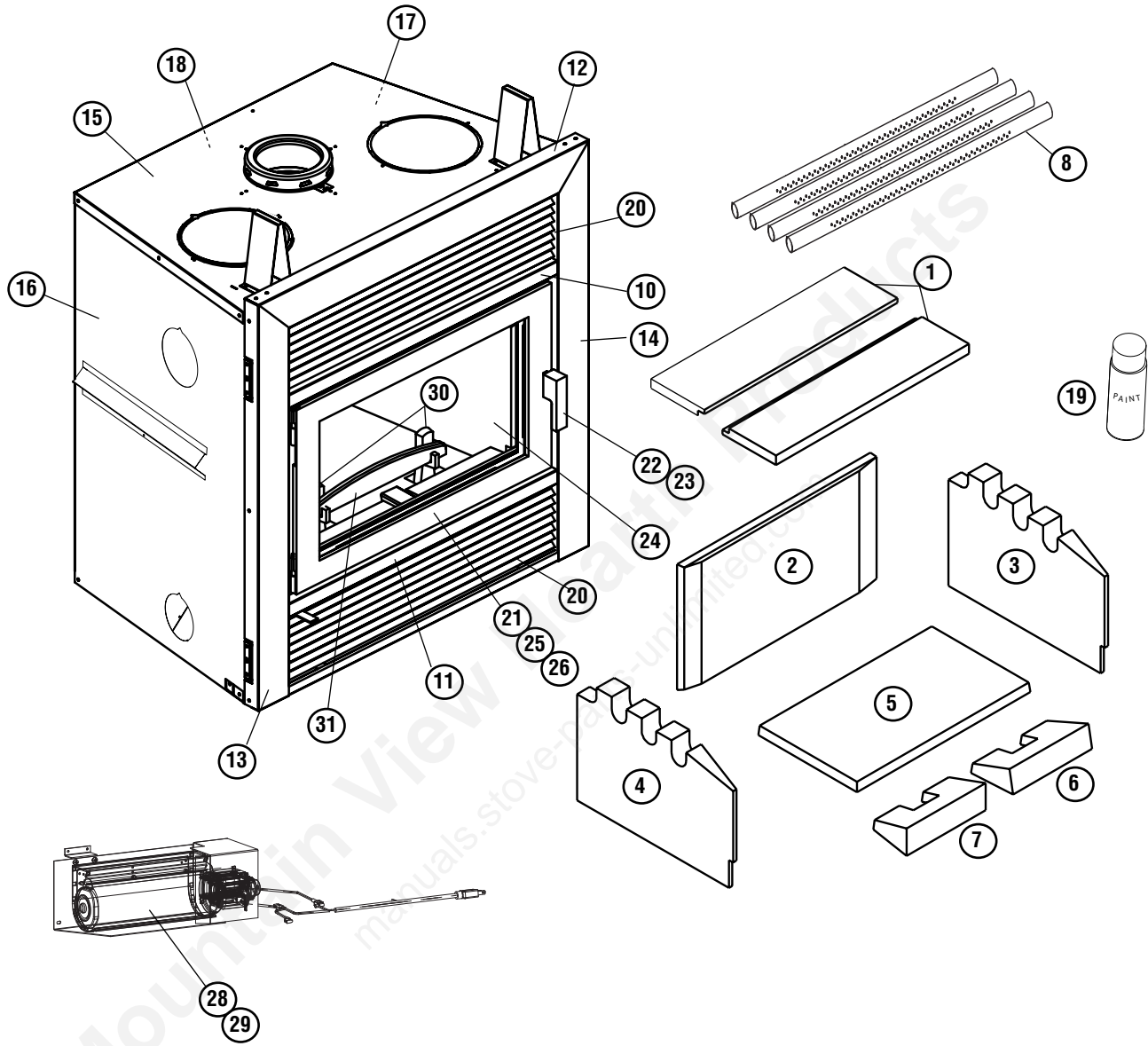

SECURITY CHIMNEYS® AND DURAVENT® - PARTS AND COMPONENTS LISTS

The components listed below must be ordered from Security Chimneys® or DuraVent®. Contact your Security Chimneys or DuraVent Distributor or Dealer for ordering information.

Security Chimneys® 2125 Monterey, Laval, Quebec Canada, H7L 3T6 securitychimneys.com	450-973-9999 1-800-361-4909 (USA) 1-800-667-3387 (Canada)
--	---

M&G DuraVent 877 Cotting Court, Vacaville, California, 95688 duravent.com	1-800-835-4429
---	----------------

Secure Temp ASHT 1" High Temp. Insulated Stainless Steel Chimney 6" I.D. and 8" O.D., Double-Wall Stainless Steel, Listed to CAN/UCL-S604, UL-103HT and CAN/ULC S629	
Description	Part/Cat. No.
Lengths and Misc. Chimney Components	
8" length, 6" Dia.	6L8
12" length, 6" Dia.	6L12
18" length, 6" Dia.	6L18
24" length, 6" Dia.	6L24
36" length, 6" Dia.	6L36
48" length, 6" Dia.	6L48
Adjustable Length 12", 6" Dia.	6LA
15° elbow, 6" Dia.	6E15
30° elbow, 6" Dia.	6E30
Rain Termination Cap, 6" Dia.	6CC
Spark Arrester Screen (universal spark arrester band)	PE
Wall Band	BM
Supports	
Offset Support	S0
Roof Support	ST
Roof Brace	BS2
Firestops	
Firestop	6BF
Radiation Shield	6RS
Insulated Attic Radiation Shield	6RSA2
Insulated Wall Radiation Shield	6RSM
Insulated Wall Radiation Shield, 30°	6RSMI30
Uninsulated Wall Radiation Shield, 30°	6RSM30
Attic Radiation Shield	ACRSA
Roof Flashings	
Flat Roof Flashing	6FR
1/12 - 7/12 (5° - 30°)	6FAR
8/12 - 12/12 (30° - 45°)	6FBR
Storm Collar	6FC

DuraTech DTC 1" High Temp. Insulated Stainless Steel Chimney 6" I.D. and 8" O.D., Double-Wall Stainless Steel, Listed to CAN/UCL-S604, UL-103HT and CAN/ULC S629	
Description	Part/Cat. No.
Lengths and Misc. Chimney Components	
8" length, 6" Dia.	6DTC-08SS
12" length, 6" Dia.	6DTC-12SS
18" length, 6" Dia.	6DTC-18SS
24" length, 6" Dia.	6DTC-24SS
36" length, 6" Dia.	6DTC-36SS
48" length, 6" Dia.	6DTC-48SS
Adjustable Length 12", 6" Dia.	6DTC-12TASS
15° elbow, 6" Dia.	6DTC-E15SS
30° elbow, 6" Dia.	6DTC-E30SS
Rain Termination Cap, 6" Dia.	6DTC-VC
Spark Arrester Screen (universal spark arrester band)	DTC-SA
Wall Band	DTC-WSU
Supports	
Offset Support	DTC-RESU
Roof Support	DTC-RS
Roof Brace	DTC-XRB
Firestops	
Firestop	6DTC-FS
Radiation Shield	6DTC-FRS
Insulated Attic Radiation Shield	6DTC-ISI
Insulated Wall Radiation Shield	6DTC-WTI
Insulated Wall Radiation Shield, 30°	6DTC-WRSI30
Uninsulated Wall Radiation Shield, 30°	6DTC-WRSI45
Attic Radiation Shield	6DTC-ISIA
Roof Flashings	
Flat Roof Flashing	6DTC-FF
1/12 - 7/12 (5° - 30°)	6DTC-F7
8/12 - 12/12 (30° - 45°)	6DTC-F12
Storm Collar	6DTC-SC

Fireplace Model Brentwood™ LV - Approved Venting Components manufactured by Security Chimneys® or Dura Vent only.

- **6" diameter chimney** - AC (air cooled), Secure Temp® ASHT (or Nova Temp® HT6103+) and Secure Temp S-2100+ (or Nova Temp HT6000+).
- **6" diameter chimney for relining masonry chimneys** - Tubinox® chimney (or Projet® SS), 6" diameter with adaptor for installation in a masonry chimney.
- **6" diameter chimney** - M&G DuraVent model DuraTech and DuraTech DTC.

NOTES:

- ① Nova Temp HT6000+ is equivalent to Secure Temp S-2100+
- ② DuraTech DTC and Nova Temp HT6103+ are equivalent to Secure Temp ASHT+
- ③ This appliance is equipped with the ASHT Chimney Adaptor. When other chimney is used, a chimney adaptor for that chimney will be required.
- ④ Chimney Adaptor (S-2100+ / HT6000+) for CANADA ONLY - If you want to install a S-2100+ / HT6000+ chimney, an adaptor is available (6UCA).
- ⑤ AC Chimney is NOT recommended at elevations above 4,000 feet or in cold climates (climates where temperatures will fall below 32° F / 0° C). When using AC chimney, an AC6SB starter section must be used before installing an elbow. When an offset is needed immediately off the top of the fireplace, an elbow starter section, AC6SB30, is available.

SECURITY CHIMNEYS® - PARTS AND COMPONENTS LISTS

The components listed below must be ordered from Security Chimneys®. Contact your Security Chimneys Distributor or Dealer for ordering information.

Security Chimneys®
2125 Monterey, Laval, Quebec
Canada, H7L 3T6
securitychimneys.com

450-973-9999
1-800-361-4909 (USA)
1-800-667-3387 (Canada)

(AC) Air-Cooled Chimney System*	
6" I.D. and 11" O.D. Air Cooled, Stainless Steel inner and zinc coated steel exterior	
<i>* AC Chimney is NOT recommended at elevations above 4,000 feet or in cold climates (climates where temperatures will fall below 32° F / 0° C).</i>	
Description	Cat./Part No.
One of the following adaptors is required if installing an AC chimney system	
Starter Section (adaptor), 6", AC, AC6SB	AC6SB
Starter 30° Elbow, 6" AC, AC6SB30	AC6SB30
The following outside air kit is required if installing an AC chimney system	
Chimney Outside Air Kit (flex, insulation, outside register and coupling), ACZI	ACZI
Lengths and Misc. Chimney Components	
12" Length, 6" Dia., AC6L12	AC6L12
18" Length, 6" Dia., AC6L18	AC6L18
36" Length, 6" Dia., AC6L36	AC6L36
48" Length, 6" Dia., AC6L48	AC6L48
15° Elbow, 6" Dia., AC6E15	AC6E15
30° Elbow, 6" Dia., AC6E30	AC6E30
Rain Termination Cap, 6" Dia., AC6CPR	AC6CPR
Spark Arrester Screen (universal spark arrester band), PE	PE
Wall Band, XBM	XBM
Supports	
Offset Support, SO	SO
Support Section, AC6SL	AC6SL
Roof Support, ST	ST
Roof Brace, BS2	BS2
Roof Flashings	
Flat Roof Flashing, ACF	ACF
1/12 - 7/12 (5° - 30°), AC Adj. Roof Flashing, FA	FA
8/12 - 12/12 (30° - 45°), AC Adj. Roof Flashing, FB	FB
Storm collar, ACFC	ACFC
Misc.	
Telescopic attic radiation shield, ACRST	ACRST
Firestop, ACBF	ACBF
Radiation Shield, ACRS	ACRS
Attic Radiation Shield, ACRSA	ACRSA
Insulated Wall Radiation Shield, 30°, ACRSMI30	ACRSMI30

Tubinox® LL Chimney Lining System**	
Rigid Stainless Steel Liner For Relining A Masonry Chimney, 6" Diameter <i>Listed to ULC-S635M, UL-1777 and ULC-S640M at 2100° F</i>	
Description	Cat./Part No.
6" Length, 6" Dia., 6LL6	6LL6
12" Length, 6" Dia., 6LL12	6LL12
24" Length, 6" Dia., 6LL24	6LL24
36" Length, 6" Dia., 6LL36	6LL36
48" Length, 6" Dia., 6LL48	6LL48
Adjustable Length (7" to 11"), 6" Dia., 6L7A	6L7A
Split Base Tee, 6" Dia., 6LT	6LT
Tee Cap, 6" Dia., 6TCS	6TCS
Twist Lock Tee Cap, 6" Dia., 6LTC	6LTC
Elbow 30°, 6" Dia., 6LE30	6LE30
Elbow 45°, 6" Dia., 6LE45	6LE45
Elbow 90°, 6" Dia., 6LE90	6LE90
Rain Termination Cap (regular), 6" Dia., 6LCS	6LCS
Rain Termination Cap (deluxe), 6" Dia., 6LCC	6LCC
Spark Arrester Screen (universal spark arrester band), PE	PE
Supports	
Top Support, 6LST	6LST
Support Assembly, 6LSA	6LSA
Interior Support, 6LSB	6LSB
Adaptor Flexible Pipe (male), 6LAAM	6LAAM
Adaptor Flexible Pipe (female), 6LAAF	6LAAF
Stainless Steel Flex - five (5) feet Long, 6LLFLEX	6LLFLEX
Adjustable Insulated Wall Radiation Shield 6" - 12", 6LRSMI	6LRSMI
Adaptors to Masonry Chimney	
Masonry Chimney Adaptor, 45°, BISUMA (for use with Tubinox liner) CANADA ONLY	BISUMA
Masonry Chimney Adaptor, 30°, BISUMA30 (for use with Tubinox liner)	BISUMA30

** Alternate brand rigid stainless liner or stainless flex may be substituted but must be listed to UL-1777 for US application and ULC-S635 for existing masonry or ULC-S640M for new masonry applications in Canada. The steel rigid or flex liner must be rated at 2100° F (1100° C).

Gravity Kit Accessories	
Elbow 90°, 8" dia., 7B26ZE90	7B26ZE90
Elbow 45°, 8" dia., 7B26ZE45	7B26ZE45
Telescopic length, 8" dia. (15" to 26"), 7B26ZLA	7B26ZLA
Adjustable length 8" dia (2" - 5"), 7B26ZL2A	7B26ZL2A
Wall radiation shield, 8" I.D., 7B26ZR	7B26ZR
Black grill with support, 7B30ZO	7B30ZO
Brass grill (for 7B30ZK), 7B30ZGB	7B30ZGB
Length one (1) feet, 8KL1	8KL1
Length two (2) feet, 8KL2	8KL2
Length three (3) feet, 8KL3	8KL3
Length four (4) feet, 8KL4	8KL4
Length five (5) feet, 8KL5	8KL5



Report No. / Rapport n°
14-180

LISTED FACTORY BUILT FIREPLACE
FOYER PRÉFABRIQUE HOMOLOGUÉ

FIREPLACE, ALSO FOR USE IN MANUFACTURED

HOMES WITH SOLID FUEL ONLY

CE FOYER EST ÉGALEMENT CERTIFIÉ POUR

INSTALLATION DANS LES MAISONS MOBILES

COMBUSTIBLES SOLIDES SEULEMENT.

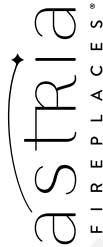

Manufactured by / Fabriqué par:
INNOVATIVE HEARTH PRODUCTS

1502 14th St. NW
Auburn, WA 98001 USA

Serial No.
Numéro de série

Model / Modèle: Brentwood™ LV

Conforms to / Conforme au : UL STD 127
Certified to / Certifié au : ULC STD S610

Certification test emission value 3.7 g/hr per 2015 standard

Valeur d'émission du test d'homologation 3.7 g/h selon la norme 2015

CLEARANCES TO COMBUSTIBLES:

SIDE WALL (FROM DOOR EDGE) 24 in. (610 mm)
MANTEL (ABOVE FIREPLACE'S BASE) 45 in. (1372 mm)
BACK WALL (FROM SPACERS) 0 in. (0 mm)
THE BASE OF THE FIREPLACE) 6 ft. 8 in. (2032 mm)
CHIMNEY 2 in. (51 mm)

DÉGAGEMENTS AUX COMBUSTIBLES:

MUR LATÉRAL (DE L'OUVERTURE DE LA PORTE) 24 po. (610 mm)
LINTEAU (AU-DESSUS DE LA BASE DU FOYER) 45 po. (1372 mm)
MUR ARRIÈRE ET CÔTÉ DU FOYER (DES ESPACEURS) 0 po. (0 mm)
AU-DESSUS DU FOYER (A PARTIR DE LA BASE DU FOYER) 6 pi. 8 po. (2032 mm)
CHEMINÉE 2 po. (51 mm)

INSTALL WITH MINIMUM CLEARANCES TO WALL
AS SHOWN IN INCHES.

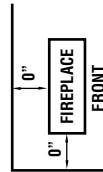

SIDEWALL - BACKWALL
INSTALLATION

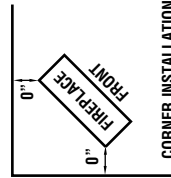

CORNER INSTALLATION

FLOOR PROTECTOR MINIMUM DISTANCE
FROM OPENING IN INCHES

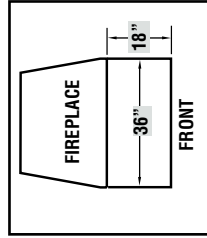

HEARTH EXTENSION MATERIAL:
- 3/8" THICKNESS NON COMBUSTIBLE
MATERIAL
- OR EQUIVALENT

U.S. ENVIRONMENTAL PROTECTION AGENCY

Certified to comply with 2015 particulate emission standards.

Not approved for sale after May 15, 2020.

DATE OF MFG. 1 2 3 4 5 6 7 8 9 10 11 12

2018-19-20-21-22-23-24

P/N 900438-00, REV. 0, 05/2015

- USE WOOD FUEL ONLY
- NON COMBUSTIBLE HEARTH EXTENSION MUST BE INSTALLED AT FRONT OF UNIT EXTENDING 18 in. (457 mm) AT FRONT AND 36 in. (914 mm) WIDE MINIMUM.
- THIS FIREPLACE HAS NOT BEEN TESTED WITH UNVENTED GAS LOG SET. TO REDUCE RISK OF FIRE OR INJURY DO NOT INSTALL AN UNVENTED GAS LOG SET INTO THE FIREPLACE.
- ELECTRICAL RATING: 120 V, 60 Hz
- CHIMNEY TYPE: USE ONLY WITH LISTED 6 in. DIAMETER CHIMNEY, CERTIFIED MODEL ASHT+, S-2100+, HT6000+, HT6103+ OR AC.
- CAN BE CONNECTED TO A MASONRY CHIMNEY AS DESCRIBED IN THE INSTALLATION INSTRUCTIONS.
- COMPONENTS USED WITH THE FIREPLACE MUST BE LISTED. SEE LIST IN THE INSTALLATION INSTRUCTIONS.
- REPLACE GLASS WITH CERAMIC GLASS 5 mm THICK.
- FOR SAFE OPERATION INSTALL IN ACCORDANCE WITH THE MANUFACTURER'S INSTRUCTIONS.
- CAUTION: COMBUSTION AIR OPENING MUST NOT BE OBSTRUCTED.
- DO NOT OVERFIRE THE FIREPLACE.
- OPERATE THE FIREPLACE WITH DOOR FULLY OPEN OR FULLY CLOSED ONLY.
- DO NOT USE A FIREPLACE INSERT OR OTHER PRODUCTS NOT SPECIFIED FOR USE WITH THIS PRODUCT
- CONTACT YOUR LOCAL BUILDING OR FIRE OFFICIALS ABOUT RESTRICTIONS AND INSTALLATION INSPECTIONS IN YOUR AREA.
- CONTACTEZ LES RESPONSABLES DE VOTRE REGION A PROPOS DES RESTRICTIONS ET INSPECTIONS D'INSTALLATION.
- SEE IHP INSTALLATION AND OPERATING INSTRUCTIONS FOR THIS MODEL.
- INSTALL AND USE ONLY IN ACCORDANCE WITH THE MANUFACTURER'S INSTRUCTIONS AND LOCAL BUILDING CODES.
- SPECIAL METHODS ARE REQUIRED WHEN PASSING THROUGH A WALL OR CEILING. SEE INSTRUCTIONS AND BUILDING CODES.
- PREVENT CREOSOTE FIRE: INSPECT CHIMNEY CONNECTOR AND CHIMNEY FLUE MONTHLY AND CLEAN IF NECESSARY.
- DO NOT OVERFIRE. IF DOME OR CHIMNEY CONNECTOR GLOWS YOU ARE OVERFIRING.
- KEEP FURNISHINGS AND OTHER COMBUSTIBLE MATERIALS A CONSIDERABLE DISTANCE AWAY FROM APPLIANCE.
- MAINTENIR LES MEUBLES ET AUTRES OBJETS À UNE DISTANCE SÉCURITAIRE DU FOYER.
- THIS WOOD HEATER NEEDS PERIODIC INSPECTION AND REPAIR FOR PROPER OPERATION. CONSULT THE OWNER'S MANUAL FOR FURTHER INFORMATION. IT IS AGAINST FEDERAL REGULATIONS TO OPERATE THIS WOOD HEATER IN A MANNER INCONSISTENT WITH THE OPERATING INSTRUCTIONS IN THE OWNER'S MANUAL.
- GET APPAREIL DE CHAUFFAGE AU BOIS DOIT ÊTRE INSPECTÉ ET ENTRETENU PÉRIODIQUEMENT POUR FONCTIONNER CORRECTEMENT. VOIR LE MANUEL DU PROPRIÉTAIRE POUR PLUS D'INFORMATION. L'UTILISATION DE CET APPAREIL DE CHAUFFAGE AU BOIS DE MANIÈRE INCOMPATIBLE AVEC LES INSTRUCTIONS DU MANUEL DU PROPRIÉTAIRE CONSTITUE UNE INFRACTION AUX RÉGULATIONS FÉDÉRALES.
- POUR USAGE AVEC LE BOIS SEULEMENT
- UN TABLIER NON COMBUSTIBLE DOIT ÊTRE INSTALLÉ À L'AVANT DU FOYER. DIMENSION MINIMALE DE 18 po. (457 mm) PAR 36 po. (914 mm) DE LARGE.
- CE FOYER N'EST PAS HOMOLOGUÉ POUR ÊTRE UTILISÉ AVEC UN ENSEMBLE DE BûCHES À GAZ SANS CONDUIT D'ÉVACUATION. AFIN DE RÉDUIRE LES RISQUES D'INCENDIE OU DE BLESSURES, N'INSTALLEZ PAS DE BûCHES À GAZ SANS CONDUIT D'ÉVACUATION À L'INTÉRIEUR DE CE FOYER.
- ALIMENTATION ÉLECTRIQUE: 120V, 60 Hz
- UTILISER SEULEMENT AVEC UNE CHEMINÉE 6 po. (150 mm) DE DIAMÈTRE, MODÈLE ASHT+, S2100+, HT6000+, HT6103+ OU AC HOMOLOGUÉE
- PEUT ÊTRE RACCORDÉ SUR UNE CHEMINÉE DE MAÇONNERIE TEL QUE DÉCRIT DANS LE MANUEL D'INSTALLATION.
- LES COMPOSANTES UTILISÉES AVEC LE FOYER DOIVENT ÊTRE HOMOLOGUÉES. VOIR LA LISTE DANS LE MANUEL D'INSTALLATION.
- REMPLACER LA VITRE AVEC UN VERRE CÉRAMIQUE DE 5mm D'ÉPAISSEUR.
- POUR UNE UTILISATION SÉCURITAIRE, INSTALLER CONFORMÉMENT AUX DIRECTIVES DU FABRICANT.
- ATTENTION: NE PAS OBSTRUER LES ARRIVÉES D'AIR COMBURANT.
- NE PAS FAIRE SURCHAUFFER LE FOYER.
- LA PORTE DU FOYER DOIT DEMEURER TOTALEMENT OUVERTE OU TOTALEMENT FERMÉE LORSQUE LE FOYER FONCTIONNE.
- NE PAS UTILISER DE POÈLE ENCASTRABLE OU D'AUTRES PRODUITS NON SPÉCIFIÉS COMME ÉTANT UTILISABLES AVEC CE PRODUIT.
- CONTACTEZ VOS OFFICIAUX LOCAUX EN MATIÈRE D'INSTALLATION ET D'INSPECTIONS DANS VOTRE RÉGION.
- VOIR LES INSTRUCTIONS D'INSTALLATION ET D'UTILISATION DE CE PRODUIT.
- INSTALLER ET UTILISER SEULEMENT EN ACCORDANCE AVEC LES INSTRUCTIONS ET LES CODES LOCAUX DE CONSTRUCTION.
- MÉTHODES SPÉCIALES SONT REQUISES POUR LE PASSAGE À TRAVERS UN MUR OU UN PLAFOND. VOIR LES INSTRUCTIONS ET LES CODES DE CONSTRUCTION.
- PRÉVENIR LES INCENDIES PAR CRÉOSOTE: INSPECTER LE CONNECTEUR DE LA CHIMÉE ET LA CHIMÉE ELLE-MÊME MOIS ET NETTOYER SI BESOIN.
- NE PAS SURCHAUFFER LE FOYER.
- LE CHAUFFAGE À BOIS DOIT ÊTRE INSPECTÉ ET ENTRETENU PÉRIODIQUEMENT.
- CE CHAUFFAGE À BOIS NE DOIT PAS ÊTRE UTILISÉ D'UNE MANIÈRE INCOMPATIBLE AVEC LES INSTRUCTIONS DU MANUEL DU PROPRIÉTAIRE.

NOTES

Mountain View Hearth Products
manuals.stove-parts-unlimited.com

Innovative Hearth Products Astria® Brand EPA Wood Burning Fireplace Limited Lifetime Warranty

THE WARRANTY

Innovative Hearth Products ("IHP") Limited Lifetime Warranty warrants your Astria® Brand EPA Wood Burning Fireplace ("Product") to be free from defects in materials and workmanship at the time of manufacture. The Product body, firebox and ceramic glass carry the Limited Lifetime Warranty. Ceramic glass carries the Limited Lifetime Warranty against thermal breakage only. After installation, if covered components manufactured by IHP are found to be defective in materials or workmanship during the Limited Lifetime Warranty period and while the Product remains at the site of the original installation, IHP will, at its option, repair or replace the covered components. If repair or replacement is not commercially practical, IHP will, at its option, refund the purchase price or wholesale price of the IHP product, whichever is applicable. IHP will also pay IHP prevailing labor rates, as determined in its sole discretion, incurred in repairing or replacing such components for up to five years. THERE ARE EXCLUSIONS AND LIMITATIONS to this Limited Lifetime Warranty as described herein.

COVERAGE COMMENCEMENT DATE

Warranty coverage begins on the date of purchase. In the case of new home construction, warranty coverage begins on the date of first occupancy of the dwelling or six months after the sale of the Product by an independent IHP dealer/distributor, whichever occurs earlier. The warranty shall commence no later than 24 months following the date of product shipment from IHP, regardless of the installation or occupancy date.

EXCLUSIONS AND LIMITATIONS

This Limited Lifetime Warranty applies only if the Product is installed in the United States or Canada and only if operated and maintained in accordance with the printed instructions accompanying the Product and in compliance with all applicable installation and building codes and good trade practices.

This warranty is non-transferable and extends to the original owner only. The Product must be purchased through a listed supplier of IHP and proof of purchase must be provided. The Product body and firebox carry the Limited Lifetime Warranty from the date of installation. Vent components, trim components and paint are excluded from this Limited Lifetime Warranty. The following do not carry a Limited Lifetime Warranty but are warranted as follows:

Cast Iron Heat Exchanger – Replacement for five years from the date of installation

Cast iron parts – Replacement for one year from the date of installation

Catalyst – Carries a separate warranty. Refer to the warranty certificate provided for that part

Electrical components – Repair or replacement for one year from date of installation

Gaskets – Replacement for one year from the date of installation.

Gold & nickel plating – Replacement for two years from date of installation. Excludes tarnishing

Refractory & screens – Replacement for two years from date of installation. Excludes hairline cracks

Removable air tubes – Repair or replacement for seven years from date of installation. IHP prevailing labor rates for years one through five.

Labor coverage – Prevailing IHP labor rates apply for the warranty period of the component, unless otherwise noted

Parts not otherwise listed carry a 90 day warranty from the date of installation.

Whenever practicable, IHP will provide replacement parts, if available, for a period of 10 years from the last date of manufacture of the Product.

IHP will not be responsible for: (a) damages caused by normal wear and tear, accident, riot, fire, flood or acts of God; (b) damages caused by abuse, negligence, misuse, or unauthorized alteration or repair of the Product affecting its stability or performance. (The Product must be subject to normal use with approved fuels listed in the Operation Manual provided with the product. Fuel products with abnormal burning characteristics, including but not limited to fuel such as driftwood, coal or plywood and wood products using a binder may burn at excessive temperatures and may cause damage to the Product or may cause it to function improperly; IHP stoves, inserts and high efficiency EPA fireplaces are approved for burning dry seasoned wood only.); (c) damages caused by failing to provide proper maintenance and service in accordance with the instructions provided with the Product; (d) damages, repairs or inefficiency resulting from faulty installation or application of the Product.

Coverage of this Limited Lifetime Warranty is conditional upon the appliance being operated without the use of grates, irons or any other method to elevate the fire.

IHP is not responsible for inadequate system draft caused by air conditioning and heating systems, mechanical ventilation systems, or general construction conditions which may generate negative air pressure in the room in which the appliance is installed. Additionally IHP assumes no responsibility for smoking conditions caused by inadequate chimney height, adjoining trees or buildings, adverse wind conditions or unusual environmental factors and conditions. Certain IHP Products are listed for use with Security Chimneys International, Ltd. chimney systems only. Use of chimney components other than that specified in the Product manual will void the Product warranty.

This Limited Lifetime Warranty covers only parts and labor as provided herein. In no case shall IHP be responsible for materials, components or construction which are not manufactured or supplied by IHP or for the labor necessary to install, repair or remove such materials, components or construction. Additional utility bills incurred due to any malfunction or defect in equipment are not covered by this Limited Lifetime Warranty. All replacement or repair components will be shipped F.O.B. from the nearest stocking IHP factory.

LIMITATION ON LIABILITY

It is expressly agreed and understood that IHP's sole obligation and the purchaser's exclusive remedy under this warranty, under any other warranty, expressed or implied, or in contract, tort or otherwise, shall be limited to replacement, repair, or refund, as specified herein.

In no event shall IHP be liable for any incidental or consequential damages caused by defects in the Product, whether such damage occurs or is discovered before or after replacement or repair, and whether such damage is caused by IHP's negligence. IHP has not made and does not make any representation or warranty of fitness for a particular use or purpose, and there is no implied condition of fitness for a particular use or purpose.

IHP makes no expressed warranties except as stated in this Limited Lifetime Warranty. The duration of any implied warranty is limited to the duration of this expressed warranty.

No one is authorized to change this Limited Lifetime Warranty or to create for IHP any other obligation or liability in connection with the Product. Some states and provinces do not allow the exclusion or limitation of incidental or consequential damages, so the above limitations or exclusions may not apply to you. The provisions of this Limited Lifetime Warranty are in addition to and not a modification of or subtraction from any statutory warranties and other rights and remedies provided by law.

INVESTIGATION OF CLAIMS AGAINST WARRANTY

IHP reserves the right to investigate any and all claims against this Limited Lifetime Warranty and to decide, in its sole discretion, upon the method of settlement.

To receive the benefits and advantages described in this Limited Lifetime Warranty, the appliance must be installed and repaired by a licensed contractor approved by IHP.

Contact IHP at the address provided herein to obtain a listing of approved dealers/distributors. **IHP shall in no event be responsible for any warranty work done by a contractor that is not approved without first obtaining IHP's prior written consent.**

HOW TO REGISTER A CLAIM AGAINST WARRANTY

In order for any claim under this warranty to be valid, you must contact the IHP dealer/distributor from which you purchased the product. If you cannot locate the dealer/distributor, then you must notify IHP in writing. IHP must be notified of the claimed defect in writing within 90 days of the date of failure. Notices should be directed to the IHP Warranty Department at 1769 East Lawrence Street; Russellville, AL 35654 or visit our website at WWW.ASTRIA.US.COM.

WARRANTY

Your fireplace is covered by a limited warranty. Please read the warranty to be familiar with its coverage.

Retain this manual. File it with your other documents for future reference.

PRODUCT REFERENCE INFORMATION

We recommend that you record the following important information about your fireplace. Please contact your IHP dealer for any questions or concerns.

REPLACEMENT PARTS

See **Page 25** for a complete replacement parts list. Use only parts supplied from the manufacturer.

Normally, all parts should be ordered through your IHP distributor or dealer. Parts will be shipped at prevailing prices at time of order.

When ordering repair parts, always give the following information:

1. The model number of the appliance.
2. The serial number of the appliance.
3. The part number.
4. The description of the part.
5. The quantity required.
6. The installation date of the appliance.

If you encounter any problems or have any questions concerning the installation or application of this system, please contact your dealer.

IHP
1769 East Lawrence Street
Russellville, AL 35654
Visit us at Astria.us.com

Model Number _____
Serial Number _____
Date Installed _____
Dealer's Name _____
Dealer's Phone Number _____

NATIONAL FIREPLACE INSTITUTE
NFI
CERTIFIED
www.nficertified.org

We recommend that our woodburning hearth products be installed and serviced by professionals who are certified in the U.S. by the National Fireplace Institute® (NFI) as NFI Woodburning Specialists or who are certified in Canada by Wood Energy Technical Training (WETT).

Wood Energy Technical Training
www.wettinc.ca

IHP reserves the right to make changes at any time, without notice, in design, materials, specifications, and prices, and also to discontinue colors, styles, and products. Consult your local distributor for fireplace code information.

