

# Blaze King

## ASHFORD 25(AF25)

SOLID FUEL WOOD CATALYTIC STOVE

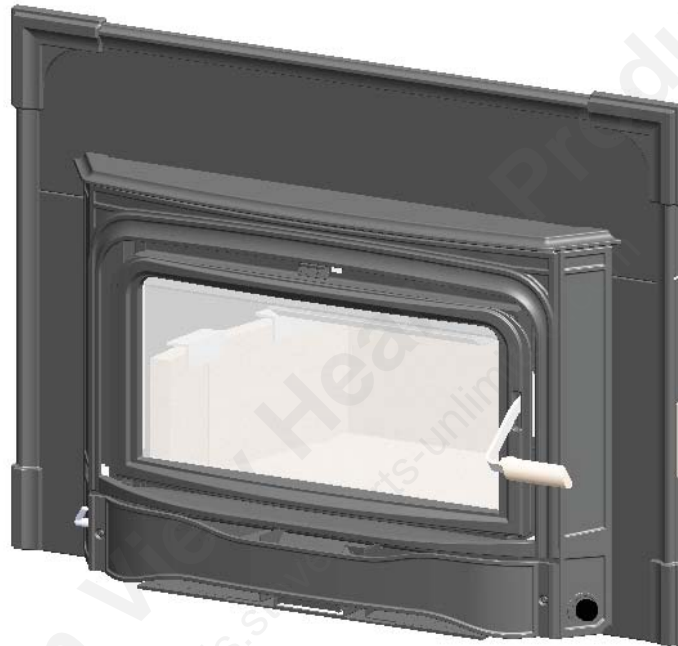

This heater meets the 2015 U.S. Environmental Protection Agency's particulate emission limits for wood heaters sold after May 15, 2015.



**Installer: Please complete the details on the back cover and leave this manual with the homeowner.**  
**Homeowner: Please SAVE THESE INSTRUCTIONS for future reference.**

The authority having jurisdiction (such a municipal building department, fire department, etc.) should be consulted before installation to determine the need to obtain a permit.

## OPERATION & INSTALLATION MANUAL

**Manufactured By**

**Valley Comfort Systems Inc.**, 1290 Commercial Way, Penticton, BC, V2A 3H5, Canada  
Phone: 250-493-7444 ♦ Fax: 250-493-5833 ♦ [www.blazeking.com](http://www.blazeking.com) ♦ [info@blazeking.com](mailto:info@blazeking.com)

Pour la version française de nos manuels S.V.P. vous référez à notre site web: [www.blazeking.com](http://www.blazeking.com)

<b>INTRODUCTION</b>	4
<b>SPECIFICATIONS</b>	5
<b>EMISSIONS</b>	5
<b>APPLIANCE DIMENSIONS for AF25</b>	6
<i>DIMENSIONS—#Z2091 Regular Shroud</i>	6
<i>Electrical Diagram—Ashford 25</i>	6
<i>DIMENSIONS—#Z2093 Large Shroud</i>	6
<b>CERTIFICATION LABEL</b>	7
<b>LABEL LOCATION</b>	7
<b>SAFETY PRECAUTIONS</b>	8
<b>INSTALLATION INSTRUCTIONS</b>	11
<i>FLOOR PROTECTION</i>	11
<i>COMPONENTS REQUIRED</i>	11
<i>PARTS INCLUDED WITH THE ASFORD INSERT</i>	11
<i>REQUIRED SHROUD OPTIONS</i>	11
<i>MINIMUM CLEARANCES for AF25</i>	12
<i>COMBUSTION AIR</i>	13
<i>DRAFTING PERFORMANCE</i>	13
<i>ROLE OF THE CHIMNEY</i>	13
<i>INSPECT CHIMNEY</i>	14
<i>PLANNING STOVE PLACEMENT</i>	14
<i>FRONT CAST REMOVAL</i>	15
<i>STOVE ASSEMBLY</i>	15
<i>Bypass door wedge removal</i>	15
<i>CHIMNEY</i>	19
<b>OPERATING INSTRUCTIONS</b>	20
<i>YOUR FIRST FIRE!</i>	20
<i>THERMOSTAT</i>	20
<i>BYPASS</i>	20
<i>CATALYTIC THERMOMETER</i>	21
<i>SELECTING WOOD</i>	21
<i>HOW TO USE MOISTURE METERS</i>	22
<i>EFFICIENCY</i>	22
<i>LIGHTING THE FIRE</i>	23
<i>RELOADING PROCEDURE (with the catalyst temperature in the active red zone)</i>	24
<i>RELOADING PROCEDURE (with the catalyst temperature still in the inactive zone)</i>	24
<i>OPTIMAL THERMOSTAT SETTING</i>	25
<i>FAN OPERATION</i>	25
<i>ICE - FORMATION AND PREVENTION</i>	25
<i>WOOD BURNING IN THE SHOULDER SEASON</i>	26
<b>CATALYST MONITORING</b>	27
<i>CATALYTIC COMBUSTOR, TESTING</i>	27
<i>CATALYTIC COMBUSTOR, CLEANING</i>	27
<i>CATALYTIC COMBUSTOR, TROUBLESHOOTING</i>	28
<i>CATALYTIC COMBUSTOR, REPLACEMENT</i>	30

<b>MAINTENANCE</b>	<b>33</b>
<i>RUN-AWAY OR CHIMNEY FIRE</i>	33
<i>CREOSOTE FORMATION AND REMOVAL</i>	33
<i>ASH REMOVAL</i>	34
<i>CHIMNEY MAINTENANCE</i>	34
<i>FIRE EXTINGUISHERS AND SMOKE DETECTORS</i>	34
<i>LOADING DOOR GASKET INSPECTION</i>	35
<i>LOADING DOOR GASKET REPLACEMENT</i>	35
<i>BYPASS DOOR GASKET RETAINER REPLACEMENT #Z2022</i>	36
<i>DOOR GLASS GASKET INSPECTION</i>	38
<i>DOOR GLASS GASKET REPLACEMENT</i>	38
<i>DOOR GLASS, REPLACEMENT</i>	38
<i>DOOR GLASS, CLEANING</i>	38
<i>LOADING DOOR TENSION ADJUSTMENT</i>	39
<i>LOADING DOOR HINGE ADJUSTMENT</i>	39
<i>FAN ASSEMBLY</i>	40
<i>THERMOSTAT</i>	40
<b>TROUBLESHOOTING</b>	<b>41</b>
<b>REPLACEMENT PARTS</b>	<b>44</b>
<b>WARRANTY</b>	<b>47</b>
<b>INSTALLER NOTES</b>	<b>52</b>

## ⚠ WARNING

- **THIS APPLIANCE IS HOT WHEN OPERATED AND CAN CAUSE SEVERE BURNS IF CONTACTED.**
- **ANY CHANGES OR ALTERATIONS TO THIS APPLIANCE OR ITS CONTROLS CAN BE DANGEROUS AND IS PROHIBITED BY FEDERAL AND STATE LAWS.**
- Do not operate appliance before reading and understanding operating instructions. Failure to operate appliance according to operating instructions could cause fire or injury.
- Before installing this appliance, contact the local building or fire authority and follow their guidelines.
- This appliance must be installed by a qualified installer.
- Risk of burns. The appliance should be turned off and cooled before servicing.
- Do not operate without fully assembling all components.
- Do not let the appliance become hot enough for any part to glow red.
- Do not install damaged, incomplete or substitute components.
- Risk of cuts and abrasions. Wear protective gloves and safety glasses during installation. Sheet metal edges may be sharp.
- Children and adults should be alerted to the hazards of high surface temperature and should stay away to avoid burns or clothing ignition.
- Young children should be carefully supervised when they are in the same room as the appliance. Toddlers, young children and others may be susceptible to accidental contact burns. A physical barrier is recommended if there are at risk individuals in the house. To restrict access to an appliance or appliance, install an adjustable safety gate to keep toddlers, young children and other at risk individuals out of the room and away from hot surfaces.
- Clothing or other flammable material should not be placed on or near the appliance. Objects placed in front of the appliance must be kept a minimum of 48" away from the front face of the appliance.
- Due to high temperatures, the appliance should be located out of traffic and away from furniture and draperies.
- Ensure you have incorporated adequate safety measure to protect infants / toddlers from touching hot surfaces.
- Even after the appliance is out, all surfaces, including the glass and/or any attachment will remain hot for an extended period of time.
- Check with your local hearth specialty dealer for safety hearth guards to protect children from hot surfaces. These guards must be fastened to a wall and/or to the floor.
- Any safety guard removed for servicing must be replaced prior to operating the appliance.
- Under no circumstances should this appliance be modified.
- This appliance must not be connected to a chimney flue pipe servicing a separate solid fuel burning appliance.
- Do not operate the appliance with the glass door removed, cracked or broken. Replacement of the glass should be done by a licensed or qualified service person.
- Do not strike or slam shut the appliance glass door.
- Operate only with the doors tightly closed.
- Appliance will over-fire if door is not shut and latched.
- Only certified doors / optional fronts / and surrounds for inserts with the unit are to be installed on the appliance.
- Keep the packaging material out of reach of children and dispose of the material in a safe manner. As with all plastic bags, these are not toys and should be kept away from children and infants.
- If the appliance is not properly installed, a house fire may result. Do not expose the appliance to the elements (ex. rain, etc.) and keep the appliance dry at all times.
- The chimney must be sound and free of cracks and obstructions. Clean your chimney regularly as required.
- Never use gasoline, gasoline-type lantern fuel, kerosene, charcoal lighter fluid, or similar liquids to start or 'freshen up' a fire in this heater. Keep all such liquids well away from the heater while it is in use.
- Your appliance requires periodic maintenance and cleaning. Failure to maintain your appliance may lead to smoke spillage in your home.
- Higher efficiencies and lower emissions will generally result when burning air dried seasoned woods, as compared to wet, green or freshly cut wood. Burning wet unseasoned wood can cause excessive creosote accumulation. When ignited it can cause a chimney fire that may result in a serious house fire.
- The appliance is designed to burn seasoned wood only. Do not burn treated wood, coal, charcoal, colored paper, cardboard, solvents or garbage.
- Burn wood directly on the firebricks. Do not use a grate or elevate the fire.
- Do not store wood within appliance installation clearances or within the space required for re-fueling and ash removal.
- Ashes must be disposed in a metal container with a tight lid and placed on a non-combustible surface well away from the home or structure until completely cool.

Model	Ashford 25 (AF25) (catalytic)
Height and width without shroud	24 1/8" x 35 3/8" (613 mm x 899 mm)
Width of firebox enclosure (behind shroud)	27 7/8" (708 mm)
Overall depth and height of firebox	18 3/8" x 21 5/8" (639 mm x 588 mm)v
Flue collar size and distance from shroud back	6" I.D., 14 3/8" (366 mm)
Fire door opening	25 1/4" x 10 5/8" (642 mm x 270 mm)
Firebox depth	16 3/4" (426 mm) brick to brick, 18" (457 mm) brick to glass
Firebox width average	20 1/2" (521 mm)
Firebox height	10" (254 mm)
Fire box capacity	2.3 cu. ft.
Recommended Fuel length	16" max. (407 mm)
Wood capacity (approximate):	White oak - 53 lbs. (24.04 kg)
	Fir - 35 lbs. (15.88 kg)
Construction	10 gauge & 1/4" firebox, refractory brick lined. Cast iron outer shell.
Shipping Weight (Firebox only)	415 lbs. (189 kg)
Chimney recommendation (Minimum)	15' from stove top to chimney cap: Insulated liner recommended
Minimum fireplace opening	29"L x 22"H x 19P" (737 mm x 559 mm x 483 mm)

This unit was tested and listed UL 1482, Ed 7 2011 and ULC S628-93 by OMNI-Test Laboratories.

This manual describes the installation and operation of the Ashford AF25 catalytic equipped wood heater.

This heater is certified to comply with the 2015 U.S. Environmental Protection Agency's particulate emission limits for wood heaters sold after May 15, 2015.

Under specific test conditions this heater has been shown to deliver heat at rates ranging from 10097 to 26290 Btu/hr. This wood heater has a manufacturer-set minimum low burn rate that must not be altered. It is against federal regulations to alter this setting or otherwise operate this wood heater in a manner inconsistent with operating instructions in this manual.

This wood heater contains a catalytic combustor, which needs periodic inspection and replacement for proper operation. It is against federal regulations to operate this wood heater in a manner inconsistent with operating instructions in this manual, or if the catalytic element is deactivated or removed.

The combustor supplied with this heater is a 115.0335 metal combustor. Consult the catalytic combustor warranty also supplied with this wood heater. Warranty claims should be addressed to:

in Canada	in USA
Blaze King Industries / Valley Comfort Systems Warranty Department, 1290 Commercial Way Penticton, BC Canada V2A 3H5, Ph: 250-493-7444	Blaze King Industries Warranty Department, 146A Street Walla, Walla, Washington 99362, Ph: 509-522-2730

# APPLIANCE DIMENSIONS for AF25

**DIMENSIONS—#Z2091 Regular Shroud**

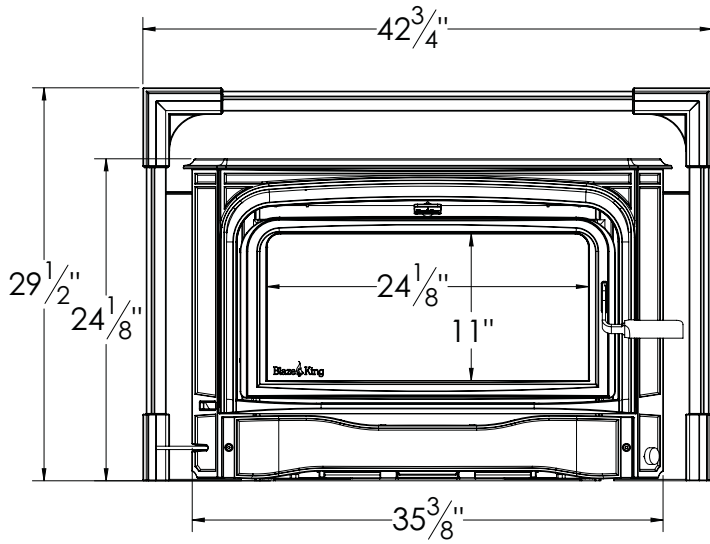

**DIMENSIONS—#Z2093 Large Shroud**

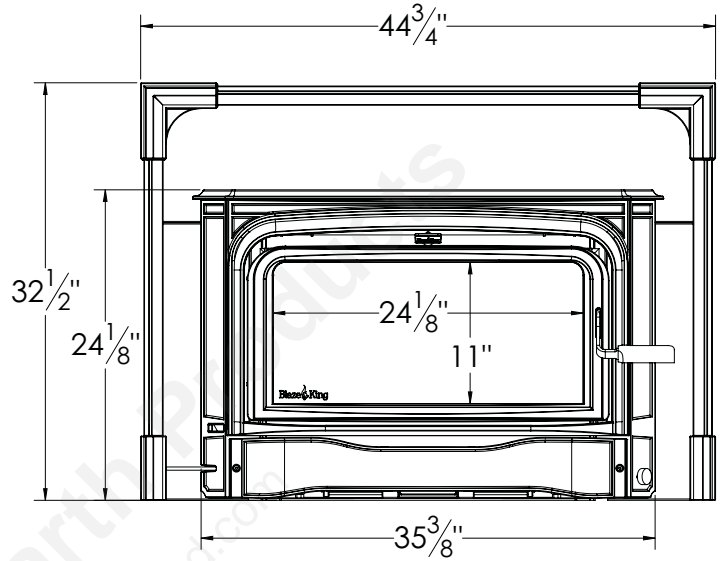

**Electrical Diagram—Ashford 25**

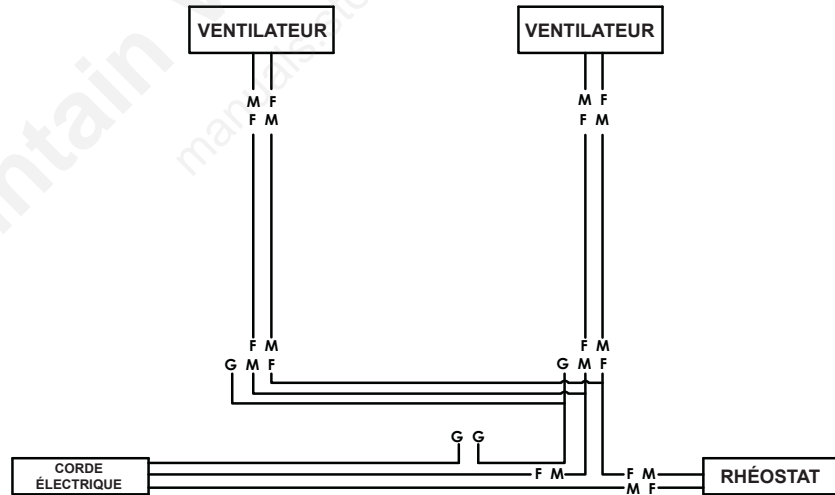

SN - 17



**ASHFORD INSERT - Encastrable Ashford**  
**BLAZE KING CATALYST STOVE - BLAZE KING ENCASTRABLE CATALYTIQUE**  
 Room heater, solid fuel type. / Appareil de chauffage approuvé pour type de carburant solide.  
 MODEL / MODÈLE: AF25  
 Tested to / Testé pour: UL 1482, Ed 7 2011 / ULC S628-93  
 CERTIFIED IN BOTH UNITED STATES AND CANADA / CERTIFIÉ POUR LES ÉTATS-UNIS ET LE CANADA

**PREVENT HOUSE FIRES** - Install and use only in accordance with Blaze King's installation and operation instructions. Install and use in a code complying fireplace only. Contact local building or fire officials about restrictions and installation inspection in your area. Do not remove bricks or mortar in masonry fireplace. Do not use grate or elevate fire. Inspect and clean chimney frequently - under certain conditions of use, creosote buildup may occur rapidly. CHIMNEYS: Do not connect this unit to a chimney flue serving another appliance. Do not over fire - if heater or chimney glows, you are over firing. **COMPONENTS REQUIRED FOR INSTALLATION:** 6" stainless steel liner - listed to: UL 1777, ULCS635 OR ULCS640, and part #225.2054 flue extension.

**PRÉVENTION DES INCENDIES**- Installer et utiliser cet appareil conformément aux instructions d'installation et du mode de fonctionnement de Blaze King. Installer et utiliser seulement selon le code conforme, concernant les foyers. Contacter le code du bâtiment local ou le département des incendies à propos des restrictions et des inspections des installations de votre région. Ne pas retirer les briques ou le mortier dans votre foyer de maçonnerie. Ne pas utiliser de grille et ne pas surélever le feu. Inspecter et nettoyer votre cheminée fréquemment- dans certaines conditions d'utilisation, une accumulation de crésote peut se produire rapidement. Cheminées : Ne pas raccorder cet appareil à un conduit de cheminée desservant un autre appareil. Ne pas surchauffer- si l'appareil ou les conduits deviennent rougeoyants, vous êtes en surchauffe. Composantes requises pour l'installation : Gaine de 6po en acier inoxydable inscrite sous : UL 1777, ULCS635 Ou ULCS640, et pièce #225.2054 extension de conduit.

Minimum clearances to combustibles, measured from firebox door flange / Dégagements minimum requis entre l'appareil à tout matériau combustible à partir du rebord de l'ouverture de porte de la chambre à combustion.	
A	Side of door flange to combustible wall. / Du côté du rebord de l'ouverture de porte à tout mur combustible. 13.5" / 343 mm
B	Top of door flange to bottom of mantel and combustible facing. (with mantle shield.) / Du dessus du rebord de l'ouverture de porte au bas du manteau et de toute façade combustible. (avec manteau avec protection) 38" / 966 mm (24" / 610 mm)
C	Side of door flange to side combustible facing. / Du côté du rebord de l'ouverture de la porte à toute surface de côté combustible. 10" / 254 mm
D	Mantle width maximum. (with mantle shield part #2098) / Largeur maximum du manteau. (avec protection de manteau pièce #2098) 12" / 305 mm (8" / 204 mm)
E	Minimum hearth side extension * / Extension latérale minimum du foyer 8"
F	Minimum hearth front extension / Extension frontale minimum du foyer 16" USA / 18" CANADA

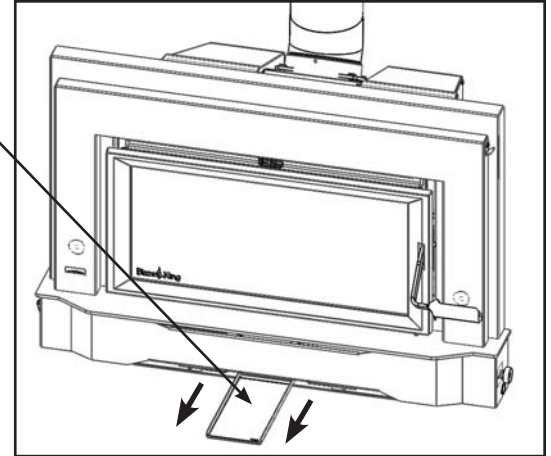
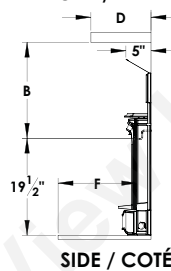
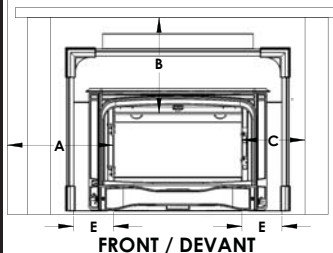

**LABEL LOCATION**

\* Measured from each side of the fuel loading and ash removal openings / Mesuré à partir de chaque côté de l'ouverture de la porte de chargement et du tiroir de cendre

**FLOOR PROTECTION / PROTECTION DU PLANCHER:**

If the bottom of the appliance is 5" (125 mm) or more above the floor level (combustible material) only ember protection is required (UL 1618 type 1) extending 16" (407 mm) in USA or 18" (458 mm) in Canada in front of the door and extending 8" to either side of the door opening. If the bottom of the appliance is at floor level (combustible material) or less than 5" (125 mm) above floor level, a layer of non-combustible thermal protection (UL 1618 type 2, where R=1.06 minimum) is required under the appliance extending 16" (407 mm) in the USA and 18" (458 mm) in Canada.

Si le fond de l'appareil est de 5" (125 mm) et plus au-dessus du niveau du sol (des matières combustibles), uniquement une protection de plancher résistant aux braises sera nécessaire (UL 1618 de type 1), une extension 16" (407 mm) aux USA ou de 18" (458 mm) au Canada devant de la porte et une extension de 8" de part et d'autre de l'ouverture de la porte. Si le fond de l'appareil est au niveau du sol ou moins de 5" (125 mm) au-dessus du niveau du sol (des matières combustibles), une couche de protection thermique non combustible (UL 1618 de type 2, où R = 1,06 min.) sera nécessaire sous l'appareil s'étendant de 16" (407 mm) aux États-Unis et de 18" (458 mm) au Canada.

Electrical rating: (115 VAC, 60 Hz, 0.58 Amps. Risk of electrical shock. Disconnect power before servicing unit. Do not route power cord in front of or beneath heater).

U.S. ENVIRONMENTAL PROTECTION AGENCY - 2015 Standard - certified to comply with 2015 particulate emission standards (EPA test methods 28R and 5G with an emission-rate of 0.90 g/hr). Not approved for sale after May 15, 2020. This wood heater needs periodic inspection and repair for proper operation. Consult the owner's manual for further information.

It is against federal regulations to operate this wood heater in a manner inconsistent with the operating instructions in the owner's manual, or if the catalytic element is deactivated or removed. Only operate with doors closed. Open door to feed fire ONLY. Open the bypass before opening the door. Do not obstruct combustion air openings. For Use With Solid Wood Fuel Only - Do not burn other fuels, this may make the catalyst in the combustor inactive. The performance of the catalytic device or its durability has not been evaluated as part of the certification. Metal combustor part number: 20335. Provide adequate outside air for combustion. \*Replace with only ceramic glass, 5 mm. Thickness.

Estimation électrique: (115 VAC, 60 Hz, 0.58 Amps. Risque d'électrocution débrancher le courant avant de réparer l'unité. Ne pas faire courir le fil l'alimentation en avant ou en dessous de l'appareil de chauffage).

AGENCE DE PROTECTION DE L'ENVIRONNEMENT U.S.- STANDARD 2015 - certifié conformément aux normes standard d'émissions de particules 2015 (Méthodes de test 28R et 5G EPA avec un taux d'émission de 0.90 g/hre). Non approuvé pour la vente après le 15 mai 2020. Cet appareil de chauffage au bois nécessite des inspections périodiques et des réparations pour un fonctionnement adéquat. Consulter le manuel du propriétaire pour plus d'informations. Il est contre les règlements fédéraux de faire fonctionner cet appareil de chauffage à l'encontre des instructions d'utilisation fournies dans le manuel du propriétaire, ou si l'élément catalytique a été enlevé ou désactivé. \*UTILISER L'appareil UNIQUEMENT AVEC LES PORTES FERMÉES. Ouvrir la porte SEULEMENT pour alimenter le feu. \*NE PAS OBSTRUER L'ENTRÉE D'AIR DE COMBUSTION. Fournir l'apport d'air extérieur adéquat pour alimenter la combustion. Utiliser uniquement avec des combustibles solides - ne pas brûler aucun autre combustible, ce qui pourrait désactiver le catalyseur de la chambre à combustion. La performance du catalyseur ou sa longévité n'a pas été évaluée dans le cadre de la certification. Numéro du catalyseur: 20335.\* Employer seulement un catalyseur en verre en céramique d'une épaisseur de 5mm si le remplacement de celui-ci est nécessaire.



**CAUTION: HOT WHILE IN OPERATION. DO NOT TOUCH. KEEP CHILDREN, CLOTHING AND FURNITURE AWAY. CONTACT MAY CAUSE SKIN BURNS. READ THIS LABEL AND INSTRUCTION MANUAL BEFORE OPERATING HEATER**  
**ATTENTION: CHAUD LORS DU FONCTIONNEMENT. GARDEZ LES ENFANTS, VÊTEMENTS ET MEUBLES ÉLOIGNÉS. UN CONTACT AVEC LA PEAU PEUT OCCASIONNER DES BRÛLURES. LIRE CETTE ÉTIQUETTE ET LES INSTRUCTIONS D'INSTALLATION AVANT DE FAIRE FONCTIONNER CET APPAREIL.**

**MANUFACTURED IN:**

USA: **Blaze King Industries**  
 146A Street, Walla Walla, WA. 99362  
 CANADA: **Valley Comfort Systems**  
 1290 Commercial Way, Penticton, B.C. V2A 3H5

**MANUFACTURE DATE**

JAN  FEB  MAR  APR  MAY  JUN   
 JUL  AUG  SEP  OCT  NOV  DEC   
 2015  2016  2017  2018  2019  2020

170.0229[0916].jndd

**IF THIS BLAZE KING APPLIANCE IS NOT PROPERLY INSTALLED OR OPERATED, A HOUSE FIRE MAY RESULT. TO REDUCE THE RISK OF FIRE, FOLLOW THE INSTALLATION INSTRUCTIONS. CONTACT LOCAL BUILDING OR FIRE OFFICIALS ABOUT RESTRICTIONS AND INSTALLATION INSPECTION REQUIREMENTS IN YOUR AREA.**

**PLEASE READ THIS ENTIRE MANUAL BEFORE YOU INSTALL AND USE YOUR NEW APPLIANCE. FAILURE TO FOLLOW INSTRUCTIONS MAY RESULT IN PROPERTY DAMAGE, BODILY INJURY, OR EVEN DEATH.**

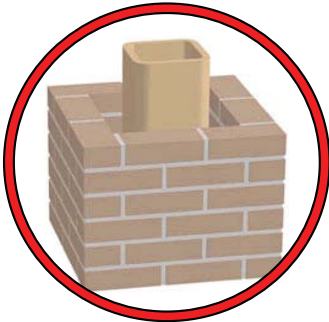

Chimney and chimney connector must be in good condition and kept clean. NEVER vent the stove to other rooms of the building. Must be vented to the outside ONLY. NEVER use a chimney or chimney connector smaller than the stove exhaust, unless approved by your local inspector. NEVER vent the stove into a "Class B" gas vent chimney. DO NOT CONNECT IN CONJUNCTION WITH ANY AIR DISTRIBUTION DUCTWORK UNLESS SPECIFICALLY APPROVED FOR SUCH INSTALLATIONS.

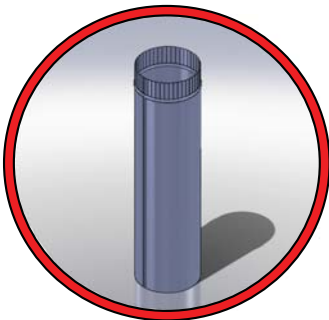

Inspect the chimney connector and chimney regularly during each burning season and clean when necessary. DO NOT CONNECT THIS UNIT TO A CHIMNEY FLUE SERVING ANOTHER APPLIANCE. NEVER intentionally start a chimney fire to clean the flue.



**WARNING: NOT APPROVED FOR INSTALL IN A MOBILE HOME**



If the Optional Fan Kit is installed, connect this unit to a properly grounded, 110-volt electrical outlet. Do not route the power cord in front of or under the appliance.



Do not make any changes or modifications to an existing masonry fireplace or chimney to install this appliance. Do not make any changes to the appliance to increase combustion air.



Never try to repair or replace any part of this appliance unless instructions are given in this manual. All other work must be done by a trained technician.



Do not place clothing or other flammable items on or near this appliance.



Allow the appliance to cool down before carrying out any maintenance or cleaning.



**DO NOT OVER FIRE THIS HEATER.** Attempts to achieve heat output rates that exceed heater design specifications can result in permanent damage to the heater and to the catalytic combustor. Over firing the appliance may cause a house fire. Never burn the appliance so hot that the appliance or chimney connector begins to glow.



Maintain the door and glass seal and keep them in good condition. A leaking door seal will shorten burn times and may harm the combustor.



Do not use a grate or other device to elevate the fire off of the firebox floor. Burn the fire directly on the bricks.



Avoid placing wood against the glass when loading. Do not slam the door or strike the glass.

Do not throw this manual away. This manual has important operating and maintenance instructions that you will need at a later time. Always follow the instructions in this manual.



Ashes should be placed in a steel container with a tightly fitting lid and moved outdoors immediately. If the ashes are disposed of by burial in soil or otherwise locally dispersed, they should be retained in the closed container until all cinders have thoroughly cooled. Other waste shall not be placed in this container.



It is required in some jurisdictions to install smoke and carbon monoxide detectors where heaters are installed. Install at least one smoke detector on each floor of your home to ensure your safety. It should be located away from the wood appliance and close to the sleeping areas. Locating a smoke detector too close to a wood appliance can cause the smoke detector alarm to sound if a puff of smoke is emitted while the wood appliance door is open during reloading. Follow the smoke detector manufacturers placement, installation, and maintenance instructions.



This appliance is designed and approved for burning cord wood only. DO NOT burn trash, garbage; artificial or paper logs; gift wrappings; coal; lighter fluids; chemical cleaners; chemical starters; treated or painted wood; salt water driftwood or foil-backed paper such as gum wrappers or cigarette packages; lawn clippings or yard waste; materials containing rubber (including tires), plastic, asbestos; waste petroleum products, paints or paint thinners, or asphalt products; construction or demolition debris; railroad ties or pressure-treated wood; manure or animal remains; unseasoned wood or paper products, cardboard, plywood, or particleboard. The prohibition against burning these materials does not prohibit the use of fire starters made from paper, cardboard, saw dust, wax and similar substances for the purpose of starting a fire in an affected wood heater. Burning these materials may result in the release of toxic fumes or render the heater ineffective and cause smoke. Burn natural wood only. It will void all warranties and safety listings and may damage the combustor.



Never burn the appliance with the loading door open. Leaving the door cracked open may damage the combustor.

Never block free airflow through vents on this appliance.



Never use gasoline, gasoline-type lantern fuel, kerosene, charcoal lighter fluid, or similar liquids to start or 'freshen up' a fire in this heater.

Keep all such liquids well away from the heater while it is in use. Some fuels could generate carbon monoxide and are very dangerous.



**HOT WHILE IN OPERATION.  
KEEP CHILDREN,  
CLOTHING AND FURNITURE  
AWAY.  
CONTACT MAY CAUSE SKIN  
BURNS.**

Do not touch the appliance when it is hot and educate all children of the danger of a high temperature appliance. Young children should be supervised when they are in the same room as the appliance.



Keep furniture, curtains, wood, paper and other combustibles a minimum of 48in (1219mm) away from the front of the appliance. **ALSO, DO NOT STORE COMBUSTIBLES UNDER THE APPLIANCE (WOOD, PAPER etc.).**

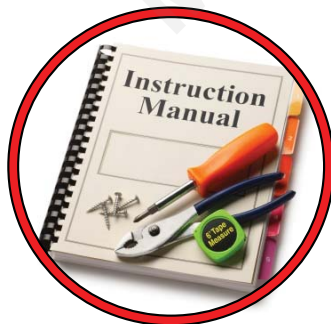

This appliance must be properly installed to prevent the possibility of a house fire. The instructions must be strictly adhered to. Do not use makeshift methods or compromise in the installation.



Contact local building officials to obtain a permit and information on any installation restriction or inspection requirements in your area. Notify your insurance company as well.

**⚠ WARNING**

- BEFORE INSTALLING THIS APPLIANCE, CONTACT THE LOCAL BUILDING OR FIRE OR OTHER AUTHORITY HAVING JURISDICTION AND FOLLOW THEIR GUIDELINES.
- THIS APPLIANCE MUST BE INSTALLED BY A QUALIFIED INSTALLER. FOLLOW THE INSTALLATION DIRECTIONS. DO NOT OPERATE WITHOUT FULLY ASSEMBLING ALL COMPONENTS.
- IF THIS APPLIANCE IS NOT PROPERLY INSTALLED, A HOUSE FIRE MAY RESULT.
- THIS APPLIANCE IS HOT WHEN OPERATED AND CAN CAUSE SEVERE BURNS IF CONTACTED. CHILDREN AND PETS MUST BE KEPT FROM TOUCHING THE APPLIANCE WHEN IT IS HOT.
- COMBUSTIBLE MATERIAL SUCH AS FIRE WOOD, WET CLOTHING, ETC. PLACED TOO CLOSE CAN CATCH FIRE. OBJECTS PLACED IN FRONT OF THE APPLIANCE MUST BE KEPT A MINIMUM OF 48”(1219 MM) FROM THE FRONT OF THE APPLIANCE.

Blaze King grants no warranty, implied or stated, for the installation or maintenance of the appliance and assumes no responsibility of any consequential damage(s).

**PARTS INCLUDED WITH THE ASFORD INSERT**

1. Poker
2. Manual Kit (w/ warranty cards, fire starter, labels)
3. Bypass Handle (Z2052)
4. Part #225.2054 Flue Extension

**REQUIRED SHROUD OPTIONS**

Z2091 Regular Cast Shroud	Z2093 Large Cast Shroud
---------------------------	-------------------------

**FLOOR PROTECTION**

If the bottom of the appliance is 5” (125 mm) or more above the floor level (combustable material) only ember protection is required (UL 1618 type 1) extending 16” (407 mm) in USA or 18” (458 mm) in Canada in front of the door and extending 8” to either side of the door opening.

If the bottom of the appliance is at floor level (combustable material) or less than 5” (125 mm) above floor level, a layer of non-combustible thermal protection (UL 1618 type 2, where R=1.06 minimum) is required under the appliance extending 16” (407 mm) in the USA and 18” (458 mm) in Canada.

**COMPONENTS REQUIRED**

6” stainless steel liner - listed to: UL 1777, ULCS35 OR ULCS640, and part #225.2054 flue extension.

**⚠ WARNING**

**225.2054 FLUE EXTENSION MUST BE INSTALLED IN ALL INSTALLATIONS.**

**MINIMUM CLEARANCES for AF25**

Minimum clearances to combustibles Measured from firebox door flange		
<b>A</b>	Side of door flange to combustible wall.	13.5" / 343 mm
<b>B</b>	Top of door flange to bottom of mantel and combustible facing. (with mantle shield.)	38" / 966 mm (24" / 610 mm)
<b>C</b>	Side of door flange to side of combustible facing.	10" / 254 mm
<b>D</b>	Mantle width maximum. (with mantle shield part #2098)	12" / 305 mm (8" / 204 mm)
<b>E</b>	Minimum hearth side extension *	8"*
<b>F</b>	Mimumum hearth front extension	16" USA / 18" CANADA

\* Measured from each side of the fuel loading and ash removal openings / mesuré de chaque coté de l'ouverture de la porte de chargement et du tiroir de cendre

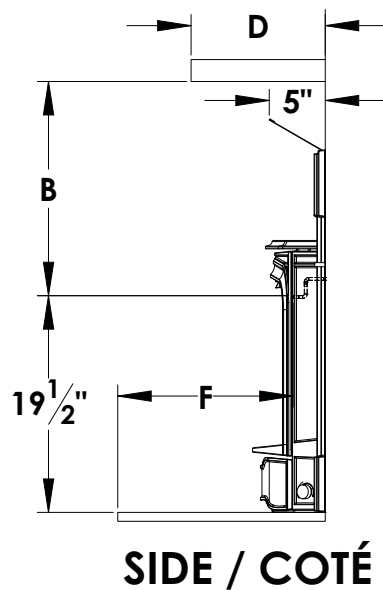
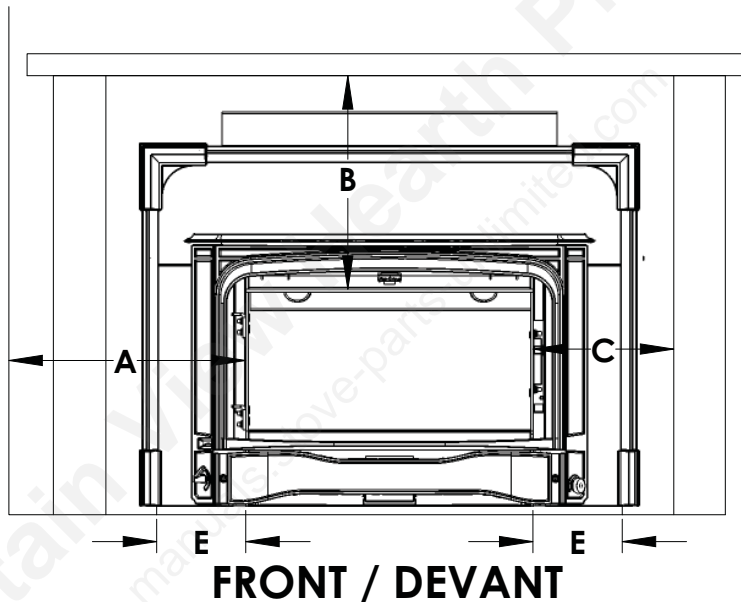

**COMBUSTION AIR**

Ensure adequate combustion air allowing for all other exhausting type appliances in the dwelling (range hoods, dryers, etc.). In air tight homes and modern constructions, careful considerations must be taken into account when using a wood burning appliance. Heat recovery ventilators (HRV) systems along with constant running pan motors in air handlers must be taken into account when balancing the system. Failure to do so may result in air starvation, smoke spillage and carbon monoxide threats. Consult a HVAC specialist for proper installation. Ensure adequate combustion air allowing for all other exhausting type appliances in the dwelling (range hoods, dryers, etc.). In airtight houses it is recommended to install a fresh air inlet into the room where the appliance is located, to prevent air starvation.

**DRAFTING PERFORMANCE**

Draft is the force which moves air into the appliance up through the chimney. The amount of draft created by your chimney depends upon length, offsets, insulating properties, obstructions (such as architectural design, trees), local geography and other factors.

External forces, such as outdoor temperature, wind, barometric pressure, topography, or factors inside the home (negative pressure from exhaust fans, chimneys, air infiltration, etc) may adversely affect draft.

Too much draft may cause excessive temperatures in the appliance and may damage the heater. An uncontrollable burn or excessive temperature indicates excessive draft.

Inadequate draft may cause back puffing (spillage) into the room and plugging of the chimney, chimney cap or spark arrestor screen. Inadequate draft may cause smoke to leak into the room through appliance or chimney connector joints. Poor draft can also lead to poor heat production and the inability for the combustor to remain active in lower burn rate settings.

High efficiency appliances, such as your Blaze King stove, may require some fine tuning of your chimney system in order to maximize performance.

Blaze King cannot be responsible for external forces leading to less than optimal performance.

**ROLE OF THE CHIMNEY**

Without a proper installed chimney, this appliance will not burn correctly.

The role of the chimney is to pull the proper amount of air into the firebox for the purpose of complete combustion. Incomplete combustion will lead to more smoke and pollution of the outside air. A proper operating chimney will allow the user to enjoy peak performance at all burn operating levels from low to high. Blaze King therefore recommends vertical installations with a minimum length of 15' from appliance top to chimney cap. In insert applications Blaze King recommends insulated liners into all existing chimneys.

### INSPECT CHIMNEY

Before connecting any wood-burning unit to an existing chimney, inspect the chimney to be sure that it is in good condition. There must be no cracks or holes. The cross-sectional area can differ from the flue collar as long as sufficient draw is maintained and local codes and jurisdiction are observed.. A proper chimney is crucial for safe, satisfactory operation of any wood heating system. Relining or rebuilding may be necessary to make the chimney safe, efficient, and in conformity with local codes.

Masonry Chimneys that have a very large cross-section , particularly exterior chimneys, may experience poor draft and may require relining to reduce the cross-section-and provide a proper draft. This is also an ideal time to clean the existing chimney. For peak efficiency, a clean chimney flue is essential. A qualified professional chimney sweep can perform both inspection and cleaning. If you choose to clean your own chimney use the proper tools. Homemade cleaners may damage your chimney.

### PLANNING STOVE PLACEMENT

**NOTE: THIS INSERT IS SUITABLE FOR INSTALLATION IN EITHER:**

- **A FACTORY BUILT FIREPLACE LISTED TO UL 127 OR ULC S20**
- **A CODE-APPROVED MASONRY CHIMNEY WITH A FLUE LINER. MANDATORY in CANADA, recommended in USA.**

Check the fireplace and insert dimensions to ensure the insert will fit properly. While planning your installation keep in mind the required clearances as shown on the stove label.

Plan ahead to be certain that furniture will have ample clearance, and that drapes and curtains cannot come in contact with the room heater. Refer to the approval label on the stove for correct clearances to combustibles.

This stove must be connected to a chimney. It must be vented to the outside.

## **WARNING**

**NEVER PERMIT YOUR STOVE TO VENTILATE INTO ANY ROOM IN THE BUILDING**

Consult the stove label to ensure that you install your stove the proper minimum distances from combustible materials.

Minimum fireplace opening size is 29" x 22" x 19" (W x H x D)

Electrical Power - The stove is equipped with a fan assembly with a 10-foot electrical cord. Do not route the cord in front of the stove.

## **WARNING**

**THE FIREPLACE IS SHIPPED WITH THE FRONT CAST ASSEMBLY ATTACHED, THIS ADDS CONSIDERABLE WEIGHT TO THE STOVE, IT ALSO MAKES THE FIREPLACE WIDER. SHOULD THE FIREPLACE BE TOO HEAVY OR TOO WIDE TO POSITION, IT IS POSSIBLE TO REMOVE THE FRONT CAST ASSEMBLY TEMPORARILY, THEN REATTACH WHEN THE FIREBOX IS ALMOST IN POSITION (SEE "FRONT CAST REMOVAL" ON THE NEXT PAGE). IF NOT REMOVING THE FRONT CAST ASSEMBLY GO TO STEP 1 OF "STOVE ASSEMBLY".**

## FRONT CAST REMOVAL

1. Disconnect the two rheostat wires from the front cast assembly. Open the loading door. Remove eight 1/4-20 nuts from top brackets and side posts with a 7/16" wrench. Remove two 10-24 nuts from analog cat therm using a 3/8" wrench. Slide the cast assembly away from firebox and set aside. Position firebox in front of fireplace opening (**Fig. 1**). To re-attach the front cast assembly simply reverse these steps.

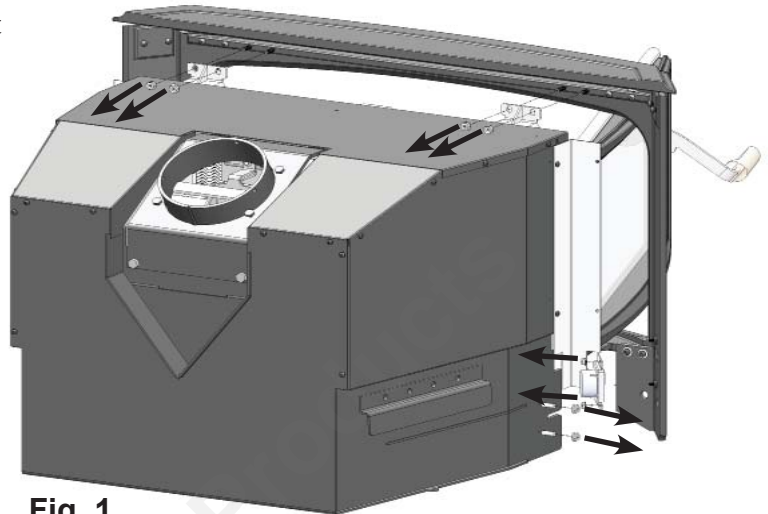

Fig. 1

## STOVE ASSEMBLY

### Bypass door wedge removal

1. Position stove in front of fireplace opening, and open loading door.
2. Remove the two nuts from inside the firebox that hold flue collar assembly in place, use a 9/16" wrench (**Fig. 2**). Ensure gasket is still fully intact and adhered to flue collar base. Set flue collar assembly aside until "**flue collar preparation**" later in installation.

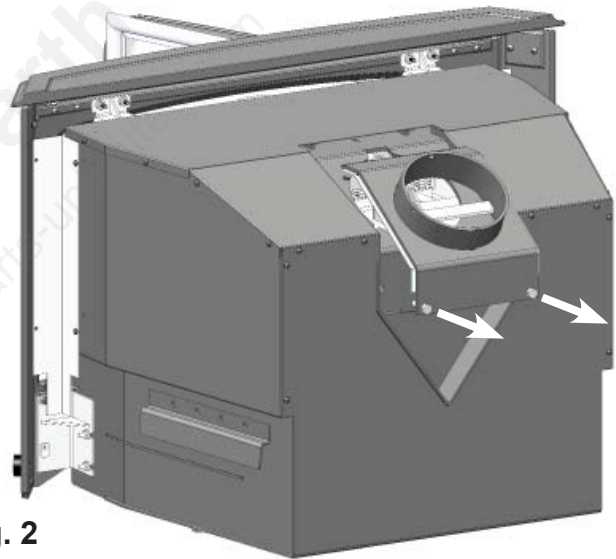

Fig. 2

### Thermostat rod installation

3. Ensure fans have not shifted during transport and are in correct position.
4. Slide thermostat rod in from side of cast, then align machined faces of rods and secure with the set collar. (**Fig. 3**)

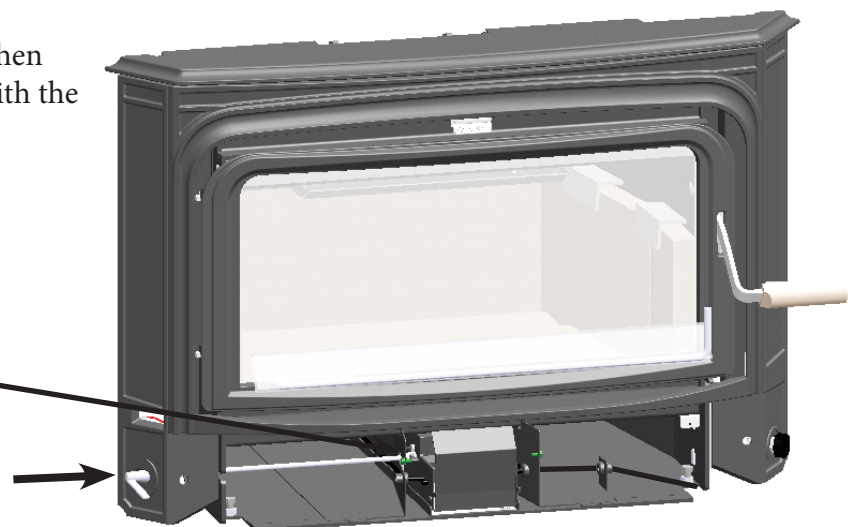
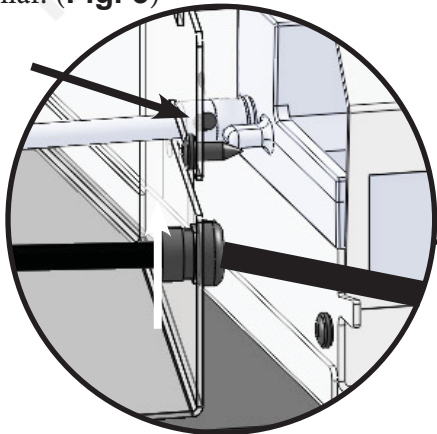

Fig. 3

5. Determine which side the nearest electrical outlet is then feed electrical cable through lower back corner of the cast facing on that side. Ensure wiring is tucked above the protruding flanges of the front cover. (Fig. 4)

**NOTE: IF POWER CORD IS RUN THROUGH THE RIGHT SIDE OPENING THEN ENSURE THAT THE EXCESS WIRE IS SECURED WITH A ZIP TIE TO AVOID POTENTIAL INTERFERENCE WITH FAN.**



Fig. 4

6. Slide shroud down behind front cast and fasten to firebox with seven #8 x 1/2 screws. The bypass door handle bracket can be screwed to either side of the shroud. If the mantle shield is being used it should be installed at this time using the top two screws of the shroud. (Fig. 5)

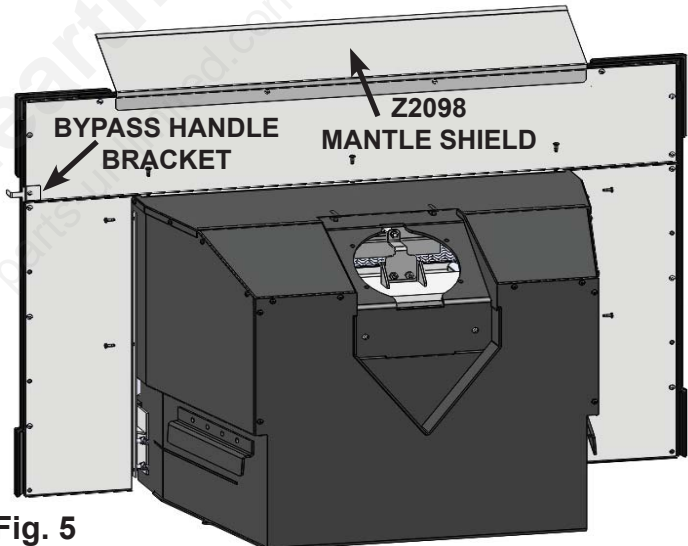

Fig. 5

7. Position stove in fireplace opening. If required, use the four leg leveler bolts to level the firebox. (Fig. 6)



Fig. 6

8. Fasten lower cast cover to cast face using a 5/32" alan key, two screws. (Fig. 7)

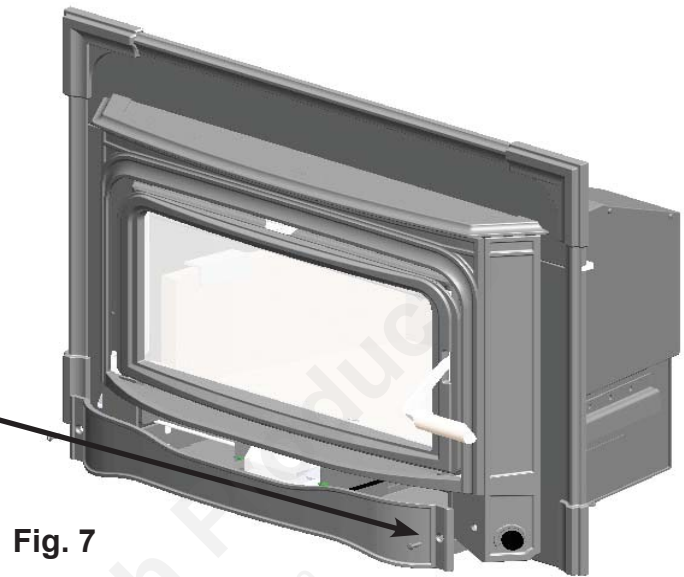
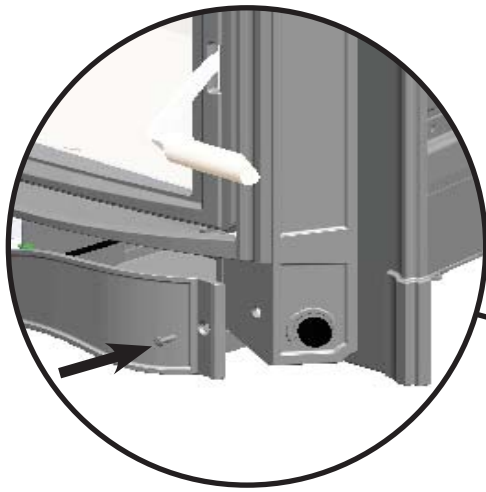

Fig. 7

### Flue Collar Preparation

1. For ease of install; once chimney piping is completely installed and attached to the provided flue collar / flue extension, leave flue collar hanging roughly 2 feet above the floor of the fireplace. This will enable unit to be pushed back into the fireplace opening without interference and allow for an easy grab through the bypass door opening to install. Ensure 1/4" gasket is intact on the bottom of the flue collar assembly before installation. (Fig. 8)

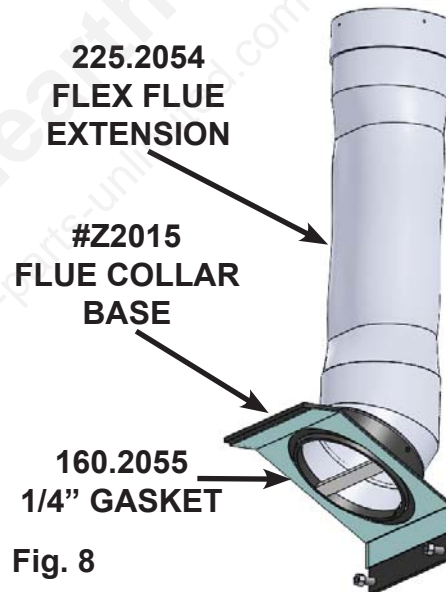
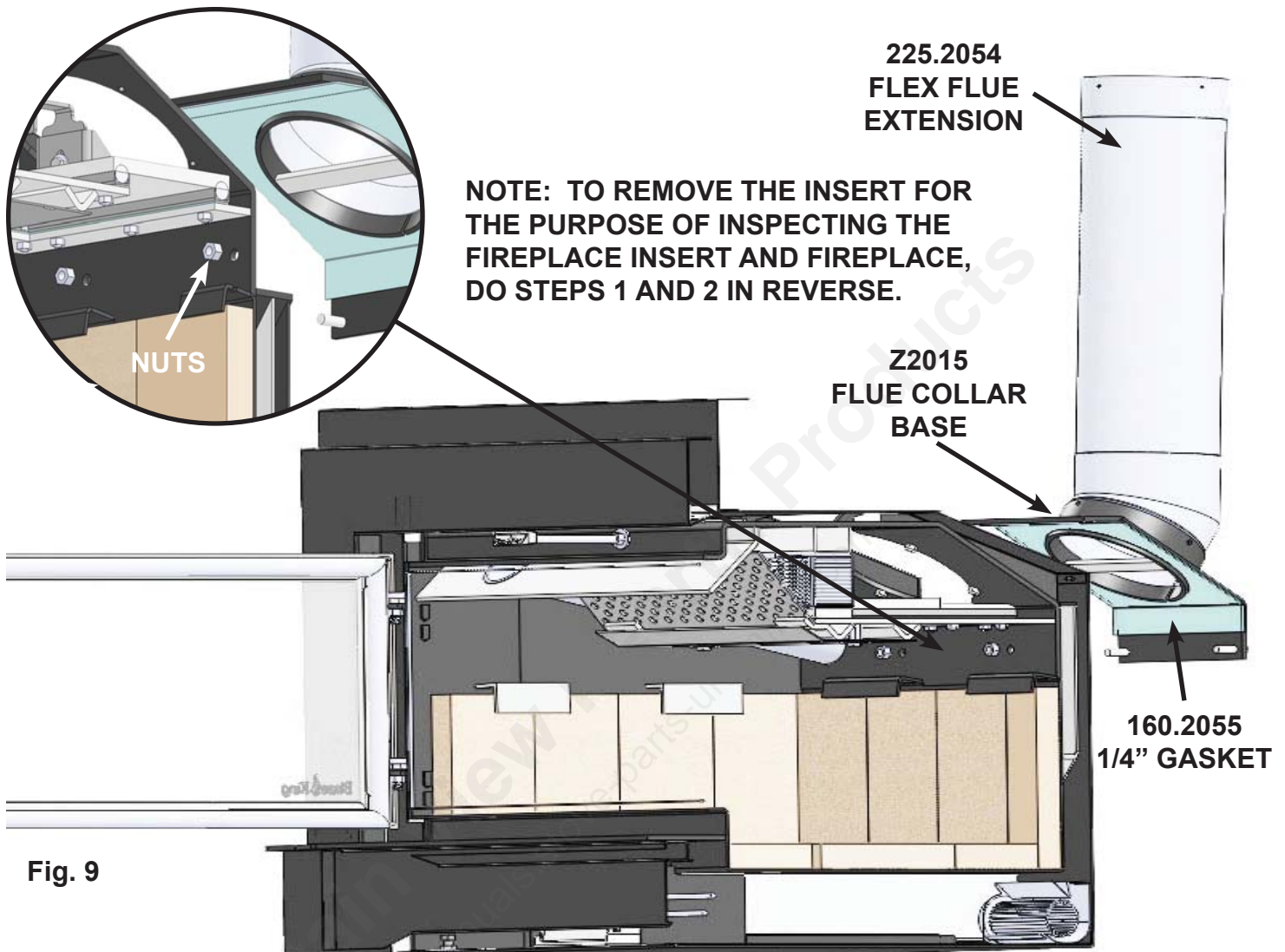

Fig. 8



### Flue Collar Installation

1. Open loading door and bypass door then reach up through bypass opening to grab flue collar assembly. Pull down to align bolts with through holes in firebox rear then pull forward.

**NOTE: ENSURE TOP SURFACE IS MATING WITH FIREBOX TOP. THE GASKET OF THE FLUE COLLAR NEEDS TO BE IN CONTACT WITH THE FIREBOX ON ALL SIDES. FEEL THE AREA WHERE THE FLUE COLLAR MAKES CONTACT WITH THE FIREBOX, IF THERE IS A GAP, THE FLUE COLLAR IS NOT SEATED PROPERLY AND NEEDS TO BE REALIGNED.**

2. Once sealed, fasten flue collar assembly to firebox using a 9/16" wrench, and the supplied stainless steel nuts (**Fig. 9**). Tighten flue adapter bolts evenly so a tight seal is maintained.

## **⚠ WARNING**

**225.2054 FLUE EXTENSION MUST BE INSTALLED IN ALL INSTALLATIONS.**

## CHIMNEY

## FACTORY-BUILT FIREPLACE

In Canada and in the USA: This insert may be installed into a compliant factory built fireplace providing the chimney is lined from the outlet of the insert to the top of the chimney using an insulated stainless steel liner which meets UL1777 or ULC S635. The liner must be securely attached to both the insert and the chimney top. In both Canada and the U.S.A. the existing fireplace damper must be secured in the open position. If this is not possible the damper must be removed. Any openings between the masonry of the fireplace and the facing masonry must be sealed.

**⚠ WARNING****THE FIREPLACE CANNOT BE MODIFIED IN ANY WAY TO FIT THE INSERT**

## GENERAL CHIMNEY INSTALLATION

Connect the venting system to the flue collar of the insert using three sheet metal screws. There are three predrilled holes in the flue collar. Place a bead of furnace cement around the flue collar connection to ensure the flue pipe is properly connected, secured and sealed.

If this stove and its chimney components are not properly installed, a house fire may result. For your safety, follow the installation directions. Contact local building or fire officials about restrictions and installation requirements in your area.

We recommend that the inside your chimney be at least the same diameter as the flue of your stove. If you plan to use an existing masonry chimney, be sure it is free of cracks and loose joints. Gases traveling through a chimney can reach extremely high temperatures. Cracks or loose mortar can allow hot gases to reach the wood portion of the structure surrounding the chimney. These toxic gases can also re-enter the house through cracks and small holes in the chimney, or cause back-puffing which will result in excessive smoking. Be on the safe side and have your chimney inspected by a certified chimney sweep. A 6 inch insulated stainless steel chimney liner with a direct connection to the stove is recommended for masonry chimney installations. A chimney must extend at least three feet above the highest point where it passes through the roof and at least two feet higher than any portion of the building within ten feet of the chimney. Smoke travels up the chimney in a circular, spiraling motion. A 6 inch round insulated stainless steel liner allows the smoke to travel with less resistance. A rough masonry chimney without a good smooth liner can result in the rapid build up creosote.

**⚠ WARNING**

- **BEFORE YOU BEGIN CHECK ALL LOCAL CODES AND REGULATIONS REGARDING YOUR INSTALLATION.**
- **DO NOT CONNECT THIS UNIT TO A CHIMNEY FLUE SERVING ANOTHER APPLIANCE**

**YOUR FIRST FIRE!**

The following pages contain information on the major components and operation of your heater. Please take time to read about them as it will give you a better understanding of how your appliance works. This understanding will help you to operate your appliance properly thus will extend the life of your appliance and allow you to get the highest efficiencies from your heater.

**THERMOSTAT**

The thermostat knob is located on the lower left side of the front cast assembly. It controls the burn rate of the stove. Any thermostat position between **LOW**(thin line) and **HIGH**(wide line) will produce the desired clean burning characteristics. However, since each installation is different, you may find it necessary to operate the thermostat to suit your situation. A **HIGH**(wide line) thermostat setting will produce maximum heat which is more than suitable for heating the average size home. All adjustments to the thermostat should be done gradually. When you first light the stove set the thermostat to **HIGH**(wide line) setting for 20-30 minutes, or until the fire is well established. Once the fire is established turn the thermostat to **MED**(middle of line) for 5 minutes and then to a **LOW**(thin line) setting or the desired setting. Too rapid an adjustment may cause the stove to operate improperly. The most common mistake new owners make is continually adjusting the thermostat.

**LOW**(thin line)**MED**(middle of line)**HIGH**(wide line)**BYPASS**

Most catalytic wood burning appliances have a bypass device to allow the smoke from the fire to temporarily bypass, or go around, the catalytic combustor. The bypass door is located inside the firebox at the top of the stove. The bypass is a steel plate door, and is controlled by the bypass rod and latch above the door in the middle of the stove. Use the bypass handle on the side of the latch (**Fig. 10**) to pull the rod out, then the bypass is open, use the bypass handle on the center of the latch to push the rod in, then the bypass is closed (**Fig. 11**). The bypass handle is hung from a bracket on either the left or right side of the shroud.

**NEVER OPEN THE LOADING DOOR WITHOUT OPENING THE BYPASS DOOR**

**⚠ WARNING**

**DO NOT TOUCH THE BYPASS LATCH DIRECTLY, ALWAYS USE THE BYPASS HANDLE. DURING OPERATION THE BYPASS LATCH GETS VERY HOT AND CAN CAUSE SERIOUS BURNS.**

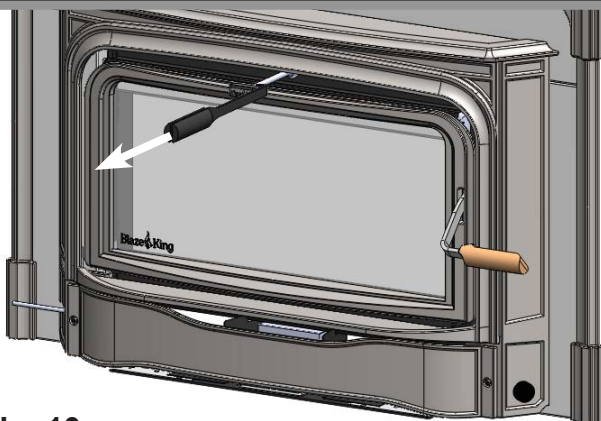
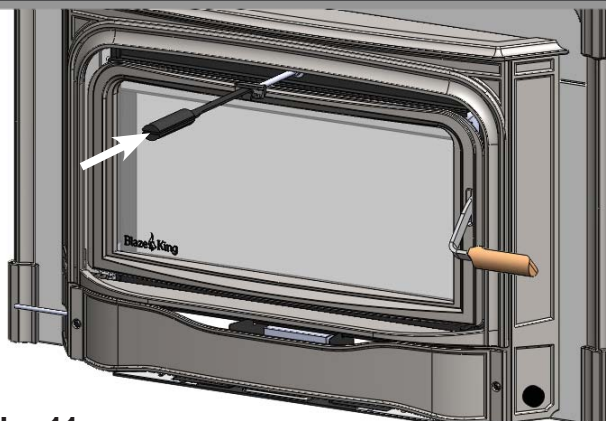
**Fig. 10****Fig. 11**

### CATALYTIC THERMOMETER

The catalytic thermometer is located in the lower left-hand corner of the cast surround. (Fig. 12) Its purpose is to show you if the combustor is active. Always operate the stove when the needle is in the active red zone. When the combustor is not active the stove will emit smoke and will not be efficient. For an accurate reading, turn fans off for approximately 10 minutes and then read the thermometer.

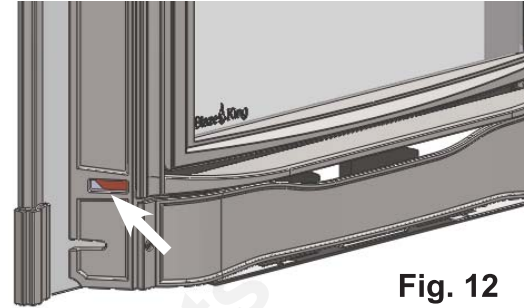

Fig. 12

### SELECTING WOOD

#### **⚠️ WARNING**

- **THIS APPLIANCE IS DESIGNED TO BURN NATURAL WOOD ONLY. DO NOT BURN TREATED WOOD, COAL, CHARCOAL, COLORED PAPER, CARDBOARD, SOLVENTS OR GARBAGE.**
- **HIGHER EFFICIENCIES AND LOWER EMISSIONS WILL GENERALLY RESULT WHEN BURNING AIR DRIED SEASONED WOODS, AS COMPARED TO WET, GREEN OR FRESHLY CUT WOODS.**
- **BURNING WET UNSEASONED WOOD CAN CAUSE EXCESSIVE CREOSOTE ACCUMULATION. WHEN IGNITED IT CAN CAUSE A CHIMNEY FIRE THAT MAY RESULT IN A SERIOUS HOUSE FIRE.**

Use dry seasoned wood, split and stacked and protected from rain for at least 24 months with a moisture content of 20% or lower. It takes a great deal of energy to evaporate the moisture contained in green wood and that energy will not be heating your house. Also, green or wet wood will greatly increase creosote problems. The only accurate method to determine moisture content in wood is to use a moisture meter.

Never burn salt-water driftwood. It is very corrosive and will damage the firebox. Burning salty wood also voids the warranty.

This controlled combustion firebox has been designed for high efficiency and long burn times. The proper time to add more wood is when the last charge has been reduced to a glowing charcoal bed and while the catalytic thermometer is still active range. There will be very little smoke at this stage in the burn cycle.

Both hardwood and softwood burn equally well in this appliance but hardwood, which is more dense, will weigh more per cord and burn a little slower and longer.

Firewood should be split and stacked in a manner that air can get to all parts of it and covered in early spring to be ready for burning that fall.

**The only accurate way to determine wood moisture is to purchase a moisture meter.**

#### **⚠️ WARNING**

- **NEVER START A FIRE UNLESS ALL BRICKS ARE CORRECTLY PLACED INSIDE THE FIREBOX. CHECK THE INSTALLATION INSTRUCTIONS CAREFULLY.**
- **ALWAYS OPEN THE BYPASS DOOR BEFORE OPENING THE LOADING DOOR.**
- **ONCE THE LOADING DOOR IS CLOSED, CLOSE THE BYPASS DOOR DIRECTLY AFTER THE CATALYTIC THERMOSTAT NEEDLE IS IN THE ACTIVE ZONE.**

### HOW TO USE MOISTURE METERS

1. Take a random selection of around 3-4 logs per cubic yard or cubic meter.
2. Split each log down the middle.
3. In the center of log push pins of meter along grain - three measurements are taken on the freshly split surface: 2" or 5 cm in from each end of the log and in the middle of the split surface with sufficient contact (see figure).
4. Do this to all the logs and take an average of the readings (this will be only an approximate indication but a good guide).

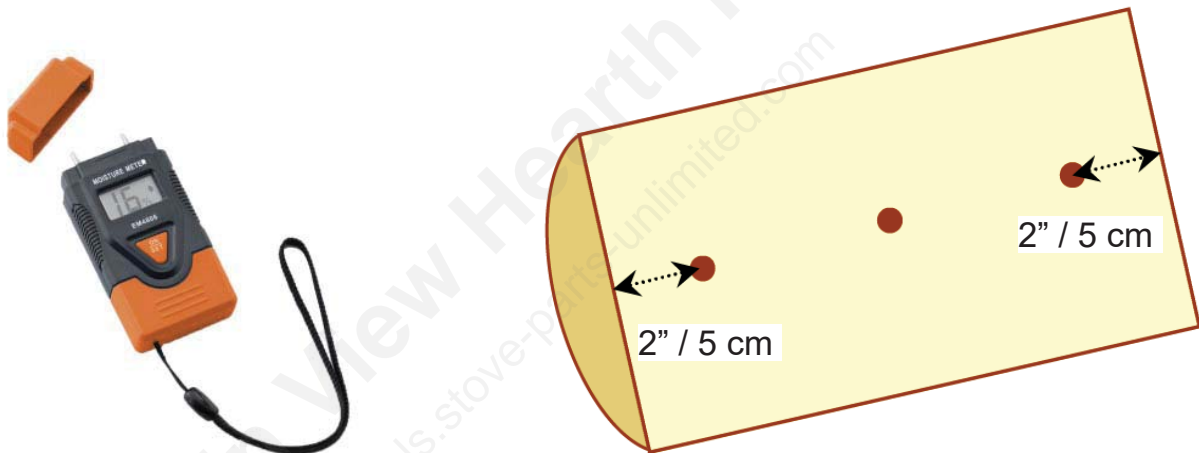

### EFFICIENCY

Efficiency was determined using the method outlined in B415.1-10 test method. It is represented by the Higher Heating Value (HHV) as the fuel used during testing contains between 19% - 25% water moisture included in the total calculated fuel weight. (Other test methods such as LHV or Low Heating Value, do not take the water moisture into account).

Annual Fuel Utilization Efficiency (AFUE) attempts to represent the actual, season long, average efficiency of an appliance. HHV is the actual, calculated average efficiency obtained under test conditions. Using correctly seasoned wood is important when trying to gain efficiency. The more seasoned (dry) the wood, the higher the efficiency (less energy wasted on eliminating moisture during combustion). Operating your Blaze King at lower settings will result in higher efficiencies as the fuel will undergo a more complete combustion.

## LIGHTING THE FIRE

NOTE: As you heat up the stove for the first time, the paint will go through a curing process and will give off an odor. To minimize the inconvenience, burn the stove at a low temperature setting for several hours. It is advisable to open a door or window until the odor dissipates. You may also notice a change in color as the paint cures, this is normal and will appear uniform after subsequent firings.

1. **DO NOT USE A GRATE. BUILD THE FIRE DIRECTLY ON THE BRICK IN THE BOTTOM OF THE APPLIANCE.**
2. Set the thermostat to **HIGH** (maximum) position and turn the fan **OFF**.
3. Open **BOTH** the loading door and the bypass door (bypass latch / rod pulled out using bypass handle).
4. Place 10-20 balls of non-glossy paper on the floor of the firebox, or use a Blaze King fire starter puck, and then stack 8-10 lbs of kindling on top of the paper in a crisscross fashion. Be sure to space out the kindling to allow air to flow throughout the firebox.
5. Light the balls of paper, or starter puck, and leave the loading door cracked at least 2" to allow the kindling to fully ignite. This should take approximately 5 minutes. **DO NOT LEAVE THE APPLIANCE UNATTENDED.**
6. Once the kindling load is fully engulfed, latch the loading door shut **BUT** keep the bypass door open in order to get the catalytic combustor up to operating temperature. This is signified by the needle on the catalytic thermometer moving towards the red "active" zone. This should take no longer than 10 minutes.
7. After 10 minutes and/or once the needle on the catalytic thermometer is in the red "active" zone, close the bypass door (push the bypass latch / rod in using the bypass handle). **LEAVE THE THERMOSTAT ON HIGH.**
8. Let the kindling load burn down to small chunks of wood in order to build a 2-3" thick coal bed. This should take 15-25 minutes of continuous burning on **HIGH**.
9. While waiting for the kindling load to burn down, **PREP YOUR MAIN FIREWOOD LOAD.** The ideal wood load for this unit consists of: 3-4 pieces cut to 16" for the bottom row (to be placed into the unit in a front to back orientation) and 1-2 pieces cut to 18-20" for the top row (to be placed into the unit in a side to side orientation). The main load should weigh 20lb – 40lb (will vary based on wood species used).
10. Once satisfied that a suitable coal bed can be achieved, **OPEN THE BYPASS DOOR AND THEN THE LOADING DOOR** and stir up the kindling to form the coal bed. Ensure it is evenly distributed over the entire firebox floor.
11. With both the loading door and bypass door still open, insert your main firewood load (see step 9 for ideal orientation). Once loaded, **CLOSE YOUR LOADING DOOR AND THEN YOUR BYPASS DOOR IMMEDIATELY.**
12. Let the appliance burn with the thermostat set to **HIGH** for 10 – 20 minutes or until the fire is well established. Turning the thermostat down too soon could cause the fire to go out.
13. Once satisfied that the fire is fully established, the thermostat can be adjusted down to the desired heat output setting.
14. The fan can be turned on once the appliance is hot or 20-30 minutes after the initial loading period.

It is good burning practice to burn the stove on **HIGH** for 20 to 30 minutes after every refuelling, this will help to condition the wood load for optimum combustion. The temperature in the stove and the gases entering the combustor must be raised to at least 500° (indicated by the thermometer needle in the active red zone) for catalytic activity to be initiated. During the start-up of a cold stove, a high fire must be maintained for at least 20-30 minutes. This ensures that the stove, catalyst, and fuel are all stabilized at proper operating temperatures. Even though it is possible for flue gas temperatures to reach 600° within 5 minutes of a fire being started. If the fire is allowed to die down immediately (thermostat set to a **LOW** setting too soon), it may go out or the combustor may stop working, indicated by the thermometer needle being in the inactive zone. Once the combustor starts working, heat generated in it, by burning the exhaust smoke, will keep it working.

Probably the least understood requirement in maintaining a good fire is that of establishing a good base of coals or embers. A good bed of hot coals or embers will maintain a more even temperature as well as getting the new load of wood started easily. Put as much fuel into the stove as it will hold. Don't be afraid to fill it completely. With the Blaze King automatic thermostat, the wood will only burn at the rate set on the thermostat. Once the full load is established, the stove should be left to complete the full burn cycle. This is evident by either a coal bed (ember bed) remaining or the catalyst's thermometer hovers just inside the active zone. This procedure will maximize the efficiency of the combustor as well as limit chimney emissions and smoke spillage.

**⚠ WARNING****DO NOT USE THE APPLIANCE WITHOUT A COMBUSTOR****RELOADING PROCEDURE (with the catalyst temperature in the active red zone)**

1. Have your next load of wood ready before beginning. Turn the thermostat to **HIGH** and turn the fan off. Wait 2 minutes for the air flow to stabilize.
2. Open the bypass door (bypass latch / rod pulled out using bypass handle) and again wait 2 minutes for the air flow to stabilize.
3. Unlatch the loading door and open just a crack to allow the ambient room air to be introduced to the firebox, this may take a few seconds to stabilize.
4. Slowly open the loading door and proceed to reload the firebox. If you experience excessive smoke spillage, slightly close the loading door to re-establish a draft through the chimney.
5. Once loaded, latch the loading door shut and close the bypass door (push the bypass latch / rod in using the bypass handle). Let the fire burn on the **HIGH** thermostat setting for 20 to 30 minutes **OR** until the fire is very well established. At that point, turn the thermostat down to the desired setting. Keep in mind you may not see a large amount of flame activity in the lower thermostat setting. The thermometer needle will remain in the active zone indicating that the burn cycle is continuing.
6. Should you burn the stove on a very low setting for extended periods of time, you will begin to see creosote deposits forming on the glass door. To remove these deposits, simply run the stove on **HIGH** for approximately 30 minutes. The **HIGH** setting will burn off most of the deposits.

As every pile of wood is different you will learn, over time, which settings are necessary to achieve the optimal fire. This will be based on the type of wood, installation, weather conditions and the desired room temperature.

**RELOADING PROCEDURE (with the catalyst temperature still in the inactive zone)**

Follow the procedure for "LIGHTING THE FIRE" on the previous page.

### OPTIMAL THERMOSTAT SETTING

Any thermostat position between **LOW** and **HIGH** will produce the desired clean burning characteristics. However, since each application can vary, you may find it necessary to operate the thermostat to suit your application. A thermostat setting on **HIGH** will produce a maximum heat which is more than suitable for heating the average size home and offer the cleanest door glass.

1. Starting the fire. Each stove, home, installation, chimney installation, and homeowner combination works a little differently. The first several times you fuel the stove, it may not react as you expect. A little experimentation may be needed to find the right combination of fuel and thermostat setting to achieve the maximum efficiency. This is one of the joys of burning wood. You, the wood burner, make it work. And you can see what happens as it is working. Be patient, the air / fuel mixture and temperature must be stabilized before maximum combustion efficiency can be achieved.
2. As the combustor temperature (as indicated by the thermometer) passes into the active red zone, further adjustment to achieve the desired room temperature should be made in small increments for the most effective cleaner burning operation. Changes should be made as few times each day as possible. When the thermostat knob is moved from high to low, more gases are produced, so the combustor has more fuel; consequently the combustor thermometer may register a higher heat for several hours after the thermostat is turned down.
3. Keep hot coals active so when you reload the stove you will reduce the time necessary to maintain an active combustor.
4. The thermostat is set at the factory. **DO NOT TAMPER WITH THE THERMOSTAT**, this will result in a malfunctioning thermostat.

### FAN OPERATION

The fans are located beneath the firebox of the stove, it recirculates room air up the back and across the top. This design allows the air to travel the farthest distance across the hot surfaces resulting in super heated air, most of which can be felt exiting the top of the stove. The fan should be off until the stove reaches normal operating temperatures. After approximately 30 minutes, the fan speed adjustment should match the thermostat control setting, i.e. if your stove is set at medium then your fan should also be set at medium, low—low, high—high etc. The fan control is on the right-hand side of the lower shroud / ash shelf.

### ICE - FORMATION AND PREVENTION

Most of what you see coming from the chimney of a properly operating catalytic appliance is water vapor. In extremely cold weather - and with some exterior chimneys - this vapor may freeze in the chimney, to the point of actually blocking the chimney and extinguishing the fire. In such weather, occasionally burn the appliance for 4 or 5 minutes with the thermostat setting on **HIGH** to melt any possible ice buildup.

**WOOD BURNING IN THE SHOULDER SEASON**

There are things to consider if you decide to light a fire in the spring and fall or when the outside temperature is milder, perhaps 55°F to 70°F (13°C to 21°C).

As you light the fire, with the loading door open, you may notice spillage, this is when a small amount of smoke comes back into the living space. When your fire begins to warm the chimney and the draft improves, spillage is greatly reduced. After a short period of time you can adjust the thermostat to a **LOW** setting and maintain a comfortable temperature in your home.

In reducing the thermostat setting you have also reduced the flue temperatures and your chimney begins to cool down. At this time the amount of draft is also decreasing and spillage may occur. The differences between the flue temperature and the outdoor air temperatures causes your chimney to draw and vent the flue gasses to the outside. This air movement, sometimes referred to as Stack Effect, is also influenced by air density and moisture differences. Small temperature differences produce less draw in your chimney system than large temperature differences.

General Rules for burning in the shoulder season:

- Run your appliance on high for 30 minutes after start up and reloading.
- Slowly turn the thermostat down to the desired heat setting.
- The heat setting needs to be high enough to keep the thermometer in the active zone.
- If the thermometer does not stay in the active zone turn the thermostat to a higher setting. Wait 15 minutes then confirm that the thermometer remains in the active zone. Repeat as needed.
- If your appliance is producing too much heat, build smaller hotter fires.

It is important to periodically monitor the operation of the catalytic combustor to ensure that it is functioning properly. A non-functioning combustor will result in a loss of heating efficiency, and an increase in creosote and emissions. Following is a list of items that should be checked on a periodic basis:

- Combustors should be visually inspected at least three times during the heating season to determine if physical degradation has occurred. Actual removal of the combustor is not recommended unless more detailed inspection is warranted because of decreased performance. Refer to “CATALYTIC COMBUSTOR TROUBLESHOOTING” on next page.
- This catalytic heater is equipped with a temperature probe to monitor catalyst operation. Properly functioning combustors typically maintain temperatures in excess of 500°F (indicated by the thermometer needle in the active zone), and often reach temperatures in excess of 1000°F. If catalyst temperatures fall below 500°F (indicated by the thermometer needle in the inactive zone), refer to next step and to “CATALYTIC COMBUSTOR, TESTING” below.
- You can get an indication of whether the catalyst is working by comparing the amount of smoke leaving the chimney when the smoke is going through the combustor and catalyst light-off has been achieved, to the amount of smoke leaving the chimney when smoke is not routed through the combustor (bypass mode):
  - Light the appliance as per the lighting instructions “LIGHTING THE FIRE”. With smoke routed through the catalyst, go outside and observe the emissions leaving the chimney.
  - Open the bypass mechanism, wait approximately 15 minutes, and again observe the emissions leaving the chimney. Significantly more smoke will be seen when the exhaust is not routed through the combustor (bypass mode). Some smoke may be visible shortly after you start the fire and shortly after reloading the fire. Allow 20 to 30 minutes for the fire to stabilize before making observations.

### CATALYTIC COMBUSTOR, TESTING

Light the fire as per the lighting instructions (see LIGHTING THE FIRE). Then set the thermostat knob on a **MED** setting. When the fire is well established (within one to three hours) turn the thermostat knob between **LOW** and **MED**. A properly operating combustor will remain active, and the combustor thermometer will remain in the “active” zone until the wood load is mostly consumed. A “tired” or “dead” combustor will, with the thermostat on **MED** or lower, go out completely, and the thermometer needle will fall into the “inactive” zone. Repeat this procedure several times over several days (Remember that the combustor thermometer has a built-in lag of 4-8 minutes.) If, after several test burns, the thermometer will not indicate an “active” combustor, it may require cleaning or replacement. It is also possible that the thermometer, itself, may not be reading accurately. Before condemning the combustor, read “THERMOMETER”. If, after cleaning has been performed, your combustor is still not working you can Contact Blaze King for a replacement combustor. Please read “REPLACEMENT PARTS” section in this owners’ manual.

### CATALYTIC COMBUSTOR, CLEANING

Under certain conditions, ash particles may become attached to the face of the combustor. These may be seen while the combustor is in the glowing stage, or when the fire is out. Any deposit on the visible face of the combustor should be removed. Wait until the fire is out and the appliance is cold before performing any cleaning. Brushing the combustor with a soft bristle paint brush will remove some deposits. Passing a vacuum cleaner wand or brush near the face of the combustor will remove most deposits. (Hot ash in a vacuum cleaner bag will burn, may melt the vacuum or cause a house fire. Exercise caution and never clean the appliance when the appliance or ashes are hot.) Never scrape the combustor with any hard tool or brush. Never run pipe cleaner through the individual cells of the combustor. This is not needed, and may do more harm than good. Limit cleaning to the face of the combustor. **NOTE: Never remove a combustor without approved combustor gasket in hand as original gasket will fall apart when removed from appliance.** Remember to re-install the Flame Shield (the perforated plate) in same position it was found.

TIP: A hot fire will usually prove to be the best method of cleaning the combustor of deposits.

## CATALYTIC COMBUSTOR, TROUBLESHOOTING

**PROBLEM - CREOSOTE PLUGGING**

**Possible Cause:** Burning materials that produce a lot of char and fly-ash.

**Solution:** Do not burn materials such as garbage, gift wrap, or cardboard.

**Possible Cause:** Burning wet, pitchy woods or burning large loads of small diameter wood with the combustor in the operating position without the thermostat needle in the active zone.

**Solution:** Burn dry, seasoned wood, don't engage the bypass until the temperatures are high enough to initiate light-off (indicated by the thermostat needle in the active zone).

**Possible Cause:** Combustor not functioning. If proper burning procedures have been followed to no avail, the combustor is not functioning.

**Solution:** Replace the combustor with a genuine Blaze King combustor (failure to do so will void your warranty).

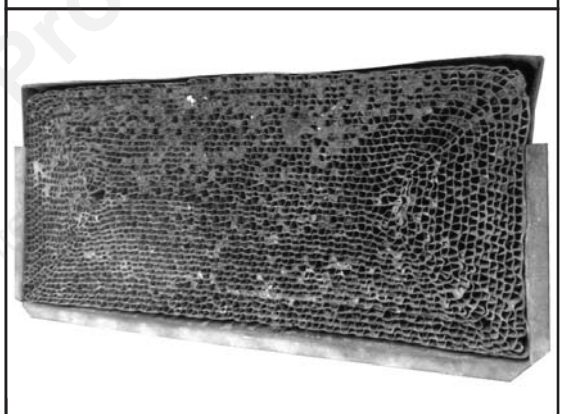
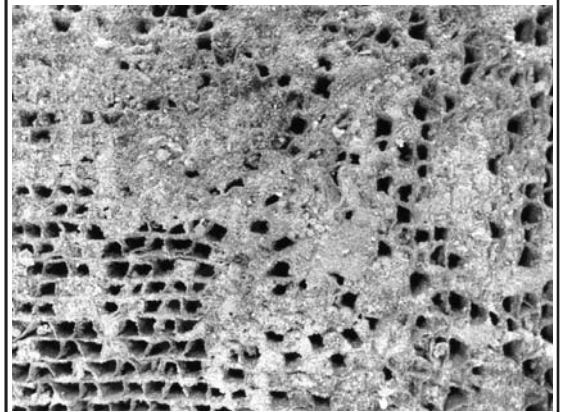
**PROBLEM - CATALYST PEELING**

**Possible Cause:** Extreme temperatures (above 1800°F, or 1000°C.) at combustor surface can cause the catalysts to peel. Over firing and flame impingement on the combustor are primary causes. Minor peeling photo shows minor peeling that is normal and does not affect function. Severe peeling photo shows that are closed or plugged.

**Solution:** Avoid extreme temperatures and flame impingement. If peeling is severe, remove and replace combustor.

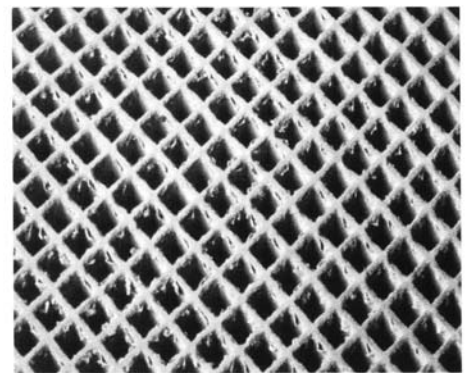

Minor Peeling

**PROBLEM - CATALYST DEACTIVATION**

**Possible Cause:** Burning large quantities of trash, pressure-treated lumber, or painted woods.

**Solution:** Burn quality woods available in your area. If you decide the catalyst has been deactivated, replace combustor with a genuine Blaze King combustor (failure to do so will void your warranty).

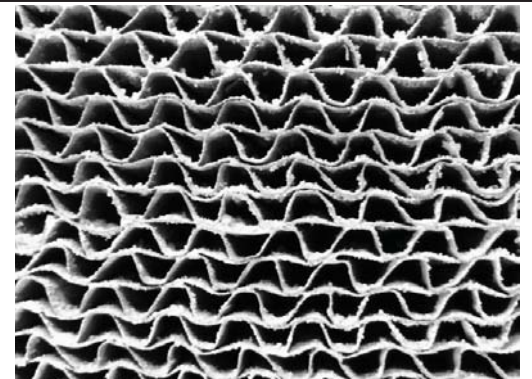

Severe Peeling

**PROBLEM - CATALYST MASKING**

(The catalyst is coated with a layer of fly-ash or soot which prevents catalytic activity)

**Possible Cause:** Accumulation of fly-ash

**Solution:** Brush cooled combustor with a soft-bristled brush or vacuum lightly at least once per burning season.

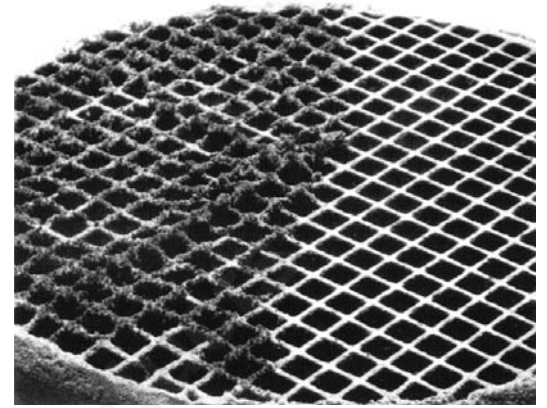
**PROBLEM - THERMAL CRACKING**

**Possible Cause:** Normal operation, as long as the combustor remains intact.

**Solution:** If cracking causes large pieces to fall out, replace the combustor.

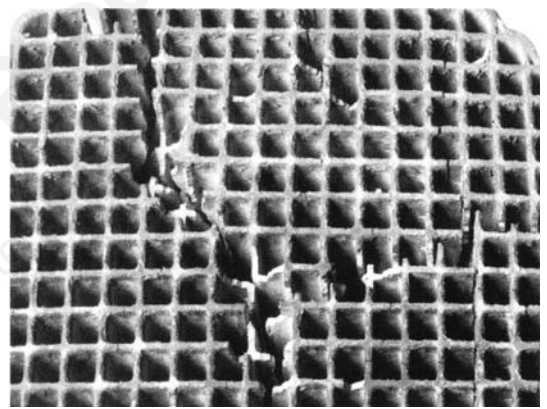
**PROBLEM - MECHANICAL CRACKING**

**Possible Cause:** Mishandling, abuse, or operating without a properly gasket sealed combustor.

**Solution:** Handle with care

**Possible Cause:** Distortion of holding collar.

**Solution:** Combustor should be held firmly in its can. It should slide easily into and out of the holding collar of the stove. If severe cracking has resulted in loss of large chunks of combustor, replace combustor. Also replace any warped stove parts.

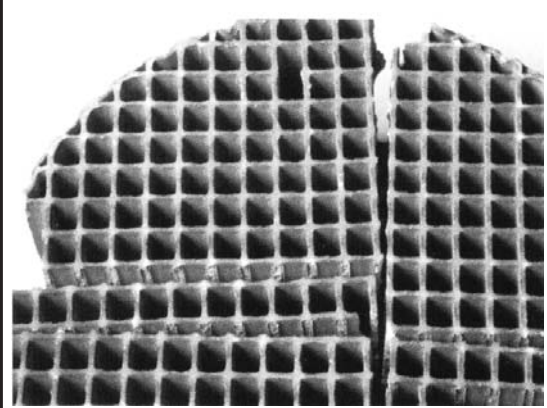
**PROBLEM - CRUMBLING**

**Possible Cause:** Air leaks

**Solution:** Inspect door gasket, see "MAINTENANCE cont." on page 35.

**Possible Cause:** High draft

**Solution:** Do not exceed .06" of water draft.

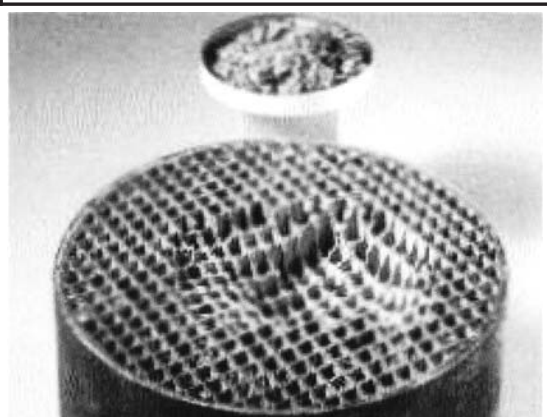

**CATALYTIC COMBUSTOR, REPLACEMENT****BLAZE KING RECOMMENDS YOUR DEALER PERFORM THIS TASK**

The catalytic thermometer on lower left-hand side of the stove should read in the active zone after the stove has been in operation for several hours. If the thermometer's indicator needle does not stay in the active zone, even with a hot fire, over a 7-10 day period of regular use, the combustor may need replacement or cleaning, see "CATALYST MONITORING" on page 27. If the combustor needs replacing then discontinue use of the appliance until the combustor is replaced. If the combustor must be examined or replaced contact your Blaze King dealer.

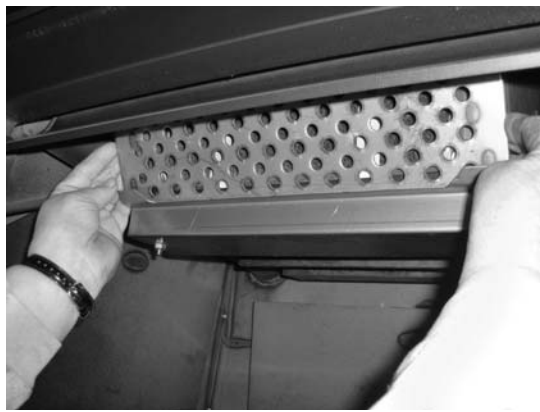

**1.** The removal of a Blaze King Catalytic combustor requires a small flat blade screwdriver or pocket knife. The stove fire must be out for at least 12 hours prior to the removal process. A combustor can reach 1400°F and hold high temperatures for several hours even after the fire is out. After waiting 12 hours, first remove the flame shield by simply lifting the shield off the two tabs at either side.

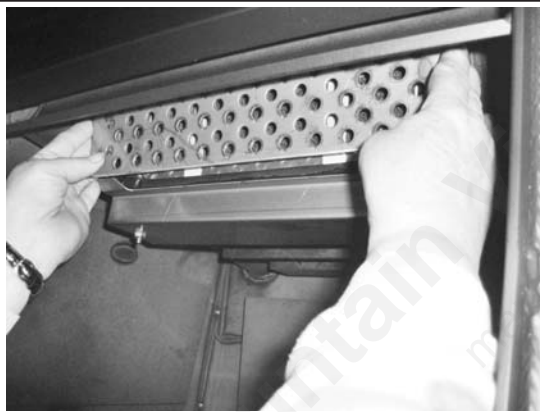

**2.** Once you remove the flame shield, you'll find the combustor. The honeycomb combustor can be made of different materials such as cordierite, mulite or even stainless steel. They are all the same with regard to removal and caution should be taken so as to not drop or damage the combustor. If your combustor has never been cleaned according the manufacturers directions, you may wish to clean the combustor before replacing it with a new combustor, see "CATALYTIC COMBUSTOR CLEANING" on page 27.

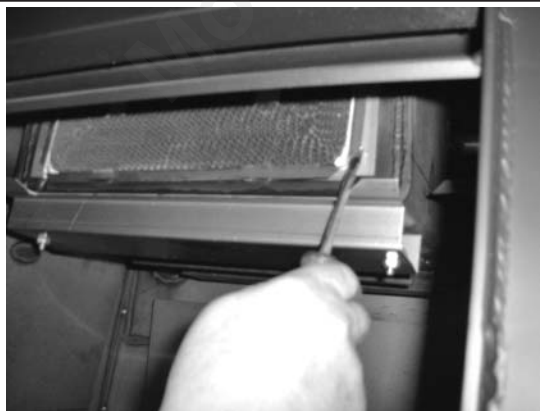

**3.** The combustor has a metal tab across the bottom and on each side of the combustor. Using a flat blade screwdriver or pocket knife blade, slide the blade behind the metal tab and the heavy steel dome of the stove. The dome is the housing that surrounds the combustor. Apply slight pressure until the combustor begins to move forward, about 1/4". Repeat the process on the opposite end tab. By working back and forth the combustor will work free of the dome housing. It is normal for the gasket surrounding the metal band to fall apart during this process. New combustors are shipped with a new gasket.



4. Using the same screwdriver or pocket knife, scrape any old gasket from the surface areas of the dome. The dome is the housing that surrounds the combuster. If you clean your existing combuster, you'll need to order replacement combuster gasket. It is always a good idea to have a spare combuster gasket on hand prior to performing any maintenance. If you purchase a new combuster a new gasket will already be applied to the combuster.

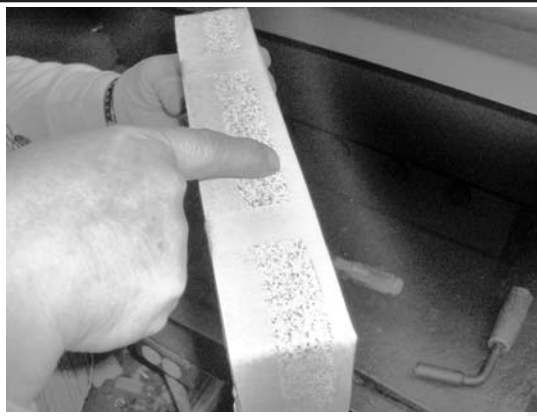

5. This new combuster already has the gasket installed. Note the 1" wide masking tape. This tape will help to keep the leading edge of the gasket from snagging during installation. If you've cleaned your combuster, wrap the combuster gasket as you see here and use the 1" masking tape around the perimeter front and rear. During the first fire the masking tape will burn off and the combuster gasket will swell providing a tight seal. It is this tight seal that improves efficiency and performance. You should never burn your stove without a combuster gasket installed.



6. Since the combuster is only 2" deep, there is ample room to lift the new combuster into place. **REMEMBER TO HAVE THE TAB ACROSS THE BOTTOM EDGE OF THE COMBUSTOR AS IT IS INSTALLED.** Slowly push the combuster in at the top apply even pressure to the left and right corners. This will allow for a better view of the bottom edge for the final fitting. **DO NOT FORCE THE COMBUSTOR INTO THE DOME. TAKE YOUR TIME AND WORK IT INTO PLACE SLOWLY.**

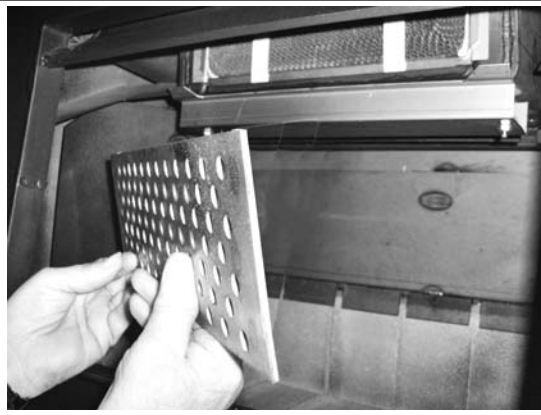

7. Once the combustor is installed completely so that all three tabs are touching the face of the dome, replace the flame shield. Never operate your stove without the flame shield in place. The flame shield will protect the face of the combustor against damages from wood when loading and other possible damages that can occur during the cleaning process.

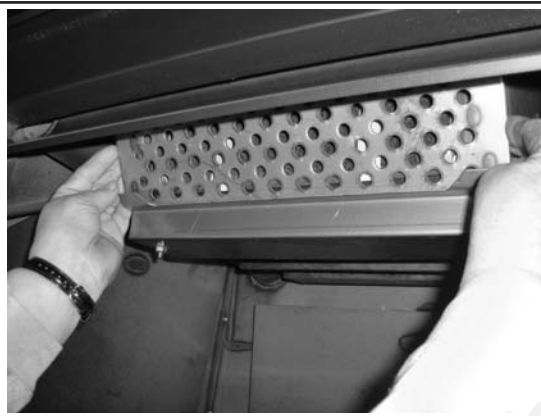

8. The flame shield will rest on the two tabs located on the dome guard and lean slightly forward onto two bolts. Now that your combustor has been installed you can relight your stove. You will continue to receive excellent efficiency and clean burning for years to come. A few reminders, never burn anything other than dry, seasoned cordwood. Burning anything else may contaminate or ruin your new combustor. Also remember to keep your front loading door gasket seal properly adjusted, see "LOADING DOOR TENSION ADJUSTMENT" on page 39. Doing so will improve burn times and extend combustor life span.

The combustor supplied with this heater is a 115.0335 metal combustor. Consult the catalytic combustor warranty also supplied with this wood heater. Warranty claims should be addressed to:

<b>in Canada</b>	<b>in USA</b>
Blaze King Industries / Valley Comfort Systems Warranty Department, 1290 Commercial Way Penticton, BC Canada V2A 3H5, Ph: 250-493-7444	Blaze King Industries Warranty Department, 146A Street Walla, Walla, Washington 99362, Ph: 509-522-2730

**RUN-AWAY OR CHIMNEY FIRE****⚠️ WARNING**

**A CHIMNEY FIRE CAN PERMANENTLY DAMAGE YOUR CHIMNEY SYSTEM. THIS DAMAGE CAN ONLY BE REPAIRED BY REPLACING THE DAMAGED COMPONENT PARTS. CHIMNEY FIRE DAMAGE IS NOT COVERED BY THE LIMITED WARRANTY.**

**CAUSES:**

1. Using incorrect fuel, or small fuel pieces which would normally be used as kindling.
2. Leaving the door ajar too long and creating extreme temperatures as the air rushes in the open door.
3. Improperly installed or worn gaskets.
4. Creosote build up in the chimney.

**SOLUTIONS:**

1. Do not burn treated or processed wood, coal, charcoal, colored paper or cardboard.
2. Be careful not to over fire the appliance by leaving the door open too long after the initial start-up.
3. Replace worn, dried out (inflexible) gaskets.
4. Have your chimney cleaned regularly.

**WHAT TO DO IF A RUN-AWAY OR CHIMNEY FIRE STARTS:**

1. Close the draft fully (lowest position) by shutting off thermostat, and make sure firebox is closed tightly.
2. Call the local fire department.
3. Examine the chimney, attic and roof of the house, to see if any part has become hot enough to catch fire. If necessary spray with a fire extinguisher or water from a garden hose.
4. Do not operate the appliance again until you are certain the chimney has not been damaged.

**CREOSOTE FORMATION AND REMOVAL**

When wood is burned slowly, it produces tar and other organic vapors which combine with expelled moisture to form creosote. These vapors condense in the relatively cooler chimney flue of a slow burning fire and when ignited, make an extremely hot fire. Check your chimney for creosote and soot regularly, until a safe frequency for cleaning is established. The chimney connector and chimney should be inspected regularly during the heating season to determine if a creosote build up has occurred. Be aware that the hotter the fire, the less creosote is deposited.

If accumulation is excessive, clean the chimney. You may want to call a professional chimney sweep to clean it. Both the chimney and the appliance have to be cleaned at least once a year or as often as necessary. Have a clearly understood plan to handle a chimney fire.

### CHIMNEY MAINTENANCE

The most efficient method to sweep the chimney is using a hard brush. Brush downwards so soot and creosote residues will come off the inner surface and fall to the bottom of the chimney where they can be removed easily. The chimney must be checked regularly and if creosote has accumulated, it must be removed without delay. Cleaning on a regular basis should be sufficient during the coldest months. **ENSURE THE BYPASS DOOR IS OPEN PRIOR TO CLEANING THE CHIMNEY SO THE SOOT AND CREOSOTE FALLS INTO THE FIREBOX.**

Chimney / Flue Inspection:

1. The chimney should be inspected regularly during the heating season.
2. If possible, the chimney should be dismantled and cleaned.
3. The chimney should be inspected for possible damage.
4. If it is in good condition, put the chimney back in place; otherwise, it must be replaced.

### FIRE EXTINGUISHERS AND SMOKE DETECTORS

All homes with a solid fuel burning appliance should have at least one fire extinguisher in a central location, known to all, and at least one smoke detector in the room containing the appliance. If it sounds an alarm, correct the cause but do not de-activate or relocate the smoke detector.

### ASH REMOVAL

This appliance is required to be cleaned frequently because soot, creosote and ash may accumulate. Wait until the appliance is fully cooled off before the removal of ashes. **ALWAYS REMOVE THE ASH BUCKET IMMEDIATELY AFTER FILLING.** Ashes should be removed any time they come within one inch of the door opening. It is not necessary or advisable to completely remove all of the ashes when cleaning this appliance. Wood burns best in a bed of ashes 1/2" thick. Ashes should be placed in a metal container with a tight fitting lid. The closed container of ashes should be placed on a noncombustible floor or on the ground (outside), well away from all combustible materials, pending final disposal. If the ashes are disposed of by burial in soil or otherwise locally dispersed, they should be retained in the closed container until all cinders have thoroughly cooled. Other waste shall not be placed in this container.

### WARNING

**NEVER STORE HOT ASHES IN A GARAGE OR BASEMENT. HOT ASHES WILL GENERATE CARBON MONOXIDE AND / OR FLAMMABLE GASES. THESE GASES MAY CAUSE SUFFOCATION AND POSSIBLE DEATH.**

### LOADING DOOR GASKET INSPECTION

Inspect the door gasket for physical deterioration, missing sections or obvious leakage. The appliance front should make a groove in the gasket material - one side of the groove (toward the inside) will often be dark or black, and the other side (toward the outside) should be light or white. Dark smudges on the outside of the groove may indicate an air leak. If the groove is very shallow or missing, or if there is a heavy ash or creosote deposit along the bottom edge of the gasket, it may need to be replaced. Frayed or broken gasket material, or a gasket that is hard and unyielding, will also indicate need for replacement. Any time a piece of gasket is missing or is broken anywhere, the entire gasket must be replaced.

To check the gasket further, wait until the appliance is cooled and insert a piece of paper (a dollar bill will work) into the door opening and close and latch the door. Obvious resistance should be felt when pulling the paper out. Repeat this check several times around the perimeter of the door.

### LOADING DOOR GASKET REPLACEMENT

#### **BLAZE KING RECOMMENDS YOUR DEALER PERFORM THIS TASK**

1. If the door gasket is to be replaced, be sure you have Blaze King 7/8" fiber glass door gasket ready to re-install, as well as high temperature adhesive. See your Blaze King dealer.
2. Be sure the fire is out and the stove has cooled down. The door does not have to be removed from the stove.
3. With a pair of pliers, pull the old door gasket out of the channel and dispose of it.
4. Thoroughly clean out the channel so the new silicone adhesive will adhere and the gasket will fit smoothly.
5. Dry fit the new gasket first to ensure proper fit. Do not stretch or cut the gasket. Distribute the gasket evenly around the frame.
6. Run a small bead of a high temperature silicone adhesive along the center of the channel. **DO NOT USE HOUSEHOLD SILICONE CAULKING.** High temperature silicone may be obtained from wood stove dealer.
7. Start the new gasket in the lower right corner. Do not stretch or cut the gasket. Distribute the gasket evenly around the frame.
8. Allow the adhesive to dry before closing the loading door. The loading door tension may need to be adjusted, see "LOADING DOOR TENSION ADJUSTMENT" on page 40.
9. Check the fit of the door gasket. Insert a narrow strip of paper into the door opening and close and latch the door. Obvious resistance should be felt when pulling the paper out. Repeat this check several times around the perimeter of the door. If no resistance is felt, adjust door latch catch, see "LOADING DOOR TENSION ADJUSTMENT" on page 40.
10. A tight sealing door extends the burn times & protects the combustor.

**BYPASS DOOR GASKET RETAINER REPLACEMENT #Z2022**

1. Remove flame shield. (see CATALYTIC COMBUSTOR REPLACEMENT step 1)
2. Remove the combustor. (see CATALYTIC COMBUSTOR REPLACEMENT step 2-4)
3. Remove hanging smoke baffle.
4. Open bypass door (slide it all the way forward) and unthread/remove the 1/4-20 bolt and washer that fastens the bypass door to the bypass rod bracket. Remove the bypass door through the combustor opening once detached.

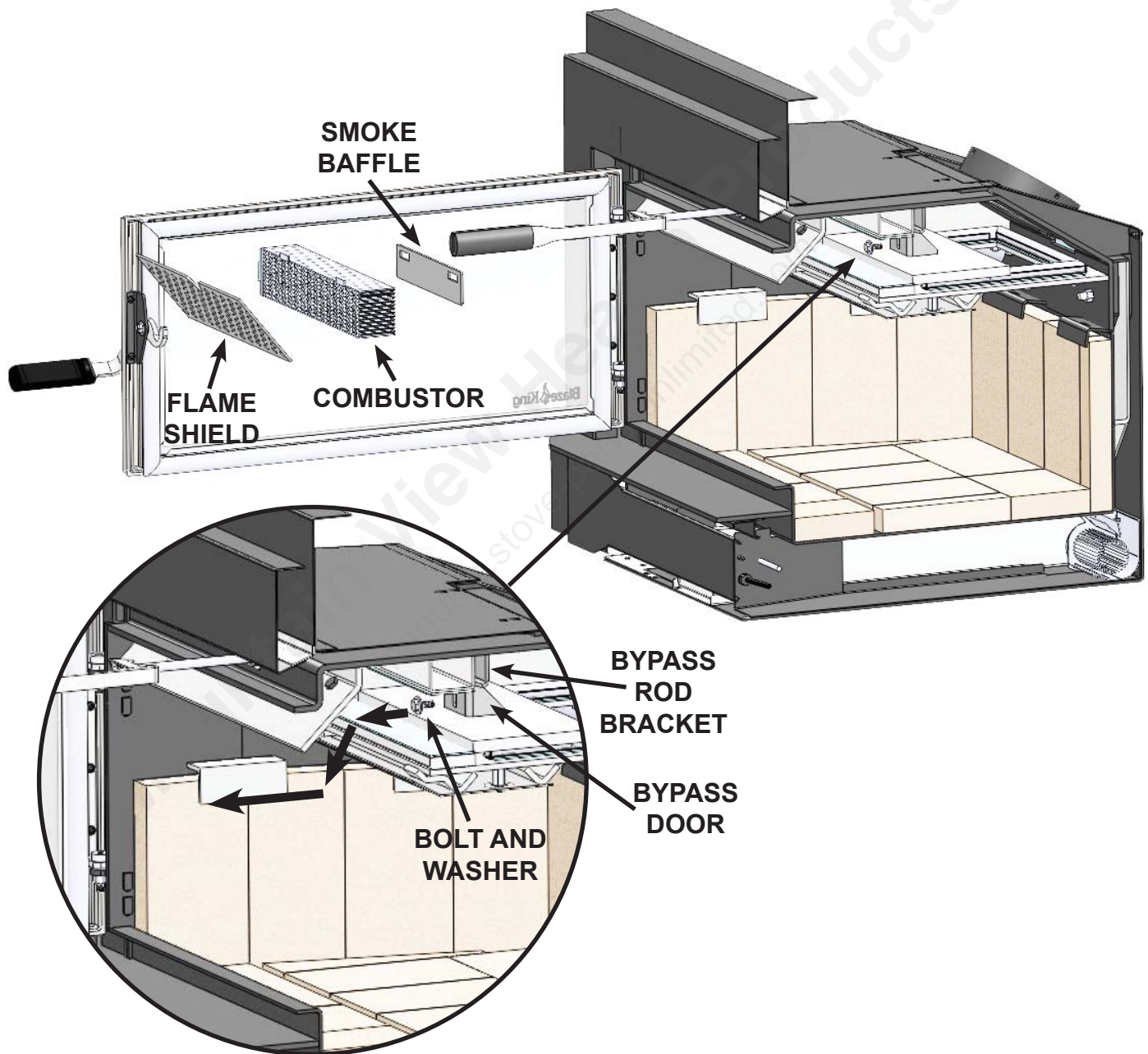

5. Remove the two 1/4-20 bolts and washers that hold the dome guard in place, be sure to support the dome guard during this process as it will come loose. Once the dome guard is removed, unthread the two 1/4-20 coupling nuts that spaced the dome guard from the dome bottom.

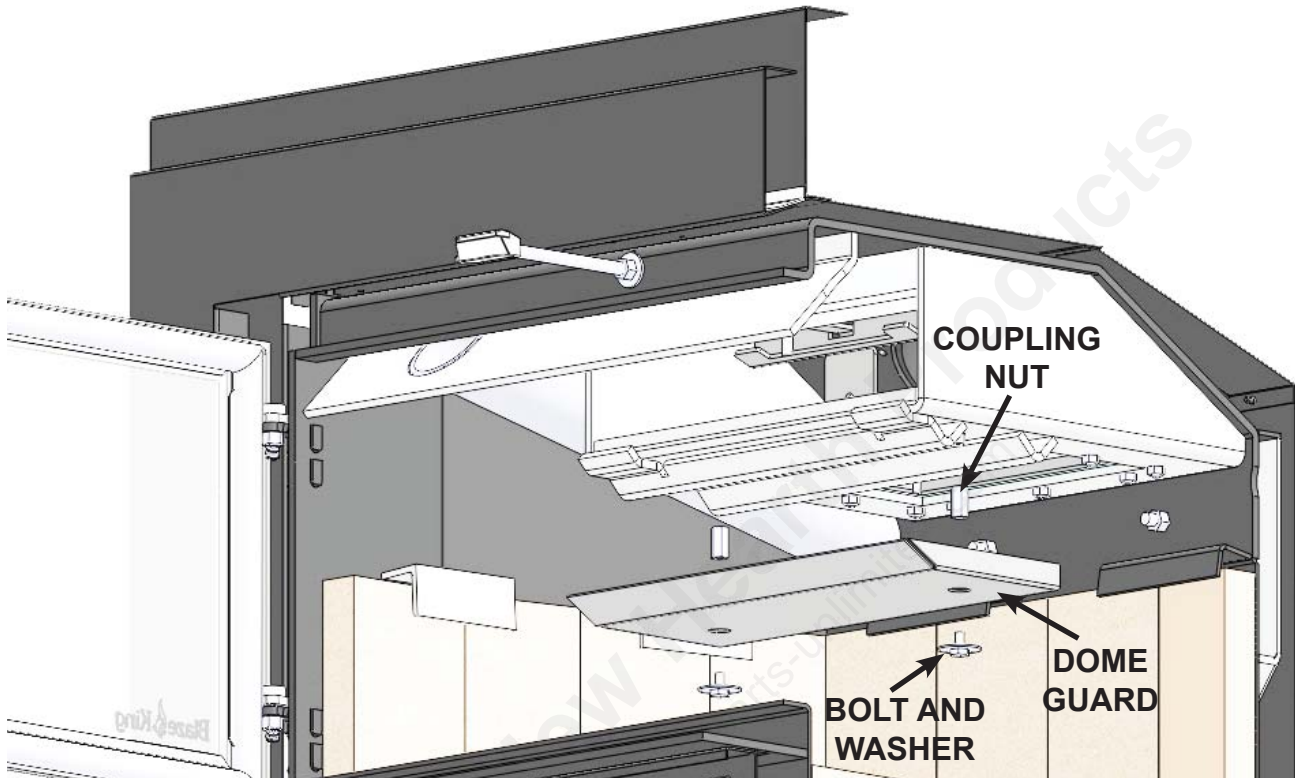

6. Remove the twelve remaining 1/4-20 nuts from the dome bottom. Lift the bypass door gasket retainer assembly upwards (enough to clear the threaded posts from the dome) and remove through the combustor opening. Once removed, ensure all debris is cleared from the inner surface of the dome.

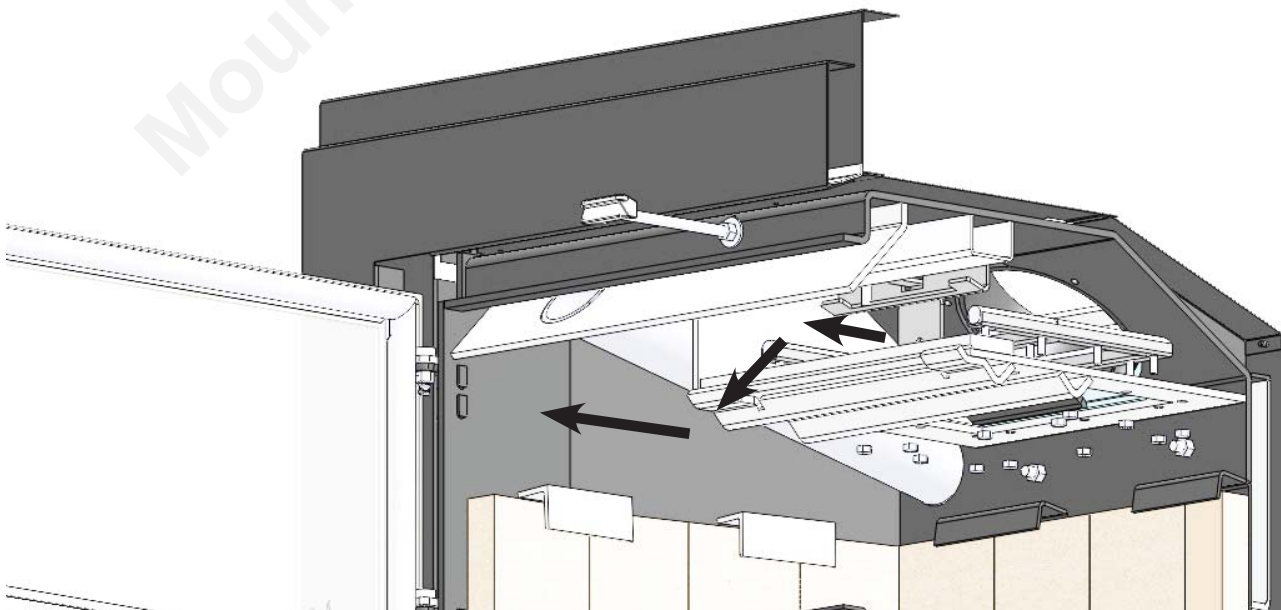

7. Once the inner dome surface has been cleared, insert the new bypass door gasket retainer assembly and follow the above instructions in reverse to ensure complete install. Ensure that 1/8" ceramic paper is in between the gasket retainer assembly and inner dome surface. Also ensure that all nuts are completely fastened up to the dome bottom. When tightening the 1/4-20 bolt through the bypass door into the bypass rod bracket, do not over tighten. Simply finger tighten the bolt as this allows the bypass door to move down as the gasket begins to seat after the first few fires.
8. When reinstalling the combustor, ensure it has been rewrapped with new expanding gasket that was supplied with the replacement kit. Do not install combustor without gasket.

### DOOR GLASS GASKET INSPECTION

When the appliance is cold, hold the glass by placing the palm of each hand on either side of the glass. Press firmly and try to move the glass. If the glass moves the door glass retainers may need to be tightened or the door glass gasket may need to be replaced.

1. Inspect the door glass gasket. If the gasket is frayed or missing sections replace the gasket.
2. Inspect the glass retainers and ensure the screws holding the retainers in place are tight. Hand tighten plus 1/4 turn. Do not over tighten.

### DOOR GLASS GASKET REPLACEMENT

#### BLAZE KING RECOMMENDS YOUR DEALER PERFORM THIS TASK

1. You will require Blaze King glass gasket and Blaze King door gasket. Please see your Blaze King dealer.
2. Remove the old glass gasket.
3. Starting at the corner opposite of the "Blaze King" logo, carefully wrap the gasket around the edges, pressing firmly onto the sides of the glass with the gasket centered on the edge. Finish the wrapping with a 1/2" overlap. Ensure the thickness of the gasket remains consistent and uniform.
4. Install glass with the "Blaze King" logo to the lower left corner of the door. Install the glass retainers with original fasteners. Ensure the glass is parallel to the frame and tighten the fasteners evenly.
5. Follow steps on page 38, "LOADING DOOR GASKET REPLACEMENT".



BLAZE KING LOGO

### DOOR GLASS, REPLACEMENT

Should the door glass become broken and/or damaged, please see your Blaze King dealer for replacement and installation. Replace only with ceramic glass, 5 mm. thickness. Follow steps 4 and 5 in "DOOR GLASS GASKET REPLACEMENT" to install the new glass.

### DOOR GLASS, CLEANING

The best way to keep the glass clean is to leave the appliance on high burn for a period of time after each reloading. The moisture which is driven from a new load of wood contributes much of the creosote on the inside of the glass. Removing that moisture at the beginning of the burn cycle helps to keep the glass clean. Leaving the thermostat on a higher setting for 30 minutes to an hour before turning to low for an overnight burn will also help. Heavier deposits may require hand cleaning. Manual glass cleaning should be done when the appliance and glass are cool. **DO NOT CLEAN THE GLASS WHILE IT IS HOT. WARNING: Do not use abrasive cleaners to clean the glass.** Use a soft cloth. After using any cleaner, thoroughly rinse the glass with water to remove any deposits left by the cleaner. Failure to remove all traces of glass cleaner will result in the glass cleaner residue baking on. This residue may be very difficult to remove.

**LOADING DOOR TENSION ADJUSTMENT**

1. Open the door.
2. To tighten the door tension use a 7/16" wrench to loosen the two nuts on the latch cover. Slide the latch cover towards the back of the stove and tighten nuts. (Fig. 13) Repeat paper test (see "LOADING DOOR GASKET INSPECTION" on page 35).



Fig. 13

**⚠ WARNING**

DO NOT OPERATE THIS WOOD STOVE IF THE DOOR GASKET IS MISSING OR DAMAGED DANGEROUS OVER FIRING CAN OCCUR WHICH CAN DAMAGE THE APPLIANCE OR IGNITE CREOSOTE IN THE CHIMNEY, POSSIBLY CAUSING A HOUSE FIRE. IF ANY PART OF THE WOODSTOVE OR FLUE SYSTEM IS GLOWING THE STOVE IS BEING OVER FIRED.

**LOADING DOOR HINGE ADJUSTMENT**

1. Open the door to 90°.
2. Hold bottom nuts using a 9/16" wrench. Use a 1/4" Allen head screwdriver to back nuts off the bolts. (Fig. 14)
3. Remove the door by lifting up and out.

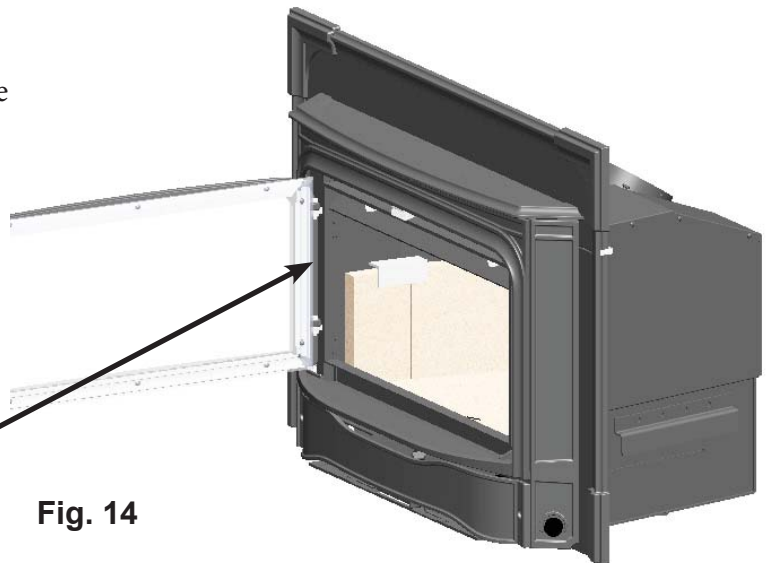
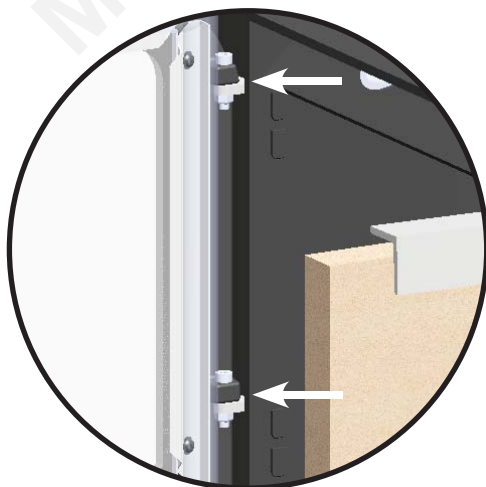

Fig. 14



4. Loosen the four door hinge nuts using a 7/16" wrench. Slide door hinges in to tighten door seal and out to loosen door seal. (**Fig. 15**)
5. Put door back on using nuts and bolts.
6. Repeat paper test (see "LOADING DOOR GASKET INSPECTION" on page 35).

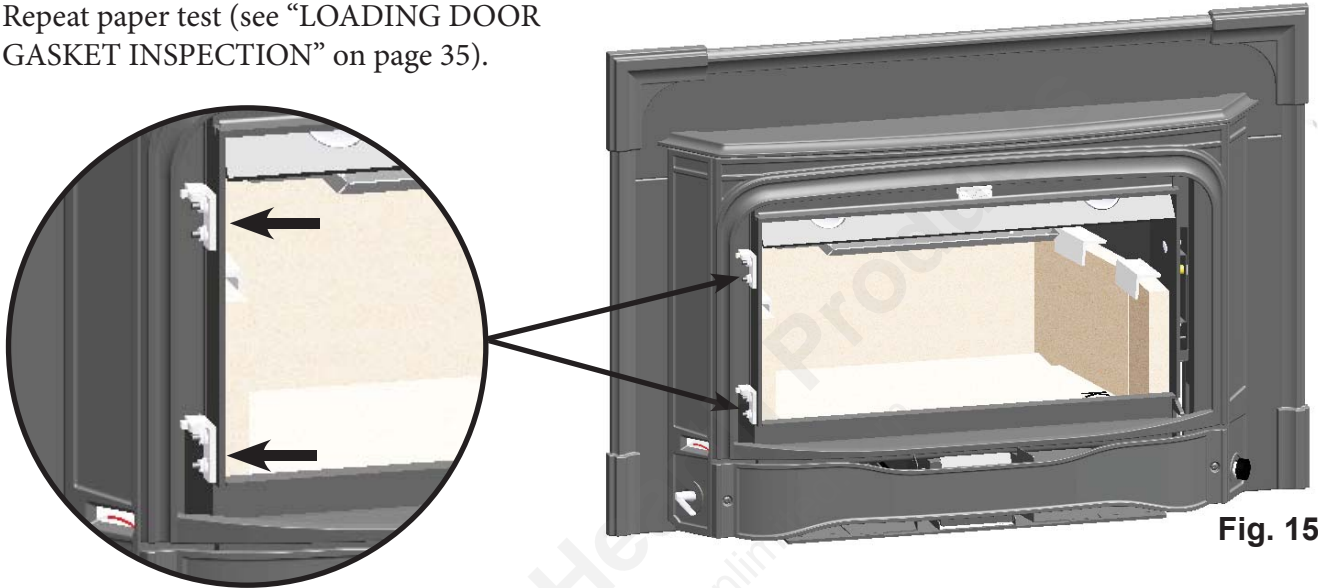

Fig. 15

#### FAN ASSEMBLY

Routine maintenance of the fan assembly on the side of the stove is not required. However, should it become necessary to replace an individual fan or rheostat, contact your local dealer.

#### THERMOSTAT

This wood heater thermostat has a manufacturer-set minimum low burn rate that must not be altered. It is against federal regulations to alter this setting or otherwise operate this wood heater in a manner inconsistent with operating instructions in this manual. If the thermostat malfunctions contact your dealer for replacement by a qualified installer.

Your Blaze King is designed to allow a wide selection of heat output levels. If you begin to lose control of the amount of heat the stove is emitting, determine the cause early so that major problems may be avoided.

The six major needs of a well-controlled fire are:

1. Knowledgeable operator.
2. Adequate air supply.
3. Firewood of good quality and proper size.
4. Catalytic combustor in good condition.
5. Clean chimney, properly sized and installed.
6. Door gasket tight and firm.

Considering all of the above, number one is the most important for safe and efficient operation of any woodstove. Please study the operation instructions carefully. Consult your BLAZE KING dealer or call the Customer Service Department at Blaze King in the U.S.A. at 509-522-2730 or in Canada at 250-493-7444 if you have any questions not answered in this manual.

All of the six above mentioned needs are interrelated. A deficiency in any one will affect all of the others. If you encounter a problem, determine the source of the problem and then follow-up by checking the other needs as possible contributing factors.

<b>PROBLEM: Chimney Fire</b>	
<b>CAUSE</b> Act immediately regardless of cause	<b>SOLUTION</b> Turn the thermostat to lowest setting, check loading door to be sure it is tightly closed. <b>Call Fire Department.</b>
After the fire is out, have your chimney and flue connector inspected by a certified chimney sweep. A damaged masonry chimney should be repaired or rebuilt. A prefabricated chimney (factory built) that is damaged should be replaced. Any damage to the flue connector should be corrected before the system is used again.	
Possible causes of a chimney fire, and remedies for those causes, can be found further in this section: "Excessive Creosote Formation", and "Spots of Creosote Accumulation in Chimney or Flue Connector".	

<b>PROBLEM: Not enough heat.</b>	
<b>CAUSE</b> Green or wet wood. Not enough fuel in stove.	<b>SOLUTION</b> Use seasoned wood. Don't be afraid to FULLY load the stove. A FULL load of wood won't burn any hotter than the thermostat is set.
Obstruction in chimney or cap screen. Combustor plugged or coated.	Remove obstruction. See "COMBUSTOR, TESTING" See "COMBUSTOR, CLEANING"
Combustor not functioning.	See "COMBUSTOR, TESTING". If needed, replace combustor, See "COMBUSTOR, REPLACING".
Thermostat set too low.	Raise thermostat setting.
Thermostat not operating properly.	Consult your Blaze King dealer.
Poor draft caused by an oversize flue	Measure draft with Manometer. See "CHIMNEY DRAFTS" Consult your Blaze King dealer or a chimney sweep.
Strong, gusting winds causing downdraft in chimney	Install wind-resistant chimney cap. Directional caps may not stay freely rotating. If you have a directional cap, check it frequently.
Tightly sealed house, inadequate air supply.	Slightly open a window, near the stove.
Reloading too much wood on top of too few coals.	Allow a larger bed of coals to build up.

<b>PROBLEM: Too much heat.</b>	
<b>CAUSE</b>	<b>SOLUTION</b>
By-Pass door left open.	Close the by-pass door.
Thermostat set too high.	Lower thermostat setting.
Loading door gasket leaking, admitting excess air into firebox.	Replace door gasket and/or adjust door. See "GASKET INSPECTION"
Excessive draft in the chimney.	Measure draft with a Manometer. See "DRAFTS". Consult your Blaze King dealer or a chimney sweep. Install a cap.
Thermostat not operating properly.	Consult your Blaze King dealer.
Wood is too small.	Use larger pieces.
<b>PROBLEM: One or both fans will not run, or there is no adjustment for fan speed.</b>	
<b>CAUSE</b>	<b>SOLUTION</b>
Fans mounted improperly.	Check that fan blade's not touch edges of hole.
Fan speed control.	Consult your Blaze King dealer for replacement.
<b>PROBLEM: Fans minimum speed too fast or maximum speed too slow.</b>	
<b>CAUSE</b>	<b>SOLUTION</b>
Fan speed control out of adjustment.	Consult your Blaze King Dealer.
<b>PROBLEM: Excessive creosote formation in chimney and chimney Connector.</b>	
<b>CAUSE</b>	<b>SOLUTION</b>
By-pass door left open.	Close by-pass door.
By-pass door not sealing tightly.	Inspect by-pass door and seal for warping. Ash or creosote buildup may occur on door or seat. With stove cold scrape and vacuum area around by-pass. Be sure all mating steel surfaces are clean and smooth.
Improper operation.	Check thermostat setting and operating procedures. See "THERMOSTAT & OPTIMAL THERMOSTAT SETTING"
Wood too green or wet.	Use seasoned wood. Use a moisture meter to confirm.
Catalytic combustor not operating properly.	Inspect the combustor. See "CATALYTIC COMBUSTOR, TESTING"
Poor draft caused by an oversize or short flue, etc.	Measure draft with Manometer. See "DRAFTS". Consult your Blaze King dealer or a chimney sweep.
Chimney too cold or poorly insulated.	Upgrade chimney system. Consult your Blaze King dealer or a chimney sweep.
<b>PROBLEM: Catalytic combustor thermometer (on top of stove) does not go into "Active" zone, or does not stay there for long. (Fans must be in "off" position for 10 minutes prior to checking)</b>	
<b>CAUSE</b>	<b>SOLUTION</b>
Improper operation.	Check thermostat setting and operating procedures. See "THERMOSTAT & OPTIMAL THERMOSTAT SETTING"
Obstruction in chimney or cap.	Clean chimney, remove obstructions.
Faulty combustor thermometer.	Replace thermometer and Recheck combustor operating Temperature.
Wood too green or wet.	Use seasoned wood.

Combustor plugged or coated.	Clean combustor. See "CATALYTIC COMBUSTOR TESTING"
Combustor not functioning.	Check and test combustor. If needed replace combustor. See "CATALYTIC COMBUSTOR, REPLACING"
Thermostat not operating properly.	Consult your blaze King Dealer.
By-pass door leaking or not closing completely.	Inspect and clean area around by-pass doors. Adjust or replace gasket if necessary. Consult your Blaze King Dealer.

**PROBLEM: Spots of creosote accumulation in chimney or chimney connector.**

<b>CAUSE</b> Air leaks in chimney or chimney connector.	<b>SOLUTION</b> Inspect chimney and / or chimney connector. Repair or replace as necessary. Check to be sure that the chimney connector is installed correctly.
--	--

**CAUTION: a leaking chimney connector is a fire hazard and demands immediate attention.**

Poor draft caused by an oversize flue, single wall pipe, to many elbows, etc.	Measure draft with Manometer. See "DRAFTS". Consult your Blaze King dealer or a chimney sweep.
---	--

**PROBLEM: Door glass quickly becomes coated with creosote.**

<b>CAUSE</b> Low thermostat setting or lowering the thermostat setting too far, too quickly.	<b>SOLUTION</b> Turn the thermostat to the warmest setting during the first 20-30 minutes or until the fire is well established after each reloading.
Poor draft caused by an oversize or short flue, etc.	Measure draft with Manometer. See "DRAFTS". Consult your Blaze King dealer or a chimney sweep.
Obstruction in chimney or cap screen.	Remove obstruction. Clean chimney and/or cap screen.
Strong, gusting winds causing downdraft in chimney.	Install wind-resistant chimney cap.
Tightly sealed house, inadequate air supply.	Open a window, slightly, near the stove.
Burning poorly seasoned wet wood, or wood with high pitch content.	Use seasoned wood with low pitch content, such as some types of pine.

**PROBLEM: The combustor temperature cannot be controlled. Turning the thermostat down often makes the combustor temperature go up.**

<b>CAUSE</b> Turning the thermostat down, particularly in the first half of the burn cycle, causes the fire to emit more smoke, which is fuel for the combustor. The combustor temperature therefore climbs for up to several hours. This is normal, and is of no concern. As long as only the combustor temperature is elevated, there is nothing to worry about.
---

**PROBLEM: Smoke spills from door opening when loading fuel**

<b>CAUSE</b> Spark arrestor screen on cap plugged.	<b>SOLUTION</b> Clean spark arrestor screen to bare metal wire.
Chimney too cold.	Make certain insulated liner is used in installation.
Not enough vertical rise.	Make certain sufficient vertical rise is observed.
Chimney not drafting.	Turn thermostat to highest setting, open bypass, leave loading door closed and wait 5-10 minutes to increase chimney or flue temperature.

# REPLACEMENT PARTS

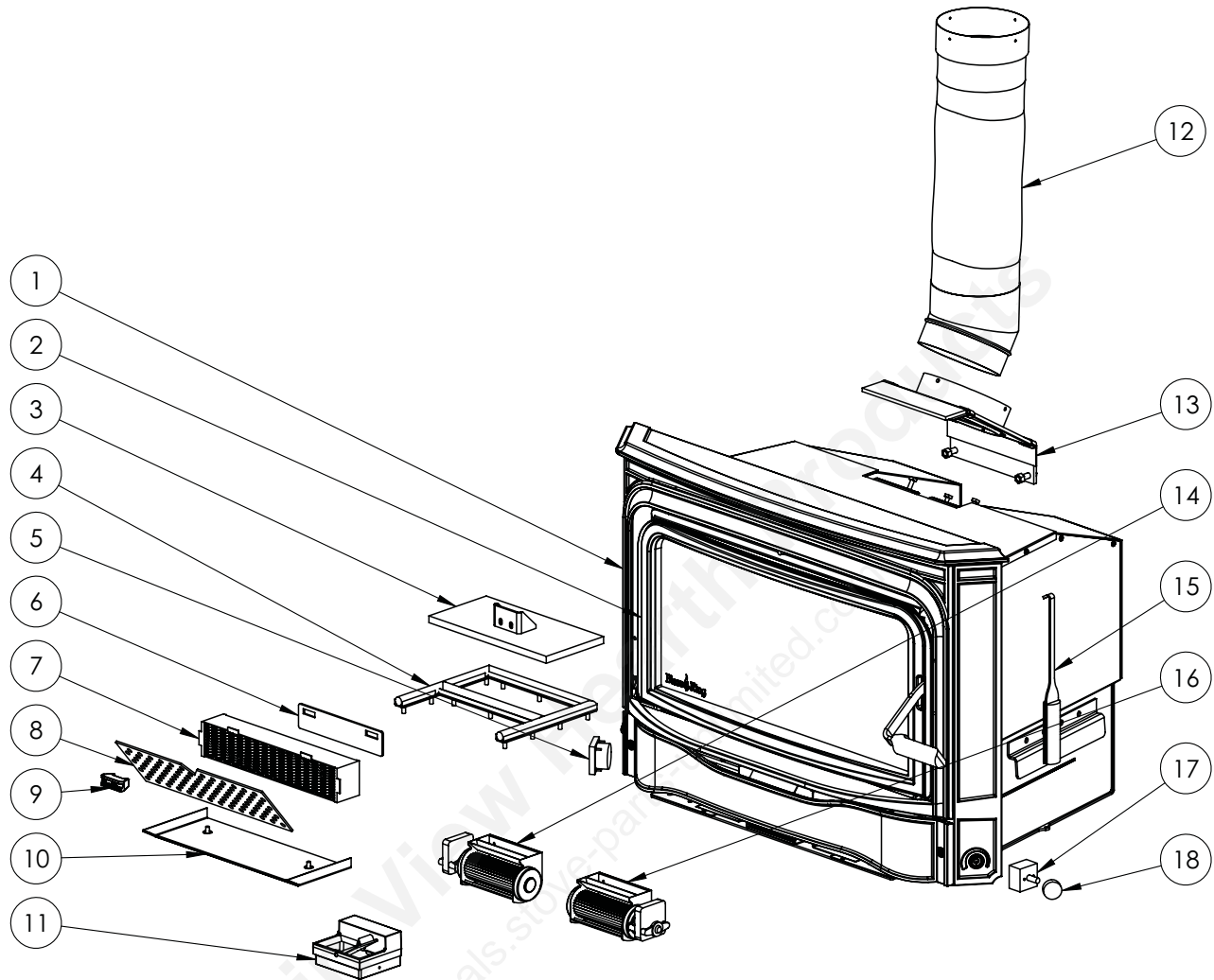

ITEM NO.	PART NUMBER	DESCRIPTION	QTY.
1	Z2011	AF25 CAST ASSEMBLY	1
2	Z2010	AF25 CAST DOOR ASSEMBLY	1
3	Z2019	25 BYPASS DOOR ASSEMBLY	1
4	Z2022	25 BYPASS GASKET RETAINER ASSEMBLY	1
5	120.0800	ANALOG CAT THERMOMETER	1
6	2049	SMOKE BAFFLE	1
7	Z0335	METAL COMBUSTOR	1
8	2030	FLAME SHIELD	1
9	110.2060	CAST BYPASS LATCH	1
10	Z2050	DOME GUARD ASSEMBLY	1
11	Z2030	FLAME SHIELD	1
12	225.2054	25i FLUE EXTENSION	1
13	Z2015	REMOVABLE FLUE COLLAR ASSEMBLY	1
14	150.0710.L	FAN CROSS FLOW LEFT	1
15	Z2052	BYPASS HANDLE ASSEMBLY	1
16	150.0710.R	FAN CROSS FLOW RIGHT	1
17	145.0136	RHEOSTAT	1
18	220.0137	RHEOSTAT KNOB BLACK SILVER LINE	1

## Z2010 AF25 CAST DOOR

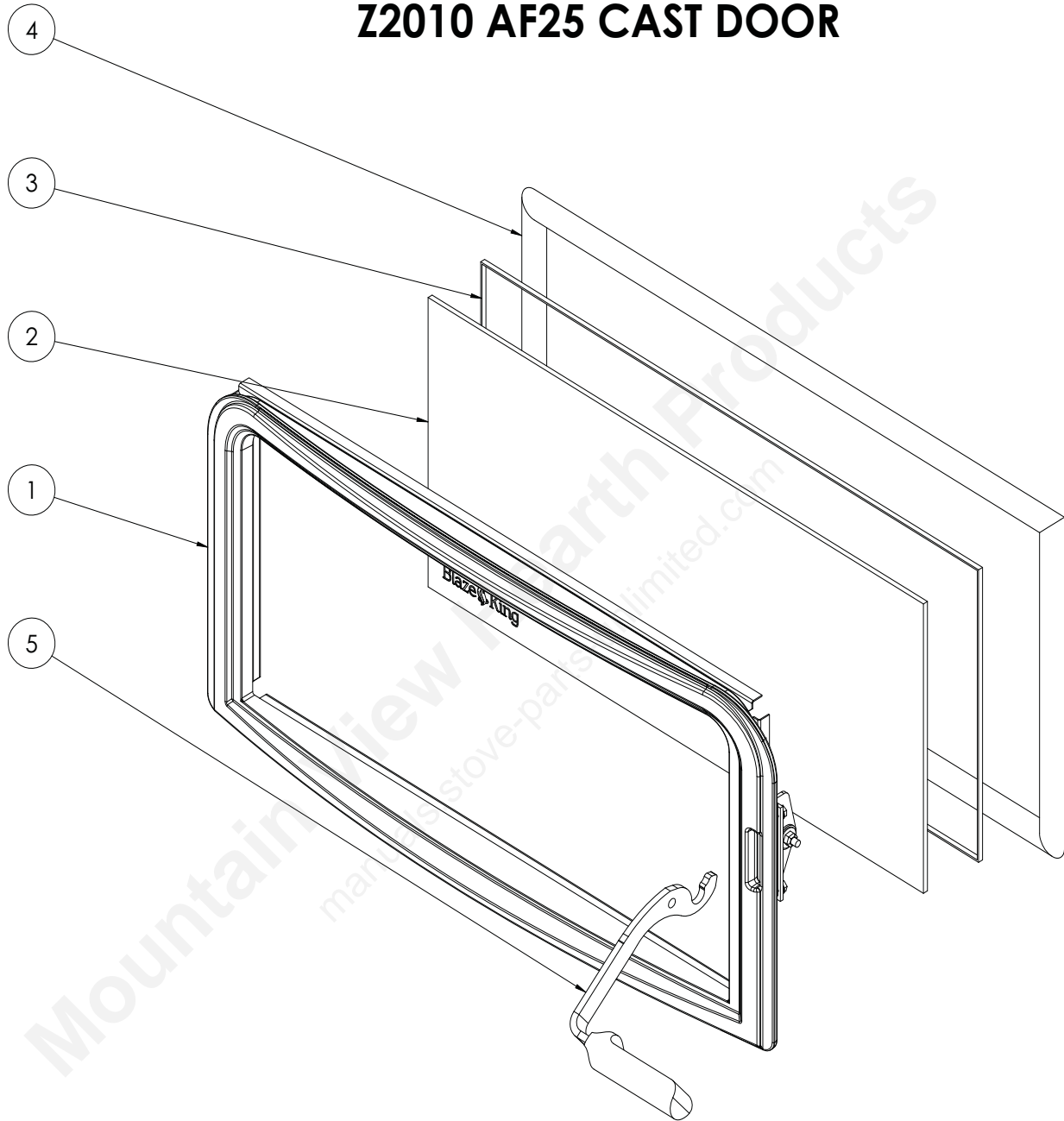

ITEM NO.	PART NUMBER	DESCRIPTION	QTY.
1	110.2010	AF25 CAST DOOR	1
2	130.0270	GLASS CERAMIC 5MM 25i	1
3	155.0254.AS	GASKET 1/8 X 3/4 W/PSA SPEC / FT	6.65
4	155.0186	GASKET 7/8 RND BLK MID / FT	7
5	2044	SC25 DOOR HANDLE	1

### Refractory Brick Layout

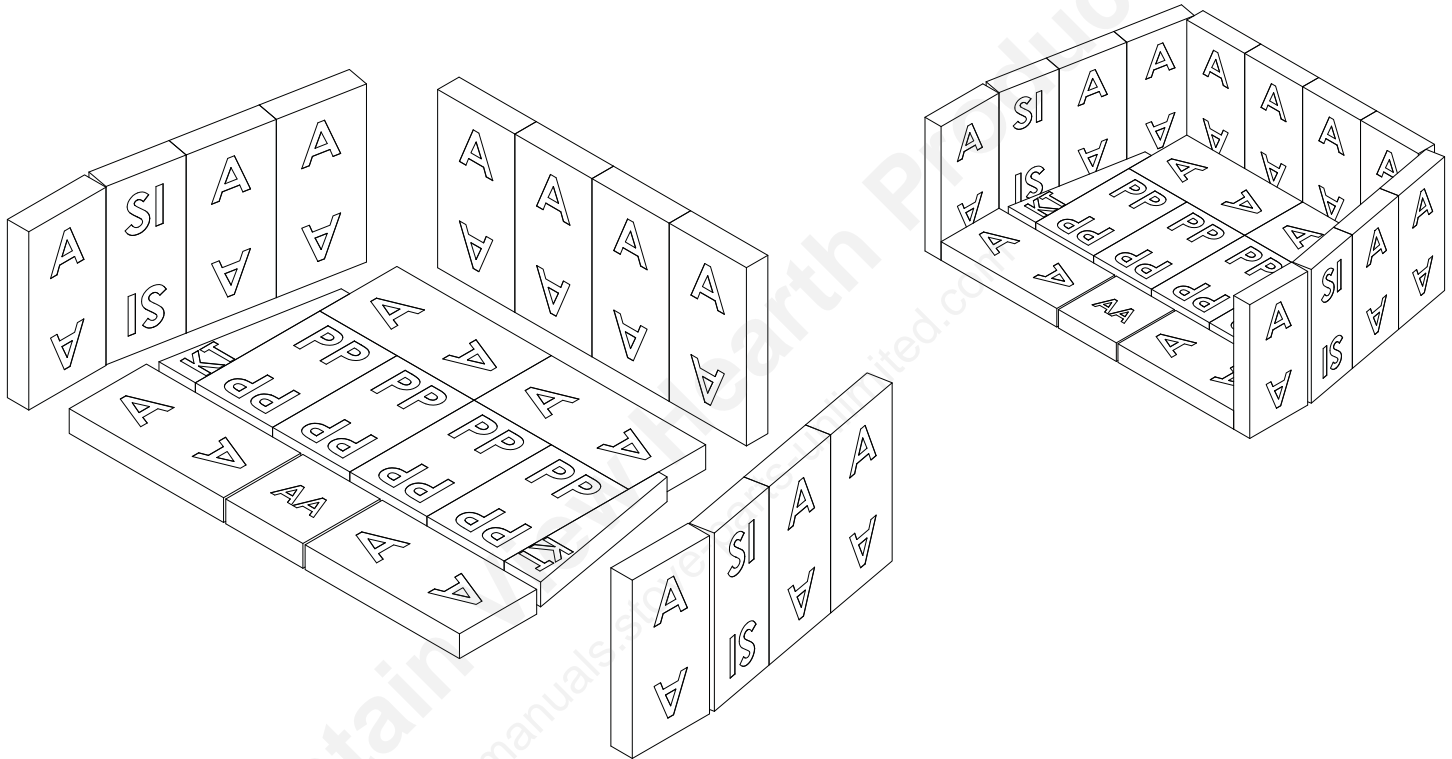

ITEM NO.	PART NUMBER	QTY.
1	A Size Brick	14
2	AA Size Brick	1
3	KT Size Brick	2
4	PP Size Brick	4
5	SI Size Brick	2

**BLAZE KING WOOD LIMITED WARRANTY**

Blaze King and Valley Comfort’s respective brands extend the following warranty for wood fired appliances purchased from an authorized Blaze King / Valley Comfort dealer and installed in the United States of America or Canada. Warranty starts with date of purchase by the original owner (End User) except as noted for replacement parts.

Warranty Period		Components Covered	
Parts	Labor	Wood	
1 Year		X	All parts, materials and surface finishes (flaking and peeling) Subject to Conditions, Exclusion, and Limitations listed.
2 Years		X	Fan assemblies and motors, thermal sensors, catalytic thermometer, bi-metallic thermostat assembly, door handle metal components.
5 Years	2 Years	X	Firebox & Heat Exchanger, Bypass Door Steel Components
6 Years		X	Catalyst Combustor ( see Conditions, Exclusions, and Limitations)
1 Year		X	Other Replacement Parts
See Conditions, Exclusions, and Limitations			

**Blaze King Wood Limited 5 Year Warranty**

Blaze King is the manufacturer of the Blaze King line of heating products. At Blaze King, our commitment to the highest level of quality and customer service is the most important thing we do. Each Blaze King appliance is built on a tradition of using only the finest materials and is backed by our limited warranty to the original purchaser. With Blaze King, you're not just buying a appliance; you're buying a company with years of unequalled performance and quality.

**Limited Six (6) Year Warranty:**

The CATALYTIC COMBUSTOR is under warranty by Blaze King for six (6) years from the date of original retail purchase. The purchaser shall pay the following share of the then current retail price for the combustor: The first three (3) years no charge, 4th year 60%; 5th year 70%, 6th year 80%. The Combustor must be returned to your dealer along with a completed COMBUSTOR FAILURE REPORT and original proof of purchase document.

**Limited (5) Year Warranty:**

Under this warranty, Blaze King covers the appliance body and accessories against defects in materials and workmanship, for part repair or replacement for the first five (5) years \*\*\* to the original purchaser. This Warranty covers: All Steel firebox components against defects in material and workmanship. Please see the exclusions and limitation section below as certain restrictions and exclusions apply this warranty.

**Limited Two (2) Year Warranty:**

Under this warranty, Blaze King covers, fan assemblies , modular thermostat and door handle steel components against defects in materials and workmanship, for part repair or replacement and limited labor for the first two (2) years to the original purchaser. Please see the exclusions and limitation section below as certain restrictions and exclusions apply to this warranty.

**Limited One (1) Year Warranty:**

Under this warranty, Blaze King covers all parts and materials against defects in materials and workmanship including exterior paint finishes, for part repair or replacement and limited labor for the first year to the original purchaser. Please see the exclusions and limitation section below as certain restrictions and exclusions apply to this warranty.

**How the Warranty Works**

1. All warranties by the manufacturer are set herein and no claim shall be made against the manufacturer on any oral warranty or representation. All claims under this Limited Warranty must be made in writing by your dealer.
2. Any appliance or part thereof that is repaired or replaced during the Limited Warranty period will be warranted under the terms of the Limited Warranty for a period not exceeding the remaining term of the original Limited Warranty or six (6) months, whichever is longer.
3. For any part or parts of this appliance, which in our judgment show evidence of defects, Blaze King reserves the option to repair or to replace the defective part(s) through an accredited distributor or agent, provided the defective part is returned to the distributor or agent, transportation prepaid, if requested.
4. If you discover a problem that you think may be covered by the Limited Warranty, you **MUST REPORT** it to your Blaze King dealer **WITHIN 30 DAYS** from the date the problem was first detected, giving them proof of purchase and the date of purchase. The dealer will investigate the problem and work with Blaze King to determine whether the problem:
  - a) Is covered by the Limited Warranty or
  - b) Can be fixed in your home or does the product need to be returned to Blaze King for repair.
5. If Blaze King determines that the appliance needs to be returned to Blaze King for repair, the customer has the responsibility and the expense of removing it from their home and shipping it to Blaze King. If the problem is covered by the Warranty, Blaze King will repair or replace the item at their discretion and the customer will be responsible for return shipping and re-installation in their home.
6. If the problem is not covered by the Limited Warranty, the customer will be responsible for all repair costs, as well as all storage, shipping and the cost of removing and re-installing the appliance.

If you are not satisfied with the service provided by the Blaze King dealer, write to Blaze King at the address listed on the last page of the Owner's Manual. Include a copy of the original purchase invoice and a description of the problem.

**Exclusions and Limitations:**

1. This Warranty does not cover tarnish, discoloration or wear on the plated surfaces. Painted finishes will change color after initial firing and will continue to change through the lifetime of the appliance. This is normal occurrence for all high temperature coatings.
2. This Warranty does not cover gasket material or firebrick.
3. Blaze King strongly recommends installation by a certified installer. Failure to comply may adversely affect coverage under the terms of this warranty. This Limited Warranty covers defects in materials and workmanship only if the product has been installed in accordance with local building and fire codes; in their absence refer to the owner's manual. If the product is damaged or broken as a result of any alteration, wilful abuse, mishandling, accident, neglect, or misuse of the product, the Limited Warranty does not apply.
4. The appliance must be operated and maintained at all times in accordance with the instructions in the Owner's Manual. If the unit shows signs of neglect or misuse, it is not covered under the terms of this Warranty policy. Performance problems due to operator error will not be covered by the Limited Warranty policy. Some minor expansion, contraction, or movement of certain parts and resulting noise, is normal and not a defect and, therefore, is not covered under this Limited Warranty.
5. Misuse includes over-firing. Over-firing can be identified later by warped plates and paint pigment being burnt off. Over-firing this appliance can cause serious damage and will nullify the Limited Warranty.
6. The Limited Warranty will cover glass thermal breakage only and will not cover misuse of the appliance glass, including but not limited to:
  - a) Glass that is struck, has surface contaminates or has had harsh or abrasive cleaners used on it.
  - b) If the door is slammed or is closed while wood in the firebox is protruding out the appliance opening thus striking the glass.
7. This warranty does not cover products made or provided by other manufacturers and used in conjunction with the operation of this appliance without prior authorization from Blaze King. The use of such products may nullify the Limited Warranty on this appliance. If unsure as to the extent of this Limited Warranty, contact your authorized Blaze King dealer before installation.
8. Blaze King will not be responsible for inadequate performance caused by environmental conditions.
9. The Limited Warranty does not cover installation and operational related problems such as use of downdrafts or spillage caused by environmental conditions. Environmental conditions include but are not limited to nearby trees, buildings, roof tops, wind, hills, mountains, inadequate venting or ventilation, excessive offsets, negative air pressures or other influences caused by mechanical systems such as furnaces, fans, clothes dryers etc.
10. The Limited Warranty does not cover damage caused by burning salt-saturated wood, corrosive driftwood, chemically treated wood or any fuel not recommended in the Owner's Manual (use cord wood only).
11. The Limited Warranty is void if:
  - a) The appliance has been operated in atmospheres contaminated by chlorine, fluorine or other damaging chemicals.
  - b) The appliance is subject to submersion in water or prolonged periods of dampness or condensation.
  - c) Any damage to the unit, combustion chamber or other components due to water, or weather damage which is the result of, but not limited to, improper chimney/venting installation.
  - d) Salt air in coastal areas or high humidity can be corrosive to the finish; these environmental conditions can cause rusting. Damage caused by salt air or high humidity is not covered by the Limited Warranty.
12. Exclusions to the Limited Warranty include: injury, loss of use, damage, failure to function due to accident, negligence, misuse, improper installation, alteration or adjustment of the manufacturer's settings of components, lack of proper and regular maintenance, alteration, or act of God.
13. The Limited Warranty does not cover damage caused to the appliance while in transit. If this occurs, do not operate the appliance and contact your courier and/or dealer.
14. The Limited Warranty does not extend to or include paint, door or glass gaskets or firebricks damage caused by normal wear and tear, such as paint discoloration or chipping, worn or torn gaskets, chipped or cracked firebrick, etc.
15. The Limited Warranty does not include damage to the unit caused by abuse, improper installation, or modification of the unit.
16. Damage to plated surfaces caused by fingerprints, scratches, melted items, or other external scores and residues left on the plated surfaces from the use of abrasive cleaners or polishes is not covered in this warranty.
17. Blaze King is free of liability for any damages caused by the appliance, as well as inconvenience expenses and materials. The Limited Warranty does not cover incidental or consequential damages.

18. The Limited Warranty does not cover any loss or damage incurred by the use or removal of any component or apparatus to or from the Blaze King appliance without the express written permission of Blaze King and bearing a Blaze King label of approval.
19. Any statement or representation of Blaze King Products and their performance contained in Blaze King advertising, packaging literature, or printed material is not part of the Limited Warranty.
20. The Limited Warranty is automatically voided if the appliance's serial number has been removed or altered in any way. If the appliance is used for commercial purposes, it is excluded from the Limited Warranty.
21. No dealer, distributor, or similar person has the authority to represent or warrant Blaze King Products beyond the terms contained within the Limited Warranty. Blaze King assumes no liability for such warranties or representations.
22. Blaze King will not cover the cost of the removal or re-installation of the appliance, hearth, facing, mantels, venting or other components.
23. Labor to replace or repair items under this Limited Warranty will be covered per our warranty service fee reimbursement and labor rates are set per component schedule. Labor rates vary from location to location and as such total labor costs may not be covered. Please consult with your dealer or service technician for any additional charges such as travel time or additional labor charges that may apply.
24. For parts of the Blaze King wood appliance or fireplace insert warranted beyond the first year, the five year limited warranty will have the same obligations as described in this document, provided, however that the purchaser shall pay the following percentage of the then current retail cost of the repair or the replacement, according to the year after purchase in the which the defect is brought to the attention of Blaze King.\*\*\* During the 2nd year----purchaser pays 20%. 3rd year ----purchaser pays 40%. 4th year -----purchaser pays 60%. 5th year---- purchaser pays 80%.
25. If a defect or problem is determined by Blaze King to be non warrantable, Blaze King is not liable for travel costs for service work. In the event of in-home repair work, the customer will pay any in-home travel fees or service charges required by the Authorized Dealer.
26. At no time will Blaze King be liable for any consequential damages which exceed the purchase price of the unit. Blaze King has no obligation to enhance or modify any appliance once manufactured (example: as a appliance model evolves, field modifications or upgrades will not be performed).
27. This Limited Warranty is applicable only to the original purchaser and it is nontransferable.
28. This warranty only covers Blaze King Products that are purchased through an authorized Blaze King dealer.
29. If for any reason any section of the Limited Warranty is declared invalid, the balance of the warranty remains in effect and all other clauses shall remain in effect.
30. The Limited Warranty is the only warranty supplied by Blaze King, the manufacturer of the appliance. All other warranties, whether express or implied, are hereby expressly disclaimed and the purchaser's recourse is expressly limited to the Limited Warranty.
31. Blaze King and its employees or representatives will not assume any liability for damages, either directly or indirectly, caused by improper usage, operation, installation, servicing or maintenance of this appliance.
32. Blaze King reserves the right to make changes without notice. Please complete and mail the warranty registration card and have the installer fill in the installation data sheet in the back of the manual for warranty and future reference.
33. Blaze King is responsible for stocking parts for a maximum of seven (7) years after discontinuing the manufacture or incorporation of the item into its products. An exception to this would be if an OEM supplier is not able to supply a part.
34. "Installation into unfinished or uninsulated basements often forces the user to operate the appliance continuously at peak output or over-fire in an effort to overcome heat loss. Blaze King does not recommend such installations. Doing so may adversely affect the appliance and therefore coverage under the terms of this limited warranty."



