

Blaze King

PRINCESS PE1006/PEJ1006

SOLID FUEL CATALYTIC STOVE



PE1006BK



PE1006LBK



PE1006UBK



This heater meets the 2015 U.S. Environmental Protection Agency's particulate emission limits for wood heaters sold after May 15, 2015.



Installer: Please complete the details on the back cover and leave this manual with the homeowner.
Homeowner: Please SAVE THESE INSTRUCTIONS for future reference.

The authority having jurisdiction (such a municipal building department, fire department, etc.) should be consulted before installation to determine the need to obtain a permit.

OPERATION & INSTALLATION MANUAL

Manufactured By

Valley Comfort Systems Inc., 1290 Commercial Way, Penticton, BC, V2A 3H5, Canada
Phone: 250-493-7444 w Fax: 250-493-5833 w www.blazeking.com w info@blazeking.com

Pour la version française de nos manuels S.V.P. vous référez à notre site web: www.blazeking.com

INTRODUCTION	4
SPECIFICATIONS	5
EMISSIONS	5
PRODUCT INFORMATION	6
<i>APPLIANCE DIMENSIONS—Princess Classic PE1006BK</i>	6
<i>APPLIANCE DIMENSIONS—Princess Parlor PE1006LBK</i>	7
<i>APPLIANCE DIMENSIONS—Princess Ultra PE1006UBK</i>	8
CERTIFICATION LABEL	9
SAFETY PRECAUTIONS	10
INSTALLATION INSTRUCTIONS	13
<i>PARTS INCLUDED WITH THE PRINCESS</i>	13
<i>OPTIONAL EQUIPMENT</i>	13
<i>FLOOR PROTECTION</i>	13
<i>MINIMUM CLEARANCES for PE1006 and PEJ1006</i>	14
<i>COMBUSTION AIR</i>	15
<i>DRAFTING PERFORMANCE</i>	15
<i>ROLE OF THE CHIMNEY</i>	15
<i>VENTING SYSTEMS</i>	16
<i>RECOMMENDED FLUE HEIGHTS</i>	19
<i>MOBILE HOME (AND RESIDENTIAL ALCOVE INSTALLATIONS)</i>	20
<i>OPTIONAL ACCESSORIES</i>	21
OPERATING INSTRUCTIONS	24
<i>INTRODUCTION</i>	24
<i>YOUR FIRST FIRE!</i>	24
<i>BYPASS</i>	24
<i>CATALYTIC THERMOMETER</i>	24
<i>THERMOSTAT</i>	25
<i>SELECTING WOOD</i>	25
<i>HOW TO USE MOISTURE METERS</i>	26
<i>EFFICIENCY</i>	26
<i>LIGHTING THE FIRE</i>	27
<i>RELOADING PROCEDURE (with the catalyst temperature in the ACTIVE ZONE)</i>	28
<i>RELOADING PROCEDURE (with the catalyst temperature still in the INACTIVE ZONE)</i>	28
<i>OPTIMAL THERMOSTAT SETTING</i>	28
<i>FAN OPERATION</i>	29
<i>ICE - FORMATION AND PREVENTION</i>	29
<i>WOOD BURNING IN THE SHOULDER SEASON</i>	29
CATALYST MONITORING	30
CATALYST MONITORING	30
<i>CATALYTIC COMBUSTOR, TESTING</i>	30
<i>CATALYTIC COMBUSTOR, CLEANING</i>	30
<i>CATALYTIC COMBUSTOR, TROUBLESHOOTING</i>	31
<i>CATALYTIC COMBUSTOR, REPLACEMENT</i>	33

MAINTENANCE	36
<i>RUN-AWAY OR CHIMNEY FIRE</i>	36
<i>CREOSOTE FORMATION AND REMOVAL</i>	36
<i>CHIMNEY MAINTENANCE</i>	36
<i>CHIMNEY MAINTENANCE</i>	37
<i>FIRE EXTINGUISHERS AND SMOKE DETECTORS</i>	37
<i>ASH REMOVAL</i>	37
<i>LOADING DOOR GASKET INSPECTION</i>	38
<i>LOADING DOOR GASKET REPLACEMENT</i>	38
<i>BYPASS DOOR GASKET INSPECTION</i>	38
<i>BYPASS DOOR GASKET REPLACEMENT</i>	39
<i>DOOR GLASS GASKET INSPECTION</i>	40
<i>DOOR GLASS GASKET REPLACEMENT</i>	40
<i>DOOR GLASS, CLEANING</i>	40
<i>LOADING DOOR TENSION ADJUSTMENT</i>	41
<i>OPTIONAL FAN ASSEMBLY</i>	42
<i>THERMOMETER</i>	42
<i>THERMOSTAT</i>	42
TROUBLESHOOTING	43
REPLACEMENT PARTS	46
WARRANTY	53
INSTALLER NOTES	60

⚠ WARNING

- **THIS APPLIANCE IS HOT WHEN OPERATED AND CAN CAUSE SEVERE BURNS IF CONTACTED.**
- **ANY CHANGES OR ALTERATIONS TO THIS APPLIANCE OR ITS CONTROLS CAN BE DANGEROUS AND IS PROHIBITED BY FEDERAL AND STATE LAWS.**
- Do not operate appliance before reading and understanding operating instructions. Failure to operate appliance according to operating instructions could cause fire or injury.
- Before installing this appliance, contact the local building or fire authority and follow their guidelines.
- This appliance must be installed by a qualified installer.
- Risk of burns. The appliance should be turned off and cooled before servicing.
- Do not operate without fully assembling all components.
- Do not let the appliance become hot enough for any part to glow red.
- Do not install damaged, incomplete or substitute components.
- Risk of cuts and abrasions. Wear protective gloves and safety glasses during installation. Sheet metal edges may be sharp.
- Children and adults should be alerted to the hazards of high surface temperature and should stay away to avoid burns or clothing ignition.
- Young children should be carefully supervised when they are in the same room as the appliance. Toddlers, young children and others may be susceptible to accidental contact burns. A physical barrier is recommended if there are at risk individuals in the house. To restrict access to an appliance or appliance, install an adjustable safety gate to keep toddlers, young children and other at risk individuals out of the room and away from hot surfaces.
- Clothing or other flammable material should not be placed on or near the appliance. Objects placed in front of the appliance must be kept a minimum of 48" away from the front face of the appliance.
- Due to high temperatures, the appliance should be located out of traffic and away from furniture and draperies.
- Ensure you have incorporated adequate safety measure to protect infants / toddlers from touching hot surfaces.
- Even after the appliance is out, all surfaces, including the glass and/or any attachment will remain hot for an extended period of time.
- Check with your local hearth specialty dealer for safety hearth guards to protect children from hot surfaces. These guards must be fastened to a wall and/or to the floor.
- Any safety guard removed for servicing must be replaced prior to operating the appliance.
- Under no circumstances should this appliance be modified.
- This appliance must not be connected to a chimney flue pipe servicing a separate solid fuel burning appliance.
- Do not operate the appliance with the glass door removed, cracked or broken. Replacement of the glass should be done by a licensed or qualified service person.
- Do not strike or slam shut the appliance glass door.
- Operate only with the doors tightly closed.
- Appliance will over-fire if door is not shut and latched.
- Only certified doors / optional fronts / and surrounds for inserts with the unit are to be installed on the appliance.
- Keep the packaging material out of reach of children and dispose of the material in a safe manner. As with all plastic bags, these are not toys and should be kept away from children and infants.
- If the appliance is not properly installed, a house fire may result. Do not expose the appliance to the elements (rain, etc.) and keep the appliance dry at all times.
- The chimney must be sound and free of cracks and obstructions. Clean your chimney regularly as required.
- Never use gasoline, gasoline-type lantern fuel, kerosene, charcoal lighter fluid, or similar liquids to start or 'freshen up' a fire in this heater. Keep all such liquids well away from the heater while it is in use.
- Your appliance requires periodic maintenance and cleaning. Failure to maintain your appliance may lead to smoke spillage in your home.
- Higher efficiencies and lower emissions will generally result when burning air dried seasoned woods, as compared to wet, green or freshly cut wood. Burning wet unseasoned wood can cause excessive creosote accumulation. When ignited it can cause a chimney fire that may result in a serious house fire.
- The appliance is designed to burn seasoned wood only. Do not burn treated wood, coal, charcoal, colored paper, cardboard, solvents or garbage.
- Burn wood directly on the firebricks. Do not use a grate or elevate the fire.
- Do not store wood within appliance installation clearances or within the space required for re-fueling and ash removal.
- Ashes must be disposed in a metal container with a tight lid and placed on a non-combustible surface well away from the home or structure until completely cool.

Model	PE/PEJ 1006 (catalytic)
Height Classic	29 1/8" (740 mm)
Height Parlor	33 5/8" (854 mm)
Height Ultra	35" (889 mm)
Width	27" (686 mm) (without removable bypass handle)
Depth	30 3/4" (781 mm) (without optional fan kit)
	31 5/8" (804 mm) (with optional fan kit)
Flue collar	6" I.D.
Recommended flue draft	.05" water column (on high burn)
Fire door opening	16 3/8" x 8 1/4" (416 mm x 210 mm)
Firebox depth	18" (458 mm) brick to brick, 20 1/2" (521 mm) brick to glass
Firebox width	21 1/8" (537 mm)
Firebox height	12 1/2" (318 mm)
Fire box capacity	2.85 cu. ft.
Recommended Fuel length	16" max. (407 mm)
Wood capacity (approximate):	White oak - 60 lbs. (27.21 kg)
	Fir - 40 lbs. (18.14 kg)
Construction	10 gauge & 1/4" firebox, brick lined. 16 gauge outer shields
Shipping Weight	355-400 lbs. (161-182 kg)
Chimney recommendation	15' from stove top to chimney cap.

This unit was tested and listed UL 1482 (9/88) and ULC-S627 by Intertek testing laboratories.

This manual describes the installation and operation of the Princess PEJ1006 catalytic equipped wood heater.

This heater is certified to comply with the 2015 U.S. Environmental Protection Agency's particulate emission limits for wood heaters sold after May 15, 2015.

Under specific test conditions this heater has been shown to deliver heat at rates ranging from 12000 to 35600 Btu/hr. This wood heater has a manufacturer-set minimum low burn rate that must not be altered. It is against federal regulations to alter this setting or otherwise operate this wood heater in a manner inconsistent with operating instructions in this manual.

This wood heater contains a catalytic combustor, which needs periodic inspection and replacement for proper operation. It is against federal regulations to operate this wood heater in a manner inconsistent with operating instructions in this manual, or if the catalytic element is deactivated or removed.

The combustor supplied with this heater is a Z4400G ceramic combustor. Consult the catalytic combustor warranty also supplied with this wood heater. Warranty claims should be addressed to:

in Canada	in USA
Blaze King Industries / Valley Comfort Systems Warranty Department, 1290 Commercial Way Penticton, BC Canada V2A 3H5, Ph: 250-493-7444	Blaze King Industries Warranty Department, 146A Street Walla, Walla, Washington 99362, Ph: 509-522-2730

APPLIANCE DIMENSIONS—Princess Classic PE1006BK

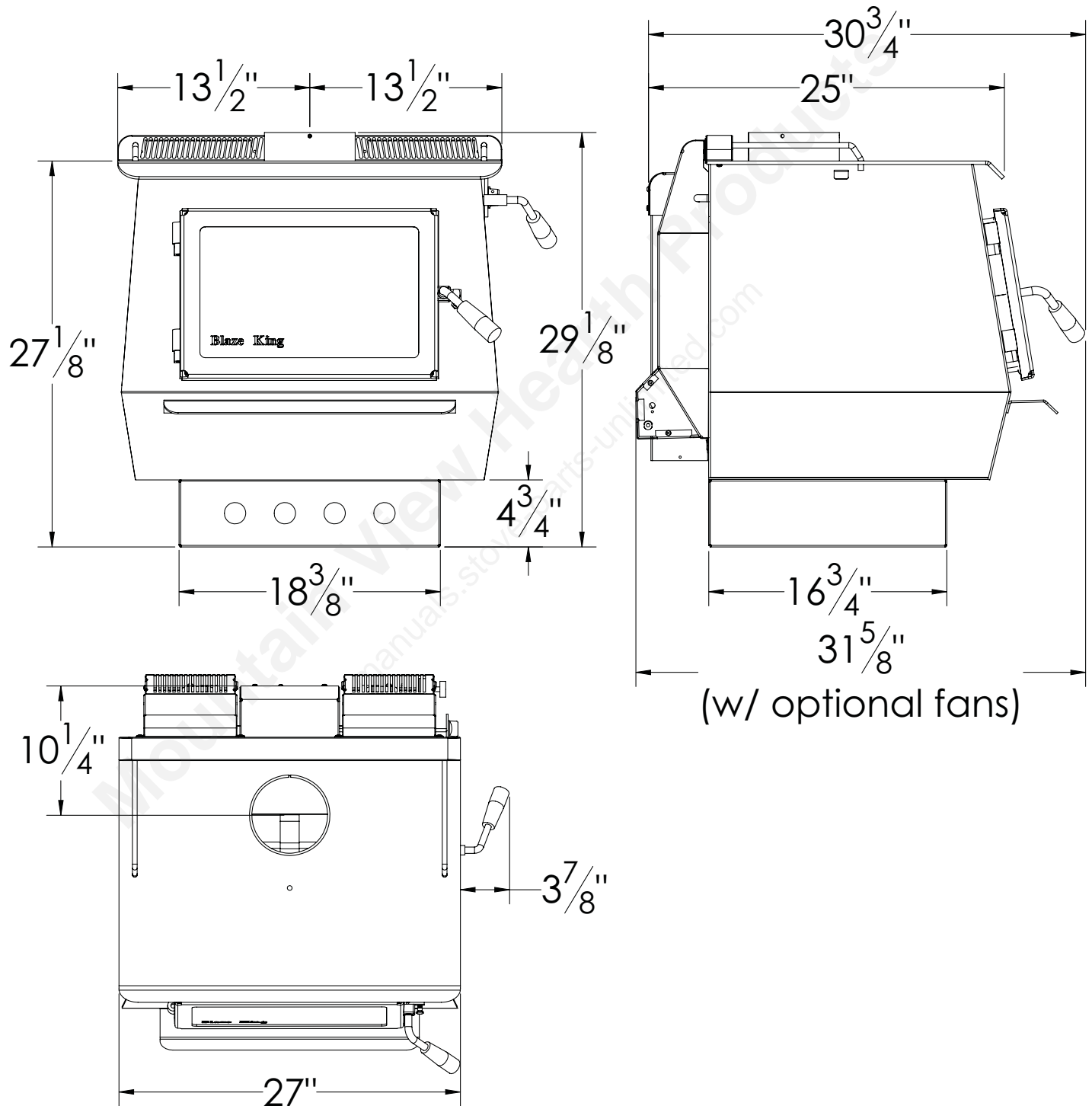

APPLIANCE DIMENSIONS—Princess Parlor PE1006LBK

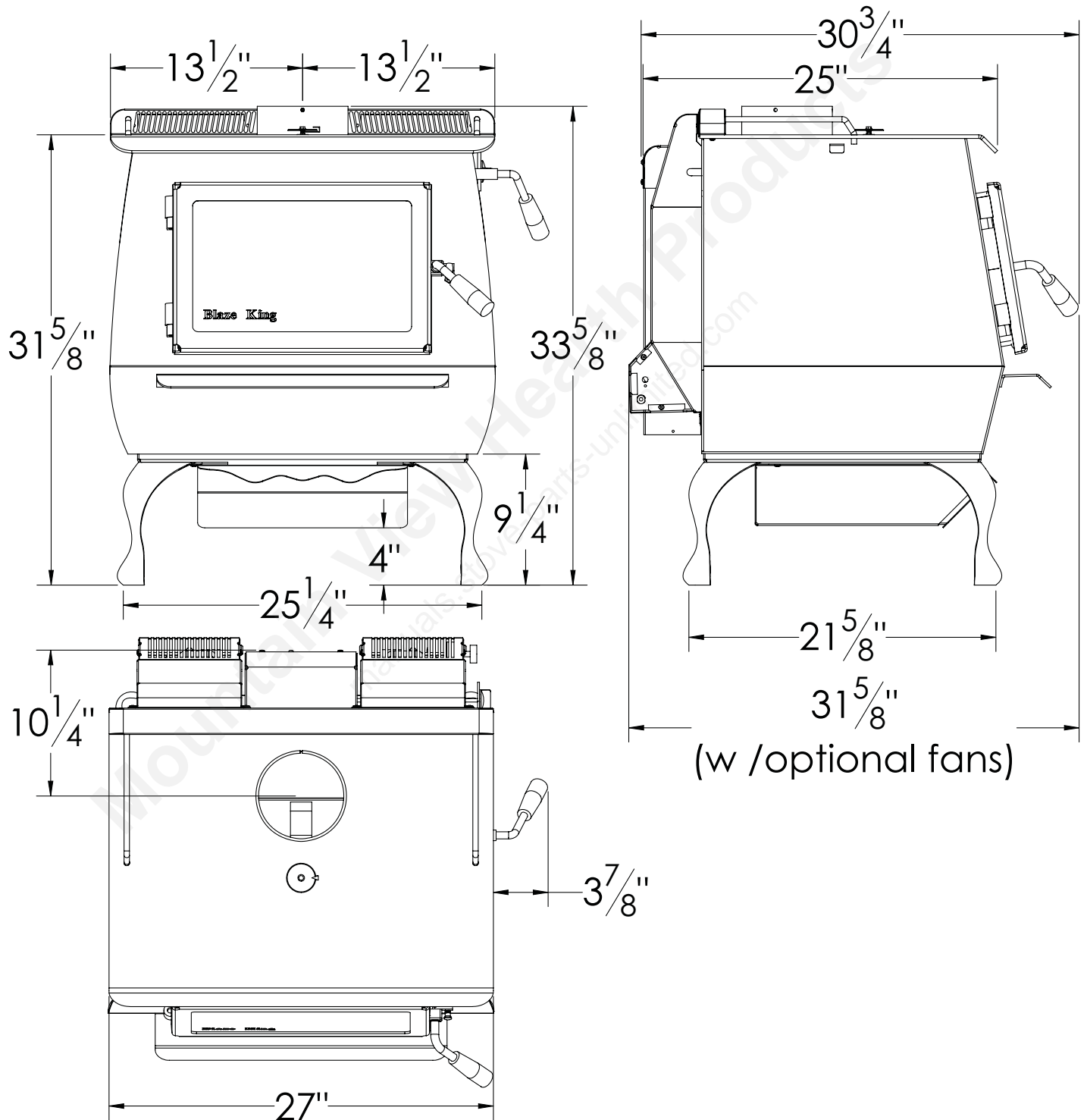

APPLIANCE DIMENSIONS—Princess Ultra PE1006UBK

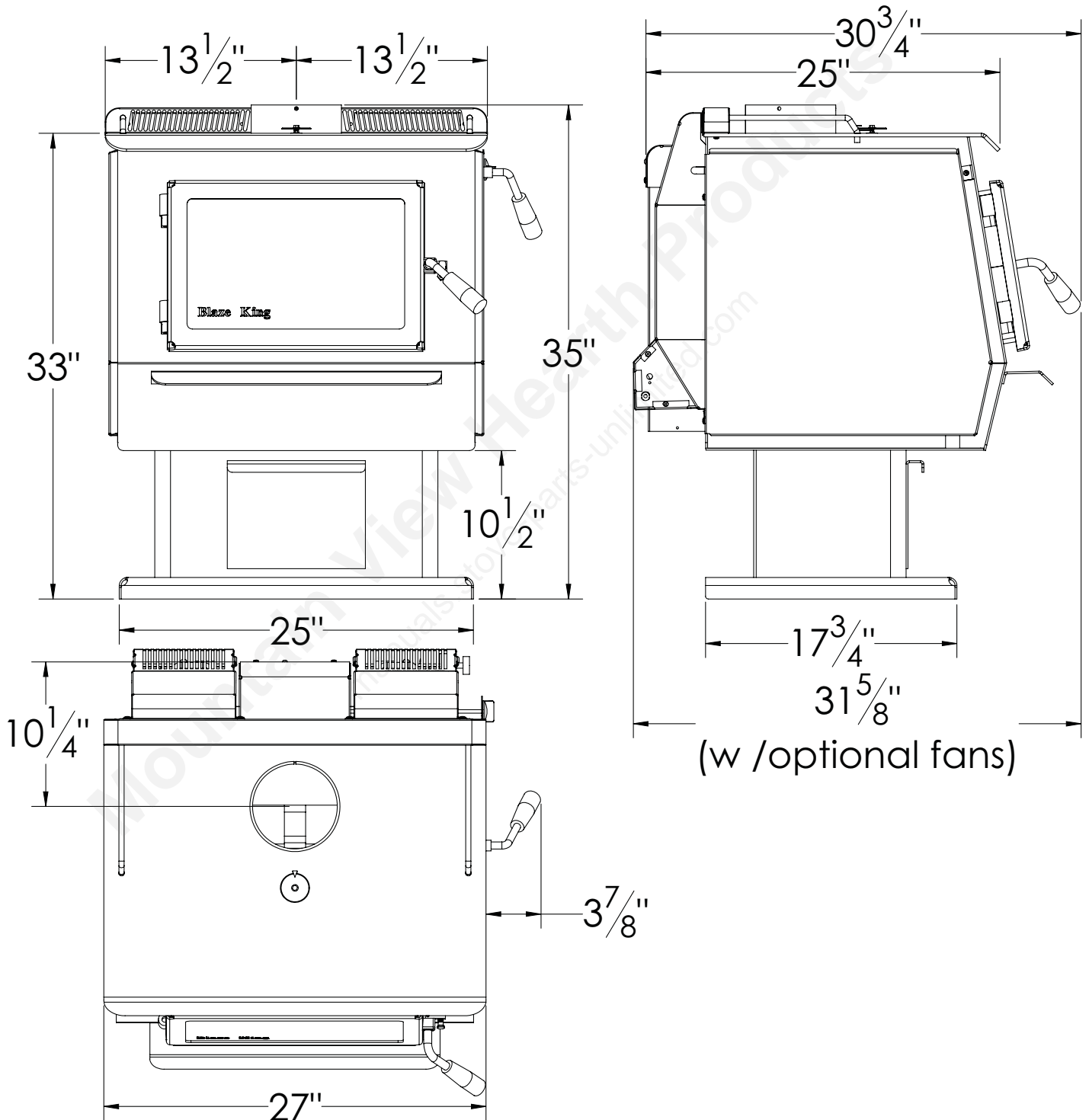



BLAZE KING CATALYST STOVE - PE(J)1006
POÈLE À BOIS CATALYTIQUE

W/N #16626

WH- P

LISTED ROOM HEATER, SOLID FUEL TYPE / APPAREIL APPROUVÉE DE TYPE CARBURANT
 SUITABLE FOR MOBILE-HOME INSTALLATION. CONCU POUR MAISONS MOBILES.
 Appareil approuvé de type carburant solide, aussi adapté pour installer une maison mobile.
 MODEL/MODELE: PE1006/PEJ1006 Tested to / Testé: UL 1482 (9/88) / CSA B366.2 ULC S627
 CERTIFIED IN BOTH UNITED STATES AND CANADA / CERTIFIÉ POUR LES ÉTATS-UNIS ET LE CANADA

PREVENT HOUSE FIRES- Install and use only in accordance with Blaze King's installation and operation instructions. Contact local building or fire officials about restrictions and installation inspection in your area. The flue size is 6".
CHIMNEYS: DO NOT CONNECT THIS UNIT TO A CHIMNEY FLUE SERVING ANOTHER APPLIANCE. Except for installation detailed below, use 6" listed factory built chimney suitable for use with solid fuels and conforming to, ULC629 in Canada or UL-103HT in the USA or a masonry residential type chimney.

Mobile Home, residential close clearance, and residential alcove installations require a 6" listed double wall close clearance chimney connector, with matching listed factory built chimney suitable for use with solid fuels and conforming to, ULC629 in Canada or UL-103HT in the USA. Mobile Home installations are only allowed with a roof exit. Do not install in a sleeping room. Alcove minimum width 47", maximum depth 48", minimum height 49" above stove top. Passing through a wall or ceiling requires special methods: see instructions and local building codes. Electrical rating: 115 VAC, 60 Hz, 0.58 Amps. Risk of electrical shock. Disconnect power before servicing unit. Do not route power cord in front of or beneath heater.

POUR PRÉVENIR UN INCENDIE Installer et employer seulement selon le manuel des directives d'installation de Blaze King. Contacter les fonctionnaires locaux de bâtiment ou de feu au sujet des restrictions et de l'inspection d'installation dans votre secteur.
 La taille de conduite de cheminée est 6".

CHEMINÉE: NE PAS CONNECTER CET APPAREIL A UN CONDUIT DE CHEMINÉE SERVANT UN AUTRE APPAREIL. Excepté pour les installation détaillée ci-dessous, employer avec une cheminée 6" approuvé pour l'utilisation avec les combustibles solides et conformément à ULC629 au Canada ou à UL-103HT aux Etats-Unis ou un type de cheminée résidentiel de maçonnerie.

Le dégagement étroit de maison mobile, et de les installations résidentielles de chambrette exigent des conduits de 6" à double paroi de cheminée approuvé au dégagement de fin de mur, avec une cheminée approuvée construite par une usine appropriée pour l'utilisation avec les combustibles solides et conformément à l' ULC629 au Canada ou l' UL-103HT AUX Etats-Unis. On permet seulement l'installation dans une maison mobile avec une sortie de toit. Ne pas installer dans une chambre à coucher. Largeur minimum de 47" de chambrette " profondeur maximum 48 " taille minimum 49 " au -dessus du poêle. Pour passer au travers d'un mur ou d'un plafond ceci exige des méthodes spéciales: voir les directives et les codes locaux de bâtiment. Estimation électrique: 115VAC, 60 hertz, 0.58 ampère, risque de choc électrique, débrancher l'alimentation électrique avant l'entretien de l'unité. Ne pas faire courir le cordon d'alimentation devant ou sous l'appareil.

MINIMUM CLEARANCES TO COMBUSTIBLES (See owners manual for complete description of all requirements)
 DÉGAGEMENTS MINIMUM AUX COMBUSTIBLES (voir les directives d'installation dans le manuel pour la description complète de toutes les conditions)

Residential Installations / Installations résidentielles	A	B	C	D	E	F
Roof exit, parallel and corner. Sortie de toit, parallèle et coin.	16" 407mm	9" 229mm	29.5" 750mm	19.25" 489mm	14" 356mm	28" 712mm
Roof exit, reduced side. Use side shields Sortie de toit, côté réduits. Utiliser des panneaux latéraux.	10" 254mm	9" 229mm	23.5" 597mm	19.25" 489mm		
Roof exit, reduced corner. Use side shields and either fan kit or rear shield Sortie de toit, coin réduits. Utiliser des panneaux latéraux et kit de ventilateur / panneaux arrière.					6" 153mm	20" 508mm
Roof exit, close clearance. Use side shields and either fan kit or rear shield. dégagement étroit, utiliser des panneaux latéraux, et kit de ventilateur / panneaux arrière.	10" 254mm	6" 153mm	23.5" 597mm	16.25" 413mm		
Wall exit, parallel and corner. Sortie, parallèle et coin.	16" 407mm	9" 229mm	29.5" 750mm	19.25" 489mm	14" 356mm	28" 712mm
Wall exit, reduced side. Use side shields Sortie de mur, côté réduit. Utiliser des panneaux latéraux.	10" 254mm	9" 229mm	23.5" 597mm	19.25" 489mm		
Wall exit, reduced corner. Use side shields and either fan kit or rear shield. Sortie de mur, coin réduit. Utiliser des panneaux latéraux/ kit de ventilateur / panneaux arrière.					7" 178mm	21" 535mm
Alcove roof exit. Use side shields and either fan kit or rear shield. Chambrette, sortie de toit. Utiliser des panneaux latéraux/et kit de ventilateur / panneaux arrière.	10" 254mm	6" 153mm	23.5" 597mm	16.25" 413mm		
Mobile Home Installations / Installations pour maison mobile						
Roof exit parallel and corner. Use side shields, either fan kit or rear shield and outside air kit La sortie du toit, parallèle et le coin utiliser les boucliers latéraux, ou kit de ventilateur ou un bouclier et un kit d'air extérieur.	10" 254mm	6" 153mm	23.5" 597mm	16.25" 413mm	6" 153mm	20" 508mm

* Check with local codes and pipe manufacturer for pipe clearances. In Canada, 18" clearances from single wall pipe is required.
 * Vérifier avec les codes locaux et manufacturiers des conduits pour les dégagements. Au Canada, dégagement de 18" pour le tuyaux à paroi simple est requis

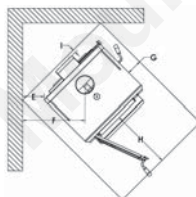

Floor protection may be any non-combustible material or Listed Floor Protector, and must extend at least 18" (458 mm) in Canada or 16" (407 mm) in U.S.A., in front of the loading door opening. In USA, minimum size is 33" x 42 3/8" (839 x 1077 mm). In Canada, minimum size is 43" x 52 3/8" (1093 x 1331 mm).

U.S. ENVIRONMENTAL PROTECTION AGENCY - 2015 Standard - certified to comply with 2015 particulate emission standards (EPA test methods 28 and 5G with an emission-rate of 2.42 g/hr). Not approved for sale after May 15, 2020. This wood heater needs periodic inspection and repair for proper operation. Consult the owner's manual for further information. It is against federal regulations to operate this wood heater in a manner inconsistent with operating instructions in the owner's manual, or if the catalytic element is deactivated or removed.

*ONLY OPERATE WITH DOORS CLOSED. Open door to feed fire ONLY. *DO NOT OBSTRUCT COMBUSTION AIR OPENINGS. Do not obstruct the space beneath the heater. For Use With Solid Wood Fuel Only - Do not burn other fuels, this may make the catalyst in the combustor inactive. The performance of the catalytic device or its durability has not been evaluated as part of the certification. Combustor part number: Z4400G. Provide adequate outside air for combustion. *Replace with only ceramic glass, 5 mm. thickness.

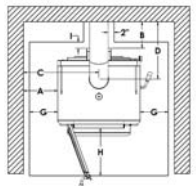

La protection de plancher peut être n'importe quel matériel non combustible ou Protecteur de plancher approuvé, et doit se prolonger au moins, 18" (458 mm) au Canada ou 16" (407 mm) aux Etats-Unis, devant l'ouverture de la porte de chargement. Aux Etats-Unis, la taille minimum est de 33" x 42 3/8" (839 x 1077 mm). Au Canada la taille minimum est 43" x 52 3/8" (1093 x 1331 mm).

AGENCE DE PROTECTION DE L'ENVIRONNEMENT U.S.- STANDARD 2015 - certifié conformément aux normes standard d'émissions de particules 2015 (Méthodes de test 28 et 5G EPA avec un taux d'émission de 2.42 g/lire). Non approuvé pour la vente après le 15 mai 2020. Cet appareil de chauffage au bois nécessite des inspections périodiques et des réparations pour un fonctionnement adéquat. Consulter le manuel du propriétaire pour plus d'informations. Il est contre les règlements fédéraux de faire fonctionner cet appareil de chauffage à l'encontre des instructions d'utilisation fournies dans le manuel du propriétaire, ou si l'élément catalytique est enlevé ou désactivé.

*Utiliser uniquement avec les portes fermées. Ouvrir la porte pour alimenter le feu SEULEMENT. *Ne pas obstruer l'ouverture d'air de combustion. Fournir de l'air extérieur adéquat pour la combustion. Ne pas obstruer l'espace sous le poêle. Utiliser uniquement avec des combustibles solides - Ne pas brûler aucune autres combustibles, ce qui peut rendre le catalyseur dans la chambre de combustion inactif. La performance du catalyseur ou sa longévité n'a pas été évaluée dans le cadre de la certification. Numéro de la pièce de combustion: Z4400G. *Employer seulement le verre en céramique si le remplacement est nécessaire, d'une épaisseur de 5mm.

MANUFACTURE DATE

G - 3" (77 mm) in U.S.A.
 8" (203 mm) in Cvanada
 H - 16" (406 mm) in U.S.A.
 18" (456 mm) in Canada

Fabriqué au

USA: Blaze King Industries
 146A Street
 Walla Walla, WA.
 99362
 CANADA: Valley Comfort Systems
 1290 Commercial Way
 Penticon, B.C.
 V2A 3H5

JAN FEB MAR APR MAY JUN
 JUL AUG SEP OCT NOV DEC
 2015 2016 2017 2018 2019 2020

#0217PE 06 15.indd

IF THIS BLAZE KING APPLIANCE IS NOT PROPERLY INSTALLED OR OPERATED, A HOUSE FIRE MAY RESULT. TO REDUCE THE RISK OF FIRE, FOLLOW THE INSTALLATION INSTRUCTIONS. CONTACT LOCAL BUILDING OR FIRE OFFICIALS ABOUT RESTRICTIONS AND INSTALLATION INSPECTION REQUIREMENTS IN YOUR AREA.

PLEASE READ THIS ENTIRE MANUAL BEFORE YOU INSTALL AND USE YOUR NEW APPLIANCE. FAILURE TO FOLLOW INSTRUCTIONS MAY RESULT IN PROPERTY DAMAGE, BODILY INJURY, OR EVEN DEATH.

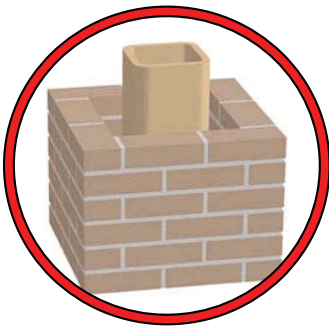

This appliance must be connected to a listed high temperature (**ULC629 IN CANADA OR UL-103HT IN THE USA**) residential type factory built solid fuel chimney or an approved masonry chimney with a flue liner.

Chimney and chimney connector must be in good condition and kept clean.
NEVER vent the stove to other rooms of the building. Must be vented to the outside **ONLY**.
NEVER use a chimney or chimney connector smaller than the stove exhaust, unless approved by your local inspector.
NEVER vent the stove into a "Class B" gas vent chimney.
DO NOT CONNECT IN CONJUNCTION WITH ANY AIR DISTRIBUTION DUCTWORK UNLESS SPECIFICALLY APPROVED FOR SUCH INSTALLATIONS.

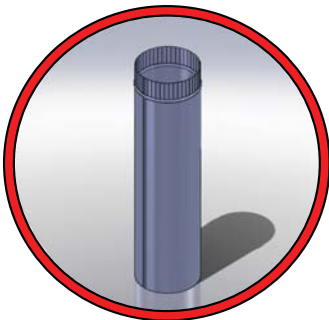

Inspect the chimney connector and chimney regularly during each burning season and clean when necessary.
DO NOT CONNECT THIS UNIT TO A CHIMNEY FLUE SERVING ANOTHER APPLIANCE.

NEVER intentionally start a chimney fire to clean the flue.



When installed in a mobile home, this appliance must be bolted to the floor and provided with outside air.

WARNING: DO NOT INSTALL IN A SLEEPING ROOM
CAUTION: THE STRUCTURAL INTEGRITY OF THE MOBILE HOME FLOOR, WALL, AND CEILING/ROOF MUST BE MAINTAINED.

Check with local building officials.



If the Optional Fan Kit is installed, connect this unit to a properly grounded, 110-volt electrical outlet. Do not route the power cord in front of or under the appliance.



Do not make any changes or modifications to an existing masonry fireplace or chimney to install this appliance. Do not make any changes to the appliance to increase combustion air.



Never try to repair or replace any part of this appliance unless instructions are given in this manual. All other work must be done by a trained technician.



Do not place clothing or other flammable items on or near this appliance.



Allow the appliance to cool down before carrying out any maintenance or cleaning.



DO NOT OVER FIRE THIS HEATER. Attempts to achieve heat output rates that exceed heater design specifications can result in permanent damage to the heater and to the catalytic combustor. Over firing the appliance may cause a house fire. Never burn the appliance so hot that the appliance or chimney connector begins to glow.



Maintain the door and glass seal and keep them in good condition. A leaking door seal will shorten burn times and may harm the combustor.



Do not use a grate or other device to elevate the fire off of the firebox floor. Burn the fire directly on the bricks.



Avoid placing wood against the glass when loading. Do not slam the door or strike the glass.

Do not throw this manual away. This manual has important operating and maintenance instructions that you will need at a later time. Always follow the instructions in this manual.



Ashes should be placed in a steel container with a tightly fitting lid and moved outdoors immediately. If the ashes are disposed of by burial in soil or otherwise locally dispersed, they should be retained in the closed container until all cinders have thoroughly cooled. Other waste shall not be placed in this container.



It is required in some jurisdictions to install smoke and carbon monoxide detectors where heaters are installed. Install at least one smoke detector on each floor of your home to ensure your safety. It should be located away from the wood appliance and close to the sleeping areas. Locating a smoke detector too close to a wood appliance can cause the smoke detector alarm to sound if a puff of smoke is emitted while the wood appliance door is open during reloading. Follow the smoke detector manufacturers placement, installation, and maintenance instructions.

This appliance is designed and approved for burning cord wood only. DO NOT burn trash, garbage; artificial or paper logs; gift wrappings; coal; lighter fluids; chemical cleaners; chemical starters; treated or painted wood; salt water driftwood or foil-backed paper such as gum wrappers or cigarette packages; lawn clippings or yard waste; materials containing rubber (including tires), plastic, asbestos; waste petroleum products, paints or paint thinners, or asphalt products; construction or demolition debris; railroad ties or pressure-treated wood; manure or animal remains; unseasoned wood or paper products, cardboard, plywood, or particleboard. The prohibition against burning these materials does not prohibit the use of fire starters made from paper, cardboard, saw dust, wax and similar substances for the purpose of starting a fire in an affected wood heater. Burning these materials may result in the release of toxic fumes or render the heater ineffective and cause smoke. Burn natural wood only. It will void all warranties and safety listings and may damage the combustor.



Never burn the appliance with the loading door open. Leaving the door cracked open may damage the combustor.



Never block free airflow through vents on this appliance.



Do not use chemicals or fluids to start the fire. Never use gasoline, gasoline-type lantern fuel, kerosene, charcoal lighter fluid, or similar liquids to start or 'freshen up' a fire in this heater. Keep all such liquids well away from the heater while it is in use. Some fuels could generate carbon monoxide and are very dangerous.

**HOT WHILE IN OPERATION.
KEEP CHILDREN,
CLOTHING AND FURNITURE
AWAY.
CONTACT MAY CAUSE SKIN
BURNS.**

Do not touch the appliance when it is hot and educate all children of the danger of a high temperature appliance. Young children should be supervised when they are in the same room as the appliance.



Keep furniture, curtains, wood, paper and other combustibles a minimum of 48in (1219mm) away from the front of the appliance. ALSO, DO NOT STORE COMBUSTIBLES UNDER THE APPLIANCE (WOOD, PAPER etc.).

This appliance must be properly installed to prevent the possibility of a house fire. The instructions must be strictly adhered to. Do not use makeshift methods or compromise in the installation.

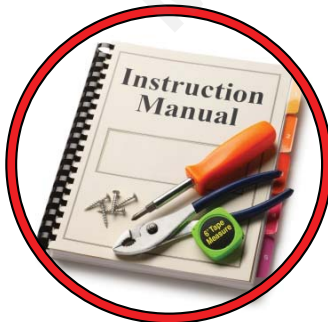

Contact local building officials to obtain a permit and information on any installation restriction or inspection requirements in your area. Notify your insurance company as well.

⚠ WARNING

- BEFORE INSTALLING THIS APPLIANCE, CONTACT THE LOCAL BUILDING OR FIRE OR OTHER AUTHORITY HAVING JURISDICTION AND FOLLOW THEIR GUIDELINES.
- THIS APPLIANCE MUST BE INSTALLED BY A QUALIFIED INSTALLER. FOLLOW THE INSTALLATION DIRECTIONS. DO NOT OPERATE WITHOUT FULLY ASSEMBLING ALL COMPONENTS.
- IF THIS APPLIANCE IS NOT PROPERLY INSTALLED, A HOUSE FIRE MAY RESULT.
- THIS APPLIANCE IS HOT WHEN OPERATED AND CAN CAUSE SEVERE BURNS IF CONTACTED. CHILDREN AND PETS MUST BE KEPT FROM TOUCHING THE APPLIANCE WHEN IT IS HOT.
- COMBUSTIBLE MATERIAL SUCH AS FIRE WOOD, WET CLOTHING, ETC. PLACED TOO CLOSE CAN CATCH FIRE. OBJECTS PLACED IN FRONT OF THE APPLIANCE MUST BE KEPT A MINIMUM OF 48”(1219 MM) FROM THE FRONT OF THE APPLIANCE.

Blaze King grants no warranty, implied or stated, for the installation or maintenance of the appliance and assumes no responsibility of any consequential damage(s).

**PARTS INCLUDED WITH THE PRINCESS**

- | | |
|----|--|
| 1. | Poker |
| 2. | Manual kit (w/ warranty cards, thermometer, fire starter, bypass handle) |

OPTIONAL EQUIPMENT

- | | | | |
|----|--|----|------------------------------------|
| 1. | Fan kit (Z1714) | 2. | Convection deck (Z1744) |
| 3. | Rear shield (Z4015) | 4. | Ash drawer (Z1710 on parlor model) |
| 5. | Side Shields (ZSSP1006) (Classic / Parlor) | 6. | Fresh air kit (Z1726B) |

FLOOR PROTECTION

If the stove sits on a combustible floor, a non-combustible shield must be used underneath the stove and extending 16” out from the front and 8” on either side of the fuel-loading door in the USA. In Canada a non-combustible shield must be used underneath the stove and extending 8” on either side and rear and 18” out in front of the loading door.

A non-combustible shield is also required underneath the chimney connector and extending at least 2” (50.8mm) on either side of the chimney connector.

See the next page for minimum sizes depending on model. This floor protection is required to prevent sparks from falling onto the combustible floor. See CSA B365-M87). **This product does not require thermal hearth pad protection.**

MINIMUM CLEARANCES for PE1006 and PEJ1006

Residential Installations	A	B	C	D	E	F	J
Roof exit, parallel and corner. No fan kit required.	16" 407 mm	9" 230 mm	29.5" 750 mm	19.25"* 489 mm	14" 360 mm	28"* 712 mm	49" 1245 mm
Roof exit, reduced side. Use side shields.	10" 254 mm	9" 230 mm	23.5" 597 mm	19.25"* 489 mm			49" 1245 mm
Roof exit, reduced corner. Use side shields and either fan kit or rear shield.					6" 153 mm	20"* 508 mm	49" 1245 mm
Roof exit, close clearance. Use side shields, and either fan kit or rear shield.	10" 254 mm	6" 153 mm	23.5" 597 mm	16.25"* 413 mm			49" 1245 mm
Wall exit, parallel and corner. No fan kit required.	16" 407 mm	9" 230 mm	29.5" 750 mm	19.25"* 489 mm	14" 360 mm	28"* 712 mm	49"* 1245 mm
Wall exit, reduced side. Use side shields.	10" 254 mm	9" 230 mm	23.5" 597 mm	19.25"* 489 mm			49"* 1245 mm
Wall exit, reduced corner. Use side shields and either fan kit or rear shield.					7" 180 mm	21"* 535 mm	49"* 1245 mm
Alcove, roof exit. Use side shields, and either fan kit or rear shield.	10" 254 mm	6" 153 mm	23.5" 597 mm	16.25"* 413 mm			49" 1245 mm
Mobile Home Installation							
Roof exit, parallel and corner. Use side shields, either fan kit or rear shield and outside air kit.	10" 254 mm	6" 153 mm	23.5" 597 mm	16.25"* 413 mm	6" 153 mm	20"* 508 mm	49" 1245 mm

* Check with local codes and pipe manufacturer for pipe clearances. In Canada, 18" clearances from single wall pipe is required.

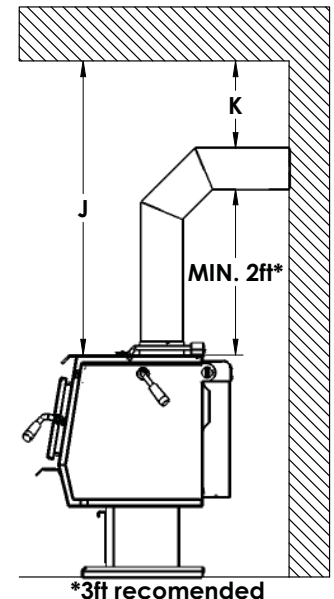
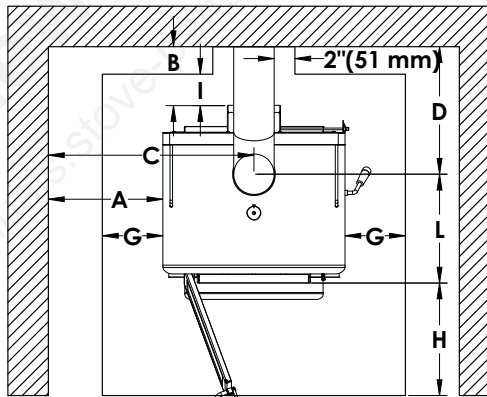
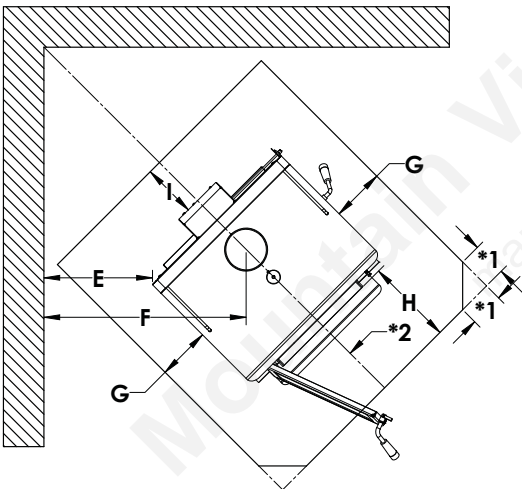

PE *1 = 5⁵/₈" in Canada and 2¹/₈" in USA

KE *1 = 6⁷/₈" in Canada and 2¹/₈" in USA

PE *2 = 73¹/₂" in Canada and 71¹/₂" in USA

KE *2 = 76⁵/₈" in Canada and 74⁵/₈" in USA

G = 3" (76mm) in USA
8" (203mm) in Canada

H = 16" (406mm) in USA
18" (456mm) in Canada

I = 0" (0mm) in USA
8" (203mm) in Canada

K = 18" (456mm) for single wall pipe in Canada

Ember protection shield (not required to have an insulation value)
is to be listed under UL 1618-2009 (type 1) and must have a minimum size of:

In USA: 33" x 42 3/8" (839 x 1077 mm)

In Canada: 43" x 52 3/8" (1093 x 1331 mm)

Min. Alcove minimum width 47", maximum depth 48", minimum height above stove top 49"

This stove must be installed in compliance with all local codes and regulations.

COMBUSTION AIR

Ensure adequate combustion air allowing for all other exhausting type appliances in the dwelling (range hoods, dryers, etc.). In air tight homes and modern constructions, careful considerations must be taken into account when using a wood burning appliance. Heat recovery ventilators (HRV) systems along with constant running pan motors in air handlers must be taken into account when balancing the system. Failure to do so may result in air starvation, smoke spillage and carbon monoxide threats. Consult a HVAC specialist for proper installation. Ensure adequate combustion air allowing for all other exhausting type appliances in the dwelling (range hoods, dryers, etc.). In airtight houses it is recommended to install a fresh air inlet into the room where the appliance is located, to prevent air starvation.

DRAFTING PERFORMANCE

Draft is the force which moves air into the appliance up through the chimney. The amount of draft created by your chimney depends upon length, offsets, insulating properties, obstructions (such as architectural design, trees), local geography and other factors.

External forces, such as outdoor temperature, wind, barometric pressure, topography, or factors inside the home (negative pressure from exhaust fans, chimneys, air infiltration, etc) may adversely affect draft.

Too much draft may cause excessive temperatures in the appliance and may damage the heater. An uncontrollable burn or excessive temperature indicates excessive draft.

Inadequate draft may cause back puffing (spillage) into the room and plugging of the chimney, chimney cap or spark arrestor screen. Inadequate draft may cause smoke to leak into the room through appliance or chimney connector joints. Poor draft can also lead to poor heat production and the inability for the combustor to remain active in lower burn rate settings.

High efficiency appliances, such as your Blaze King stove, may require some fine tuning of your chimney system in order to maximize performance.

Blaze King cannot be responsible for external forces leading to less than optimal performance.

ROLE OF THE CHIMNEY

Without a proper installed chimney, this appliance will not burn correctly.

The role of the chimney is to pull the proper amount of air into the firebox for the purpose of complete combustion. Incomplete combustion will lead to more smoke and pollution of the outside air. A proper operating chimney will allow the user to enjoy peak performance at all burn operating levels from low to high. Blaze King therefore recommends vertical installations with a minimum length of 15' from stove top to chimney cap. In all freestanding stove installations, use double wall stove pipe from the stove top to the ceiling support box. The use of double wall stove pipe does allow for reduced clearances, however most importantly, it helps to keep the chimney warm and improve draft.

For wall exits, the same suggestion applies. With the addition of the recommendation to use two 45 degree elbows rather than a single 90 degree elbow. The use of two 45 degree elbows will allow for both a smoother transition to the exterior chimney and will also shorten the horizontal run to the outside chimney. A minimum 36" rise is recommended prior to any elbows being used. When possible, outside chimney systems should be isolated from direct exposure to winter weather by building a chase around the chimney, observing all clearances as specified by the venting manufacturer. Doing so will help to keep the chimney warmer and improve draft.

VENTING SYSTEMS

The venting system consists of a chimney connector and a chimney. These get extremely hot during use. Temperatures inside the chimney may exceed 2000 degrees in the event of a creosote fire. To protect against the possibility of a house fire, the chimney connector and chimney must be properly installed and maintained. A listed thimble must be used when a connection is made through a combustible wall to a chimney. A chimney support package must be used when a connection is made through the ceiling to a listed prefabricated chimney. These accessories are absolutely necessary to provide safe clearances to combustible wall and ceiling material.

This stove may be connected to a lined masonry chimney or a listed factory built chimney suitable for use with solid fuels and conforming to, ULC629 in Canada or UL-103HT in the USA. Do not connect it to a chimney serving another appliance. To do so will affect the safe operation of both appliances, and will void the stove warranty. You must comply with the local authority having jurisdiction and/or in Canada, CSA installation standard B365-M87.

The chimney connector must be 6" diameter, 24 MSG Black/Blue steel. Do not use aluminum or galvanized steel. They cannot properly withstand the extreme temperatures of a wood fire. The chimney connector between the stove and the chimney should be as short and direct as possible.

The chimney connector must be attached to either an approved masonry chimney or one of the listed factory built chimneys suitable for use with solid wood fuel. All joints must be tight and fastened with sheet metal screws.

⚠ WARNING

THE CHIMNEY CONNECTOR IS TO BE USED ONLY WITHIN THE ROOM, BETWEEN THE STOVE AND CEILING / WALL. NEVER USE A CHIMNEY CONNECTOR TO PASS THROUGH AN ATTIC OR ROOF SPACE, CLOSET OR SIMILAR CONCEALED SPACE, OR A FLOOR, OR CEILING. AN EFFECTIVE VAPOR BARRIER MUST BE MAINTAINED AT THE LOCATION WHERE THE CHIMNEY OR COMPONENT PENETRATES TO THE EXTERIOR OF THE STRUCTURE. ALWAYS MAINTAIN THE MINIMUM CLEARANCES TO COMBUSTIBLES AS REQUIRED BY THE APPLICABLE BUILDING CODES.

CONNECTION TO A METAL PREFABRICATED CHIMNEY

When a metal prefabricated chimney is used, the manufacturer’s installation instructions must be followed precisely. You must also purchase (from the same manufacturer) and install the ceiling support package or wall pass through and “T” section package, fire stops (when needed), insulation shield, roof flashing, chimney cap, etc. Maintain the proper clearance to the structure as recommended by the manufacturer. This clearance is usually a minimum of 2 inches, although it may vary by manufacturer or for certain components.

There are basically two methods of metal chimney installation. One method is to install the chimney inside the residence through the ceiling(s) and the roof. The other method is to install an exterior chimney that runs up the outside of the residence (**not recommended**). If it is necessary to run the chimney outside, build an outside chase around the chimney.

The chimney must be the required height above the roof or other obstruction for safety and for proper draft operation. The requirement is that the chimney must be at least 3 feet higher than the highest point where it passes through the roof and at least 2 feet higher than the highest part of the roof or structure that is within 10 feet of the chimney, measured horizontally (**Fig. 1**). The height requirement is necessary in the interest of safety and does not necessarily assure proper flue draft. Use a minimum total system height of 15 feet, measured from the stove flue collar to the top of the chimney, not including the chimney cap.

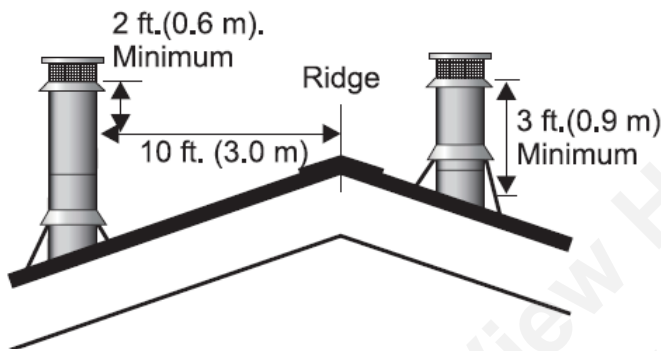

Use a minimum total system height of 15 feet, measured from the stove flue collar to the top of the chimney, not including the chimney cap.

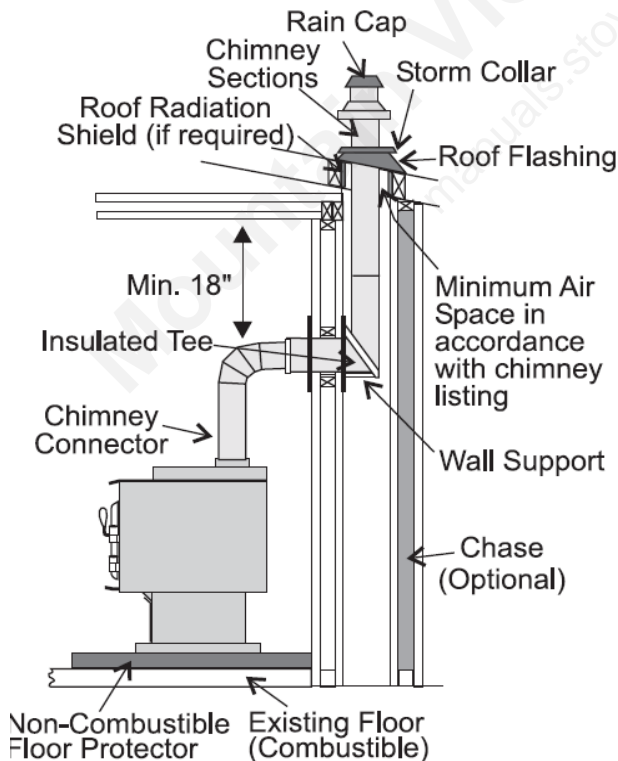

Horizontal Installation

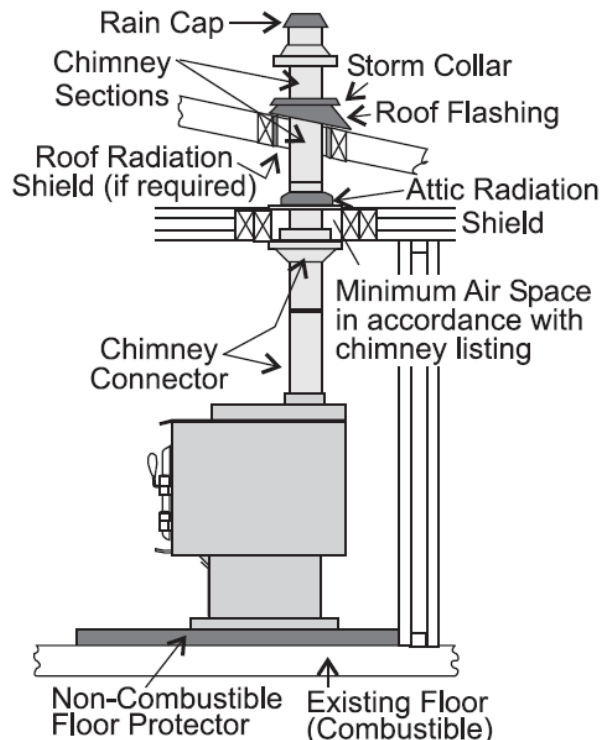

Standard Ceiling Installation

CONNECTION TO A MASONRY CHIMNEY

Masonry chimney***

Ensure that a masonry chimney meets the minimum standards (NFPA) by having it inspected by a professional. Make sure there are no cracks, loose mortar or other signs of deterioration and blockage. Have the chimney cleaned before the stove is installed and operated. When connecting the stove through a combustible wall to a masonry chimney, special methods are needed.

In Canada, the wall cut away is to provide 18" clearance for the connector. The resulting space must remain empty. A flush mounted sheet metal cover may be used on one side only. If covers are to be used on both sides, each cover must be mounted on noncombustible spacers at least 1" clear of the wall.

*****Blaze King recommends the use of a Stainless steel liner, preferably insulated, inside a masonry chimney. This to maintain proper draft and overall better operation of the unit.**

Your local dealer or local jurisdiction can provide details of approved methods of passing a chimney connector through a combustible wall in your area. In USA, the National Fire Protection Association has minimum standards to comply with. In Canada, this type of installation must conform to CAN/CSA-B365, Installation Code for Solid Fuel Burning Appliances and Equipment.

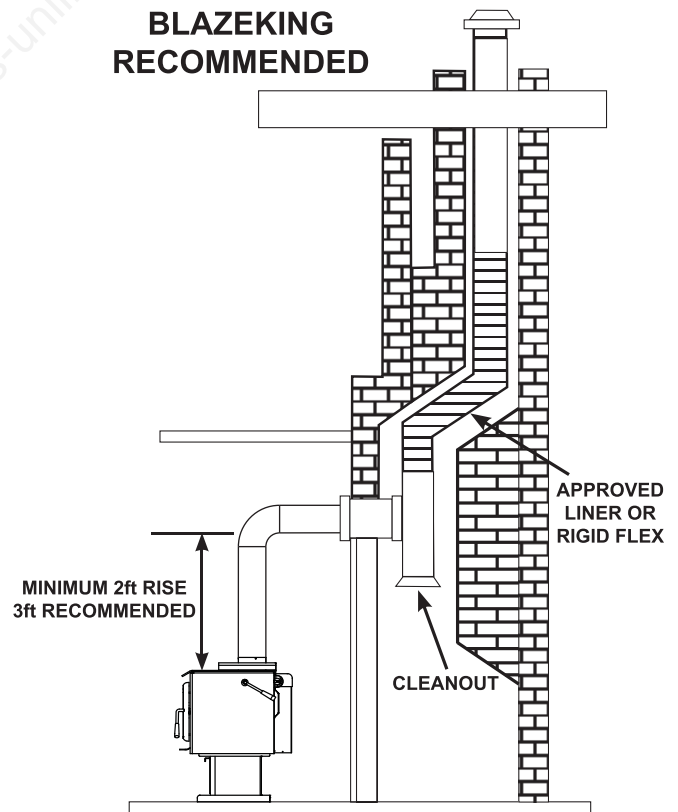
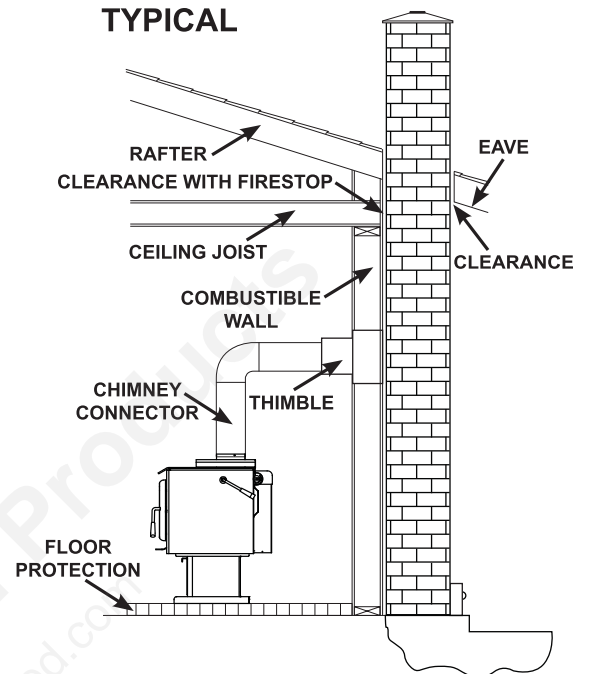

RECOMMENDED FLUE HEIGHTS

1. At sea level the minimum height is a 15 ft (4.6 m) straight run.
2. Add the following vertical height to the flue to compensate for:
 - 45° elbow = 1.0 ft (.30 m)
 - 90° elbow = 2.0 ft (.61 m)
 - "T" section = 3.0 ft (.91 m)
3. Each foot of horizontal run = 2 ft (.61 m) of vertical rise.

Example: One 90° elbow = 2ft (.61 m)
 2ft Horizontal run = 4ft (1.2 m)
 One base "T" = 3ft (.91 m)
 Total height addition = 9ft (2.7 m) at sea level

MINIMUM RECOMMENDED FLUE HEIGHT				
ELEVATION ABOVE SEA LEVEL	NUMBER OF ELBOWS			
	0	2 X 15°	2 X 30°	2 X 45°
0 - 1000 ft 0 - 305 m	15 4.6 m	16 4.9 m	18 5.5 m	19 5.8 m
1000 - 2000 ft 305 - 610 m	15.5 4.7 m	16.5 5.0 m	18.5 5.6 m	19.5 5.9 m
2000 - 3000 ft 610 - 914 m	16 4.9 m	17 5.2 m	19 5.8 m	20 6.1 m
3000 - 4000 ft 914 - 1219 m	16.5 5.0 m	17.5 5.3 m	19.5 5.9 m	20.5 6.2 m
4000 - 5000 ft 1219 - 1524 m	17 5.2 m	18 5.5 m	20 6.1 m	21 6.4 m
5000 - 6000 ft 1524 - 1829 m	17.5 5.3 m	18.5 5.6 m	20.5 6.2 m	21.5 6.6 m
6000-7000 ft 1829 - 2134 m	18 5.5 m	19 5.8 m	21 6.4 m	22 6.7 m
7000 - 8000 ft 2134 - 2438 m	18.5 5.6 m	19.5 5.9 m	21.5 6.6 m	22.5 6.9 m
NOTE: No more than one offset (two elbows allowed). Two 45° elbows equal one 90° elbow				

Please note: These are only guidelines. Please refer to the section in the manual pertaining to draft. Every installation is unique and can be influenced by topographical and geographical phenomena.

The use of a manometer and an understanding of pressure planes and the stack effect are imperative in planning and executing a successful installation.

MOBILE HOME (AND RESIDENTIAL ALCOVE INSTALLATIONS)

Requires side shields and outside air kit, and either rear shield OR fan kit. (See next page for kits and part numbers). The outside air kit is easiest to mount before the stove is installed. See instructions packed with each kit. **NOTE: UNDER NO CIRCUMSTANCES SHOULD THE FRESH AIR TUBE EVER BE INSTALLED HIGHER THAN THE BOTTOM OF THE APPLIANCE FIREBOX FLOOR**

When a metal prefabricated chimney is used, the manufacturer's installation instructions must be followed precisely. You must also purchase (from the same manufacturer) and install the ceiling support package, fire stops (when needed), insulation shield, roof flashing, chimney cap, etc. Maintain the proper clearance to the structure as recommended by the manufacturer.

Chimney connector must be double wall close clearance type with either ULC629 or ULCS610 designation. Single wall pipe is not allowed in Mobile Homes or in Alcove Installations. Insulated chimney components must be a listed factory built chimney suitable for use with solid fuels and conforming to, ULC629 in Canada or UL-103HT in the USA. For Mobile home, the chimney needs to be removable to allow for transportation of the mobile home.

⚠ WARNING

DO NOT INSTALL IN SLEEPING ROOM. THE STRUCTURAL INTEGRITY OF THE MOBILE HOME FLOOR, WALL AND CEILING / ROOF MUST BE MAINTAINED.

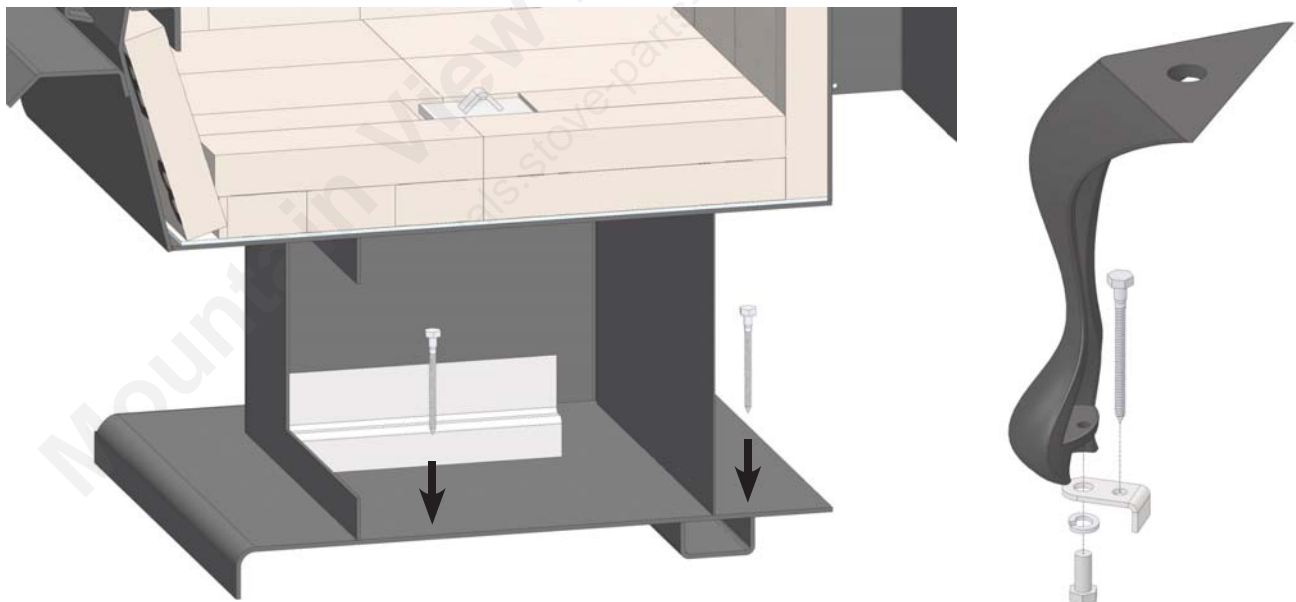

In mobile home installations, the stove must be securely fastened to the floor using the tie-downs provided in the Outside Air kit. (For the pedestal model, remove the ash drawer to access the screw down holes. For the Leg model, use the Leg Anchor Kit (P/N ZR8039) to secure stove to floor.) ALSO, a #8 ground wire must be attached to the stove and an appropriate ground.

OPTIONAL ACCESSORIES

MOBILE HOMES — Requires **SIDE SHIELDS (SS.PE1006)** and **OUTSIDE AIR KIT (Z1726B)**, and either **FAN KIT (Z1714)** or **REAR SHIELD (Z4015)**.

RESIDENTIAL ALCOVES — Requires **SIDE SHIELDS (SS.PE1006)**, and either **FAN KIT (Z1714)** or **REAR SHIELD (Z4015)**

SIDE SHIELDS (SS.PE1006)

Side shields are required for:

MOBILE HOMES and RESIDENTIAL ALCOVES

REAR SHIELD KIT (Z4015)

EITHER this rear shield or fan kit (Z1714) is REQUIRED FOR:
MOBILE HOMES and RESIDENTIAL ALCOVES

FAN KIT (Z1714)

EITHER this fan kit or rear shield (Z4015) is REQUIRED FOR:
MOBILE HOMES and RESIDENTIAL ALCOVES

NOTE: Fan Kit should be installed before the stove is placed into position

ELECTRICAL CONNECTION:

Your Blaze King fan kit is equipped with a three-prong (grounded) plug to decrease shock hazard. THIS PLUG SHOULD BE INSERTED DIRECTLY INTO A PROPERLY-GROUNDED, THREE-HOLE RECEPTACLE. DO NOT CUT OR REMOVE THE GROUNDING PRONG FROM THIS PLUG. Do not route the power cord in front or under the stove.

OUTSIDE AIR KIT (Z1726B)

REQUIRED FOR:

MOBILE HOMES

The outside air inlet hose is a flexible tube to bring outside air for combustion into the stove from outside the residence, through the wall or up through the floor. The flexible tube will allow some adjustment over or around floor joists or plumbing. DO NOT CHANGE THE STRUCTURAL INTEGRITY OF THE FLOOR. This air hose must be kept open at all times to provide outside air for combustion.

LEG KIT (Z1713BK) PARLOR MODELS ONLY

TOOLS NEEDED FOR INSTALLATION: 3/4" wrench or socket wrench

INSTALLATION

1. Lean stove backwards to gain access to stove bottom. **NOTE: Use extreme caution when leaning the stove over to avoid injury or damage to the flooring or appliance.**
2. Remove four 1/2" bolts from bottom pan of appliance. (see Fig. 1)
3. Position each leg accordingly and fasten to stove using the removed 1/2" bolts, as well as the supplied washer and lock washer. (see Fig. 2)
4. Lift stove back to its upright position.
5. Adjust carriage bolts in order to level stove.

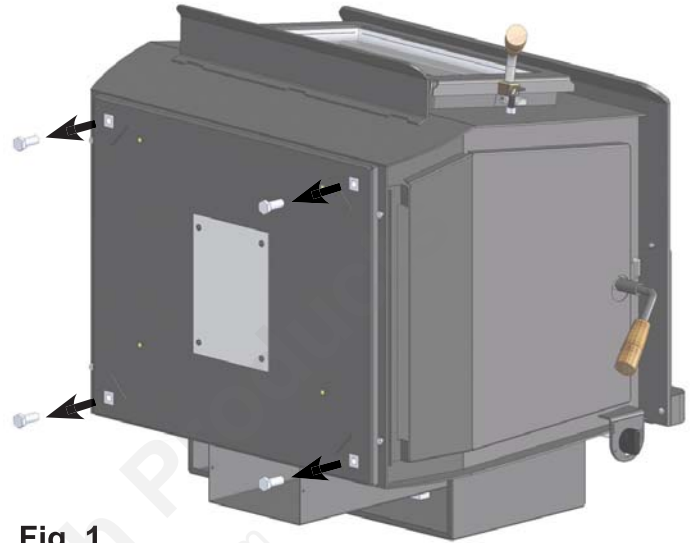
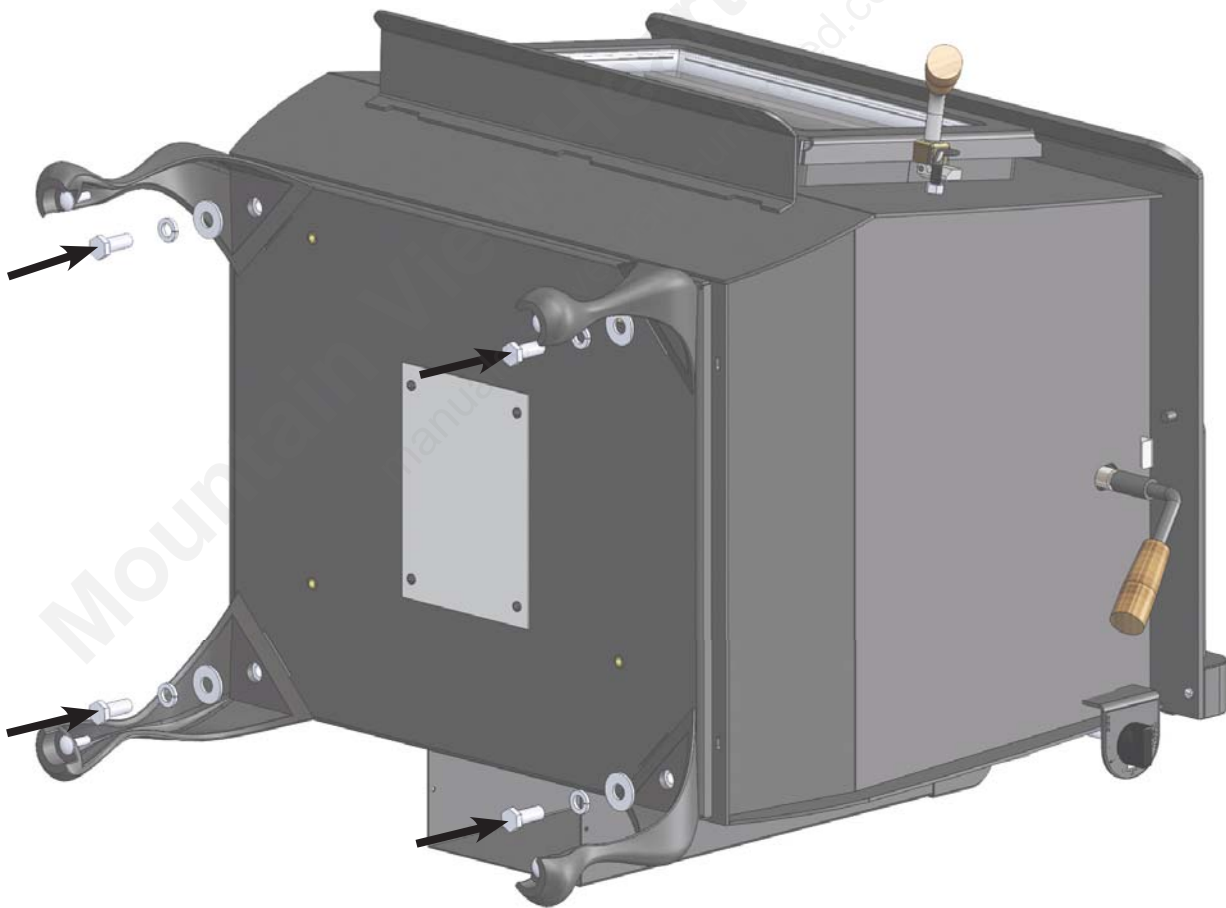
**Fig. 1****Fig. 2**

DOOR INSTALLATION AND CHANGE-OUT

To install the door upon stove installation or to change it out, follow these steps:

WARNING: DOOR IS HEAVY, PLEASE HOLD FIRMLY.

INSTALLATION

1. Align bottom door hinge hole with bottom firebox hinge pin.
2. Lower door onto bottom hinge pin, then align top door hinge hole with top firebox hinge pin.
3. Lower door onto pins until door hinge surface contacts firebox hinge surface.

NOTE: If your door has a gold or silver plating on it, please follow the instructions on the PLATED DOOR & TRIM CARE card found in the manual pack.

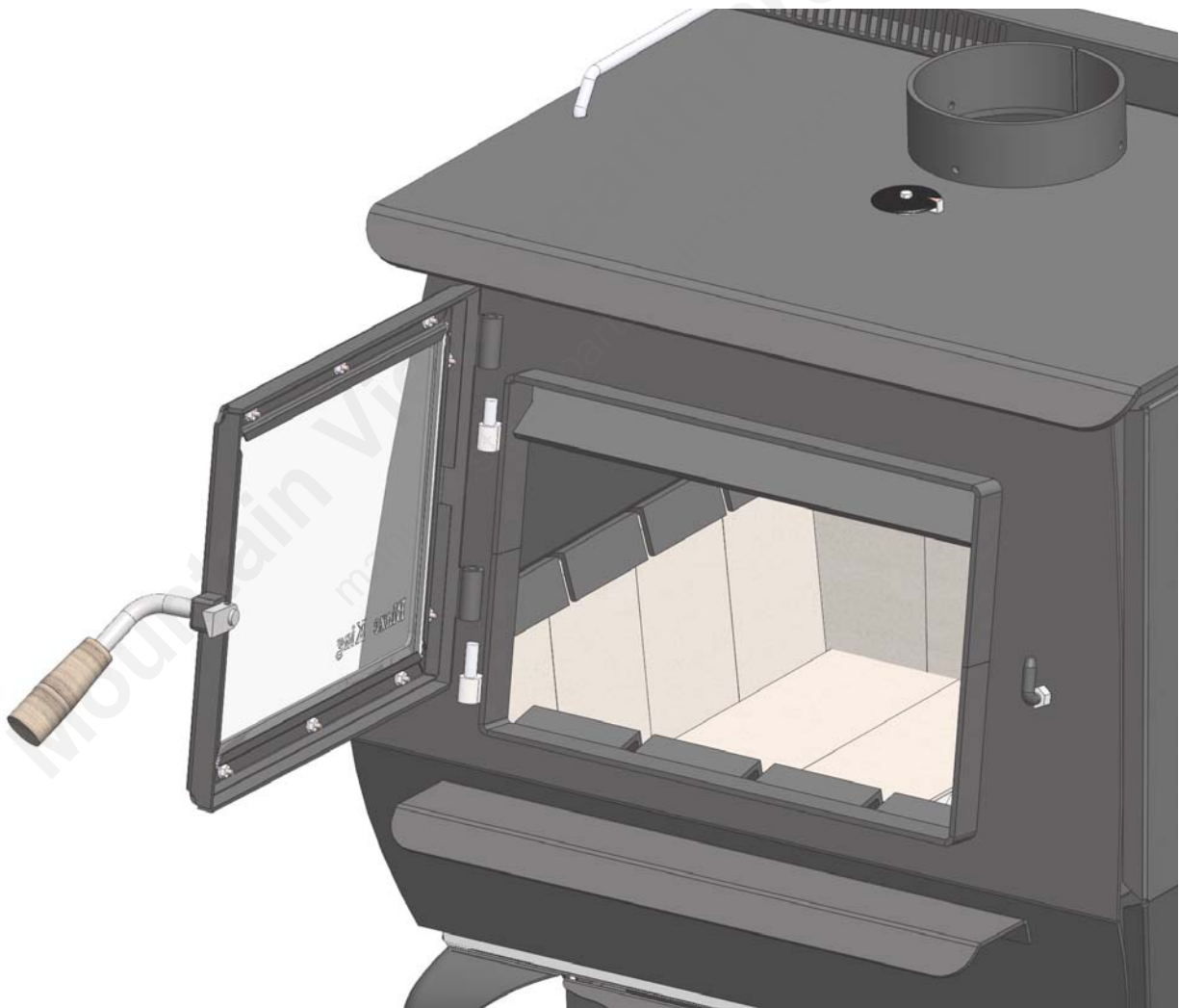

INTRODUCTION

All Blaze King free standing wood appliances are designed as radiant room space heaters. They have been designed and tested to be installed in insulated habitable rooms areas of your dwelling. The appliance has not been designed to be installed in a concrete uninsulated basement or in a shop/garage environment. Such applications may cause the thermostat to be unresponsive due the constant call for heat resulting in appliance being in a constant or over fire situation. Consequential damage from this type of operation will deem the warranty null and void.

All Blaze King wood appliances are designed to burn cord wood only. Dimensional timber off cuts, very low moisture content small diameter wood and pressed wood logs, when used in excess, may result in excessive internal firebox temperatures that can cause causing irreversible damage to the firebox's internal structure. Excessive temperatures can be caused by many small pieces of very low moisture content wood being used as a primary fuel source. This may be evident by warping or warped internal plates and retainers, possible cracking of the outer firebox and possibly premature failure of the catalytic combustor. All wood appliances should be cleaned out and inspected at the end of every burning season to identify if any internal components have been affected during the burning season. If problems are observed steps must be taken to identify and correct the problem before the subsequent burning season. Failure to do so will result in the warranty of the product being null and void.

YOUR FIRST FIRE!

The following pages contain information on the major components and operation of your heater. Please take time to read about them as it will give you a better understanding of how your appliance works. This understanding will help you to operate your appliance properly thus will extend the life of your appliance and allow you to get the highest efficiencies from your heater.

BYPASS

Your catalytic wood burning appliance has a bypass device to allow the smoke from the fire to temporarily bypass, or go around, the catalytic combustor. The bypass door is located inside the firebox at the top of the stove. The bypass is a steel plate door, hinged inside the stove, and is controlled by the bypass handle on the right side of the stove. When the handle is pointing at you, the bypass is open, when pointing away, it is closed. It is a clockwise rotation from open to closed.

NEVER OPEN THE LOADING DOOR WITHOUT OPENING THE BYPASS DOOR

Note: To ensure the bypass is closed push down on the bypass handle until you hear a positive click.

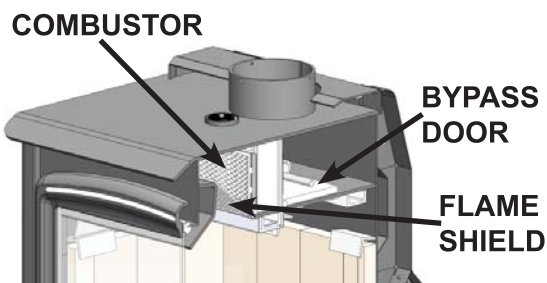

CATALYTIC THERMOMETER

This thermometer is located on the top of the stove. It's purpose is to show you if the combustor is active. Always operate the stove in the "active" zone. When the combustor is not active the stove will emit smoke and will not be efficient. For an accurate reading, turn fans off for approximately 10 minutes and then read the thermometer.



THERMOSTAT

The thermostat knob is located on the top right rear corner of the stove. It controls the burn rate of the stove. Any thermostat position between **LOW**(thin line) and **HIGH**(wide line) will produce the desired clean burning characteristics. However, since each installation is different, you may find it necessary to operate the thermostat to suit your situation. A **HIGH**(wide line) thermostat setting will produce maximum heat which is more than suitable for heating the average size home. All adjustments to the thermostat should be done gradually. When you first light the stove set the thermostat to **HIGH**(wide line) setting for 20-30 minutes, or until the fire is well established. Once the fire is established turn the thermostat to **MED**(middle of line) for 5 minutes and then to a **LOW**(thin line) setting or the desired setting. Too rapid an adjustment may cause the stove to operate improperly. The most common mistake new owners make is continually adjusting the thermostat.

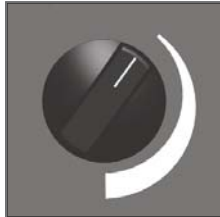
**LOW**(thin line)**MED**(middle of line)**HIGH**(wide line)**SELECTING WOOD****⚠ WARNING**

- **THIS APPLIANCE IS DESIGNED TO BURN NATURAL WOOD ONLY. DO NOT BURN TREATED WOOD, COAL, CHARCOAL, COLORED PAPER, CARDBOARD, SOLVENTS OR GARBAGE.**
- **HIGHER EFFICIENCIES AND LOWER EMISSIONS WILL GENERALLY RESULT WHEN BURNING AIR DRIED SEASONED WOODS, AS COMPARED TO WET, GREEN OR FRESHLY CUT WOODS.**
- **BURNING WET UNSEASONED WOOD CAN CAUSE EXCESSIVE CREOSOTE ACCUMULATION. WHEN IGNITED IT CAN CAUSE A CHIMNEY FIRE THAT MAY RESULT IN A SERIOUS HOUSE FIRE.**

Use dry seasoned wood, split and stacked and protected from rain for at least 24 months with a moisture content of 20% or lower. It takes a great deal of energy to evaporate the moisture contained in green wood and that energy will not be heating your house. Also, green or wet wood will greatly increase creosote problems. The only accurate method to determine moisture content in wood is to use a moisture meter. Never burn salt-water driftwood. It is very corrosive and will damage the firebox. Burning salty wood also voids the warranty.

This controlled combustion firebox has been designed for high efficiency and long burn times.

The proper time to add more wood is when the last charge has been reduced to a glowing charcoal bed and while the catalytic thermometer is still active range. There will be very little smoke at this stage in the burn cycle.

Both hardwood and softwood burn equally well in this appliance but hardwood, which is more dense, will weigh more per cord and burn a little slower and longer. Firewood should be split and stacked in a manner that air can get to all parts of it and covered in early spring to be ready for burning that fall.

The only accurate way to determine wood moisture is to purchase a moisture meter.

⚠ WARNING

- **NEVER START A FIRE UNLESS ALL BRICKS ARE CORRECTLY PLACED INSIDE THE FIREBOX. CHECK THE INSTALLATION INSTRUCTIONS CAREFULLY.**
- **ALWAYS OPEN THE BYPASS DOOR BEFORE OPENING THE LOADING DOOR.**
- **ONCE THE LOADING DOOR IS CLOSED, CLOSE THE BYPASS DOOR DIRECTLY AFTER THE CATALYTIC THERMOSTAT NEEDLE IS IN THE ACTIVE ZONE.**

HOW TO USE MOISTURE METERS

1. Take a random selection of around 3-4 logs per cubic yard or cubic meter.
2. Split each log down the middle.
3. In the center of log push pins of meter along grain - three measurements are taken on the freshly split surface: 2" or 5 cm in from each end of the log and in the middle of the split surface with sufficient contact (see figure).
4. Do this to all the logs and take an average of the readings (this will be only an approximate indication but a good guide).

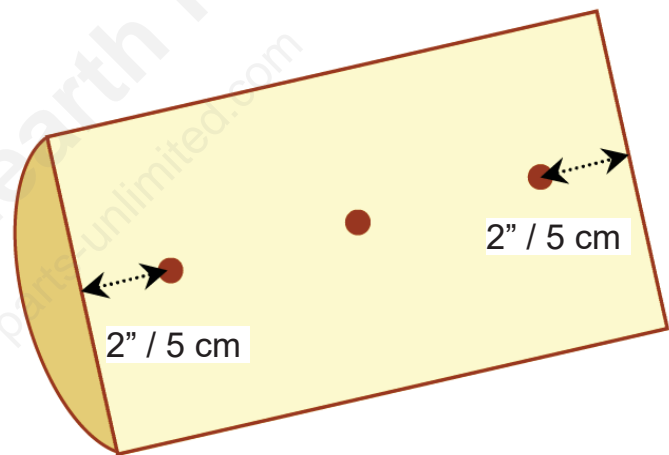

EFFICIENCY

Efficiency was determined using the method outlined in B415.1-10 test method. It is represented by the Higher Heating Value (HHV) as the fuel used during testing contains between 19% - 25% water moisture included in the total calculated fuel weight. (Other test methods such as LHV or Low Heating Value, does not take the water moisture into account).

Annual Fuel Utilization Efficiency (AFUE) attempts to represent the actual, season long, average efficiency of an appliance. HHV is the actual, calculated average efficiency obtained under test conditions. Using correctly seasoned wood is important when trying to gain efficiency. The more seasoned (dry) the wood, the higher the efficiency (less energy wasted on eliminating moisture during combustion). Operating your Blaze King at lower settings will result in higher efficiencies as the fuel will undergo a more complete combustion. For maximum efficiency, the appliance should be installed in a location that provides adequate intake/combustion air as well as a location that will allow for the straightest run of optimal chimney length to establish necessary draft .

LIGHTING THE FIRE

NOTE: As you heat up the stove for the first time, the paint will go through a curing process and will give off an odor. To minimize the inconvenience, burn the stove at a low temperature setting for several hours. It is advisable to open a door or window until the odor dissipates. You may also notice a change in color as the paint cures, this is normal and will appear uniform after subsequent firings.

1. **DO NOT USE A GRATE. BUILD THE FIRE DIRECTLY ON THE BRICK IN THE BOTTOM OF THE STOVE.**
2. Set the thermostat to **HIGH** (maximum) position and turn the fan(if fitted) **OFF**.
3. Open both the loading door and the bypass door (rotate the bypass handle forward).
4. Place 10 balls of non-glossy paper towards the front of the bottom of the firebox, or use a Blaze King fire starter puck, then stack 20 pieces of kindling on top of the paper in a crisscross fashion (leaving air gaps in between sticks).
5. Light the fire and allow it to get a good start while leaving the loading door cracked open (approximately 3 to 5 minutes). **DO NOT LEAVE THE STOVE UNATTENDED.**
6. Once the kindling is fully on fire, place two or three medium size logs onto the fire. Keeping the loading door unlatched, allow the logs to catch fire (approximately 5 minutes). **DO NOT LEAVE THE STOVE UNATTENDED.**
7. Once the logs are burning, latch the loading door shut **BUT** keep the bypass door open. Leaving the loading door open after the fire is well started may cause premature failure of the catalytic combustor.
8. When nearly all of the wood in the firebox is fully burning, finish loading the stove. Lay the wood as far back in the stove as possible. Latch the loading door shut and observe the catalytic thermometer. Once the needle is in the **ACTIVE ZONE**, close the bypass door (rotate the bypass handle backwards). Turning the thermostat down too soon may cause the fire to go out.
9. Let the fire burn, with the thermostat in a **HIGH** setting, for 20-30 minutes, or until the fire is well established. At that point, turn the thermostat down to the desired setting. It is good burning practice to burn the stove on **HIGH** for 20 to 30 minutes after every refuelling, this will help to condition the wood load for optimum combustion. The temperature in the stove and the gases entering the combustor must be raised to at least 500°(indicated by the thermometer needle in the **ACTIVE ZONE**) for catalytic activity to be initiated. During the start-up of a cold stove, a high fire must be maintained for at least 20-30 minutes. This ensures that the stove, catalyst, and fuel are all stabilized at proper operating temperatures. Even though it is possible for flue gas temperatures to reach 600° within 5 minutes of a fire being started. If the fire is allowed to die down immediately (thermostat set to a **LOW** setting too soon), it may go out or the combustor may stop working, indicated by the thermometer needle being in the **INACTIVE ZONE**. Once the combustor starts working, heat generated in it, by burning the exhaust smoke, will keep it working.
10. The fan (if fitted) can be turned on when the stove is hot or after the initial warm up period of 20-30 minutes.

Probably the least understood requirement in maintaining a good fire is that of establishing a good base of coals or embers. A good bed of hot coals or embers will maintain a more even temperature as well as getting the new load of wood started easily. Put as much wood into the stove as needed, practice will teach the amount of wood necessary to keep the fire going until the next reloading time. Don't be afraid to fill it completely if necessary. With the Blaze King automatic thermostat, the wood will only burn at the rate set on the thermostat. Once the full load is established, the stove should be left to complete the full burn cycle. This is evident by either a coal bed (ember bed) remaining or the catalyst's thermometer hovers just inside the active zone. This procedure will maximize the efficiency of the combustor as well as limit chimney emissions and smoke spillage.

⚠ WARNING**DO NOT USE THE APPLIANCE WITHOUT A COMBUSTOR****RELOADING PROCEDURE (with the catalyst temperature in the ACTIVE ZONE)**

1. Have your next load of wood ready before beginning. Turn the thermostat to **HIGH** and the fan(if fitted) **OFF**. Wait 2 minutes for the air flow to stabilize.
2. Open the bypass door (rotate the bypass lever forward, on Princess Insert pull handle up) and again wait 2 minutes for the air flow to stabilize.
3. Unlatch the loading door and open just a crack to allow the ambient room air to be introduced to the firebox, this may take a few seconds to stabilize.
4. Slowly open the loading door and proceed to reload the firebox. If you experience excessive smoke spillage, slightly close the loading door to re-establish a draft through the chimney.
5. Once loaded, latch the loading door shut and close the bypass door (rotate the bypass handle backwards, on Princes Insert push handle down). Let the fire burn on the **HIGH** thermostat setting for 20 to 30 minutes **OR** until the fire is very well established. At that point, turn the thermostat down to the desired setting. Keep in mind you may not see a large amount of flame activity in the lower thermostat setting. The thermometer needle will remain in the active zone indicating that the burn cycle is continuing.
6. Should you burn the stove on a very low setting for extended periods of time, you will begin to see creosote deposits forming on the glass door. To remove these deposits, simple run the stove on **HIGH** for approximately 30 minutes. The **HIGH** setting will burn off most of the deposits

As every pile of wood is different you will learn, over time, which settings are necessary to achieve the optimal fire. This will be based on the type of wood, installation, weather conditions and the desired room temperature.

RELOADING PROCEDURE (with the catalyst temperature still in the INACTIVE ZONE)

Follow the procedure for "LIGHTING THE FIRE" on the previous page.

OPTIMAL THERMOSTAT SETTING

Any thermostat position between **LOW** and **HIGH** will produce the desired clean burning characteristics. However, since each application can vary, you may find it necessary to operate the thermostat to suit your application. A thermostat setting on **HIGH** will produce a maximum heat which is more than suitable for heating the average size home and offer the cleanest door glass.

1. Starting the fire. Each stove, home, installation, chimney installation, and homeowner combination works a little differently. The first several times you fuel the stove, it may not react as you expect. A little experimentation may be needed to find the right combination of fuel and thermostat setting to achieve the maximum efficiency. This is one of the joys of burning wood. You, the wood burner, make it work. And you can see what happens as it is working. Be patient, the air / fuel mixture and temperature must be stabilized before maximum combustion efficiency can be achieved.
2. As the combustor temperature (as indicated by the thermometer on top of the stove) passes into the active zone, further adjustment to achieve the desired room temperature should be made in small increments for the most effective cleaner burning operation. Changes should be made as few times each day as possible. When the thermostat knob is moved from high to low, more gases are produced, so the combustor has more fuel; consequently the combustor thermometer may register a higher heat for several hours after the thermostat is turned down.
3. Keep hot coals active so when you reload the stove you will reduce the time necessary to maintain an active combustor.
4. The thermostat is set at the factory. **DO NOT TAMPER WITH THE THERMOSTAT**, this will result in a malfunctioning thermostat.

FAN OPERATION

The fan(if fitted) should be off until the stove reaches normal operating temperatures. After approximately 30 minutes, the fan speed adjustment should match the thermostat control setting, i.e. if your stove is set at medium then your fan should also be set at medium, low—low, high—high etc.. We recommend the use of an optional fan system on all our wood stoves. The fan system recirculates the room air over the hot surfaces of your stove and helps spread this super heated air around your home.

ICE - FORMATION AND PREVENTION

Most of what you see coming from the chimney of a properly operating catalytic appliance is water vapor. In extremely cold weather - and with some exterior chimneys - this vapor may freeze in the chimney to the point of actually blocking the chimney and extinguishing the fire. In such weather, occasionally burn the appliance for 4 or 5 minutes with the thermostat setting on **HIGH** to melt any possible ice buildup.

WOOD BURNING IN THE SHOULDER SEASON

There are things to consider if you decide to light a fire in the spring and fall or when the outside temperature is milder, perhaps 55°F to 70°F (13°C to 21°C).

As you light the fire, with the loading door open, you may notice spillage, this is when a small amount of smoke comes back into the living space. When your fire begins to warm the chimney and the draft improves, spillage is greatly reduced. After a short period of time you can adjust the thermostat to a **LOW** setting and maintain a comfortable temperature in your home.

In reducing the thermostat setting you have also reduced the flue temperatures and your chimney begins to cool down. At this time the amount of draft is also decreasing and spillage may occur. The differences between the flue temperature and the outdoor air temperatures causes your chimney to draw and vent the flue gasses to the outside. This air movement, sometimes referred to as Stack Effect, is also influenced by air density and moisture differences. Small temperature differences produce less draw in your chimney system than large temperature differences.

General Rules for burning in the shoulder season:

- Run your appliance on high for 30 minutes after start up and reloading.
- Slowly turn the thermostat down to the desired heat setting.
- The heat setting needs to be high enough to keep the thermometer in the active zone.
- If the thermometer does not stay in the active zone turn the thermostat to a higher setting. Wait 15 minutes then confirm that the thermometer remains in the active zone. Repeat as needed.
- If your appliance is producing too much heat, build smaller hotter fires.
- Build smaller hotter fires on milder days in the spring and fall.

It is important to periodically monitor the operation of the catalytic combustor to ensure that it is functioning properly. A non-functioning combustor will result in a loss of heating efficiency, and an increase in creosote and emissions. Following is a list of items that should be checked on a periodic basis:

- Combustors should be visually inspected at least three times during the heating season to determine if physical degradation has occurred. Actual removal of the combustor is not recommended unless more detailed inspection is warranted because of decreased performance. Refer to “CATALYTIC COMBUSTOR TROUBLESHOOTING” on next page.
- This catalytic heater is equipped with a temperature probe to monitor catalyst operation. Properly functioning combustors typically maintain temperatures in excess of 500°F (indicated by the thermometer needle in the active zone), and often reach temperatures in excess of 1000°F. If catalyst temperatures fall below 500°F (indicated by the thermometer needle in the inactive zone), refer to next step and to “CATALYTIC COMBUSTOR, TESTING” below.
- You can get an indication of whether the catalyst is working by comparing the amount of smoke leaving the chimney when the smoke is going through the combustor and catalyst light-off has been achieved, to the amount of smoke leaving the chimney when smoke is not routed through the combustor (bypass mode):
 - Light the appliance as per the lighting instructions (see “LIGHTING THE FIRE”). With smoke routed through the catalyst, go outside and observe the emissions leaving the chimney.
 - Open the bypass mechanism, wait approximately 15 minutes, and again observe the emissions leaving the chimney. Significantly more smoke will be seen when the exhaust is not routed through the combustor (bypass mode). Some smoke may be visible shortly after you start the fire and shortly after reloading the fire. Allow 20 to 30 minutes for the fire to stabilize before making observations.

CATALYTIC COMBUSTOR, TESTING

Light the fire as per the lighting instructions (see “LIGHTING THE FIRE”). Then set the thermostat knob on a MED setting. When the fire is well established (within one to three hours) turn the thermostat knob between **LOW** and **MED**. A properly operating combustor will remain active, and the combustor thermometer will remain in the “active” zone until the wood load is mostly consumed. A “tired” or “dead” combustor will, with the thermostat on **MED** or lower, go out completely, and the thermometer needle will fall into the “inactive” zone. Repeat this procedure several times over several days (Remember that the combustor thermometer has a built-in lag of 4-8 minutes.) If, after several test burns, the thermometer will not indicate an “active” combustor, it may require cleaning or replacement. It is also possible that the thermometer, itself, may not be reading accurately. Before condemning the combustor, read “THERMOMETER”. If, after cleaning has been performed, your combustor is still not working you can Contact Blaze King for a replacement combustor. Please read “REPLACEMENT PARTS” section in this owners’ manual.

CATALYTIC COMBUSTOR, CLEANING

Under certain conditions, ash particles may become attached to the face of the combustor. These may be seen while the combustor is in the glowing stage, or when the fire is out. Any deposit on the visible face of the combustor should be removed. Wait until the fire is out and the appliance is cold before performing any cleaning. Brushing the combustor with a soft bristle paint brush will remove some deposits. Passing a vacuum cleaner wand or brush near the face of the combustor will remove most deposits. (Hot ash in a vacuum cleaner bag will burn, may melt the vacuum or cause a house fire. Exercise caution and never clean the appliance when the appliance or ashes are hot.) Never scrape the combustor with any hard tool or brush. Never run pipe cleaner through the individual cells of the combustor. This is not needed, and may do more harm than good. Limit cleaning to the face of the combustor. **NOTE: Never remove a combustor without approved combustor gasket in hand as original gasket will fall apart when removed from appliance.** Remember to re-install the Flame Shield (the perforated plate) in same position it was found. TIP: A hot fire will usually prove to be the best method of cleaning the combustor of deposits.

CATALYTIC COMBUSTOR, TROUBLESHOOTING

PROBLEM - CREOSOTE PLUGGING

Possible Cause: Burning materials that produce a lot of char and fly-ash.

Solution: Do not burn materials such as garbage, gift wrap, or cardboard.

Possible Cause: Burning wet, pitchy woods or burning large loads of small diameter wood with the combustor in the operating position without the thermostat needle in the active zone.

Solution: Burn dry, seasoned wood, don't engage the bypass until the temperatures are high enough to initiate light-off (indicated by the thermostat needle in the active zone).

Possible Cause: Combustor not functioning. If proper burning procedures have been followed to no avail, the combustor is not functioning.

Solution: Replace the combustor with a genuine Blaze King combustor (failure to do so will void your warranty).

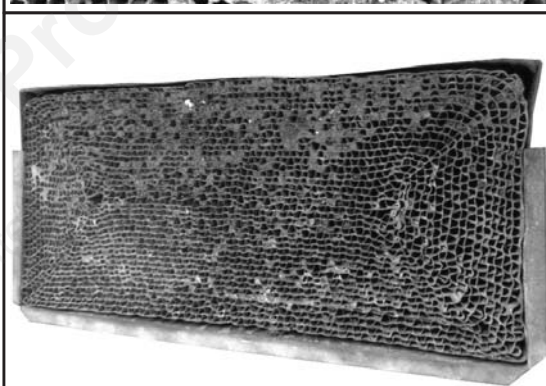
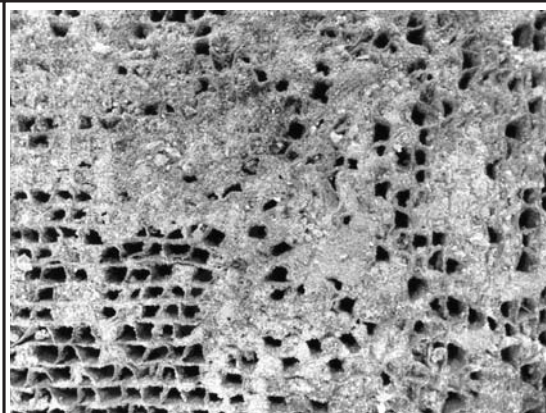

PROBLEM - CATALYST PEELING

Possible Cause: Extreme temperatures (above 1800°F, or 1000°C.) at combustor surface can cause the catalysts to peel. Over firing and flame impingement on the combustor are primary causes. Minor peeling photo shows minor peeling that is normal and does not affect function. Severe peeling photo shows that are closed or plugged.

Solution: Avoid extreme temperatures and flame impingement. If peeling is severe, remove and replace combustor.

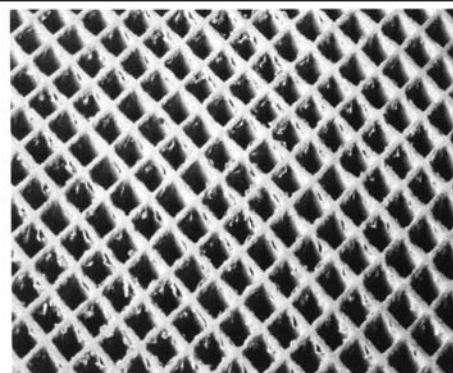

Minor Peeling

PROBLEM - CATALYST DEACTIVATION

Possible Cause: Burning large quantities of trash, pressure-treated lumber, or painted woods.

Solution: Burn quality woods available in your area. If you decide the catalyst has been deactivated, replace combustor with a genuine Blaze King combustor (failure to do so will void your warranty).

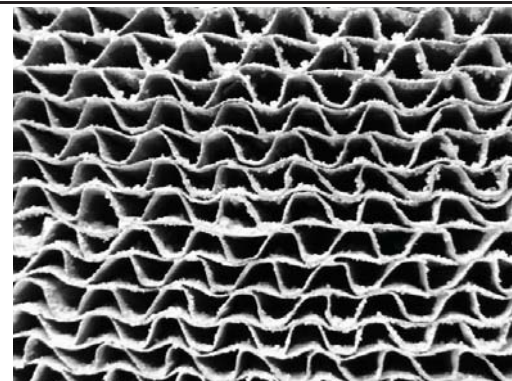

Severe Peeling

PROBLEM - CATALYST MASKING

(The catalyst is coated with a layer of fly-ash or soot which prevents catalytic activity)

Possible Cause: Accumulation of fly-ash

Solution: Brush cooled combustor with a soft-bristled brush or vacuum lightly at least once per burning season.

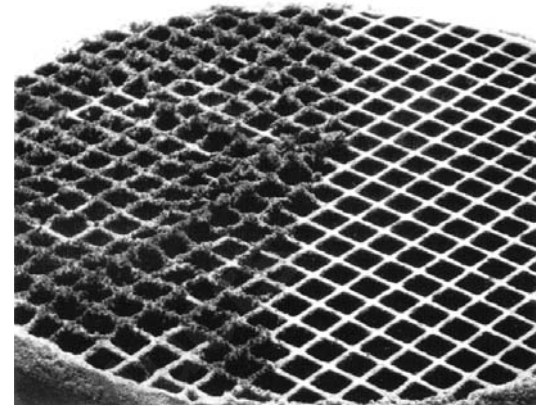
**PROBLEM - THERMAL CRACKING**

Possible Cause: Normal operation, as long as the combustor remains intact.

Solution: If cracking causes large pieces to fall out, replace the combustor.

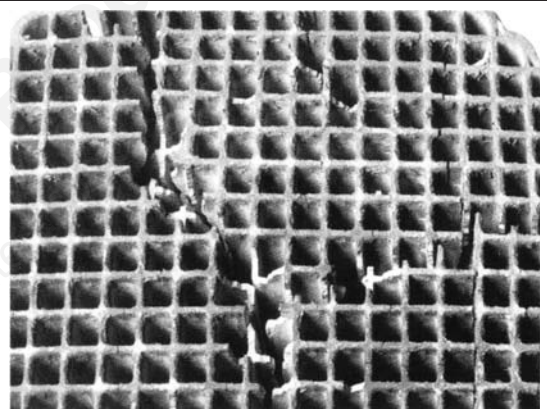
**PROBLEM - MECHANICAL CRACKING**

Possible Cause: Mishandling, abuse, or operating without a properly gasket sealed combustor.

Solution: Handle with care

Possible Cause: Distortion of holding collar.

Solution: Combustor should be held firmly in its can. It should slide easily into and out of the holding collar of the stove. If severe cracking has resulted in loss of large chunks of combustor, replace combustor. Also replace any warped stove parts.

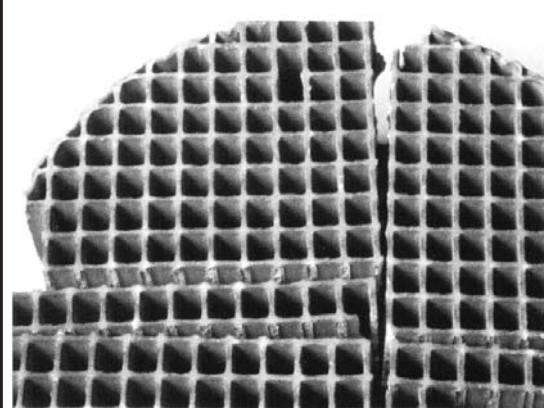
**PROBLEM - CRUMBLING**

Possible Cause: Air leaks

Solution: Inspect door gasket, see "MAINTENANCE" on page 38.

Possible Cause: High draft

Solution: Do not exceed .06" of water draft.

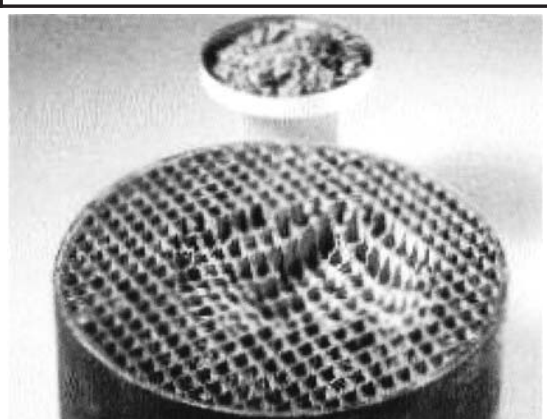

CATALYTIC COMBUSTOR, REPLACEMENT**BLAZE KING RECOMMENDS YOUR DEALER PERFORM THIS TASK**

The catalytic thermometer on top of the stove should read in the active zone after the stove has been in operation for several hours. If the thermometer's indicator needle does not stay in the active zone, even with a hot fire, over a 7-10 day period of regular use, the combustor may need replacement or cleaning, see "CATALYST MONITORING". If the combustor needs replacing then discontinue use of the appliance until the combustor is replaced. If the combustor must be examined or replaced contact your Blaze King dealer.

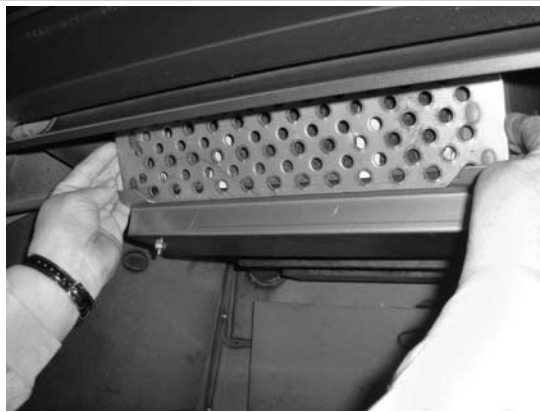

1. The removal of a Blaze King Catalytic combustor requires a small flat blade screwdriver or pocket knife. The stove fire must be out for at least 12 hours prior to the removal process. A combustor can reach 1400°F and hold high temperatures for several hours even after the fire is out. After waiting 12 hours, first remove the flame shield by simply lifting the shield off the two tabs at either side. Pay particular attention to orientation as there is a top and bottom edge to the flame shield.



2. Once you remove the flame shield, you'll find the combustor. The honeycomb combustor can be made of different materials such as cordierite, mulite or even stainless steel. They are all the same with regard to removal and caution should be taken so as to not drop or damage the combustor. If your combustor has never been cleaned according the manufacturers directions, you may wish to clean the combustor before replacing it with a new combustor, see "CATALYTIC COMBUSTOR CLEANING".



3. The combustor has a metal tab across the bottom and on each side of the combustor. Using a flat blade screwdriver or pocket knife blade, slide the blade behind the metal tab and the heavy steel dome of the stove. The dome is the housing that surrounds the combustor. Apply slight pressure until the combustor begins to move forward, about 1/4". Repeat the process on the opposite end tab. By working back and forth the combustor will work free of the dome housing. It is normal for the gasket surrounding the metal band to fall apart during this process. New combustors are shipped with a new gasket.

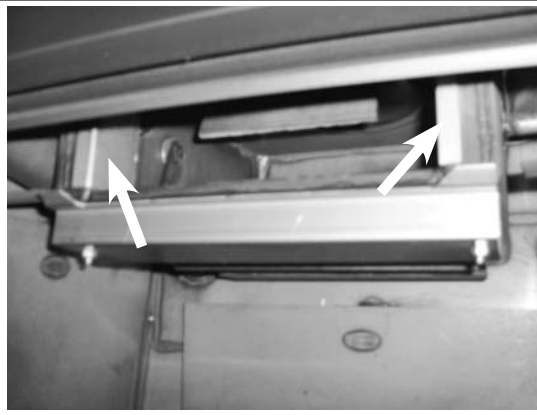

4. Now that the combustor has been removed you'll be able to see one stainless bypass retainer on each side. These can remain in place and do not need to be removed. These clips are not fixed in position and can fall into the firebox. Make sure they are in position before replacing the combustor. Using the same screwdriver or pocket knife, scrape any old gasket from the surface areas of the dome. The dome is the housing that surrounds the combustor. If you clean your existing combustor, you'll need to order replacement combustor gasket. It is always a good idea to have a spare combustor gasket on hand prior to performing any maintenance. If you purchase a new combustor a new gasket will already be applied to the combustor.

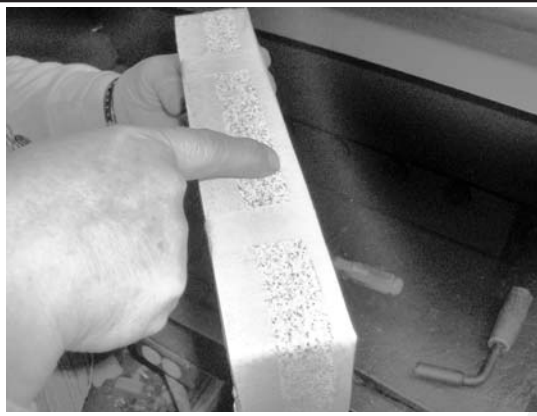

5. This new combustor already has the gasket installed. Note the 1" wide masking tape. This tape will help to keep the leading edge of the gasket from snagging during installation. If you've cleaned your combustor, wrap the combustor gasket as you see here and use the 1" masking tape around the perimeter front and rear. During the first fire the masking tape will burn off and the combustor gasket will swell providing a tight seal. It is this tight seal that improves efficiency and performance. You should never burn your stove without a combustor gasket installed.



6. Since the combustor is only 2" deep, there is ample room to lift the new combustor into place. **REMEMBER TO HAVE THE TAB ACROSS THE BOTTOM EDGE OF THE COMBUSTOR AS IT IS INSTALLED.** Slowly push the combustor in at the top apply even pressure to the left and right corners. This will allow for a better view of the bottom edge for the final fitting. **DO NOT FORCE THE COMBUSTOR INTO THE DOME. TAKE YOUR TIME AND WORK IT INTO PLACE SLOWLY.**

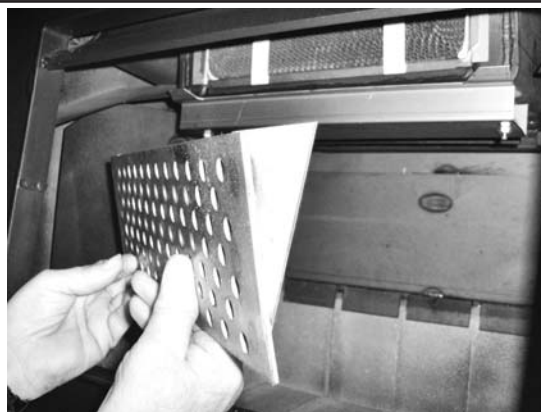

7. Once the combustor is installed completely so that all three tabs are touching the face of the dome, replace the flame shield. Note the brackets welded to the back flame shield are shaped like a triangle. The point of the triangle should face down when installed correctly. Never operate your stove without the flame shield in place. The flame shield will protect the face of the combustor against damages from wood when loading and other possible damages that can occur during the cleaning process.

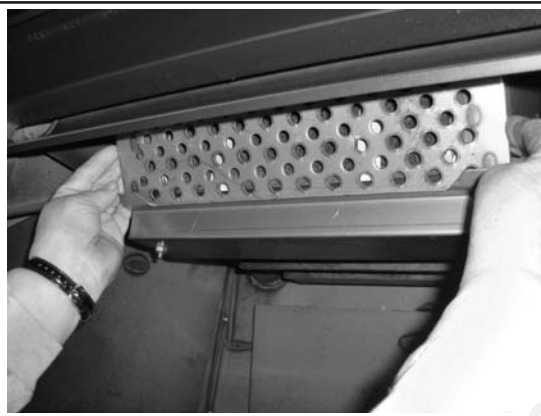

8. The flame shield will rest on the two tabs located on the dome guard and lean slightly forward. Now that your combustor has been installed you can relight your stove. You will continue to receive excellent efficiency and clean burning for years to come. A few reminders, never burn anything other than dry, seasoned cordwood. Burning anything else may contaminate or ruin your new combustor. Also remember to keep your front loading door gasket seal properly adjusted, see "LOADING DOOR TENSION ADJUSTMENT". Doing so will improve burn times and extend combustor life span.

The combustor supplied with this heater is either a Z4400G metal combustor. Consult the catalytic combustor warranty also supplied with this wood heater. Warranty claims should be addressed to:

in Canada	in USA
Blaze King Industries / Valley Comfort Systems Warranty Department, 1290 Commercial Way Penticton, BC Canada V2A 3H5, Ph: 250-493-7444	Blaze King Industries Warranty Department, 146A Street Walla, Walla, Washington 99362, Ph: 509-522-2730

RUN-AWAY OR CHIMNEY FIRE**⚠ WARNING**

A CHIMNEY FIRE CAN PERMANENTLY DAMAGE YOUR CHIMNEY SYSTEM. THIS DAMAGE CAN ONLY BE REPAIRED BY REPLACING THE DAMAGED COMPONENT PARTS. CHIMNEY FIRE DAMAGE IS NOT COVERED BY THE LIMITED WARRANTY.

CAUSES:

1. Using incorrect fuel, or small fuel pieces which would normally be used as kindling.
2. Leaving the door ajar too long and creating extreme temperatures as the air rushes in the open door.
3. Improperly installed or worn gaskets.
4. Creosote build up in the chimney.

SOLUTIONS:

1. Do not burn treated or processed wood, coal, charcoal, colored paper or cardboard.
2. Be careful not to over fire the appliance by leaving the door open too long after the initial start-up.
3. Replace worn, dried out (inflexible) gaskets.
4. Have your chimney cleaned regularly.

WHAT TO DO IF A RUN-AWAY OR CHIMNEY FIRE STARTS:

1. Close the draft fully (lowest position) by shutting off thermostat, and make sure firebox is closed tightly.
2. Call the local fire department.
3. Examine the chimney, attic and roof of the house, to see if any part has become hot enough to catch fire. If necessary spray with a fire extinguisher or water from a garden hose.
4. Do not operate the appliance again until you are certain the chimney has not been damaged.

CREOSOTE FORMATION AND REMOVAL

When wood is burned slowly, it produces tar and other organic vapors which combine with expelled moisture to form creosote. These vapors condense in the relatively cooler chimney flue of a slow burning fire and when ignited, make an extremely hot fire. Check your chimney for creosote and soot regularly, until a safe frequency for cleaning is established. The chimney connector and chimney should be inspected regularly during the heating season to determine if a creosote build up has occurred. Be aware that the hotter the fire, the less creosote is deposited.

If accumulation is excessive, clean the chimney. You may want to call a professional chimney sweep to clean it. Both the chimney and the appliance have to be cleaned at least once a year or as often as necessary. Have a clearly understood plan to handle a chimney fire.

CHIMNEY MAINTENANCE

CHIMNEY MAINTENANCE

The most efficient method to sweep the chimney is using a hard brush. Brush downwards so soot and creosote residues will come off the inner surface and fall to the bottom of the chimney where they can be removed easily.

The chimney must be checked regularly and if creosote has accumulated, it must be removed without delay. Cleaning on a regular basis should be sufficient during the coldest months. **ENSURE THE BYPASS DOOR IS OPEN PRIOR TO CLEANING THE CHIMNEY SO THE SOOT AND CREOSOTE FALLS INTO THE FIREBOX.**

Chimney / Flue Inspection:

1. The chimney should be inspected regularly during the heating season.
2. If possible, the chimney should be dismantled and cleaned.
3. The chimney should be inspected for possible damage.
4. If it is in good condition, put the chimney back in place; otherwise, it must be replaced.

FIRE EXTINGUISHERS AND SMOKE DETECTORS

All homes with a solid fuel burning appliance should have at least one fire extinguisher in a central location, known to all, and at least one smoke detector in the room containing the appliance. If it sounds an alarm, correct the cause but do not de-activate or relocate the smoke detector.

ASH REMOVAL

This appliance is required to be cleaned frequently because soot, creosote and ash may accumulate. Wait until the appliance is fully cooled off before the removal of ashes. **ALWAYS REMOVE THE ASH BUCKET IMMEDIATELY AFTER FILLING.** Ashes should be removed any time they come within one inch of the door opening. It is not necessary or advisable to completely remove all of the ashes when cleaning this appliance. Wood burns best in a bed of ashes 1/2" thick. Ashes should be placed in a metal container with a tight fitting lid. The closed container of ashes should be placed on a noncombustible floor or on the ground (outside), well away from all combustible materials, pending final disposal. If the ashes are disposed of by burial in soil or otherwise locally dispersed, they should be retained in the closed container until all cinders have thoroughly cooled. Other waste shall not be placed in this container.

WARNING

NEVER STORE HOT ASHES IN A GARAGE OR BASEMENT. HOT ASHES WILL GENERATE CARBON MONOXIDE AND / OR FLAMMABLE GASES. THESE GASES MAY CAUSE SUFFOCATION AND POSSIBLE DEATH.

LOADING DOOR GASKET INSPECTION

Inspect the door gasket for physical deterioration, missing sections or obvious leakage. The appliance front should make a groove in the gasket material - one side of the groove (toward the inside) will often be dark or black, and the other side (toward the outside) should be light or white. Dark smudges on the outside of the groove may indicate an air leak. If the groove is very shallow or missing, or if there is a heavy ash or creosote deposit along the bottom edge of the gasket, it may need to be replaced. Frayed or broken gasket material, or a gasket that is hard and unyielding, will also indicate need for replacement. Any time a piece of gasket is missing or is broken anywhere, the entire gasket must be replaced.

To check the gasket further, wait until the appliance is cooled and insert a piece of paper (a dollar bill will work) into the door opening and close and latch the door. Obvious resistance should be felt when pulling the paper out. Repeat this check several times around the perimeter of the door.

LOADING DOOR GASKET REPLACEMENT

BLAZE KING RECOMMENDS YOUR DEALER PERFORM THIS TASK

1. If the door gasket is to be replaced, be sure you have Blaze King 7/8" fiber glass gasket ready to re-install, as well as high temperature adhesive. See your Blaze King dealer.
2. Be sure the fire is out and the stove has cooled down. The door should be removed by lifting up and out, off of the hinge pins. Then lay the door flat.
3. With a pair of pliers, pull the old door gasket out of the channel and dispose of it.
4. Thoroughly clean out the channel so the new silicone adhesive will adhere and the gasket will fit smoothly.
5. Dry fit the new gasket first to ensure proper fit. Do not stretch or cut the gasket. Distribute the gasket evenly around the frame.
6. Run a small bead of a high temperature silicone adhesive along the center of the channel. **DO NOT USE HOUSEHOLD SILICONE CAULKING.** High temperature silicone may be obtained from wood stove dealer.
7. Start the new gasket in the lower right corner. Do not stretch or cut the gasket. Distribute the gasket evenly around the frame.
8. Allow the adhesive to dry before closing the loading door. The loading door tension may need to be adjusted, see "LOADING DOOR TENSION ADJUSTMENT".
9. Check the fit of the door gasket. Insert a narrow strip of paper into the door opening and close and latch the door. Obvious resistance should be felt when pulling the paper out. Repeat this check several times around the perimeter of the door. If no resistance is felt, adjust door latch catch, see "LOADING DOOR TENSION ADJUSTMENT".
10. A tight sealing door extends the burn times & protects the combustor.

BYPASS DOOR GASKET INSPECTION

If you do not hear a positive click when closing your bypass door first try adjusting the tension, see number 9 below. If the seal is not tight after making the adjustment, the gasket may need to be replaced.

BYPASS DOOR GASKET REPLACEMENT**BLAZE KING RECOMMENDS YOUR DEALER PERFORM THIS TASK**

1. You will require THERMOSEAL® 1000SF high-temperature resistant cement and Blaze King 5/8" dense fiber glass gasket. See your Blaze King dealer. You will also require masking tape and combustor gasket as disassembly of the combustor will result in a damaged combustor gasket.
2. Be sure the fire is out and the stove has cooled down.
3. You will need to remove the liner from the collar of the stove, and have the ability to see straight down into the stove box through the collar.
4. Please follow steps on "CATALYTIC COMBUSTOR, REPLACEMENT" on how to remove your combustor.
5. To remove the bypass door, move the bypass rod out of the way using the bypass handle on the side of the stove. Looking down through the collar, lift one end of the bypass door for clearance to turn inside the top assembly. Once the bypass plate is in this position, remove the plate through the combustor opening.

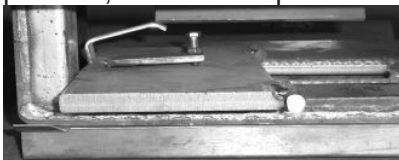

**BYPASS DOOR REMOVAL
THROUGH COMBUSTOR OPENING**

6. Remove the old gasket and apply the THERMOSEAL® 1000SF high-temperature resistant cement along the door opening edge.
7. Place the gasket along the cement, and tap it in to seat it securely in the channel.
8. Reverse method of removing bypass door to put it back in place.
9. Prior to reconnecting the liner, you will need to adjust the bypass ramp bolt. You must first loosen the retaining nut located under the head of the adjustment bolt. Then using a 7/16" box wrench, tighten the bolt until the bypass handle, when closed, has a slight cam-over feel. Do not over tighten.
10. Secure bolt adjustment by tightening the 7/16" nut against the ramp as seen in the photo to the left. Now work the bypass handle several times to make certain the bypass operation is smooth and working properly. When you are satisfied with the operation of the bypass, please lower the venting.
Important: Apply high temp anti-seize lubricant to the under side of the bypass ramp where the rod contacts.
11. Please follow steps 5-8 in "CATALYST MONITORING" to return the combustor into place. Please note that if the gasket of the combustor is damaged, it will have to be replaced.

**VIEW OF BYPASS DOOR
AND CRANK
THROUGH COLLAR**



COMBUSTOR OPENING



BYPASS DOOR OPENING

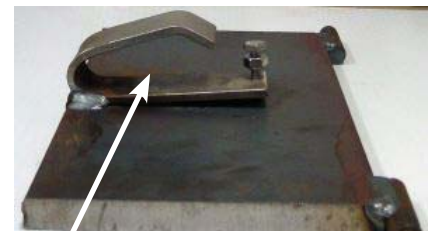

**APPLY LUBE TO THE UNDER
SIDE OF THE BYPASS RAMP**

DOOR GLASS GASKET INSPECTION

When the appliance is cold, hold the glass by placing the palm of each hand on either side of the glass. Press firmly and try to move the glass. If the glass moves the door glass retainers may need to be tightened or the door glass gasket may need to be replaced.

1. Inspect the door glass gasket. If the gasket is frayed or missing sections replace the gasket.
2. Inspect the glass retainers and ensure the screws holding the retainers in place are tight. Hand tighten plus 1/4 turn. Do not over tighten.

DOOR GLASS GASKET REPLACEMENT

BLAZE KING RECOMMENDS YOUR DEALER PERFORM THIS TASK

1. You will require Blaze King glass gasket and Blaze King door gasket. Please see your Blaze King dealer.
2. Remove the old glass gasket.
3. Starting at the corner opposite of the “Blaze King” logo, carefully wrap the gasket around the edges, pressing firmly onto the sides of the glass with the gasket centered on the edge. Finish the wrapping with a 1/2” overlap. Ensure the thickness of the gasket remains consistent and uniform.
4. Install glass with the “Blaze King” logo to the lower left corner of the door. Install the glass retainers with original fasteners. Ensure the glass is parallel to the frame and tighten the fasteners evenly.
5. Follow steps on “**LOADING DOOR GASKET REPLACEMENT**”.



DOOR GLASS, CLEANING

The best way to keep the glass clean is to leave the appliance on high burn for a period of time after each reloading. The moisture which is driven from a new load of wood contributes much of the creosote on the inside of the glass. Removing that moisture at the beginning of the burn cycle helps to keep the glass clean. Leaving the thermostat on a higher setting for 30 minutes to an hour before turning to low for an overnight burn will also help. Heavier deposits may require hand cleaning. Manual glass cleaning should be done when the appliance and glass are cool. **DO NOT CLEAN THE GLASS WHILE IT IS HOT. WARNING: Do not use abrasive cleaners to clean the glass.** Use a soft cloth. After using any cleaner, thoroughly rinse the glass with water to remove any deposits left by the cleaner. Failure to remove all traces of glass cleaner will result in the glass cleaner residue baking on. This residue may be very difficult to remove.

LOADING DOOR TENSION ADJUSTMENT

To tighten the seal, use a 9/16" wrench to loosen retainer nut on the outside and tighten nut on inside firebox to move latch catch in (see figure beside). Secure retainer nut and (repeat) paper test. (see "LOADING DOOR GASKET INSPECTION")

Use penetrating oil if necessary to make turning easier.
DO NOT FORCE !!

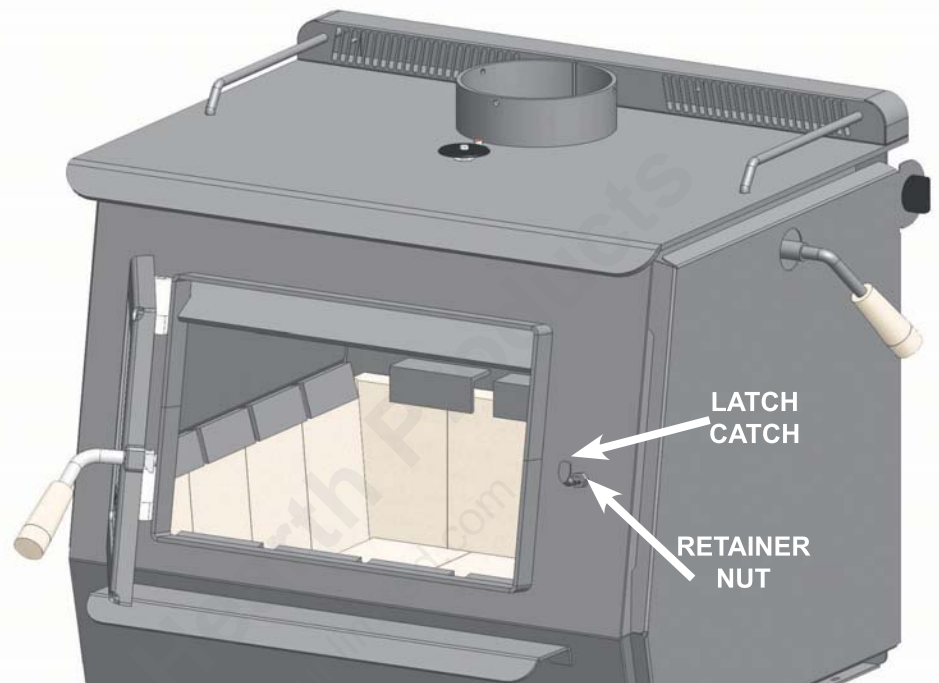
**⚠ WARNING**

DO NOT OPERATE THIS WOOD STOVE IF THE DOOR GASKET IS MISSING OR DAMAGED DANGEROUS OVER FIRING CAN OCCUR WHICH CAN DAMAGE THE APPLIANCE OR IGNITE CREOSOTE IN THE CHIMNEY, POSSIBLY CAUSING A HOUSE FIRE. IF ANY PART OF THE WOODSTOVE OR FLUE SYSTEM IS GLOWING THE STOVE IS BEING OVER FIRED.

OPTIONAL FAN ASSEMBLY

Routine maintenance of the OPTIONAL Fan Assembly on the back of the stove is not required. However, should it become necessary to replace an individual fan or rheostat, contact your local dealer.

THERMOMETER

The combustor thermometer tells you what was happening 4-8 minutes ago, and remember, it is only an indication of the temperatures of the gasses after they pass through the combustor. The thermometer probe, the part that fits into the stove, must be cleaned at least once a year. Lift it from the stove (be careful, it may be hot) and wipe or scrape it clean. At room temperature, away from the stove, the indicator should point near the bottom of the "Inactive" zone. If, after several years use, you find that the needle no longer points to the bottom of the "Inactive" zone when the thermometer has been at room temperature for 10 minutes or longer, it may need adjustment. Holding the probe with a pair of pliers, loosen the bolt on the top of the dial. Turn the dial to align the pointer with the bottom of the "Inactive" zone, then retighten the bolt.

NOTE: IF YOUR BLAZE KING IS EQUIPPED WITH FANS, TURN OFF FANS AND WAIT 10 MINUTES PRIOR TO READING CATALYTIC THERMOMETER INDICATOR. AIR MOVEMENT ACROSS THE TOP OF THE STOVE MAY PROVIDE FALSE READING.

THERMOSTAT

This wood heater thermostat has a manufacturer-set minimum low burn rate that must not be altered. It is against federal regulations to alter this setting or otherwise operate this wood heater in a manner inconsistent with operating instructions in this manual. If the thermostat malfunctions contact your dealer for replacement by a qualified installer.

Your Blaze King is designed to allow a wide selection of heat output levels. If you begin to lose control of the amount of heat the stove is emitting, determine the cause early so that major problems may be avoided.

The six major needs of a well-controlled fire are:

1. Knowledgeable operator.
2. Adequate air supply.
3. Firewood of good quality and proper size.
4. Catalytic combustor in good condition.
5. Clean chimney, properly sized and installed.
6. Door gasket tight and firm.

Considering all of the above, number one is the most important for safe and efficient operation of any woodstove. Please study the operation instructions carefully. Consult your BLAZE KING dealer or call the Customer Service Department at Blaze King in the U.S.A. at 509-522-2730 or in Canada at 250-493-7444 if you have any questions not answered in this manual.

All of the six above mentioned needs are interrelated. A deficiency in any one will affect all of the others. If you encounter a problem, determine the source of the problem and then follow-up by checking the other needs as possible contributing factors.

PROBLEM: Chimney Fire	
CAUSE Act immediately regardless of cause	SOLUTION Turn the thermostat to lowest setting, check loading door to be sure it is tightly closed. Call Fire Department.
After the fire is out, have your chimney and flue connector inspected by a certified chimney sweep. A damaged masonry chimney should be repaired or rebuilt. A prefabricated chimney (factory built) that is damaged should be replaced. Any damage to the flue connector should be corrected before the system is used again.	
Possible causes of a chimney fire, and remedies for those causes, can be found further in this section: "Excessive Creosote Formation", and "Spots of Creosote Accumulation in Chimney or Flue Connector".	

PROBLEM: Not enough heat.	
CAUSE Green or wet wood. Not enough fuel in stove.	SOLUTION Use seasoned wood. Don't be afraid to FULLY load the stove. A FULL load of wood won't burn any hotter than the thermostat is set.
Obstruction in chimney or cap screen. Combustor plugged or coated.	Remove obstruction. See "COMBUSTOR, TESTING" See "COMBUSTOR, CLEANING"
Combustor not functioning.	See "COMBUSTOR, TESTING". If needed, replace combustor, See "COMBUSTOR, REPLACING".
Thermostat set too low.	Raise thermostat setting.
Thermostat not operating properly.	Consult your Blaze King dealer.
Poor draft caused by an oversize flue	Measure draft with Manometer. See "CHIMNEY DRAFTS" Consult your Blaze King dealer or a chimney sweep.
Strong, gusting winds causing downdraft in chimney	Install wind-resistant chimney cap. Directional caps may not stay freely rotating. If you have a directional cap, check it frequently.
Tightly sealed house, inadequate air supply.	Slightly open a window, near the stove or install an outside air kit.
Reloading too much wood on top of too few coals.	Allow a larger bed of coals to build up.

PROBLEM: Too much heat.	
CAUSE	SOLUTION
By-Pass door left open.	Close the by-pass door.
Thermostat set too high.	Lower thermostat setting.
Loading door gasket leaking, admitting excess air into firebox.	Replace door gasket and/or adjust door. See "GASKET INSPECTION"
Excessive draft in the chimney.	Measure draft with a Manometer. See "DRAFTS". Consult your Blaze King dealer or a chimney sweep. Install a cap.
Thermostat not operating properly.	Consult your Blaze King dealer.
Wood is too small.	Use larger pieces.

PROBLEM: One or both fans will not run, or there is no adjustment for fan speed.	
CAUSE	SOLUTION
Fans mounted improperly.	Check that fan blade's not touch edges of hole.
Fan speed control.	Consult your Blaze King dealer for replacement.

PROBLEM: Fans minimum speed too fast or maximum speed too slow.	
CAUSE	SOLUTION
Fan speed control out of adjustment.	Consult your Blaze King Dealer.

PROBLEM: Excessive creosote formation in chimney and chimney Connector.	
CAUSE	SOLUTION
By-pass door left open.	Close by-pass door.
By-pass door not sealing tightly.	Inspect by-pass door and seal for warping. Ash or creosote buildup may occur on door or seat. With stove cold scrape and vacuum area around by-pass. Be sure all mating steel surfaces are clean and smooth.
Improper operation.	Check thermostat setting and operating procedures. See "THERMOSTAT & OPTIMAL THERMOSTAT SETTING"
Wood too green or wet.	Use seasoned wood. Use a moisture meter to confirm.
Catalytic combustor not operating properly.	Inspect the combustor. See "CATALYTIC COMBUSTOR, TESTING"
Poor draft caused by an oversize or short flue, etc.	Measure draft with Manometer. See "DRAFTS". Consult your Blaze King dealer or a chimney sweep.
Chimney too cold or poorly insulated.	Upgrade chimney system. Consult your Blaze King dealer or a chimney sweep.

PROBLEM: Catalytic combustor thermometer (on top of stove) does not go into "Active" zone, or does not stay there for long. (Fans must be in "off" position for 10 minutes prior to checking)	
CAUSE	SOLUTION
Improper operation.	Check thermostat setting and operating procedures. See "THERMOSTAT & OPTIMAL THERMOSTAT SETTING"
Obstruction in chimney or cap.	Clean chimney, remove obstructions.
Faulty combustor thermometer.	Replace thermometer and Recheck combustor operating Temperature.
Wood too green or wet.	Use seasoned wood.

Combustor plugged or coated.	Clean combustor. See "CATALYTIC COMBUSTOR TESTING"
Combustor not functioning.	Check and test combustor. If needed replace combustor. See "CATALYTIC COMBUSTOR, REPLACING"
Thermostat not operating properly.	Consult your blaze King Dealer.
By-pass door leaking or not closing completely.	Inspect and clean area around by-pass doors. Adjust or replace gasket if necessary. Consult your Blaze King Dealer.

PROBLEM: Spots of creosote accumulation in chimney or chimney connector.

CAUSE	SOLUTION
Air leaks in chimney or chimney connector.	Inspect chimney and / or chimney connector. Repair or replace as necessary. Check to be sure that the chimney connector is installed correctly.

CAUTION: a leaking chimney connector is a fire hazard and demands immediate attention.

Poor draft caused by an oversize flue, single wall pipe, to many elbows, etc.	Measure draft with Manometer. See "DRAFTS". Consult your Blaze King dealer or a chimney sweep.
---	--

PROBLEM: Door glass quickly becomes coated with creosote.

CAUSE	SOLUTION
Low thermostat setting or lowering the thermostat setting too far, too quickly.	Turn the thermostat to the warmest setting during the first 20-30 minutes or until the fire is well established after each reloading.
Poor draft caused by an oversize or short flue, etc.	Measure draft with Manometer. See "DRAFTS". Consult your Blaze King dealer or a chimney sweep.
Obstruction in chimney or cap screen.	Remove obstruction. Clean chimney and/or cap screen.
Strong, gusting winds causing downdraft in chimney.	Install wind-resistant chimney cap.
Tightly sealed house, inadequate air supply.	Open a window, slightly, near the stove.
Burning poorly seasoned wet wood, or wood with high pitch content.	Use seasoned wood with low pitch content, such as some types of pine.

PROBLEM: The combustor temperature cannot be controlled. Turning the thermostat down often makes the combustor temperature go up.

CAUSE
Turning the thermostat down, particularly in the first half of the burn cycle, causes the fire to emit more smoke, which is fuel for the combustor. The combustor temperature therefore climbs for up to several hours. This is normal, and is of no concern. As long as only the combustor temperature is elevated, there is nothing to worry about.

PROBLEM: Smoke spills from door opening when loading fuel

CAUSE	SOLUTION
Spark arrestor screen on cap plugged.	Clean spark arrestor screen to bare metal wire.
Chimney too cold.	Make certain double wall stove pipe is used in installation.
Not enough vertical rise.	Make certain a minimum vertical rise of 36" is observed prior to elbows. Use two 45 elbows instead of 90 elbow.
Chimney not drafting.	Turn thermostat to highest setting, open bypass, leave loading door closed and wait 5-10 minutes to increase chimney or flue temperature.

Princess Classic PE1006BK

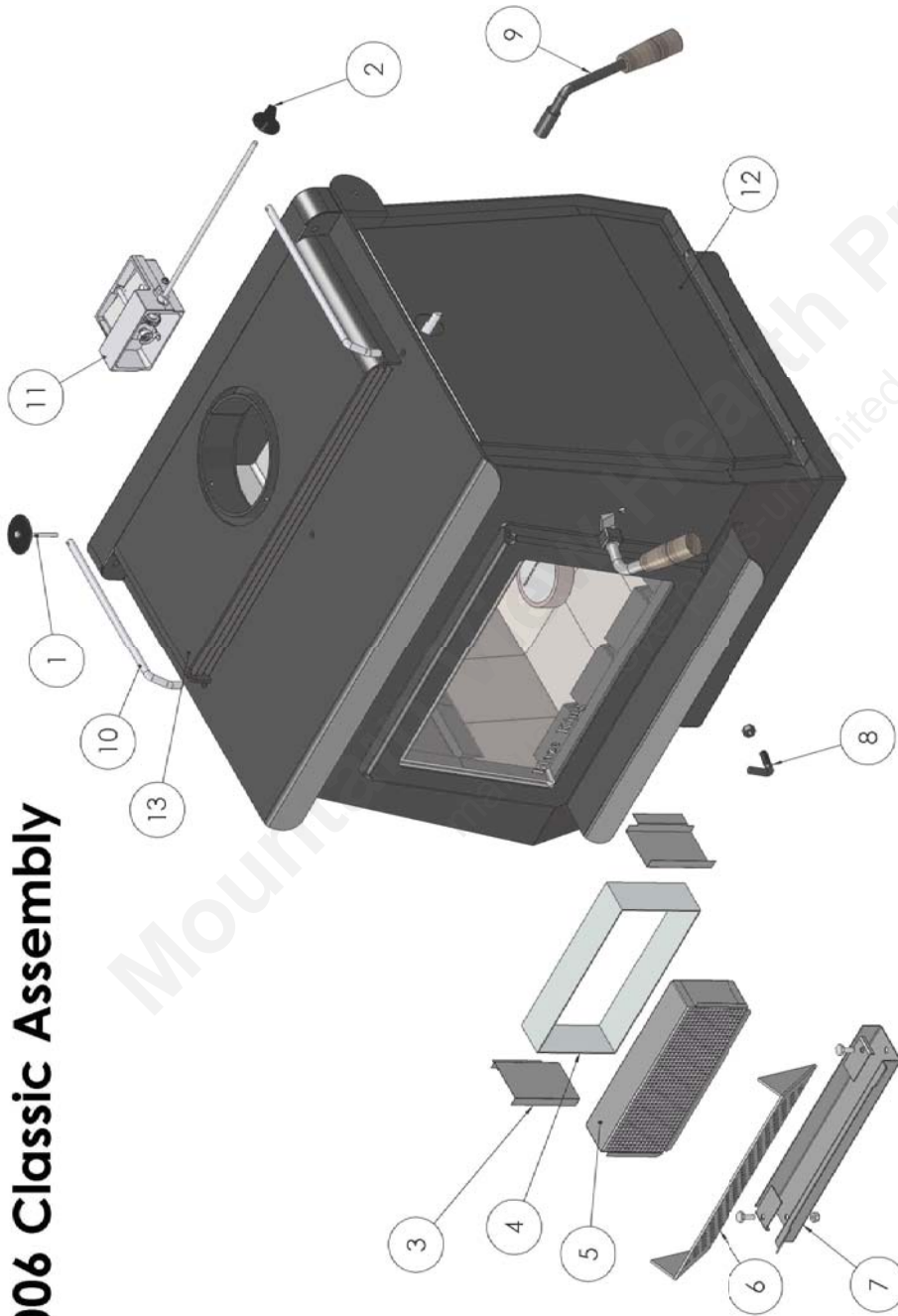

PE1006 Classic Assembly

ITEM NO.	PART NUMBER	DESCRIPTION	QTY.
1	0342C	2" Cat Thermometer w/ "Blaze King" Knob Black 1.5dx.75 high	1
2	0102	Bypass Retainer	1
3	4498	Comb Gasket Slit 2x1/16 by sq ft	2
4	0341C 3ft.	Combustor PE1006 (incl. gasket)	1
5	Z4400G	Flame Shield	1
6	Z4438BB	Dome Guard Kit	1
7	Z4551	Latch Catch Classic	1
8	5784EE	Bypass Handle	1
9	Z4467	Top Rail Assembly PE/KE	1
10	Z4460	Thermostat PE1006	1
11	Z3005C	Side shield Kit	1
12	S/SP1006	Convection Deck	1
13	Z1744		1

Princess Parlor PE1006LBK

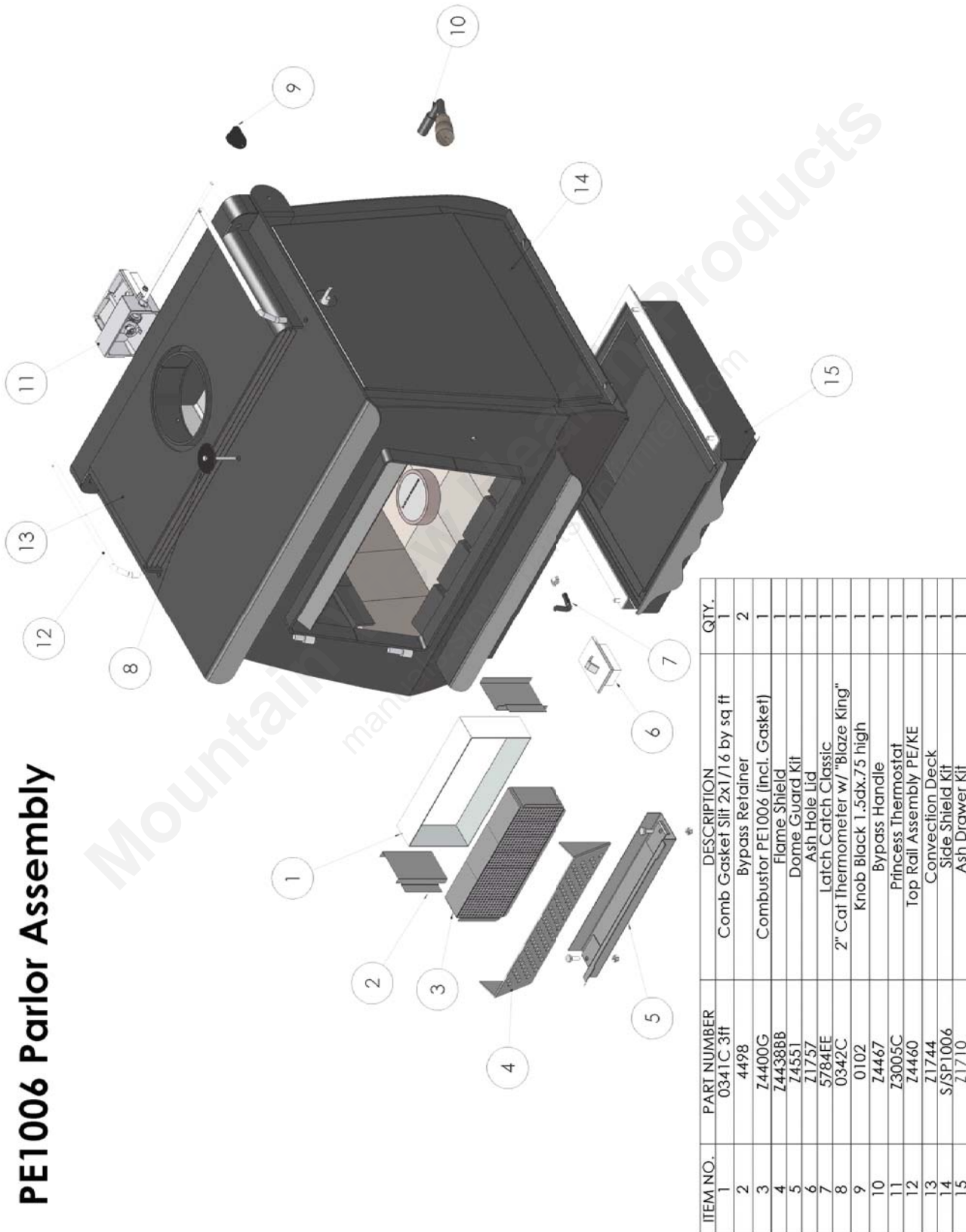

PE1006 Parlor Assembly

ITEM NO.	PART NUMBER	DESCRIPTION	QTY.
1	0341C 3ft	Comb Gasket Slit 2x1/16 by sq ft	1
2	4498	Bypass Retainer	2
3	Z4400G	Combustor PE1006 (incl. Gasket)	1
4	Z44388B	Flame Shield	1
5	Z4551	Dome Guard Kit	1
6	Z1757	Ash Hole Lid	1
7	5784EE	Latch Catch Classic	1
8	0342C	2" Cat Thermometer w/ "Blaze King"	1
9	0102	Knob Black 1.5dx.75 high	1
10	Z4467	Bypass Handle	1
11	Z3005C	Princess Thermostat	1
12	Z4460	Top Rail Assembly PE/KE	1
13	Z1744	Convection Deck	1
14	S/SP1006	Side Shield Kit	1
15	Z1710	Ash Drawer Kit	1

PE1006 Ultra Assembly

Princess Ultra PE1006UBK

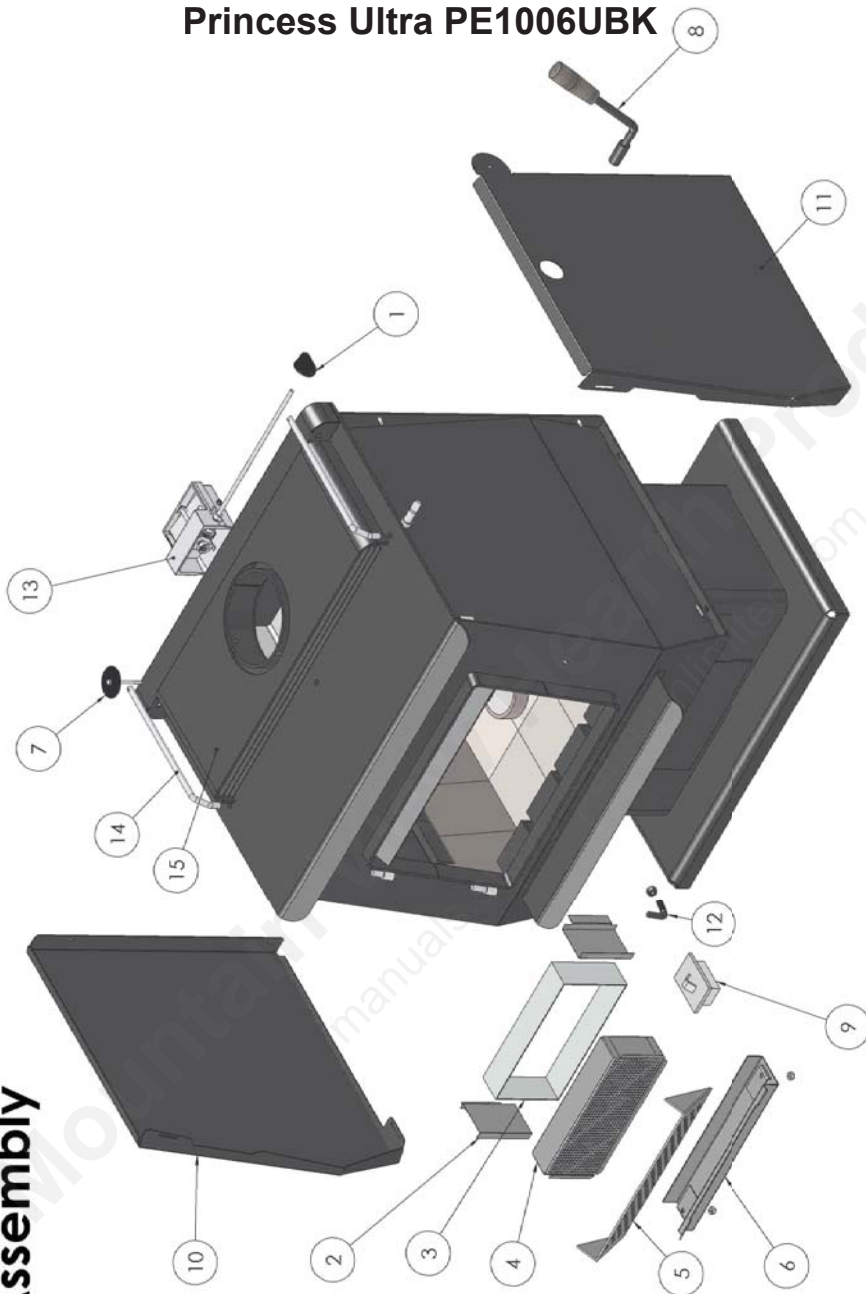

ITEM NO.	PART NUMBER	DESCRIPTION	QTY.
1	0102	Knob Black 1.5dx.75 high	1
2	4498	Bypass Retainer	2
3	0341C 3ft.	Comb Gasket Slit 2x1/16 by sq ft	1
4	Z4400G	Combustor PE1006	1
5	Z44388B	Flame Shield	1
6	Z4551	Dome Guard Kit	1
7	0342C	2" Cat Thermometer w/ "Blaze King"	1
8	Z4467	Bypass Handle	1
9	Z1757	Ash Hole Lid	1
10	4476L	Side Shield Ultra Left	1
11	4476R	Side Shield Ultra Right	1
12	5784EE	Latch Catch Classic	1
13	Z3005D	Princess Ultra Thermostat	1
14	Z4460	Top Rail Assembly PE/KE	1
15	Z1744	Convection Deck	1

PE1006 Door Assembly

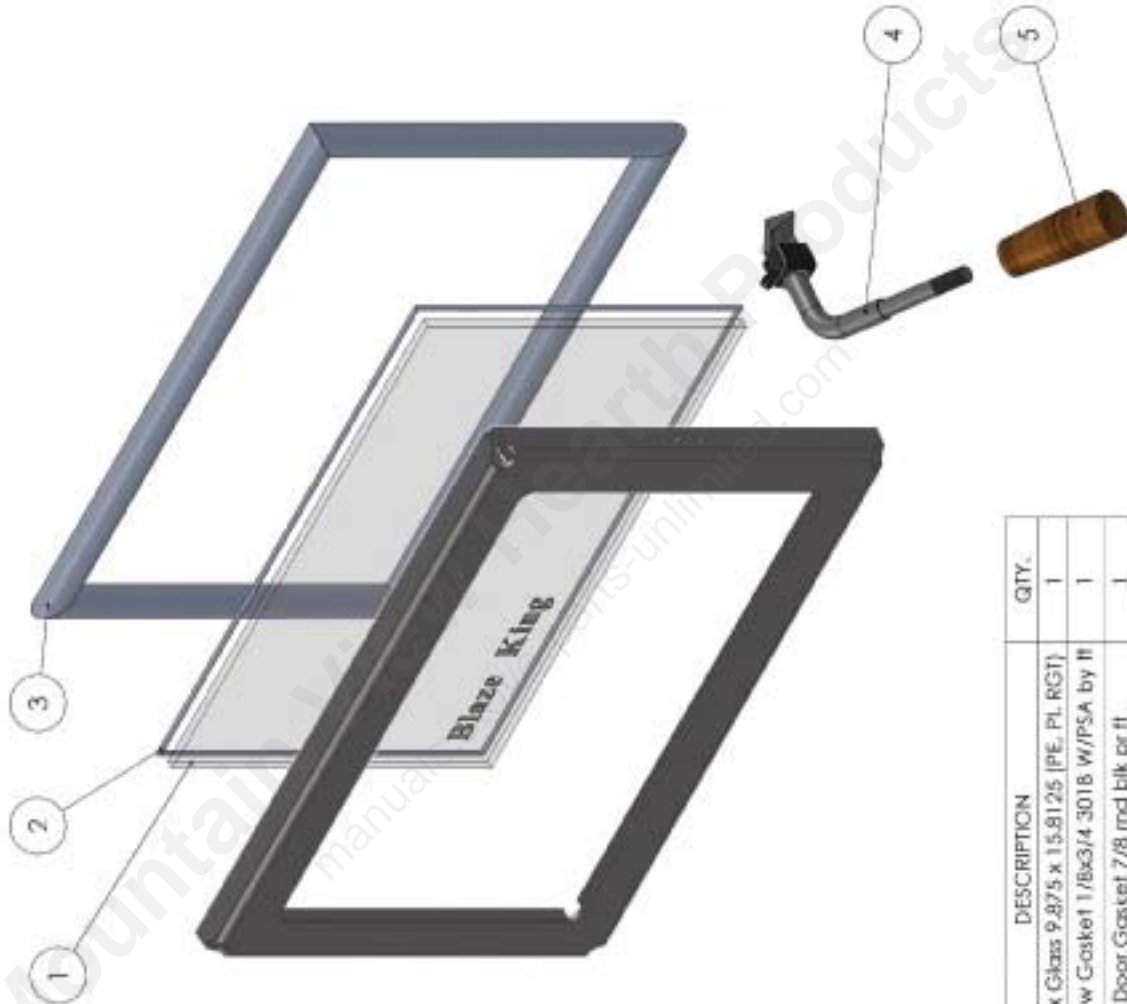

ITEM NO.	PART NUMBER	DESCRIPTION	QTY.
1	0246	Robax Glass 9.875 x 15.8125 (PE, PL, RGT)	1
2	0254A.S	Window Gasket 1/8x3/4 3018 W/PSA by Ifl	1
3	0185-6H	Door Gasket 7/8 md blk pr flt	1
4	Z5785	Handle Assembly (Int. latch)	1
5	0121A	Wood Handle 3 3/8 x 1 1/4	1

REPLACEMENT PARTS

Z1714 Fan Kit Assembly

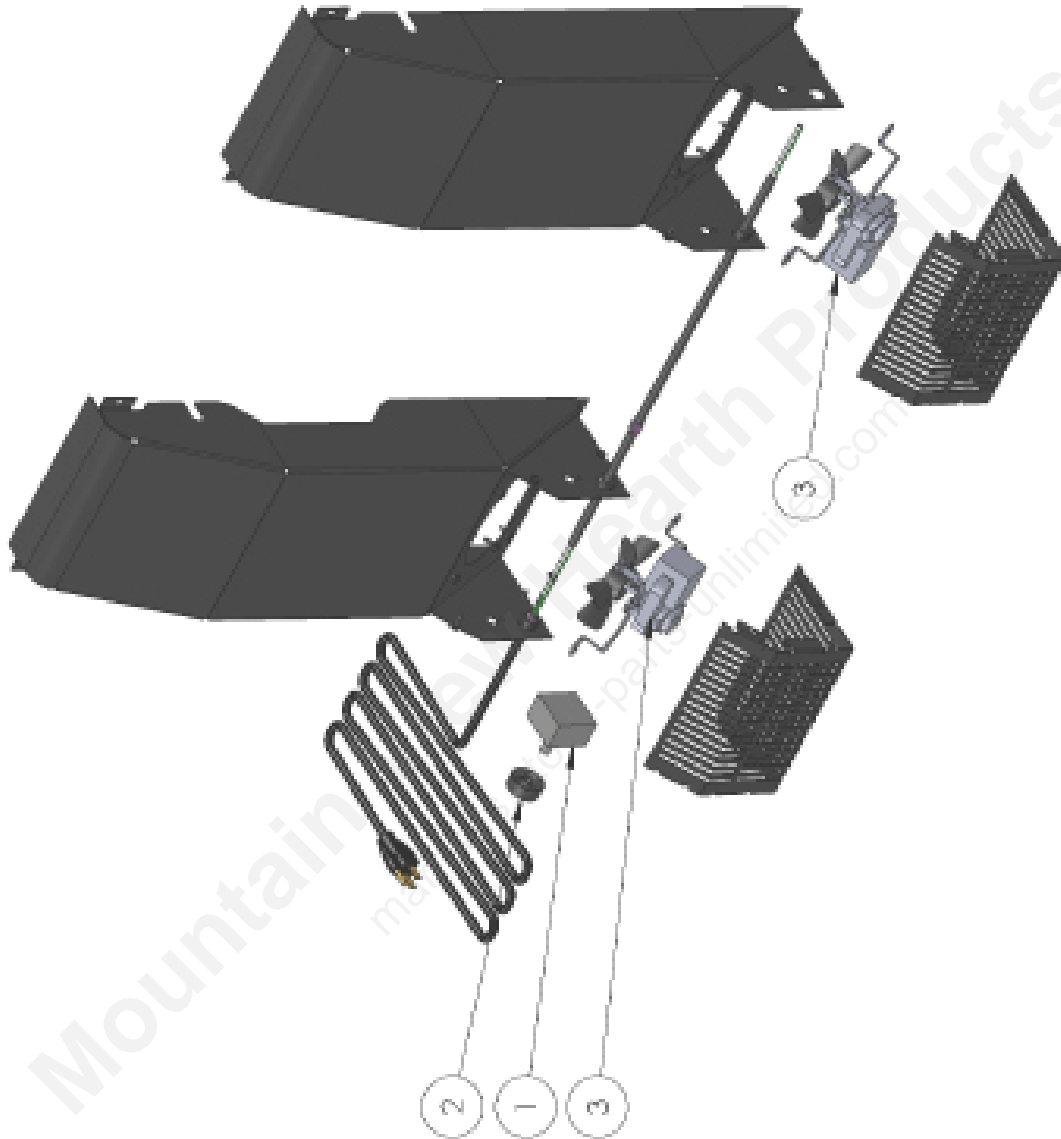

ITEM NO.	PART NUMBER	DESCRIPTION	QTY.
1	0136	Rheostat with Off Switch	1
2	0137	Rheostat Knob silver Inlay	1
3	0175C	Fan Axial Spider mint Muffin (Bay)	2

Princess Classic Brick Layout

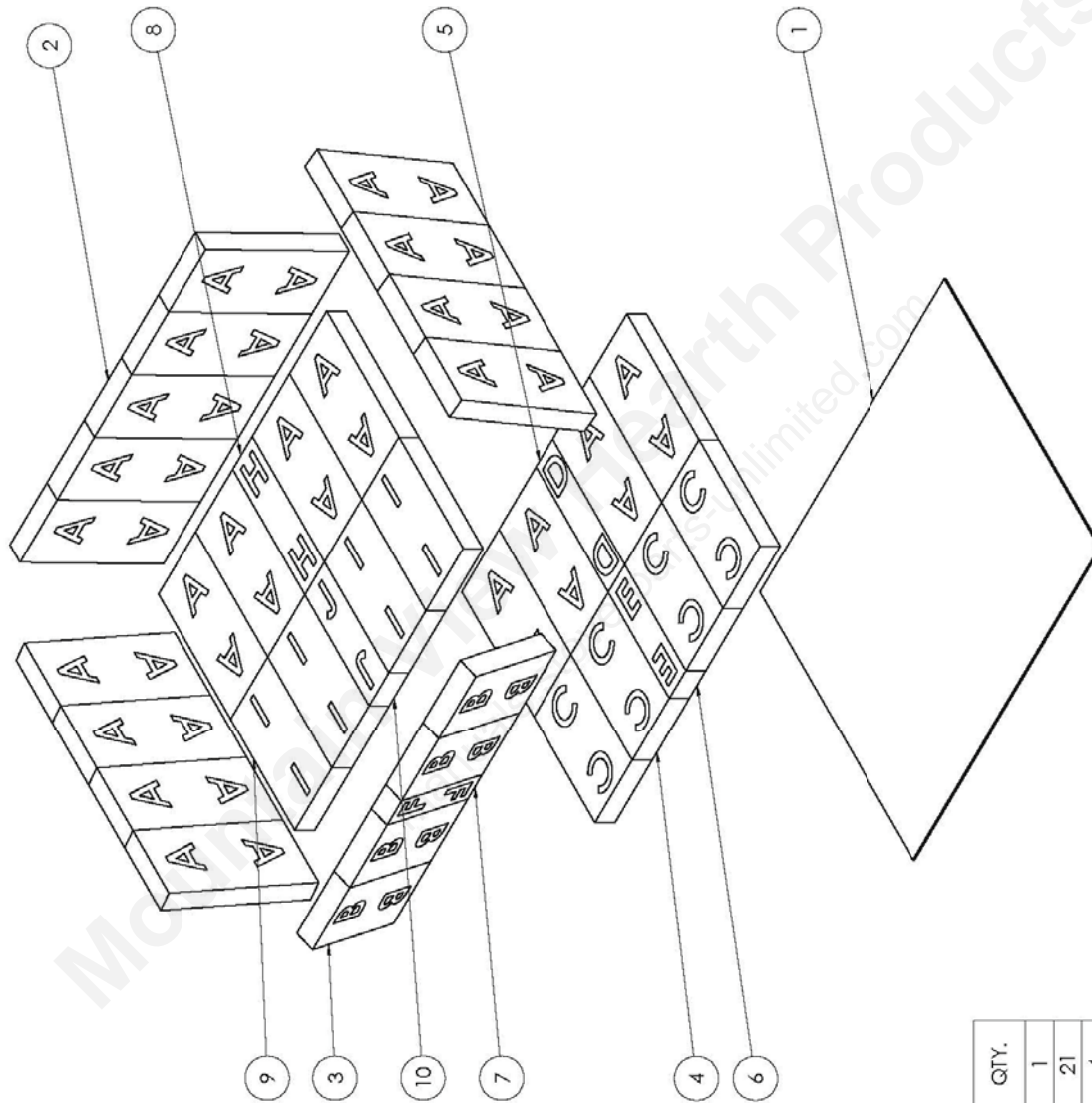

ITEM NO.	PART NUMBER	QTY.
1	0830D	1
2	A Size Brick	21
3	B Size Brick	4
4	C Size Brick	4
5	D Size Brick	1
6	E Size Brick	1
7	F Size Brick	1
8	H Size Brick	1
9	I Size Brick	4
10	J Size Brick	1

REPLACEMENT PARTS

Princess Parlor & Ultra Brick Layout

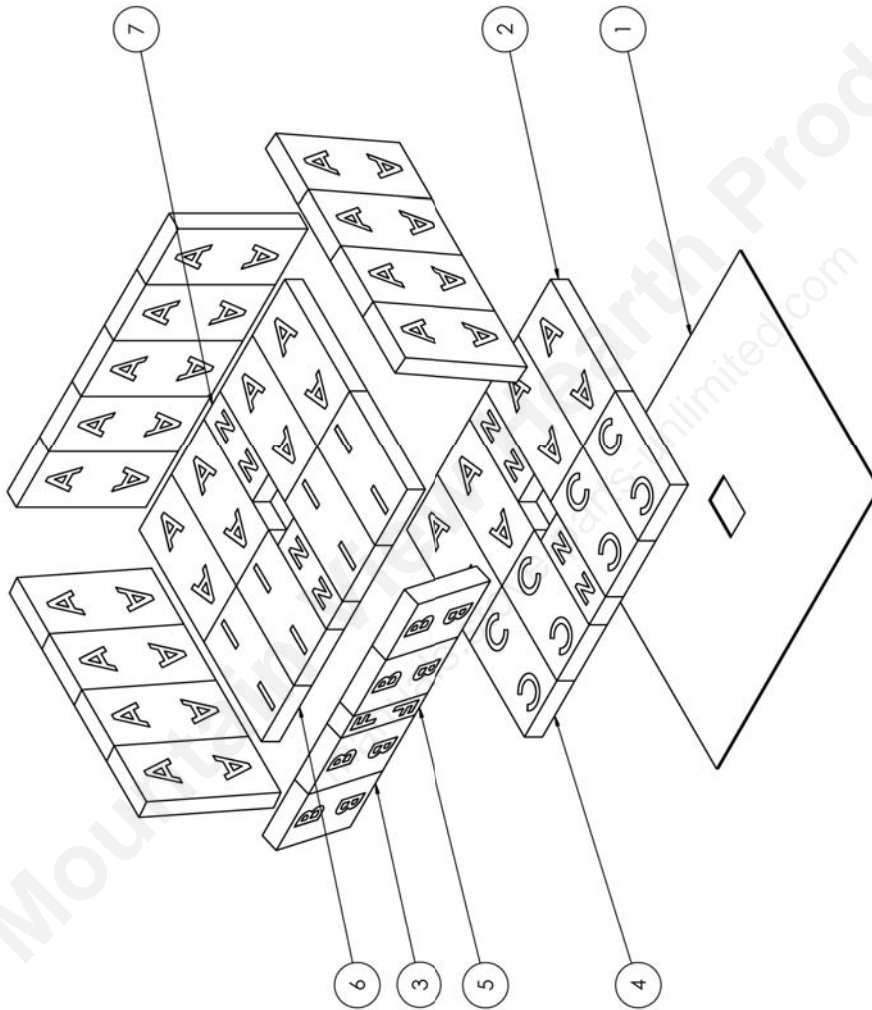

ITEM NO.	PART NUMBER	QTY.
1	0830C	1
2	A Size Brick	21
3	B Size Brick	4
4	C Size Brick	4
5	F Size Brick	1
6	I Size Brick	4
7	N Size Brick	4

BLAZE KING WOOD LIMITED WARRANTY

Blaze King and Valley Comfort’s respective brands extend the following warranty for wood fired appliances purchased from an authorized Blaze King / Valley Comfort dealer and installed in the United States of America or Canada. Warranty starts with date of purchase by the original owner (End User) except as noted for replacement parts.

Warranty Period		Components Covered	
Parts	Labor	Wood	
1 Year		X	All parts, materials and surface finishes (flaking and peeling) Subject to Conditions, Exclusion, and Limitations listed.
2 Years		X	Fan assemblies and motors, thermal sensors, catalytic thermometer, bi-metallic thermostat assembly, door handle metal components.
5 Years	2 Years	X	Firebox & Heat Exchanger, Bypass Door Steel Components
6 Years		X	Catalyst Combustor (see Conditions, Exclusions, and Limitations)
1 Year		X	Other Replacement Parts
See Conditions, Exclusions, and Limitations			

Blaze King Wood Limited 5 Year Warranty

Blaze King is the manufacturer of the Blaze King line of heating products. At Blaze King, our commitment to the highest level of quality and customer service is the most important thing we do. Each Blaze King stove is built on a tradition of using only the finest materials and is backed by our limited warranty to the original purchaser. With Blaze King, you're not just buying a stove; you're buying a company with years of unequalled performance and quality.

Limited Six (6) Year Warranty:

The CATALYTIC COMBUSTOR is under warranty by Blaze King for six (6) years from the date of original retail purchase. The purchaser shall pay the following share of the then current retail price for the combustor: The first three (3) years no charge, 4th year 60%; 5th year 70%, 6th year 80%. The Combustor must be returned to your dealer along with a completed COMBUSTOR FAILURE REPORT and original proof of purchase document.

Limited (5) Year Warranty:

Under this warranty, Blaze King covers the stove body and accessories against defects in materials and workmanship, for part repair or replacement for the first five (5) years *** to the original purchaser. This Warranty covers: All Steel firebox components against defects in material and workmanship. Please see the exclusions and limitation section below as certain restrictions and exclusions apply this warranty.

Limited Two (2) Year Warranty:

Under this warranty, Blaze King covers, fan assemblies, modular thermostat and door handle steel components against defects in materials and workmanship, for part repair or replacement and limited labor for the first two (2) years to the original purchaser. Please see the exclusions and limitation section below as certain restrictions and exclusions apply to this warranty.

Limited One (1) Year Warranty:

Under this warranty, Blaze King covers all parts and materials against defects in materials and workmanship including exterior paint finishes, for part repair or replacement and limited labor for the first year to the original purchaser. Please see the exclusions and limitation section below as certain restrictions and exclusions apply to this warranty.

How the Warranty Works

1. All warranties by the manufacturer are set herein and no claim shall be made against the manufacturer on any oral warranty or representation. All claims under this Limited Warranty must be made in writing by your dealer.
2. Any stove or part thereof that is repaired or replaced during the Limited Warranty period will be warranted under the terms of the Limited Warranty for a period not exceeding the remaining term of the original Limited Warranty or six (6) months, whichever is longer.
3. For any part or parts of this stove, which in our judgment show evidence of defects, Blaze King reserves the option to repair or to replace the defective part(s) through an accredited distributor or agent, provided the defective part is returned to the distributor or agent, transportation prepaid, if requested.
4. If you discover a problem that you think may be covered by the Limited Warranty, you **MUST REPORT** it to your Blaze King dealer **WITHIN 30 DAYS** from the date the problem was first detected, giving them proof of purchase and the date of purchase. The dealer will investigate the problem and work with Blaze King to determine whether the problem:
 - a) Is covered by the Limited Warranty or
 - b) Can be fixed in your home or does the product need to be returned to Blaze King for repair.
5. If Blaze King determines that the stove needs to be returned to Blaze King for repair, the customer has the responsibility and the expense of removing it from their home and shipping it to Blaze King. If the problem is covered by the Warranty, Blaze King will repair or replace the item at their discretion and the customer will be responsible for return shipping and re-installation in their home.
6. If the problem is not covered by the Limited Warranty, the customer will be responsible for all repair costs, as well as all storage, shipping and the cost of removing and re-installing the stove.

If you are not satisfied with the service provided by the Blaze King dealer, write to Blaze King at the address listed on the last page of the Owner's Manual. Include a copy of the original purchase invoice and a description of the problem.

Exclusions and Limitations:

1. This Warranty does not cover tarnish, discoloration or wear on the plated surfaces. Painted finishes will change color after initial firing and will continue to change through the lifetime of the stove. This is normal occurrence for all high temperature coatings.
2. This Warranty does not cover gasket material or firebrick.
3. Blaze King strongly recommends installation by a certified installer. Failure to comply may adversely affect coverage under the terms of this warranty. This Limited Warranty covers defects in materials and workmanship only if the product has been installed in accordance with local building and fire codes; in their absence refer to the owner's manual. If the product is damaged or broken as a result of any alteration, wilful abuse, mishandling, accident, neglect, or misuse of the product, the Limited Warranty does not apply.
4. The stove must be operated and maintained at all times in accordance with the instructions in the Owner's Manual. If the unit shows signs of neglect or misuse, it is not covered under the terms of this Warranty policy. Performance problems due to operator error will not be covered by the Limited Warranty policy. Some minor expansion, contraction, or movement of certain parts and resulting noise, is normal and not a defect and, therefore, is not covered under this Limited Warranty.
5. Misuse includes over-firing. Over-firing can be identified later by warped plates and paint pigment being burnt off. Over-firing this appliance can cause serious damage and will nullify the Limited Warranty.
6. The Limited Warranty will cover glass thermal breakage only and will not cover misuse of the stove glass, including but not limited to:
 - a) Glass that is struck, has surface contaminates or has had harsh or abrasive cleaners used on it.
 - b) If the door is slammed or is closed while wood in the firebox is protruding out the stove opening thus striking the glass.
7. This warranty does not cover products made or provided by other manufacturers and used in conjunction with the operation of this stove without prior authorization from Blaze King. The use of such products may nullify the Limited Warranty on this stove. If unsure as to the extent of this Limited Warranty, contact your authorized Blaze King dealer before installation.
8. Blaze King will not be responsible for inadequate performance caused by environmental conditions.
9. The Limited Warranty does not cover installation and operational related problems such as use of downdrafts or spillage caused by environmental conditions. Environmental conditions include but are not limited to nearby trees, buildings, roof tops, wind, hills, mountains, inadequate venting or ventilation, excessive offsets, negative air pressures or other influences caused by mechanical systems such as furnaces, fans, clothes dryers etc.
10. The Limited Warranty does not cover damage caused by burning salt-saturated wood, corrosive driftwood, chemically treated wood or any fuel not recommended in the Owner's Manual (use cord wood only).
11. The Limited Warranty is void if:
 - a) The stove has been operated in atmospheres contaminated by chlorine, fluorine or other damaging chemicals.
 - b) The stove is subject to submersion in water or prolonged periods of dampness or condensation.
 - c) Any damage to the unit, combustion chamber or other components due to water, or weather damage which is the result of, but not limited to, improper chimney/venting installation.
 - d) Salt air in coastal areas or high humidity can be corrosive to the finish; these environmental conditions can cause rusting. Damage caused by salt air or high humidity is not covered by the Limited Warranty.
12. Exclusions to the Limited Warranty include: injury, loss of use, damage, failure to function due to accident, negligence, misuse, improper installation, alteration or adjustment of the manufacturer's settings of components, lack of proper and regular maintenance, alteration, or act of God.
13. The Limited Warranty does not cover damage caused to the stove while in transit. If this occurs, do not operate the stove and contact your courier and/or dealer.
14. The Limited Warranty does not extend to or include paint, door or glass gaskets or firebricks damage caused by normal wear and tear, such as paint discoloration or chipping, worn or torn gaskets, chipped or cracked firebrick, etc.
15. The Limited Warranty does not include damage to the unit caused by abuse, improper installation, or modification of the unit.
16. Damage to plated surfaces caused by fingerprints, scratches, melted items, or other external scores and residues left on the plated surfaces from the use of abrasive cleaners or polishes is not covered in this warranty.

17. Blaze King is free of liability for any damages caused by the stove, as well as inconvenience expenses and materials. The Limited Warranty does not cover incidental or consequential damages.
18. The Limited Warranty does not cover any loss or damage incurred by the use or removal of any component or apparatus to or from the Blaze King stove without the express written permission of Blaze King and bearing a Blaze King label of approval.
19. Any statement or representation of Blaze King Products and their performance contained in Blaze King advertising, packaging literature, or printed material is not part of the Limited Warranty.
20. The Limited Warranty is automatically voided if the stove's serial number has been removed or altered in any way. If the stove is used for commercial purposes, it is excluded from the Limited Warranty.
21. No dealer, distributor, or similar person has the authority to represent or warrant Blaze King Products beyond the terms contained within the Limited Warranty. Blaze King assumes no liability for such warranties or representations.
22. Blaze King will not cover the cost of the removal or re-installation of the stove, hearth, facing, mantels, venting or other components.
23. Labor to replace or repair items under this Limited Warranty will be covered per our warranty service fee reimbursement and labor rates are set per component schedule. Labor rates vary from location to location and as such total labor costs may not be covered. Please consult with your dealer or service technician for any additional charges such as travel time or additional labor charges that may apply.
24. For parts of the Blaze King woodstove or fireplace insert warranted beyond the first year, the five year limited warranty will have the same obligations as described in this document, provided, however that the purchaser shall pay the following percentage of the then current retail cost of the repair or the replacement, according to the year after purchase in the which the defect is brought to the attention of Blaze King.*** During the 2nd year----purchaser pays 20%. 3rd year ----purchaser pays 40%. 4th year -----purchaser pays 60%. 5th year---- purchaser pays 80%.
25. If a defect or problem is determined by Blaze King to be non warrantable, Blaze King is not liable for travel costs for service work. In the event of in-home repair work, the customer will pay any in-home travel fees or service charges required by the Authorized Dealer.
26. At no time will Blaze King be liable for any consequential damages which exceed the purchase price of the unit. Blaze King has no obligation to enhance or modify any stove once manufactured (example: as a stove model evolves, field modifications or upgrades will not be performed).
27. This Limited Warranty is applicable only to the original purchaser and it is nontransferable.
28. This warranty only covers Blaze King Products that are purchased through an authorized Blaze King dealer.
29. If for any reason any section of the Limited Warranty is declared invalid, the balance of the warranty remains in effect and all other clauses shall remain in effect.
30. The Limited Warranty is the only warranty supplied by Blaze King, the manufacturer of the stove. All other warranties, whether express or implied, are hereby expressly disclaimed and the purchaser's recourse is expressly limited to the Limited Warranty.
31. Blaze King and its employees or representatives will not assume any liability for damages, either directly or indirectly, caused by improper usage, operation, installation, servicing or maintenance of this stove.
32. Blaze King reserves the right to make changes without notice. Please complete and mail the warranty registration card and have the installer fill in the installation data sheet in the back of the manual for warranty and future reference.
33. Blaze King is responsible for stocking parts for a maximum of seven (7) years after discontinuing the manufacture or incorporation of the item into its products. An exception to this would be if an OEM supplier is not able to supply a part.

