

MODEL 18 NON-CATALYTIC UNIT

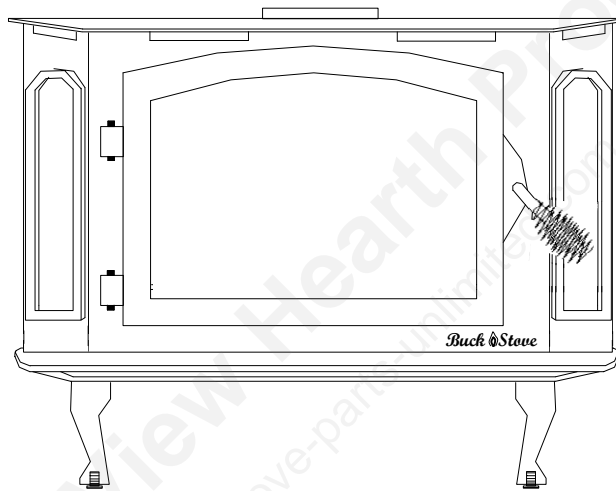

	FEATURES	
PREPARATIONS		INSTALLATION
OPERATION	MAINTENANCE	SAFETY

SAFETY NOTICE



IF THIS HEATER IS NOT PROPERLY INSTALLED, A HOUSE FIRE MAY RESULT. FOR YOUR SAFETY, FOLLOW THE INSTALLATION INSTRUCTIONS. CONTACT THE AUTHORITY HAVING JURISDICTION (SUCH AS MUNICIPAL BUILDING DEPARTMENT, FIRE DEPARTMENT, FIRE PREVENTION BUREAU, etc.) CONSULT BEFORE INSTALLATION TO DETERMINE THE NEED TO OBTAIN A PERMIT. KEEP THESE INSTRUCTIONS FOR FUTURE USE.

TESTED AND LISTED BY:



ITS/WARNOCK HERSEY, MIDDLETON, WI

**MANUFACTURED BY NEW BUCK CORPORATION
200 ETHAN ALLEN DRIVE, PO BOX 69
SPRUCE PINE, N.C. 28777**

www.buckstove.com

Revised: February 2013

Mountain View Hearth Products
manuals.stove-parts-unlimited.com

TABLE OF CONTENTS

Important Instructions	3
SECTION I: Introduction	4
SECTION II: Masonry Insert Installation.....	5
Installation Preparation-Fireplace	7
Mounting Trim Panels	9
SECTION III: Pre-Fab Insert Installation.....	12
SECTION IV: Residential Freestanding Installation.....	14
Residential Freestanding Installation Clearances	16
Alcove Installation Clearances	22
SECTION V: Freestanding Mobile Home Installation.....	24
Residential Freestanding And Mobile Home Installation Clearances Using Single Wall Pipe And Low Clearance Shields	25
Installation of Close Clearance Shields	26
Out Side Air Installation	28
SECTION VI: Wood Heater Safety.....	32
SECTION VII: Heater Operation	33
SECTION VIII: Operation For Room Air Blower/Maintenance	34
Maintenance	36
SECTION IX: Troubleshooting.....	37
Parts List	39
Warranty	40

EPA COMPLIANCE STATUS

The Model 18 heater meets the U.S. Environmental Protection Agency's Emission limits for wood heaters sold after July 1, 1992. Under specific conditions this heater has been shown to deliver heat at rates ranging from approximately 10,000 to 22,400 BTU/Hr for the Model 18.

MODEL 18 WOOD STOVE

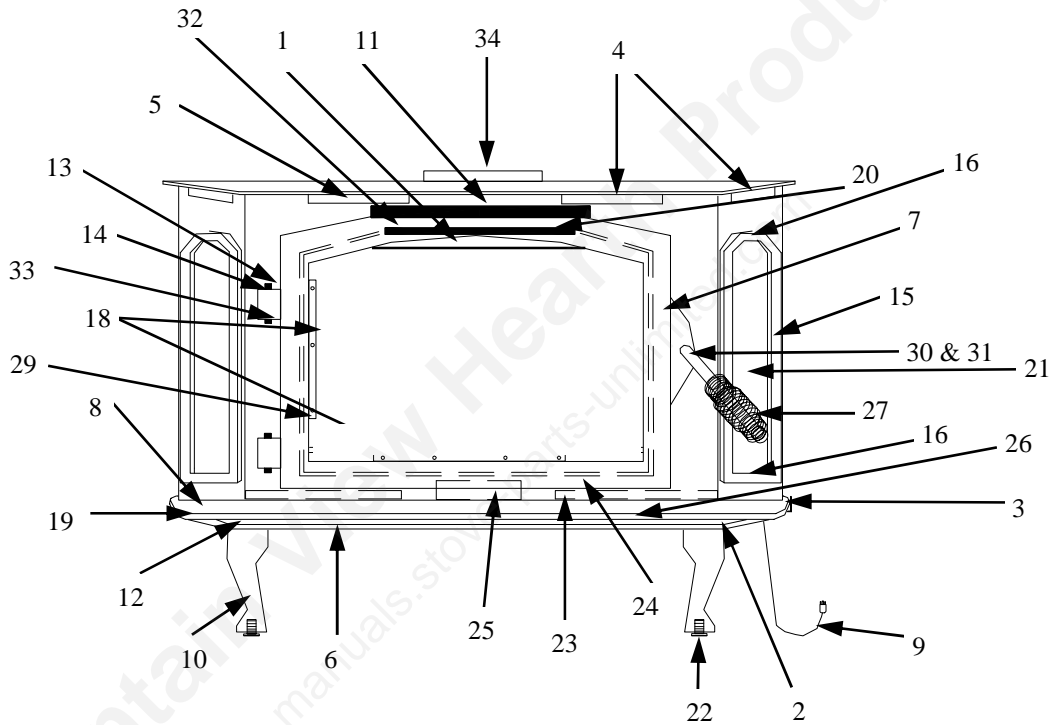

- | | | |
|--------------------------------|-----------------------------------|---------------------------------------|
| 1. Secondary air tubes | 16. Brass overlay mounting screws | 26. Disc thermostat |
| 2. Blower Air Chamber | 17. Door glass & logo | 27. Door handle & brass spring handle |
| 3. Primary air control | 18. Glass clips | 28. Air wash screen |
| 4. Warm air outlets | 19. Hearth Brass | 29. Glass gasket |
| 5. Baffles (interior of stove) | 20. Door Gasket | 30. Door latch |
| 6. Air inlet | 21. Side glass | 31. Door latch screw |
| 7. Door | 22. Leveling screws | 32. Blanket |
| 8. Hearth extension | 23. Firebrick | 33. Hinge pins |
| 9. Power cord | 24. Motor | 34. 6" Flue exit |
| 10. Legs | 25. Shot gun air box | |
| 11. Stainless steel plate | | |
| 12. Secondary Air Channel | | |
| 13. Brass cap | | |
| 14. Hinge Block | | |
| 15. Brass overlays | | |

INSTALLATION, OPERATION, AND MAINTENANCE INSTRUCTIONS MODEL 18

**BEFORE INSTALLING YOUR NEW BUCK STOVE,
READ THE ENTIRE INSTRUCTION MANUAL**

IMPORTANT INSTRUCTIONS

WARNING

THESE UNITS GENERATE A LOT OF HEAT, SO TREAT THEM WITH CARE. **HOT WHILE IN OPERATION!** KEEP CHILDREN, CLOTHING AND FURNITURE AWAY. CONTACT MAY CAUSE SKIN BURNS. “DO NOT USE CHEMICALS OR FLUIDS TO START THE FIRE.” “DO NOT BURN GARBAGE OR FLAMMABLE FLUIDS.” “DO NOT CONNECT TO ANY DISTRIBUTION DUCT OR SYSTEM.” READ ALL INSTRUCTIONS BEFORE INSTALLING AND USING APPLIANCE. FAILURE TO FOLLOW INSTRUCTIONS MAY RESULT IN PROPERTY DAMAGE, BODILY INJURY, OR EVEN DEATH. SAVE THESE INSTRUCTIONS FOR FUTURE REFERENCES.

- The New Buck Corp. non-catalytic Model 18 has been tested by ITS, Warnock Hersey to ANSI/UL Standards 1482.
- Install and operate your unit according to instructions provided in this manual. Local building codes may apply; therefore, contact your local building inspector or fire marshal for necessary installation requirements and permits which may go beyond these instructions. Contact your insurance company for coverage and installation inspection.
- **If MODEL 18 is installed in a mobile home:
“DO NOT INSTALL IN SLEEPING ROOMS.”**
- **NOTE: When burning any unit or appliance that combusts fuel for heat, such as coal, oil, wood or natural and (L.P.) liquid petroleum gas. We highly recommend the use of smoke and carbon monoxide detectors in your home.**
- Examine masonry fireplace and chimney prior to installation of fireplace accessory to determine that construction meets minimum fireplace construction requirements illustrated in instructions, that it is free from cracks, loose mortar, creosote deposits and other blockage or other signs of deterioration.

CAUTION

DO NOT USE MORE THAN ONE STOVE TO A CHIMNEY. DO NOT USE A FLUE INTENDED FOR A GAS APPLIANCE. DO NOT CONNECT THIS UNIT TO A CHIMNEY FLUE SERVING ANOTHER APPLIANCE. DO NOT CONNECT TO ANY AIR DISTRIBUTION DUCT OR SYSTEM.

- A factory-built pre-fabricated chimney may be used for your units when installed in compliance with the manufacturer's specification and uniform building code.

CAUTION

YOUR CHIMNEY MUST BE CORRECTLY SIZED. A CHIMNEY THAT IS TOO SMALL OR LARGE IN DIAMETER, OR TOO SHORT, CAN CAUSE YOUR STOVE TO SPILL SMOKE WHEN THE DOOR IS OPENED.

SECTION I

INTRODUCTION

Your Buck Stove is a non-catalytic unit designed to meet most stringent emissions standards without use of a catalytic combustor. This effect is achieved through use of a secondary air which is mixed with primary air in unit's firebox.

For peak performance, we suggest use of natural seasoned hard wood, loading wood length way from front to rear.

NOTE: Soft woods such as pine, create more creosote, clogging of chimney and produce a less efficient burn performance.

You should not burn trash or garbage, artificial or paper logs, gift wrapping, treated or painted wood or any type of coal or flammable fluids.

The primary air, which is controlled by user, burns the wood. Secondary air is admitted into firebox through secondary air tubes at top of the firebox. This secondary air burns impurities in smoke released from initial wood burning. The temperature necessary for this combustion is maintained through firebrick refractory. If any more technical information is necessary contact your local dealer.

This heater is equipped with a standard room air blower. For operation and uses of these electrical assemblies, see instructions provided in this manual on page 35.

SECTION II

MASONRY INSERT INSTALLATION

The Model 18 may be installed using an all masonry fireplace built in accordance with Uniform Building Code and National Fire Protection Association (NFPA). The first step in this type of installation is to determine acceptability of fireplace and chimney for use with a woodstove. Both construction and condition of fireplace are important considerations when installing a woodstove. The chimney should extend at least 3' above roof and at least 2' above any point of roof within 10'.

CAUTION

REMEMBER TO HAVE YOUR CHIMNEY INSPECTED FOR LEAKS AND BLOCKAGE **BEFORE** YOU INSTALL YOUR STOVE. "DO NOT CONNECT THIS UNIT TO A CHIMNEY FLUE SERVING ANOTHER APPLIANCE."

MINIMUM CLEARANCE MASONRY INSERT

MODEL 18

A. Side Wall Combustible	10"
B. Front Floor Protector	16"
C. Side Floor Protector	8"
D. Side Wood Trim	9"
E. Top Wood Trim	14"
F. Mantel or Brackets	21"

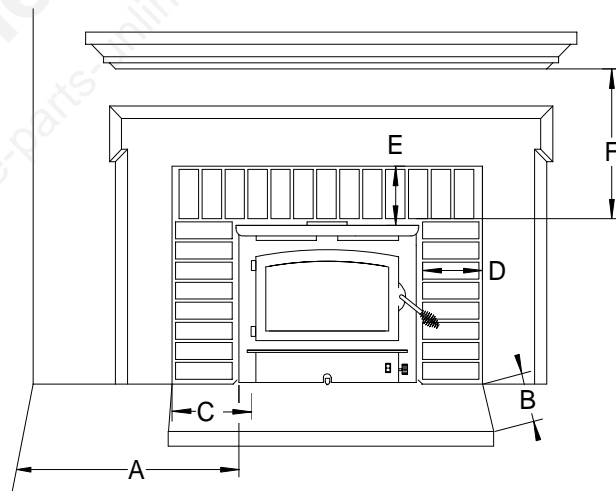

1. The hearth must be of masonry construction and must extend a minimum of 16" in front of firebox opening and a minimum of 8" to either side of firebox opening.
2. If there is not minimum hearth protection from front of firebox opening and front of masonry hearth, a floor protector must be used in front of hearth to protect combustible materials. The floor protector must be 3/8" minimum thickness non-combustible material or equivalent.(See Page 6).

FLOOR PROTECTION

Floor protection must be 3/8" minimum thickness non-combustible material or equivalent.

How to use alternate materials and how to calculate equivalent thickness

An easy means of determining if a proposed alternate floor protector meets requirements listed in the appliance manual is to follow this procedure:

1. Convert specification to R-value:
 - R-value is given—no conversion is needed.
 - K-factor is given with a required thickness (T) in inches:
C-factor is given: $R=1/C$
2. Determine the R-value of the proposed alternate floor protector.
 - Use the formula in step (1) to convert values not expressed as "R"
 - For multiple layers, add R-values of each layer to determine the overall R-value.
3. If the overall R-value of the system is greater than the R-value of the specified floor protector, the alternate is acceptable.

Example:

The specified floor protector should be 3/4" thick material with a K-factor of 0.84.

The proposed alternate is 4" brick with a C-factor of 1.25 over 1/8" mineral board with a K-factor of 0.29.

Step (a): Use formula above to convert specification to R-value. $R = 1/K \times T = 1/0.84 \times .75 = 0.893$

Step (b): Calculate R of proposed system. 4" brick of $C=1.25$, therefore $R_{brick} = 1/C = 1/1.25 = 0.80$ 1/8" mineral board of $K = 0.29$, therefore $R_{min.bd.} = 1/0.29 \times 0.125 = 0.431$

Step (c): Compare proposed system R of 1.231 to specified R of 0.893. Since proposed system R is greater than required, the system is acceptable.

Definitions:

$$\text{Thermal conductance} = C = \frac{\text{Btu}}{(\text{hr})(\text{ft}^2)(\text{°F})} = \frac{\text{W}}{(\text{m}^2)(\text{°K})}$$

$$\text{Thermal conductance} = K = \frac{(\text{Btu})(\text{inch})}{(\text{hr})(\text{ft}^2)(\text{°f})} = \frac{\text{W}}{(\text{m})(\text{°K})} = \frac{(\text{Btu})}{(\text{hr})(\text{tf})(\text{°F})}$$

$$\text{Thermal conductance} = R = \frac{(\text{ft}^2)(\text{hr})(\text{°F})}{\text{Btu}} = \frac{(\text{m}^2)(\text{°K})}{\text{W}}$$

Install in accordance with 24 CFR, Part 3280 (HUD).

POSSIBLE TOOLS NEEDED FOR INSTALLATION

If you decide to install your own stove, there are several hand tools you may need to do job. If you do not already have them, they are readily available at most hardware stores.

Caulking gun

Large adjustable wrench (may not be needed)

Drop cloths or newspapers

Vacuum cleaner or whisk broom

Flashlight

1 tube of RTV silicone, Code 103 or 106, or high temperature rubber cement rated between 450° F- 600° F

7/32" drill bit and drill

Socket/Ratchet Set

INSTALLATION PREPARATION-FIREPLACE

Fireplace:

1. Locate furniture and other materials away from front of fireplace to allow free access to fireplace.
2. Cover hearth and adjacent floor areas with a drop cloths to protect from soiling or marring surface.
3. Remove existing fireplace damper plate.
4. Thoroughly clean fireplace of ashes and soot.
5. Check chimney and smoke chamber for excessive buildup of creosote or soot. Also, check for obstructions, such as bird's nests. If chimney is excessively dirty, clean it or have someone clean it professionally BEFORE installing or using the room heater.
6. If fireplace has an ash dump or outside air provision, these must be sealed off with metal or tightly packed non-combustible insulation to prevent cold air from entering fireplace chamber.

MASONRY INSERT INSTALLATION OPTIONS

This unit (appliance) may be installed into an all masonry fireplace, built in accordance with Uniform Building Code and National Fire Protection Association (*NFPA 211*).

NOTE: *Check with local building officials for any permits required for installation of this unit and notify your insurance company before proceeding with installation*

In some cases such as improperly drawing fireplaces , oversize flue liners or to meet codes in certain areas it is recommended that one of the flowing procedures be followed:

- A. A **Chimney Connector** be installed from appliance flue exit through damper and a air-tight face seal. See option (A) page 8.
- B. A listed **Direct Connect** be installed from appliance flue exit through damper into first section of flue liner with air-tight seal. See option (B) page 8.
- C. A **Positive Connect** be installed from appliance flue exit continuing up through entire chimney and exiting at top of the chimney. See option (C) page 8.

NOTE: C. must be used with model 18 when installed into prefab fire place



SAFETY NOTICE

If this appliance is not properly installed, a house fire may result. For your safety, follow installation directions. Contact local building or fire officials about restrictions and installation inspection requirements in your area.

OPTION (A)

SEAL TRIM PANELS AND UNDER FRONT OF STOVE UNIT WITH INSULATION OR HIGH TEMPERATURE CAULK

STARTER PIPE

AIRTIGHT INSULATED CLEAN-OUT

REMOVE DAMPER OR WIRE IT OPEN

NOTE: New Buck Corporation grants no warranty, implied or stated, for the installation or maintenance of your appliance, and assumes no responsibility of any consequential damage (s).

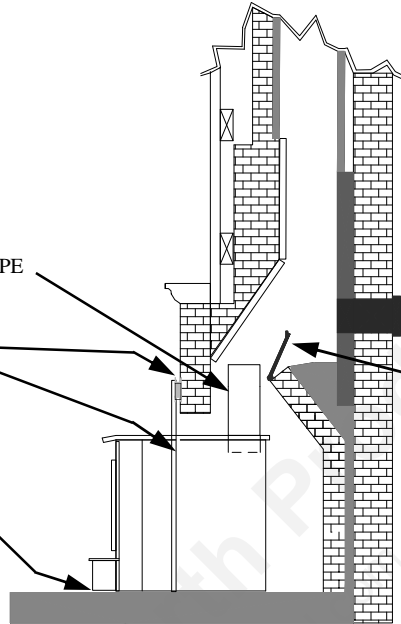

OPTION (B)

NOTE: Follow installation instruction with Direct Connection Kit. (Kit sold separately)

SEAL TRIM PANELS WITH INSULATION OR HIGH TEMPERATURE CAULK

STAINLESS STEEL CHIMNEY CONNECTOR MUST EXTEND 1' PAST THE BLOCK-OFF PLATE OR TO THE FLUE LINER

AIRTIGHT INSULATED CLEAN-OUT

REMOVE DAMPER OR WIRE IT OPEN

BLOCK-OFF PLATE OR DAMPER ADAPTER

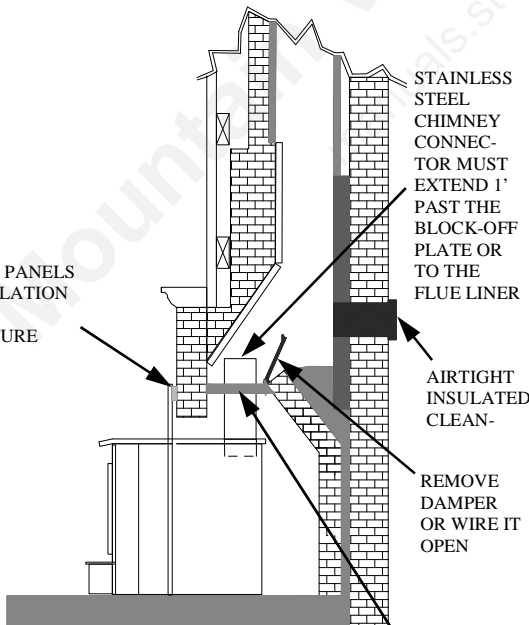

OPTION (C)

NOTE: Follow installation instruction with Positive Connection Kit. (Kit sold separately)

INSTALL A NON-COMBUSTIBLE COVER PLATE TO PREVENT WATER FROM ENTERING THE CHIMNEY

CAP (PREVENTS WATER FROM ENTERING)

FLUE LINER

THE LINER MUST BE STAINLESS STEEL CONNECTOR OR FLEXIBLE VENT. FOLLOW THE LINER MANUFACTURE'S INSTRUCTIONS FOR INSTALLATION AND SUPPORT

AIRTIGHT INSULATED CLEAN-OUT

TRIM PANELS

REMOVE DAMPER OR WIRE IT OPEN

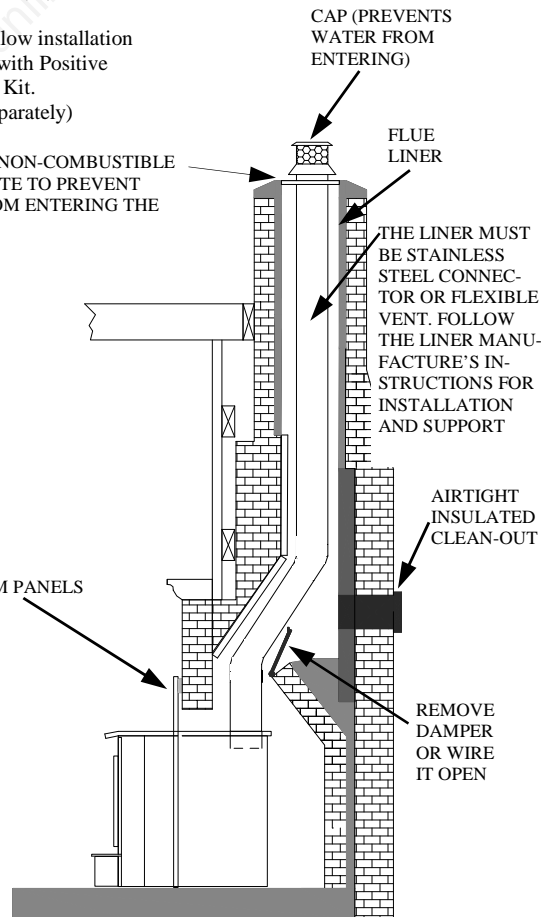

INSTALLATION PROCEDURE

(Use a chimney connector or a Listed Direct or Positive Connect) (See Page 8.)

POSITIONING HEATER

When positioning heater, following conditions **MUST** be met!
(See Figure 2).

1. The front of damper opening must be positioned **BEHIND** rear edge of the lintel to ensure proper draft. (See Figure 2).
2. Center heater in fireplace opening.

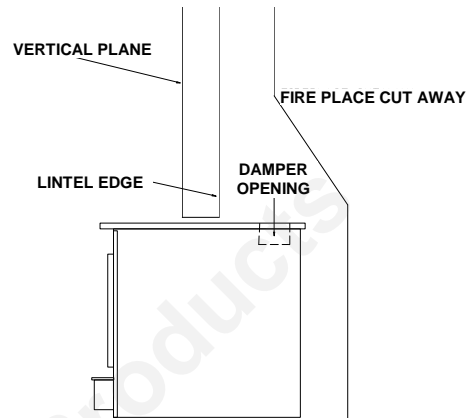

FIGURE 2 POSITIONING

MOUNTING TRIM PANELS

After unit is positioned, mark mounting position of trim panels as follows:

1. Place side trim panels flat against face of fireplace. Mark front edge of trim panel with a pencil to make a vertical reference line. (See Figure 3).
 2. Place top (long) trim panel on top of unit. The panel should be flat against the outside face of fireplace, and standing vertically. Mark along lower edge of trim panel with a pencil to make a reference line for mounting.
 3. Slide unit out of the fireplace far enough to work behind trim panel reference lines.
 4. Mount side trim panels. (See Figure 3).
 - a. Position side trim panel on reference line.
 - b. Drill mounting holes in center of side trim panel mounting brackets to allow for adjustment in and out if necessary.
 - c. Mount trim panel using self-tapping screws provided.
 5. Place top trim panel on reference mark. Top trim panel mounting bracket (supplied) must overlap rear lip of top trim panel. Drill mounting holes in top of stove using holes in bracket as guide. Tighten screws.
 6. Follow installation procedures in listed direct connect or positive connect kit you are using and install heater and connect kit in fireplace. If not using one of installation methods shown on Page 8, continue.
 7. Slide unit back into fireplace. Check to be sure that trim panels are properly positioned and lie flat against front of fireplace. If one or more of panels is out of position, slide unit out and reset by loosening the mounting screws and repositioning in slot.
 8. Reinstall top trim panel by sliding rear lip of top trim panel underneath front lip of mounting bracket already secured to top of unit.
- NOTE:** Mount top trim panel so that it sits in front of top of side trim panels.
9. Obtain brass trim kit provided with insert kit and slip over top and sides of trim panels. Top ends of brass may need to be trimmed to fit (See Figure 4, Page 10).

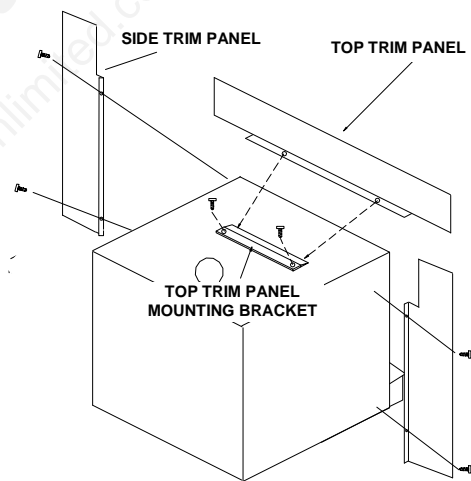

FIGURE 3 MOUNTING TRIM PANELS

10. Using insulation provided, peel and stick to back of panels overlapping fireplace dimensions by 1" on each side and top. (See Figure 4A).
11. Next using high heat silicone or furnace cement run heavy bead of caulking around where panels meet stove. (See Figure 4A).
12. Slide unit back into fireplace. Check to be sure that trim panels (and brass) are properly positioned and lie flat against front of fireplace. If panels are out of position, slide unit out and reset by loosening the mounting screws and repositioning in the slot. With bar lift stove up in front. Place insulation across front and surface of hearth or bottom of fireplace to make complete seal.
13. To check seal of panels, use candle flame and go around entire area sealed by silicone and insulation. If flame leans toward inside of fireplace, add additional insulation. This ensures an airtight seal.

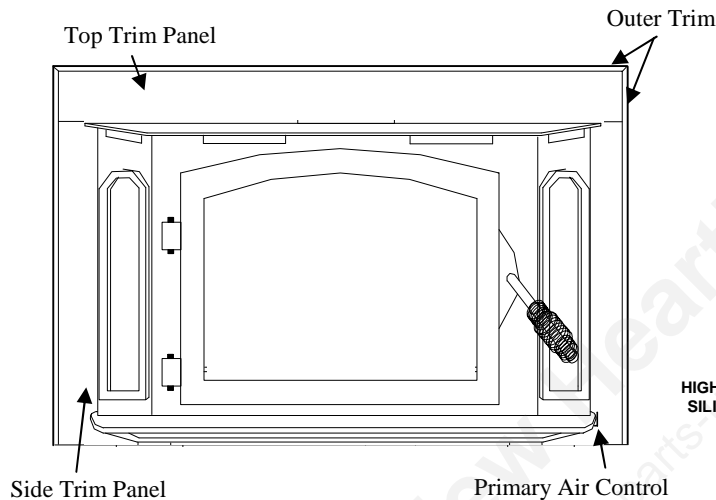

FIGURE 4

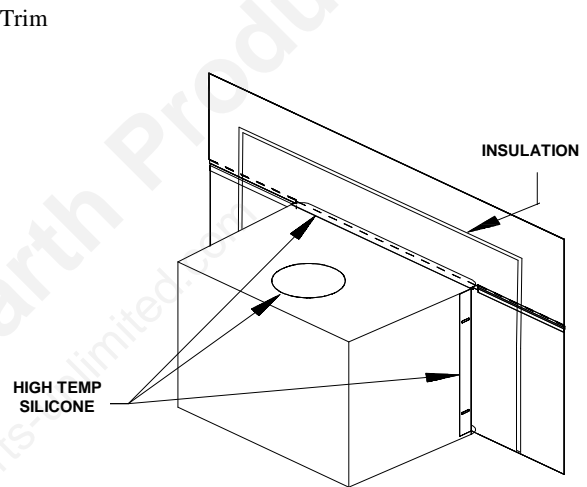

FIGURE 4A

FINAL CHECK

1. Recheck specified clearances.
2. Remove all foreign material from firebox area.
3. Open primary air control
Primary Air Control: The primary air intake draft control is located at right bottom side of hearth. It is operated by moving handle **out** to open (to allow air into firebox) or **in** (to control or close off) air into firebox. (See Figure 4).
4. Plug power cord into a 115V AC outlet. "Do not run power cord under unit or in high traffic areas.
5. Place crumpled pieces of newspaper in stove. Light it and close door. Ensure that stove draws properly through primary draft.

NOTE: "Do not use grate or elevate fire. Build wood fire directly on inner bottom of fire box."

6. Check for smoke leaks around door.
7. Open door and check for smoke escaping from front of stove. Smoking usually indicates a defective or poorly positioned chimney. Some chimneys with a marginal draft can be preheated by lighting newspaper and holding it near open damper with a poker or fire tong. Once the chimney heats up, a proper draft can usually be obtained.

If a thorough review of Troubleshooting Guide in rear of manual does not reveal problem, contact your dealer for assistance.

CAUTION

THE UNIT IS PAINTED WITH A SPECIALLY FORMULAR HIGH TEMPERATURE PAINT THAT CURES DURING FIRST TWO OR THREE FIRINGS. YOU MAY NOTICE A SLIGHT SMOKING EFFECT AND AN ODOR OF BURNING PAINT WHEN YOU BUILD FIRST FIRES. THIS IS NORMAL AND IS NOT A CAUSE FOR ALARM. IN SOME CASES, THESE FUMES WILL ACTIVATE A SMOKE ALARM. OPENING A WINDOW NEAR UNIT WILL ALLOW THESE FUMES TO ESCAPE. DO NOT BUILD A LARGE, ROARING FIRE UNTIL THIS CURING IS COMPLETE OR HEATER FINISH MAY BE DAMAGED.

The connector and/or chimney should be inspected at least once a month during heating season to determine if a creosote buildup has occurred.

CAUTION

NEVER USE GASOLINE, GASOLINE-TYPE LANTERN FUEL, KEROSENE, CHARCOAL LIGHTER FLUID OR SIMILAR LIQUIDS TO START OR "FRESHEN UP" A FIRE IN THE HEATER. KEEP ALL SUCH LIQUIDS WELL AWAY FROM THE STOVE WHEN IT IS IN USE. ALL FLUIDS OF THIS TYPE GIVE OFF VOLATILE FUMES AND CAN AND WILL EXPLODE!! DON'T TAKE A CHANCE WITH THE SAFETY OF YOUR HOME AND FAMILY.

SECTION III

PRE-FAB ZERO CLEARANCE INSERT INSTALLATION

The Model 18 may be installed into any UL listed prefabricated fireplace that is large enough to accept it.

MINIMUM CLEARANCES

Except for “**NOTE(S)**”, FOLLOW MASONRY INSTALLATION CLEARANCES FOUND IN YOUR OPERATIONS MANUAL.

INSTALLATION PREPARATION

Pre-Fab Zero Clearance Fireplace

1. Locate furniture and other materials away from front of fireplace to allow free access to fireplace.
2. Cover hearth and adjacent floor areas with drop cloths to protect from soiling or marring surface.
3. Remove existing fireplace damper plate/damper rod assembly.
4. Thoroughly clean fireplace of ashes and soot.
5. Check chimney and smoke chamber for excessive buildup of creosote or soot. Also, check for obstructions, such as bird’s nests. If chimney is excessively dirty, clean it or have someone clean it professionally **BEFORE** installing or using the room heater.
6. The Ash Lip, Smoke Baffle and Smoke Shelf may also be removed, if necessary, to provide room for Model 18. Any other alteration to unit will void ALL New Buck Corporation responsibility and liability. The **WARNING** label below must be attached to the back of fireplace.

WARNING: This fireplace must be restored to its original condition for safe use, if fireplace insert is removed.

NOTE: Plug power cord into a 115 VAC outlet. Route the cord to prevent damage to cord insulation from heat and sharp objects. Keep cord out of the way of traffic to prevent damage caused by tripping, etc.

NOTE: DO NOT BLOCK ANY EXISTING LOUVERS OR VENT ON EXISTING PREFAB WITH ANY TRIM PANELS FOR MODEL 18.

- To complete this installation, follow basic masonry fireplace trim kit instructions **EXCEPT:** The trim kit may have to be cut down in size so as not to block any cooling vents/chambers of Zero Clearance Fireplace
- Check installation minimum clearances and install an approved heater extension or floor protector to meet at least minimum clearances.

Mountain View Hearth Products
manuals.stove-parts-unlimited.com

SECTION IV

RESIDENTIAL FREESTANDING INSTALLATION

Select an installation location that will give best airflow from front of heater to remainder of home.

PREPARING STOVE FOR INSTALLATION

1. Inspect unit for any obvious physical damage.
2. Plug power cord into a 115V AC outlet. Do not run power cord under unit or in high traffic areas.
3. Check primary air draft control to ensure that it slides freely. (See Figure 5).
4. Remove any items from within firebox. Spread a dropcloth one floor behind heater. Next, tilt heater so that back is on drop cloth.
5. **(Leg Kit):** If legs are to be used, obtain four legs, attach legs to holes in bottom of unit with bolts and washers supplied with leg kit. (See Figure 5).
6. **(Pedestal Kit):** If pedestal kit is being used and **(out side air is required for residential free standing installation (see page 29 Out Side Air Installation))**. Open freestanding kit and obtain stand. Place stand against bottom of heater (angle side to heater). Center stand front to rear and also center stand left and right. Mark screw locations on bottom of stove through outer holes of stand mounting angles. Set stand aside and drill four 7/32" holes in heater bottom. Then mount stand to bottom of heater with screws provided. (See Figure 5A).
7. Obtain four (4) 3/16" self-tapping screws and secure stand to heater.
8. Reposition heater to upright position.

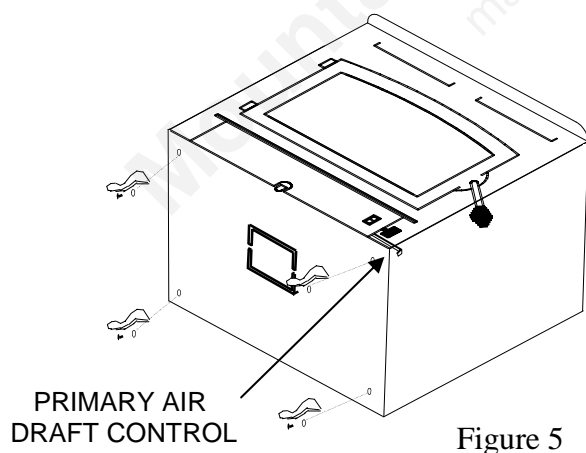

Figure 5

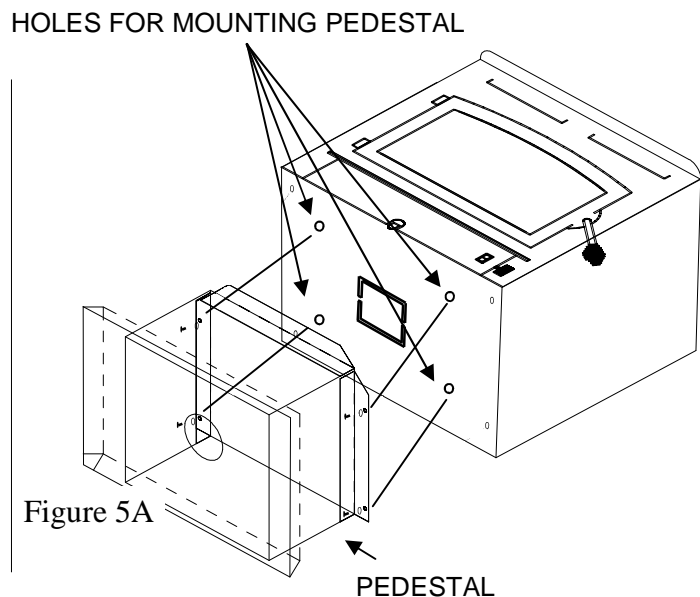

Figure 5A

ALTERNATE FLOOR PROTECTORS MATERIAL

Floor protection must be 3/8" minimum thickness non-combustible material or equivalent.

How to use alternate materials and how to calculate equivalent thickness

An easy means of determining if a proposed alternate floor protector meets requirements listed in the appliance manual is to follow this procedure:

1. Convert specification to R-value:
 - R-value is given—no conversion is needed.
 - K-factor is given with a required thickness (T) in inches:
C-factor is given: $R=1/C$
2. Determine the R-value of the proposed alternate floor protector.
 - Use the formula in step (1) to convert values not expressed as "R"
 - For multiple layers, add R-values of each layer to determine the overall R-value.
3. If the overall R-value of the system is greater than the R-value of the specified floor protector, the alternate is acceptable.

Example:

The specified floor protector should be 3/4" thick material with a K-factor of 0.84.
The proposed alternate is 4" brick with a C-factor of 1.25 over 1/8" mineral board with a K-factor of 0.29.

Step (a): Use formula above to convert specification to R-value. $R = 1/K \times T = 1/0.84 \times .75 = 0.893$

Step (b): Calculate R of proposed system. 4" brick of $C=1.25$, therefore $R_{brick} = 1/C = 1/1.25 = 0.80$
1/8" mineral board of $K = 0.29$, therefore $R_{min.bd.} = 1/0.29 \times 0.125 = 0.431$

Step (c): Compare proposed system R of 1.231 to specified R of 0.893. Since proposed system R is greater than required, the system is acceptable.

Definitions:

$$\text{Thermal conductance} = C = \frac{\text{Btu}}{(\text{hr})(\text{ft}^2)(\text{°F})} = \frac{\text{W}}{(\text{m}^2)(\text{°K})}$$

$$\text{Thermal conductance} = K = \frac{(\text{Btu})(\text{inch})}{(\text{hr})(\text{ft}^2)(\text{°F})} = \frac{\text{W}}{(\text{m})(\text{°K})} = \frac{(\text{Btu})}{(\text{hr})(\text{tf})(\text{°F})}$$

$$\text{Thermal conductance} = R = \frac{(\text{ft}^2)(\text{hr})(\text{°F})}{\text{Btu}} = \frac{(\text{m}^2)(\text{°K})}{\text{W}}$$

Install in accordance with 24 CFR, Part 3280 (HUD).

SECTION VI

RESIDENTIAL FREESTANDING INSTALLATION MINIMUM CLEARANCES TO COMBUSTIBLES

FREESTANDING INSTALLATION CLEARANCES FOR MODEL -18

NOTE: All clearances are to combustibles without low clearance shields and using single

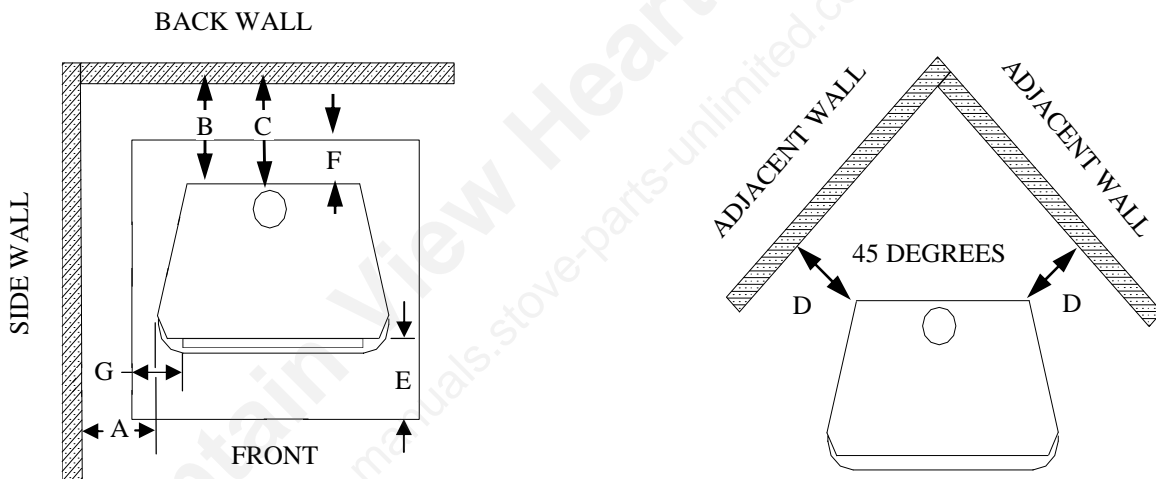

wall pipe and minimum floor protector. Clearances above may be reduced. Follow NFPA-211 codes if available or follow instructions (see pages 24 and 25).

	A	B	C	D	E	F	G
MODEL 18	10"	14"	15"	9"	16"	8"	8"

* Floor Protector at rear needed for through-the-wall exit only.

CHIMNEY

CEILING EXITS:

This model is designed for connection to any 2100° UL 103 HT chimneys. Follow chimney manufactures instructions carefully.

NOTE: This room heater must be converted to (1) a chimney complying with requirements for Type HT chimneys in Standard for chimneys, Factory-Built, Residential, Type and Building Heating Appliance, UL 103, or (2) a code approved masonry chimney with a flue liner. The chimney size should not be less than nor more than 3 times greater than cross-sectional area of flue collar.

CAUTION

SPECIAL METHODS ARE REQUIRED WHEN PASSING THROUGH A WALL OR CEILING. SEE INSTRUCTIONS AND BUILDING CODES.

DETERMINING CHIMNEY LOCATION

A. **CEILING EXIT** Using 6" Single Wall Pipe and UL 103 HT type chimney system listed with manufacturer in this section of manual.

1. Suspend a plumb bob from ceiling above unit so that weight is hanging in center of flue exit. (A small weight on a string will serve as a plumb bob). Mark ceiling where string is suspended to locate center of chimney.
2. After locating center of hole, install ceiling support box, chimney flashing and rain cap per chimney manufacturer's instructions.
3. Now connect stove and ceiling support box using #24 ga. minimum blued or black steel connector pipe (**DO NOT USE GALVANIZED PIPE**). Connect each section so crimped end faces downward, and secure each section to each other using at least three (3) sheet metal screws or rivets. Also use three (3) sheet metal screws to fasten pipe to collar on heater (See Page 20, Figure 6) or you may use 3 "EII" brackets fastened to top of heater and fastened to stove pipe.

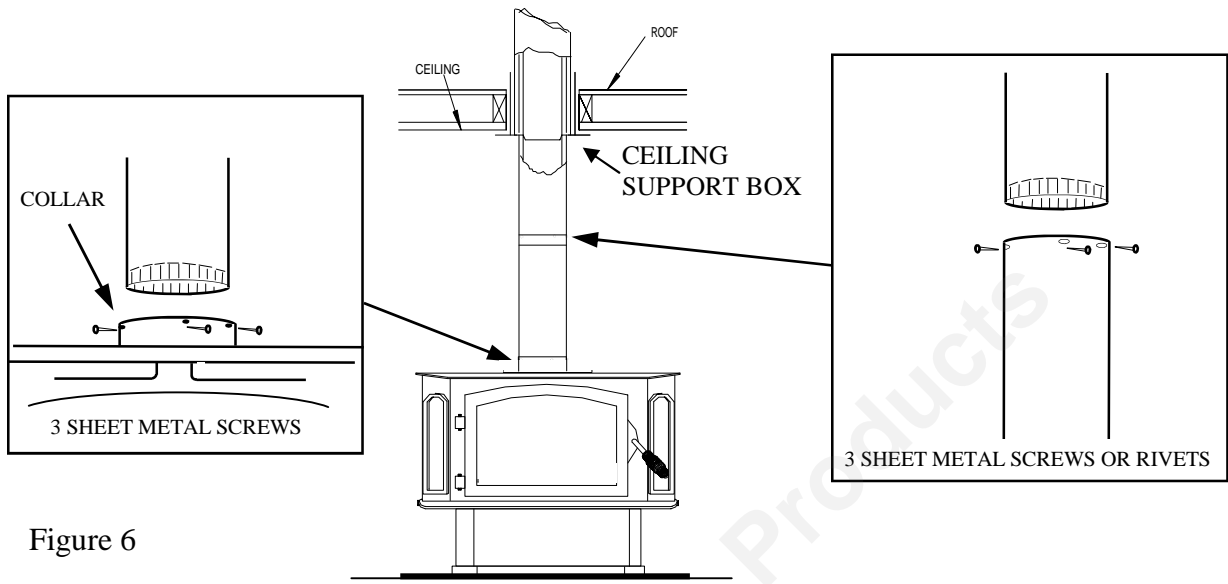

Figure 6

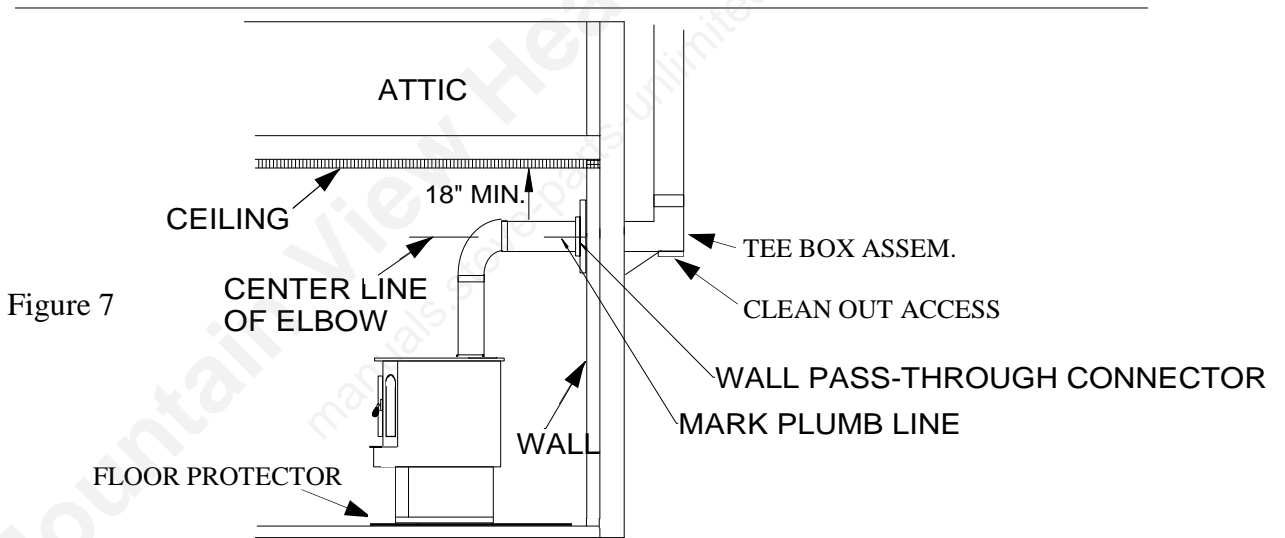

Figure 7

B. WALL EXIT INTO METAL TEE-BOX

1. Mark plumb line on wall directly behind center of heater. (See Figure 7).

NOTE: When using 24# ga. minimum blue or black steel pipe, maintain 18" between pipe and ceiling.

2. Place vertical portion of heater pipe and elbow in position and project a point onto plumb line level with center of elbow.

3. Measure, so there will be at least 1/4" rise per foot of horizontal connector pipe, maintaining clearances to ceiling as noted in Figure 7, Page 20. This will give you center of hole for chimney penetration.
4. After locating center of penetration, install tee box and chimney as per chimney manufacturer's specifications.
5. Connect chimney collar to tee-box using #24 ga. minimum blued or black steel connector pipe. **DO NOT** use galvanized pipe. Connect each section so the crimped end faces downward, and secure each section to each other using three (3) sheet metal screws or rivets.

C. WALL EXIT INTO MASONRY (USING SINGLE WALL PIPE)

1. Before connecting these units to a masonry chimney, determine that masonry fireplace wall pass-through connector thimble meets **NFPA-211** Code and local building codes and is a minimum of 18" from ceiling. If connector thimble does not meet these codes, pass-through connector must be modified. (See Figure 8).

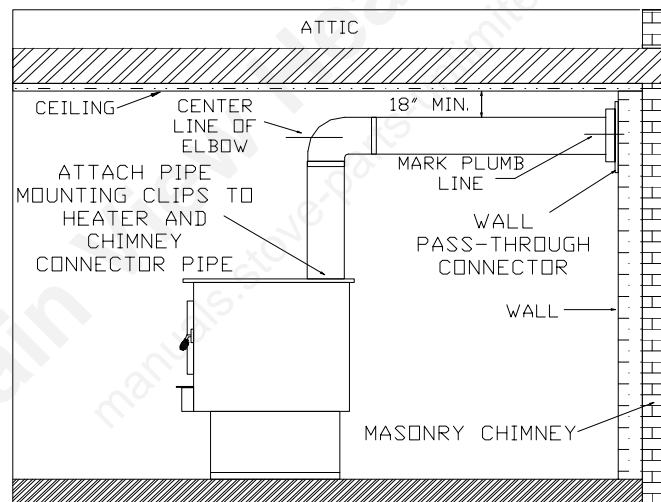

Figure 8

Connectors may pass through walls or partitions constructed of combustible material if connector is:

- (a) Either listed for wall pass-through or is routed through a device listed for wall pass-through and is installed in accordance with conditions of listing.
- (b) Selected or fabricated in accordance with the conditions and clearances as stated in table 6-7.5 of the 2000 **NFPA 211** Code. Any unexposed metal that is used as part of a wall pass-through system and is exposed to flue gases shall be constructed of stainless steel or other equivalent material that will resist corrosion, softening, or cracking from flue gases at temperatures up to 1800° F.

NOTE: In addition, a connector to a masonry chimney shall extend through wall to inner face or liner but not beyond, and shall be firmly cemented to masonry.

Exception: A thimble may be used to facilitate removal of the chimney connector for cleaning, in which case thimble shall be permanently cemented in place with high-temperature cement.

2. Once through-the-wall thimble codes are met, simply connect chimney collar to wall pass-through connector using #24 ga. minimum, blued or black steel connector pipe as follows:

- (a) Maintain 1/4" rise per foot (horizontal length) from appliance to the chimney.
- (b) Connect each section so crimped end faces downward or back toward unit.
- (c) Secure each section to each other using at least three (3) sheet metal screws or rivets.
- (d) Use three (3) sheet metal screws to fasten pipe to connector collar on heater.

D. CEILING EXIT - CLOSE CLEARANCE

1. Suspend a plumb bob from ceiling above unit so that weight is hanging in center of flue exit. (A small weight on a string will serve as a plumb bob.) Mark ceiling where string is suspended to locate center of chimney hole.
2. After locating center of hole, install ceiling support box, chimney flashing and rain cap.
3. Next, install an optional New Buck Corporation chimney connector to flue exit of heater or you may use "Ell" brackets to fasten pipe to stove. See (Page 23, Figure 9).
4. Install Single Wall Connector and chimney system per manufacturer's written operating instructions. See manufacturer's list of tested pipes in this manual.

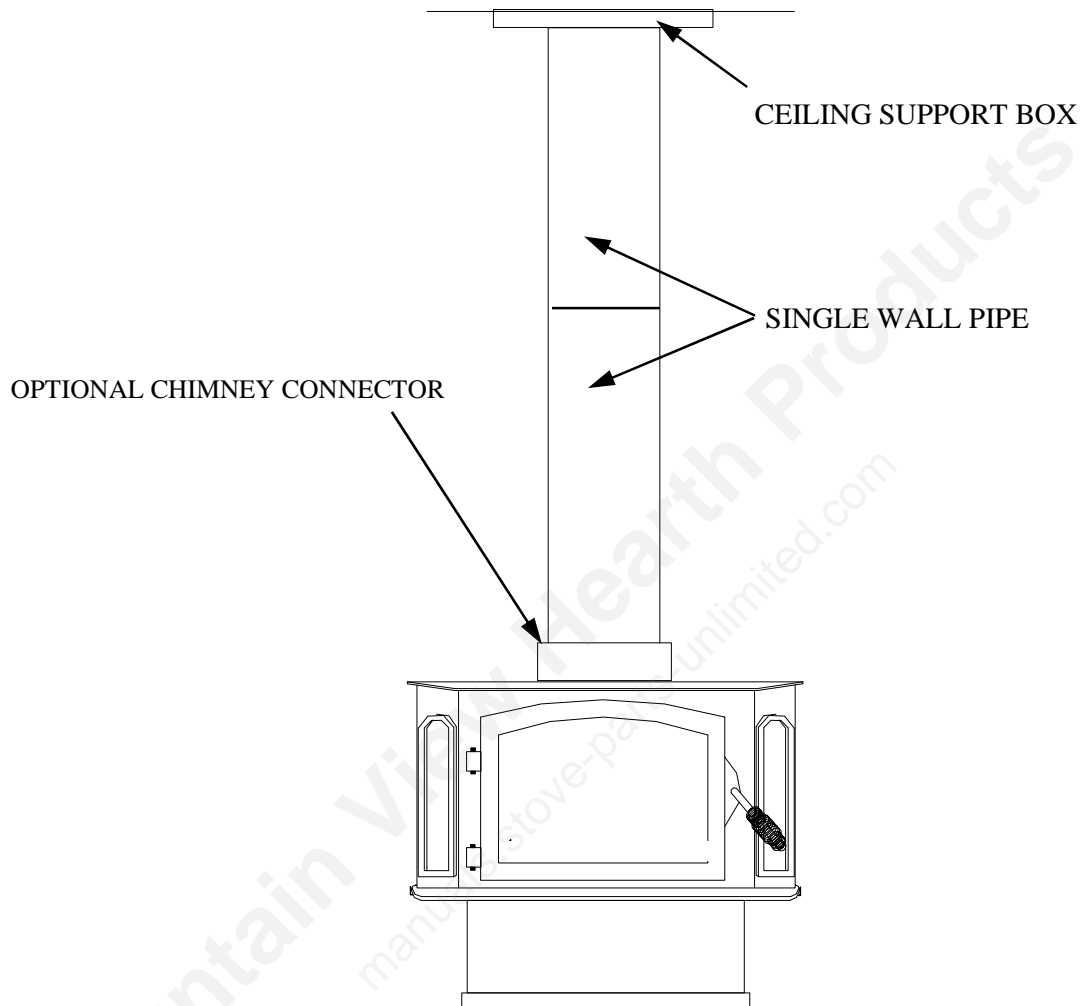

Figure 9

Close Clearance Installation using: (1) 6" Simpson Dura-Vent single wall chimney connector (Dura Black) and 6" Simpson Dura-Vent 2100 Deg HT (Type DP) chimney or (2) 6" Metal Fab Type single wall connector and 6" Metal Fab 2100 HT chimney or (3) Ameritec. For Minimum Clearances see page 18.

ALCOVE INSTALLATION CLEARANCES

Must use 6" single wall connector and 6" Type HT pipe listed for Close Clearance reduction listed in this manual. For Minimum Clearances see below.

NOTE: Must also use Close Clearance Shield kit

NOTE: Clearances to be used with double wall pipe and low clearance shield.

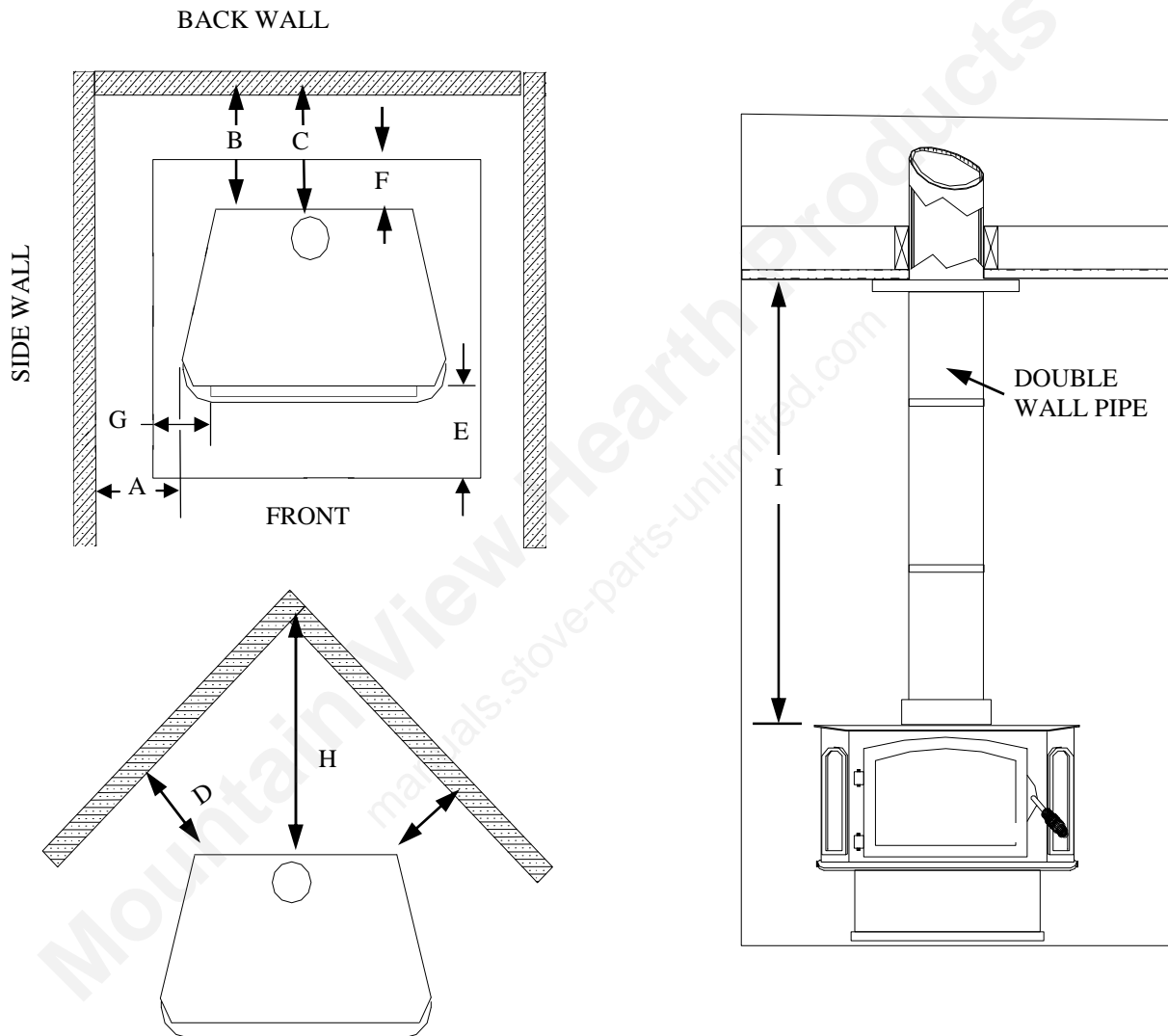

FIGURE 10

	A	B	C	D	E	F	G	H	I
MODEL 18	8"	10"	12"	7"	16"	8"	8"	14"	34"

* Floor Protector at rear needed for through-the-wall exit only.

FINAL CHECK

1. Recheck specified clearances.
2. Remove all foreign material from firebox area.
3. Open primary air draft.

NOTE: Plug power cord into a 115 VAC outlet. Route cord to prevent damage to cord insulation from heat and sharp objects. Keep cord out of way of traffic to prevent damage caused by tripping, etc.

4. Place crumpled pieces of newspaper in stove. Light it and close door. Ensure that stove draws properly through primary draft.
5. Check for smoke leaks around door.

CAUTION

Open door and check for smoke escaping from front of stove. Smoking usually indicates a defective or poorly positioned chimney. Some chimneys with a marginal draft can be preheated by lighting newspaper and holding it near open damper with a poker or fire tong. Once chimney heats up, a proper draft can usually be obtained.

If a thorough review of Troubleshooting Guide in rear of manual does not reveal problem, contact your dealer for assistance.

CAUTION

The unit is painted with a specially formulated high temperature paint that cures during first two or three firings. You may notice a slight smoking effect and an odor of burning paint when you build first fires. This is normal and is not a cause for alarm. In some cases, these fumes will activate a smoke alarm. Opening a window near unit will allow these fumes to escape. DO NOT build a large roaring fire until this curing is complete or heater finish may be damaged.

SECTION V

FREESTANDING MOBILE HOME INSTALLATION

NOTE: See page 27 for clearances for Mobile Home.

FLOOR PROTECTION

Floor protection must be 3/8" minimum thickness non-combustible material or equivalent.

How to use alternate materials and how to calculate equivalent thickness

An easy means of determining if a proposed alternate floor protector meets requirements listed in the appliance manual is to follow this procedure:

1. Convert specification to R-value:
 - R-value is given—no conversion is needed.
 - K-factor is given with a required thickness (T) in inches:
 - C-factor is given: $R=1/C$
2. Determine the R-value of the proposed alternate floor protector.
 - Use the formula in step (1) to convert values not expressed as "R"
 - For multiple layers, add R-values of each layer to determine the overall R-value.
3. If the overall R-value of the system is greater than the R-value of the specified floor protector, the alternate is acceptable.

Example:

The specified floor protector should be 3/4" thick material with a K-factor of 0.84.
The proposed alternate is 4" brick with a C-factor of 1.25 over 1/8" mineral board with a K-factor of 0.29.

Step (a): Use formula above to convert specification to R-value. $R= 1/K \times T = 1/0.84 \times .75 = 0.893$

Step (b): Calculate R of proposed system. 4" brick of $C=1.25$, therefore $R_{brick} = 1/C = 1/1.25 = 0.80$ 1/8" mineral board of $K = 0.29$, therefore $R_{min.bd.} = 1/0.29 \times 0.125 = 0.431$

Step (c): Compare proposed system R of 1.231 to specified R of 0.893. Since proposed system R is greater than required, the system is acceptable.

Definitions:

$$\text{Thermal conductance} = C = \frac{\text{Btu}}{(\text{hr})(\text{ft}^2)(\text{°F})} = \frac{W}{(\text{m}^2)(\text{°K})}$$

$$\text{Thermal conductance} = K = \frac{(\text{Btu})(\text{inch})}{(\text{hr})(\text{ft}^2)(\text{°F})} = \frac{W}{(\text{m})(\text{°K})} = \frac{(\text{Btu})}{(\text{hr})(\text{ft})(\text{°F})}$$

$$\text{Thermal conductance} = R = \frac{(\text{ft}^2)(\text{hr})(\text{°F})}{\text{Btu}} = \frac{(\text{m}^2)(\text{°K})}{W}$$

Install in accordance with 24 CFR, Part 3280 (HUD).

RESIDENTIAL FREESTANDING INSTALLATION AND MOBILE HOME INSTALLATIONS MINIMUM CLEARANCES TO COMBUSTIBLES USING SINGLE WALL PIPE AND LOW CLEARANCE SHIELDS

CLEARANCES FOR MODEL -18

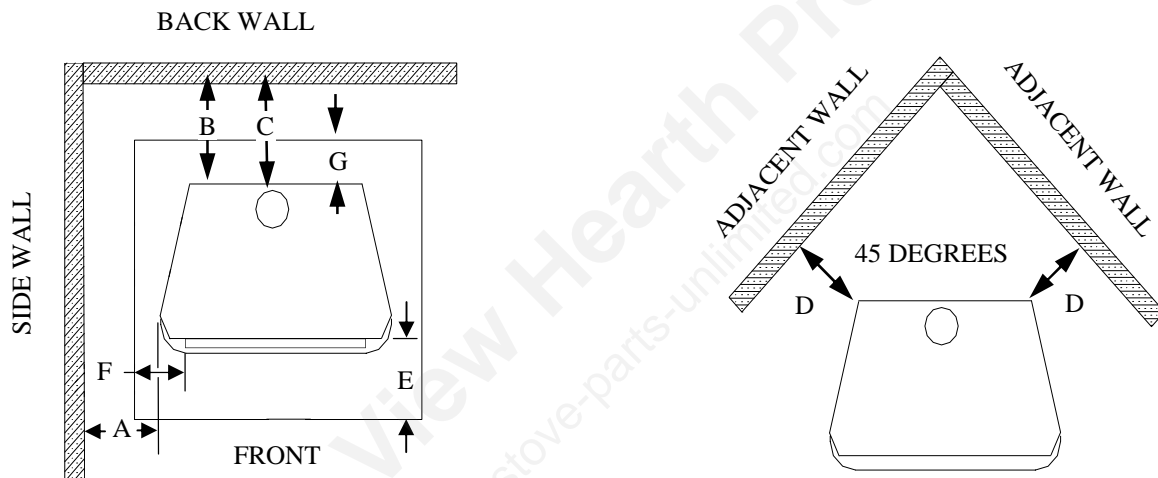

Figure 11

	A	B	C	D	E	F	G
MODEL 18	8"	10"	12"	7"	16"	8"	8"

NOTE: All clearances are to combustibles using single wall pipe and all optional low clearance shields and minimum floor protector.

*Floor protector at rear needed for through-the-wall exit only.

INSTALLATION OF (OPTIONAL) CLOSE CLEARANCE SHIELDS

1. Center rear close clearance shield with back of stove. Mark rear of stove, using reference holes in rear shield. Using self-tapping screws, drill four holes in locations marked. Remove screws and attach rear shield to back of stove. see figure 11A.
2. Insert front end of side shield behind side angle on front side of stove. Align top of side shield with top of rear shield. Mark holes on rear shield thru holes in rear of side shield. Using four self tapping screws drill four holes in the locations marked. Tighten bottom screws and leave top screws loose for step 3. Use same step to install side shield on the opposite side of stove. See figure 11B.
3. Loosen two top screws holding side shield at rear top. Insert pipe shield where back shield and top rear side shield meets. Tighten screws. see figure 11C.

REAR CLOSE
CLEARANCE SHIELD

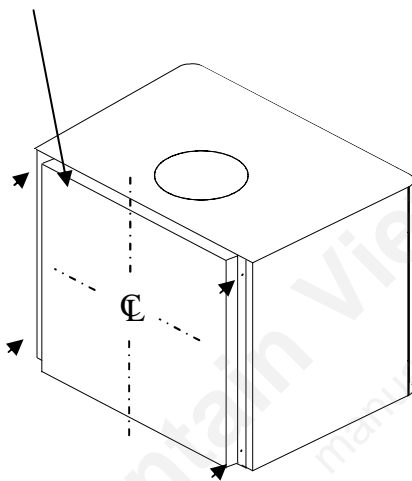

Figure 11A

SIDE SHIELD'S

Keep rear / side
Shields even

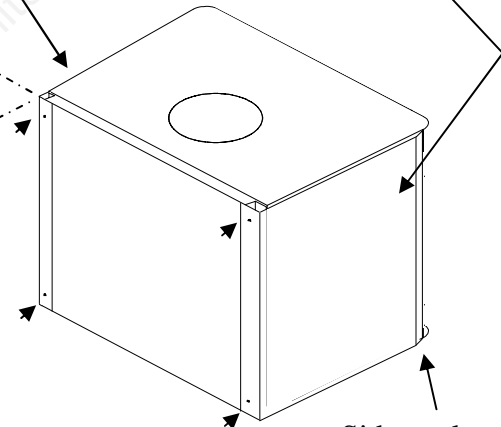

Figure 11B

Side angle on
front side of
stove.

PIPE SHIELD

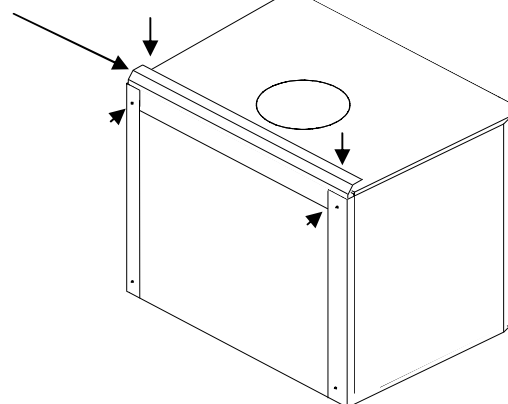

Figure 11C

TOOLS FOR INSTALLATION

Drop cloth, 3/32" Metal drill bit, 5/16" magnetic socket chuck adapter, 5/16" wrench (box or socket) or adjustable wrench, Jigsaw with masonry, metal and wood blades

WARNING: DO NOT INSTALL IN A SLEEPING ROOM.

PREPARING STOVE FOR INSTALLATION

1. Remove protective plastic wrapping from unit, inspect unit for any obvious physical damage.
2. Plug power cord into a 115V AC outlet. "Do not run power cord under unit or in high traffic areas". Unplug power cord when installing or moving unit.
3. Check primary air draft control to ensure that it slides freely. (See Figure 12).
4. Remove any items from within firebox. Spread a dropcloth on floor behind heater. Next, tilt heater so that back is on drop cloth.
5. **(Leg Kit):** If legs are to be used, obtain four legs, attach legs to holes in bottom of unit with bolts and washers supplied with leg kit. (See Figure 12).
6. **(Pedestal Kit):** If pedestal kit is being used (**and outside air is required see below, Out Side Air Installation**).
Open freestanding kit and obtain stand. Place stand against bottom of heater (angle side to heater). Center stand front to rear and also center stand left and right. Mark screw locations on bottom of stove through outer holes of stand mounting angles. Set stand aside and drill four 7/32" holes in heater bottom. Before attaching heater to stand, take a large flat screwdriver or pliers and remove 2" x 2" knockout on bottom of unit. (See Figure 12A). Then mount stand to bottom of heater with screws provided. (See Figure 12A).
7. Obtain four (4) 3/16" self-tapping screws and secure stand to heater.
8. Reposition heater to upright position.

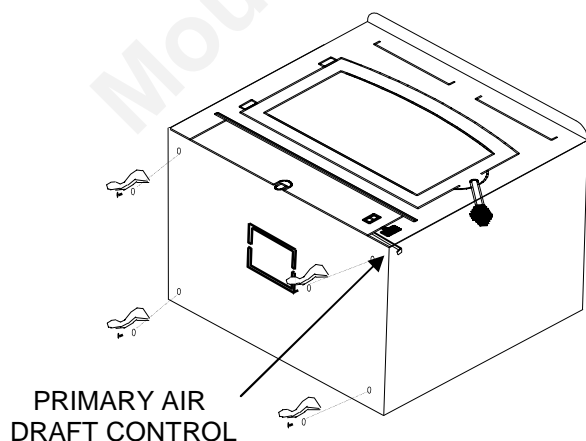

Figure 12

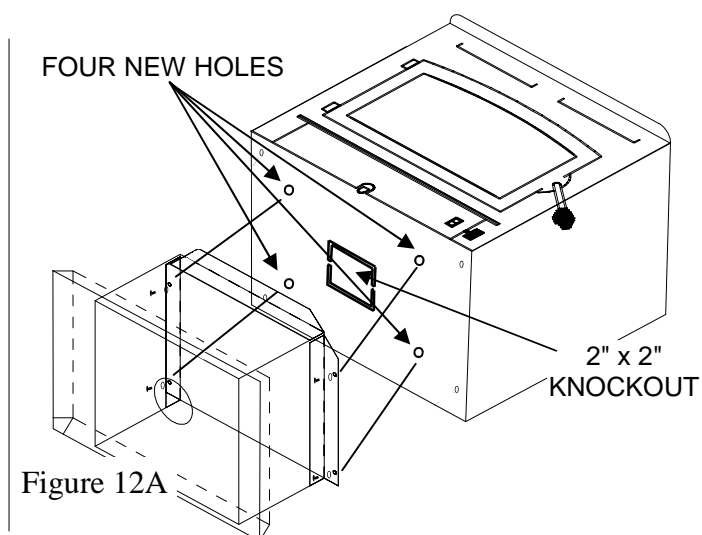

Figure 12A

OUT SIDE AIR INSTALLATION

CAUTION

THE STRUCTURAL INTEGRITY OF THE MOBILE HOME FLOOR MUST BE MAINTAINED. (MOVE OPENING AND/OR REPOSITION HEATER LOCATION IF NECESSARY).

1. Select an installation location that will give best airflow from front of heater to remainder of home.
2. Place protective floor pad in position. For minimum floor protection (See Page 26).
3. Place unit on pad making sure minimum clearance specifications are met. For minimum clearance to combustibles (See Page 27).
4. Lightly mark with a pencil location of pedestal on protective pad.
5. Next, remove four (4) screws holding heater to stand. Position heater out of way of installation area.
6. Check that pedestal stand is still aligned with marks on protective pad, now mark outside air opening in bottom of pedestal stand on to pad.
7. Mark center line of outside air opening. Set stand aside for now.
8. Cut a 4 1/4" diameter hole in pad and continue through floor.

CAUTION!!

THE STRUCTURAL INTEGRITY OF THE HOME FLOOR MUST BE MAINTAINED. (MOVE OPENING AND/OR REPOSITION HEATER LOCATION IF NECESSARY).

9. Now, reposition pedestal stand and set on pad being sure to line stand up with reference marks.
10. Using an electric drill and 3/8" masonry bit, drill four (4) holes in protective pad using holes in bottom of pedestal stand as a guide. Be careful to drill only through pad and not into floor. Change bit to a 1/4" metal bit and drill through floor.
11. Using four (4) 3/8" x 1-1/2" lag bolts provided, secure pedestal stand and pad to floor of home.

CAUTION:

IF A THICK FLOOR PROTECTOR IS USED, YOU MAY HAVE TO USE LONGER LAG BOLTS.

12. Obtain outside air duct from the box in pedestal kit marked FA P21B.
13. Slip duct down through 4-1/4" hole until face of outside air duct with screen wire, contacts bottom of pedestal.
14. Secure outside air duct to inside bottom of pedestal using the four (4) #10x1 screws provided. (See Figure 13).
15. Set heater back onto stand and resecure using screws.

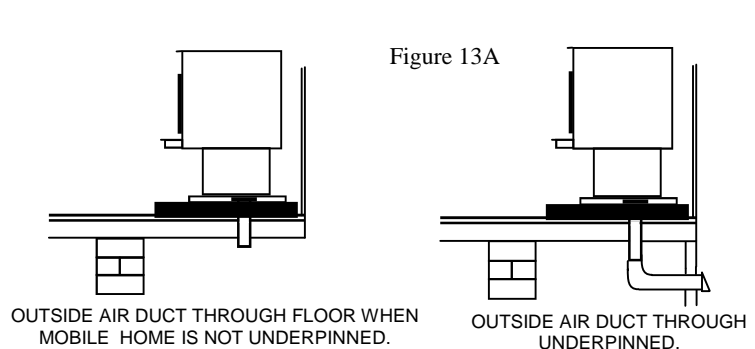
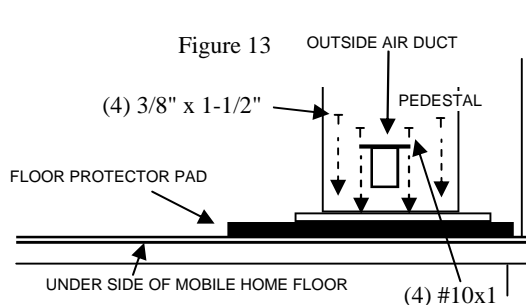

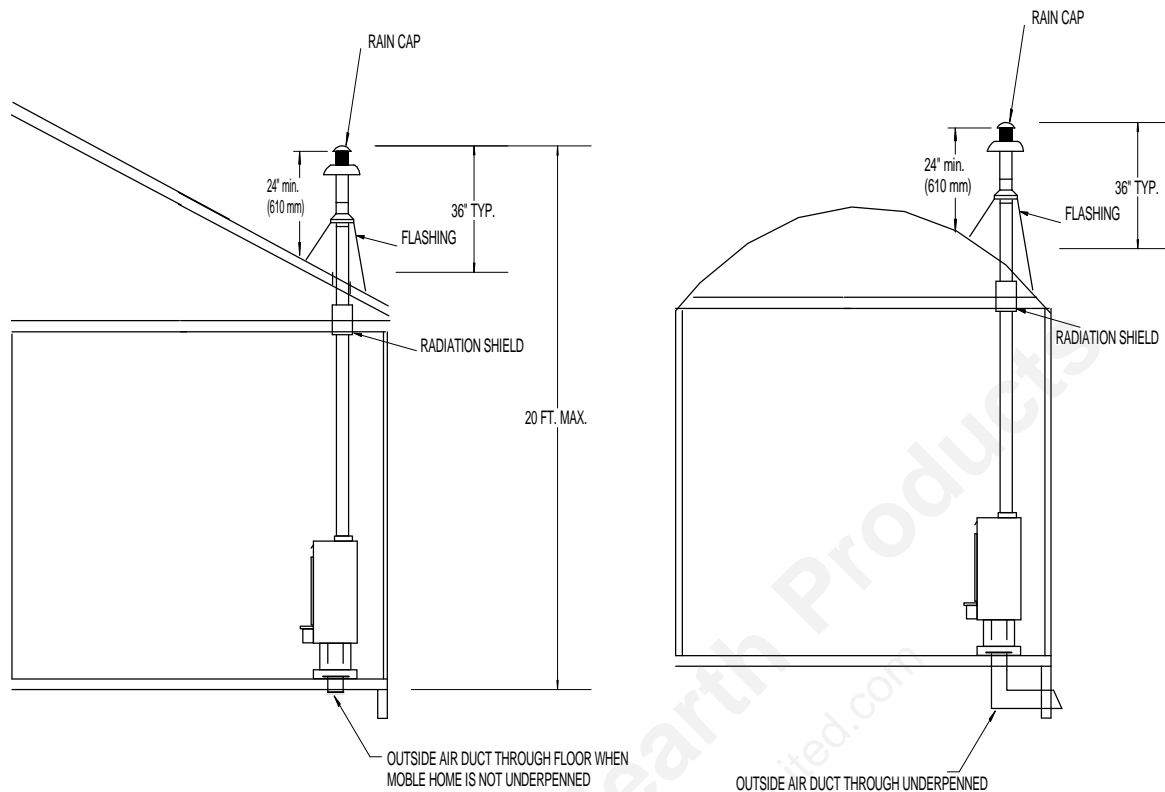

Figure 12

FOR CEILING EXIT USING CLOSE CLEARANCE LISTED CHIMNEY

1. Suspend a plumb bob from ceiling above unit so that weight is hanging in center of flue exit. (A small weight on a string will serve as a plumb bob). Mark ceiling where string is suspended to locate center of chimney hole.
2. After locating center of hole install ceiling support box, chimney, flashing and rain cap using listed chimney only. Only use pipe listed in this manual.

CAUTION

REFER TO CHIMNEY MANUFACTURER'S INSTRUCTIONS FOR ASSEMBLY AND DISASSEMBLY OF CHIMNEY PARTS. BE SURE TO FOLLOW CHIMNEY INSTRUCTIONS FOR PROPER CLEARANCES TO COMBUSTIBLE AND PROPER AIR SPACING REQUIRED.

3. Add additional pipe until **both** of the following are met:
 - (a) Chimney pipe is 3 feet higher than roof at point where it penetrates roof and

- (b) Chimney pipe height is at least 2 feet higher than any part of roof within 10 feet of chimney. See (Page 31, Figure 12).
- Next, install a New Buck Corporation chimney connector to flue of heater or use 3 “ELL” brackets and secure to top of heater and pipe.
 - Using single wall chimney connector, connect heater to chimney by following manufacturer's installation instructions exactly. (See Figure 15).

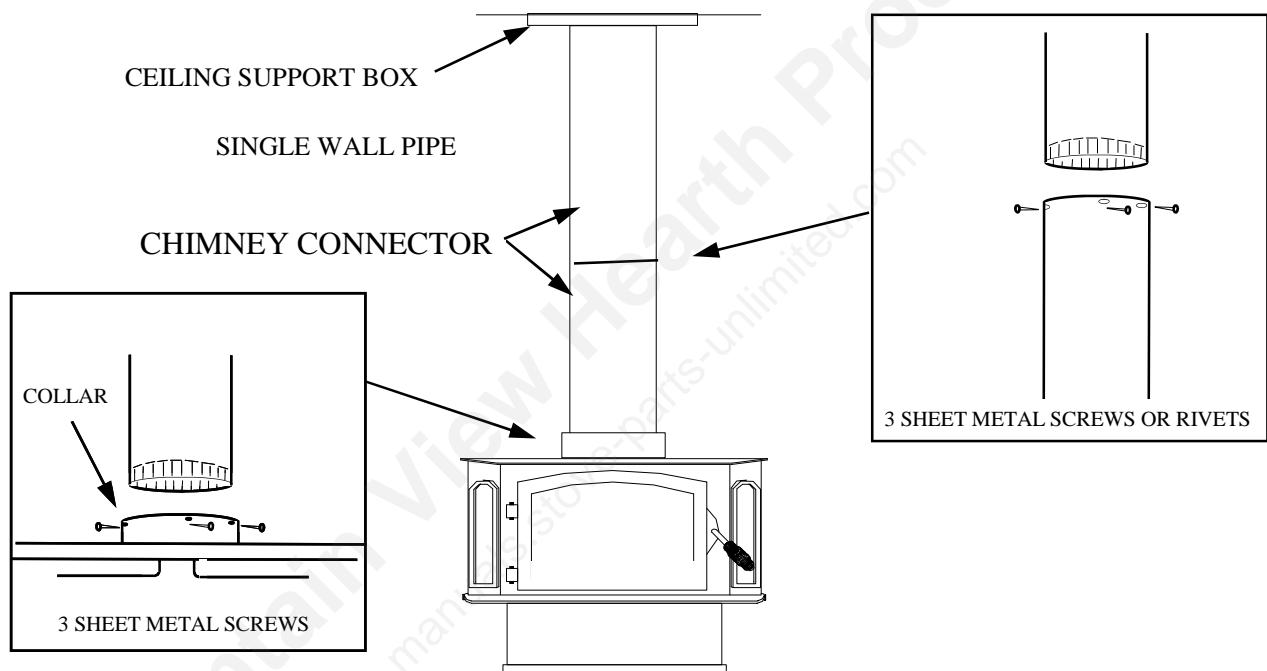

Figure 15

FINAL CHECK

1. Recheck specified clearances.
2. Remove all foreign material from firebox area.
3. Open primary air draft.

NOTE: Plug power cord into a 115 VAC outlet. Route cord to prevent damage to cord insulation from heat and sharp objects. Keep cord out of way of traffic to prevent damage caused by tripping, etc.

4. Place crumpled pieces of newspaper in stove. Light it and close door. Ensure that stove draws properly through primary draft.
5. Check for smoke leaks around door.
6. Open door and check for smoke escaping from front of stove. Smoking usually indicates a defective or poorly positioned chimney. Some chimneys with a marginal draft can be preheated by lighting newspaper and holding it near open damper with a poker or fire tong. Once chimney heats up, a proper draft can usually be obtained.

If a thorough review of Troubleshooting Guide in rear of manual does not reveal problem, contact your dealer for assistance.

CAUTION

THE UNIT IS PAINTED WITH A SPECIALLY FORMULATED HIGH TEMPERATURE PAINT THAT CURES DURING FIRST TWO OR THREE FIRINGS. YOU MAY NOTICE A SLIGHT SMOKING EFFECT AND AN ODOR OF BURNING PAINT WHEN YOU BUILD FIRST FIRES. THIS IS NORMAL AND IS NOT A CAUSE FOR ALARM. IN SOME CASES, THESE FUMES WILL ACTIVATE A SMOKE ALARM. OPENING A WINDOW NEAR UNIT WILL ALLOW THESE FUMES TO ESCAPE. DO NOT BUILD A LARGE ROARING FIRE UNTIL THIS CURING PROCESS IS COMPLETE OR HEATER FINISH MAY BE DAMAGED.

SECTION VI

WOOD HEATER SAFETY

Certain safety hazards are inherent in any wood heater installation. You should be aware of these so that a safe and proper installation can be made.

1. **FAULTY CHIMNEY:** An older masonry chimney should be thoroughly checked to be sure there are no holes or weak spots which could allow sparks or hot gases to escape.
2. **HEAT CONDUCTION:** Placing combustible materials too close to a heater or chimney can be a fire hazard.

By keeping these particular hazards in mind as you install and use your room heater you can ensure a safe, reliable installation.

FOR PREFAB INSTALLATION:

The chimney and chimney connector should be inspected once every two months. Any build-up of soot should be removed to prevent risk of a chimney fire

FOR FREE STANDING INSTALLATION:

The chimney and chimney connector should be inspected once every two months. Any build-up of soot should be removed to prevent risk of a chimney fire. To remove chimney or chimney connector: Remove screws or fasteners. Remove pipe and clean with steel brush. Replace chimney or chimney connector, and replace screws and/or fasteners.

CAUTION

NEVER USE GASOLINE, GASOLINE TYPE LANTERN FUEL, KEROSENE, CHARCOAL LIGHTER FLUID OR SIMILAR LIQUIDS TO START OR "FRESHEN UP" A FIRE IN THE HEATER. KEEP ALL SUCH LIQUIDS WELL AWAY FROM STOVE WHEN IT IS IN USE. ALL FLUIDS OF THIS TYPE GIVE OFF VOLATILE FUMES AND CAN AND WILL EXPLODE!! DON'T TAKE A CHANCE WITH THE SAFETY OF YOUR HOME AND FAMILY.

CAUTION

Never remove ashes from heater with blower running.

DISPOSAL OF ASHES:

Ashes should be placed in a metal container with a tight fitting lid. The closed container of ashes should be placed on a non-combustible floor or on ground, well away from all combustible materials pending final disposal. If ashes are disposed of by burial in soil or otherwise locally dispersed, they should be retained in closed container until all cinders have thoroughly cooled.

CREOSOTE - FORMATION AND NEED FOR REMOVAL:

When wood is burned slowly, it produces tar and other organic vapors, which combine with expelled moisture to form creosote. The creosote vapors condense in relatively cool chimney flue of a slow-burning fire. As a result, creosote residue accumulates on flue lining. When ignited this creosote makes an extremely hot fire.

SECTION VII

HEATER OPERATION

This section of manual is to help you get maximum efficiency and maximum smoke (particulate) reduction from your heater. If you should experience any difficulty or have any questions concerning your heater, contact your dealer for assistance.

NOTE: The manufacturer recommends that for maximum performance burn natural seasoned hard wood.

Build a fire for maximum efficiency. These models burn wood and extract heat so efficiently a large fire is not necessary. A large fire not only wastes energy, it usually results in home being too warm for comfort.

The following steps will serve as a guide for operating your stove.

BUILDING A FIRE

1. Open door.
2. Open primary air control located on right side of stove under hearth. To close push all way in. To open pull all way out.
3. Twist two pieces of non-colored newspaper into a roll and place them on floor of firebox.

NOTE: "Do not use grate or elevate fire. Build wood fire directly on inner bottom of fire box."

4. These models are not designed for use of grates, andirons or other methods of supporting fuel.
5. Lay several pieces of dry kindling on top of newspaper.
6. Place three or four small pieces of firewood, 2-3" in diameter, on top of kindling.
7. Light newspaper in front. Close and latch door. Don't leave fire unattended at this point. The draft system of heater should start quickly. It may be necessary to preheat chimney to get draft started. To do this, open door and add newspaper to top rear of wood. Light or let this paper ignite and allow to burn while holding door slightly cracked. Once draft has started, close and lock door. You are over heating unit if chimney and or connector glows red.

8. **NOTE: After embers and a coal bed have been established, load heater with seasoned natural hard wood wood, placing it length way front to rear.**

NOTE: THE FUELING DOOR MUST REMAIN CLOSED DURING OPERATION.

NOTE: If the blower is being used on the Model 18 Non-Cat, your stove is equipped with a automatic thermostat. When the stove gets hot enough, thermostat will activate room air blower.

NOTE: When refueling or removing ashes from unit, unplug room air blower from outlet to prevent damage from coals or ashes. Be sure to plug room air blower back in when finished.

NOTE: Do not run power cord underneath heater or in walk way or heavy traffic areas.

SECTION VIII

OPERATION FOR ROOM AIR BLOWER AND MAINTENANCE

Your heater is equipped with a room air blower. For operation and wiring see below.

Operation.

After heater has warmed up the thermostat will automatically turn on blower. When the stove cools off, thermostat will automatically shut off blower.

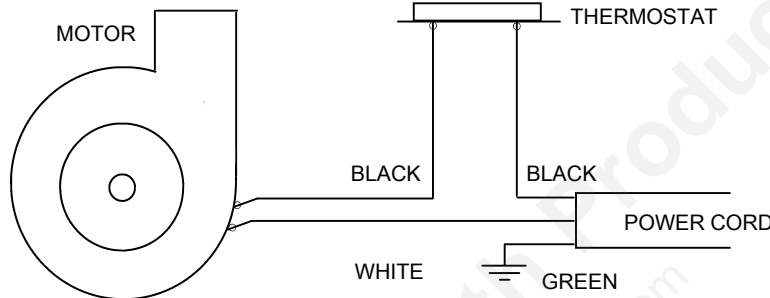

Maintenance.

Unit installed a prefabricated fireplace. To replace motor or thermostat without pulling stove from fireplace.

1. Open feed access door, clean all ashes and debris from inside fire box .
2. Remove fire brick from floor of inside fire box (some brick may need prying, try not to not damage the brick) lay brick aside.
3. Remove fire brick from inside back of fire box and lay brick aside.
4. Gently remove the fire blanket from inside back of fire box.
5. Remove plate inside back of fire box and a second fire blanket .
6. Remove a inner back plate by removing (8 eight) bolts (NOTE; you may need to spray WD-40 onto bolts) lay aside.
7. You access blower motor and thermostat through opening inside back of fire box.
8. After replacing parts, reverse the steps 1-7.

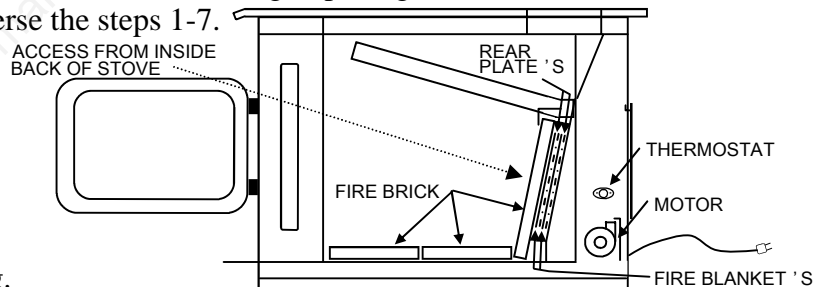
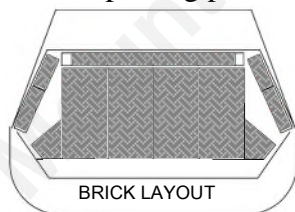

Unit installed as free standing.

1. At the back of unit there is a rear motor cover, remove the (2 two) screws at the bottom of the cover, slide down and lay rear motor cover aside.
2. You access blower motor and thermostat through opening in the back of the stove.
3. After replacing parts, reverse the step 1.

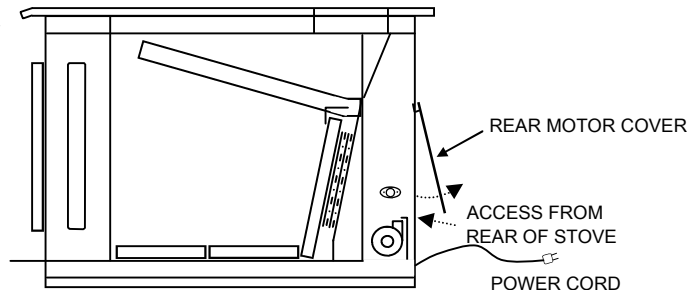

REPLACE OR TIGHTEN GASKET ON SIDE WINDOWS (COLD HEATER)

1. Open feed door.
2. On each side of inside door opening there are nuts holding glass overlays with side glasses to the stove. (2 two) nuts for each of glass overlays, one at the top and one at the bottom of each overlay.
3. Spray overlay nuts with WD-40 and wait awhile for the WD-40 to penetrate the threads. After letting WD-40 set, gently loosen glass overlay nuts. Work the nuts back and forth gently, you may have to use WD-40 again to get the nuts loose.
4. Remove the glass overlay. Take glass out of overlay and remove old gasket replace with new gasket.
5. Replace glass into overlay then place both the glass and overlay back onto the stove front.
6. Gently snug the nuts tight.
7. NOTE: Latter after several firings you may have to tighten the nuts more.

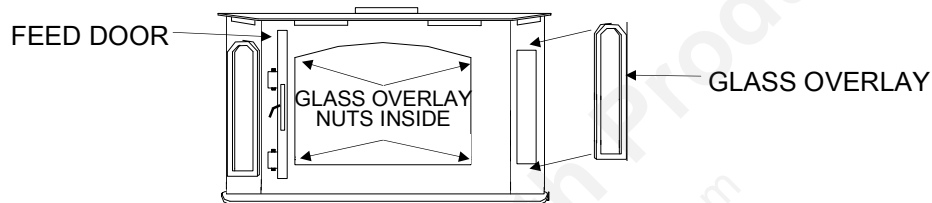

DOOR GASKET REPLACEMENT (COLD HEATER)

To replace deteriorated gaskets, following steps must be taken to ensure proper installation of gaskets.

1. Obtain proper gaskets and silicone glue from your local dealer.
2. Using pliers, remove any worn and deteriorated gaskets.
3. Using a scraper, wire brush and sandpaper or steel wool, clean glue and gasket residue from door frame.
4. Measure and cut gaskets to length. Care should be taken not to stretch gaskets. What you want is a full and loose gasket weave after attachment to framing.
5. Obtain silicone glue and run a 3/16" bead inside door frame.
6. Obtain gasket (s) and place in gasket channel areas starting at lower right corner, See Below. Use a technique which assures that gasket is applied in a loose like manner. **DO NOT STRETCH GASKETS.**
7. After gasket (s) are applied to glue, use your finger and go over all gasket gently pressing gasket to the channel. Use same pressure against gasket so that final result is an evenly applied gasket.
8. Leave door open and allow at least two (2) hours for glue to dry.
9. Once gaskets are checked, heater is ready for use.
10. This should be done annually. Allowing gaskets to deteriorate can cause over-firing and shorten burn time.

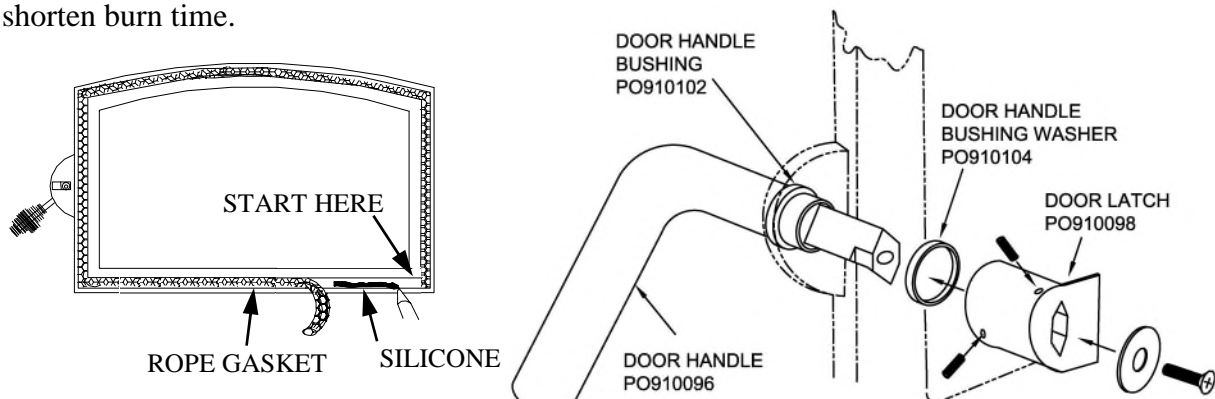

MAINTENANCE

CHECK CHIMNEY

- A. Chimney should be inspected twice a year.
- B. The chimney should be cleaned as necessary to remove creosote, soot, leaves, birds' nests, etc.

Before sweeping the chimney a few steps must be done.

1. Open feed door and remove the 1st Secondary Air Tube by removing cotter pin up in right side facing stove. Remove Air Tube and cotter pin, set aside.
2. Gently remove the Insulation Blanket set aside.
3. Remove Stainless Steel Baffle Plate set aside.
4. Close feed door for cleaning chimney so debris don't fall out feed door while cleaning chimney.
5. Creosote and debris will fall into the bottom of the stove unit from the cleaning.
6. Clean out all the creosote and debris from inside stove unit left from clean sweeping chimney.
7. To replace Stainless Steel Baffle Plate, Insulation Blanket and 1st Secondary Air Tube reverse steps 1-3

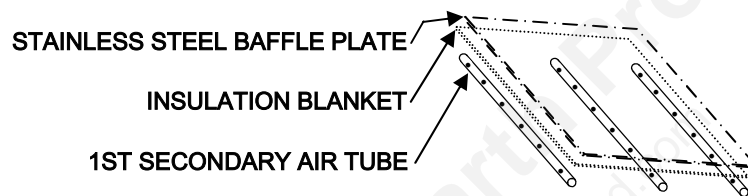

⚠ NOTE: A chimney cap should be installed to prevent moisture from entering chimney, to prevent sparks and burning materials from escaping chimney and to keep birds and foreign materials from entering.

*** NOTE:** Some areas may require an approved spark arrestor.

CLEANING THE HEATER

- A. The heater should not be cleaned with any type of detergent as most all detergents have an oil base and cannot be painted over.
- B. The heater should be lightly sanded with fine sandpaper or steel wool, then repainted or touched up with high temperature paint.
- C. If the heater is located in a moist or damp location, check thoroughly for signs of condensation during times when heater is not in use.
- D. When heating season is over, heater should be cleaned out completely with a wire brush or cloth to help eliminate ash and burned wood smell.

CARE OF GLASS DOOR

The glass door on your heater permits you to enjoy the beauty of the fire while retaining efficiency of your heater. Although brand of glass used in heater door has well established and recognized heat resistant and strength characteristics, it can be broken through improper care. To achieve maximum utility and safety of your glass door, we advise that you observe following use and safety tips:

1. Inspect glass regularly for cracks or breaks. If you detect a crack or break extinguish fire immediately and return door to your dealer for glass replacement before further use.
2. Do not slam heater door or otherwise impact glass. When closing door, make sure that no logs or other objects protrude to impact against glass.
3. Do not clean glass with materials which may scratch it (such as steel wool) or otherwise damage glass. Scratches on the glass can develop into cracks or breaks.

The glass can be cleaned with a commercial oven cleaner, providing it does not contain abrasives. A build-up on glass that has been there for a considerable length of time can be burned off with a propane torch or straight razor blade. Use protective gloves when using razor.

SECTION IX TROUBLESHOOTING

PROBLEM	POSSIBLE CAUSE	SOLUTION
Sluggish heater	Obstruction in chimney	Check for and remove obstruction
	Improperly sealed trim kit or direct connect kit	(a) Check trim kit gasket seal to fireplace and gasket as necessary to seal unit. Check gasket under front bottom of stove if needed. (b) Check seal if direct connect and correct
	Wet or unseasoned wood being burned	Burn dry natural seasoned hard wood
	Poor chimney draft	Improper chimney height or wrong size flue is being used. Cooler temperatures caused by external chimney

PROBLEM	POSSIBLE CAUSE	SOLUTION
High fuel consumption	Improper regulation of draft or inlet air	(a) Close inlet air control as much as possible to maintain desired heat output (b) Check gaskets, reinstall fiberglass gasketing around doors and glass as necessary
	Improper door fitting	Check door gasket, check adjustment of door latch, check door hinges
Backpuffing	Gusts of Wind	a) Smoke shelf in chimney is filled with creosote & ash b) Chimney may need wind diverter. Raise chimney for better draft
Smoke rollout when heater door is opened	Wind gusts blowing down the chimney	a) Smoke shelf in chimney is filled with creosote & ash b) Chimney may need wind diverter. Raise chimney for better draft
	Opening heater door too fast	Open air control, crack door for 15 seconds before fully opening door

REPLACEMENT PARTS FOR MODEL 18

Description	Part No.
1. Air Control Bar	MF 810084
2. Door Handle Assembly	PA 910096
3. Door Roping 3/4"	RP FR2LD.750G
4. Glass Gasket	RP FTV125X1.00GA
5. Inside Motor Plate Blanket	PO 180102
6. Outdoor Motor Plate Blanket	PO 180100
7. Door Gold	PC 212400G
8. Door Black	PC 212400
9. Thermostat 110 disc	PE 400132
10. Power Cord	PE 400240
11. Strain Relief	PE 400320
12. Motor - Non-cat	PE SBRO84
13. Firebrick	PR 900050
14. Glass	PG 2124GL
15. Glass, Bay side	PG 810100
16. Glass clip	PO 210767
17. 1/4" plain washer-pltd.	PH 14FLWSP
18. Cotter Pin	PH 182CPSS
19. Door Hinges	PH 516HINGE
20. 5/16" LK washer-gr5	PH 516LKWS5
21. Spring Handle	PO 100150
22. "U" Drive Screw 5/16" x 1/2"	PO 516U
23. Top Firebox Blanket	PO 180110
24. Mid & Rear Secondary Air Tube	PO 180106
25. Front Secondary Air Tube	PO 180104
26. Hearth Brass	PO 810705
27. Primary Air Block	MF 180084
27. Side Brass Overlay	PO 810104
28. Top Baffle Plate	PS 180032

For replacement parts use only manufacturer's specified parts.

NEW BUCK CORPORATION (NBC)
"LIMITED WARRANTY" FOR THE BUCK STOVE
PLEASE READ THIS WARRANTY CAREFULLY

PRODUCTS COVERED

This warranty covers the new Buck Stove heating unit, so long as it is owned by original purchaser, including optional and standard accessories purchased at same time, subject to terms, limitations, and conditions herein set out.

PRODUCTS NOT COVERED

This warranty does not cover the following:

Glass, Refractory material or firebrick, Gaskets.

This warranty will not cover any damage and/or failure caused by abuse or improper installation of the products covered.

WARRANTY TIME PERIODS

(A) Period I

For one (1) year from date of purchase, NBC will replace or repair, at its option, any part defective in materials or workmanship. The costs of parts only are included. The customer pays any labor or transportation charges required.

Thereafter

(B) Period II

For a period after first year from date of purchase and extending for five (5) years as long as the Buck Stove is owned by original purchaser, NBC will repair or replace, at its option, any part defective in materials or workmanship, with the exception of: electrical motors, wiring, switches, and components: optional and standard accessories. All parts not permanently attached to the heating unit. Parts not permanently attached to heating unit are defined as those items designed to be removed from stove, including those removable with common hand tools. The costs of parts only are included. The customer pays any labor or transportation charges required.

PROCEDURE

Should you feel that your BUCK STOVE is defective, you should contact any Buck Stove dealer for name of your nearest authorized Buck Stove service representative, who will instruct you on the proper procedure, depending on which Warranty Time Period (Period I or Period II) applies.

If for any reason you are dissatisfied with the suggested procedures, you may contact us in writing at:

New Buck Corporation
P. O. Box 69
Spruce Pine, NC 28777

CONDITIONS AND EXCLUSIONS

- A. Replacement of parts may be in form of new or fully reconditioned parts, at NBC's option.
- B. There is no other express warranty. All implied warranties of merchantability and fitness for use are limited to the duration of Express Warranty.
- C. New Buck Corporation is not liable for indirect, incidental or consequential damages in connection with use of the product including any cost or expense of providing substitute equipment or service during periods of malfunction or non-use.
Some states do not allow exclusion of incidental or consequential damages, so above exclusion may not apply to you.
- D. All warranty repairs under this warranty must be performed by an authorized Buck Stove service representative. Repairs or attempted repairs by anyone other than an authorized service representative are not covered under this warranty. In addition, these unauthorized repairs may result in additional malfunctions, correction of which is not covered by warranty.

OTHER RIGHTS

This warranty gives you specific legal rights, and you may also have other rights, which vary from state to state.

OWNER REGISTRATION CARD

The attached Owner Registration Card must be completed in its entirety and mailed within 30 days from date of purchase or from date of installation, if installed by a factory certified installer, to New Buck Corporation in order for warranty coverage to begin.

PLEASE NOTE: The Owner Registration Card must contain Authorized Buck Stove Dealer Code Number and Certified Installer's number (if applicable) for warranty coverage to begin.

To be completed by selling distributor or dealer for customer:

Name: _____		
(Last)	(First)	
Address: _____		
City: _____	State: _____	Zip: _____
Customer Email: _____		
Model 18 _____	Serial Number _____	
Date of Installation: Day _____	Month _____	Year _____
Installer's Name: _____		
Installer's Certification Number: _____		
Dealer's Name and Address _____		