

**BUCK
STOVE** [®]
unmatched [™]
Your Energy Answer [™]

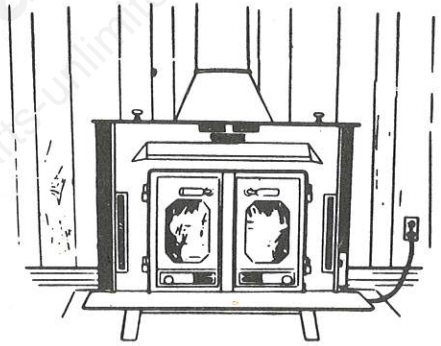
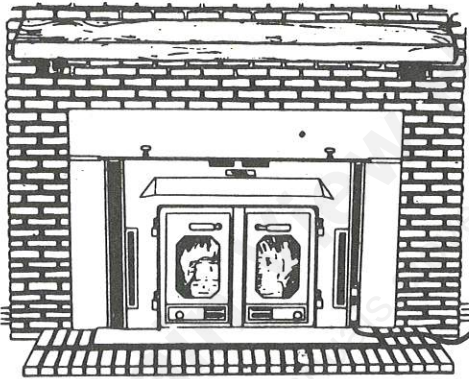

INSTRUCTION FREESTANDING, MASONRY INSERT, AND BUCKMATE INSERT

MODEL 26000-B

MODEL 27000-B

MODEL 28000 (Not UL Listed)

Contact local building and/or
fire officials about restrictions and
installation inspection in your area.

FEATURES

INSTALLATION

MAINTENANCE

PREPARATION

OPERATION

SAFETY



This symbol on the nameplate means the product is Listed by Underwriters Laboratories, Inc. (UL Standard No. 737
Fireplace Stoves) File No. MH11032.

**SMM-01-001-A5
SMM-01-002-A5
EFFECTIVE 5/1/85**

DEAR CUSTOMER,

WELCOME to the **BUCK STOVE** family! You have probably noticed that most owner's manuals begin by offering congratulations. We want to reserve that courtesy for you. You see, we are convinced, that after you have used the **BUCK STOVE** even for a short time, that you will want to congratulate yourself for making such a wise buying decision.

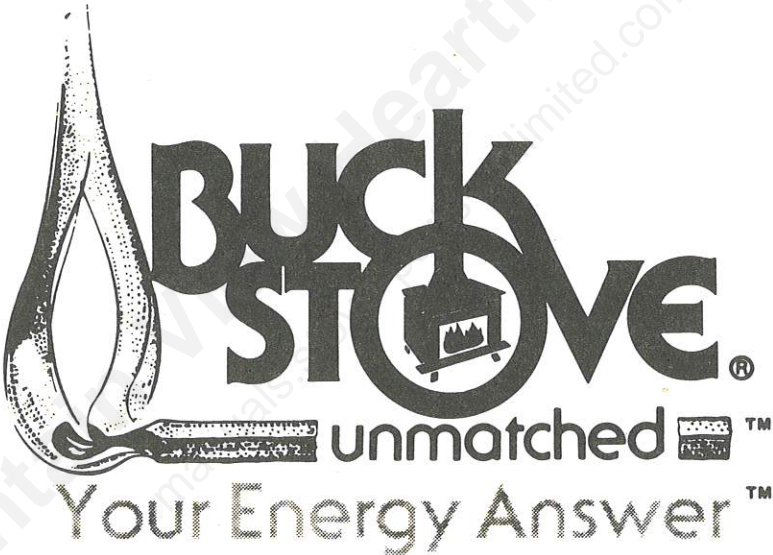

BUCK STOVE customers are urged to use this manual. The contents of this manual provides information on safety of stove operation and heating efficiency. By following the instructions and suggestions outlined, you can ensure years of safe, economical heat for yourself and your family. It will also help you get a good return on your investment.

WELCOME again to the family of **BUCK STOVE** owners!

SAFETY NOTICE

If this stove is not properly installed, a house fire may result. For your safety, follow the installation directions. Contact local building or fire officials about restrictions and installation inspection requirements in your area.

TABLE OF CONTENTS

INTRODUCTION	Inside Cover
BUCK STOVE FEATURES	2
SECTION I - MASONRY INSERT INSTALLATION	4
MINIMUM CLEARANCES	5
REQUIRED FIREPLACE DIMENSIONS	6
TOOLS FOR INSTALLATION	6
INSTALLATION PREPARATION	7
POSITIONING THE BUCK STOVE	7
MOUNTING THE TRIM PANELS	7
SEALING THE TRIM PANELS	11
FINAL STEP	11
FINAL CHECK	12
SECTION II - FREE-STANDING INSTALLATION	13
MINIMUM CLEARANCES	14
TOOLS FOR INSTALLATION	16
INSTALLATION PREPARATION	16
DETERMINING THE CHIMNEY LOCATION	17
FINAL CHECK	18
SECTION III - BUCKMATE INSERT INSTALLATION	21
PARTS REQUIREMENTS	23
PREPARATION AND CONSTRUCTION	24
ZC-2-01/26000-B LITTLE INSTRUCTIONS	26
ZC-3-01/27000-B REGULAR INSTRUCTIONS	30
ELECTRICAL INSTALLATION	36
FINISHING	37
STACK INSTALLATION	38
SECTION IV - SAFETY	41
WOOD STOVE SAFETY	42
SAFETY PRECAUTIONS	42
SECTION V - OPERATION	43
BUILDING A FIRE	44
GUIDE TO THE BURNING QUALITIES OF WOOD	45
COAL BURNING	46
HELPFUL HINTS	47
SECTION VI - MANUFACTURER'S SUGGESTED PREVENTIVE MAINTENANCE	48
CHIMNEY	49
STOVE	49
CLEANING THE STOVE	49
GLASS DOORS	49
CREOSOTE - Formation and Need for Removal	50
WARRANTY	Back Cover

The BUCK STOVE Models 26000-B, 27000-B, and 28000 are safe and efficient heating systems which utilize either wood or Bituminous coal as fuel.

The installation and operating instructions found in this manual have been developed through extensive laboratory testing and in the field experience. The procedures outlined MUST be followed exactly to ensure a safe and operational installation as well as to validate your warranty.

Throughout the manual you will see this symbol  This indicates areas of importance regarding safety. Please make a special note of these areas. Read these instructions carefully before installing your BUCK STOVE and keep them with your important papers for future reference.

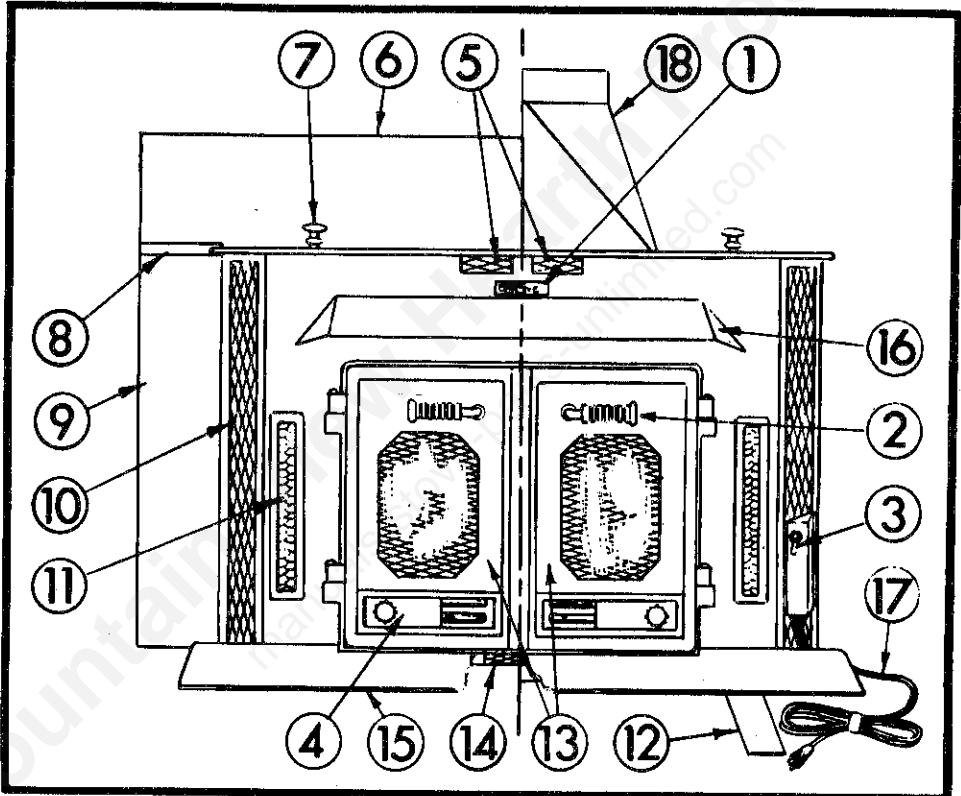

FIGURE 1

PHYSICAL FEATURES

INSTALL AND USE ONLY IN ACCORDANCE WITH THE MANUFACTURER'S INSTALLATION AND OPERATING INSTRUCTIONS. DO NOT CONNECT THIS UNIT TO A CHIMNEY FLUE SERVING ANOTHER APPLIANCE.

BUCK STOVE FEATURES

Before attempting to install or operate your **BUCK STOVE**, it is a good idea to familiarize yourself with the features and operating controls of the stove. (Figure 1)

OPERATING CONTROLS

1. **DAMPER:** The damper control is located in the center of the stove, just under the stove top. It is operated by lifting up on the control handle, and then pushing or pulling the handle. When the handle is lowered, the control locks into position. The damper is fully open when the control is pushed in, and fully closed when the handle is pulled out. The damper must be opened before the doors are opened.

2. **DOOR HANDLES:** The door handles on the **BUCK STOVE** are air cooled and shielded. The handle on the right hand door latches the doors shut, while the left hand handle is fixed. To open the doors, rotate the right handle up, or counter clockwise one quarter turn, and pull the doors open. The doors are closed and locked by reversing the procedure.

3. **BLOWER CONTROL:** The blower control switch is located on the lower right side of the stove front. This switch controls the functioning of the built in fan. In the "MANUAL" position, the blower operates continuously; in the "AUTOMATIC" position, the blower is controlled by an internal thermostat in the stove which reacts to the temperature of the air between the stove walls. The speed of the blower is then dependent primarily on the size of the fire in the firebox.



CAUTION! DO NOT unplug the blower during stove operation!

4. **DRAFT CONTROLS:** The primary air draft controls are located on the lower portion of the doors. They are operated by sliding the controls to uncover more or less of the draft air inlets. A knob is provided which is used to operate the control and also serves a locking function. The control is locked into position by screwing it in until it is snug.

5. **UPPER WARM AIR OUTLET:** Provides heat extraction from the top surface of the stove.

6. **UPPER TRIM PANEL:** Seals the fireplace against soot and ash, and prevents warm room air from escaping up the chimney on masonry insert.

7. **DECORATIVE BRASS KNOBS:** Adds an attractive accent to the stove's appearance.

8. **GOLD TRIM:** Same as brass knobs for masonry insert.

9. **SIDE TRIM PANEL (2):** Same as top trim panel for masonry insert.

10. **AIR INLET:** Allows cooler room air to be circulated through the blower and back into the warm air chamber of the stove.

11. **SIDE WARM AIR OUTLET (2):** Extracts heat from the sides of the firebox.

12. **STAND:** Elevates free standing stove for safety and a beautiful appearance.

13. **DOORS:** Provides an "airtight" feature. The doors allow a much higher burning efficiency than can be obtained with an open firebox.

14. **LOWER WARM AIR VENT:** Extracts heat from the bottom of the firebox. It is a primary part of the patented air flow pattern of the **BUCK STOVE**.

15. **HEARTH PLATE:** Offers protection from spilling ashes and cinders on the fireplace hearth. It also separates the warm air outlet from the primary draft air.

16. **SMOKE HOOD OR VISOR:** Helps trap any smoke which escapes when the doors are opened too rapidly. After the doors are opened, the natural draft of the stove will pull the smoke back inside.

17. **POWER CORD:** Provides electrical power to operate the blower.

18. **STACK:** Chimney connector for free standing stove.

SECTION I

MASONRY INSERT INSTALLATION

26000-B

27000-B

28000

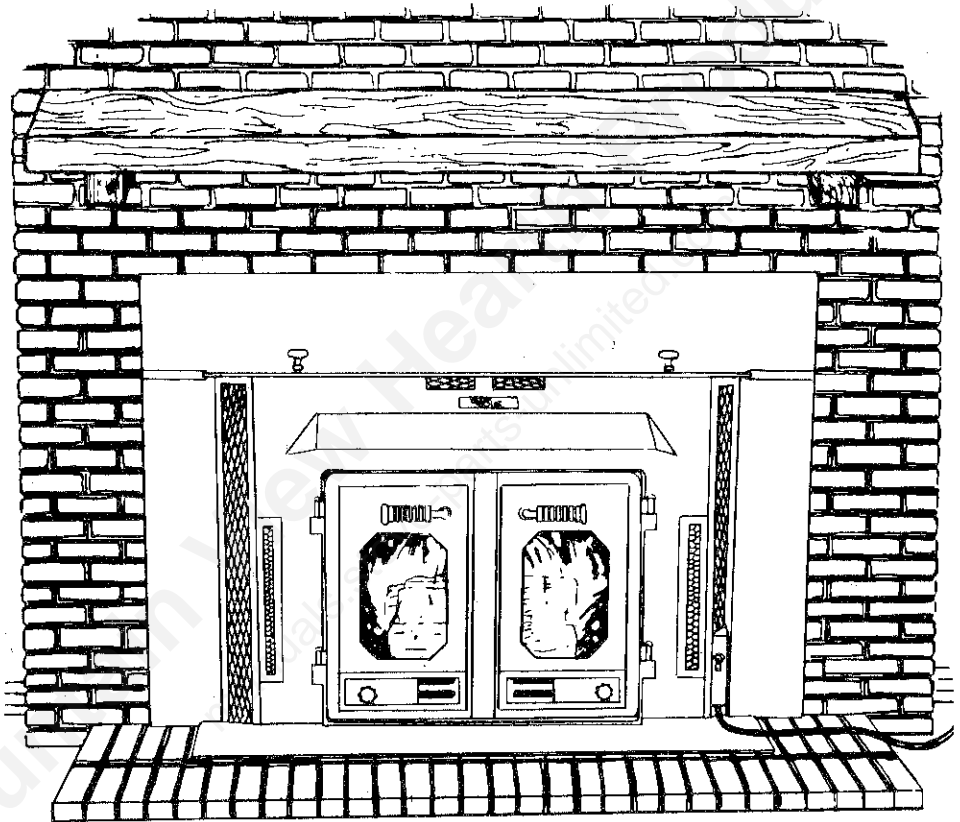

When the **Buck Stove** is to be installed as an insert, the appropriate kit must be used.

FP26 for Little Buck 26000-B

FP27-B for Regular Buck 27000-B

FP28 for Big Buck 28000

SECTION I: INSTALLATION

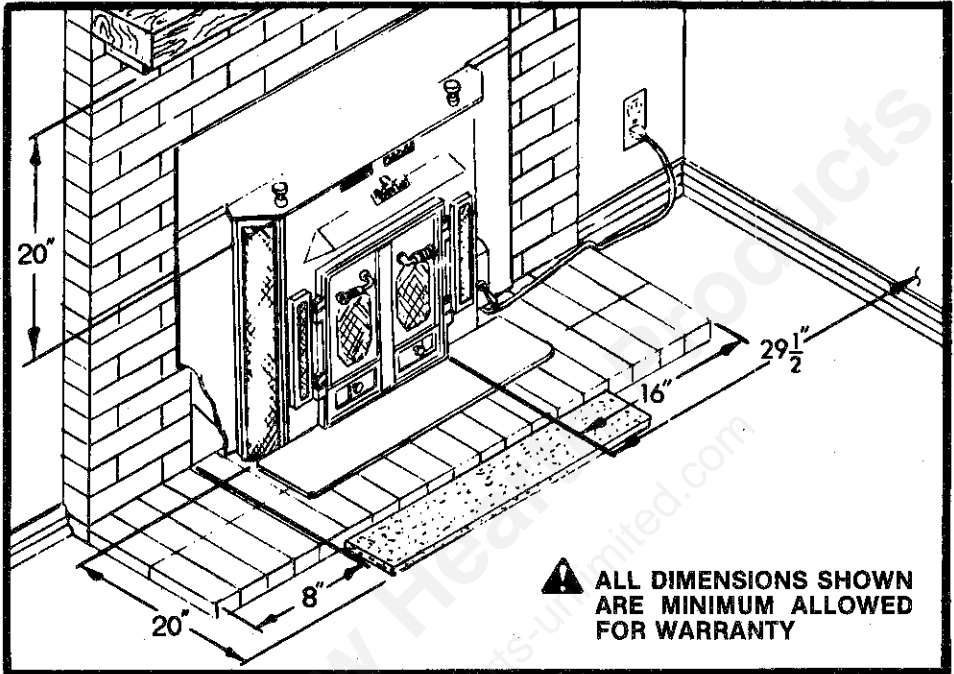

FIGURE 1

INSTALLED MINIMUM CLEARANCES

Minimum Clearances:

The BUCK STOVE Models 26000-B, 27000-B, and 28000 are intended for installation in accordance with the standard chimneys, fireplaces, vents, and solid-fuel burning appliances, NFPA-211 code. The applicable parts of this code are:

1. The chimney must be of masonry construction with an open cross-sectional area of at least 50 square inches (7- $\frac{1}{4}$ " x 7- $\frac{1}{4}$ " square or 8" round.)
2. The hearth must be of masonry construction and must extend a minimum of 16" in front of the fireplace opening and a minimum of 8" to either side of the fireplace opening.
3. There must be a minimum of 8" between the side of the masonry fireplace opening and any combustible materials, or 16" between the **BUCK STOVE** firebox opening and any combustible materials. If there is not 20" from the front of the **BUCK STOVE** firebox opening and the front of the masonry hearth, a floor protector must be used in front of the hearth to protect combustible materials. The floor protector is to be of non-combustible, inorganic material equal to 3/8" thick millboard having a thermal conductivity of $K = 0.84 \text{ BTU/F}^2\text{H}^{\circ}\text{F inches}$ and must measure 38" wide. The minimum clearances for the fireplace model are shown in Figure 1.
4. If your fireplace has wood trim above it, or a wood mantel, it must be located so there is at least 20" between the top of the **BUCK STOVE** and any part of the trim or mantel including supports. This can be reduced to 18" (See Figure 2) if a modified trim kit is used (examples shown in Figure 8, Page 9 and Bending Modification Tip for Modified Trim Kit Page 10.)

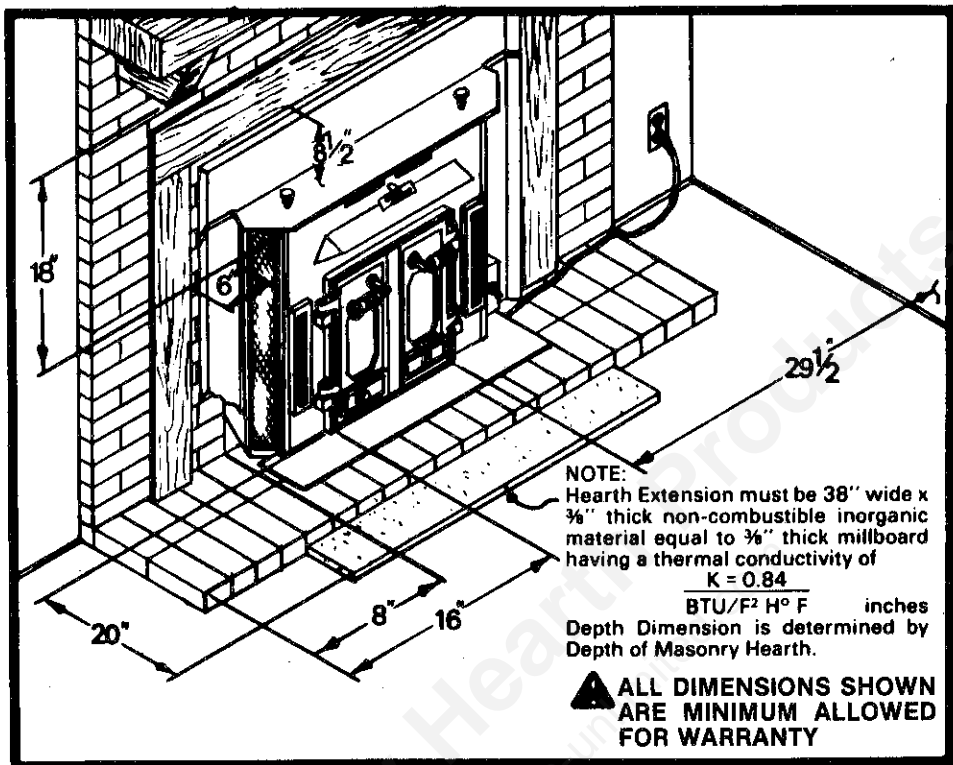

FIGURE 2

INSTALLED MINIMUM CLEARANCES TO WOOD TRIM WITH MODIFIED TRIM KIT

REQUIRED FIREPLACE DIMENSIONS

The minimum and/or maximum fireplace dimensions for the installation of a **BUCK STOVE** are:

FIREPLACE MODEL	HEIGHT	WIDTH	DEPTH (MIN)
26000-B Little Buck	22 1/4"-29"	30-40"	17"
27000-B Regular Buck	24 1/4"-31"	34-44"	17"
28000 Big Buck	26 1/4"-33"	37-47"	17"

TOOLS FOR INSTALLATION

If you decide to install your own stove, there are several hand tools you will need to do the job. If you do not already have them, they are readily available at most hardware stores.

- Hack saw
- Caulking gun
- Large adjustable wrench (may not be needed)
- Drop cloths or newspapers
- Vacuum cleaner or whisk broom
- Flashlight
- 1 tube of RTV silicone. Code 103 or 106, or high temperature rubber cement rated between 450°-600°F.
- 7/32" drill bit and drill

INSTALLATION PREPARATION

Fireplace

1. Locate furniture and other materials away from the front of the fireplace to allow free access to the fireplace.
2. Cover the hearth and adjacent floor areas with the drop cloths to protect from soiling or marring the surfaces.
3. Remove the existing fireplace damper plate.
4. Thoroughly clean the fireplace of ashes and soot.
5. Check the chimney and smoke chamber for excessive buildups of creosote or soot. Also, check for obstructions, such as birds' nest. If the chimney is excessively dirty, clean it, or have someone clean it professionally **BEFORE** installing or using the **BUCK STOVE!**

Stove Preparation

1. Remove the protective plastic wrapping from the stove.
2. Inspect the stove for any obvious physical damage.
3. Plug the power cord into a 115 VAC outlet to test the motor and fan. Place the blower control in the "MANUAL" position to test.
4. Check the primary air draft controls to ensure that they slide freely and will lock into position when the control knobs are tightened.
5. Check the operation of the damper control to ensure that it will open and close properly.
6. Open and remove the doors and firedogs from the stove to facilitate installation.

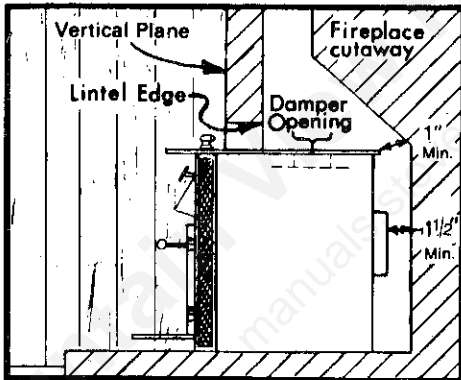

FIGURE 3 STOVE POSITIONING

POSITIONING THE BUCK STOVE

When positioning the stove, the following conditions **MUST** be met! (See Figure 3)

1. The front of the damper opening must be positioned **BEHIND** the rear edge of the lintel to ensure proper draft. (See Figure 3)
2. The vertical plane of the fireplace front must fall **BEHIND** the side cold air vent on top of the stove. (In other words, it is possible to have the stove too far in as well as not far enough!)
3. Center the stove in the fireplace opening.

MOUNTING THE TRIM PANELS

After the **BUCK STOVE** is positioned, as shown in Figure 3, mark the mounting position of the trim panels as follows:

1. Set the top (long) trim panel in place on top of the stove. The panel should be flat against the outside face of the fireplace, and standing vertically. Mark along the lower edge of the trim panel with a pencil to make a reference line for mounting.
2. Set the side trim panels in place, again flat against the outside face of the fireplace. Mark down the inside edge of the trim panel to make a vertical reference line.
3. Slide the **BUCK STOVE** out of the fireplace far enough to work behind the trim panel reference lines.

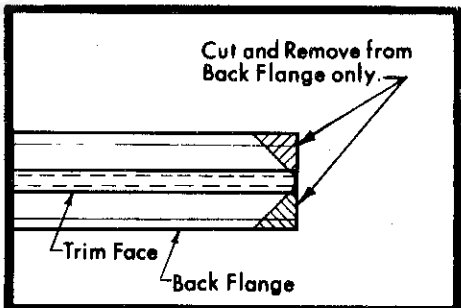

FIGURE 4 PREPARING GOLD TRIM

4. Mount the side trim panels. (See Figure 5)
 - a. Position the trim panel on the reference line.
 - b. Drill Mounting Holes in center of trim panels mounting brackets to allow for adjustment in and out if necessary.
 - c. Mount the trim panel using the self-tapping screw provided.

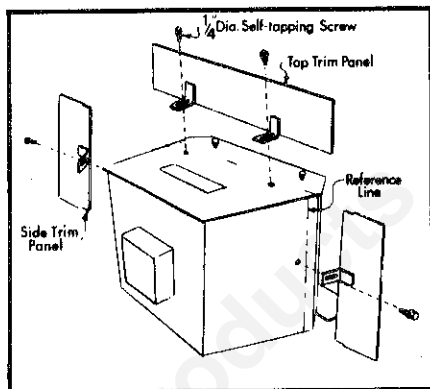

FIGURE 5 MOUNTING TRIM PANEL

5. Ends of gold trim should be prepared for easier insertion to touch stove top in side and top trim panels. (See Figure 4)

6. Mount top trim panel and insert gold trim. If they overhang on each side trim panels, they should be marked and cut off for neater appearance. Gold trim can also be cut in this step.

(See Figure 6)

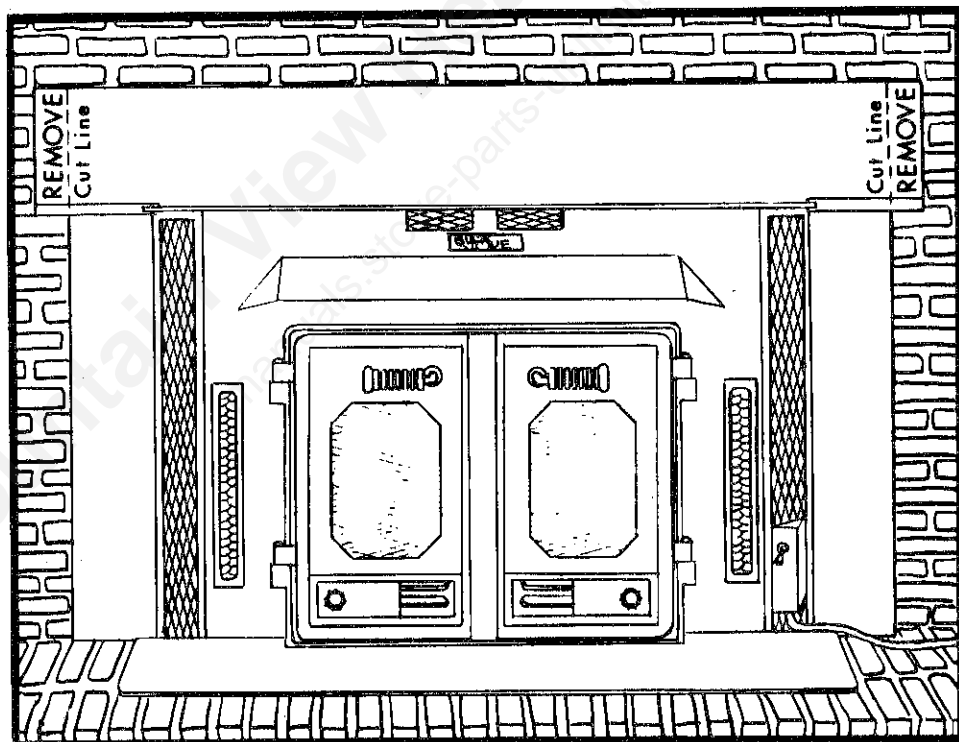

FIGURE 6

MARKING TOP TRIM

7. Set the top trim panel in place and mount the same as the side panels.

8. Slide the **BUCK STOVE** back into the fireplace. Check to be sure that the trim panels are properly positioned and lie flat against the front of the fireplace. If one or more of the panels is out of position, slide the stove out and reset by loosening the mounting screws and repositioning in the slot. (See Figure 7)

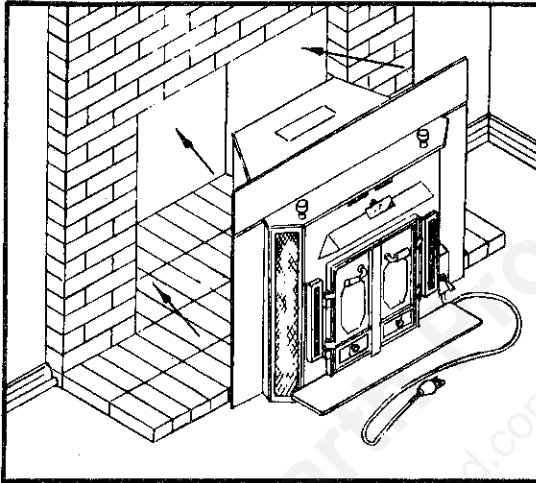

FIGURE 7

CHECKING TRIM
PANEL ADJUSTMENT

MINIMUM CLEARANCE FOR BUCK STOVE FIREPLACE INSERTS MODIFIED TRIM KIT.

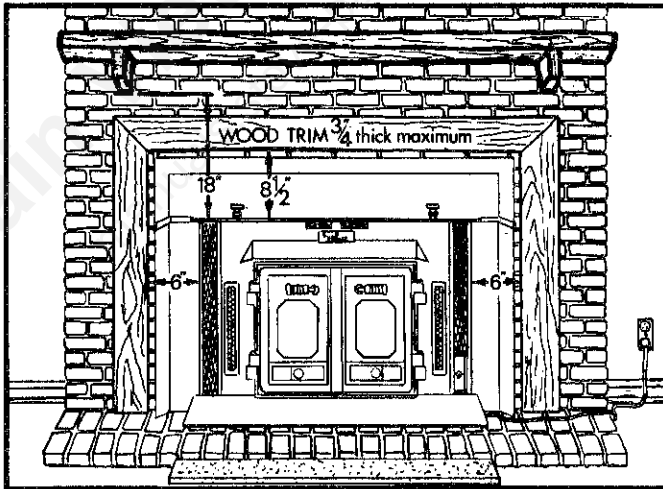
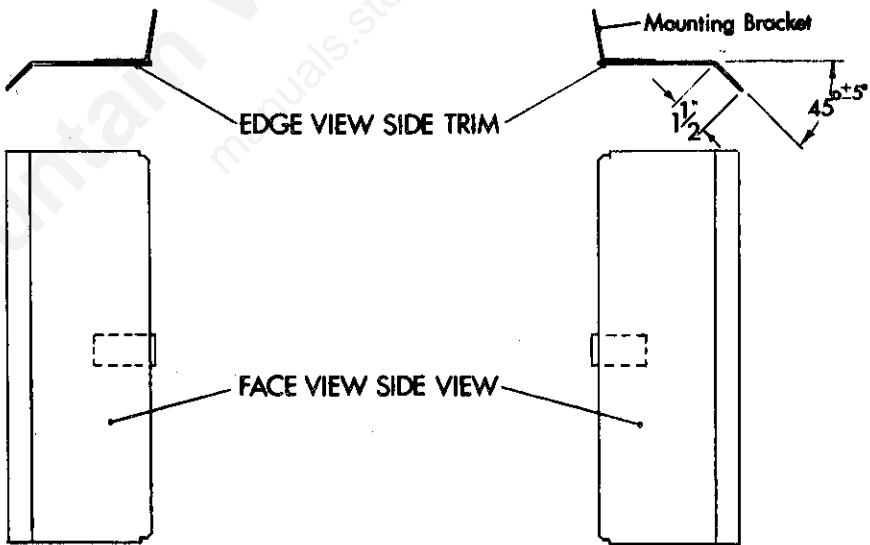
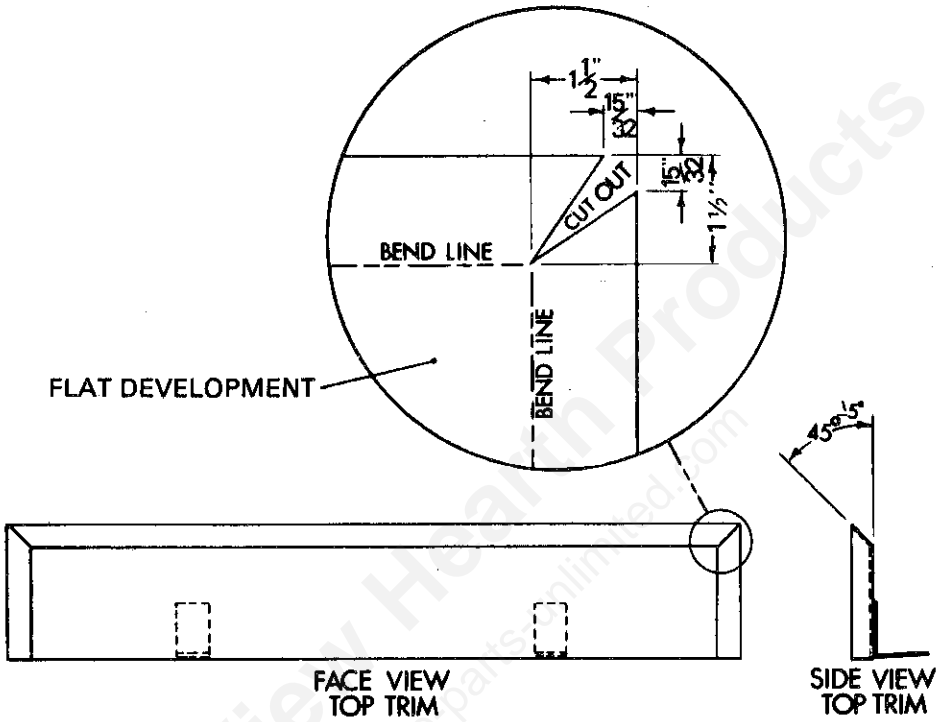

FIGURE 8

INSTALLED MINIMUM CLEARANCES

Figure 8 shows a Buck Stove Fireplace Insert with a modified trim kit, installed in a masonry fireplace showing minimum clearances for Georgian or Colonial type wood trim, on a masonry fireplace. If wood trim is desired around the fireplace front, modify the trim kit as shown in the bending modification tip on the following page. With modification on the stove trim kit, there must be a minimum of 6" from the cold air intake to side wood trim, and 8 1/2" from stove top to top wood trim. Wood trim should not exceed 3/4" thick.

BENDING MODIFICATION TIPS FOR MODIFIED TRIM KIT



SEALING THE TRIM PANELS

It is necessary to seal trim panels against the stove and against the fireplace front. This will prevent the loss of warm room air up the chimney.

1. (See Figure 9) Using the caulking gun and a cartridge of RTV silicone, run a bead of silicone all the way around the inside of the trim panels next to the stove.

2. (See Figure 10) Attach 1½" x 2" strip insulation around the back edge of the trim panels. Set the strip back 1" from the edge.

NOTE: On rock face fireplaces, it may be necessary to add additional pieces of fiberglass to fill large or deep or mortar joints.

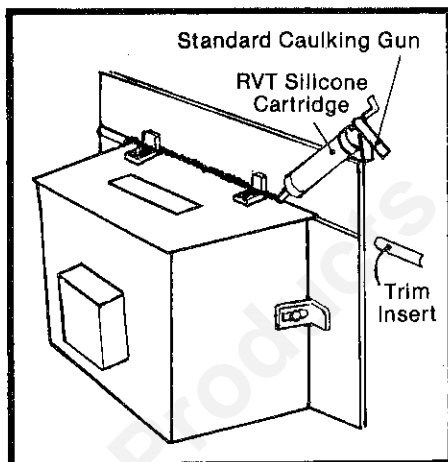

FIGURE 9 SEALING TRIM PANELS

FINAL STEP

1. Slide the stove back into the fireplace. Be sure the trim panels all fit snugly against the face of the fireplace. **NOTE:** Be sure the top edge of the trim panel runs true with the mortar joints on a brick fireplace. If it does not, one side of the stove can be shimmed from the bottom with metal to give a "square" appearance.

2. Place a flashlight up through the damper and onto the top of the stove. Visually check all the way around the trim panels for evidence of light seepage. Any seepage should be blocked with the use of additional fiberglass and RTV silicone until a tight seal is achieved. (See Figure 10)

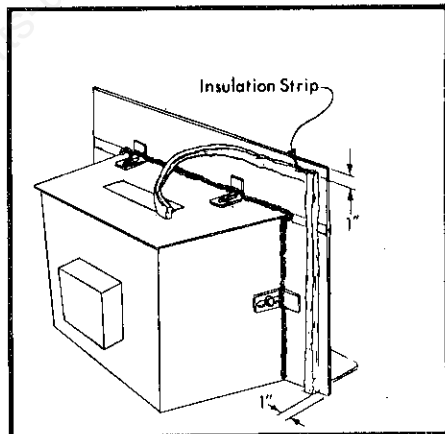

FIGURE 10 ATTACHING INSULATING STRIPS

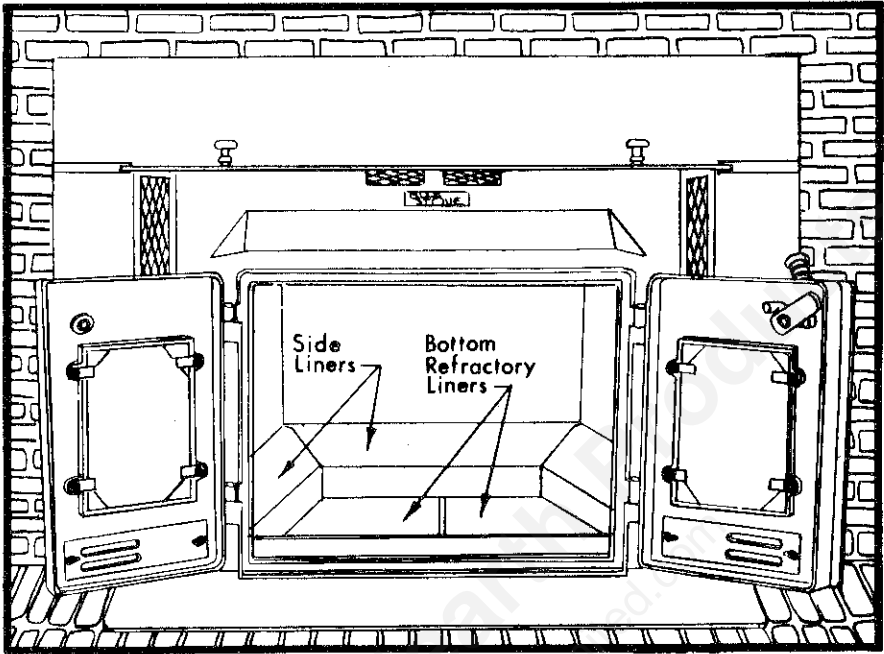

FIGURE 11

FINISHED VIEW

3. Install the firedogs (or coal grate, refer to Page 46), and replace the doors.

Note: Model 28000 is standard with bottom refractory only. Rear and side refractory can be purchased separately and must be used when burning coal.

FINAL CHECK

1. Recheck the specified clearances.
2. Remove all foreign material from the firebox area.
3. Open the primary air drafts and damper.
4. Plug the power cord into a 115 VAC outlet. **DO NOT** route the cord under the hearth plate or in front of the stove to the opposite side.
5. Place a crumpled piece of newspaper in the stove. Light it and close the doors. Ensure that the stove draws properly through the primary drafts. The paper should burn quickly and with a pronounced roaring sound.
6. Check for smoke leaks around the doors.
7. Open the doors and install the firescreen. Check for smoke escaping from the front of the stove. Smoking usually indicates a defective or poorly positioned chimney. If a thorough review of the installation instruction does not reveal the problem, contact your **BUCK STOVE** dealer for assistance.

NOTE: The **BUCK STOVE** is painted with a specially formulated temperature paint that cures during the first two or three firings. You may notice a slight smoking effect and an odor of burning paint when you build the first fires. This is normal and is not a cause for alarm. In some cases, these fumes will activate a smoke alarm. Cracking a window near the stove will allow these fumes to escape. **DO NOT** build a large, roaring fire until this curing is complete or the stove finish may be damaged.

SECTION II

FREE-STANDING INSTALLATION

26000-B

27000-B

28000

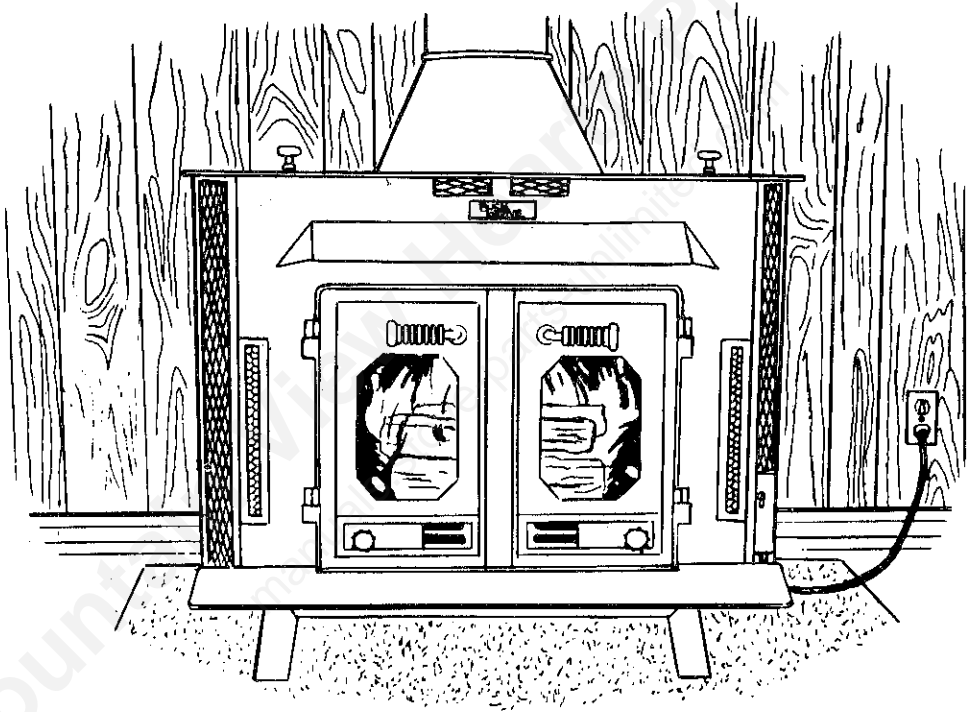

When a BUCK STOVE is to be installed as freestanding fireplace stove, kits No. L1 and S1 must be used.

SECTION II

MINIMUM CLEARANCES

The **BUCK STOVE** Models 26000-B and 27000-B must be installed in compliance with the instructions contained in this manual.

Clearance from combustible walls and ceilings.

The minimum lateral distance between any part of the **BUCK STOVE** models 26000-B and 27000-B are shown in figures 1 and 2.

Floor Protection

If a freestanding model of the **BUCK STOVE** is to be installed on a combustible floor, a noncombustible pad must be placed below it to protect the floor from radiant heat and burning material from the stove.

The pad must meet the following minimum specifications:

Use a Listed Floor Protector or a Floor Protector made of a non-combustible inorganic material equal to 3/8" Thk. millboard having a thermal conductivity of $K = 0.84$ BTU in.

Ft.₂H. Degrees F.

CHART A BUCK STOVE MODEL:

26000-B
27000-B
28000

Floor Protector MINIMUM SIZE:

48" X 48" X 3/8"
53" X 48" X 3/8"
54" X 54" X 3/8"

The **BUCK STOVE** must be positioned on the pad so that there is a minimum of 16" from the front edge of the hearth to the front of the pad, and a minimum of 8" measured diagonally from the sides of the stove to the sides of the pad.

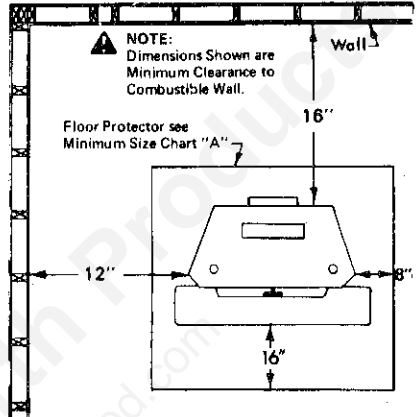

FIGURE 1 WALL INSTALLATION

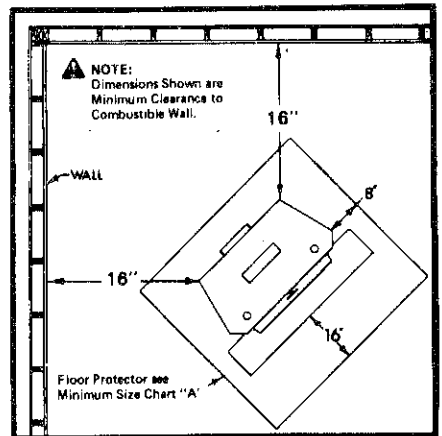

FIGURE 2 CORNER INSTALLATION

MINIMUM CLEARANCES

The BUCK STOVE Model 28000

The **BUCK STOVE** Model 28000 (**NOT UL LISTED**) must be installed in compliance with the instructions contained in this manual.

The minimum lateral distance between any part of the 28000 and a combustible wall is 36". (See Figures 3 & 4)

Floor Protection

If a freestanding model of the **BUCK STOVE** is to be installed on a combustible floor, a non-combustible pad must be placed below it to protect the floor from the radiant heat and burning material from the stove.

Use a Listed Floor Protector or a Floor Protector made of a non-combustible inorganic material equal to 3/8" Thk. millboard having a thermal conductivity of $K=0.84$ BTU in. (See Page 14)

Ft.,H. Degrees F.

With Wall Protector

Refer to NFPA—211-1980, (b), except that the **MINIMUM DISTANCE TO A PROTECTED WALL SHALL BE 18"**.

"UNLISTED PRODUCTS MUST BE INSTALLED WITH THE ACCEPTANCE OF THE AUTHORITY HAVING JURISDICTION AND IN ACCORDANCE WITH THE MANUFACTURER'S INSTRUCTIONS".

The **BUCK STOVE** must be positioned on the pad so there is a minimum of 16" from the front of the stove to the front of the pad and a minimum of 8" from the side of the firebox opening and the side of the pad.

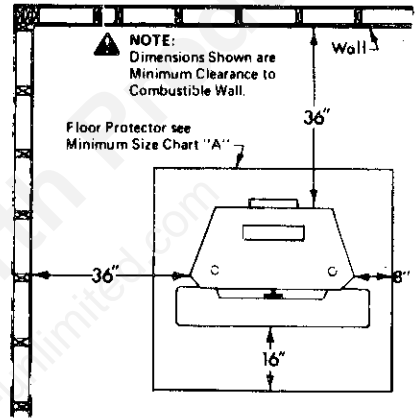

FIGURE 3 WALL INSTALLATION

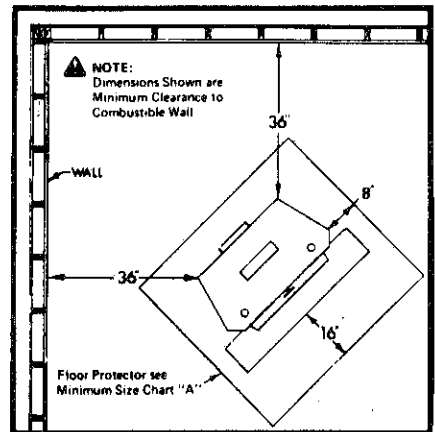

FIGURE 4 CORNER INSTALLATION

Chimney

The **BUCK STOVE** Models 26000-B and 27000-B are designed for connection to either an 8" inside diameter Underwriters' Laboratories, Inc. listed all-fuel residential type and Building Heating Appliance Chimney, or to a masonry chimney which meets the specifications of the National Fire Protection Association's 211 Code and has a minimum cross section area of 50 square inches ($7\frac{1}{4} \times 7\frac{1}{4}$ " or 8" round).

TOOLS FOR INSTALLATION

$\frac{1}{2}$ " - 9/16" combination wrench

7/32" drill bit and drill

$\frac{3}{8}$ " magnetic socket chuck adapter, $\frac{3}{8}$ " wrench (box or socket) or adjustable wrench.

PREPARING THE STOVE FOR INSTALLATION

1. Remove the protective plastic wrapping from the stove.
2. Inspect the stove for any obvious physical damage.
3. Plug the power cord into a 115 VAC outlet to test the motor and fan. Place the blower control in the "MANUAL" position to test.
4. Check the primary air draft controls to ensure that they slide freely and will lock into position when the control knobs are tightened.
5. Check the operation of the damper control to ensure that it will open and close properly.

STOVE MODEL	"A" Dimension
26000-B Little	Flush to Front
27000-B Regular 28000 Big	1 $\frac{1}{4}$ "

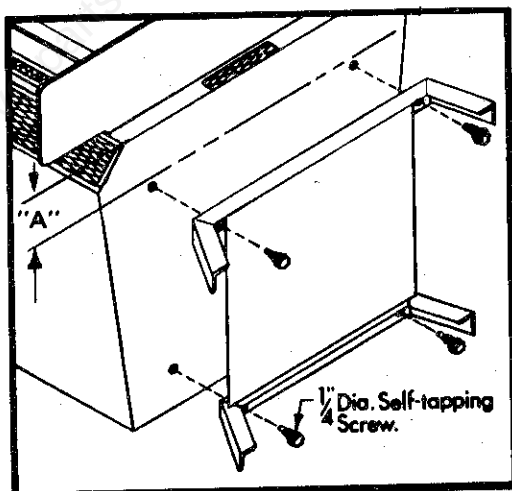

FIGURE 5

STAND MOUNTING

6. Open and remove the doors, firedogs, side liners and the cast refractory material from the bottom of the stove to facilitate installation.
7. Attach the legstand by tilting the stove on its back, center the legstand on the bottom of the stove and position back 7/32" from the dimension shown in chart left of Figure 5. When positioned, drill holes through holes of mounting stand and attach using $\frac{1}{4}$ " Dia. self-tapping screws provided. (See Figure 5.)

8. Attach the stack by placing the stack brackets down on the lip on the inside lower edge of the stack. Insert the bolts through the holes in the damper brackets and fasten securely with the lock washers and nuts provided. Be sure the stack sits squarely on the top of the stove with the gasket material making a good seal. (See Figure 6.)

PREPARING THE BUCK STOVE LOCATION

1. Select an installation location that will give the best airflow from the front of the stove to the remainder of the home.
2. Place the protective floor pad in position.
3. Place the stove on the pad making sure the minimum clearance specifications are met. (See Figures 1 through 4)
4. Install the cast refractory bottoms and the side liners.
5. Install the firedogs (or coal grate) and replace the doors.
6. In connecting to an existing masonry flue, first ensure that the flue conforms to the NFPA-211 Code. (Refer to Page 5) and/or consult your local code for proper procedure.

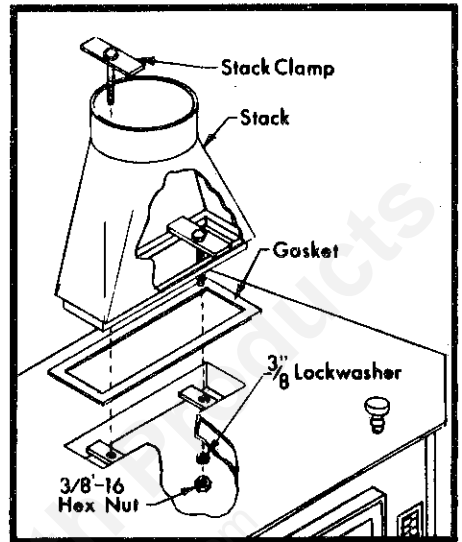

FIGURE 6 MOUNTING STACK

DETERMINING THE CHIMNEY LOCATION

1. Ceiling penetration

Suspend a plumb bob from the ceiling above the stove so that the weight is hanging in the center of the stack. (A small weight on a string will serve as a plumb bob.) Mark the ceiling where the string is suspended to locate the center of the chimney hole. (See Figure 7)

After locating the center of the hole, install the chimney as per the chimney manufacturer's instruction, using Underwriters' Laboratories, Inc. listed all-fuel residential type or Building Heating Appliance Chimney.

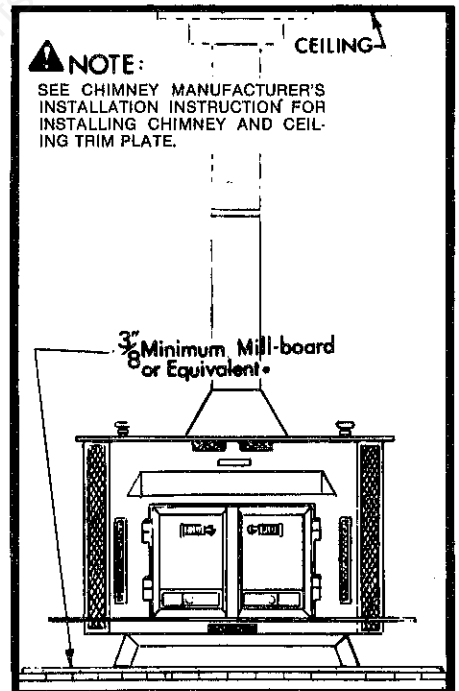

FIGURE 7 CHIMNEY MOUNTING CEILING

*See Section II, Floor Protection, Page 14.

Through-the-wall Penetration

Mark the plumb line on the wall directly behind the center of the stack (See Figure 8). Place the vertical position of the stove pipe and the elbow in position and project a point onto the plumb line level with the center of the elbow. Measure up so there will be at least $\frac{1}{4}$ " rise per foot of horizontal connector pipe, maintain clearances to ceiling noted in Figure 8. This will give you the center of the hole for the chimney penetration.

After locating the center of the penetration, install the chimney as per the chimney manufacturer's specifications.

Connect the stack to the chimney using #24-ga-minimum, blued or black steel connector pipe, 8" diameter, for models 26000-B and 27000-B and 10" diameter for model 28000. **DO NOT** use galvanized pipe. Connect each section so the crimped end faces downward, and secure each section to each other using at least three steel sheet metal screws or rivets.

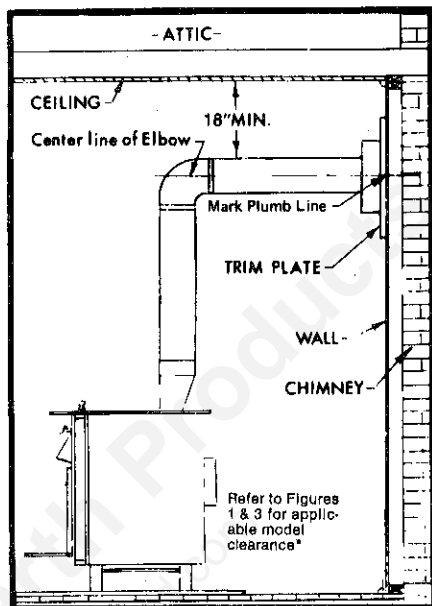

FIGURE 8 WALL CHIMNEY MOUNTING

When the chimney connector is connected using a 90° elbow and penetrating a wall into a flue, the minimum clearance from the top of the chimney connector and a ceiling is 18 inches (See Figure 8). In addition, all combustible materials must be removed $3\frac{1}{2}$ " around the complete circumference of the thimble extending through to the masonry of the flue. The open area is then concealed using a trim plate of the appropriate size.

Connections to an existing masonry flue must conform to the 1976 edition of the Uniform Mechanical Code, Section 915, paragraph E (Entering Masonry Chimney), which states:

"A connector entering a masonry chimney shall extend through the wall to the inner face of the liner, but not beyond, and shall be firmly cemented to masonry. A thimble may be used to facilitate removal of the connector for cleaning, in which case the thimble shall be permanently cemented in place with high temperature cement. The chimney connector shall enter the chimney not less than six inches from the bottom of the chimney. The chimney shall be provided with a cleanout. If six inches are not available, a cleanout shall be provided".

*See Section II, Floor Protection, Page 14.

FINAL CHECK

1. Recheck the specified clearances.
2. Remove all foreign material from the firebox area.
3. Open the primary air drafts and damper.
4. Plug the power cord into a **115 VAC** outlet, **do not** route the cord under the stove.
5. Place a crumpled piece of newspaper in the stove. Light it and close the doors. Ensure that the stove draws properly through the primary drafts. The paper should burn quickly and with a pronounced roaring sound.

6. Check for smoke leaks around the doors.

7. Open the doors and install the firescreen. Check for smoke escaping from the front of the stove. Smoking usually indicates a defective or poorly positioned chimney. If a thorough review of the installation instructions does not reveal the problem, contact your **BUCK STOVE** dealer for assistance.

TIPS ON FIRE BURNING

ASH BED — Prolongs burn and helps the thermostat function properly. For best results, the ash bed should be equal to the top ash bar.

GREEN WOOD vs. SEASONED WOOD — Green wood has a high moisture content, and therefore requires a hotter ignition temperature. It burns more rapidly in the stove because it needs more oxygen to keep burning. Seasoned wood — cut at least one year before use — allows for a quicker, prolonged burn and more complete combustion.

SPLIT WOOD vs. ROUND WOOD — Split wood burns easier and more rapidly, whether it's seasoned or green. If used after starting a fire, it should be packed tightly to achieve a longer burn. Round wood burns longer, but requires more effort to start. Inserting a round piece over a bed of red coals with the damper and drafts open will help it catch fire. Round wood should be used to accomplish an all-night burn.

FIRE STARTERS — Be highly selective in choosing a quick fire starter for use in your **BUCK STOVE. NEVER START A STOVE FIRE WITH GASOLINE, CHARCOAL LIGHTING FLUIDS, OR OTHER CHEMICALS WHICH COULD EXPLODE.** For best results, use Buck Lite™, a safe, quick fire starter available from your **Buck Stove** dealer. Regular, non-color newsprint may also be used.

HANDLE SHIELD MOUNTING

The shields are required for proper installation of your **Buck Stove**. They are to be mounted parallel with the handle, and spaced $2\frac{1}{2}$ " from the front of the boss to the front edge of the clamp. (see illustration).

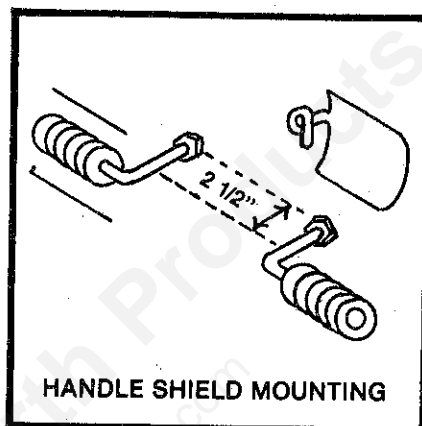

CATALYTIC CONVERTER RETRO-FIT UL LISTED FOR USE WITH MODELS 26000, 26000-B, 27000, and 27000-B

Your **BUCK STOVE** has been designed to be one of the safest, most efficient and economical woodstoves in the world. Now, these qualities can be further enhanced with the addition of the ARDEN INDUSTRIES "SMOKE GENIE" CATALYTIC SYSTEM, available at your **BUCK STOVE** dealer.

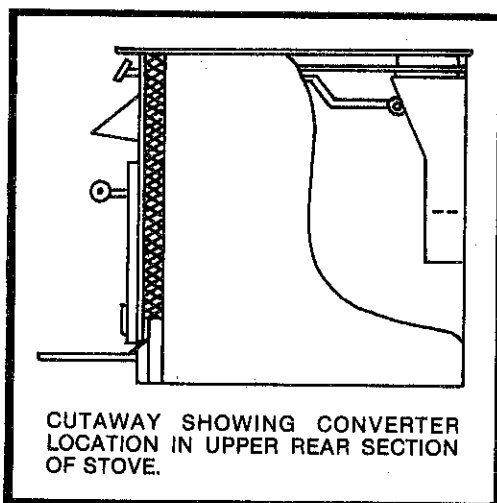

MODEL C200/R100 for LITTLE BUCK models 26000 and 26000-B

MODEL C200/R200 for REGULAR BUCK models 27000 and 27000-B

SECTION III

BUCKMATE FIREPLACE INSTALLATION

ZC-2-01/26000-B

ZC-3-01/27000-B

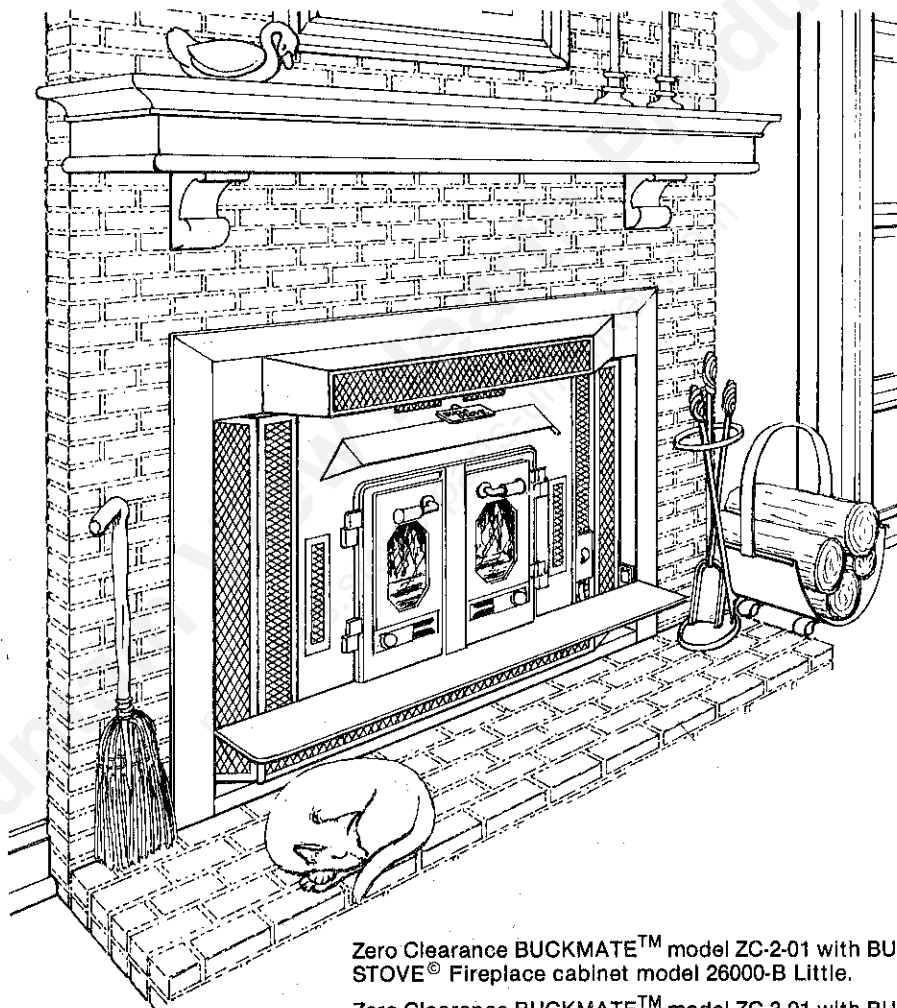

Zero Clearance BUCKMATE™ model ZC-2-01 with BUCK STOVE® Fireplace cabinet model 26000-B Little.

Zero Clearance BUCKMATE™ model ZC-3-01 with BUCK STOVE® Fireplace cabinet model 27000-B Regular.

FEATURES: INSTALLATION: MAINTENANCE: PREPARATION: OPERATION: SAFETY:



CAUTION - Refer to chimney manufacturers instructions for assembly and disassembly of chimney parts. Be sure to follow chimney instructions for proper clearances to combustibles and proper air spacing required.

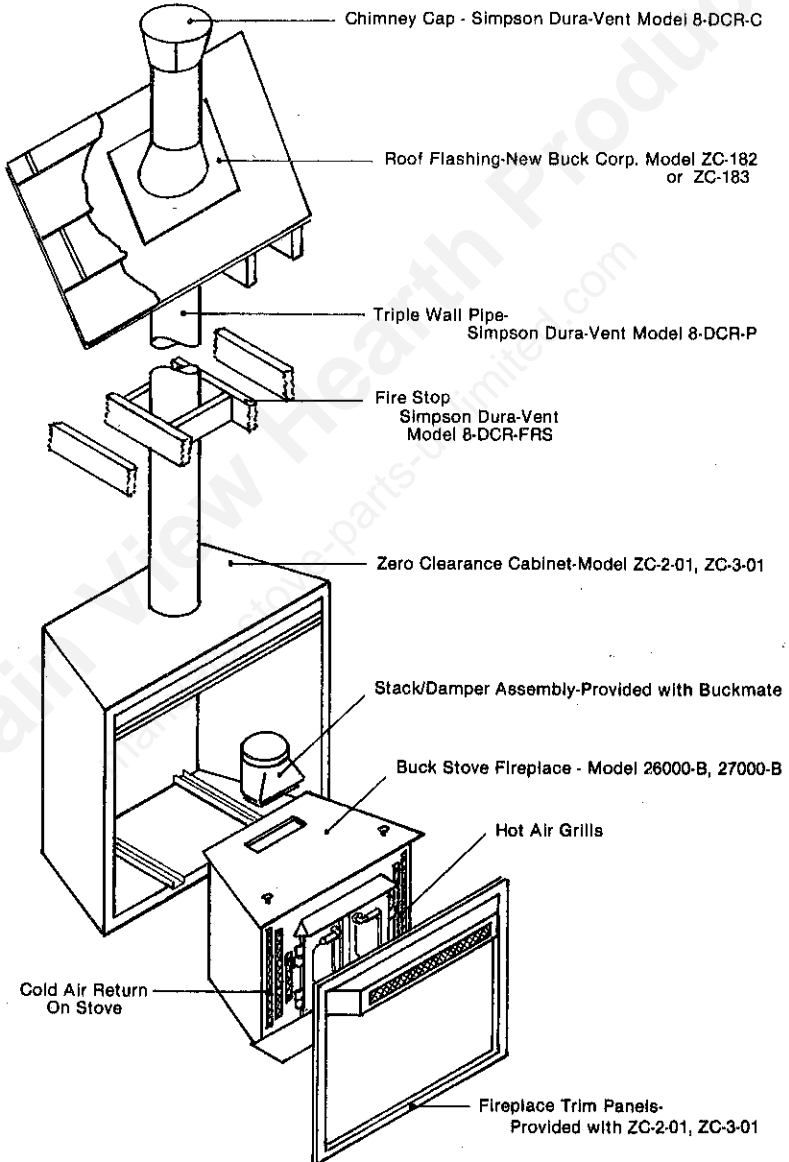

PARTS REQUIREMENTS

LISTED BUCK STOVE PARTS

ZC-2-01	BUCKMATE Zero Clearance Cabinet Assembly for 26000-B Stove
26000-B	Little Buck Stove
ZC-3-01	BUCKMATE Zero Clearance Cabinet Assembly for 27000-B Stove
27000-B	Regular Buck Stove
ZC-182	Flashing
ZC-183	Flat Roof Flashing

LISTED DURA-VENT CHIMNEY PARTS

DCR-P	8" Triple Wall Pipe Sections: 9", 12", 24", 36".
DCR-FRS	8" Firestop Radiation Shield
DCR-SC	8" Storm Collar
DCR-C	8" Chimney Cap

OPTIONAL DURA-VENT CHIMNEY PARTS

DCR-IS	8" Insulation Shield
DCR-WS	Wall Strap
DCR-RSA	Extended Roof Bracket
DCR-E	15° Elbows (2 Maximum)
DCR-ES	Elbow Strap

CAUTION: Read through all of these instructions carefully. Follow Dura-Vent Chimney Installation exactly. Failure to install the Cabinet, Stove, and Chimney as described in the instructions will void the manufacturer's warranty and may have an affect on your Homeowner's Insurance and UL Listing Status. A major cause of chimney related fires is failure to maintain required clearances (air spaces) to combustible materials. It is of utmost importance that these parts be installed only in accordance with these instructions.

The Zero-Clearance BUCKMATE Fireplace Cabinet Model ZC-2-01 (hereafter referred to as the BUCKMATE) is designed to facilitate the installation of a BUCK STOVE Model 26000-B (hereafter referred to as the BUCK STOVE Fireplace (FP)) in a family dwelling, where minimum clearance is desired. The Zero Clearance BUCKMATE Fireplace Cabinet Model ZC-3-01 is designed to facilitate the installation of a BUCK STOVE Model 27000-B. Just as the name implies, the Zero Clearance BUCKMATE may be installed in direct contact with building construction. Installed properly, the unit then provides a safe, insulated housing for the BUCK STOVE Fireplace.

Normally, the installation will be accomplished in two stages: 1) Installation of the BUCKMATE Fireplace Cabinet and associated framing and mortarwork, and 2) later installation of the BUCK STOVE (FP) into the BUCKMATE Fireplace Cabinet.

INSTALLATION PRECAUTIONS

The following precautions are mandatory for a safe installation:

- A. Compliance with local building codes and regulations is mandatory.
- B. Be careful not to damage unit in handling and unpacking component parts and accessories.
- C. The only factory approved chimney pipe to be used is Underwriters Laboratories listed Simpson Dura-Vent Chimney Model 8-DCR vented to the outside of the building.
- D. The chimney must extend a minimum of three feet above the highest point where it penetrates the roof (three feet above a flat roof or up to a 2/12 pitch roof), and the chimney must extend a minimum of two feet higher than any portion of the building within ten feet of the chimney. The minimum height is 14½ feet. The maximum height is 22½ feet. A two-inch clearance must be maintained between the chimney and any combustible materials at all points.
- E. A rain cap must be used to terminate the chimney to prevent down-draft. The only factory approved rain cap to be used is Underwriters Laboratories Listed Simpson Dura-Vent 8-DCR-C with spark arrestor.
- F. Use only New Buck Corp. Roof Flashings when installing the BUCKMATE Cabinet, Chimney and 26000-B Fireplace.
- G. The BUCKMATE Fireplace Cabinet is not intended for use in mobile homes.
- H. DO NOT build a fire directly inside the BUCKMATE. It is designed solely for housing the BUCK STOVE Fireplace.

SELECTING A CHIMNEY INSTALLATION AND LOCATION

There are two basic types of chimney installations possible with the BUCKMATE; Straight up through a ceiling, and chase installation, either outside or inside. These are normally used as follows:

⚠ CAUTION - Refer to chimney manufacturers instructions for assembly and disassembly of chimney parts. Be sure to follow chimney instructions for proper clearances to combustibles and proper air spacing required.

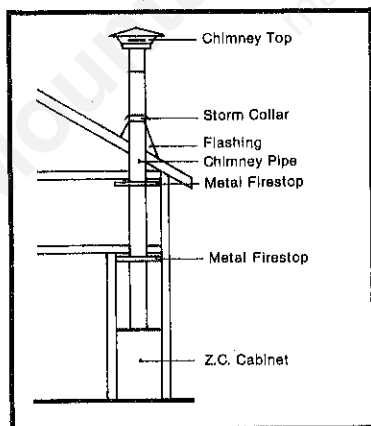

FIGURE 1 Through Ceiling & Normal Pitch Roof

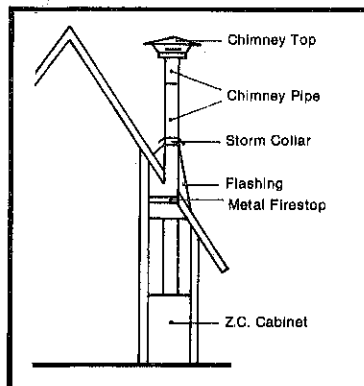

FIGURE 2 Through High Pitch Roof

- a. Straight up through ceiling: (See Figures 1 and 2). This is a simple installation normally used when installing a BUCKMATE inside an existing room, and in some cases, in new construction. Refer to Figure 3 if an offset to clear an obstruction is needed.



CAUTION - Refer to chimney manufacturers instructions for assembly and disassembly of chimney parts. Be sure to follow chimney instructions for proper clearances to combustibles and proper air spacing required.

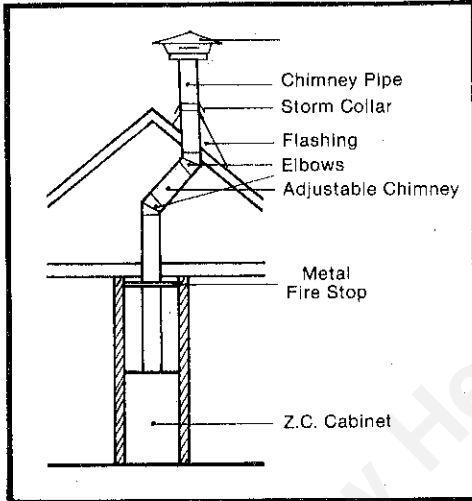

FIGURE 3 OFFSET TO CLEAR OBSTRUCTION

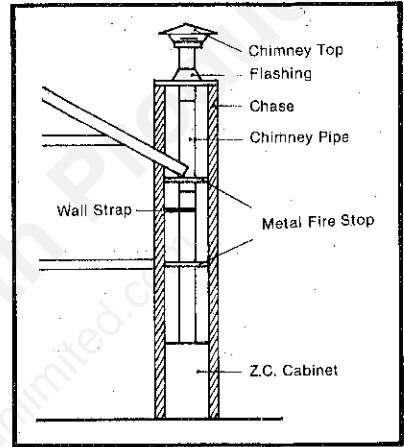

FIGURE 4 EXTERIOR WALL CHASE

- b. Chase Installation: (See Figure 4). A chase is an enclosure built specifically to house a chimney. The interior of a chase is open from the BUCKMATE to the roof, eliminating the need to cut through ceilings and the roof. Normally, a chase is built outside and against the exterior wall of a home. A hole is cut through the wall, and the BUCKMATE is located in the bottom of the chase, with the front of the unit flush with the interior wall. Chases are commonly veneered on the outside with brick, stone or wood to give the appearance of a conventional fireplace flue. Occasionally, they are built inside and boxed in, similar to a stairwell. When making a chase installation, it is important to read the chimney manufacturer's instructions prior to building, as there are specific requirements for bracing a free-standing flue that must be planned for. There are also occasions where offsets are used within a chase to accommodate unusual building designs, or to locate the BUCKMATE further into a room.

NOTE: Chases require waterproof covers that are not commercially available due to the nonstandard designs of chases. Make sure that units fabricated by local sheet metal shops completely overhang the chase and all masonry. Otherwise, rain leakage or freezing and fracturing of standing water will occur.

FRAMING CONSTRUCTION AND INSTALLATION

ZC-2-01/26000-B (Little BUCKMATE Cabinet and Little Buck Stove Fireplace)

FRAMING CONSTRUCTION

Except as noted, the BUCKMATE can be installed almost anywhere you desire. There are, however, a few clearance and framing restrictions that must be followed. See figure 1 and 2 to make sure that these clearance restrictions are met. It is much wiser to place your BUCKMATE correctly at the start of the installation than to be forced to relocate it after much of the work is done.

You must ensure that the floor is of adequate strength to accept the load of this unit. If inadequate, the floor will require additional support, such as bracing. **NOTE:** A wooden base constructed of plywood or 2" x 4" boards is required in order to get proper clearance above the extended hearth (millboard, rock, stone, etc.)

Good planning is essential for a satisfactory installation, therefore, at this point you should have decided where the BUCKMATE is to be located and the route the chimney will follow to the roof - straight up, or chase. If you cannot decide the best route, contact your BUCK STOVE Dealer for assistance with the planning.

CHIMNEY INSTALLATIONS

Position BUCKMATE for chimney installation as follows:

- Thoroughly clean the area where the unit will be placed.
- Lay out the location on the floor and construct base (see Figure 1).
- If chimney is to be installed through a ceiling, drop a plumbline, locate, and mark point on ceiling directly over center of BUCKMATE chimney adapter.
- Install the chimney in accordance with chimney manufacturer's recommendations.

CAUTION: Follow the instructions for the type chimney you're building: i.e., straight-up or chase.

- Note, the maximum height of chimney is 22½ feet.

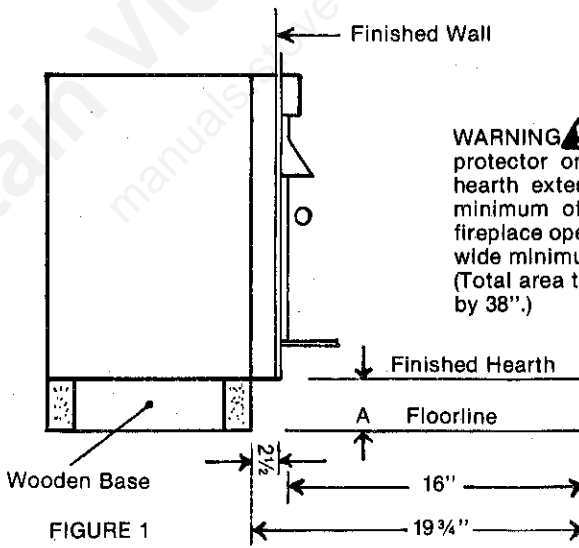

Base for BUCKMATE must be level with or slightly higher than finished hearth height - dimension (A) Figure 1. Front of BUCKMATE cabinet must be recessed 2½" from finished wall.

ZC-2-01/26000-B

Framing must be accomplished after the BUCKMATE is set in place. The chimney can be installed after framing, but installation is considerably more difficult and, in some cases, impossible. Therefore, it is recommended that the chimney be installed prior to framing when a choice exists.

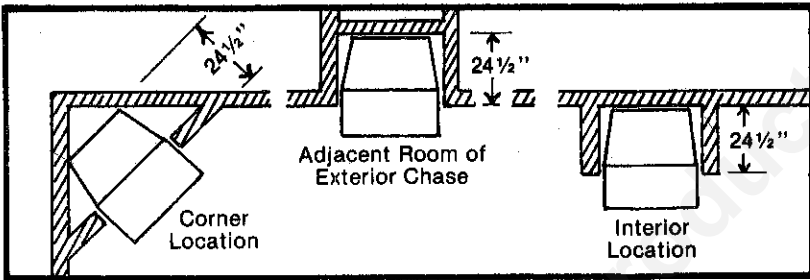
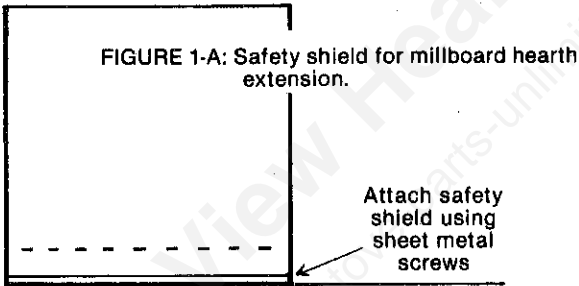

FIGURE 2

Above (Figure 2) are Framing location examples, with depth dimensions for some typical configurations. These are finished measurements so install accordingly.

1. Before framing, combustible floor coverings (carpet, tiles, etc.) must be removed to outer dimension of unit framing, including the 16" x 38" area for the hearth extension.



WARNING: Install the hearth protector only as specified. The hearth extension must extend a minimum of 16" in front of the fireplace opening and must be 38" wide minimum.

FIGURE 1-B: Safety shields for brick or rock hearth (Note: Cut vertical shield to fit installation height as needed. Use 26 Ga. Minimum metal being sure to cover any combustibles on the base.)

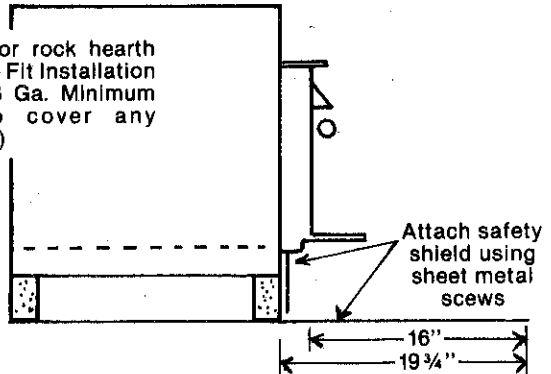

2. Set BUCKMATE unit in place and attach safety shield to unit as shown in Figure 1-A and 1-B. You must place a non-combustible material 3/8" thick millboard or equivalent .084K factor or 2" of masonry (brick or rock) over this area as a minimum.

3. Frame the BUCKMATE using 2" x 4" studs or local building code framing. Some minor framing restrictions are required:

- Adjacent side walls must be at least 29 1/2" from door opening of the BUCK STOVE 26000-B.
- The overall opening dimensions must be at least 38" wide and 34 1/4" high.
- Framing must protrude 2 1/2" to allow for finished wall to come flush with the back of the BUCKMATE trim panel. (See Figures 1A and 1B.)

⚠ CAUTION: Refer to chimney manufacturers instructions for assembly and disassembly of chimney parts. Be sure to follow chimney instructions for proper clearances to combustibles and proper air spacing required.

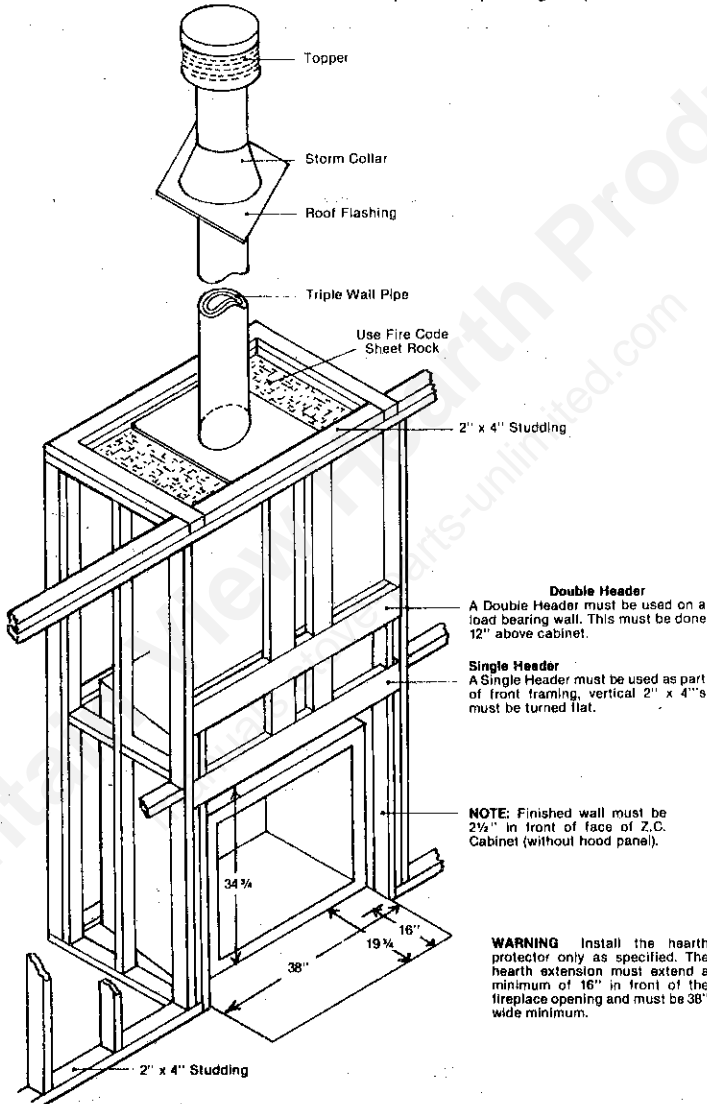

FIGURE 3 EXTERIOR ROOF OR CHASE

WARNING ⚠ Install the hearth protector only as specified. The hearth extension must extend a minimum of 16" in front of the fireplace opening and must be 38" wide minimum.

CAUTION: Refer to chimney manufacturers Instructions for assembly and disassembly of chimney parts. Be sure to follow chimney instructions for proper clearances to combustibles and proper air spacing required.

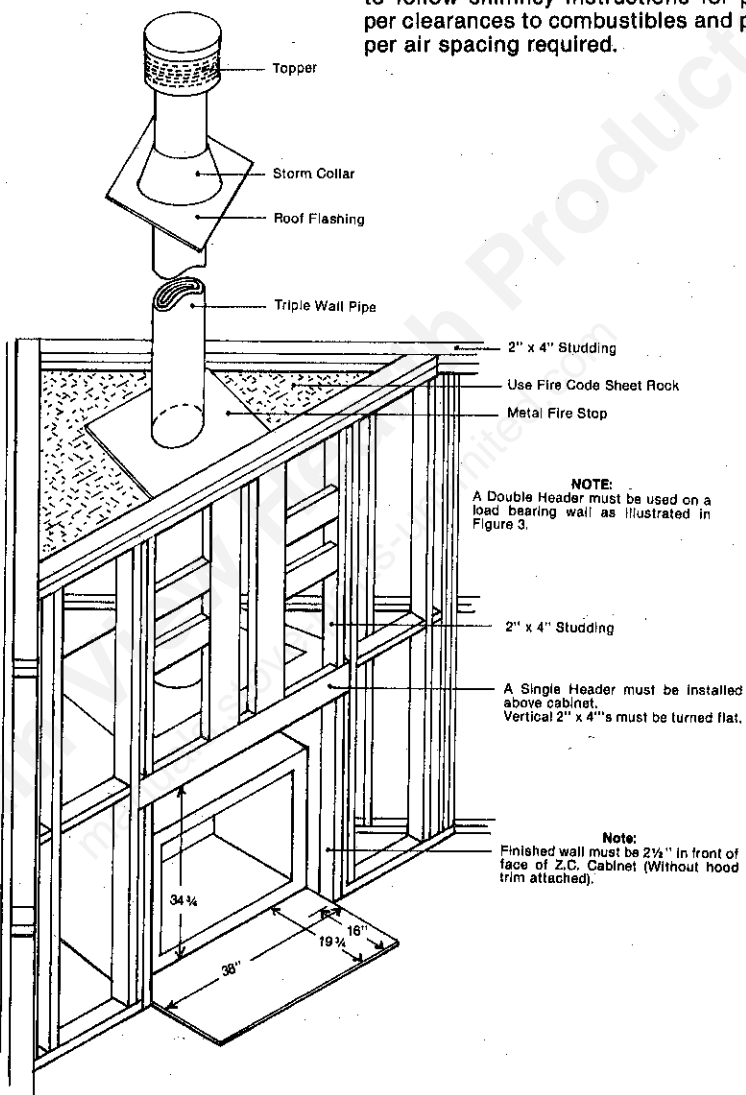

FIGURE 3A CORNER LOCATION FRAMING

WARNING Install the hearth protector only as specified. The hearth extension must extend a minimum of 16" in front of the fireplace opening and must be 38" wide minimum.

FRAMING CONSTRUCTION AND INSTALLATION

ZC-3-01/27000-B (Regular BUCKMATE Cabinet and Regular Buck Stove Fireplace)

FRAMING CONSTRUCTION

Except as noted, the BUCKMATE can be installed almost anywhere you desire. There are, however, a few clearance and framing restrictions that must be followed. See figure 1 and 2 to make sure that these clearance restrictions are met. It is much wiser to place your BUCKMATE correctly at the start of the installation than to be forced to relocate it after much of the work is done.

You must ensure that the floor is of adequate strength to accept the load of this unit. If inadequate, the floor will require additional support, such as bracing. NOTE: A wooden base constructed of plywood or 2" x 4" boards is required in order to get proper clearance above the extended hearth (millboard, rock, stone, etc.)

Good planning is essential for a satisfactory installation, therefore, at this point you should have decided where the BUCKMATE is to be located and the route the chimney will follow to the roof - straight up, or chase. If you cannot decide the best route, contact your BUCK STOVE Dealer for assistance with the planning.

CHIMNEY INSTALLATIONS

Position BUCKMATE for chimney installation as follows:

- Thoroughly clean the area where the unit will be placed.
 - Lay out the location on the floor and construct base (see Figure 1).
 - If chimney is to be installed through a ceiling, drop a plumbline, locate, and mark point on ceiling directly over center of BUCKMATE chimney adapter.
 - Install the chimney in accordance with chimney manufacturer's recommendations.
- CAUTION:** Follow the instructions for the type chimney you're building: i.e., straight-up or chase.
- Note, the maximum height of chimney is 22½ feet.

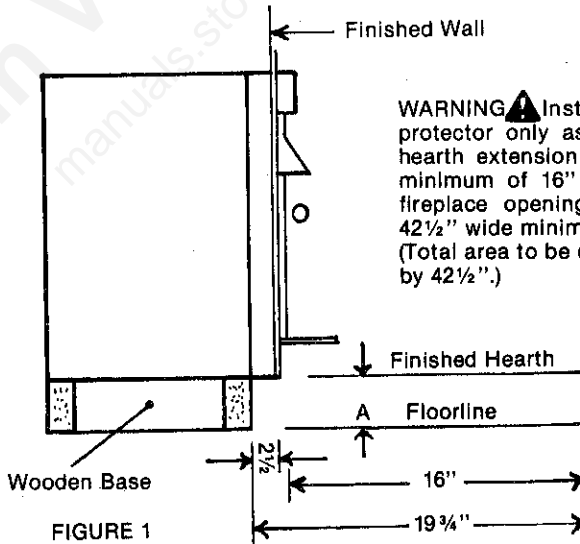

Base for BUCKMATE must be level with or slightly higher than finished hearth height - dimension (A) Figure 1. Front of BUCKMATE cabinet must be recessed 2½" from finished wall.

FRAMING

ZC-3-01/27000-B

Framing must be accomplished after the BUCKMATE is set in place. The chimney can be installed after framing, but installation is considerably more difficult and, in some cases, impossible. Therefore, it is recommended that the chimney be installed prior to framing when a choice exists.

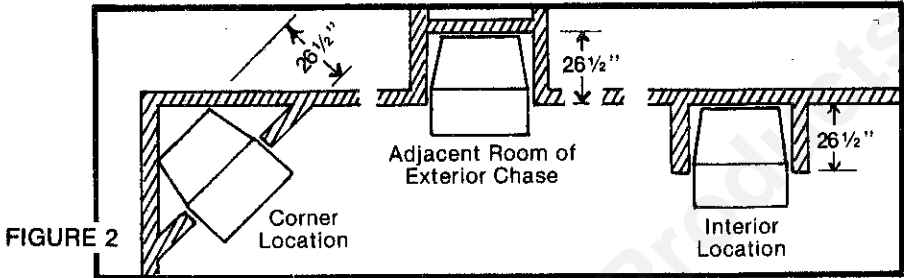

Above (Figure 2) are framing location examples with depth dimensions for some typical configurations. These are finished measurements so install accordingly.

1. Before framing, combustible floor coverings (carpet, tiles, etc.) must be removed to outer dimension of unit framing, including the 16" x 42 1/2" area for the hearth extension.

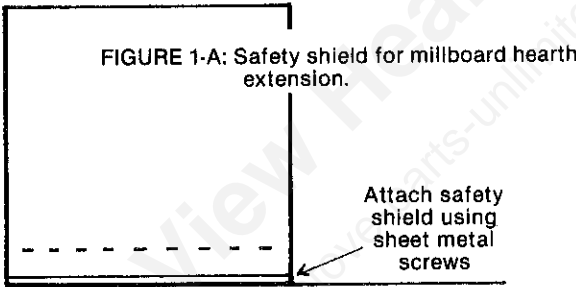

WARNING Install the hearth protector only as specified. The hearth extension must extend a minimum of 16" in front of the fireplace opening and must be 42 1/2 wide minimum.

FIGURE 1-B: Safety shields for brick or rock hearth (Note: Cut vertical shield to fit installation height as needed. Use 26 Ga. Minimum metal being sure to cover any combustibles on the base.)

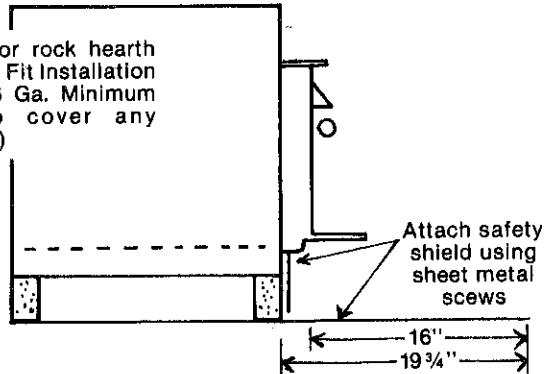

2. Set BUCKMATE unit in place and attach safety shield to unit as shown in Figure 1-A and 1-B. You must place a non-combustible material 3/8" thick millboard or equivalent .084K factor or 2" of masonry (brick or rock) over this area as a minimum.

3. Frame the BUCKMATE using 2" x 4" studs or local building code framing. Some minor framing restrictions are required: -

- Adjacent side walls must be at least 29 1/2" from door opening of the BUCK STOVE 27000-B.
- The overall opening dimensions must be at least 42 1/2 wide and 36 3/4 high.
- Framing must protrude 2 1/2" to allow for finished wall to come flush with the back of the BUCKMATE trim panel. (See Figures 1A and 1B.)

⚠ CAUTION: Refer to chimney manufacturers instructions for assembly and disassembly of chimney parts. Be sure to follow chimney instructions for proper clearances to combustibles and proper air spacing required.

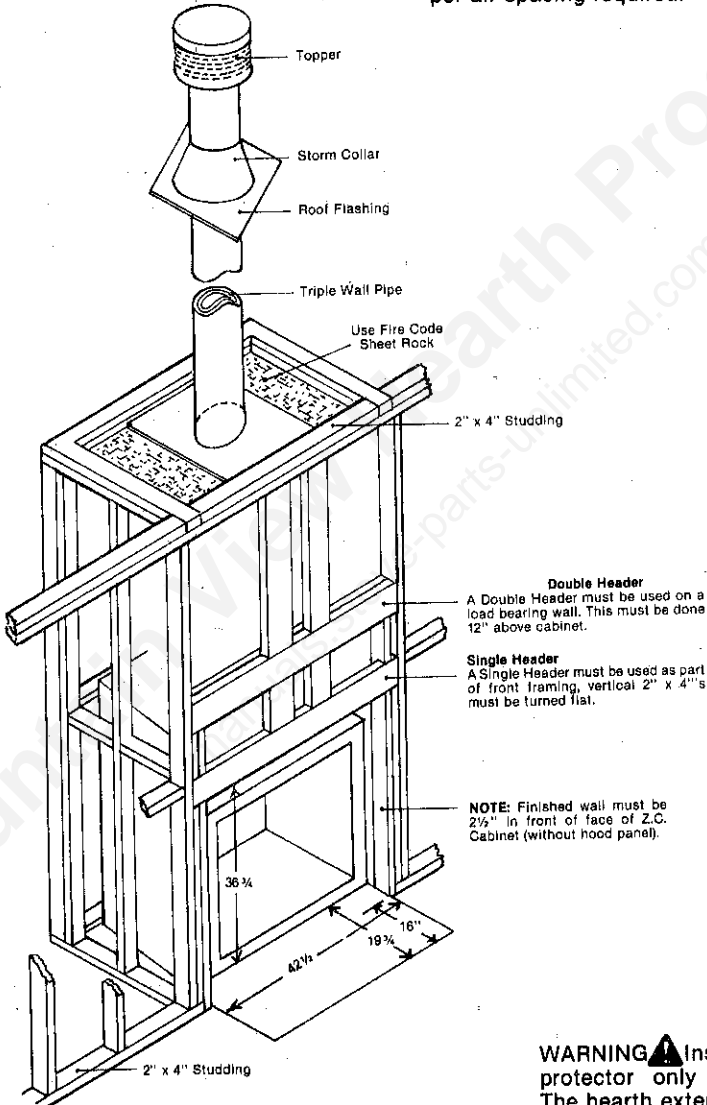

FIGURE 3 EXTERIOR ROOF OR CHASE

WARNING ⚠ Install the hearth protector only as specified. The hearth extension must extend a minimum of 16" in front of the fireplace opening and must be 42½" wide minimum.

CAUTION: Refer to chimney manufacturers instructions for assembly and disassembly of chimney parts. Be sure to follow chimney instructions for proper clearances to combustibles and proper air spacing required.

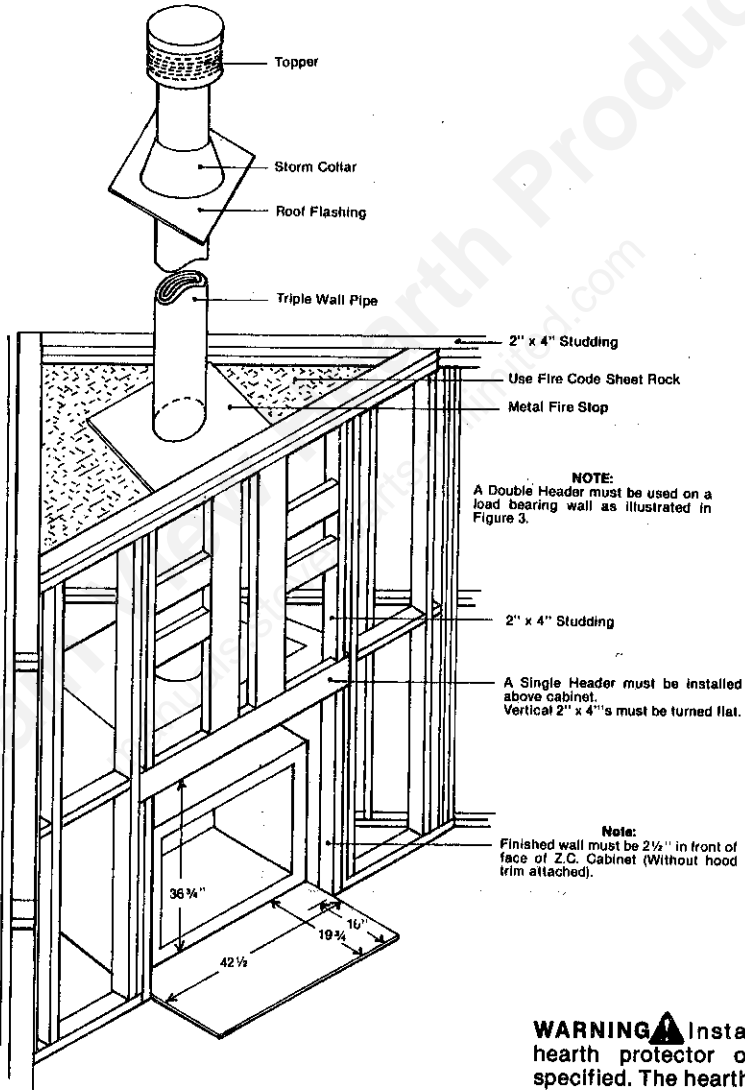
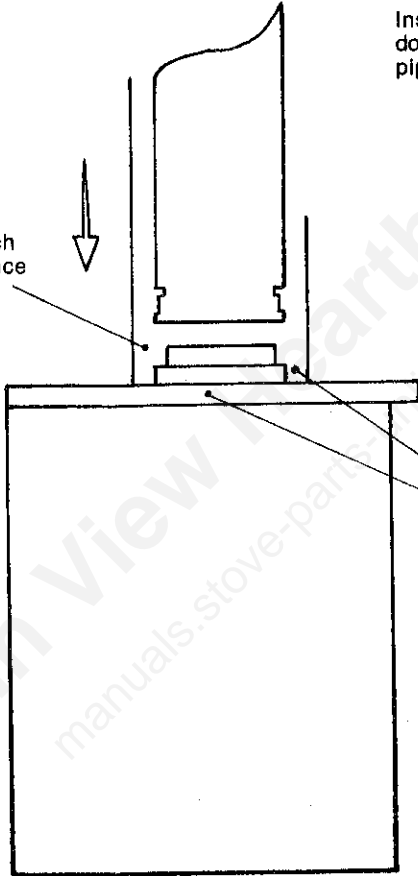

FIGURE 3A CORNER LOCATION FRAMING

WARNING Install the hearth protector only as specified. The hearth extension must extend a minimum of 16" in front of the fireplace opening and must be 42 1/2" wide minimum.

Maintain a 2 inch
minimum clearance



Install pipe to cabinet by pushing
down over the starter section of
pipe on the ZC Cabinet.

⚠ WARNING: Do not pack re-
quired air spaces on top of
cabinet or around pipe starter
section with insulation or other
materials.

INSTALLING FIRESTOP RADIATION SHIELD: Nail the Firestop Radiation Shield to the bottom of the framed ceiling opening using at least two 8-penny nails per side.

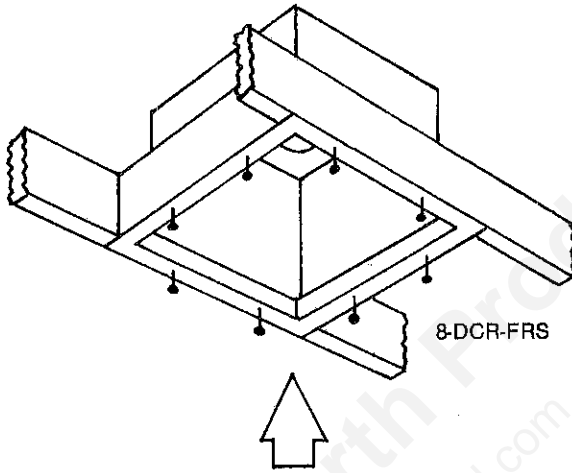

Chimney Installation Information

ROOF CLEARANCE

Frame a square opening in roof maintaining the required 2" clearance to combustible materials between the chimney and the framed opening and roofing material.

INSULATION SHIELD

FIRESTOP RADIATION SHIELD

Provides proper clearance. 2" clearance does not apply.

Clearance between chimney and enclosing wall - 2"

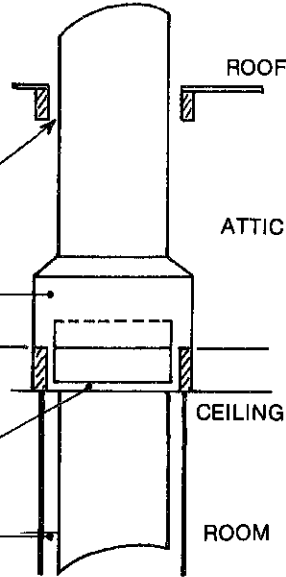

8" Chimney fits between standard 16" OC joists.

ELECTRICAL INSTALLATION

Electrical procedures: The BUCKMATE is not pre-wired; an electrician must wire the BUCKMATE into the home wiring system using No. 14 AWG (with ground wiring) as minimum in accordance with local wiring codes. (See Figure 4.)

1. Remove receptacle cover.
2. Remove receptacle from mounting box.
3. Run No. 14 AWG wire directly from house wiring in through the Field Connector in the lower right side of the BUCKMATE. Leave 4-6 inches of wire extending out of the box.
4. Tighten Field Connector around wire.
5. Wire receptacle (black, white, and ground) and resecure to mounting box.
6. Replace receptacle cover.

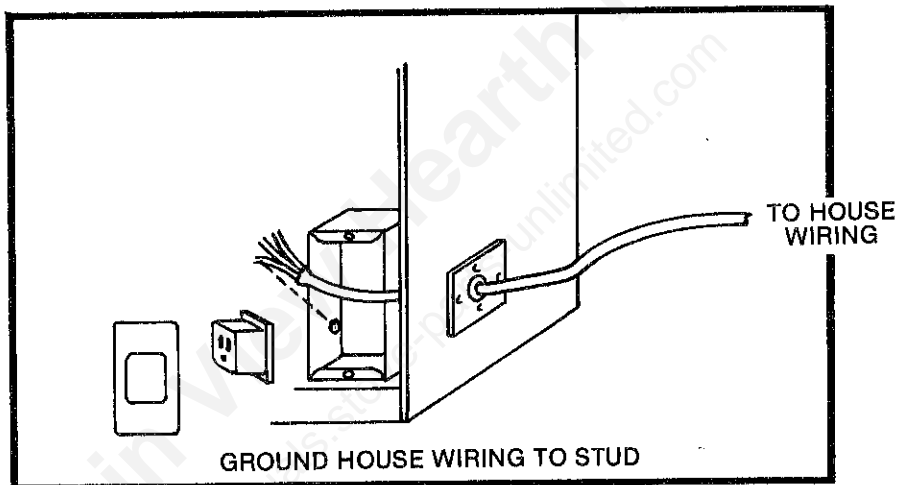

FIGURE 4 POWER HOOK-UP

FINISHING

Finishing can now be completed using the desired material in accordance with local building and fire codes.

CAUTION: Do not cover any opening on the BUCKMATE; heat must be allowed to escape from the openings designed into the unit. A grilled trim panel is provided with the trim package to cover this area. Also, the grilled opening at the bottom front of the BUCKMATE cannot be blocked.

A hearth extension must extend to a minimum of 16" in front of the fireplace opening. The mantel must be positioned a minimum of 20" above the top of the trim kit hood.

Use a non-combustible millboard having a thermal conductivity of $K = 0.84$ BTU in./ft.²H°F or a listed floor protector. The millboard or floor protector may be covered with a non-combustible material such as marble, slate, tile, etc.

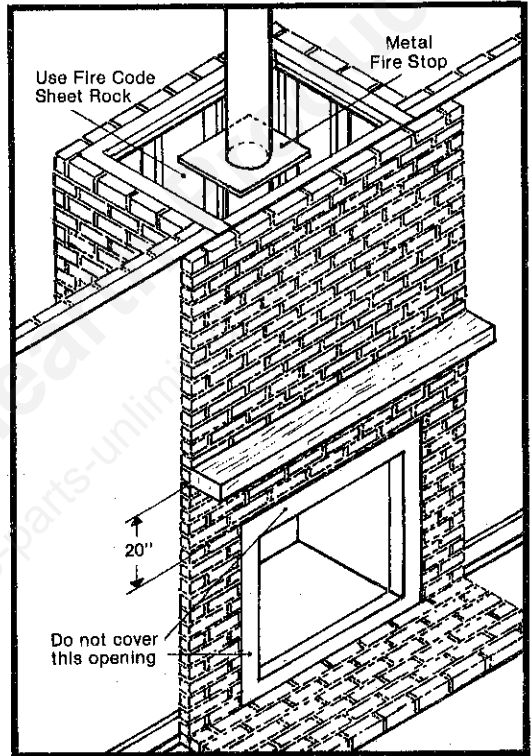

ALL DIMENSIONS
SHOWN ARE
MINIMUM ALLOWED
FOR WARRANTY

INSTALLING THE BUCK STOVE

Install unit as follows:

- a. Carefully reinspect chimney connections, vent outputs and cabinet air intakes after finishing is completed.
- b. Thoroughly clean all masonry mud and debris from cabinet and surrounding environment.
- c. Ensure that BUCKMATE has not been damaged during masonry process.
- d. Remove protective plastic wrapping from fireplace.
- e. Inspect motor and associated hardware for damage.
- f. Remove doors to facilitate installation.
- g. Slide the BUCK STOVE FIREPLACE into the BUCKMATE all the way to the back so that the BUCK STOVE FIREPLACE fits squarely against the back stove stop.

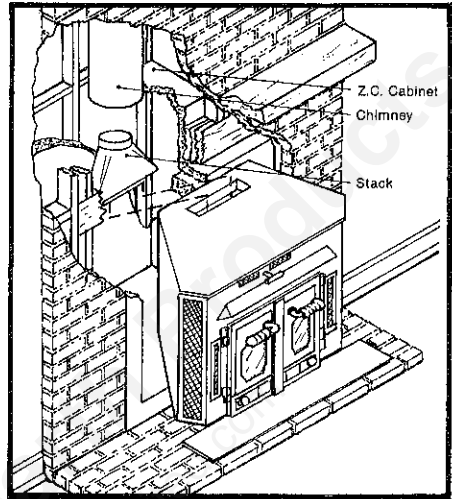

FIGURE 7 INSTALLING STACK TO CHIMNEY

- h. Turn stack positioning nuts counter-clockwise allowing stack to be lowered. Push downward and fit evenly until recessed within the stack opening (containing the damper.) Secure tightly with "T" clamps, bolts, and nuts provided. (See Figures 7 & 8). Ensure stack mates squarely, and gasket seals completely.

CAUTION: Before installing trim panels, recheck BUCKMATE air intake and output openings for obstructions. Ensure that finishing materials have not been built over openings. This is very critical. Attach the stack by placing the stack brackets down on the lip on the inside lower edge of the stack. Insert the bolts through the holes in the damper brackets and fasten securely with the lock washers and nuts provided. Be sure the stack sits squarely on the top of the stove with the gasket material making a good seal. (See Figure 8).

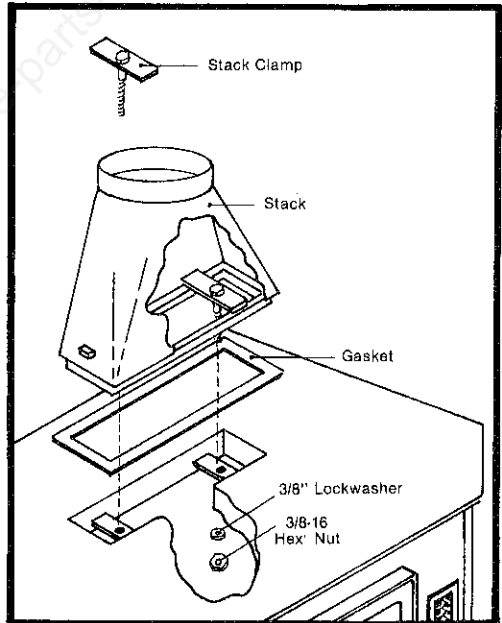

FIGURE 8

(MOUNTING STACK)

- i. Install the trim kit attaching it to the BUCKMATE or finished framing by using 1" screws to secure the trim panels in place.
- j. Remove cover plate from BUCKMATE exposing receptacle. Roll up power cord so it will fit inside of cover box. Plug in power cord in receptacle. Replace cover plate. (See Figure 9).
- k. Stove Doors are made of high quality cast iron which resist warpage over conventional steel doors and should never require hinge adjustment. Inside glass and draft block mounting screws should periodically be inspected for tightness. If the screw becomes loose, retighten.
- l. Check primary air draft control on each door.

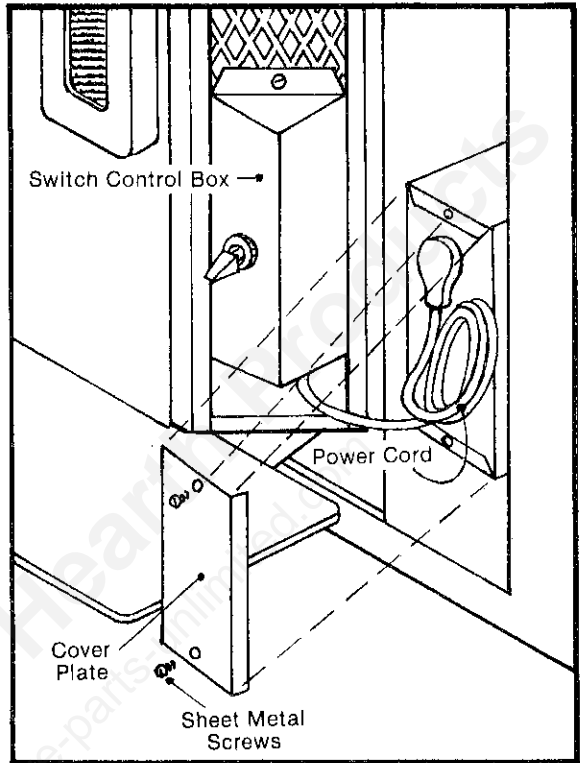

FIGURE 9

FINAL CHECK-OUT

Perform final check-out as follows:

- a. Remove all foreign material from stove firebox and set firedogs in place.
- b. Flip blower switch to AUTOMATIC. Blower should stop. The thermostat will automatically cycle the blower on and off when a fire is burning in the stove.
- c. Open primary air draft controls on doors, and open damper completely.
- d. Place a piece of newspaper in the stove, light it and close the doors. Ensure that the stove draws properly through the primary air intakes. The paper should burn very quickly with a pronounced roaring sound.
- e. Open the doors and install the fireplace screen. Make sure that no smoke escapes from the front of the stove with the doors opened. Smoking indicates a defective or poorly positioned chimney. If a thorough review of the installation requirements does not reveal the problem, contact your BUCK STOVE Dealer for assistance.

CHIMNEY MAINTENANCE

Creosote and Soot - Formation and Need for Removal:

When wood is burned slowly, it produces tar and other organic vapors, which combine with expelled moisture to form creosote. The creosote vapors condense in the relatively cool chimney flue of a slow-burning fire. As a result, creosote residue accumulates on the flue lining. When ignited, this creosote makes an extremely hot fire.

Chimney Cleaning:

1. **Access** - Chimneys must be installed so that access is provided for inspection and cleaning.

2. **When to Clean** - The chimney should be inspected at least once every month during the heating season to determine if a creosote or soot has built up. Check spark arrestor screens every 2-4 weeks. If creosote or soot has accumulated, it should be removed to reduce the risk of chimney fire.

3. **How to Clean** - Have your chimney cleaned by a professional chimney sweep if you have doubts about your ability to clean it, using a plastic, wood, or steel brush. Do not use a brush that will scratch the stainless steel liner of your chimney. Scrub the spark arrestor with a wire brush.

To remove the Chimney Cap for cleaning, unscrew the four screws that attach the cap's support legs to the cap base. The Tee Cleanout Cap can be removed once the screws are unscrewed. Remember to replace the screws when you are through cleaning the chimney.

4. **Coal** - To reduce corrosion in chimneys where coal is burned, clean the chimney thoroughly within 48 hours of shutting down the stove for the season. Check the chimney's lining for sulfuric acid corrosion regularly.

5. **No Chemical Cleaners** - Do not use chemical chimney cleaners. Their use does not eliminate the need for mechanical cleaning and they may be highly corrosive.

6. **In Case of Fire** - If a flue fire occurs, close all appliance draft openings and call your Fire Department. Do not use the chimney again until it is inspected for possible damage.

7. **Chimney Protection - Painting.** To increase chimney life, coat all exterior metal parts with high temperature rust-proof paint. This is highly recommended, particularly in areas near the ocean. Wash the metal with a vinegar and water solution before painting.

SECTION IV

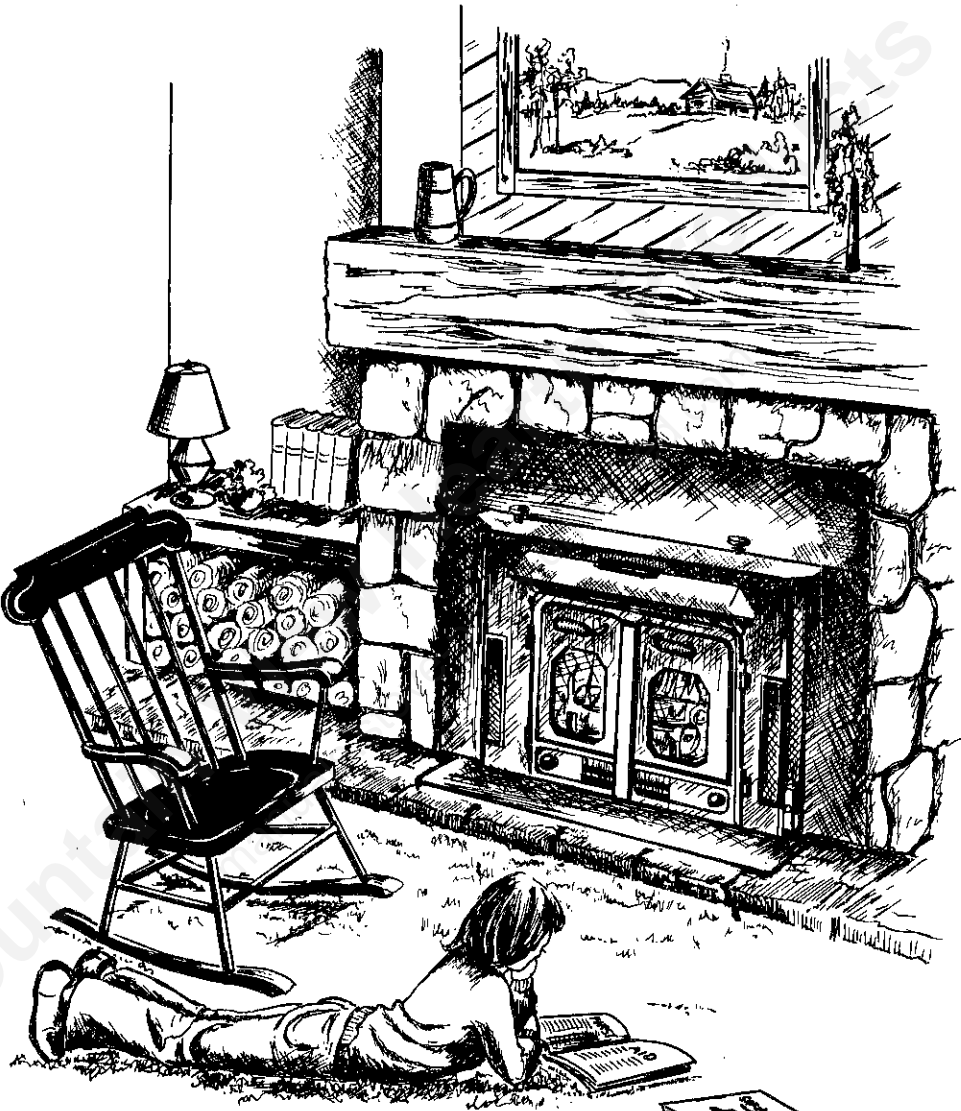

▲ SAFETY ▲

WOOD STOVE SAFETY

Certain safety hazards are inherent in any wood stove installation. You should be aware of these so that a safe and proper installation can be made.

1. FAULTY CHIMNEY: An older masonry chimney should be thoroughly checked to be sure there are no holes or weak spots which could allow sparks or hot gasses to escape.

HEAT CONDUCTION: Placing combustible materials too close to a stove or chimney can be a fire hazard.

By keeping these particular hazards in mind as you install and use your **BUCK STOVE** you can ensure a safe, reliable installation.

SAFETY PRECAUTIONS

For your protection, read and follow these safety precautions closely:

1. Use a spark arresting shield (3/8" mesh) on top of the chimney. Check monthly as this is a code requirement in some areas.
2. Use smoke detectors around the stove as well as in sleeping areas.
3. Keep a fire extinguisher rated for Class "A" fires near the stove.
4. Check with your insurance company to be sure your policy covers the installation and use of a wood stove.
5. Creosote—Formation and Need for Removal: When wood is burned slowly, it produces tar and other organic vapors, which combine with expelled moisture to form creosote. The creosote vapors condense in the relatively cool chimney flue of a slow-burning fire. As a result, creosote residue accumulates on the flue lining. When ignited this creosote makes an extremely hot fire.

The connector and/or chimney should be inspected at least twice monthly during the heating season to determine if a creosote buildup has occurred.

If creosote has accumulated, it should be removed to reduce the risk of a chimney fire.

6. Locate furniture and any other combustibles away from the stove.
7. Store firewood at a safe distance from the stove.
8. Disposal of Ashes: Ashes should be placed in a metal container with a tight fitting lid. The closed container of ashes should be placed on a noncombustible floor or on the ground, well away from all combustible materials, pending final disposal. If the ashes are disposed of by burial in soil or otherwise locally dispersed, they should be retained in the closed container until all cinders have thoroughly cooled. Ashes can ignite up to 72 hours after removal.
9. Always exercise caution when using your **BUCK STOVE**. Be particularly careful when there are children around an operating stove.

CAUTION: NEVER use gasoline, gasoline-type lantern fuel, kerosene, charcoal lighter fluid or similar liquids to start or "freshen up" a fire in the **BUCK STOVE**. Keep all such liquids well away from the stove when it is in use. All fluids of this type give off highly volatile fumes and can **WILL EXPLODE!** Don't take a chance with the safety of your home and family.

SECTION V

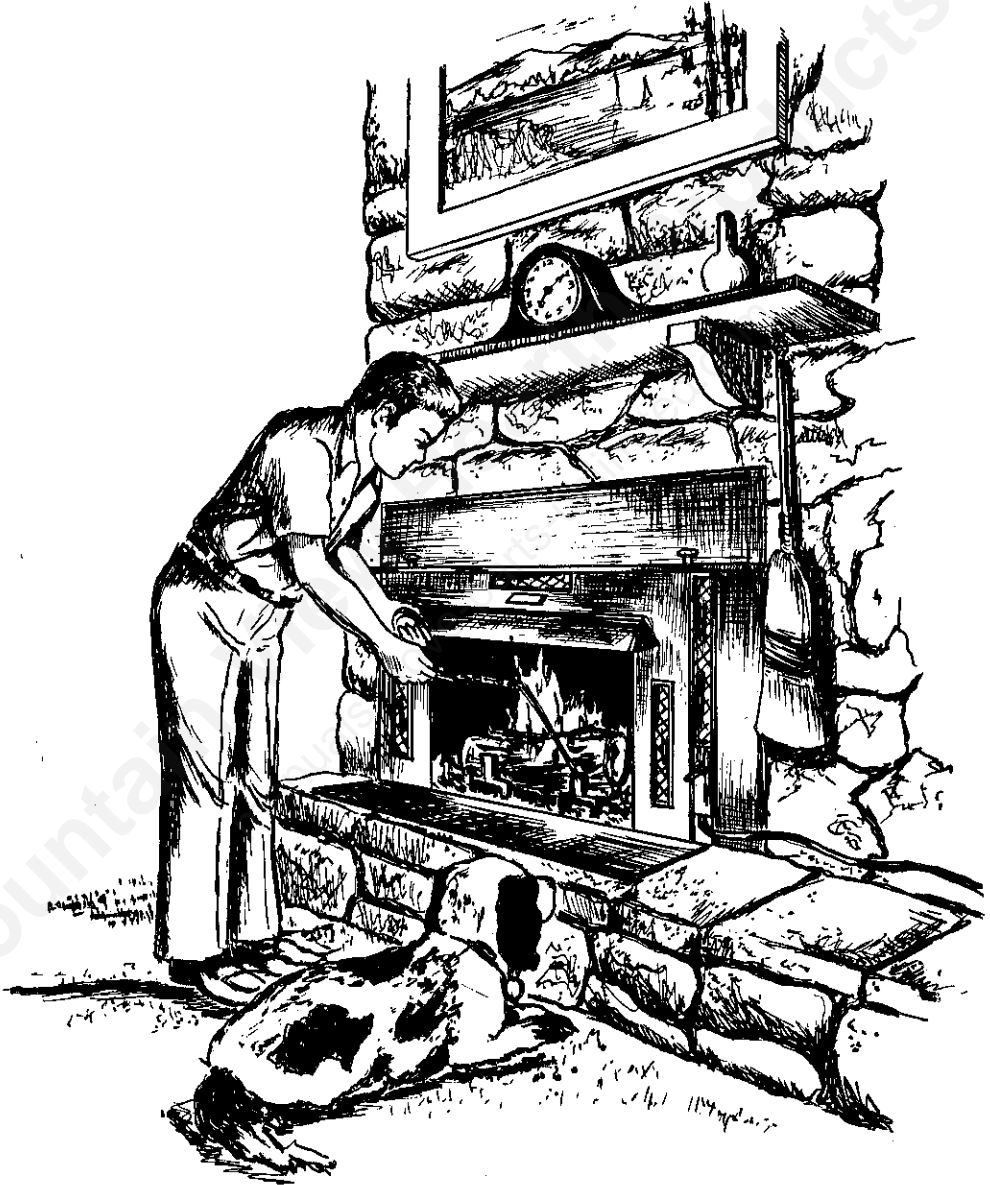

OPERATION

SECTION V - OPERATION

This section of the manual is to help you get the maximum efficiency and utility from your **BUCK STOVE**. If you should experience any difficulty or have any questions concerning your **BUCK STOVE**, contact your **BUCK STOVE** dealer for assistance.

BUILDING A FIRE FOR MAXIMUM EFFICIENCY: Because the **BUCK STOVE** burns wood and extracts heat so efficiently, a large fire is not necessary. A large fire not only wastes energy, it usually results in the home being too warm for comfort.

The following steps will serve as a guide for operating your **BUCK STOVE**.

BUILDING A FIRE:

▲ DANGER - Never build fire directly in **BUCKMATE** Cabinet unless stove is installed.

1. Place the blower control switch in the "AUTOMATIC" position.
2. Open the damper fully. Lift up on the damper handle and push it in as far as it will go.
3. Unlock and open the draft controls on the doors.
4. Open the doors by rotating the right handle up (counter-clockwise). Twist two pieces of newspaper into a roll and place them on the floor of the firebox.
5. Lay several pieces of dry kindling on top of the newspaper.
6. Place three or four pieces of firewood, 3-5" in diameter, on top of the firelogs.
7. Light the newspaper in the front, close and latch the doors. **▲ NOTE:** Do not leave the fire unattended at this point. The draft system of the **BUCK STOVE** will start the fire very quickly.
8. When the fire is burning well, close the damper all the way. Should the stove begin to smoke, open the damper slowly until the smoking stops. This position of the damper is a function of the chimney size and height and the amount of draw. Continued smoking indicates an obstructed, defective, or poorly positioned chimney.
9. Adjust the draft controls so they are about 1/4" open. After you have used your **BUCK STOVE** a few times you will learn where to set the drafts to get the desired heat output.

NOTE: THE HEAT OUTPUT OF THE BUCK STOVE IS CONTROLLED BY THE DRAFT SETTING: THIS DETERMINES THE SIZE OF THE FIRE AND THE ACTUAL AMOUNT OF HEAT RELEASED.

10. In approximately 15 to 30 minutes, the blower will come on low speed. The blower will continue to operate as long as the internal temperature of the warm air chamber is above approximately 120 degrees. The warmer the stove gets, the faster the fan blows. It is controlled by a three-speed thermostat. **NOTE:** The blower is not likely to run on high speed under normal operation.

11. After several hours, the blower will begin to intermittently cycle on and off as the stove cools down. This is normal and indicates it is functioning properly.

12. When refueling your **BUCK STOVE**, first open the damper fully before opening the doors. This prevents smoke from escaping into the room. Add the desired amount of fuel, close the doors, and reposition the damper and draft controls as necessary to get the desired heat output. **First open the damper fully before opening the doors.**

13. The **BUCK STOVE** may be operated with the doors fully opened or removed. The firescreen should **ALWAYS** be in place when the stove is operated with the doors open. The firescreen is designed to lock in place when installed. **NOTE:** The handles of the firescreen are threaded to allow adjustment of the locking tabs. These should be adjusted so the firescreen is held snugly in place when the handles are rotated into the locked position.

Guide To The Different Burning Qualities of Wood

TYPE OF WOOD	EASE OF STARTING	COALING QUALITIES	AMOUNT OF SPARKS
APPLE	POOR	EXCELLENT	FEW
ASH	FAIR	GOOD	FEW
BEECH	POOR	GOOD	FEW
BIRCH	GOOD	EXCELLENT	MODERATE
CHERRY	POOR	EXCELLENT	FEW
CEDAR	EXCELLENT	POOR	MANY
ELM	FAIR	GOOD	VERY FEW
HEMLOCK	GOOD	LOW	MANY
HICKORY	FAIR	EXCELLENT	MODERATE
LOCUST	POOR	EXCELLENT	VERY FEW
MAPLE	POOR	EXCELLENT	FEW
OAK	POOR	EXCELLENT	FEW
PINE	EXCELLENT	POOR	MODERATE

The Maine Audubon Society recently charted the heat produced by a wood fire. They noted that the heat produced by a wood fire varies greatly with the kind of wood burned. Beech is considered the best wood for a fire. A cord of well-seasoned Beech will produce as much heat as 169 gallons of fuel oil. Sugar Maple and Red Oak produce as much heat as 166 gallons of fuel oil, followed by White Ash, 154; American Elm, 130; White Birch, 124; and White Pine, 94.

HOW TO COOL IT IN THE SUMMER

Empty and clean the firebox of all ashes at the end of the heating season, touch-up the exterior of the stove with an approved stove paint (spray type preferable) and you will be ready when the next heating season rolls around. You do not need to let your **BUCK STOVE** sit idle during the warm summer months. Your versatile **BUCK STOVE** will double as a cool air circulator during the summer. It's very simple.

1. Fill four containers (plastic milk containers work very well) with water and freeze.
2. Place frozen containers inside the cleaned firebox on their sides.
3. Close doors and all dampers and switch the fan to the "manual" setting. This by-passes the thermostat so the fan will run continuously.

Four one gallon frozen containers will provide reasonable cooling. Don't expect your stove to cool as well as it heats, but this is a nice, extra feature for your benefit.

COOLING A HOT STOVE

In the event that your room becomes too warm for comfort, the quickest and best way to cool your stove is to open the damper fully, open the doors, and install a firescreen. NOTE: Unplugging the blower will cause your stove to retain heat, making your room stay hotter for a longer period. Unplugging may also damage the electrical components of the stove, so never unplug the stove during use.

Your **BUCK STOVE** can burn Bituminous soft type coal only (not Anthracite) with the optional **BUCK STOVE® COAL GRATE** available at your Buck Stove dealer.

Models available:

CG-27000 for all Regular Buck Models: **27000-B** and Big Buck Model: **28000**.

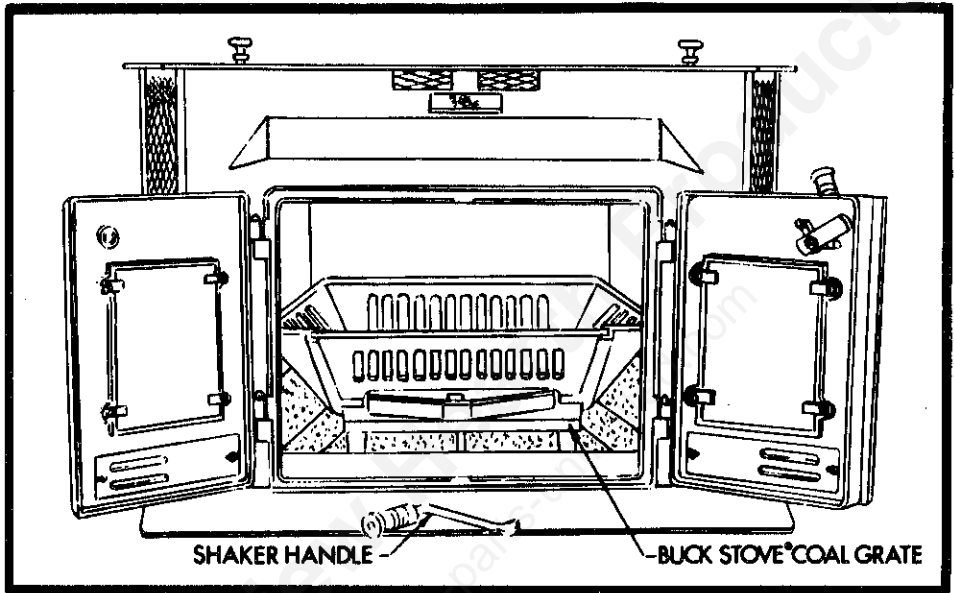

COAL GRATE AND REFRACTORY SIDE LINING

- Features include a separate stand for properly elevating grate for proper draft to fire coal. Can also be used for fire dog (andirons).
- Shaker for sifting ash.
- Shaker arm with wood handle.
- Removable basket front for ease of assembly and cleaning.

Complete assembly and read operating instructions for the **BUCK STOVE** before installing the **BUCK STOVE** Coal Grate.



CAUTION: Side Liners must be installed in the **BUCK STOVE** before installing the **BUCK STOVE** Coal Grate.

HELPFUL HINTS

CURING THE PAINT ON YOUR STOVE: During the first several firings, burn small fires to cure the paint and to prevent damage to the finish. It is a good idea to flip the toggle switch to the "MANUAL" position during these first firings so the blower will run continuously. This will allow the paint to cure at a slower rate and creates a better overall finish.

ASH BED: For maximum efficiency from your **BUCK STOVE**, allow an ash bed to build up in the stove that, in height, is approximately level with the bottom of the fire dogs. This may take several days of continued use.

CLEANING ASHES FROM YOUR STOVE: Ashes must be cleaned from the firebox through the front doors. Store the ashes in a metal container and a safe location (see safety precautions). Ashes can ignite up to 72 hours after removal.



CAUTION: Never remove ashes from your **BUCK STOVE** with the blower running. If you should accidentally lower them below the hearth across from the front of the stove, air from the lower hot air register could scatter the ashes and hot embers across your room.

CARE OF GLASS DOORS: The glass doors on your **BUCK STOVE** permit you to enjoy the beauty of the fire while retaining the efficiency of your stove. Although the brand of glass used in the **BUCK STOVE** doors has well established and recognized heat resistant and strength characteristics, it can be broken through improper use. To achieve the maximum utility and safety of your glass doors, we advise that you observe the following use and safety tips:

1. Inspect the glass regularly for cracks or breaks. If you detect a crack or break, extinguish the fire immediately and return the door to your stove dealer for glass replacement before further use.
2. Do not slam stove doors or otherwise impact the glass. When closing door, make sure that no logs or other objects protrude to impact against the glass.
3. Do not clean the glass with materials which may scratch it (such as steel wool) or otherwise damage the glass. Scratches on the glass can develop into cracks or breaks.

The glass can be cleaned with a commercial oven cleaner, providing it does not contain abrasives. A build-up on the glass that has been there for a considerable length of time can be burned off with a propane torch.

IN THE EVENT OF POWER FAILURE: Your **BUCK STOVE** can still be used as a fireplace. Open the doors, install the fire screen and continue to enjoy your **BUCK STOVE**.

NIGHTTIME USE: The fire in your **BUCK STOVE** should last throughout the night with the proper selection of firewood and controlling the rate of burn by using the draft control dampers located at the bottom of the doors.

SECTION VI



**MANUFACTURER'S SUGGESTED
PREVENTIVE MAINTENANCE**

CHECK CHIMNEY

- A. The chimney should be cleaned as necessary to remove creosote, soot, leaves, birds' nests, etc. (refer to page 50, Creosote)
- B. A neglected chimney can eventually cause a draw restriction or can ignite and burn hot enough to cause damage to the chimney.
- C. For proper inspection the chimney should be cleaned.
- D. A topper or cover should be installed to prevent moisture from entering chimney, to prevent sparks and burning materials from escaping chimney, and to keep birds and foreign materials from entering.

NOTE: Some areas may require an approved spark arrestor.

STOVE

- A. The stove should be pulled from the masonry fireplace as necessary to remove soot and ashes from around the stove.
- B. The seal of the kit to the stove and the kit to the masonry should be checked and also resealed if there is any evidence of soot, ash, or smoke leakage.
- C. Check gasketing around doors for any signs of excessive wear.

CLEANING THE STOVE

- A. The stove should not be cleaned with any type of detergent as most all detergents have an oil base and cannot be painted over.
- B. The stove should be lightly sanded with fine sandpaper or steel wool, then repainted or touched-up with high temperature black paint.
- C. If the stove is located in a moist or damp location, check thoroughly for signs of condensation during times when the stove is not in use.
- D. When the heating season is over, the stove can be cleaned out completely with a wire brush or cloth to eliminate ash and burned wood smell.

GLASS DOORS

- A. Glass doors should be handled as any other breakable glass. Heat or flames from the fire will not break the glass. However, rough handling when the glass is hot or forcing the door closed against the wood can cause breakage.
- B. Soot and smoke will cloud the glass panes very quickly when using soft wood such as pine. However, in time, this will burn off or may be cleaned with a good oven type cleaner.
- C. Check gasketing around glass for signs of deterioration.

****Most of the preventive maintenance procedures can be performed by your local **BUCK STOVE** dealer or certified **BUCK STOVE** installer****

FINAL NOTES: Fill out and mail the warranty card to the address indicated. If you have any questions concerning the operation of your **BUCK STOVE**, contact your local dealer. He will be happy to help you.

THANK YOU. We are proud to have you join our nation-wide family of satisfied **BUCK STOVE OWNERS.**

CREOSOTE — Formation and Need for Removal

When wood is burned slowly, it produces tar and other organic vapors, which combine with expelled moisture to form creosote. The creosote vapors condense in the relatively cool chimney flue of a slow-burning fire. As a result, creosote residue accumulates on the flue lining. When ignited this creosote makes an extremely hot fire.

The chimney connector and chimney should be inspected at least once every two months. More frequent inspection and cleaning may be necessary, under certain conditions of use creosote build-up may occur rapidly.

Creosote is caused by low temperatures in the chimney, which is controlled by the operator of the stove.

The damper on the stove controls the speed of the air that goes up the chimney, and the drafts in the doors govern the volume of air entering the firebox, which, in turn controls the temperature of the fire.

Many experienced wood stove operators state that having a short, 10-30 minute DAILY hot burn (accomplished by using three pieces of split, seasoned hardwood cut into chunks with a three-to-four inch diameter with the drafts and damper open) will raise the stack temperatures sufficiently to reduce excessive creosote accumulation.

Installation of the Arden Industries "Smoke Genie" catalytic system into your Buck Stove can eliminate up to 50-90% of the creosote produced during normal operation.

THERMOSTAT

After the thermostat sits dormant through an off-heating season, it may need to be operated in the manual setting a few times at the start of a new heating season to break itself in.

IMPORTANT — The following explains the significant functions of some parts in your BUCK STOVE.

THERMOSTAT — The stove is equipped with three thermostatically controlled blower speeds. Under normal operation, the blower will operate on low or medium. Whenever the blower goes into high automatically, the stove has been overfired, but can be quickly cooled by opening the damper and closing the drafts.

SIDE LINER — Reflects heat back into the fire for more complete combustion and evenly distributes the heat throughout the stove to help guard against firebox warpage.

MOTOR THERMAL-OUT — The motor is designed with a thermal overload function, which shuts off the motor automatically if it becomes overheated. This keeps the motor's electrical system safe. The motor is **not** designed to run on high speed continuously.

Mountain View Hearth Products
manuals.stove-parts-unlimited.com



BUCK STOVE WARRANTY
c/o Triple Crown Corporation
512 Cavalier Avenue
Springfield, MO 65802