

# MODEL 81 NON-CATALYTIC UNIT

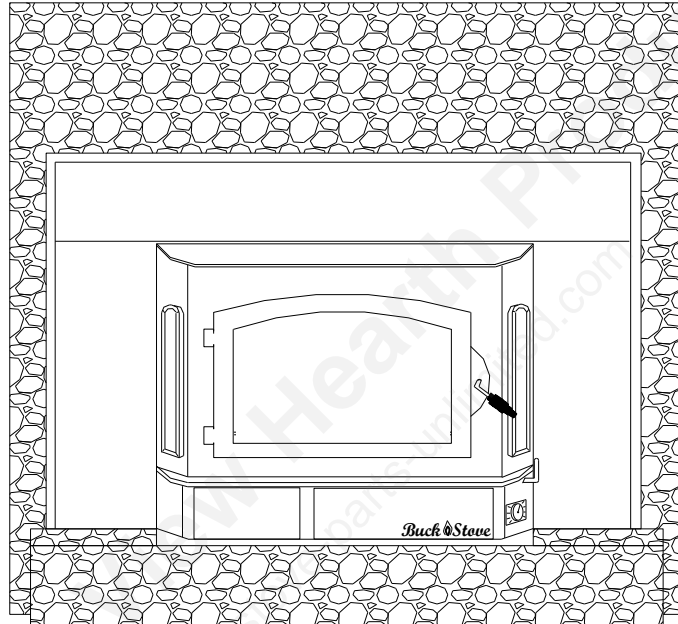

## FIREPLACE INSERT & FREESTANDING

### FEATURES

### PREPARATIONS

### INSTALLATION

### OPERATION

### MAINTENANCE

### SAFETY

## SAFETY NOTICE

**IF THIS HEATER IS NOT PROPERLY INSTALLED, A HOUSE FIRE MAY RESULT. FOR YOUR SAFETY, FOLLOW THE INSTALLATION INSTRUCTIONS. CONTACT THE AUTHORITY HAVING JURISDICTION (SUCH AS MUNICIPAL BUILDING DEPARTMENT, FIRE DEPARTMENT, FIRE PREVENTION BUREAU, etc.) CONSULT BEFORE INSTALLATION TO DETERMINE THE NEED TO OBTAIN A PERMIT. KEEP THESE INSTRUCTIONS FOR FUTURE USE.**

**TESTED AND LISTED BY:**  **ITS/WARNOCK HERSEY, MIDDLETON, WI**

**MANUFACTURED BY NEW BUCK CORPORATION  
200 ETHAN ALLEN DRIVE  
P.O. BOX 69  
SPRUCE PINE, N.C. 28777  
www.buckstove.com**

Revised January 2013

Mountain View Hearth Products  
manuals.stove-parts-unlimited.com

# TABLE OF CONTENTS

Wood Stove Description .....	2
Important Instructions .....	3
SECTION I: Introduction .....	4
SECTION II: Masonry Insert Installation.....	5
Installation Preparation-Fireplace .....	7
Mounting Trim Panels .....	9
SECTION III: Pre-Fab Insert Installation.....	12
SECTION IV: Residential Freestanding Installation.....	13
Freestanding Installation Clearances .....	21
Installation of Close Clearances Shields.....	23
SECTION V: Freestanding Mobile Home Installation.....	24
SECTION VI: Wood Heater Safety.....	29
SECTION VII: Operation .....	30
SECTION VIII: Room air blower operation .....	32
SECTION IX: Troubleshooting.....	33
Parts List .....	34
Warranty .....	35

# EPA COMPLIANCE STATUS

The Model 81 heater meets U.S. Environmental Protection Agency's Emission limits for wood heaters sold after July 1, 1992. Under specific conditions this heater has been shown to deliver heat at rates ranging from approximately 10,000 to 45,000 BTU/hr for the Model 81.

# MODEL 81 WOOD STOVE

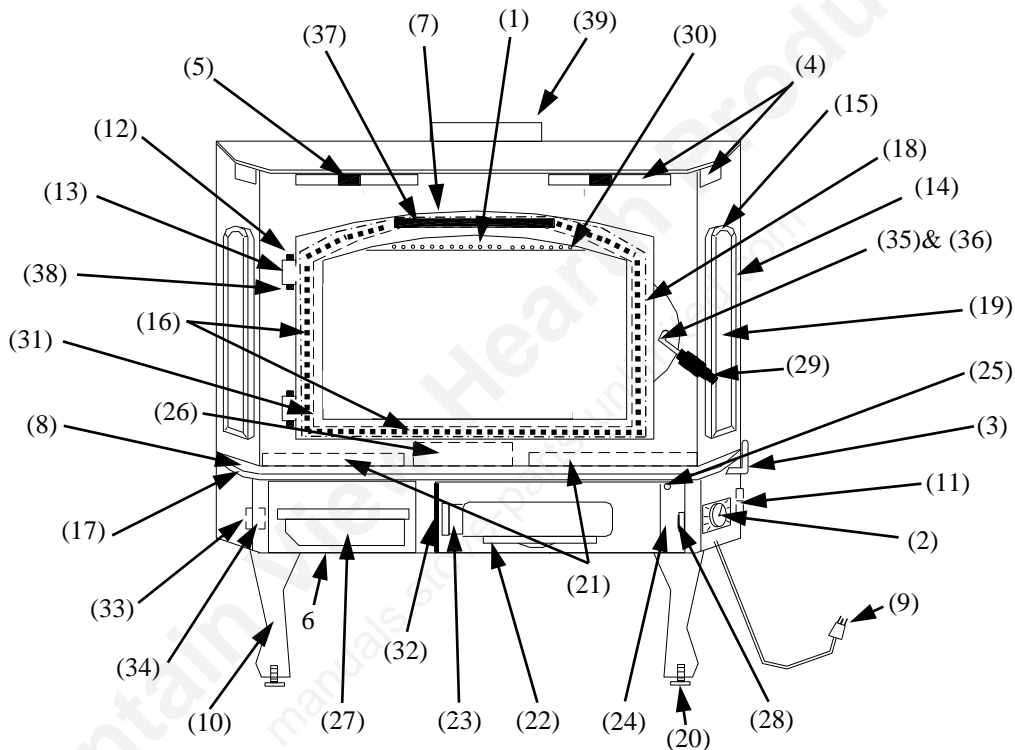

- |                                |                                   |                                       |
|--------------------------------|-----------------------------------|---------------------------------------|
| 1. Secondary air tubes         | 15. Brass overlay mounting screws | 28. Disc thermostat                   |
| 2. Blower control (rheostat)   | 16. Glass clips                   | 29. Door handle & brass spring handle |
| 3. Primary air control         | 17. Hearth Brass                  | 30. Air wash screen                   |
| 4. Warm air outlets            | 18. Door Gasket                   | 31. Glass gasket                      |
| 5. Baffles (interior of stove) | 19. Side glass                    | 32. Cover door hinge                  |
| 6. Air inlet                   | 20. Leveling screws               | 33. Magnet holder                     |
| 7. Door                        | 21. Firebrick                     | 34. Cover door Magnet                 |
| 8. Hearth extension            | 22. Motor                         | 35. Door latch                        |
| 9. Power cord                  | 23. Motor mount bracket           | 36. Door latch screw                  |
| 10. Legs                       | 24. Cover Door                    | 37. Top Baffle Board                  |
| 11. Automatic/off/man. switch  | 25. Cover door screws             | 38. Hinge pins                        |
| 12. Brass cap                  | 26. Shot gun air box              | 39. 6" Flue exit                      |
| 13. Hinge Block                | 27. Ash pan                       |                                       |
| 14. Brass overlays             |                                   |                                       |

# INSTALLATION, OPERATION, AND MAINTENANCE INSTRUCTIONS MODEL 81

READ THIS FIRST

## IMPORTANT INSTRUCTIONS

### WARNING

THESE UNITS GENERATE A LOT OF HEAT, SO TREAT THEM WITH CARE. **HOT WHILE IN OPERATION.** KEEP CHILDREN, CLOTHING AND FURNITURE AWAY. CONTACT MAY CAUSE SKIN BURNS. READ ALL INSTRUCTIONS BEFORE INSTALLING AND USING THE APPLIANCE. FAILURE TO FOLLOW INSTRUCTIONS MAY RESULT IN PROPERTY DAMAGE, BODILY INJURY OR EVEN DEATH. SAVE THESE INSTRUCTIONS FOR FUTURE REFERENCES.

- The New Buck Corporation non-catalytic system has been tested by Intertek Testing Services, Warnock Hersey to ANSI/UL Standards :UL 1482 (1996) :UL 1482 (200) :UL 1482 (2006) :UL 1482 (2010).
- Install and operate your units according to instructions provided in this manual. Local building codes may apply; therefore, contact your local building inspector or fire marshal for necessary installation requirements and permits which may go beyond these instructions.
- If appliance is installed in mobile homes:  
**DO NOT INSTALL IN SLEEPING ROOMS.**
- NOTE: When burning any unit or appliance that combusts fuel for heat, such as coal, oil, wood or natural and (L.P.) liquid petroleum gas, we highly recommend the use of smoke and carbon monoxide detectors in your home.
- Examine masonry fireplace and chimney prior to installation of fireplace accessory to determine that construction meets minimum fireplace construction requirements illustrated in instructions, that it is free from cracks, loose mortar, creosote deposits and other blockage or other signs of deterioration.

### CAUTION

DO NOT USE MORE THAN ONE STOVE TO A CHIMNEY. DO NOT USE A FLUE INTENDED FOR A GAS APPLIANCE. DO NOT CONNECT THIS UNIT TO A CHIMNEY FLUE SERVING ANOTHER APPLIANCE. DO NOT CONNECT TO ANY AIR DISTRIBUTION DUCT OR SYSTEM.

- A factory-built pre-fabricated chimney may be used for your units when installed in compliance with manufacturer's specification and uniform building code.

## CAUTION

YOUR CHIMNEY MUST BE CORRECTLY SIZED. A CHIMNEY THAT IS TOO SMALL OR LARGE IN DIAMETER, OR TOO SHORT, CAN CAUSE YOUR STOVE TO SPILL SMOKE WHEN THE DOOR IS OPENED.

## SECTION I

### INTRODUCTION

Your Buck Stove is non-catalytic unit designed to meet the most stringent emissions standards without the use of a catalytic combustor. This effect is achieved through the use of a secondary air which is mixed with primary air in unit's firebox.

For peak performance, we suggest the use of natural seasoned hard wood, loading wood from front to rear.

**NOTE: Soft woods such as pine, create more creosote, clogging of chimney and produce a less efficient burn performance.**

You should not burn trash or garbage, artificial or paper logs, gift wrapping, treated or painted wood or any type of coal or flammable fluids.

The primary air, which is controlled by the user, burns the wood. Secondary air is admitted into firebox through secondary air tubes at top of firebox. This secondary air burns impurities in smoke released from the initial wood burning. The temperature necessary for this combustion is maintained through the firebrick refractory. If any more technical information is necessary, contact your local dealer.

This heater is equipped with a standard room air blower. For operation and use of these electrical assemblies, see instructions provided in this manual starting on page 30.

## SECTION II

### MASONRY INSERT INSTALLATION

The Model 81 may be installed using an all masonry fireplace built in accordance with the Uniform Building Code and National Fire Protection Association (NFPA). The first step in this type of installation is to determine acceptability of fireplace and chimney for use with a woodstove. Both construction and condition of fireplace are important considerations when installing a woodstove. The chimney should extend at least 3' above roof and at least 2' above any point of roof within 10'.

### CAUTION

REMEMBER TO HAVE YOUR CHIMNEY INSPECTED FOR LEAKS AND BLOCKAGE BEFORE YOU INSTALL YOUR STOVE. DO NOT CONNECT THIS UNIT TO A CHIMNEY FLUE SERVING ANOTHER APPLIANCE.

### MINIMUM CLEARANCE MASONRY INSERT

#### MODEL 81

A. Side Wall Combustible	12"
B. Front Floor Protector	16"
C. Side Floor Protector	8"
D. Side Wood Trim	7"
E. Top Wood Trim	10"
F. Mantel or Brackets	21"

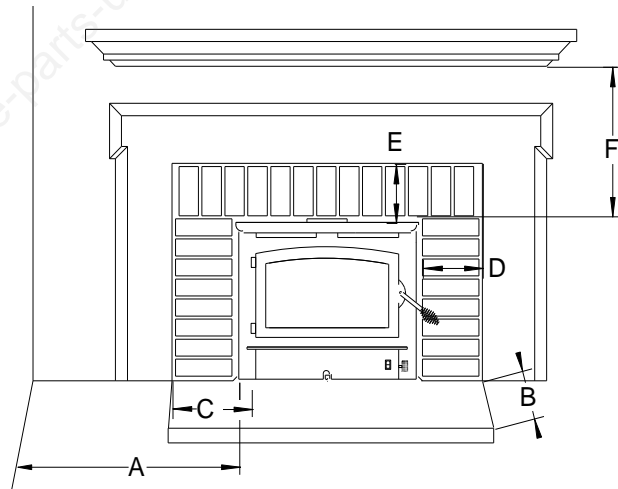

1. The hearth must be of masonry construction and must extend a minimum of 16" in front of firebox opening and a minimum of 8" to either side of firebox opening.
2. If there is not minimum hearth protection from front of firebox opening and front of masonry hearth, a floor protector must be used in front of hearth to protect combustible materials. The floor protector must be 3/8" minimum thickness non-combustible material or equivalent.(See Page 6).

# MINIMUM CLEARANCES

## Floor Protection:

When installing freestanding heater, a floor protector must be use. Floor protector must be 3/8” minimum thickness non-combustible material or equivalent.

### How to use alternate materials and how to calculate equivalent thickness

An easy means of determining if a proposed alternate floor protector meets requirements listed in the appliance manual is to follow this procedure:

1. Convert specification to R-value:
  - R-value is given—no conversion is needed.
  - K-factor is given with a required thickness (T) in inches:  
C-factor is given:  $R=1/C$
2. Determine the R-value of the proposed alternate floor protector.
  - Use the formula in step (1) to convert values not expressed as “R”
  - For multiple layers, add R-values of each layer to determine the overall R-value.
3. If the overall R-value of the system is grater than the R-value of the specified floor protector, the alternate is acceptable.

#### Example:

The specified floor protector should be 3/4” thick material with a K-factor of 0.84.  
The proposed alternate is 4” brick with a C-factor of 1.25 over 1/8” mineral board with a K-factor of 0.29.

Step (a): Use formula above to convert specification to R-value.  $R= 1/K \times T = 1/0.84 \times .75 = 0.893$

Step (b): Calculate R of proposed system. 4” brick of  $C=1.25$ , therefore  $R_{brick} = 1/C = 1/1.25 = 0.80$  1/8” mineral board of  $K = 0.29$ , therefore  $R_{min.bd.} = 1/0.29 \times 0.125 = 0.431$

Step (c): Compare proposed system R of 1.231 to specified R of 0.893. Since proposed system R is greater than required , the system is acceptable.

#### Definitions:

$$\text{Thermal conductance} = C = \frac{\text{Btu}}{(\text{hr})(\text{ft}^2)(\text{°F})} = \frac{\text{W}}{(\text{m}^2)(\text{°K})}$$

$$\text{Thermal conductance} = K = \frac{(\text{Btu})(\text{inch})}{(\text{hr})(\text{ft}^2)(\text{°F})} = \frac{\text{W}}{(\text{m})(\text{°K})} = \frac{(\text{Btu})}{(\text{hr})(\text{ft})(\text{°F})}$$

$$\text{Thermal conductance} = R = \frac{(\text{ft}^2)(\text{hr})(\text{°F})}{\text{Btu}} = \frac{(\text{m}^2)(\text{°K})}{\text{W}}$$

Install in accordance with 24 CFR, Part 3280 (HUD).

## POSSIBLE TOOLS NEEDED FOR INSTALLATION

If you decide to install your own stove, there are several hand tools you may need to do the job. If you do not already have them, they are readily available at most hardware stores.

Caulking gun

Large adjustable wrench (may not be needed)

Drop cloths or newspapers

Vacuum cleaner or whisk broom

Flashlight

1 tube of RTV silicone, Code 103 or 106, or high temperature rubber cement rated between 450° F- 600° F

7/32" drill bit and drill

Socket/Ratchet Set

## INSTALLATION PREPARATION

### Fireplace:

1. Relocate furniture and other materials away from front of fireplace to allow free access to fireplace.
2. Cover hearth and adjacent floor areas with a drop cloths to protect from soiling or marring surface.
3. Remove existing fireplace damper plate.
4. Thoroughly clean fireplace of ashes and soot.
5. Check chimney and smoke chamber for excessive buildup of creosote or soot. Also, check for obstructions, such as birds nests. If chimney is excessively dirty, clean it or have someone clean it professionally BEFORE installing or using room heater.
6. If fireplace has an ash dump or outside air provision, these must be sealed off with metal or tightly packed non-combustible insulation to prevent cold air from entering fireplace chamber.

---

## MASONRY INSERT INSTALLATION INSTALLATION OPTIONS

This unit (appliance) may be installed into an all masonry fireplace, built in accordance with Uniform Building Code and National Fire Protection Association (*NFPA 211*).

**NOTE:** Check with local building officials for any permits required for installation of this unit and notify your insurance company before proceeding with installation.

In cases, such as improperly drawing fireplaces, oversize flue liners are to meet codes in certain areas it is recommended that one of the following procedures be followed:

- A. A **Chimney Connector** can be installed from appliance flue exit through damper, plus a air-tight face seal. See option (A) page 8.
- B. A listed **Direct Connect** can be installed from appliance flue exit through damper, into first section of flue liner with air-tight seal. See option (B) page 8.
- C. A **Positive Connect** can be installed from appliance flue exit continuing up through entire chimney and exiting at top of chimney. See option (C) page 8.

**! SAFETY NOTICE**

**If this appliance is not properly installed, a house fire may result. For your safety, follow the installation directions. Contact local building or fire officials about restrictions and installation inspection requirements in your area.**

**OPTION (A)**

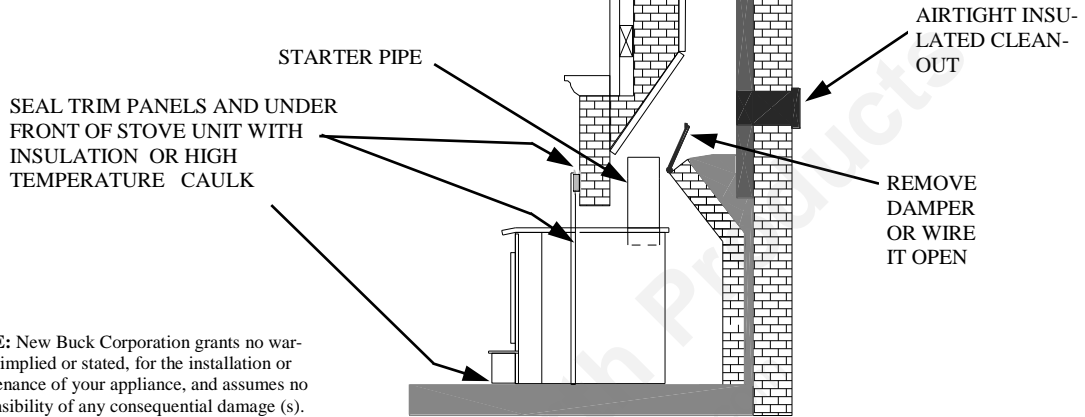

**NOTE:** New Buck Corporation grants no warranty, implied or stated, for the installation or maintenance of your appliance, and assumes no responsibility of any consequential damage (s).

**OPTION (B)**

**NOTE:** Follow installation instruction with Direct Connection Kit. (Kit sold separately)

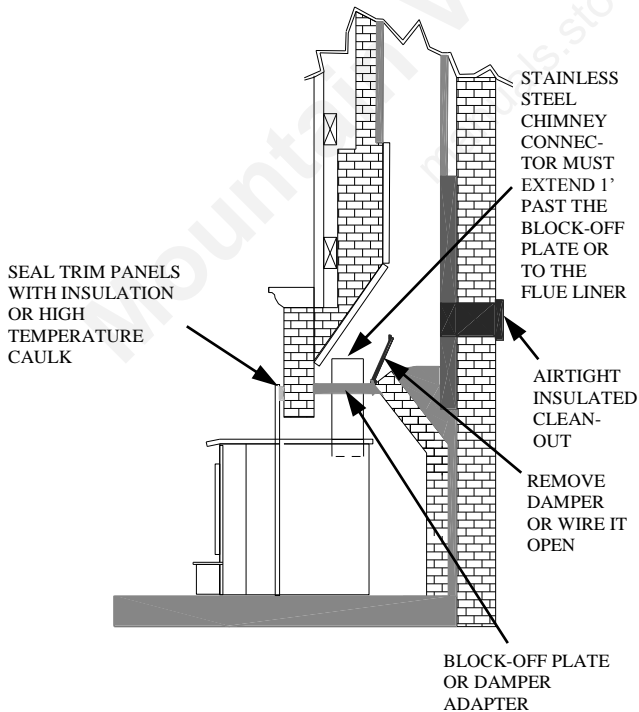

**OPTION (C)**

**NOTE:** Follow installation instruction with Positive Connection Kit. (Kit sold separately)

INSTALL A NON-COMBUSTIBLE COVER PLATE TO PREVENT WATER FROM ENTERING THE CHIMNEY

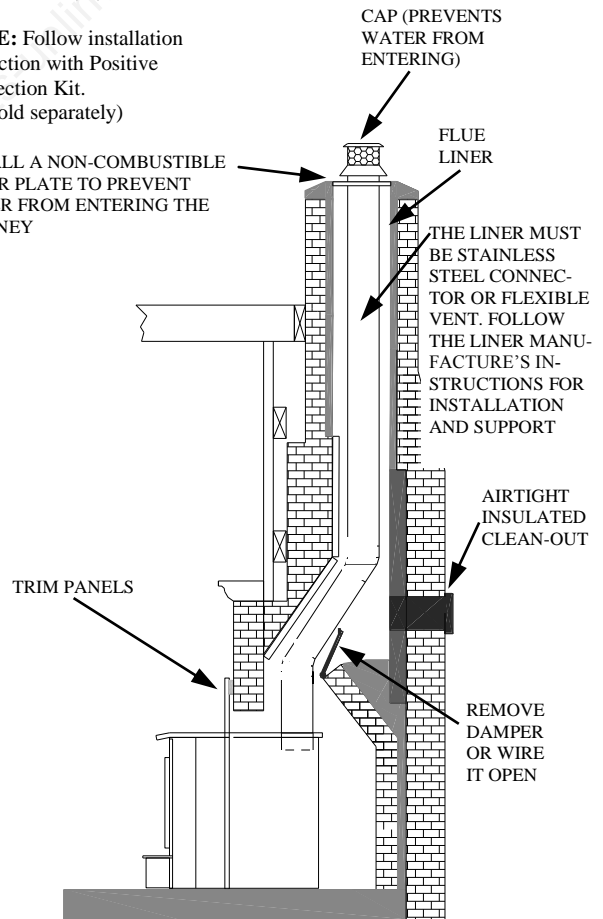

# INSTALLATION PROCEDURE

(Use a chimney connector or a Listed Direct or Positive Connect) (See Page 8.)

## POSITIONING HEATER

When positioning heater, the following conditions **MUST** be met! (See Figure 2).

1. The front of damper opening must be positioned **BEHIND** back edge of lintel to ensure proper draft. (See Figure 2).
2. Center heater in the fireplace opening.

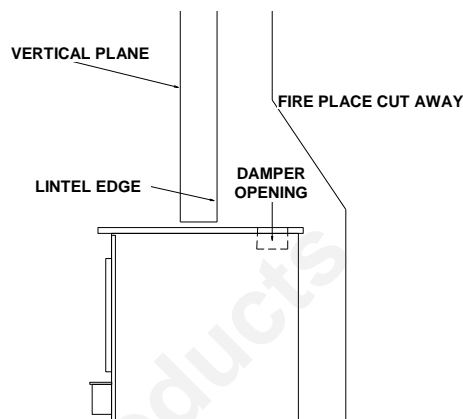

FIGURE 2 POSITIONING

## MOUNTING TRIM PANELS

After unit is positioned, mark mounting position of trim panels as follows:

1. Place side trim panels flat against face of fireplace. Mark front edge of trim panel with a pencil to make a vertical reference line. (See Figure 3).
2. Place top (long) trim panel on top of unit. The panel should be flat against the outside face of fireplace and standing vertically. Mark along lower edge of trim panel with a pencil to make a reference line for mounting.
3. Slide unit out of fireplace far enough to work behind trim panel reference lines.
4. Mount side trim panels. (See Figure 3).
  - a. Position side trim panel on reference line.
  - b. Drill mounting holes in center of side trim panel mounting brackets to allow for adjustment in and out if necessary.
  - c. Mount trim panel using self-tapping screws provided.
5. Place top trim panel on reference mark. Top trim panel mounting bracket (supplied) must overlap rear lip of top trim panel. Drill mounting holes in top of stove using holes in bracket as guide. Tighten screws.
6. Follow installation procedures in listed direct connect or positive connect kit you are using and install heater connect kit in fireplace. If not using one of installation methods shown on Page 8, continue.
7. Slide unit back into fireplace. Check to be sure that trim panels are properly positioned and lie flat against front of fireplace. If one or more of panels is out of position, slide unit out and reset by loosening mounting screws and repositioning in slot.
8. Reinstall top trim panel by sliding rear lip of top trim panel underneath front lip of mounting bracket already secured to top of unit.

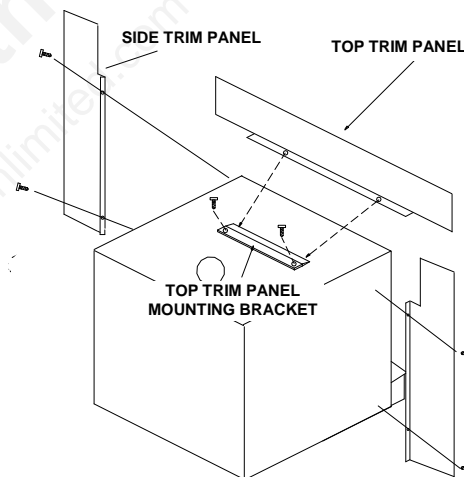
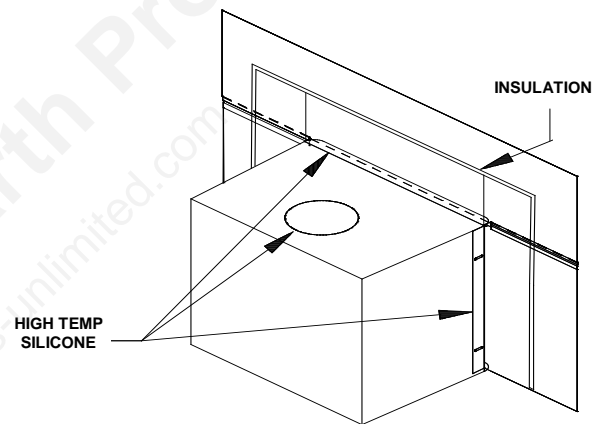
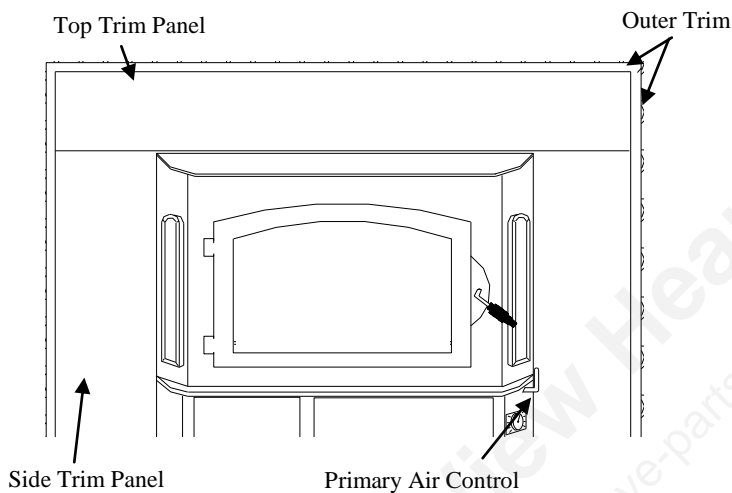

FIGURE 3 MOUNTING TRIM PANELS

- NOTE:** Mount top trim panel so that it sits in front of top of side trim panels.
9. Obtain brass trim kit provided with insert kit and slip over top and sides of trim panels. Top ends of brass may need to be trimmed to fit (See Figure 4).
  10. Using insulation provided, peel and stick to back of panels overlapping fireplace dimensions by 1" on each side and top. (See Figure 4A).
  11. Next using high heat silicone or furnace cement run heavy bead of caulking around where panels meet the stove. (See Figure 4A).
  12. Slide unit back into fireplace. Check to be sure that trim panels (and brass) are properly positioned and lie flat against front of fireplace. If panels are out of position, slide unit out and reset by loosening mounting screws and repositioning in slot. Using the bar, lift stove up in front. Place insulation across front and surface of hearth or bottom of fireplace to make complete seal.
  13. To check seal of panels, use candle flame and go around entire area sealed by silicone and insulation. If flame leans toward inside of fireplace, add additional insulation. This ensures an airtight seal.



## FINAL CHECK

FIGURE 4

FIGURE 4A

1. Recheck specified clearances.
2. Remove all foreign material from firebox area.
3. **Primary Air Control:** The primary air intake draft control is located at right bottom side of hearth. It is operated by moving handle **out** to open (to allow air into the firebox) or **in** to control or close off air into firebox. (See Figure 4).
4. Plug power cord into a 115V AC outlet if optional motor is being used. "Do not run power cord under unit or in high traffic areas.
5. Place crumpled pieces of newspaper in stove. Light it and close door. Ensure that stove draws properly through primary draft.

**NOTE: Do not use grate or elevate fire. Build wood fire directly on inner bottom of fire box.**

6. Check for smoke leaks around door.
7. Open door and check for smoke escaping from front of stove. Smoking usually indicates a defective or poorly positioned chimney. Some chimneys with a marginal draft can be pre-heated by lighting newspaper and holding it near open damper with a poker or fire tong. Once chimney heats up, a proper draft can usually be obtained.

If a thorough review of Troubleshooting Guide in the manual does not reveal problem, contact your dealer for assistance.

## CAUTION

**THE UNIT IS PAINTED WITH A SPECIALLY FORMULATED HIGH TEMPERATURE PAINT THAT CURES DURING THE FIRST TWO OR THREE FIRINGS. YOU MAY NOTICE A SLIGHT SMOKING EFFECT AND AN ODOR OF BURNING PAINT WHEN YOU BUILD THE FIRST FIRES. THIS IS NORMAL AND IS NOT A CAUSE FOR ALARM. IN SOME CASES, THESE FUMES WILL ACTIVATE A SMOKE ALARM. OPENING A WINDOW NEAR THE UNIT WILL ALLOW THESE FUMES TO ESCAPE. DO NOT BUILD A LARGE, ROARING FIRE UNTIL THIS CURING IS COMPLETE OR HEATER FINISH MAY BE DAMAGED.**

The connector and/or chimney should be inspected at least once a month during heating season to determine if a creosote buildup has occurred.

## CAUTION

**NEVER USE GASOLINE, GASOLINE-TYPE LANTERN FUEL, KEROSENE, CHARCOAL LIGHTER FLUID OR SIMILAR LIQUIDS TO START OR "FRESHEN UP" A FIRE IN THE HEATER. KEEP ALL SUCH LIQUIDS WELL AWAY FROM THE STOVE WHEN IT IS IN USE. ALL FLUIDS OF THIS TYPE GIVE OFF VOLATILE FUMES AND CAN AND WILL EXPLODE! DON'T TAKE A CHANCE WITH THE SAFETY OF YOUR HOME AND FAMILY.**

## SECTION III

### PRE-FAB INSERT INSTALLATION

The Model 81 may be installed into any UL listed pre-fabricated fireplace that is large enough to accept it.

**NOTE:** When installing Model 81 into a Pre-Fab Zero-Clearance fireplace, a UL-1777 LINER must be installed the Full Length of chimney and attached to flue exit of insert.

**NOTE:** The ash lip, smoke baffle and smoke shelf of pre-fab fireplace may be removed if necessary to provide room for these models. Any other alteration to unit will void ALL New Buck Corporation responsibility and liability. The warning label below must be attached to back of fireplace.

**NOTE:** Plug power cord into a 115V AC outlet. Set switch to “Manual” and rheostat to “High” position to ensure motor operates properly. Route power cord to prevent damage to cord insulation from heat and sharp objects. Keep cord out of way of traffic to prevent damage caused by tripping, etc.

**NOTE:** DO NOT BLOCK ANY EXISTING LOUVERS OR VENTS ON EXISTING PRE-FAB WITH ANY TRIM PANELS FOR MODEL 81.

Except for “notes” above, please follow instruction of masonry installation, Section II.

Instruction

Minimum clearances for stove

Minimum clearances for floor protector

**WARNING:** This fireplace must be restored to it’s original condition for safe use if the fireplace insert is removed.

## SECTION IV

# RESIDENTIAL FREESTANDING INSTALLATION

Select an installation location that will give best airflow from front of heater to remainder of home.

### PREPARING STOVE FOR INSTALLATION

1. Inspect unit for any obvious physical damage.
2. Plug power cord into a 115V AC outlet to test motor and fan. Do not run cord under unit or in high traffic areas.
3. Check primary air draft control to ensure that it slides freely. (See Figure 5).
4. Remove any items from within firebox. Spread a dropcloth on floor behind heater. Next, tilt heater so that back is on drop cloth.
5. **(Leg Kit):** If legs are to be used, obtain four legs, attach legs to holes in bottom of unit with bolts and washers supplied with leg kit. (See Figure 5).
6. **(Pedestal Kit):** If pedestal kit is being used an outside air is required for residential free standing installation (page 25 Out Side Air Installation). Open freestanding kit and obtain stand. Place stand against bottom of heater (angle side to heater). Center stand front to rear and also center stand left and right. Mark screw locations on bottom of stove through outer holes of stand mounting angles. Set stand aside and drill four 7/32" holes in heater bottom. Then mount stand to bottom of heater with screws provided. (See Figure 5A).
7. Obtain four (4) 3/16" self-tapping screws and secure stand to heater.
8. Reposition heater to upright position.

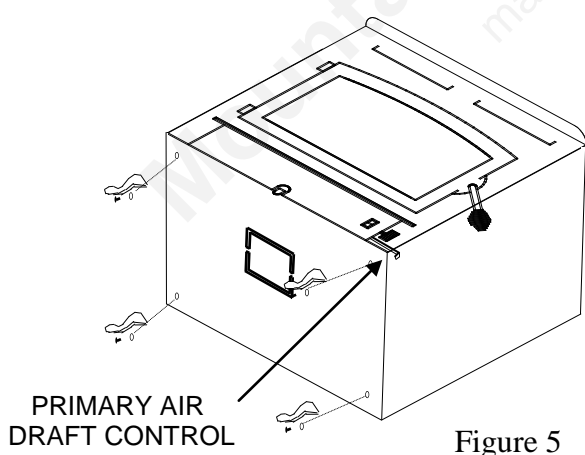

Figure 5

#### HOLES FOR MOUNTING PEDESTAL

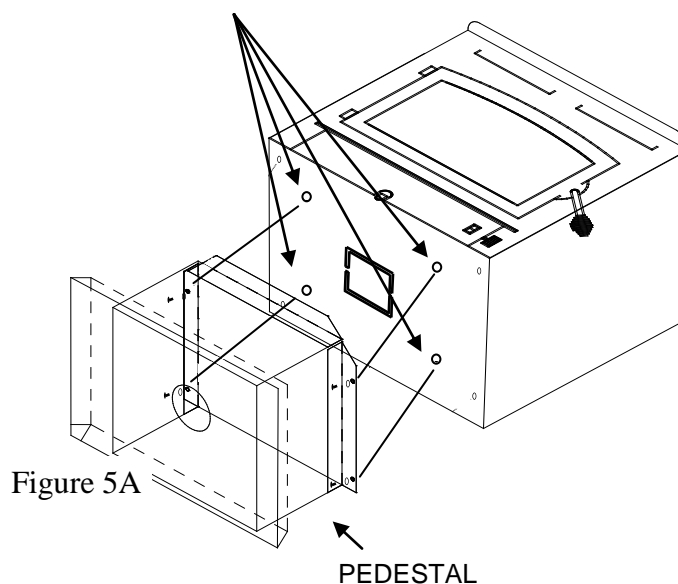

Figure 5A

# ALTERNATE FLOOR PROTECTORS MATERIAL

## Floor Protection:

When installing freestanding heater, a floor protector must be use. Floor protector must be 3/8” minimum thickness non-combustible material or equivalent.

### How to use alternate materials and how to calculate equivalent thickness

An easy means of determining if a proposed alternate floor protector meets requirements listed in the appliance manual is to follow this procedure:

1. Convert specification to R-value:
  - R-value is given—no conversion is needed.
  - K-factor is given with a required thickness (T) in inches:  
C-factor is given:  $R=1/C$
2. Determine the R-value of the proposed alternate floor protector.
  - Use the formula in step (1) to convert values not expressed as “R”
  - For multiple layers, add R-values of each layer to determine the overall R-value.
3. If the overall R-value of the system is grater than the R-value of the specified floor protector, the alternate is acceptable.

#### Example:

The specified floor protector should be 3/4” thick material with a K-factor of 0.84.

The proposed alternate is 4” brick with a C-factor of 1.25 over 1/8” mineral board with a K-factor of 0.29.

Step (a): Use formula above to convert specification to R-value.  $R= 1/K \times T = 1/0.84 \times .75 = 0.893$

Step (b): Calculate R of proposed system. 4” brick of  $C=1.25$ , therefore  $R_{brick} = 1/C = 1/1.25 = 0.80$  1/8” mineral board of  $K = 0.29$ , therefore  $R_{min.bd.} = 1/0.29 \times 0.125 = 0.431$

Step (c): Compare proposed system R of 1.231 to specified R of 0.893. Since proposed system R is greater than required , the system is acceptable.

#### Definitions:

$$\text{Thermal conductance} = C = \frac{\text{Btu}}{(\text{hr})(\text{ft}^2)(\text{°F})} = \frac{\text{W}}{(\text{m}^2)(\text{°K})}$$

$$\text{Thermal conductance} = K = \frac{(\text{Btu})(\text{inch})}{(\text{hr})(\text{ft}^2)(\text{°F})} = \frac{\text{W}}{(\text{m})(\text{°K})} = \frac{(\text{Btu})}{(\text{hr})(\text{ft})(\text{°F})}$$

$$\text{Thermal conductance} = R = \frac{(\text{ft}^2)(\text{hr})(\text{°F})}{\text{Btu}} = \frac{(\text{m}^2)(\text{°K})}{\text{W}}$$

Install in accordance with 24 CFR, Part 3280 (HUD).

## Chimney

This model is designed for connection to any listed 2100° UL103 HT chimneys and parts. Follow chimneys manufacturer's instructions carefully.

**NOTE:** This Room Heater must be converted to (1) a chimney complying with requirements for Type HT chimneys in Standard forchimneys, Factory-Built, Residential, Type and Building Heating Appliance, UL 103, or (2) a code approved masonry chimney with a flue liner. The chimney size should not be less than nor more than 3 times greater than cross-sectional area of flue collar.

### CAUTION

**SPECIAL METHODS ARE REQUIRED WHEN PASSING THROUGH A WALL OR CEILING. SEE INSTRUCTIONS AND BUILDING CODES.**

### DETERMINING CHIMNEY LOCATION

**A. Ceiling Exits: (Using 6" Single Wall Pipe and UL 103 HT type chimney system listed with manufacturer in this section of manual).**

1. Suspend a plumb bob from ceiling above unit so weight is hanging in center of flue exit. (A small weight on a string will serve as a plumb bob). Mark ceiling where string is suspended to locate center of chimney.
2. After locating center of hole, install ceiling support box, chimney, flashing and rain cap, per chimney manufacturer's instructions.
3. Now connect stove and ceiling support box using #24 ga. minimum blued or black steel connector pipe. **(DO NOT USE GALVANIZED PIPE)**. Connect each section so crimped end faces downward and secure each section to each other using at least

three (3) sheet metal screws or rivets. Next, install an optional New Buck Corporation chimney connector to flue exit of heater. (See Figure 6).

4. Install Single Wall Connector and chimney system, per manufacturer's written operating instructions. See manufacturer's list of tested pipes in this manual.

Figure 6

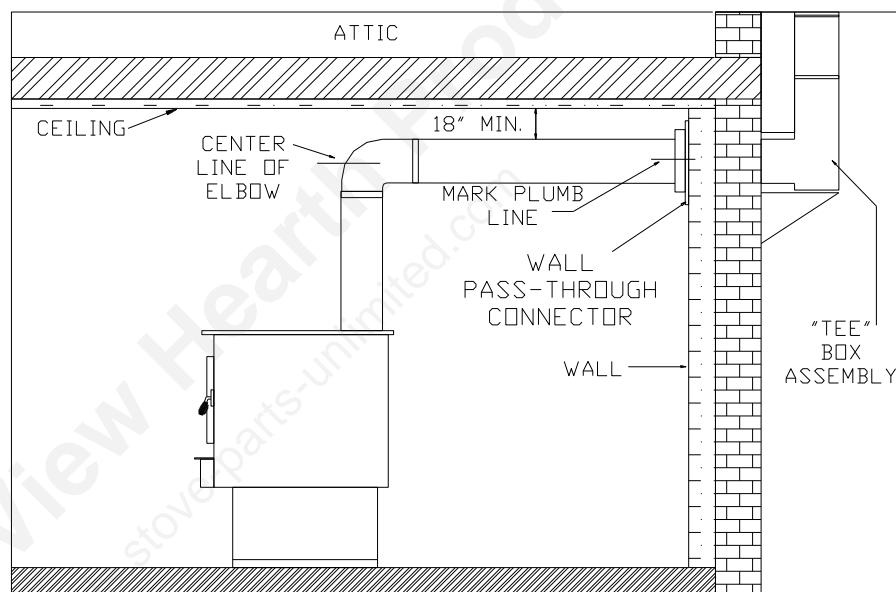
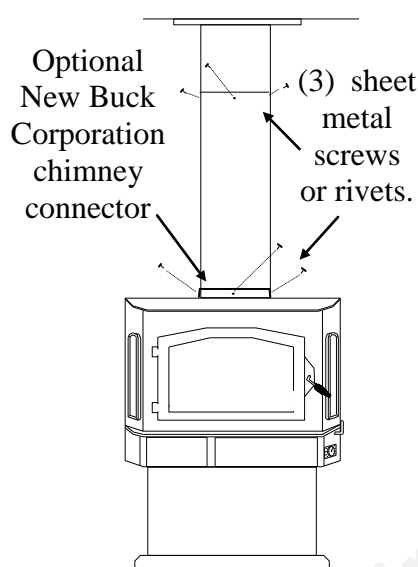

Figure 7

### B. Wall Exit Into Metal Tee-Box

1. Mark the plumb line on wall directly behind center of heater. (See Figure 7).

**NOTE:** When using #24 ga. minimum blue or black steel pipe maintain 18" between pipe and ceiling.

2. Place vertical portion of heater pipe and elbow in position and project a point onto plumb line level with center of the elbow.
3. Measure up so there will be at least 1/4" rise per foot of horizontal connector pipe.

maintaining clearances to ceiling as noted in Figure 7. This will give you center of hole for chimney penetration.

4. After locating center of penetration, install tee box and chimney, per chimney manufacturer's specifications.
5. Connect chimney collar to tee-box using #24 ga. minimum blued or black steel connector pipe. **(DO NOT USE GALVANIZED PIPE)**. Connect each section so crimped end faces downward and secure each section to each other using three (3) sheet metal screws or rivets.

### C. Wall Exit Into Masonry (Using Single Wall Pipe)

1. Before connecting this unit to a masonry chimney, determine that masonry fireplace wall pass through connector thimble meets **NFPA-211** Code and local building codes and is a minimum of 18" from ceiling. If connector thimble does not meet these codes, the pass through connector must be modified. (See Figure 8).

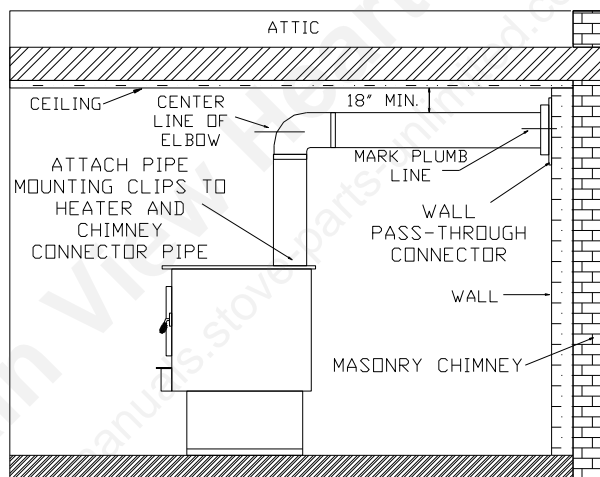

Figure 8

Connectors may pass through walls or partitions constructed of combustible material if connector is:

- (a) Either listed for wall pass through or is routed through a device listed for wall pass through and is installed in accordance with conditions of listing.
- (b) Selected or fabricated in accordance with conditions and clearances as stated in **NFPA-211** Code. Any unexposed metal that is used as part of a wall pass through system and is exposed to flue gases shall be constructed of stainless steel or other equivalent material that will resist corrosion, softening, or cracking from flue gases at temperatures up to 1800° F.

**NOTE:** In addition, a connector to a masonry chimney shall extend through wall to inner face or liner but not beyond and shall be firmly cemented to masonry.

**EXCEPTION:** A thimble may be used to facilitate removal of chimney connector for cleaning, in which case, thimble shall be permanently cemented in place with high-temperature cement.

2. Once through-the-wall thimble codes are met, simply connect chimney collar to wall pass through connector using #24 ga. minimum, blued or black steel connector pipe as follows:
  - (a) Maintain 1/4" rise per foot (horizontal length) from appliance to chimney.
  - (b) Connect each section so crimped end faces downward or back toward unit.
  - (c) Secure each section to each other using at least three (3) sheet metal screws or rivets.
  - (d) Use three (3) sheet metal screws to fasten pipe to connector collar on heater.

#### **D. Ceiling Exit-Close Clearance**

1. Suspend a plumb bob from ceiling above unit so that weight is hanging in center of flue exit. (A small weight on a string will serve as a plumb bob). Mark ceiling where string is suspended to locate center of chimney hole.
2. After locating center of hole, install ceiling support box, chimney flashing and rain cap.
3. Now connect stove and ceiling support box using #24 ga. minimum blued or black steel connector pipe. (**DO NOT USE GALVANIZED PIPE**). Connect each section so crimped end faces downward and secure each section to each other using at least three (3) sheet metal screws or rivets. Next, install an optional New Buck Corporation chimney connector to flue exit of heater or you may use "Ell" brackets to fasten pipe to stove.
4. Install Single Wall Connector and chimney system, per manufacturer's written operating instructions. See manufacturer's list of tested pipes in this manual.

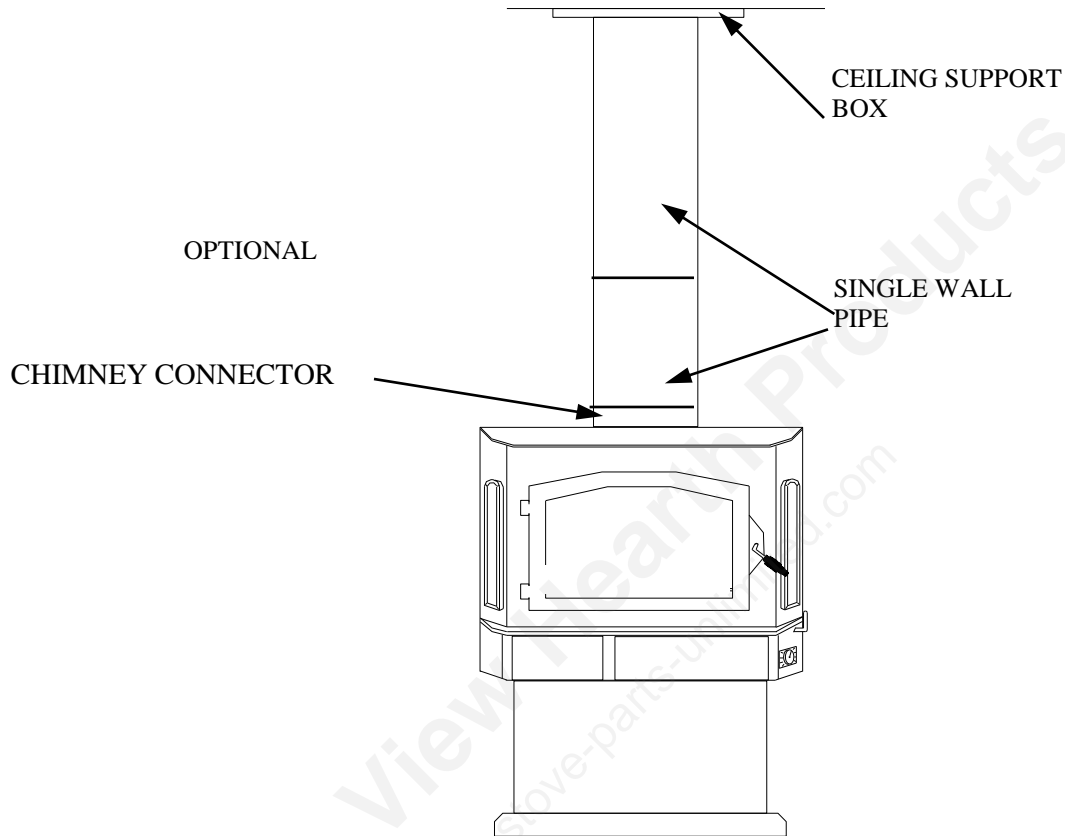

Figure 8

Close Clearance Installation using: **(1)** 6" Simpson Dura-Vent single wall chimney connector Dura Black and 6" Simpson Dura-Vent 2100 Deg Ht. "Type DP" chimney. **(2)** 6" Metal Fab Type single wall connector- 6" Metal Fab 2100 HT chimney. **(3)** 6" Ameritec single wall connector - 6" Ameritec 2100 degree HT chimney . For minimum clearances see pages 21 & 22.

### ALCOVE INSTALLATION CLEARANCES

Must use 6" Single Wall Connector and 6" Type HT Pipe listed for close clearance reduction listed in this manual. For minimum clearances see pages 21 & 22. Must also use close clearance shield kit.

## FINAL CHECK

1. Recheck specified clearances.
2. Remove all foreign material from firebox area.
3. Open primary air draft.

**NOTE:** Plug power cord into a 115V AC outlet. Set switch to “Manual” and rheostat to “High” position to ensure motor operates properly. Route cord to prevent damage to cord insulation from heat and sharp objects. Keep cord out of way of traffic to prevent damage caused by tripping, etc.

4. Place crumpled pieces of newspaper in stove. Light it and close door. Ensure that stove draws properly through primary draft.
5. Check for smoke leaks around door.

### CAUTION

**Open door and check for smoke escaping from front of stove. Smoking usually indicates a defective or poorly positioned chimney. Some chimneys with a marginal draft can be pre-heated by lighting newspaper and holding it near open damper with a poker or fire tong. Once the chimney heats up, a proper draft can usually be obtained.**

If a thorough review of the Troubleshooting Guide in manual does not reveal problem, contact your dealer for assistance.

### CAUTION

**The unit is painted with a specially formulated high temperature paint that cures during the first two or three firings. You may notice a slight smoking effect and an odor of burning paint when you build first fires. This is normal and is not a cause for alarm. In some cases, these fumes will activate a smoke alarm. Opening a window near unit will allow these fumes to escape. DO NOT build a large, roaring fire until this curing is complete or heater finish may be damaged.**

# CLEARANCES FOR MODEL 81 MINIMUM CLEARANCES TO COMBUSTIBLES FREESTANDING

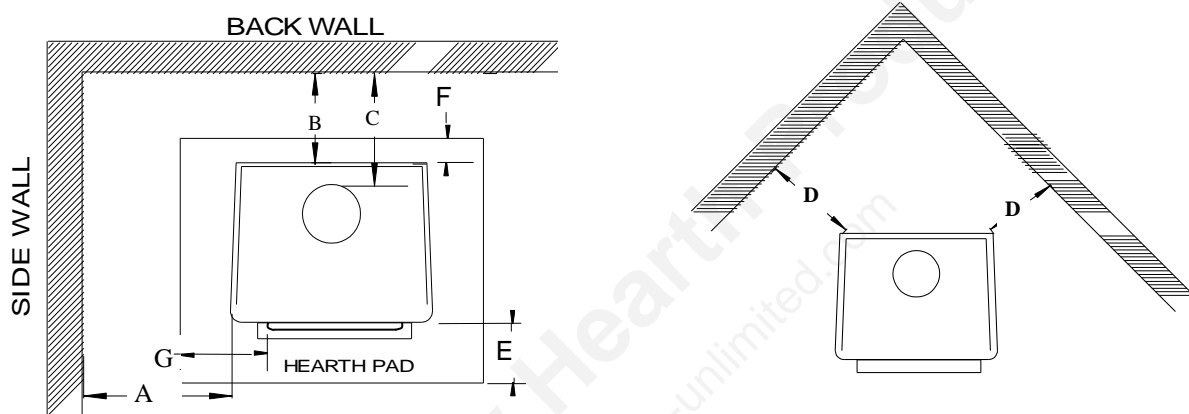

Figure 9

	A	B	C	D	E	F	G
MODEL 81	23"	23"	25"	16"	16"	8"	8"

**NOTE:** All clearances are to combustibles without low clearance shields and using single wall pipe and minimum floor protector. Clearances above may be reduced. Follow **NFPA-211** codes if available or follow instructions on next page.

\* Floor Protector at rear needed for thru-the-wall exit only.

# CLEARANCES FOR MODEL 81 MINIMUM CLEARANCES TO COMBUSTIBLES SINGLE WALL CHIMNEY CONNECTOR AND OPTIONAL SHIELDS, MOBILE HOME AND ALCOVE INSTALLATIONS

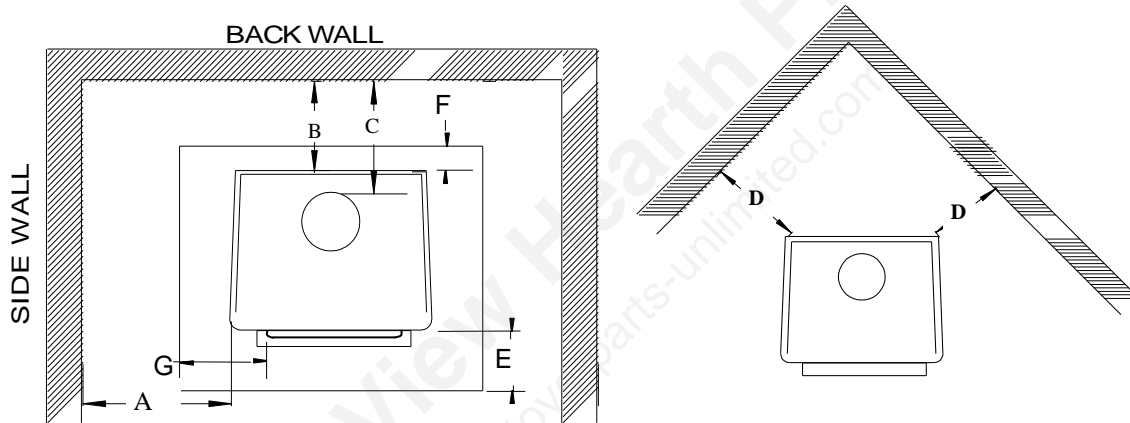

Figure 10

	A	B	C	D	E	F	G
MODEL 81	12"	16"	16.5"	12"	16"	8"	8"

**NOTE:** All clearances are to combustibles using single wall pipe and all low clearance shields and minimum floor protector.

\*Floor protector at rear needed for thru-the-wall exit only.

# INSTALLATION OF (OPTIONAL) CLOSE CLEARANCE SHIELDS

1. Center rear close clearance shield with back of stove. Mark back of stove, using reference holes in rear shield. Using self-tapping screws, drill four holes in locations marked. Remove screws and attach back shield to back of stove. (See figure 11a).
2. Insert front end of side shield behind side angle on front side of stove. Align top of side shield with top of back shield. Mark holes on back shield through holes in back of side shield. Using four self tapping screws, drill four holes in the locations marked. Tighten bottom screws and leave top screws loose for step 3. Use same step to install side shield on opposite side of stove. (See figure 11b).
3. Loosen two top screws holding side shield at back top. Insert pipe shield where back shield and top back side shield meets. Tighten screws. (See figure 11c).

REAR CLOSE CLEARANCE SHIELD

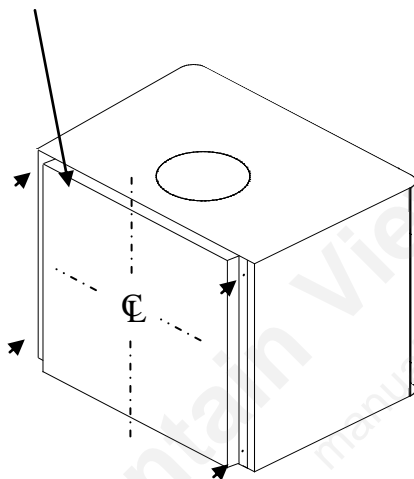

SIDE SHIELD'S

Keep rear / side shields even

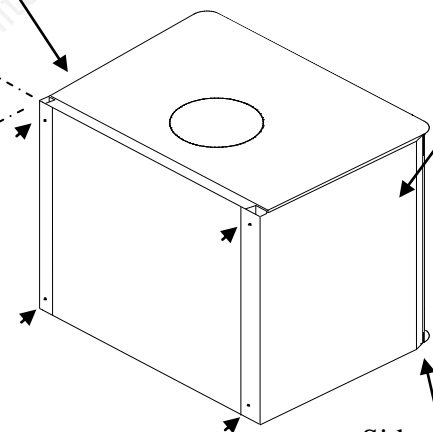

Side angle on front side of stove.

PIPE SHIELD

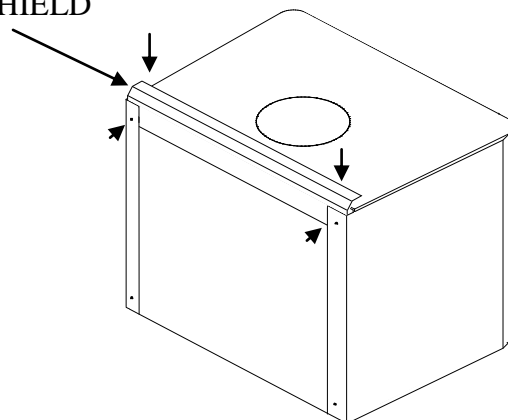

## SECTION V

# FREESTANDING MOBILE HOME INSTALLATION

FOR MINIMUM CLEARANCES SEE PAGE 21.

### Floor Protection:

When installing freestanding heater, a floor protector must be used. Floor protector must be 3/8" minimum thickness non-combustible material or equivalent.

### How to use alternate materials and how to calculate equivalent thickness

An easy means of determining if a proposed alternate floor protector meets requirements listed in the appliance manual is to follow this procedure:

1. Convert specification to R-value:
  - R-value is given—no conversion is needed.
  - K-factor is given with a required thickness (T) in inches:  
C-factor is given:  $R=1/C$
2. Determine the R-value of the proposed alternate floor protector.
  - Use the formula in step (1) to convert values not expressed as "R"
  - For multiple layers, add R-values of each layer to determine the overall R-value.
3. If the overall R-value of the system is greater than the R-value of the specified floor protector, the alternate is acceptable.

#### Example:

The specified floor protector should be 3/4" thick material with a K-factor of 0.84.  
The proposed alternate is 4" brick with a C-factor of 1.25 over 1/8" mineral board with a K-factor of 0.29.

Step (a): Use formula above to convert specification to R-value.  $R= 1/K \times T = 1/0.84 \times .75 = 0.893$

Step (b): Calculate R of proposed system. 4" brick of  $C=1.25$ , therefore  $R_{brick} = 1/C = 1/1.25 = 0.80$  1/8" mineral board of  $K = 0.29$ , therefore  $R_{min.bd.} = 1/0.29 \times 0.125 = 0.431$

Step (c): Compare proposed system R of 1.231 to specified R of 0.893. Since proposed system R is greater than required, the system is acceptable.

#### Definitions:

$$\text{Thermal conductance} = C = \frac{\text{Btu}}{(\text{hr})(\text{ft}^2)(\text{°F})} = \frac{\text{W}}{(\text{m}^2)(\text{°K})}$$

$$\text{Thermal conductance} = K = \frac{(\text{Btu})(\text{inch})}{(\text{hr})(\text{ft}^2)(\text{°F})} = \frac{\text{W}}{(\text{m})(\text{°K})} = \frac{(\text{Btu})}{(\text{hr})(\text{ft})(\text{°F})}$$

$$\text{Thermal conductance} = R = \frac{(\text{ft}^2)(\text{hr})(\text{°F})}{\text{Btu}} = \frac{(\text{m}^2)(\text{°K})}{\text{W}}$$

Install in accordance with 24 CFR, Part 3280 (HUD).

## TOOLS FOR INSTALLATION

Drop cloth, 3/32" Metal drill bit, 5/16" magnetic socket chuck adapter, 5/16" wrench (box or socket) or adjustable wrench, Jigsaw with masonry, metal and wood blades

**WARNING: DO NOT INSTALL IN A SLEEPING ROOM**

## PREPARING STOVE FOR INSTALLATION

1. Remove protective plastic wrapping from unit, inspect unit for any obvious physical damage.
2. Plug power cord into a 115V AC outlet to test motor and fan when optional motor is being used. "Do not run cord under unit or in high traffic areas".
3. Check primary air draft control to ensure that it slides freely. (See Figure 12).
4. Remove any items from within firebox. Spread a dropcloth on floor behind heater. Next, tilt heater so that back is on drop cloth.
5. **(Leg Kit):** If legs are to be used, obtain four legs, attach legs to holes in bottom of unit with bolts and washers supplied with leg kit. (See Figure 12).
6. **(Pedestal Kit):** If pedestal kit is being used an outside air is required, see *Out Side Air Installation* below. Before attaching heater to stand, take a large flat screwdriver or pliers and remove the 2" x 2" knockout on bottom of unit. (See Figure 12A). Open freestanding kit and obtain stand. Place stand against bottom of heater (angle side to heater). Center stand front to rear and also center stand left and right. Mark screw locations on bottom of stove through outer holes of stand mounting angles. Set stand aside and drill four 7/32" holes in heater bottom. Then mount stand to bottom of heater with screws provided. (See Figure 12A).
7. Obtain four (4) 3/16" self-tapping screws and secure stand to heater.
8. Reposition heater to upright position.

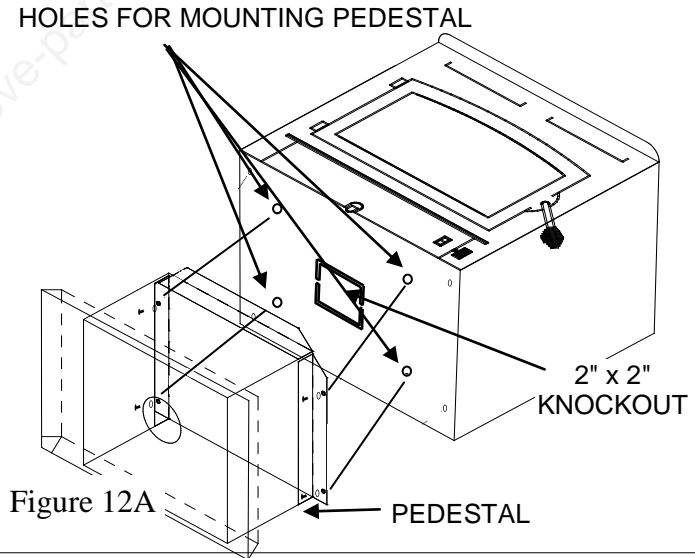
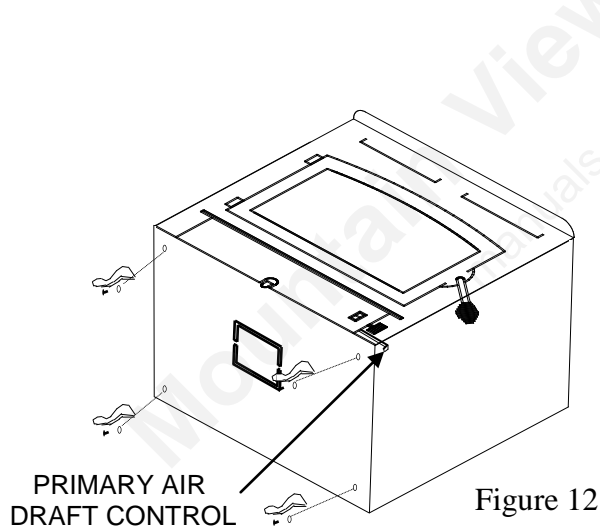

## Out Side Air Installation

### CAUTION

**THE STRUCTURAL INTEGRITY OF MOBILE HOME FLOOR MUST BE MAINTAINED. (MOVE OPENING AND/OR REPOSITION HEATER LOCATION IF NECESSARY).**

1. Select an installation location that will give best airflow from front of heater to remainder of home.
2. Place protective floorpad in position. For minim floor protection (See Page 24).

3. Place unit on pad making sure minimum clearance specifications are met. For minimum clearance to combustibles (See Page 22).
4. Lightly mark with a pencil location of pedestal on protective pad.
5. Next, remove four (4) screws holding heater to stand. Position heater out of way of installation area.
6. Check that pedestal stand is still aligned with marks on protective pad, now mark on pad the outside air opening in bottom of pedestal stand.
7. Mark center line of outside air opening. Set stand aside for now.
8. Cut a 4 1/4" diameter hole in pad and continue through floor.  
**CAUTION! The structural integrity of home floor must be maintained.**  
(Move opening and/or reposition heater location if necessary).
9. Now, reposition pedestal stand and set on pad being sure to line stand up with reference marks.
10. Using an electric drill and 3/8" masonry bit, drill four (4) holes in protective pad using holes in bottom of pedestal stand as a guide. Be careful to drill only through pad and not into floor. Change the bit to a 1/4" metal bit and drill through floor.
11. Using four (4) 3/8" x 1-1/2" lag bolts provided, secure pedestal stand and pad to floor of home.

## CAUTION

**IF A THICK FLOOR PROTECTOR IS USED, YOU MAY HAVE TO USE LONGER LAG BOLTS.**

12. Obtain outside air duct from box in pedestal kit marked FA P21B.
13. Slip duct down through 4-1/4" hole until face of outside air duct with screen wire, contacts bottom of pedestal.
14. Secure outside air duct to inside bottom of pedestal using four (4) #10x1 screws provided. (See Figure 13).
15. Set heater back onto stand and resecure using screws.
16. NOTE: If home is underpinned, you must duct through underpin as shown. (See Figure 13A).

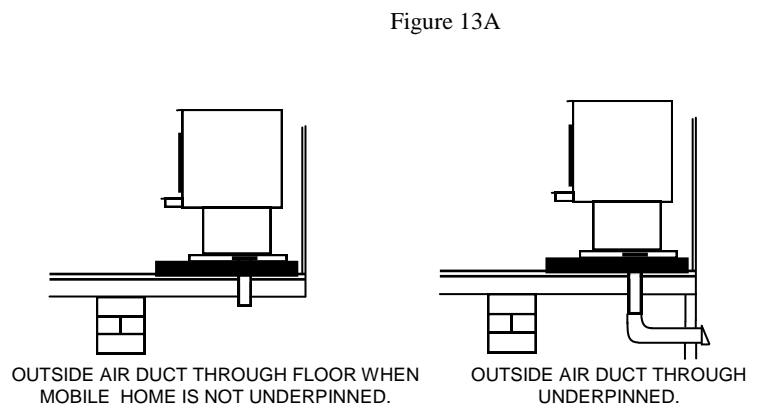
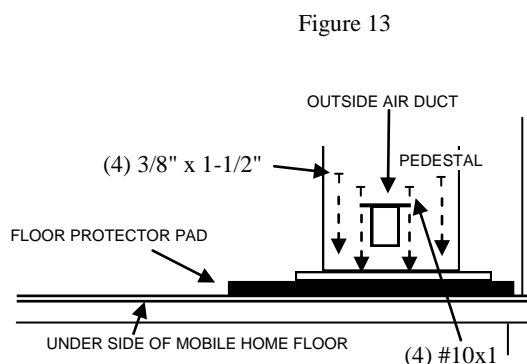

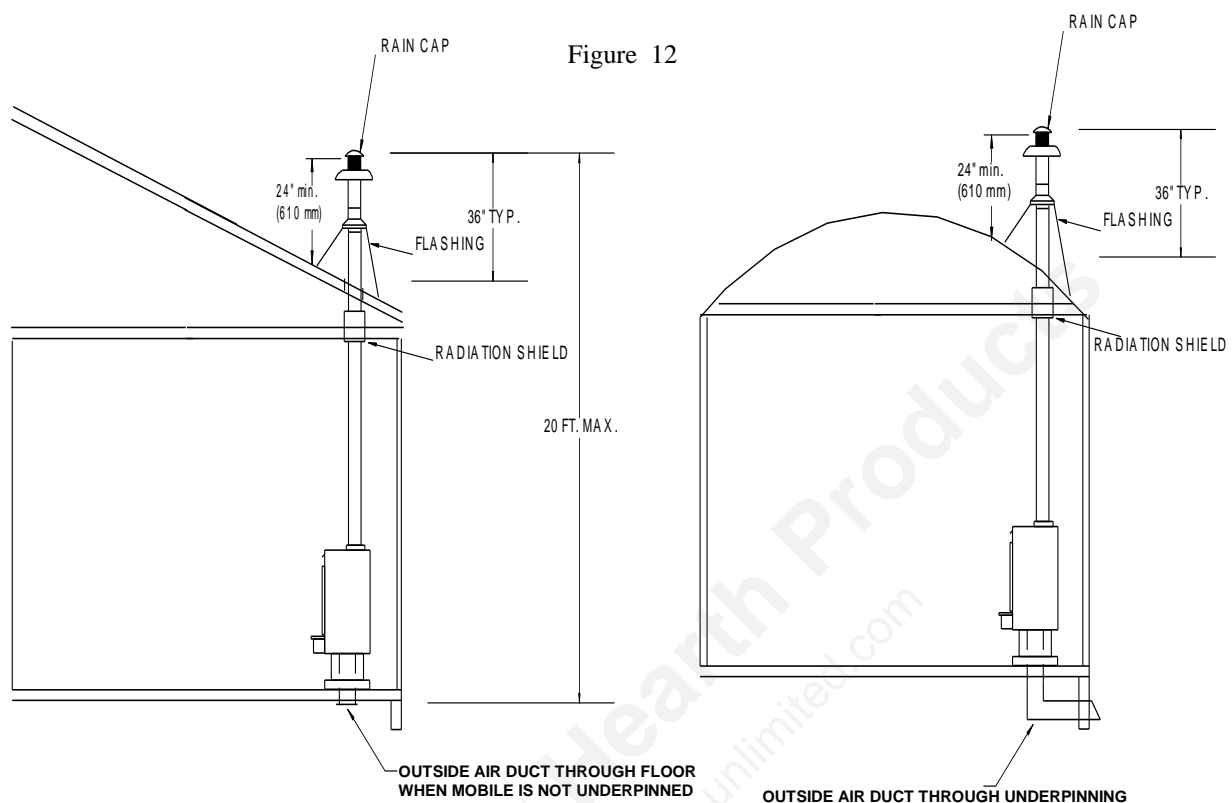

### Ceiling Exit (Using Close Clearance Listed Chimney)

1. Suspend a plumb bob from ceiling above unit so that weight is hanging in center of flue exit. (A small weight on a string will serve as a plumb bob). Mark ceiling where string is suspended to locate center of chimney hole.
2. After locating center of hole, install ceiling support box, chimney or chimney connector, flashing and rain cap using listed 2100° HT chimney only. Only use pipe listed in this manual.

## CAUTION

**REFER TO CHIMNEY MANUFACTURERS INSTRUCTIONS FOR ASSEMBLY AND DISASSEMBLY OF CHIMNEY PARTS. BE SURE TO FOLLOW CHIMNEY INSTRUCTIONS FOR PROPER CLEARANCES TO COMBUSTIBLE AND PROPER AIR SPACING REQUIRED.**

3. Add additional pipe until both of the following are met:

- (a) Chimney pipe is 3' higher than roof at point where it penetrates roof.
  - (b) Chimney pipe height is at least 2' higher than any part of roof within 10' of chimney.  
(See Page 27, Figure 12).
4. Next, install a New Buck Corporation chimney connector to flue of heater or use 3 “EII” brackets and secure to top of heater and pipe.
  5. Using single wall chimney connector, connect heater to chimney by following manufacturer’s installation instructions exactly. (See Figure 13).

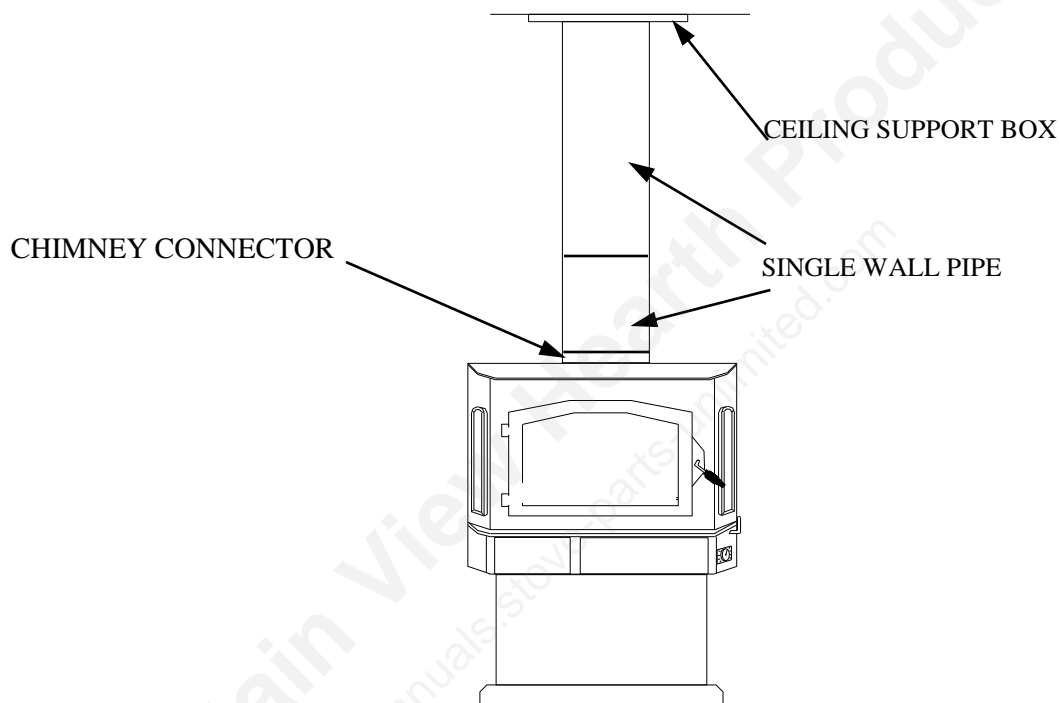

Figure 13

## FINAL CHECK

1. Recheck specified clearances.
2. Remove all foreign material from firebox area.
3. Open primary air draft.

**NOTE:** Plug power cord into a 115V AC outlet. Set switch to “Manual” and rheostat to “High” position to ensure motor operates properly. Route cord to prevent damage to cord insulation from heat and sharp objects. Keep cord out of way of traffic to prevent damage caused by tripping, etc.

4. Place crumpled pieces of newspaper in stove. Light it and close door. Ensure that stove draws properly through primary draft.
5. Check for smoke leaks around door.
6. Open door and check for smoke escaping from front of stove. Smoking usually indicates a defective or poorly positioned chimney. Some chimneys with a marginal draft can be preheated by lighting newspaper and holding it near open damper with a poker or fire tong. Once chimney heats up, a proper draft can usually be obtained.

If a thorough review of Troubleshooting Guide in manual does not reveal problem, contact your dealer for assistance.

## CAUTION

**THE UNIT IS PAINTED WITH A SPECIALLY FORMULATED HIGH TEMPERATURE PAINT THAT CURES DURING FIRST TWO OR THREE FIRINGS. YOU MAY NOTICE A SLIGHT SMOKING EFFECT AND AN ODOR OF BURNING PAINT WHEN YOU BUILD THE FIRST FIRES. THIS IS NORMAL AND IS NOT A CAUSE FOR ALARM. IN SOME CASES, THESE FUMES WILL ACTIVATE A SMOKE ALARM. OPENING A WINDOW NEAR THE UNIT WILL ALLOW THESE FUMES TO ESCAPE. DO NOT BUILD A LARGE ROARING FIRE UNTIL THIS CURING PROCESS IS COMPLETE OR HEATER FINISH MAY BE DAMAGED.**

## SECTION VI WOOD HEATER SAFETY

Certain safety hazards are inherent in any wood heater installation. You should be aware of these so that a safe and proper installation can be made.

1. **FAULTY CHIMNEY:** An older masonry chimney should be thoroughly checked to be sure there are no holes or weak spots which could allow sparks or hot gases to escape.
2. **HEAT CONDUCTION:** Placing combustible materials too close to a heater or chimney can be a fire hazard.

By keeping these particular hazards in mind as you install and use your room heater you can ensure a safe, reliable installation.

The chimney and chimney connector should be inspected once every two months. Any build-up of soot should be removed to prevent risk of a chimney fire. To remove chimney or chimney connector, remove screws or fasteners, remove pipe and clean with steel brush. Replace chimney or chimney connector and replace screws and/or fasteners.

## CAUTION

**NEVER USE GASOLINE, GASOLINE TYPE LANTERN FUEL, KEROSENE, CHARCOAL LIGHTER FLUID OR SIMILAR LIQUIDS TO START OR "FRESHEN UP" A FIRE IN THE HEATER. KEEP ALL SUCH LIQUIDS WELL AWAY FROM THE STOVE WHEN IT IS IN USE. ALL FLUIDS OF THIS TYPE GIVE OFF VOLATILE FUMES AND CAN AND WILL EXPLODE! DON'T TAKE A CHANCE WITH SAFETY OF YOUR HOME AND FAMILY.**



**CAUTION:** Never remove ashes from your heater with blower running.

**DISPOSAL OF ASHES:** Ashes should be placed in a metal container with a tight fitting lid. The closed container of ashes should be placed on a noncombustible floor or on the ground, well away from all combustible materials pending final disposal. If ashes are disposed of by burial in soil or otherwise locally dispersed, they should be retained in closed container until all cinders have thoroughly cooled.

**CREOSOTE-FORMATION AND NEED FOR REMOVAL:** When wood is burned slowly, it produces tar and other organic vapors, which combine with expelled moisture to form creosote. The creosote vapors condense in a relatively cool chimney flue of a slow-burning fire. As a result, creosote residue accumulates on flue lining. When ignited, this creosote makes an extremely hot fire.

## SECTION VII OPERATION

This section of manual is to help you get maximum efficiency and maximum smoke (particulate) reduction from your heater. If you should experience any difficulty or have any questions concerning your heater, contact your dealer for assistance.

Manufacturer recommendation for peak performance is to burn naturally seasoned hardwood (wood dried 6-12 month) and place wood from front to back position in the heater.

**NOTE:** Soft woods such as pine, create more creosote, clogging of chimney, and produce a less efficient burn performance.

**Build a fire for maximum efficiency.** These models burn wood and extract heat so efficiently, a large fire is not necessary. A large fire not only wastes energy, it usually results in home being too warm for comfort.

The following steps will serve as a guide for operating your stove.

## BUILDING A FIRE

1. Open door.
2. Open primary air control located on right side of stove under hearth. (See Page 25, Figure 14). To close, push all the way in. To open, pull all the way out. Adjustments to airflow may be made by positioning handle anywhere in between.
3. Twist two pieces of non-colored newspaper into a roll and place them on floor of firebox.
4. These models are not designed for use of grates, andirons or other methods of supporting fuel.

**NOTE: Do not use grate or elevate fire. Build wood fire directly on inner bottom of fire box.**

5. Lay several pieces of dry kindling on top of newspaper.
6. Place three or four small pieces of firewood, 2-3" in diameter, on top of kindling.
7. Light newspaper in front, close and latch door. Don't leave fire unattended at this point. The draft system of heater should start quickly. It may be necessary to preheat chimney to get a draft started. To do this, open door and add newspaper to top rear of wood. Light or let this paper ignite and allow to burn while holding door slightly cracked. Once draft has started, close and lock door. You are over heating unit if chimney and/or connector glows red.

NOTE: After embers and a coal bed have been established, load heater with dried, natural seasoned hard wood.

**NOTE: THE FUELING AND ASH REMOVAL DOORS MUST REMAIN CLOSED DURING OPERATION.**

BURN RATE:	LOW	MED-LOW	MED-HI	HI
AIR SETTINGS:	1/16"	1/8"	1/4"	WIDE OPEN
FAN SETTINGS:	LOW FOR 30min.	LOW FOR 30min.	LOW FOR 30min.	HIGH/ALL TEST

Manufacturer recommendation for peak performance is to burn natural seasoned hardwood (wood dried 6-12 months) and place wood from front to back position in heater.

**NOTE: If blower is being used on the Model 81, your stove is equipped with a automatic thermostat. When stove gets hot enough, thermostat will activate room air blower.**

**= Set fan speed on low, when burn on low, med-low, med-high.**

**= Set fan speed on high when burn on high.**

NOTE: When refueling or removing ashes turn "OFF" room air blower. Be sure to turn room air blower back on when finished.

NOTE: Do not run power cord underneath heater or in walk way or heavy traffic areas.

Your unit does not have a damper. You must use primary air lever for your control of fire. To open, pull lever out. To close, push lever in. (See Page 25, Figure 12).

# ROOM AIR BLOWER OPERATION

Your heater is equipped with a room air blower. For operation and wiring (See Figure 14).

For your convenience, your heater is equipped with a rheostat with which you are able to select the air flow. The auto and manual switch will allow you to select the position at which thermostat will function.

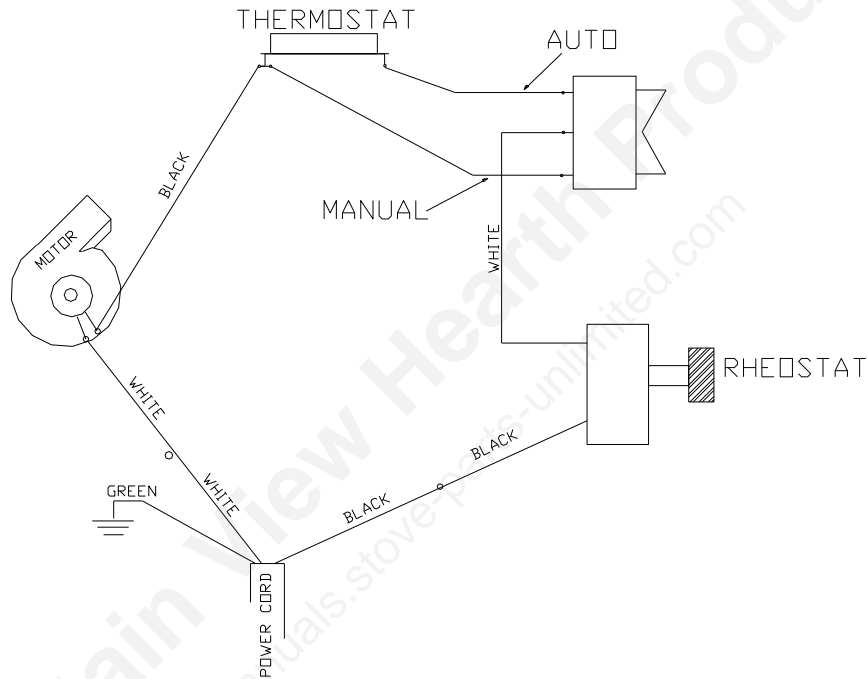

Figure 14

**Auto-position:** After heater has warmed up and Auto-Manual switch is placed in “Auto” position and rheostat is in desired position, fan will automatically come on. When stove cools off, fan will automatically shut-off.

**Manual position:** You must turn room air blower on and off.

**NOTE:** Plug power cord into a 115V AC outlet. Set switch to “Manual” and rheostat to “High” position to ensure motor operates properly. Route cord to prevent damage to cord insulation from heat and sharp objects. Keep cord out of way of traffic to prevent damage caused by tripping, etc.

**NOTE:** When refueling or removing ashes turn “OFF” room air blower. Be sure to turn room air blower back on when finished.

## SECTION VIII TROUBLESHOOTING

<b>PROBLEM</b>	<b>POSSIBLE CAUSE</b>	<b>SOLUTION</b>
1. Sluggish heater	1. Obstruction in chimney 2. Improperly sealed trim kit or direct connect kit 3. Wet or unseasoned wood being burned. 4. Poor chimney draft	1. Check for and remove obstruction 2. (a) Check trim kit gasketing seal to fireplace and gasket as necessary to seal unit. Gasket under front bottom of stove if needed. (b) Check seal if direct connect and correct 3. Burn dried natural seasoned hard wood 4. Improper chimney height or wrong size flue is being used. Cooler temperatures caused by external chimney
2. High Fuel Consumption	1. Improper regulation of draft or inlet air 2. Improper door fitting	1. Close inlet air control as much as possible to maintain desired heat output. Check gaskets, reinstall fiberglass gasket around doors and glass as necessary 2. Check door gasket, check adjustment of door latch, check door hinges
3. Back puffing	1. Gusts of Wind	1. Smoke shelf in chimney is filled with creosote & ash. Chimney may need wind diverter. Raise chimney for better draft
4. Smoke rollout when heater door is opened	1. Wind gusts blowing down the chimney 2. Opening heater door too fast	1. Smoke shelf in chimney is filled with creosote & ash. Chimney may need wind diverter. Raise chimney for better draft 2. Open air control. Crack door for 15 seconds before fully opening door

# REPLACEMENT PARTS FOR THE MODEL 81

1. Air Control Bar	MF 810084
2. Door Handle Assembly	PA 910096
3. Door Latch	PC 910098
4. Door Handle Washer	PO 91WASH
5. Front door bushing	PO 910102
6. Door Gold	PC 212400G
7. Door Black	PC 212400
8. Off/Auto/Man Fan Switch	PE RC211RB
9. Thermostat 110 disc	PE 400132
10. Power Cord	PE 400240
11. Strain Relief	PE 400320
12. Motor	PE 910714
13. Rheostat	PE BC204
14. Rheostat knob	PE BC204A
15. Glass	PG 2124GL
16. Glass, Bay side	PG 810100
17. Glass clip	PH 103212HWSPS5
18. Spring Handle	PO 100150
19. "U" Drive Screw 5/16" x 1/2"	PO 516U
20. Top Baffle Board	PO BPF81B
21. Secondary Air Tube	PO 810050
22. Primary Air Block	MF 810081
23. Side Brass Overlay	PO 810104G
24. Hearth Brass	PO 810705
25. 1" x 1" x 1/8" thick magnet	PO DM841
26. Firebrick	PR 900050

**NEW BUCK CORPORATION (NBC)**  
**"LIMITED WARRANTY" FOR THE BUCK STOVE**  
**PLEASE READ THIS WARRANTY CAREFULLY**

**PRODUCTS COVERED**

This warranty covers the new Buck Stove heating unit, so long as it is owned by the original purchaser, including optional and standard accessories purchased at the same time, subject to terms, limitations, and conditions herein set out.

**PRODUCTS NOT COVERED**

This warranty does not cover the following:  
Glass, Refractory Material, Firebrick or Gaskets.

This Warranty will not cover any damage and/or failure caused by abuse or improper installation of the products covered.

**WARRANTY TIME PERIODS**

**(A) Period I**

For one year from the date of purchase, NBC will replace or repair, at its option, any part defective in materials or workmanship. The costs of parts only are included. The customer pays any labor or transportation charges required.

Thereafter,

**(B) Period II**

For the period after the first year from the date of purchase and extending for five years as long as the Buck Stove is owned by the original purchaser, NBC will repair or replace, at its option, any part defective in materials or workmanship, with the exception of, electrical motors, wiring, switches, components, optional and standard accessories, and all parts not permanently attached to the heating unit. Parts not permanently attached to the heating unit are defined as those items designed to be removed from the stove, including those removable with common hand tools. The costs of parts only are included. The customer pays any labor or transportation charges required.

**PROCEDURE**

Should you feel that your BUCK STOVE is defective, you should contact any Buck Stove dealer for the name of your nearest authorized Buck Stove service representative, who will instruct you on the proper procedure, depending on which Warranty Time Period (Period I or Period II) applies.

If for any reason you are dissatisfied with the suggested procedures, you may contact us in writing at:

New Buck Corporation  
Customer Service Department  
P. O. Box 69  
Spruce Pine, NC 28777  
Email: info@buckstove.com

## CONDITIONS AND EXCLUSIONS

- (A) Replacement of parts may be in the form of new or fully reconditioned parts, at NBC's option.
- (B) There is no other express warranty. All implied warranties of merchantability and fitness for use are limited to the duration of the Express Warranty.
- (C) New Buck Corporation is not liable for indirect, incidental, or consequential damages in connection with the use of the product including any cost or expense of providing substitute equipment or service during periods of malfunction or non-use. Some states do not allow the exclusion of incidental or consequential damages, so the above exclusion may not apply to you.
- (D) All warranty repairs under this warranty must be performed by an authorized Buck Stove service representative. Repairs or attempted repairs by anyone other than an authorized service representative are not covered under this warranty. In addition, these unauthorized repairs may result in additional malfunctions, the correction of which is not covered by warranty.

## OTHER RIGHTS

This warranty gives you specific legal rights, and you may also have other rights, which vary from state to state.

## OWNER REGISTRATION CARD

The attached Owner Registration Card must be completed in its entirety and mailed within 30 days from the date of purchase or from the date of installation, if installed by a factory certified installer, to New Buck Corporation in order for warranty coverage to begin.

**PLEASE NOTE:** The Owner Registration Card must contain the Authorized Buck Stove Dealer Code Number and the Certified Installer's number (if applicable) for warranty coverage to begin.

To be completed by selling distributor/ dealer/ customer:

Name \_\_\_\_\_  
(Last) (First)

Address \_\_\_\_\_

City \_\_\_\_\_ State \_\_\_\_\_ Zip \_\_\_\_\_

*CUSTOMER EMAIL:* \_\_\_\_\_

**MODEL 81** - Serial Number \_\_\_\_\_

Date of Installation: Day \_\_\_\_\_ Month \_\_\_\_\_ Year \_\_\_\_\_

Installer's Name \_\_\_\_\_

Installer's Certification Number \_\_\_\_\_

Dealer's Name \_\_\_\_\_

City \_\_\_\_\_ State \_\_\_\_\_ Zip \_\_\_\_\_