



# Country Flame Catalytic

INSTALLATION OPERATION  
& MAINTENANCE MANUAL

FOR

O2 INSERT MODEL

RETAIN THESE INSTRUCTIONS

## SAFETY NOTES

**WARNING: COUNTRY FLAME RECOMMENDS A CERTIFIED PROFESSIONAL INSTALL AND SERVICE WOOD BURNING STOVES. IMPROPER INSTALLATION OR SERVICE WILL VOID THE COUNTRY FLAME WARRANTY. IMPROPER INSTALLATION CAN ALSO RESTRICT, LIMIT, OR VOID A HOMEOWNER'S INSURANCE POLICY. READ THIS ENTIRE MANUAL BEFORE UNDERTAKING THE INSTALLATION PROCESS. IMPROPER INSTALLATION IS THE LEADING CAUSE OF WOOD STOVE PROPERTY DAMAGE. A HOUSE FIRE, BODILY INJURY OR EVEN DEATH CAN OCCUR DUE TO IMPROPER STOVE INSTALLATION. CHECK WITH LOCAL BUILDING OR FIRE INSPECTORS ABOUT LOCAL CODE RESTRICTIONS AFFECTING INSTALLATION.**

1. Country Flame Technologies grants no warranty, implied or written, for the installation or maintenance of any catalytic stove. As such, Country Flame assumes no responsibility for any consequential damage resulting from the improper installation or improper care of any specific catalytic stove.
2. Please fill out and return the warranty card within 30 days of purchase of a specific model catalytic stove.
3. **ALWAYS** consult local building authorities to determine if a permit is required for installation of any stove covered by this manual.
4. **ALWAYS** consult local codes before installation to obtain information on local restrictions or additional local code requirements.
5. **ALWAYS** maintain minimum clearances from all combustible surfaces and materials including clothing, drapes, furniture, carpets, walls, wood, paper, etc. Do not store firewood within clearances established for a catalytic stove.
6. This stove requires a non-combustible fireplace hearth. Refer to the floor protection section in this manual.
7. **ALWAYS** connect any stove covered in this manual to a (a) listed UL103 or USC S629 rated type HT (2100°F) chimney or (b) code-approved masonry chimney with an appropriate flue liner. The chimney size should not be less than the stove flue collar size or more than three times greater than the cross-sectional area of the flue collar.
8. **NEVER OVER FIRE ANY FIREPLACE.** If any part of a catalytic stove or chimney glows red it has been over fired. Over firing causes a catalytic stove to operate at temperatures outside its designed capability. Over firing immediately voids the catalytic stove warranty.
9. **NEVER** attempt to repair any part of a catalytic stove. Only qualified service personnel should make installations and repairs. Any parts removed for servicing must be replaced prior to operation.
10. **NEVER** leave a catalytic stove unattended and burning on high. Uncontrolled and unattended high burn fires will lead to over firing.
11. **NEVER** connect a stove described in this manual to a chimney flue already connected to another appliance.
12. **NEVER** install any Country Flame catalytic stove in a sleeping room.
13. **NEVER CONNECT ANY PART TO AN EXISTING HOME AIR DUCT DISTRIBUTION SYSTEM.**
14. **NEVER** use gasoline, lantern fuel, kerosene, charcoal lighter fluid, or similar combustible liquids to start or freshen up a fire. Vapors from these liquids are highly explosive. Keep them a safe distance from stove.
15. **ALWAYS** use only solid wood fuel. Country Flame catalytic stoves have been approved for burning only dry seasoned natural wood.
16. **NEVER BURN GARBAGE, FLAMMABLE FLUIDS, OR TREATED WOOD.**
17. **NEVER** allow creosote to build up in the chimney system. Inspect the chimney system at least twice monthly during use and clean as required. Using green or improperly seasoned wood can greatly increase the production of creosote. Use wood with less than 25% moisture content in order to minimize creosote buildup.
18. **ALWAYS** wait until the unit is completely cool to perform any maintenance or cleaning procedures.
19. **THIS STOVE IS HOT WHILE IN OPERATION. KEEP CHILDREN, CLOTHING, AND FURNITURE AWAY. CONTACT MAY CAUSE SKIN BURNS.**
20. **SUPERVISE** children when they are in the same room with an operating fireplace.
21. **ALWAYS** follow the lighting instructions in this manual; short cuts of any kind can be dangerous.
22. **ALWAYS** check local building codes and consult with your insurance company before installing your unit.
23. **ALWAYS** dispose of ash accumulations from your unit, using a metal container with a tight fitting lid. Place the closed ash container on a non-combustible surface well away from all combustible materials, pending final disposal. Retain all ashes in the closed container until they have thoroughly cooled.
24. **INSTALL** any safety screen; guard, or doors removed for maintenance prior to operation.
25. **NEVER** block free airflow through open vents connected to the fireplace units.
26. **INSTALL** a smoke detector within the proximity of a catalytic stove.
27. **ALWAYS** observe the unit closely during operation. If any part of the catalytic stove starts to glow red or white, it is in an over fire condition. Close the air controls completely until the glowing material has returned to a normal dark color.

28. **NEVER** burn wet or green wood. Firewood should be stored in a dry location away from the elements.
29. Check your chimney system carefully before installation. If in doubt about a chimney's condition, contact a certified professional.
30. **ALWAYS** comply with all minimum clearances to combustibles as they appear in this manual.
31. See the listing label located on the back of the catalytic stove for additional safety information.
32. **ALWAYS** start a fire with paper and kindling. Adding of wood fuel should be moderate as the fire progresses. Do not burn large quantities of paper or foreign materials that create an extremely hot, quick fire that can lead to over fire conditions.
33. **NEVER** burn a catalytic stove with the damper open, except when reloading a stove.
34. **ALWAYS** build fires directly on the refractory brick floor. DO NOT use andirons or grates or elevate the fire in any other manner.
35. For further information on using your catalytic wood stove, obtain a copy of the National Fire Protection Association's "Using Coal and Wood Stoves Safely", NFPA No. NS-10-1978. The address of the NFPA is 470 Atlantic Avenue, Boston, Massachusetts 02210.
36. **INSTALLATION** of a catalytic stove shall be in accordance with the Manufactured Home and Safety Standard (HUD), CFR 3280, Part 24.
37. Never allow the combustion or blower air intake to be blocked. Once a stove is installed as an insert do not allow a raised hearth to create a blockage.
38. **CAUTION:** Do not turn a room air blower on until the fire has been burning for 30 minutes or longer. (This is not applicable to units without the blower option.)
39. Never slam the door, strike the glass, or over tighten the glass screws.
40. **ALWAYS** operate a Country Flame catalytic stove with the door closed, except during refueling operation.
41. Do not burn coal in your stove
42. Keep the door of the unit closed except during the fueling process.
43. Check the door and glass seal frequently and keep them in good condition.
44. **SAVE THESE INSTRUCTIONS**

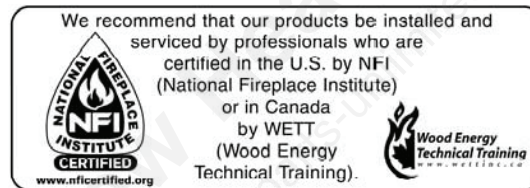

CONTACT YOUR LOCAL BUILDING OR FIRE OFFICIALS ABOUT RESTRICTIONS AND INSTALLATION INSPECTION IN YOUR AREA

LISTED SOLID FUEL BURNING SPACE HEATER/FIREPLACE INSERT



W/N 01782

Manufactured by: American Energy Systems, Inc. 150 Michigan Street SE Hutchinson, MN 55350

"PREVENT HOUSE FIRES"

Install and use only in accordance with manufacturer's installation and operating instructions and your local building codes.

CAUTION: Do not connect this unit to a chimney flue serving another appliance. Do not pass chimney connector through a combustible wall or ceiling. See local building code and manufacturer's instructions for precautions required when passing chimney through a combustible wall or ceiling.

Do not use grate or elevate fire—Build wood fire directly on fire brick.

WH-

Model: 02-I
Tested To: UL 1482
Test Date: January, 1991
Report No. 632-100200
Type Of Fuel: Solid Wood Only

Electrical Rating: 115 VAC 1.15 Amps 60 Hz

DANGER: Risk of electrical shock. Disconnect power before servicing unit. Do not route power cord beneath heater. Operate with doors closed.

Install insert with a minimum of 16" clearance to combustible sidewall, 2" to side and 12" to top trim, 24" from top of insert to mantel. Use a Listed floor protector or any equivalent non-combustible material. A Listed floor protector with minimum "R" value of 1.0 must extend a minimum of 8 inches to each side of unit and 18 inches to the front of unit. Install and use only in a masonry fireplace. Do not remove bricks or mortar from masonry fireplace to accommodate insert.

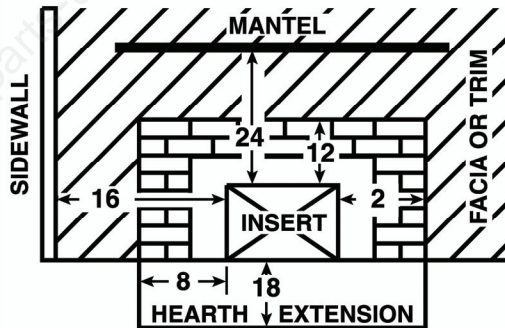

CHIMNEY & CONNECTOR: Use 6" diameter Class "A" chimney and minimum 24 MSG black or blue steel chimney connector. Horizontal connector permitted for all models. Connect to a code-approved masonry chimney or listed factory-built fireplace chimney with a direct flue connector into the first chimney liner section.

U.S. ENVIRONMENTAL PROTECTION AGENCY Certified to comply with July 1990 particulate emission standards.

This wood heater contains a catalytic combustor, which needs periodic inspection and replacement for proper operation. Consult owner's manual for further information. It is against the law to operate this wood heater in a manner inconsistent with operating instructions in the owner's manual, or if the catalytic element is deactivated or removed.

Date of Manufacture

2009 2010 2011 Jan. Feb. Mar. Apr. May June July Aug. Sept. Oct. Nov. Dec. [checkboxes]

DO NOT REMOVE THIS LABEL Made in U.S.A. IGN

# TABLE OF CONTENTS

<b>SAFETY NOTES</b> .....	<b>2-3</b>
<b>O2 SAFETY LABEL (INSERT APPROVED ONLY)</b> .....	<b>4</b>
<b>TABLE OF CONTENTS</b> .....	<b>5-6</b>
EPA CERTIFIED.....	7
LISTING/TESTING AGENCY.....	7
MANUAL USAGE.....	7
<b>FORWARD – WHY A CATALYTIC STOVE?</b> .....	<b>8</b>
EARLY HISTORY.....	8
HISTORICAL RESULTS .....	8
Refer a friend.....	9
<b>THEORY OF OPERATION</b> .....	<b>10</b>
<b>LIMITED LIFETIME WARRANTY</b> .....	<b>11-13</b>
<b>INSERT INSTALLATION PROCEDURES</b> .....	<b>14</b>
FACTORY BUILT FIREPLACES.....	14
MASONRY BUILT FIREPLACES .....	14
DRAFT .....	15
MINIMUM CLEARANCES .....	15
SHROUD AND TRIM INSTALLATION.....	15-16
<b>MOBILE HOME INSTALLATION NOT CERTIFIED</b> .....	<b>16</b>
<b>STOVE TERMINOLOGY</b> .....	<b>17</b>
STOVE COMPONENTS.....	17
MANUAL DRAFT CONTROLS.....	17
CATALYTIC BYPASS ROD.....	18
BLOWER UNITS.....	18
FIREBRICK REPLACEMENT.....	18
CATALYTIC COMBUSTORS.....	18-19
8” PROBE THERMOMETER.....	19
WOOD FUEL REQUIREMENTS .....	36
CHIMNEY.....	19
CHIMNEY CONNECTOR .....	20
FLUE TRANSITION .....	20
WALL THIMBLE .....	20
<b>MODEL O2 (INSERT ONLY)</b> .....	<b>21-22</b>
<b>MODEL O2 SPECIFICATIONS (INSERT ONLY)</b> .....	<b>23</b>
<b>APPENDIX A: REPLACEMENT PARTS DESCRIPTION</b> .....	<b>24-26</b>
CATALYST PARTS .....	24
DOORS.....	24
ELECTRICAL.....	24
REFRACTORY BRICK.....	24
GLASS.....	24
HANDLES & KNOBS .....	25
HARDWARE .....	25
INSULATION .....	25
MISCELLANEOUS.....	25
MOTORS.....	25

OWNER'S MANUAL .....	25
TRIM & GRILLS.....	25-26
GASKETS .....	24
<b>APPENDIX B: OPERATION &amp; MAINTENANCE.....</b>	<b>27</b>
FIRST FIRE, STEP 1.....	27
FIRST FIRE, STEP 2.....	27
FIRST FIRE, STEP 3.....	27
FIRST FIRE, STEP 4.....	27
FIRST FIRE, IGNITION .....	27-28
DRAFT PROBLEMS .....	28
FIRST LARGE FIRE.....	29-30
CARE OF STOVE GLASS: .....	30
GLASS REPLACEMENT.....	30
GLASS-CERAMIC SPECIFICATIONS.....	31
GLASS-CERAMIC CLEANING.....	31
DECORATIVE DOORS .....	32
ROOM AIR BLOWER MAINTENANCE.....	32
ROOM AIR BLOWER TESTING .....	33
BLOWER MALFUNCTION.....	33
NO ELECTRICITY.....	33
CREOSOTE BUILDUP.....	33
FIREBOX TIPS AND TECHNIQUES.....	34
<b>APPENDIX C: CATALYTIC SYSTEM .....</b>	<b>35-36</b>
THE CATALYTIC COMBUSTOR .....	35
CATALYTIC COMBUSTOR CLEANING.....	35
REPLACING THE COMBUSTOR.....	36
WARRANTY .....	37
HOME INSURANCE.....	37
FEDERAL LAW .....	37
COMBUSTOR PROBLEMS .....	37
CLEANING INSPECTION.....	37
REPLACEMENT INSPECTION.....	37
REPLACEMENT .....	37
MODEL O2 CATALYST INSPECTION & REPLACEMENT.....	38
CLEANING INSPECTION.....	38
REPLACEMENT INSPECTION.....	38
REPLACEMENT .....	38
<b>APPENDIX D: BLOWER SYSTEMS, ELECTRICAL .....</b>	<b>39</b>
BLOWER THEORY OF OPERATION .....	39
MODEL O2 .....	39
<b>APPENDIX E: WARNING LABELS.....</b>	<b>40-42</b>
<b>APPENDIX F: TROUBLESHOOTING GUIDE.....</b>	<b>43-44</b>
<b>APPENDIX G: CHIMNEY &amp; VENTING GUIDE .....</b>	<b>45</b>
VENTING SYSTEMS.....	45
THIMBLE INSTALLATION.....	46
OUTSIDE AIR COMBUSTION .....	47-48
CHIMNEY INSTALLATION.....	48-51
PREFABRICATED CHIMNEY SYSTEM INSTALLATION .....	51-54

**READ, UNDERSTAND, AND CONFORM TO ALL INSTRUCTIONS PRIOR TO  
INSTALLATION AND OPERATION OF CATALYTIC STOVES COVERED IN THIS  
MANUAL!**

**KEEP THIS MANUAL IN A SAFE PLACE FOR FUTURE REFERENCE**

**EPA CERTIFIED**

All Country Flame catalytic stoves have passed rigorous emission standard testing. All Country Flame catalytic stoves have been certified by the United States Environmental Protection Agency.

**LISTING/TESTING AGENCY**

All Country Flame catalytic stoves have been tested to UL listing standards UL1482, ULC-S627 for installation into residential dwellings, including standard construction units or modular home units. All catalytic stoves tested to UL standards by Intertek Testing Services, NA, Inc., 8431



**MANUAL USAGE**

Please read, understand, and carefully follow all instructions, installation procedures, and proper care and maintenance advice found in this manual. Please observe the safety instruction contained in this manual. If there are any questions, please contact Country Flame or one of its authorized dealers.

## **FORWARD – WHY A CATALYTIC STOVE?**

Why consider a Country Flame Technologies catalytic stove for your home?

### **EARLY HISTORY**

During the 1970's Americans became obsessed with both indoor and outdoor air quality. By the early 1980's America's obsession turned into governmental regulatory controls as the screams for improved air quality reached fever pitch. Someone coined the phrase "fugitive emissions" and government agencies sprang into action to define, document, and control fugitive emissions being released into the atmosphere from just about any source imaginable.

Of course, government involvement meant that dozens of laboratories sprang into action to begin the study of fugitive emissions. Soon government laboratories had full-fledged programs studying the wood burning fireplace and stove industry. The objective: to define the atmospheric (fugitive) emissions that was resulting from the use of every fireplace or stove. At this historic point in time, the fireplace manufacturing industry changed from "art form to science" and spelled the doom of literally thousands of small "mom and pop" manufacturers.

The fireplace industry had long understood the correlation between the three parts of a fire: a) fuel, b) oxygen, and c) heat but the exacting theory of mixing these basic items and the resultants (emissions) eluded even the most sophisticated pre-1970 fireplace manufacturer. Not the government laboratories! Quantification (defining numbers) was a government specialty and thousands of papers were written on non-airtight and airtight fireplace combustion. These learned papers defined and quantified every aspect of wood burning particulate emissions.

### **HISTORICAL RESULTS**

The laboratory findings were conclusive. In 1970, wood stoves did emit large amounts of what has come to be known as polycyclic organic matter, or POM's. Many of these POM emissions were known to be carcinogens (meaning cancer causing.) Armed with new documented science and an overabundance of evidence caused the Regulator Agencies to spring into action. Soon draft government (federal and state) regulations were proposed that would establish limits on the emissions of just about every fuel-burning device, including wood burning products. Once these government regulations were rumored to be just a vote away, fireplace manufacturers sprang into action to design product that would meet the new evolving emissions criteria.

Country Flame Technologies was part of that late 1970's push to produce cleaner burning fireplace and stoves. Like all fireplace manufacturers, Country Flame asked the question, **HOW CAN EMISSIONS BE CONTROLLED?** The answer was as simple as the question, **ENSURE FIREPLACES BURN 100% EFFICIENT. 100% BURN EFFICIENCY ENSURES ALL UNACCEPTABLE EMISSIONS ARE ELIMINATED.** It is always easier to state the problem and an answer than it is to put it into practice. Country Flame engineers remained undaunted. In the early 1980's Country Flame Technologies began work on a full line of catalytic wood burning insert stoves. Country Flame's catalytic stoves have evolved into an efficient and clean wood-burning product line.

Most likely, if you have read this far, you are strongly thinking about or have purchased a Country Flame catalytic stove. After almost three decades of continuously developing this line of products, all of us at Country Flame are very proud of this American born, American tested, and American produced product. With a sense of pride and dedication, our employees wish you and your family a lifetime of happiness and warmth with a Country Flame catalytic stove. On behalf of Country Flame, **THANK YOU.**



American Energy Systems, Inc.  
150 Michigan St SE  
Hutchinson, MN 55350  
1-800-495-3195 320-587-8872 (fax)



## REFER a FRIEND, NEIGHBOR or FAMILY MEMBER . . .

**American Energy Systems believes that our success is fueled by your satisfaction of owning a quality Magnum or Country Flame product. Over the past 37 years, we have been very fortunate to have satisfied, loyal homeowners that have helped to grow our business. We've created the Magnum Referral Program as an added incentive to continue this trend.**

**Participating is easy** – just refer a friend, neighbor or family member and once they purchase a Magnum or Country Flame quality product to keep their family warm, **we'll send you a check for \$50.00 to show our appreciation!**

**Now that's an easy way to a FREE renewable energy home heating Magnum product!**

To refer a homeowner, provide the information on our quick referral program on-line at:

<http://www.americanenergysystems.com/customer-referral.cfm>

or call us at **1-800-495-3196**

or write us at **American Energy Systems, Inc.  
150 Michigan St SE  
Hutchinson, MN 55350**

Please provide Homeowner's: *Name, Address, City, State, Zip Code,  
Telephone and/or Email Address*  
and we'll take it from there.

**We appreciate your participation!**

**Program Conditions:**

A valid referral must be a homeowner that American Energy Systems has not had contact regarding our products. There is no limit to the number of Magnum or Country Flame referral payments that can be earned. A referral payment may be split when multiple parties refer the homeowner. There is no limit between the time of the referral and the time the purchase is made. American Energy Systems reserves the right to amend or cancel the referral program at any time.

## THEORY OF OPERATION

The purchase of a Country Flame Technologies catalytic stove is usually made based on its looks, its heating capacity, and because of reduced emissions (clean and efficient burn.) Once the catalytic unit has been properly installed in a home, usually the next question asked by the homeowner is how can a catalytic stove's favorable operational characteristics be maintained over the life of the product?

In 2004, the study of woodstove emissions and woodstove efficiency remains a strongly debated issue. "Experts" use significantly different methodologies to arrive at often-conflicting conclusions. One thing is for certain, these same experts unanimously agree on one aspect of a stove's pollution and creosote production process: All stove studies conclude that a homeowner's operating procedure dramatically impacts the production of POM's (fugitive emission) more than any other single factor that has been examined over the past 20 years! **BOTTOM LINE:** a homeowner must understand and operate a catalytic stove correctly to maintain its cleanliness and efficiency!

Catalytic stove theory is quite simple. The catalytic combustor begins oxidizing carbon monoxide and other flue gases around 600 °F. With the bypass flue open, the stove operates as a non-catalytic stove and fugitive emissions escape up the chimney unrestricted. As the stove reaches 700 °F degrees, close the bypass flue. All emissions are then forced to travel through the combustor on their way to the chimney. As the stove's temperature continues to rise, the combustor ignites more particulates effectively burning these emissions. This secondary combustion, as it is called, occurs traditionally at temperatures 300 °F to 600 °F degrees lower than in non-catalytic stoves. Once "light-off" of the catalytic combustor occurs, the overall efficiency and cleanliness of burn is dramatically improved in a catalytic stove.

The catalytic combustor creates a secondary burn process that "scrubs" the exhaust emissions producing a cleaner exhaust gas. When operated properly, the Country Flame catalytic stove benefits are a) improved efficiency, b) longer burn times, c) reduced chimney fire potential, and d) reduced operating costs. In order to maintain the Country Flame warranty, the catalytic combustor must be properly engaged at all times during operation. Removing the combustor is dangerous and can lead to uncontrolled or over firing. Operation of the stove with the combustor removed instantly voids Country Flame's warranty. Further, operating a woodstove in any manner that is restricted by Country Flame can cause a homeowner's insurance policy to be negatively affected. **REMEMBER:** Federal Law requires all catalytic woodstoves to be maintained and operated with combustors in place over the life of the stove.

The catalytic combustor is a honeycomb ceramic and noble metal device. The catalytic combustor initiates combustion of secondary gases at lower temperatures than would be possible without the combustor installed while not destroying itself. Most modern catalytic combustors are designed to survive over 12,000 hours of continuous use. Operator use, firing practices, and the type of fuel used can all negatively affect the life expectancy of the combustor. Signs of combustor problems include increased smoke from the chimney, creosote accumulation, poor performance of the unit, continued firebox smoking, and an increase in fuel consumption. Here are five ways to produce cleaner air when operating a catalytic woodstove:

1. Use the largest diameter log that is practical in a particular model.
2. Build as small a fire as practical.
3. Keep the firebox hot and attempt to maintain a constant stove temperature.
4. Do not dramatically change draft settings. Gradual draft changes improve performance.
5. Avoid excessively dry or wet fuel. 20 to 25% moisture content in wood is good.

**NEVER FORGET:** Correct operation of a catalytic woodstove is key to its efficiency and life expectancy!

# AMERICAN ENERGY SYSTEMS INC. LIMITED PRODUCT WARRANTY

**This warranty is in effect on all products sold after 01/01/2009 and supersedes any and all warranties currently in existence.**  
**Please keep a copy of this warranty for your personal records or in the event of a claim**

American Energy Systems Inc., hereinafter referred to as (AES), warrants to you, the original consumer purchaser, that this product is free from defects in material and workmanship for a period of five (5) years from the original purchase date minus any time past one (1) year from manufacturing date, and that the product's electrical parts and steel firepot, are free from defects in material and workmanship for a period of one (1) year from the original consumer purchase date minus any time past one (1) year from manufacturing date, and that the cast iron firepot models carry a lifetime warranty against defect in material or workmanship (excluding war page or deterioration), and that door glass carries a lifetime replacement warranty against heat breakage (does not cover accidental breakage) . There is expressly no warranty on installation of product, any venting, grates, gaskets, door latches, insulation, ceramic or brick boards/logs/backing, paint, plated surfaces/doors/trims, baffles, bushings, bearings, auger flightings, war page or discoloration of steel or plated parts or any other normal wearing part. In the event the product fails to conform to this warranty, AES, through the place where you purchased the product or if purchased on the AES E-Com store directly through AES, will provide the parts and components necessary to remedy such nonconformity. **AES will not be responsible for any labor, mileage or freight cost to the factory under this warranty.** This warranty is not transferable.

In order to obtain performance under this warranty, you must (1) have registered this warranty within 30 days of purchase by completing and returning the warranty registration card or filling in the on-line warranty registration form at [www.magnumheat.com](http://www.magnumheat.com), and (2) promptly report the claimed nonconformity to your place of purchase, also providing your name, address, phone number, proof of purchase, date of purchase, the model and serial number of the stove, digital pictures of installation and venting inside and outside of the home, pictures of the claimed nonconformity part and the claimed nonconformity. **All claims must be submitted in writing to your place of purchase.**

AES shall have no warranty obligations if this product; (1) was not purchased from an authorized AES dealer; (2) was not installed by a AES dealer or other qualified installer; does not have outside combustion air hooked directly to the unit; (3) was not operated and maintained in strict accordance with the manufacturer's instructions, local or national codes or (4) was subject to abuse, misuse, negligence or accident. AES shall have no warranty obligation for damage caused by improper handling, freight damage (must be reported to freight provider), over-firing, unapproved fuel, variance in feed rates, variances in BTU output or the unauthorized disassembly or modification of the product. AES shall have no warranty obligation if this warranty is not timely registered, for claims which are not submitted through the selling AES dealer, or for claims submitted verbally or without the required information and documentation.

Before exercising this warranty, an AES representative (the place where the product was purchased or AES approved person) must inspect the part/unit to determine if the part/unit is defective. If a local AES representative is not available the original purchaser of the product must submit digital pictures of the part/unit, installation of the unit to AES at [technical@magnumheat.com](mailto:technical@magnumheat.com) If the inspection reveals that the failure is due to defective material or workmanship and the part is covered by the conditions of this warranty, AES will, at its option, repair the defective part/unit. The sole duty of AES and liability under this warranty is limited to the repair of the covered defective part/unit. The purchaser shall assume all costs related to shipping the replacement parts or return of the unit to the factory for repairs. If it is determined that the defect was caused by AES, AES will cover the costs of shipping the repaired part/unit to an AES approved shipping point. AES will not cover additional freight or delivery services such as residence delivery charges, special handling, etc.

**INSTALLATION, VENTING, REMOVAL OR REINSTALLATION COSTS ARE NOT COVERED BY THIS WARRANTY.**

THE WARRANTY PRINTED ABOVE IS THE ONLY WARRANTY APPLICABLE TO THE PRODUCT. ALL OTHER WARRANTIES, EXPRESSED OR IMPLIED, INCLUDING, WITHOUT LIMITATION, THE IMPLIED WARRANTIES OF MERCHANTABILITY AND FITNESS FOR A PARTICULAR PURPOSE, ARE DISCLAIMED. IT IS UNDERSTOOD AND AGREED THAT AES'S LIABILITY UNDER THIS WARRANTY SHALL BE LIMITED TO THE PROVISION OF REPLACEMENT PARTS AND SHALL NOT INCLUDE LIABILITY FOR SPECIAL, INCIDENTAL OR CONSEQUENTIAL DAMAGES. ANY ACTION BROUGHT UNDER THIS WARRANTY MUST BE BROUGHT WITHIN ONE YEAR OF THE ACCRUAL OF THE CAUSE OF ACTION AND MAY ONLY BE BROUGHT IN THE CIRCUIT COURT OF MCCLLOUD COUNTY, MINNESOTA.

Some states do not allow limitations on how long an implied warranty lasts or the exclusion or limitation of incidental or consequential damage, so the above limitations may not apply to you. This warranty gives you specific legal rights, and you may also have other rights which vary from state to state.

**ALL WARRANTY CLAIMS MUST BE SUBMITTED IN WRITING THROUGH THE PLACE WHERE THE PRODUCT WAS PURCHASED.** In the event where the place of purchase has ceased business or if you feel that there is a legitimate reason that you

cannot submit your claim to the place where the product was purchased you may make a written request to the factory by emailing your request along with all of the required information to [technical@magnumheat.com](mailto:technical@magnumheat.com) . **NOTE: Verbal requests will not be recognized. If it is determined that warranty could have been performed by the place of purchase, the factory will deny the claim.**

Included with the claim must be the following information: (if this information is not complete, the claim will be denied)

Name, address, telephone number, email address, of place of business where product was purchased & also purchaser contact info.

Date of purchase, model and serial number of product, digital pictures of product (front, sides, back, venting inside and outside)

(If there is ductwork, there must be digital pictures of entire ductwork installation, static pressures, air flow measurements, and contact information of licensed/factory certified contractor that installed unit)

Nature of defect, what has been serviced (service record), who installed product along with contact information.

Mountain View Hearth Products  
manuals.stove-parts-unlimited.com

**American Energy Systems, Inc  
150 Michigan Street SE  
Hutchinson, MN 55350**

-----  
**WARRANTY INFORMATION**

Name \_\_\_\_\_

Address \_\_\_\_\_ City \_\_\_\_\_

State: \_\_\_\_\_ Zip \_\_\_\_\_ Phone Number \_\_\_\_\_

**Authorized Dealer** \_\_\_\_\_

Dealer Telephone #: \_\_\_\_\_

**Date Purchased:** \_\_\_\_\_

**Model No#** \_\_\_\_\_ **Serial No#** \_\_\_\_\_

**Installed By:** \_\_\_\_\_

**Trained By:** \_\_\_\_\_

**NOTE: FILL OUT THE ABOVE WARRANTY INFORMATION AND KEEP THIS COPY FOR YOUR PERSONAL RECORDS. REGISTRATION OF THIS WARRANTY CONSTITUTES YOUR ACCEPTANCE OF ALL TERMS CONTAINED THEREIN.**

# INSERT INSTALLATION PROCEDURES

## FACTORY BUILT FIREPLACES

Country Flame catalytic stoves are approved for installation in factory built wood burning fireplaces. Any fireplace used to install a Country Flame catalytic stove should be listed to UL 127 or ULC S610 standards. Further, Country Flame stoves have been specifically tested and approved for installation in the following manufacturer's fireplaces: Heatilator, Superior, Preway, Marco, Majestic, Martin. The approval to install one of Country Flame's stoves in one of these manufacturers' fireplaces extends to all models if it meets one condition. A minimum clearance (air space) of 1" (25mm) is to be maintained from the sides, back and top between the zero clearance fireboxes and the Country Flame catalytic stove once installation has been completed. Only two modifications may be made to any zero clearance fireplaces before installing a Country Flame catalytic stove:

1. The damper may be removed from the existing fireplace. If the damper is not removable, it must be permanently wired into the open position before the catalytic stove is installed and,
2. The ember catcher, located in the base of the fireplace flue, may be permanently removed before the catalytic stove is installed.

NOTE: Any parts removed from an existing fireplace should be properly stored. In the event the catalytic stove is removed, these fireplace parts would need to be reinstalled. Failure to reinstall a removed part will create a dangerous situation during fireplace operation.

## MASONRY BUILT FIREPLACES

Country Flame catalytic stoves are approved for installation in masonry built fireplaces constructed in accordance with the requirements of the Standard for Chimneys, Fireplaces, Vents, and Solid Fuel Burning Appliances in accordance with NFPA Number 211, UBC 37 standards, or any applicable local code requirements. Carefully plan the installation in order to avoid costly mistakes. First, be sure to understand clearance requirements and ensure the Country Flame catalytic stove model selected for the home will fit into an existing masonry built fireplace. An installation in masonry built fireplaces requires that the damper be secured into the open position. Although Country Flame catalytic stoves have been approved for "face seal" installation only, Country Flame STRONGLY recommends the use of one of the following techniques when deciding on a chimney connection:

- **GOOD** – Minimum of 12" (300mm) starter pipe installed into fireplace flue.
- **BETTER** – Direct connection of a chimney liner past the first clay flue tile in
  - accordance with NFPA 211 or any applicable local code.
- **BEST** - Install a complete relining of the masonry chimney system with an 8"
  - (200mm) diameter standard steel chimney connector.

Kits are available to assist in the connection of a catalytic stove to a masonry fireplace chimney. Look for a listed kit, which means it has agency approval. The stove to fireplace kit is to be installed in place of the fireplace damper. In most cases, the existing fireplace damper will be removed to allow for installation of the kit adaptor. The critical points are that: (1) The stove connector pipe (either 6" [150mm] or 8" [200mm]) must extend up the masonry chimney past the first clay flue tile and (2) The adaptor and chimney connector must fit tightly and be sealed with high temperature furnace cement. The adaptor kit's instructions must be followed over any information provided in this manual.

**DO NOT REMOVE BRICK OR MORTAR FROM THE FIREPLACE IN ORDER TO INSTALL ANY STOVE OR ADAPTOR KIT. FIREPLACE INSERT FLOOR PROTECTORS MUST EXTEND AT LEAST 8" (200MM) TO EACH SIDE AND 18" (450MM) IN FRONT.**

Have the masonry fireplace inspected by a certified installer or chimney sweep. Inspect for loose mortar, cracks, broken clay liners, deterioration, blockage of the flue, etc. The existing masonry chimney system should be certified for use with a catalytic stove. If the masonry chimney has an oversized flue, it will contribute to poor draft, creosote build up and

other problems. A chimney's flue size should be no less than the existing diameter of a stove's flue collar and no more than three (3) times the cross sectional area of the flue size of the catalytic stove's flue collar. **EXAMPLE:** Assume the stove's flue collar has an inside diameter of 6". This means the stove's flue area is approximately 28 square inches, which means the chimney's cross sectional flue area cannot exceed 84 square inches. Thus, if the clay tile inside the chimney has a dimension larger than 8" (200mm) by 8" (200mm) a full liner would need to be installed in the chimney flue to ensure proper stove draft. The installer should ensure that the proper size chimney tile is installed over the full length of the chimney. If not, install a properly sized liner to ensure optimal performance.

**DRAFT**

A good draft is necessary for the proper operation of any stove. Draft is the force created as warm flue gases move up the chimney and pull fresh air into the stove. Any restriction either at the exhaust or intake ends of the chimney will affect draft. The amount of draft in the chimney system depends on the length of the chimney, the local geography, nearby obstructions, prevailing winds, etc. A draft gauge should measure somewhere between 0.05 to 0.07 inches of water column (W.C.) for the stove to operate efficiently.

**MINIMUM CLEARANCES**

When installing a catalytic stove into an existing fireplace, ensure that all minimum clearances shown in FIGURE 7 and defined in TABLE 6 are maintained during installation. Failure to maintain these minimum clearances can create overheating of the fireplace, the stove, or surrounding combustible materials. Do not seal over the face of any chimney or air-cooling system of the existing fireplace system. Failure to maintain the proper clearances during installation voids the Country Flame warranty. Always refer to the Safety Label on the rear of the specific Country Flame stove being installed for the latest clearance and installation instructions.

**FIGURE 7: INSERT MINIMUM CLEARANCE REQUIREMENTS**

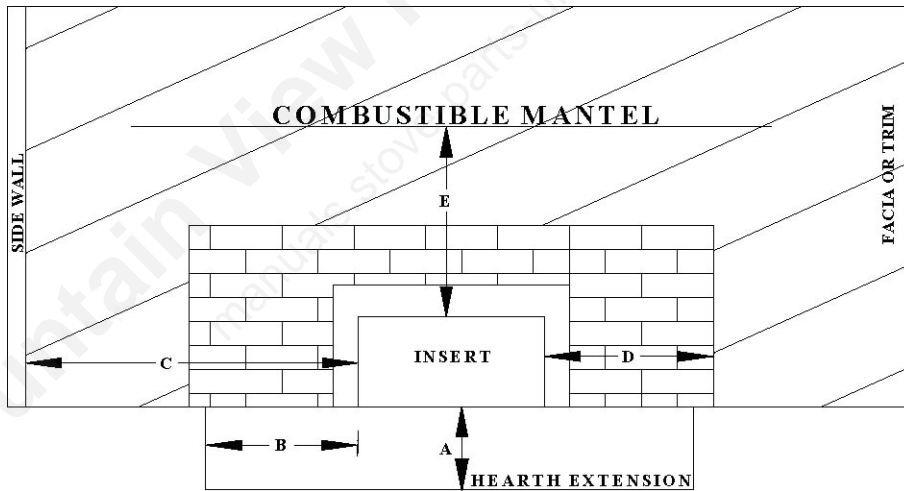

**TABLE 6: INSERT MINIMUM CLEARANCES, IN INCHES**

MODEL	A	B	C	D	E
O2	18"	8"	14"	8"	24"

**SHROUD AND TRIM INSTALLATION**

- Remove from box and verify all parts prior to installation.

- Push your Country Flame insert all the way back into the fireplace where it will be when fully installed. Double-check the location by measuring from both sides of the front of the insert to the edge of the hearth. These measurements must be the same in order to properly align the unit. The insert flue opening must be behind the lintel.

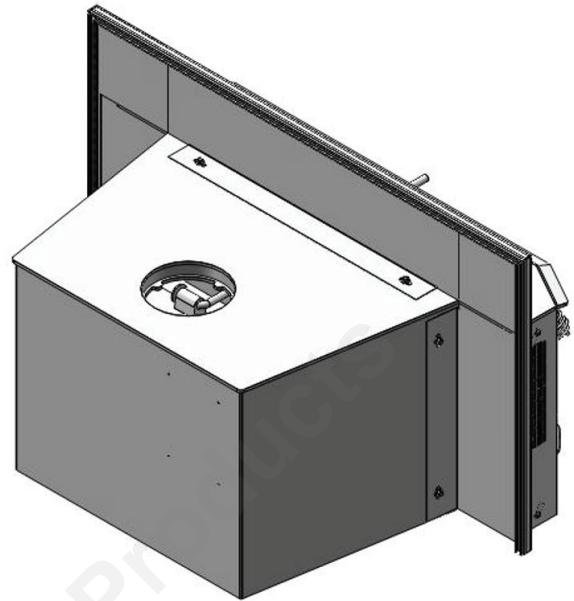

- After you have properly aligned the insert in the fireplace, you are ready to mark the trim panels for mounting. Pressing both right and left trim panels directly against the face of the fireplace. The trim panels are now in place as they will be when mounting is complete. While holding the trim panel in place, mark where the front edge of the panel fits up against the unit with a pencil. Do this to each side panel leaving the top trim panel for last because it will mount directly behind the 2 side panels.
- Pull the unit approximately 18"-20" back from the fireplace for mounting the trim panels. In this step you will align the front edge of the trim with the mark you had just made, and then mark the slots with a pencil. By marking the exact center of the slot you will have a slight adjustment up or down, depending upon the evenness of your fireplace.
- Place trim side panels along the line previously marked and insert your self-tapping screws and washers with a 3/8" adaptor and drill or drill 7/32" diameter hole. The tightening of the screws secures the trim panels firmly in place. Now position the trim top panel up tight against the trim side panel and insert the self-tapping screws and washer to secure the trim top panel the unit.
- Remove the backing from the roll of fiberglass insulation included in your trim panel box. Stick the insulation to the backside of the trim panels around the perimeter. This insulation will seal up against the face of the fireplace brick. For stone or irregular surfaces you may have to obtain additional fiberglass to fill the voids from you local building supply store. Very irregular surfaces with large voids may require masonry fill.
- Install the black or brass trim around the outside edge of the panels. Ensure the 2-angle brackets provided are installed on these black or brass trim. If the bottom of the side trim wants to pull away from the trim panels a small amount of silicone may be required on the backside of the trim to hold it in place during installation.

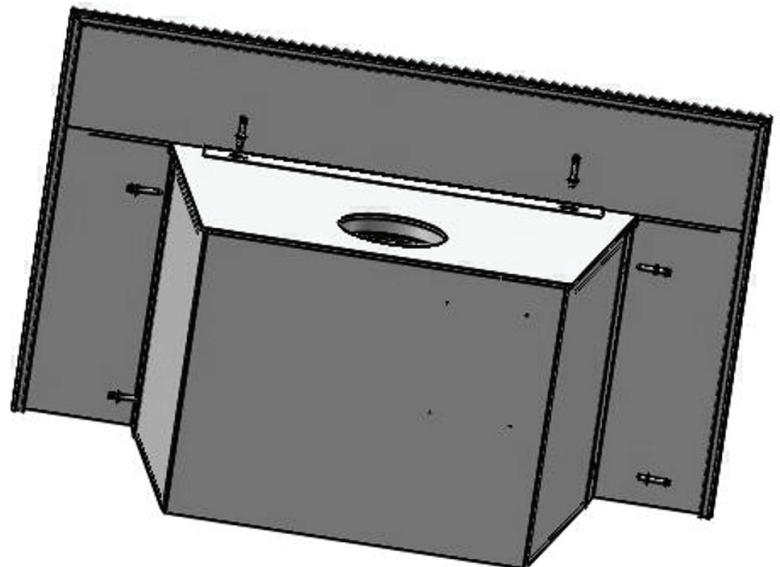

# MOBILE HOME INSTALLATION

**WARNING: Unit is not certified for mobile home installation.**

## MOBILE HOME RULES

1 Install only a HUD-approved laboratory tested stove in a mobile home. If the metal tag permanently affixed to a stove does not specifically state; “mobile home approved to HUD Standard UM-84,” do not install it in a mobile home.

## STOVE TERMINOLOGY

### STOVE COMPONENTS

Before installing and operating a catalytic stove, locate and identify all the controls and ensure a complete understanding of each. This manual has been organized to assist the installer during installation. This manual has been organized to assist the homeowner in operating and maintaining the catalytic stove at peak performance. Keep this manual and refer to it often.

### MANUAL DRAFT CONTROLS

1 A manual draft control is provided on each catalytic stove to assist in controlling the solid wood fuel burn rate. The manual draft control limits the fuel burn rate by metering the amount of combustion air entering the firebox.

2 All Country Flame catalytic stoves have manual draft controls. Refer to a specific model for the different locations of these controls.

3. Manual draft controls have nothing to do with the room air being heated and returned to the room. Manual draft controls are used to control the amount of combustion air available to the firebox.

a. **Model O2 Manual Draft Control Slides:** Refer to FIGURE 13 for the location of the two manual draft control slides on these models.

i. Slide each manual draft control slide toward the center of the stove. When slid all the way to the center, the slides allow maximum combustion air to be drawn into the firebox.

ii. Slide each manual draft control toward the outside of the stove. When slid all the way out, the slides allow minimal combustion air to be drawn into the firebox.

iii. **CAUTION:** Do not allow the manual draft control slides to remain fully open and the stove unattended for more than 30 minutes. In this state, the stove can overheat due to **OVER FIRING**. Over firing can cause a chimney fire or even worse, a house fire.

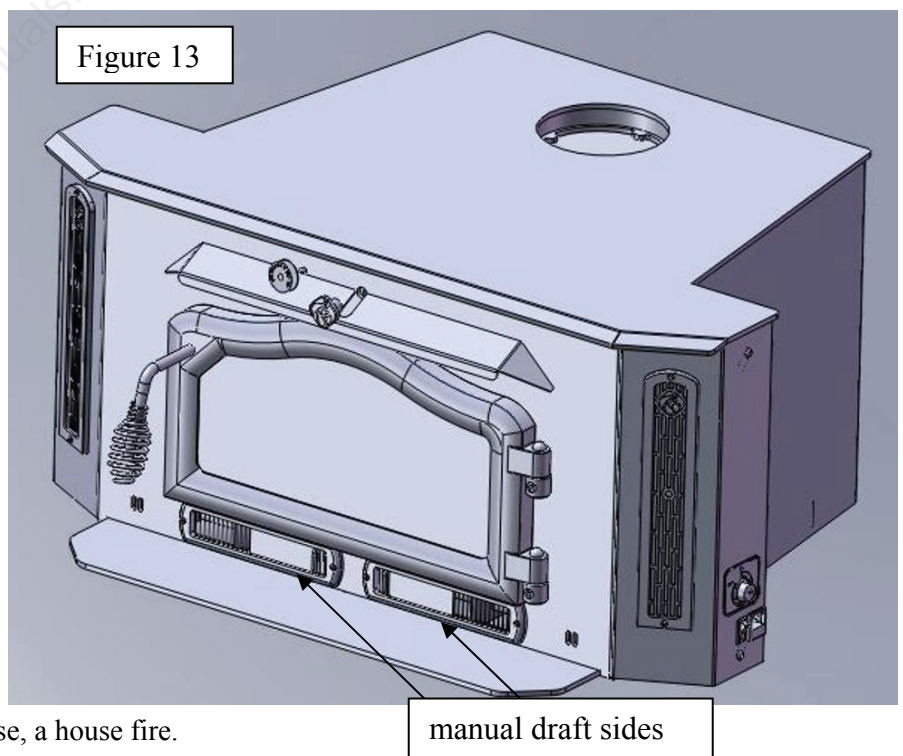

## CATALYTIC COMBUSTORS

Catalytic stoves contain catalytic combustors. Approximately 70% to 95% of the chemical energy contained in wood logs turns into heat as they are burned in a conventional stove (assuming optimal operation.) If smoke (flue gas) does escape up the chimney without being burnt, about 30% of the chemical energy is lost. This lost energy pollutes the chimney system and the atmosphere. The catalytic combustor was designed to make use of this wasted chemical energy. The combustor makes use of more of the chemical energy by ensuring flue gases ignite at lower burn temperatures; therefore, the catalytic stove has the potential to: a) reduce chimney creosote buildup, b) reduce air pollution, and c) reduce operating costs when compared to a conventional stove.

The catalytic combustor consists of a durable temperature resistant ceramic composition, which is extruded into a honeycomb shape. This ceramic material is then fired and covered with a noble-metal catalyst. As smoke from the fire contacts the combustor, it ignites at temperatures as low as 500° F. Flue gases normally ignite at 1,000° F. Country Flame recommends waiting until the probe thermometer reaches 700°F before engaging the catalytic combustor. (Catalytic operation, called “**light off**,” will not occur until the stove and catalyst exceeds 500°F to 700°F.) The Catalytic Bypass Rod must be disengaged to allow flue gases to bypass the catalytic combustors until the stove’s firebox reaches approximately 700°F, the temperature necessary to sustain combustor light off.”

## CATALYTIC BYPASS ROD

The catalytic bypass rod determines whether exhaust emissions travel up the chimney unimpeded or pass through the catalytic combustor to be cleaned on the way to the chimney. On Country Flame models, the catalytic combustor should be disengaged (pulled out on some models and pushed in on some models) when the fire is started. This allows combustion gases to bypass the catalytic combustors. As the stove reaches approximately 700°F the catalytic bypass rod should be engaged (pulled out on some models and pushed in on some models) thus closing off the flue and forcing all combustion gas to pass through the combustor. The catalytic bypass rod should always be disengaged when loading or reloading the stove with additional wood fuel.

## FIREBRICK REPLACEMENT

The intense repetitive heat inside the O2 firebox will normally cause hairline cracks in the Firebrick. Proper curing will assist to minimize these cracks and extend the life of the Firebrick. Small cracks will not normally diminish the effectiveness of the Firebrick; however, if large cracks develop in the Firebrick, then replacement of these items should occur. To replace the Firebrick bricks refer to Figure 6 and follow these simple steps:

ITEM NO.	PART NUMBER	DESCRIPTION	QTY
1	O2	Main Unit	1
2	O2-P44	4 1/2" x 8 9/16" Brick	4
3	O2-P45	1 5/8" x 8 9/16" Brick	2
4	O2-P43	1 5/16" x 9" Brick	2
5	PP-868	4 1/2" x 9" Brick	14
6	O2-P58	Brick Retainer Brkt	4
7	O2-P48	3 1/4" x 9" Brick	2

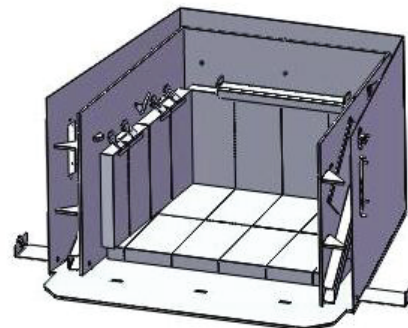
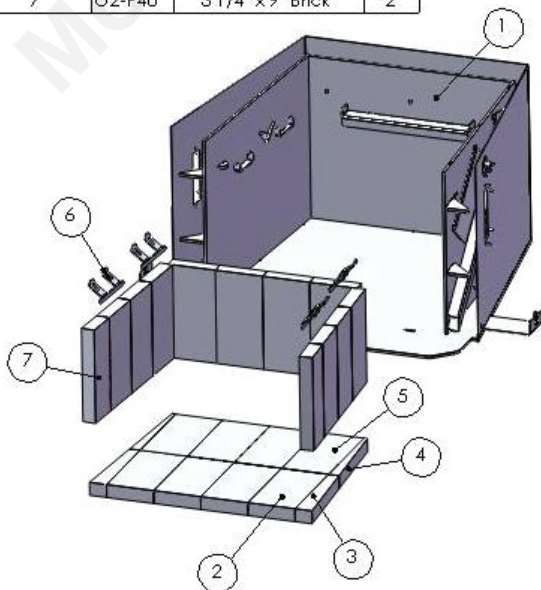

Faceplate and top removed for clarity

Install brick in configuration shown inside firebox. Keep bricks centered and snug against each other while installing. Slide item #7 clips down into brackets on the firebox walls and over top edge of bricks to lock.

## **BLOWER UNITS**

Blowers circulate room air through and around the catalytic stove to provide additional heating capability to the home. Refer to TABLE 5 and TABLE 6 to determine whether a blower is standard or optional on the unit purchased. The blower is designed to pull cool room air into and through the hot stove and back out into the room to provide additional heating value from the stove. Refer to blower specifications on a specific model for specific types and operation of each blower. A stove's firebox should reach proper operating temperature in order to minimize emissions and improve operating efficiency; therefore, a room air blower system should not be operated for at least 30 minutes after starting a fire. (This information is not applicable to catalytic stoves that do not include an optional blower system.)

## **8" PROBE THERMOMETER**

A probe thermometer is provided with each catalytic stove. This probe thermometer is used to measure the temperature at the catalytic combustor. Replacement probe thermometers are available from Country Flame or a local authorized dealer. The probe thermometer is installed directly above the hood and slightly to the left of the air bypass damper on the top left face of the stove. Refer to FIGURE 15 for the proper location of the probe on the face of the stove.

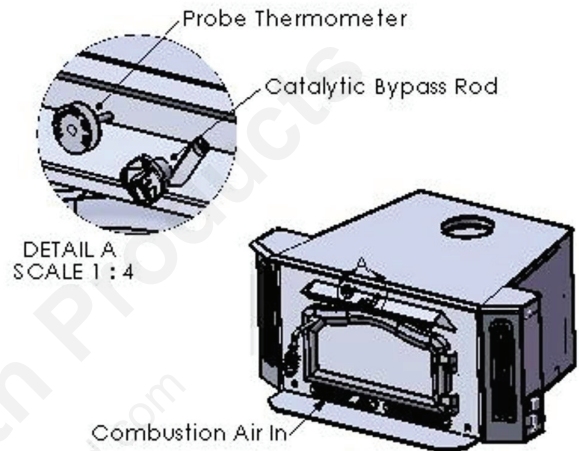

**FIGURE 15: PROBE THERMOMETER**

- 1 The probe thermometer is used to determine when to close the catalytic bypass rod.
- 2 The probe thermometer displays the temperature measured above the front combustion exhaust and over the catalyst combustor inside the firebox.
- 3 **NOTE:** A PROBE THERMOMETER IS NOT AFFECTED WHEN A BLOWER (OPTIONAL ON SOME MODELS) IS ENGAGED.
- 4 Any blower that is operating on a specific model will NOT influence temperatures in the firebox or catalyst regardless of the impact on the probe thermometer.

## **WOOD FUEL REQUIREMENTS**

1. Country Flame's catalytic stove models have been approved for use only with natural dry forest cut wood. Burning unapproved materials will damage or destroy the catalytic combustor and invalidates the Country Flame warranty.
2. Do not burn pressed logs or particleboard or any other construction material, as the bonding agents or kiln-dried wood can damage the catalytic combustor.
3. Uncured or green wood will cause creosote buildup in the chimney, plug the catalyst, and provide little in the way of heat.
4. Well-seasoned wood will improve the heat output of the stove. Fresh cut wood can contain over 80% moisture and this moisture content should be reduced to less than 20% moisture before the cut wood is considered "fuel."
5. "Seasoning" wood is the most appropriate and lowest cost method of reducing moisture content in cut wood. Ideally, cut wood's moisture content should be somewhere between 11 to 20%. Moisture meters are available for checking cut wood moisture content but other methods can be used to determine or ensure appropriate wood moisture content.
6. Softwoods should be seasoned from six to eighteen months. Hardwoods should be seasoned from 12 to 24 months. Logs that are 5" or greater in diameter need to be split in half, logs that are 8" or greater in diameter need to be split in thirds, and logs that are 12" or greater in diameter need to be split in fourths. Even trees that are found in forests and have been felled or broke off for several years will still require splitting and seasoning before they are used.
7. Store wood in uniformly stacked rows with walking space between each row. Store the wood elevated off the ground. All of this allows for good air circulation around the stack. Do not stack cut wood against a building or against any wall.

**REMEMBER:** Wood is one critical element of a complete stove heating system. Failure to select a proper grade of wood fuel, failure to store wood fuel properly, or failure to maintain wood fuel in a dry state will lead to reduced stove efficiency and increased maintenance and operational costs

## **CHIMNEY**

Chimneys come in two basic varieties:

- a) Masonry, as shown in FIGURE 16.
- b) Factory Built, as shown in FIGURE 17

**NOTE:** Refer to the Chimney appendix for detailed information on chimney construction and venting techniques.

Whether masonry or factory built, chimneys are used to ensure proper venting in order to remove combustion exhaust gases from the stove to the air outside the home. A chimney uses the fact that hot gases are light and therefore rise up through the chimney thereby creating a DRAFT. Chimney draft is dependent on many factors. Three important factors are: a) the height of the chimney, b) the quality of the chimney construction (no leaks), and c) a properly dimensioned chimney when compared to the stove being connected to the chimney.

The performance of a stove, as a heating system, is heavily dependent on the quality of the chimney system. Chimney systems have to meet stringent requirements in both the United States and Canada. For the model O2, use chimney connectors (pipe) with an outside diameter of 6" (150mm). Country Flame requires the use of a properly designed chimney that is approved or listed with regulatory agencies.

Prefabricated chimney pipe must be UL 103 listed and be HT 2100 rated. Chimney components, such as the chimney base, chimney fire stop (as required), chimney attic insulation shield, chimney-insulated tee, etc. are all required to be listed components and purchased from the same manufacturer where the chimney connector was purchased. These listed ancillary items are necessary to guarantee a proper, safe, and complete chimney system installation. CAUTION: Do not mix and match different manufacturer's chimney components. Once a single chimney component is selected, stay with that specific manufacturer and follow all the chimney manufacturer's installation requirements. ALWAYS follow a specific chimney manufacturer's installation instructions to exacting detail regardless of information provided from other sources. If there is any discrepancy that requires clarification, please contact Country Flame or a local dealer for assistance. Country Flame's warranty requires a properly installed and listed chimney system.

## **CHIMNEY CONNECTOR**

Chimney connectors are also commonly referred to as chimney pipe. Follow the specific chimney manufacturer's installation instructions for proper installation. It is important to ensure a good tight seal and proper installation of the chimney pipe in order to obtain proper chimney draft once the chimney is completed and the stove is operational. The chimney pipe should have a 6" (150mm) outside diameter for the model O2. The chimney connector should be constructed of a minimum of 24 MSG black or 25 MSG blue steel. The use of high temperature RTV sealant and self-tapping screws will be required to attach different sections of chimney connectors together and ultimately to the stove.

## **FLUE TRANSITION**

Many catalytic stove inserts have chimney connections that do not align with an existing chimney system. In order to make the installer's job easier, Country Flame provides standard flue transitions (offsets) that make the installation of a stove simpler. The use of high temperature RTV sealant and self-tapping screws will be needed to secure and seal the flue transition properly to the stove and chimney system. Contact Country Flame or one of its locale authorized dealers to obtain more information about flue transitions.

## **WALL THIMBLE**

A wall thimble is a manufactured or site-constructed device installed in combustible walls and ceilings through which the chimney pipe passes as it is routed through the house. The wall thimble is designed to ensure that combustible wall material does not self-ignite due to continuous, radiated and sometime excessive heat generated through the chimney. The wall thimble is a safety device that prevents wall or house fires.

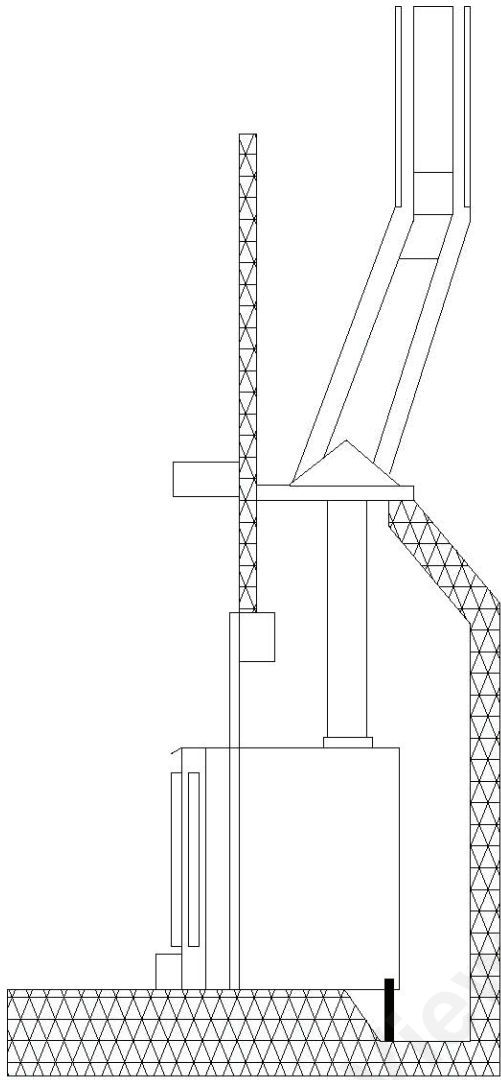

**FIGURE 16: MASONRY CHIMNEY**

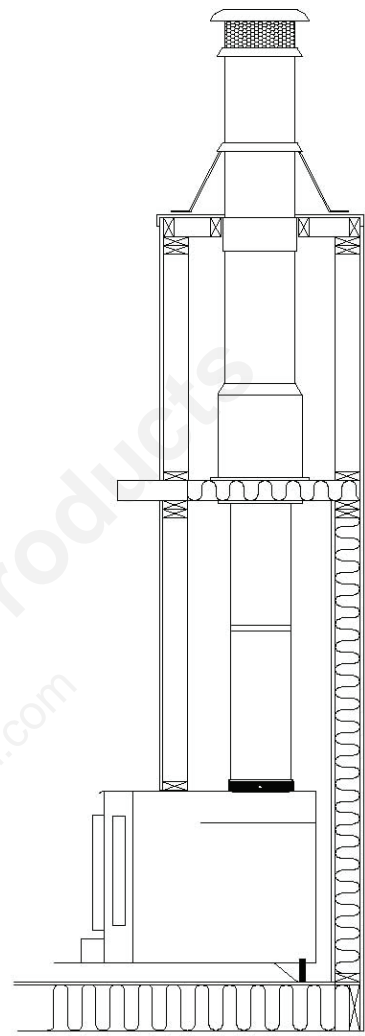

**FIGURE 17: PREFABRICATED CHIMNEY**

## MODEL O2 (INSERT ONLY)

The Country Flame Model O2 catalytic wood stove is manufactured for use in insert applications only. The Model O2 comes with dual room air blowers. These blowers are mounted one on each side of the stove. These blowers provide efficient heating and movement of room air. The Model O2 can handle 20-inch cut wood logs. Its firebox can be loaded with 2.1 cubic feet of cut wood logs. The stove's firebox is made from 5/16-inch thick steel. Some of the stove's firebox parts are made from 1/2-inch thick steel. This stove weighs over 400 pounds. The large stove door allows for viewing of a beautiful wood fire. The Model O2 improves the efficiency of any existing masonry or manufactured fireplace where it is installed.

Install the Model O2 into a) an approved and listed masonry fireplace or b) a zero clearance fireplace. The Model O2 is the only catalytic stove that is approved and listed as an insert for all factory built fireplaces. The Model O2 installation must maintain a minimum clearance of 1" (25mm) air space between all sides, back and top from the zero clearance firebox walls. Do not remove any brick or mortar in order to install a Model O2 as an insert into a masonry fireplace. For installation of a Model O2 catalytic stove into a zero clearance factory, built fireplace only two modifications are allowed:

- 1 The fireplace damper may be removed where the Model O2 is to be installed and,
- 2 The ember catcher located in the base of the fireplace flue may be permanently removed before the O2 is installed.

Refer to the MODEL O2 (Insert only) section to obtain specifications for the Model O2 insert. In the event additional information is required and not covered by this manual, please contact Country Flame or an authorized local dealer. If the Model O2 is installed in a factory built fireplace, use the fireplace manufacturer's clearance requirements or the O2 clearances, whichever provides the greatest clearance. Always refer to national and local codes. Refer to the Safety Label on the rear of the stove for the latest clearance and installation instructions before installation. Refer to FIGURE 7 and TABLE 6 to ensure all minimum clearances are properly maintained during installation. Failure to maintain these minimum clearances can create overheating of combustible materials. Failure to maintain the proper clearances will void the Country Flame warranty. Install the Model O2 insert with a minimum of a) 14 inches of clearance to combustible sidewalls, b) 2 inches of clearance to the fireplace cavity walls, and c) 24 inches of clearance from the top of the Model O2 insert to the bottom of any combustible mantel.

Floor protection must be provided from a listed floor protector or any other equivalent non-combustible material. A listed floor protector must a) have a minimum of an "R" value of 2.0, b) extend a minimum of 8 inches from the stove opening to each side of the unit, and c) extend a minimum of 18 inches as measured from the face of the Model O2 insert. Model O2 insert applications require that any hearth extension that was supplied as part of the zero clearance fireplace installation or part of an existing masonry fireplace must be used; however, there must always be a minimum of 18 inches (450mm) of floor protection in front of the Model O2 insert as measured from the face of the insert. Use a listed floor protector with a thermal conductivity of  $K = 0.85$  Btu – inches per square foot per hour per degree Fahrenheit and equivalent to 3/8" (9.4mm) non-asbestos millboard.

During stove shroud installation, never block any of the zero clearance fireplace vents with the Model O2 shroud. Refer to the shroud section. If there are questions, please contact Country Flame or one of its authorized local dealers.

Refer to APPENDIX G for information on venting and chimney requirements.

## MODEL O2 (INSERT ONLY) CATALYTIC STOVE (GOLD PACKAGE SHOWN)



A Country Flame Model O2 catalytic stove is approved as a fireplace insert both in the United States and in Canada. The Model O2 catalytic stove has been tested to UL 1482 (United States) and CAN/ULC-S628 (Canada) standards.

The Model O2 catalytic stove must be connected to a code-approved masonry chimney or a listed factory-built fireplace chimney with a direct flue connector inserted into the first chimney liner section.

The Model O2, as well as all Country Flame catalytic stoves, shall not be operated with an elevated fire. Do not use grates or any other items to elevate the fuel. Burn the wood fuel on the existing refractory brick supplied with the stove.

Country Flame catalytic stoves are to be operated with the door in the fully closed position at all times except during refueling. Always open the damper before opening the door to refuel a stove.

The O2 blower has a by-pass switch for testing the blowers in a “stove cold” condition. Once the stove heats up, the switch is bypassed by the snap disk.f

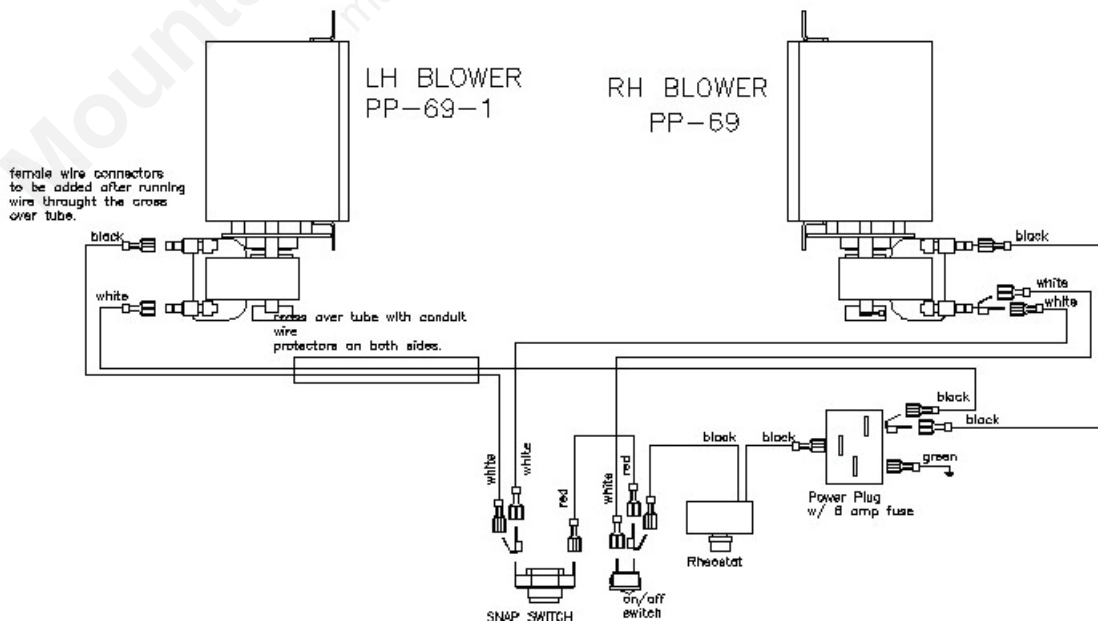

## MODEL O2 SPECIFICATIONS (INSERT ONLY)

<b>INSERT HEIGHT</b>	17.5" / 445 mm
<b>INSERT DEPTH</b>	25" / 635 mm
<b>WIDTH AT FRONT</b>	27.25" \ 37.75" / 692 mm \ 959 mm
<b>WIDTH AT FIREPLACE OPENING</b>	18.75" / 476 mm
<b>SHROUD WIDTH</b>	42.5" / 1080 mm
<b>SHROUD HEIGHT</b>	24" / 152 mm
<b>WIDTH AT REAR</b>	22" / 559 mm
<b>HANDLE DEPTH</b>	7.5" / 184 mm
<b>HEARTH EXTENSION</b>	Adjustable
<b>FLUE SIZE, I.D.</b>	6" / 152 mm
<b>DEPTH TO FLUE CRT</b> (From back of stove)	6.0625" / 154 mm
<b>WEIGHT WITH BRICK</b>	422 pounds / 192 kg
<b>EPA EFFICIENCY</b>	72%
<b>EPA BTU RANGE</b>	10,800 to 34,100
<b>COMBUSTION AIR CONTROL</b>	Manual
<b>EMISSION RATE (grams/hour)</b>	3.0
<b>LOG LENGTH, MAXIMUM</b>	20" / 508 mm
<b>FIREBOX VOLUME</b>	2.1 cubic feet
<b>BLOWER ASSEMBLY</b>	2 each, blower fans

**WARNOCK HERSEY TEST REPORT 632-111900**

NOTE: ALL SPECIFICATIONS PROVIDED ARE APPROXIMATE AND SUBJECT TO CHANGE WITHOUT NOTICE.

## APPENDIX A: REPLACEMENT PARTS DESCRIPTION

<b>CATALYST PARTS</b>		
CF-108	O2	Catalyst Stainless Steel Deflector Shield
PP-516	O2	Catalyst Holder 7" Round
PP-518	O2	Catalyst 7" Round
PP-31	All Catalytic Stoves	Thermometer Probe
<b>DOORS</b>		
CF-2300	O2	SD-1 (PP-44) Cast Door Assembly
CF-2310	O2	SD-1 (PP-44G) Gold Door Assembly
CF-2320	O2	SD-1 (PP-44N) Nickel Door Assembly
<b>ELECTRICAL</b>		
MF3537	O2	Heat Sensor 110
PP-988	Wood/Pellet	Power cord
58-0022-00	O2	Switch - High/low Rocker switch
PP-1013	All Stoves	Wire: Black 18 gauge wire (ft)
<b>REFRACTORY BRICK</b>		
O2-P43	O2	O2 firebrick - takes 2 (ea)
O2-P44	O2	O2 firebrick - takes 4 (ea)
O2-P45	O2	O2 firebrick – takes 2 (ea)
O2-P48	O2	O2 firebrick – takes 2 (ea)
PP-868	O2	O2 firebrick – takes 14 (ea)
O2-58	O2	O2 bottom firebrick - takes 4 (ea)
<b>GLASS</b>		
PP-49	O2	17 1/2 x 8 1/2 plain - SD1
PP-50	O2	17 1/2 x 8 1/2 etched - SD1
PP-1270	All Models	8-32 x 3/8" machine screw – takes 6 ea.
PP-412	All Models	1/2" x 7/8" glass clip – takes 6 ea.
<b>GASKETS</b>		
R0082		1/8 x 3/4 glass tape - per ft. need 4.0 ft
PP-87		3/4" door rope - per ft. need 4.5 ft.

## HANDLES & KNOBS

---

P003087		Washer Flat ½" – takes 2 (ea)
PP-36	G-100, All wood, Exc. NC-6	Brass threaded Flame Logo
CF-175	All Stoves	Steel Door Handle Rod
CF-177	All Stoves	Cam Lever for Door
PP-37	O2, FP, R, NPS	Charcoal Logo "Country Flame"
P7544		Jam Nut ½-13 – takes 2 (ea)
PP-414-Black		Spring Door Handle Large Black
PP-414	All	Spring Door Handle Large Brass
CF-350	All Stoves	Steel Door Handle Assembly (Includes rod handle, spring, cam, nuts & washers)

## HARDWARE

---

PP-408	All Stoves	Auto Clip – takes 2 (ea)
PP-33		Hinge Pin Cap - Brass
PP-34		Hinge Pin Cap – Nickel
PP-38		Hinge Pin Cap – Black
PP-157	All Stoves	Nut for Door Handle (requires 2)
O2-4200	O2	O2 Adjustable Leveling Legs (2 per Set)
PP-440		Screw Black 8/32 X 1 for Trim
PP-439		Screw Black 8/32 X 3/4 for Trim
PP-163		Screw Brass 8/32 X 1 for Trim
PP-162		Screw Brass 8/32 X 3/4 for Trim
PP-406		Set Screw for Logo & Auger Collar & 500 FPD
PP-146	All Stoves	Washer for Door Handle (requires 0 - 5)

## INSULATION

---

PP-220	All Inserts, FPD	Insulation stove kit - shroud
--------	------------------	-------------------------------

## MOTORS

---

PP-69 O2, OV-26BF-I	O2 Blower - LH
PP-69-1 O2, OV-26BF-I	O2 Blower - RH

## OWNER'S MANUAL

---

PP-400-02	Owner's Manual, O2 Catalytic
-----------	------------------------------

## TRIM & GRILLS

---

CF04-T-B	Trim Kit Black
CF04-T-G	Trim Kit Gold
CF-221 BBF, O2	Air Slide - Black - each
BTK-SLIDE	Air Slides Assembly Kit Black
GTK-SLIDE	Air Slides Assembly Kit Gold
O2-9200B	Standard Shroud w/ black trim
O2-9200G	Standard Shroud w/ gold trim

O2-9210B	Oversized Shroud w/ black trim
O2-9210G	Oversized Shroud w/ gold trim
O2-9200-T	Std Top Shroud O2
O2-9200-L	Std LH Shroud O2
O2-9200-R	Std RH Shroud O2
O2-9200-P01B	RH Standard Shroud Trim O2 BLK
O2-9200-P01G	RH Standard Shroud Trim O2 Gold
O2-9200-P02B	LH Standard Shroud Trim Blk
O2-9200-P02G	RH Standard Shroud Trim O2 Gold
O2-9200-P03B	Top Standard Shroud Trim Blk
O2-9200-P03G	RH Standard Shroud Trim O2 Gold
O2-9210-T	Oversized Top Shroud O2
O2-9210-L	Oversize LH Shroud O2
O2-9210-R	Oversize RH Shroud O2
O2-9210-P01B	RH Oversize Shroud Trim O2 BLK
O2-9210-P01G	RH Oversize Shroud Trim O2 Gold
O2-9210-P02B	LH Oversize Shroud Trim Blk
O2-9210-P02G	RH Oversize Shroud Trim O2 Gold
O2-9210-P03B	Top Oversize Shroud Trim Blk
O2-9210-P03G	RH Oversize Shroud Trim O2 Gold

## **APPENDIX B: OPERATION & MAINTENANCE GUIDE**

### **FIRST FIRE, STEP 1**

Please read and understand this manual before installing, operating, or attempting to maintain a Country Flame Catalytic Stove. Failure to follow instructions, warnings, or understand safety issues may result in property damage, bodily injury or even loss of life.

### **FIRST FIRE, STEP 2**

All Country Flame catalytic stoves are approved to burn natural untreated properly seasoned wood fuel. Any other fuel, such as coal, synthetic logs, plywood, paint, particleboard, chemical lighters, or chemically treated fuel may produce poison gas and will ruin the catalyst combustor inside the Country Flame stove. The catalyst is designed for burning dry seasoned wood. When operated properly, the catalyst will ignite gases whose temperatures can approach 2,000 F and the catalyst will turn cherry red with heat. If any parts of the steel stove or chimney system turn red, immediate action is required in order to slow down the burn rate and prevent over firing. As temperatures drop, the catalyst will continue to function properly long after the red glow is gone.

### **FIRST FIRE, STEP 3**

Before a fire is started in the stove, become knowledgeable with all stove controls associated with a specific catalytic model. Different catalytic models operate differently. On some stoves, pushing in on the catalyst rod may disable the catalyst while on other models pulling out on the catalyst rod may disable the catalyst. Whether you have experience with a catalytic stove or this is a new experience, it is imperative that the operator know how to control the stove in all situations and be prepared to react to any situation.

**KNOWING WHERE THE STOVE CONTROLS ARE, WHAT THEY DO, AND HOW TO OPERATE THESE CONTROLS IS CRITICAL TO SAFE AND PROPER STOVE OPERATION. REFER TO THE SPECIFIC STOVE SECTIONS AND ENSURE THOROUGH KNOWLEDGE OF EACH CONTROL BEFORE CONTINUING TO START THE FIRST FIRE.**

### **FIRST FIRE, STEP 4**

In preparing for the first fire, ensure that the controls are set as follows:

- 1 Set the combustion air controls wide open. This allows for maximum airflow into the firebox to create maximum draft as a fire starts.
- 2 Ensure that the catalyst bypass rod is set such that the catalyst is bypassed during fire startup. Once the stove has reached around 500 F to 700 F, the catalyst will be engaged to ensure a cleaner, hotter, and more efficient burn occurs in the stove. Ensure that the 8" probe thermometer has been installed and is visible on the front of the stove. This thermometer provides critical information during stove operation.
- 3 Once a fire is started, the stove will warm quickly and controls may become warm if not hot to the touch. It is important to have a hot pad or insulated gloves available at all times so that controls can be adjusted regardless of their temperature.

### **FIRST FIRE, IGNITION**

- 1 Open the front door of the unit and build a small fire as defined in the following steps. It is important to keep the first couple fires small (less than ½ hour in duration) so that the stove and chimney system can be tested for any leaks, proper operation, and proper draft.

2 Place several pieces of wadded up newspaper between small pieces of seasoned kindling. Add a couple more pieces of wadded up newspaper and then add some small diameter wood, small dry kindling, or even rolled up newspaper. AGAIN, be cautious, as the amount of fuel put in will determine how long the fire burns. The first fire could just be some wadded up paper and kindling to determine how well the stove drafts and to determine if there are any “leaks” in the system.

3 Light an edge of the newspaper and close the stove door. The fire should spread quickly as the combustion air control is wide open allowing for an unlimited fuel-air mixture. As the stove warms up, the temperature of the probe thermometer should start to climb but should not exceed much over 400 °F to 500 °F due to the limited fuel and the fire should quickly burn out (unless a really large amount of fuel was put into the firebox.) Any smoke should be seen moving to the back-center-top part of the firebox as the exhaust gases rise up the chimney. NOTE: If the smoke builds up in the firebox or any smoke is seen coming out of the combustion air controls, ensure a window close to the stove is opened slightly to improve the stove draft. AGAIN, a chimney, in order to properly draft must be warm (hot air rises) so a flow of fresh air must be available to the stove. Ensure other house fans or other devices consuming air are not causing limited or negative pressure to the catalytic stove. As the stove temperature rises, the chimney system should become more efficient in removing unwanted exhaust gases as draft improves.

1 The stove should be completely cool before attempting to correct any problems discovered during the first fire or before repeating the first fire process.

2 The homeowner should be confident of both the understanding of the stove controls and a properly operating stove and chimney system before creating a large fire in the system.

### **DRAFT PROBLEMS**

1. Stove system draft problems may exist if any of the following systems are observed during the first few small fires:
  - a. Smoke enters the living area after the chimney has warmed up and a window, close to the stove, has been opened slightly.
  - b. The small fire’s burn rate was slow or the fire extinguished itself before burning up all material.
  - c. The chimney system may not have the proper clearances to obstructions with in the vicinity outside the home.
  - d. The geographical location of the house and chimney system causes a consistent downdraft.
  - e. The chimney system was pre-existing and has not been properly cleaned or has obstructions.
  - f. The chimney system, whether old or new, was not been properly sealed along the full length of the liner.

Leaks will reduce the amount of chimney draft.

1. After several attempts with small fires, if the homeowner suspects any of the problems above or even if they are not sure what the problem is, it may be necessary to call a certified chimney sweep and have them bring in equipment to measure the chimney draft. At a minimum, a chimney should draft between 0.05 to 0.07 inches of water column.

3. High tech stoves of all types are more sensitive to drafting problems. If a stove is 100% efficient, that means 100% of the heat is going into the home and no heat goes up the chimney. However, for a chimney system to work properly, the air entering the chimney must be heated so that it will rise and thus create a draft behind it. Some of these suggestions may help to remedy drafting problems.

- a. Open the catalytic bypass rod to open the flue damper before opening the stove door.
- b. Open the flue damper and combustion air slides anywhere from 30 seconds to 1 minute before opening the stove door. This will increase draft by heating the chimney thus keeping smoke or smoke smell from entering the house as more fuel is added to the fire.
- c. Turn off all vents or exhaust fans. Keep stove doors closed during normal operation. Only open the doors to refuel the stove. Verify that no other draft-robbing appliances are in operation. Slightly crack a door or window near your stove/insert to promote a good draft.
- d. In severe cases with inserts, a positive connection to the fireplace damper or to the top of the chimney may be necessary to correct leaks caused by broken or cracked tiles.

## FIRST LARGE FIRE

1. Repeat the small fire building process, ensuring that the stove controls are in the proper position to start a fire. As the firebox is filled with wood fuel, build on the size of wood that is put on top of the pile of kindling. The firebox can be filled with any amount and size of logs that the stove will handle.
2. Once the firebox has been filled, the newspaper can be lit and the stove door closed.
3. It is important to monitor the fire as it grows in size. If the stove is left unattended with the combustion air wide open and the catalyst bypassed, the stove can rapidly overheat, as there is nothing to control the rate of fuel burn with the controls set in the “startup” position. **DO NOT LEAVE THE STOVE UNATTENDED DURING FIRE STARTUP.**
4. Depending on the type of seasoned fuel, the amount of fresh air, and the chimney system, the stove should rapidly approach 500 F to 700 F. Country Flame recommends the catalyst bypass rod be closed around 700 F. By closing the catalyst bypass rod, the flue gases will now be forced to pass through the catalytic combustor thus increasing the temperature and slowing the burn rate. It is normal for the fire to diminish slightly as the catalyst will add a restriction to the amount of gases going up the flue. If it looks like the fire is going to go out, it may be necessary to bypass the catalyst and allow the stove gases to exhaust directly up the flue that again, should increase the size and rate of burn of the fire. Once the fire has been re-established and the temperature is at 700°F, the open flue should be closed through use of the catalyst bypass rod.
5. Should the fire diminish to the point of going out, the operator will need to consult the Troubleshooting Guide, contact the installer, or dealer for assistance if the problems persist.
6. Once a burn has been established and the catalyst is operating properly, the probe thermometer temperature can rise anywhere from 900 F to 2,000 F. The temperature will be determined by the quality of draft, the amount of combustion air available, the quality and volume of wood fuel available to the fire, and the setting of the controls.
7. After several large fires, the homeowner should feel comfortable in operating and monitoring the performance of a specific catalytic stove. By monitoring the stove’s temperature and adjusting combustion air slides, the homeowner should be able to achieve the burn time and heat output acceptable to them. The preceding statement assumes that all other factors affecting the stove’s operation are correct. NOTE: The catalyst is unaffected by the room air blower’s operation (optional on some units).
8. Surface thermometers are not accurate for monitoring interior stove temperatures. The probe thermometer is the only temperature that is accurate for making decisions on stove operation. Maintain the probe thermometer in good working condition to remove any stove operational guesswork. The outside portion of the slide (the last section to be covered as the slide closes) is called the Air Wash. It channels preheated combustion air into the firebox through long slots just inside the door opening on the top and sides.
9. Performance of a catalytic stove will vary according to many factors but draft is an important element. The homeowner may want to experiment as to when to close the flue and engage the catalyst to determine the best settings for desired performance. Country Flame recommends the homeowner experiment by engaging the catalyst at different temperatures and at different combustion air control settings. The homeowner may determine that 1,000 F is the optimum setting to close the combustion air control in their system. Bottom line: Do not be afraid to experiment but monitor results closely and **DO NOT OVER FIRE** the stove. If over firing occurs, immediately close all combustion air controls to reduce the air supply to the fire. Also, if not already operating, turn on the room air blower to pull heat away from the stove and surrounding area.
10. During stove operation, hot air sweeps over the front door glass. This airflow is designed to help maintain clean glass but continuous operation will result in regular glass cleaning issues. **REMEMBER:** Long slow burns will generate some creosote formation. A hot fire will assist in keeping the glass clean. Sometimes a chemical cleaner or a razor blade is necessary to remove the creosote from the glass. If the fire is hot before limiting the combustion air, the stove glass will remain much cleaner than if it is a cool fire. The hotter the fire, the cleaner the glass.

11. An ash bed is helpful in maintaining a hot fire in a catalytic stove. For maximum efficiency, allow an ash build up of 1 to 2 inches in the stove. **CAUTION: Never remove ash from a stove with the room air blower operating.** The airflow from the room air blower could scatter hot ash or hot embers across the room sparking a house fire!
12. Country Flame catalytic stoves are not equipped with automated thermostatic controls. This means the homeowner must gain the knowledge, confidence, and experience to adjust the combustion air slides on a specific stove in order to maintain a comfortable home temperature range. If the combustion air slides are opened fully, significant amounts of heat will be generated with increased fueling requirements and the stove will burn hotter and cleaner. If the combustion air slides are operated fully closed, a stove will generate very low amounts of heat with very long periods between refueling. This means the home will have lower average temperatures and the chimney system will build up creosote at a much faster rate.
13. It is important for the homeowner to understand what happens in the event enough combustion air is not available to a catalytic stove. Poor combustion, dirty chimney systems, and overall reduced performance will occur if an adequate volume of combustion air is not available during stove operation. Consult with a certified professional to ensure a specific home has both balanced and positive amounts of air present during stove operation.

### CARE OF STOVE GLASS

All Country Flame stoves use high temperature ceramic glass that is rated to 1400°F. If the glass should crack or break for any reason, it must be replaced with an equal or better grade ceramic glass. NOTE: THE MOST COMMON CAUSE OF GLASS DAMAGE IS DUE TO OVER TIGHTENING THE GLASS CLIPS THAT HOLD THE GLASS IN THE DOOR. The use of tempered glass or ordinary glass **IS NOT AUTHORIZED** for use in any Country Flame stove and is hazardous if used. All Country Flame stove replacement glass can be purchased from the Country Flame or through a local authorized dealer. DO NOT OPERATE any stove with a cracked or broken door glass or with a stove door in the open position.

### GLASS REPLACEMENT

If a door glass should crack or break for any reason, it must be replaced with an equal or better grade ceramic glass. Refer to FIGURE 18, remove the glass clips with a common household screwdriver, and store both the screws and glass clips in a safe place. These items will be required during reassembly so any damaged or worn items should be ordered and replaced to ensure the glass and door properly fit together. The use of tempered glass or ordinary glass **IS NOT AUTHORIZED** and is hazardous to use. Refer to APPENDIX A for the specific part number and a specific size of glass for a specific model catalytic stove. Be prepared to provide the stove model number, stove serial number, the glass part number, and whether etched or non-etched glass is required when reordering. Cutting or trimming the replacement glass is not required. Replacement glass should fit into a specific catalytic stove door without any modification. Replacement glass can be purchased from Country Flame or a local authorized dealer. It is important that when glass or any other stove component is replaced that reinstallation of said component(s) include the proper gaskets and clearances provided when the stove was originally manufactured. If there is any question about installation procedures, proper clearances, required gasket material, or the latest techniques in maintaining a stove in perfect operating condition, please contact Country Flame or one of its local authorized dealers.

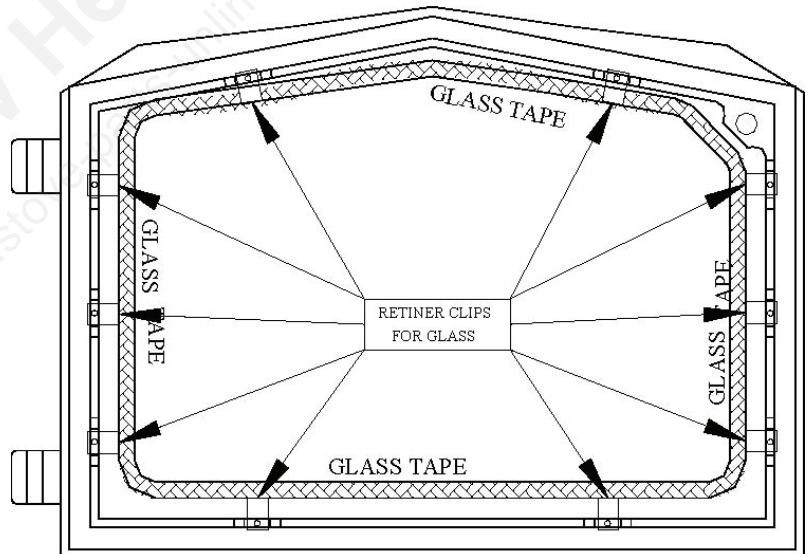

**FIGURE 18: DOOR GLASS REPLACEMENT**

## GLASS-CERAMIC SPECIFICATIONS

Manufacturer: **Euro Kera** Window Type: **Glass-Ceramic, Kera Lite®**

**KERA LITE®** glass-ceramic has a thermal endurance far exceeding that of normal tempered glass. **KERA LITE®** is designed to operate at temperatures ranging from **-400°F to +1400°F**. Despite its superior thermal properties, **KERA LITE®** stove windows should be treated with care. This glass-ceramic can still be scratched or broken by mechanical abuse. When cleaning the window, use only non-caustic, nonabrasive cleaners. Country Flame uses **KERA LITE®** glass-ceramic that is 0.197 inches thick +/- 0.008 inches. The **KERA LITE®** glass is custom cut to fit Country Flame stoves. If problems occur with stove glass, contact Country Flame or an authorized local Country Flame dealer for assistance.

## GLASS-CERAMIC CLEANING

**NEVER ATTEMPT TO CLEAN HOT STOVE GLASS.** Applying cleaner to hot glass may cause burns, emit hot noxious fumes, and will increase the chances the glass will stain. Creosote and soot that attaches to the glass, caused by burning wood fuel, may be removed with Speedy White Hearth and Stove Cleaner or Cook Top Cleaning Crème available at appliance centers or call 1-800-872-8855 to obtain the proper cleaning material. **BE CAREFUL**, the cleaning solution can stain surrounding material, especially after the creosote has dissolved and runs or drips off the glass. Hint: put down a generous amount of newspaper in the surrounding area. After using any cleaner always remove all residue by washing the glass with water or conventional window cleaner spray. Any remaining residue will stain the glass when it is heated. The glass door on a Country Flame stove provides the enjoyment and beauty of viewing the fire while retaining the efficiency of your stove. Although the brand of glass used in the Country Flame door has well established and recognized heat resistant and strength characteristics, it can be broken through improper use. To achieve the maximum utility and safety of your glass door, Country Flame advises the homeowner to observe the following use and safety tips:

1. Inspect the glass regularly for cracks or breaks. If you detect a crack or break, extinguish the fire immediately. Contact Country Flame or an authorized local Country Flame Dealer for glass replacement. **CAUTION: DO NOT OVER TIGHTEN GLASS CLIPS OR GLASS BREAKAGE WILL OCCUR.**
14. Do not slam the stove door or otherwise impact the glass. When closing the door, make sure that no logs or other objects protrude to impact against the glass.
15. Glass will require cleaning but several techniques are advised to reduce creosote buildup.
  - a. Pull your fire forward to intensify the heat near the glass.
  - b. Each Country Flame stove is equipped with a glass air wash system. Opening the combustion air slides slightly ensures enough air is entering the glass air wash system to be more effective.
  - c. Very long, slow fires starve the glass air wash system and hasten creosote buildup.
  - d. Trim the gasket around the glass if it has curled and is interfering with the flow of air over the inside of the glass.
16. Do not clean the glass with materials, which may scratch it (such as steel wool) or otherwise damage the glass.
17. The **Glass-Ceramic, KERA LITE®** used in Country Flame stoves is built to exacting standards and is expensive. Replacement costs are high so be careful, properly clean and care for this ceramic glass thus enjoying years of beautiful fire viewing.

## **DECORATIVE DOORS**

Optional doors are available from Country Flame for all catalytic stoves. The purchase of optionally decorated or plated doors in no way impacts the overall operation or efficiency of a stove. Optional doors are strictly decorative and provided to allow customers to meet a variety of home décor options. Today's plating technology is almost completely done outside the United States. This makes plated doors an expensive option. Damage of any kind to plated doors results in costly repairs that no one wants to pay for.

It is strongly recommended by Country Flame that homeowners follow the care and maintenance procedures for plated doors provided in this manual. Any damage that has been caused by misuse or improper cleaning techniques will not be the responsibility of Country Flame.

Gold or plated door should be wiped down regularly to ensure the luster and beauty of the door system lasts the life of the stove. Always use an approved glass cleaner (i.e. Windex, Glass Plus) and a lint free soft cloth to polish the doorframe. DO NOT use any abrasives, like steel wool, brass polish, cleaners, like comet, or other household cleaners. If these products are used on the plating, the door will be permanently scratched and the finish ruined. If damage does occur to the doors from improper cleaning, the solution will be expensive to return the doors to their original luster. The doors would have to be returned to Country Flame for refinishing. Country Flame can accomplish the repair of any door but it is expensive. Use proper care in cleaning plated and other plated surfaces and a lifetime of enjoyment will be yours. Cast doors require little or no care as long as abrasives are not used.

## **ROOM AIR BLOWER MAINTENANCE**

All Country Flame catalytic stoves come equipped with a room air blower or have an optional capability to install a room air blower. Before any room air blower is operated, some basic electrical safety precautions should be taken. The room air blower is like any other home appliance; it operates off standard household electrical voltages and currents. This means that if improperly installed, the blower will create conditions that can cause electrical shock or even death. Ensure that a certified electrician has reviewed or inspected the installation of the wiring system before operating the blower system.

**WARNING: ROUTE POWER SUPPLY CORD AWAY FROM THE STOVE. FAILURE TO OBSERVE THIS WARNING CAN LEAD TO A MELTED POWER CORD AND A SHOCK HAZARD.**

**WARNING: NEVER COVER CIRCULATING AIR INLETS TO THE STOVE BLOWER.**

**WARNING: MODIFYING THE BLOWER SYSTEM OR IMPROPERLY INSTALLING THE BLOWER SYSTEM WILL IMMEDIATELY VOID THE COUNTRY FLAME WARRANTY.**

**NOTE: STOVE BLOWER SYSTEMS HAVE MOVING PARTS THAT REQUIRE ROUTINE ATTENTION.**

Maintenance schedules will be affected by the use of the stove. Frequent to daily use will shorten the interval between maintenance intervals. Inspect the fan for routine cleaning and oiling to keep the blower system performing at optimal efficiency. At least once a year, the fan should be removed for cleaning. During cleaning it should be determined if lubrication of the electrical motor is required. High temperature blower motor systems are lubricated at the factory. These motors should require no further lubrication; however, at higher inlet temperatures, increased bearing life can be achieved by annually re-lubricating the motors with 10 to 20 drops of Anderol Number 465 high temperature synthetic lubricant. DO NOT USE petroleum-based oil, as premature bearing failure will result.

## **ROOM AIR BLOWER TESTING**

Several steps are required to verify the correct operation of a blower system associated with Country Flame catalytic stoves. Several additional components have been provided in the blower system to assist the homeowner in testing a catalytic stove blower system. The following general information is provided as steps to be followed in testing a blower system. Refer to the schematics provided with this manual for more detailed information. If problems occur, contact a local Country Flame dealer, Country Flame, or a certified electrician to determine the cause of the problem.

1. Check the automatic fan switch thermal snap disc. Ensure this switch has not been broken during shipment. Check its electrical connections for any loose connections or shorts.
2. Use a hair dryer to heat the thermal snap disk to approximately 110°F. When a click is heard, that means the snap disk has closed and the blower system should begin to operate. **WARNING: 120 Volts AC is available at the snap disk terminals. Caution should be used and if unfamiliar or unqualified to deal with household voltages and currents contact a qualified electrician.**
3. If the blower system fails to operate after completing step 2, remove the power cord from the wall and then bypass the automatic snap disk (fan switch). This can be done by providing a jumper to the wires on each side of the snap disk. Again, if unqualified, contact an electrician. Ensure that the fan switch is not in the off position. Reinstall the power cord in the wall outlet and if the blower system begins to operate, replace the defective automatic fan switch and wire it correctly.
4. If the blower system still does not operate, unplug the power cord and rheostat fan switch. Once bypassed, reinstall the power cord into the wall socket. If the blower system begins to operate when power is restored, replace the rheostat switch and restore the connection to the automatic fan switch described in Step 3.
5. If the blower system is still not operative, contact a local Country Flame dealer, Country Flame or a qualified electrician.
6. The O2 model is equipped with two standard blowers located on the left and right of the stove.

## **BLOWER MALFUNCTION**

In the event of any malfunction in the electrical system of your insert/stove, please refer to previous section, electrical system checklist, and blower schematics for wiring details.

## **NO ELECTRICITY**

In the event of a power failure, the catalytic stove will continue to generate heat into the home. This is because the catalytic stove will pull cold air into the bottom of the stove and heat it up. As the air is heated, it rises and pulls itself through the stove and into the room. This is called gravity airflow or convection heat.

## **CREOSOTE BUILDUP**

When wood burns slowly, it produces tar and other organic vapors, which combine with expelled moisture to form creosote. These creosote vapors condense in the relatively cool chimney flue of a newly started fire or from a slow burning fire. As a result, creosote residue accumulates on the flue lining and tends to build up from the top of the chimney or chimney liner towards the bottom of the chimney. If ignited, creosote or creosote tar can make an extremely hot fire, which may damage the chimney or even destroy the house.

The chimney system should be inspected at least twice monthly during the heating season to ensure no creosote buildup is occurring. If creosote has accumulated, it should be removed to reduce the risk of a chimney fire. Inspection should start at the stove connection and work towards the top of the chimney. Again, cooler surfaces tend to build up creosote deposits quicker, so it is important to check the chimney from the top as well as from the bottom. Creosote can be removed with a proper chimney brush. A certified chimney sweep can perform this service at a very reasonable cost. Country Flame strongly recommends that a certified chimney sweep inspect the chimney system at least once before each heating season. Cleaning and repair should be completed as required.

## **FIREBOX TIPS AND TECHNIQUES**

Refer to the WOOD FUEL REQUIREMENTS section in this manual. Below are some tips that Country Flame recommends a homeowner review if heating with wood:

1. Maintaining a home at a comfortable heat for extended periods is a learned talent that requires time and experience. The exact technique will vary with the layout of the home, the location of the stove, the airflow throughout the home, the chimney system, and the wood fuel used.
2. The timing of when wood is added to a fire greatly influences how long a fire will last. A full charge of wood added to a good set of embers will burn several hours and produce heat that is ideal for overnight burns. The same charge of wood when added to a very hot fire produces more intense heat for a shorter period.
3. Adding a large charge of wood to a fire will immediately cool the fire. Naturally, the stove's heat output will be drastically reduced for some period. Adding smaller charges of wood will produce faster starting and more even heating.
4. Ashes in a Country Flame stove insulates the hot coals and makes them last longer. Remember that failure to clean a stove regularly will allow too much ash to build up. This buildup of ash effectively reduces the size of the firebox and lowers the overall heat output. **ASH IS AN INSULATOR!**
5. Ashes must be removed and stored in a fireproof metal container with a tight fitting lid. The container should be kept on a noncombustible floor or on the ground, well away from all combustible materials, until all cinders have thoroughly cooled. An accumulation of too much ash restricts airflow and reduces the available burning area. A layer of an inch or two of ash in the bottom of the stove should be maintained to assist in the fire burn to support combustion and insulate the bottom of the firebox.

## APPENDIX C: CATALYTIC SYSTEM

### THE CATALYTIC COMBUSTOR

Catalytic combustors are designed to withstand 12,000 hours of continuous use or approximately five to six years of operation; however, the life expectancy of any combustor is affected by many variables that can diminish this life expectancy. There are many signs that the combustor is becoming a problem, these include:

- a) Increased smoke from the chimney
- b) Creosote buildup
- c) Sluggish performance
- d) Excessive smoking
- e) Increased fuel consumption
- f) Decreased burn times.

Proper and regular maintenance will not only increase the effectiveness of the combustor, it will also ensure problems are spotted before expensive replacement of the combustor is required. Keeping the combustor cells clear increases the amount of surface area available to promote the catalytic reaction. This will prevent sluggish operation and improved heat output. A combustor may become clogged three ways: a) with fly ash, or b) from creosote, or c) from soot.

1. Fly ash is the normal accumulation of light grey ash. This ash comes from normal combustion and from combustion particles being blown about by normal chimney draft. Gently brushing the combustor with a clean soft brush or lightly vacuuming the combustor will remove fly ash. **DO NOT** use high-pressure air to clean the fly ash as this air can damage the combustor cells. Using cotton swabs to clean ash out of a specific cell is permissible. Care should be taken not to damage the cell.
2. Creosote is a brown tar-like substance that is a byproduct of incomplete combustion. The more creosote, the more this is an indication that the stove is not burning efficiently and is burning at too low a temperature. Creosote must be burned off the combustor. To burn the combustor clean, reinstall it back in the stove and operate the stove at a higher temperature burn for about 30 minutes with the combustor engaged. Repeat this step as necessary until the combustor is clean. **REMEMBER:** if the combustor is covered in creosote, it is likely the chimney and associated pipe are also covered in creosote. Be sure to have the chimney system cleaned. **FAILURE** to clean the chimney can lead to a chimney fire. Ensure the combustor has completely cooled before attempting to remove it.
3. Soot is the dark granular material that can result from burning off the creosote or from burning foreign material in the stove. Clean soot out of the system the same way that fly ash is cleaned from the combustor.
4. A combustor has active elements on the honeycomb material. Without this material, the combustor becomes inactive and the combustor will allow an ever-increasing percentage of particulates to escape up the chimney. An inactive combustor will reduce a catalytic stove's heat output and cause the chimney system to build up creosote. If any large portion of the combustor becomes inactive, the entire combustor should be replaced. Do not operate the stove when it is observed that a large portion of the combustor has become inactive. If the homeowner is not sure about the quality of the combustor, contact Country Flame or one of its local dealers to have the combustor inspected. It is illegal to operate a catalytic stove without a properly functioning combustor.

### CATALYTIC COMBUSTOR CLEANING

Refer to the section on removal of the catalytic combustor and then follow the following instructions.

- Enough distilled water will be required to cover the entire catalytic combustor to a depth of ½" over its total thickness at least three separate times. Do not use tap water as it contains minerals that may adversely effect the designed operation of the combustor. Expect to use at least 3 gallons of distilled water
- White vinegar will also be required, as it will be mixed with the water to form a 50/50 solution that the combustor will be soaked in. Expect to use at least 3 quarts of white vinegar.
- Both the distilled water and white vinegar will be required to be heated so ensure that an old pot is available to heat the solution.
- A large metal wash pan will be required to soak the combustor in after the solution is heated. This wash pan must be large enough to allow the combustor to be completely submerged in the distilled water/vinegar solution.
- A plastic coated wire or heavy cord will be required.

- A number of common hand tools will also be required, such as, soft bristle brush, screwdriver, pliers, and any other tools required to remove the combustor from the stove.
- A home vacuum cleaner with a standard size hose.

Using a clean unused paintbrush and the vacuum cleaner remove any fly ash and loose soot from the combustor. If any combustor cells are totally blocked, use cotton swabs or pipe cleaners to open up the clogged cells. Be careful as too much pressure can damage the wall thereby rendering that combustor cell useless.

Bring the solution to boil. Reduce the heat and slowly dip the combustor into the boiling solution using the cord or coated wire as a handle. Be careful, as any splash can burn. There is no need to keep the solution boiling once the combustor is in place. Do not bang the combustor against the walls or bottom of the pot. Now slowly raise and lower the combustor in the solution to assist in the cleaning process. The combustor should be soaked in the hot cleaning solution for a minimum of 45 minutes.

Once the hot wash is complete, dry the combustor with a soft cotton clean rag. Empty the pot of hot solution in an appropriate drain. Now refill the pot with distilled water and bring it to boil in order to rinse the combustor. Once boiling, use the cord or coated wire to lower the combustor into the hot clean rinse. Reduce heat to a simmer and soak the combustor for about 20 minutes. This rinse cycle should be repeated two to three times with clean distilled water each time.

Ensure that the combustor cells are void of water and ensure complete dryness. Once drying is complete, reinstall the combustor back into the Country Flame stove by reversing the removal instructions. Ensure any worn parts are replaced during this process.

The homeowner should be confident that the combustor is completely dry before reigniting the stove. Any steam that is generated from the combustor will cause damage to the catalytic material. To ensure complete dryness of the combustor, it can be placed in the family oven for one to two hours at 350°F. Allow the combustor to cool before reinstalling it in the wood stove.

## **REPLACING THE COMBUSTOR**

Any time a firebox is worked on, the combustor should be inspected to determine if cleaning is required or damage demands replacement. Inspect the combustor for deterioration. If damage is found, replace the entire combustor and any worn parts used for installation. Common damage that might be encountered in a combustor is:

### **PEELING**

Peeling occurs when the beige metal coating or catalyst material is peeling off the ceramic base. If large areas peel, this can render the combustor useless, so be prepared to replace it if necessary.

### **CRACKING**

If random lines of cracking are observed in the ceramic base, replace it, especially if large pieces are missing or falling out.

### **CRUMBLING**

This is different from cracking as crumbling is caused by thermal shock. Crumbling occurs if the stainless steel shield deteriorates and the flames make direct contact the combustor. Overheating and then cooling the combustor too quickly will also cause the substrate to crumble.

### **MECHANICAL CRACKING**

If the combustor receives a hard bump or is dropped, then mechanical cracking or fracture will occur. Mechanical cracks usually follow a structural line in the ceramic wall. The breakage will not be as random as thermal cracking. Mechanical cracking does not affect the combustor performance as long as all parts of the combustor are in place.

Always replace a catalytic combustor with the same combustor as recommend by Country Flame. If a different combustor is used, performance of the stove could be adversely affected.

## **WARRANTY**

Catalytic stoves are designed to operate at high temperatures only with the combustor engaged. Removing the combustor will allow uncontrolled fires that will eventually damage the stove. Removing the combustor and operating a catalytic stove voids the warranty.

## **HOME INSURANCE**

Improper operation of a woodstove can affect homeowner insurance coverage. Always follow manufacturers recommended instructions when operating any woodstove.

## **FEDERAL LAW**

Federal and many state laws require that all catalytic woodstoves be maintained and operated with combustors to reduce pollution over the entire life of the stove.

## **COMBUSTOR PROBLEMS**

The following questions are provided to help determine if the catalytic combustor is working. If the answer to these questions is YES, then the combustor is usually working as it was designed:

1. Is the stove producing the same amount of heat for the same wood consumption?
2. Does the catalyst glow red for a short amount of time during the burning of the wood load? By looking inside the stove, directly over the damper rod, the combustor can be seen.
3. Is creosote buildup in the chimney the same as when the combustor was new?
4. Is white smoke seen exiting the chimney?
5. Does a visual inspection of the catalyst show it to be clean of any fly ash, creosote or soot?
6. Is there a color variation in the honeycomb material signifying inactive portions of the combustor?

If the answer to any of the above questions is NO, then look to the Trouble Shooting Guide to determine if the catalyst must be replaced.

NOTE: KEEP AND REFER TO THE CATALYTIC COMBUSTOR INSTRUCTIONS AND WARRANTY INFORMATION. IN THE EVENT INFORMATION IS REQUIRED ABOUT THE CATALYTIC COMBUSTORS THAT COUNTRY FLAME INSTALLS IN ITS STOVES, CONTACT [WWW.APPLIEDCERAMICS.COM](http://WWW.APPLIEDCERAMICS.COM) FOR ADDITIONAL INFORMATION ON A SPECIFIC CATALYST.

## **MODEL O2 CATALYST INSPECTION & REPLACEMENT**

**CAUTION:** Be certain that there is no fire in your Country Flame stove and that the unit has had sufficient time to cool.

### **CLEANING INSPECTION**

To inspect the catalyst, look up inside the stove and locate the catalytic combustor stainless steel plate. Remove the four bolts that allow the stainless steel plate to be removed. Inspect for a dirty or plugged combustor. If dirty, refer to the cleaning information provided earlier in this section. Proceed to remove the combustor for cleaning. Once the catalyst is cleaned, replace the cleaned catalytic system back into the stove.

### **REPLACEMENT INSPECTION**

Visually inspect the catalytic combustor at least 3 times during the heating season to determine if physical deterioration has occurred. Only replace the combustor if it has become damaged. Cleaning can improve catalytic combustor performance so before throwing it away, always attempt to clean it before disposing of a non-functioning combustor. Refer to the cleaning process defined earlier in this section. Replace the catalytic combustor with a complete kit by contacting Country Flame or one of its local authorized dealers.

### **REPLACEMENT**

Make sure your kit is complete and all parts are available for installation. Refer to FIGURE 20 to aid in the disassembly and reassembly process. To remove the catalyst system, remove the eight nuts and eight washers along with the stainless steel plate. The catalyst system will drop down so ensure that no mechanical damage occurs during the removal process. Be prepared to handle the weight and ensure no damage occurs to the catalyst from mechanical shock.

To install a new catalytic system, assemble the catalyst and gaskets, if required, in the catalytic holder. Align this system with the carriage bolts (4). Place four washers and then four nuts on the carriage bolts. Tighten with a wrench. Now install the stainless steel shield and install four washers and then finger tighten the four nuts. There should be approximately 5/8" thread exposed on each carriage bolt. Ensure the stainless steel plate is placed with the bent part up and to the front of the stove. The catalyst holder has a stop on the bottom of the part. This stop ensures the stainless steel shield cannot be drawn up too close to the holder and interfere with proper airflow.

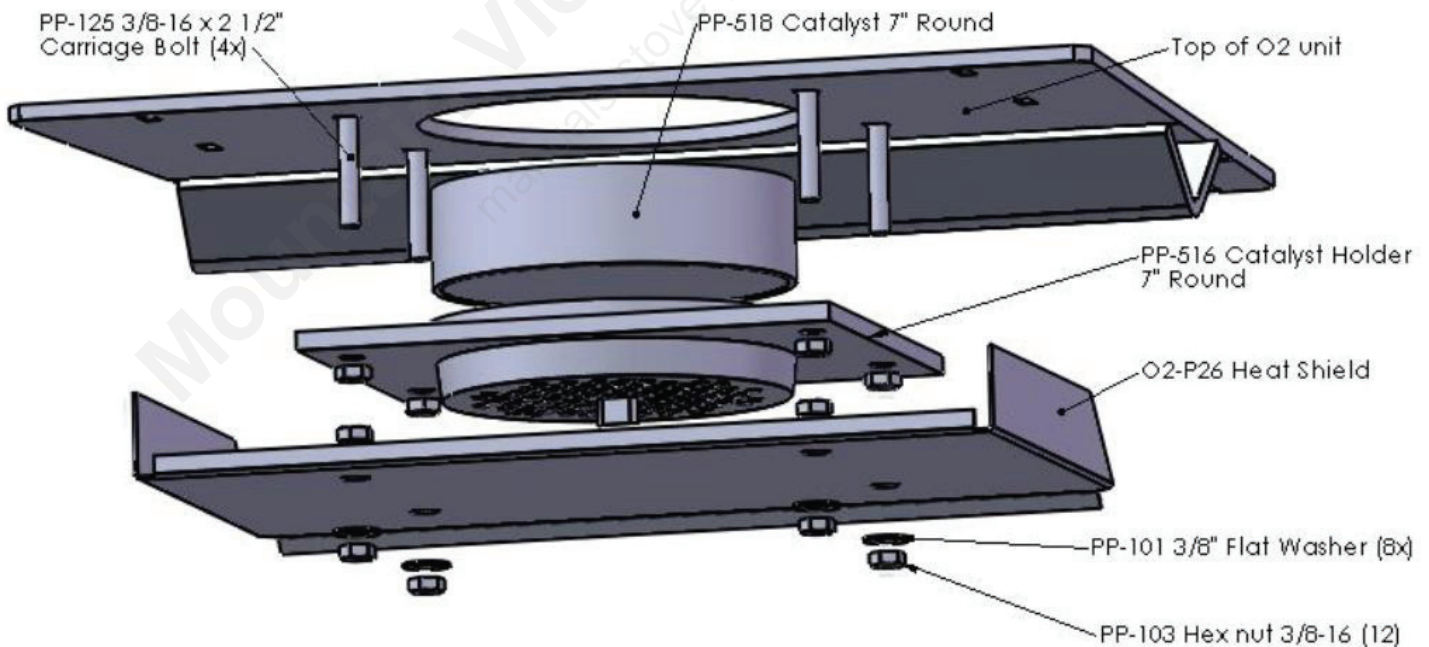

FIGURE 20: CATALYTIC SYSTEM FOR MODEL O2 STOVE

## **APPENDIX D: BLOWER SYSTEMS, ELECTRICAL**

## BLOWER THEORY OF OPERATION

All Country Flame catalytic stoves come standard or have optional room air blower systems available. These room air blower systems are designed to pull cool air from the living space into, through, and across the hot catalytic stove body thereby returning the exchanged air to the home at an elevated temperature (heated). These blower systems add to the overall heating efficiency by ensuring that a stove does not rely solely on heat convection to provide warmth to a home. It is important to note that in the event of a power outage, all Country Flame catalytic stoves will continue to operate properly and no damage should occur to the blower system from over heating.

All Country Flame blower systems are designed to turn on and off automatically as the temperatures rise and fall inside the firebox. The blower systems are automated with a thermal 110° F snap disk installed in the blower's electrical system. This thermally activated switch automatically turns the blower on and off. The blower is turned on as the air surrounding the snap disk reaches approximately 110° F. As the air temperature rises, the thermal snap disk closes, completing the electrical circuit thus allowing the fan motor to be activated. Household air is pulled into the stove, heated, and then returned back to the home. In the event the home air temperature drops below approximately 90° F, the switch deactivates, turning off the stove blowers.

The following information and schematics are provided for informational purposes only. A qualified electrician should perform all repairs or installation of the electrical power required for Country Flame stoves.

**WARNING:** Lethal electrical power is present in home electrical circuits. All Country Flame stoves require standard household power at 120 volts, 60 Hz, and 15 amperes. This standard household power should be provided through a National Electric Code approved 3-wire power outlet that is properly grounded. Installing house wiring incorrectly, failing to maintain proper polarity in either the plug or receptacle, or removing the grounding pin can lead to potentially fatal shock hazards. Country Flame strongly recommends the use of a qualified electrician to install, maintain, or service any part of a stove's electrical system.

The schematics provided on the next several pages are for informational purposes. Changes do occur from time to time on stove wiring systems and Country Flame reserves the right to update and change the schematic at its discretion. In the event of any discrepancy between the information provided and the actual wiring of a stove, please contact Country Flame or one of its local dealers.

### MODEL O2

The Model O2 catalytic stove comes standard with a two-blower system. FIGURE 22 shows the electrical schematic of the Model O2 blower system. One blower is mounted on the left side and one blower is mounted on the right side of the stove. Each of these blowers pull room air into a cavity and push it to the back and then into the top cavity of the Model O2 stove. As the air passes around this cavity and comes out the top of the stove, it picks up heat to warm the home. The fans are designed to run continuously once the thermal snap disk closes and completes the electrical circuit.

**BLOWER CARE:** At least once a season (light use) and every six months (heavy use), the fan blades should be removed and cleaned. The motors should receive proper oiling at this time. Cleaning the squirrel cages can be done by brushing or blowing them off. The motors should be lubricated annually with an approved electric motor lubricant. Lubricate with 10 to 20 drops of Anderol Number 465 high temperature synthetic lubricant. DO NOT USE petroleum-based oil, as premature bearing failure will result.

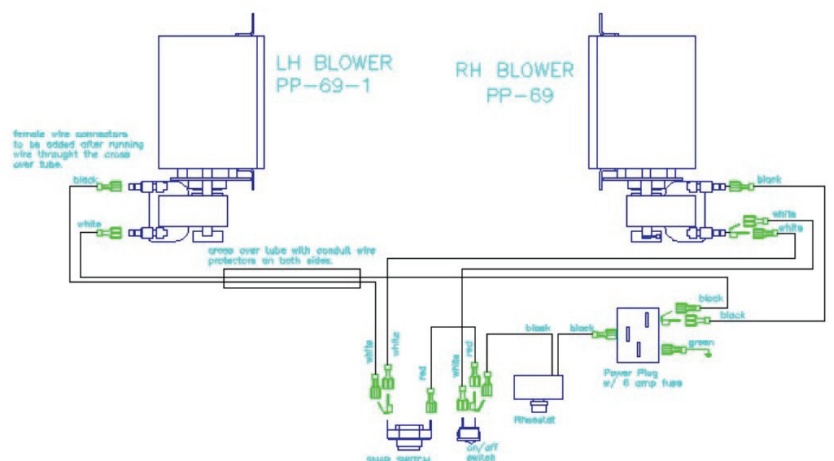

**FIGURE 22: MODEL O2 BLOWER SYSTEM ELECTRICAL DIAGRAM**

## APPENDIX E: WARNING LABELS

# ATTENTION

Before building the first fire, if **GOLD** or **NICKEL DOORS** are installed, be sure the doors are cleaned of all fingerprints. This cleaning can be accomplished by wiping down all plated (gold or nickel) accessories with Windex. **DO NOT** scrub these accessories or damage to plating can occur.

**FAILURE** to clean plated accessories will cause fingerprints or other marks to be permanently burnt into the part.

FIGURE 24: GOLD DOOR WARNING LABEL

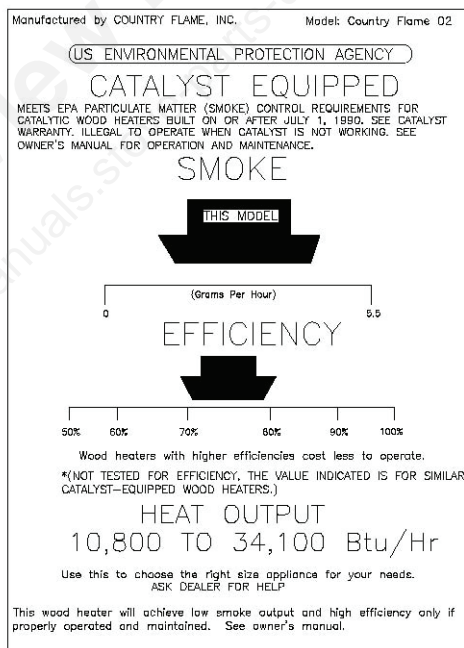
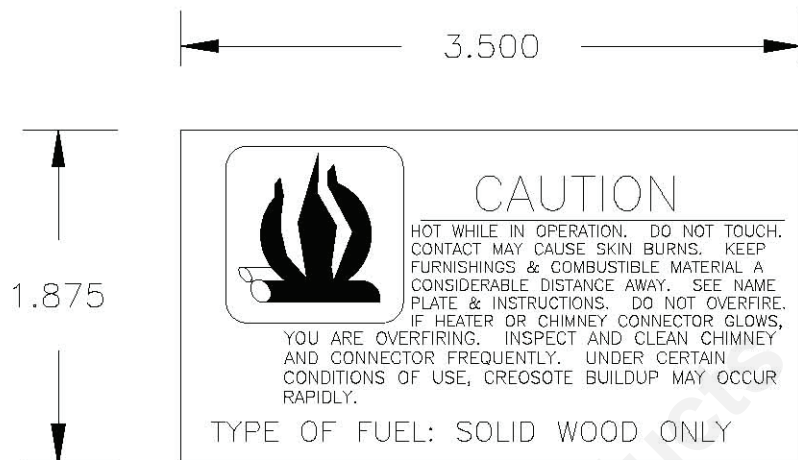

FIGURE 25: EPA STOVE STICKER



**FIGURE 26: WARNING LABEL, PROTECT CHILDREN**



**FIGURE 27: WARNING LABEL PROPER ELECTRICAL GROUND**



**FIGURE 28: WARNING LABEL STOVE BRIGHT PAINT**

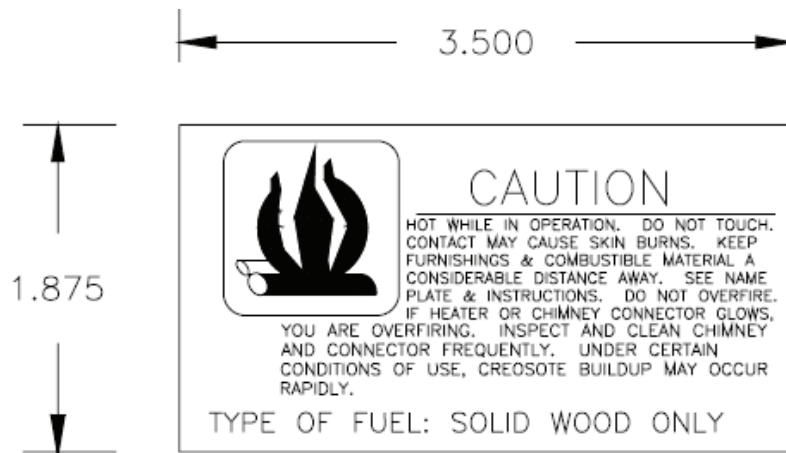

**FIGURE 26: WARNING LABEL, PROTECT CHILDREN**

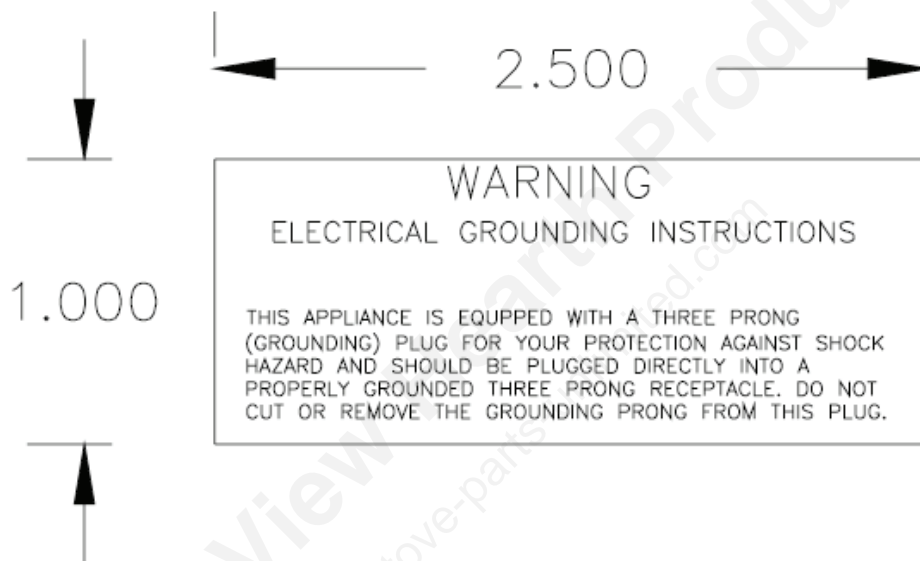

**FIGURE 27: WARNING LABEL PROPER ELECTRICAL GROUND**



**FIGURE 28: WARNING LABEL STOVE BRIGHT PAINT**

## APPENDIX F: TROUBLESHOOTING GUIDE

PROBLEM	CAUSE	SOLUTION
<b>FIREPLACE/STOVE/CHIMNEY SMOKES</b>	Chimney cap restricted	Clean the chimney cap and remove any debris that may have accumulated in the screen.
	Damper not set correct.	Open damper until 700oF achieved, then close damper to activate catalytic combustor.
	Downdraft	Add a chimney cap designed to prevent downdrafts.
	Obstruction	Remove any obstruction at least 10 feet from top of chimney or increase chimney height.
	Atmospheric conditions	Atmospheric conditions may cause smoke if the chimney pipe is not straight, has too many elbows, or is leaking. Consult with professional.
	Chimney obstruction	Check the flue system for obstructions and clean as needed.
	Too many flues to a chimney	Consult Certified Chimney Expert.
	House too tight	Crack window by stove, close upper floor windows or provide combustion air to stove.
	Paint curing	Country Flame cures all new stoves at plant so this should not last more than 10 to 15 minutes.
	Leaky chimney	Chimney joint leaks or mortar leaks cause chimney draft to be weak. Consult with professional.
<b>GLASS GETS DIRTY</b>	Wet wood	Dry wood produces much less creosote than wet wood.
	Normal buildup	A damp cloth dipped in wood ashes used to wipe glass clean. Household glass cleaners are not effective in cleaning glass. <b>DO NOT USE</b> abrasives, as permanent glass damage will occur. Use fireplace glass cleaners, like Stove Bright.
	Position of fire	Hot fires help keep glass clean. Burning logs, close to the glass, will tend to dirty the glass.
<b>HEAT OUTPUT POOR</b>	Wet wood	Dry wood can produces at least twice the BTU's. Use properly seasoned hardwoods.
	Load Fire Differently or Increase Amount of Wood	Wood loaded front to back may improve performance versus loaded side to side. Alternatively, increase the load of wood but when starting a fire allow it to burn rapidly for several minutes to establish good burn. A well-built fire is much more efficient and heats better than a few sticks.
	Too high a speed on blower	Always adjust the speed of the blower to the size of the fire. If air moves to quickly across small fire, little heat will be transferred.
<b>HEAT OUTPUT POOR (Continued)</b>	Severely cold weather	Depending on house insulation package, ceiling height, stove insulation (leaking insert) or air infiltration, fuel consumption may increase.
	Overdraft	Control with stove combustion air damper or chimney damper to reduce excessive draft. Consult with professional.
	Draft controls not adjusted	Combustion is restricted when the air is restricted. Adjust combustion air properly for fire size and burn rate.
	Bad wood	Hardwood has higher Btu rating than softwood. Dry rotted wood has low Btu and lots of ash.

<b>PROBLEM</b>	<b>CAUSE</b>	<b>SOLUTION</b>
<b>BLOWER DOES NOT WORK</b>	Thermal Snap Disk	Blower system cannot operate until snap disk closes electrical circuit. Consult with professional.
	Wiring	Loose connection or damaged (pinched or cut) wire. Carefully check wiring upon removal and reinstallation. Consult with professional.
	Electric Motor	Motor may be worn out or bearings froze up from years of use. If oil is required, make sure it is done annually. Consult with professional.
	House Power Outlet	Consult with professional. DO NOT use extension cord to operate stove. Ensure power outlet has proper polarities for all prongs.
<b>LARGE AMOUNTS OF CREOSOTE</b>	Poor Quality Fuel	Unseasoned or poor quality wood fuel.
	Combustion Air	Too little combustion air will choke fire and cause poor burn. Hotter fires produce less creosote.
	Flue size	The larger the flue, the harder to heat, the cooler it operates, creating more creosote.
	Geography	Outside flues, north side of house, normal wind currents cooling chimney thus poor draft. Design and location of chimney is critical to operation.
	Humidifier	Heavy moisture in combustion air will cool exhaust gases and cause more creosote. If humidifier is used, measure home humidity.
<b>GOLD/NICKEL DOOR DAMAGE</b>	Cleaning	Plated doors should be cleaned BEFORE FIRST FIRE to ensure no permanent damage occurs.
	Abrasives	Do not use abrasives, chemicals, or unknown compounds on plated doors. Permanent damage will occur. Refer to cleaning instructions in this manual.
<b>WALLS GETTING TOO HOT</b>	Clearances	Insert stoves must maintain minimum clearances. Consult with professional but if walls get hot --- DO NOT BURN FIRE as combustibles may self ignite into house fire.
	Improper Installation	If proper clearances are maintained walls should not get hot. If they are, assume improper installation, leaky chimney, or some other problem. Consult with professional.
	Defective Stove	If stove firebox does not remain sealed, hot gases can escape and overheat surrounding area. Inspect monthly during heavy use and annually by professional.
<b>CREOSOTE/FIRE ODOR</b>	Creosote	Firebox is dirty. Creosote will give off odor. Make sure firebox stays clean through "hot safe fire."
	Chimney	If stove is not operating, chimney may be prone to downdraft bringing in odor. Close all air controls to minimize downdraft.
	Catalytic Combustor	Wore out or nearing end of life causing stove to burn dirty. Consider new catalyst.
<b>ANNUAL MAINTENANCE</b>	Inspection	Have Country Flame local dealer or certified chimney sweeps annually inspect and approve stove system. If there are warranty issues, contact Country Flame with Model & Serial Number.

## APPENDIX G: CHIMNEY & VENTING GUIDE

### VENTING SYSTEMS

National Building Codes require venting of systems that burn solid and liquid fuels. Approval and listing agencies define venting as the means for removing the flue gases from a facility's equipment that burns solid or liquid fuels to the outside atmosphere. Further, these agencies state that venting systems shall be engineered and constructed in order to ensure a positive flow of air adequate to remove the flue gases to the outside atmosphere. Venting and the requirements associated with venting thereby define the chimney systems that are ultimately designed for each solid fuel-burning stove or fireplace.

There are only two methods (with many variations) to build proper venting systems for solid fuel (wood burning) systems: a) prefabricated chimney systems as shown in FIGURE 29 or b) masonry chimney systems as shown in FIGURE 30.

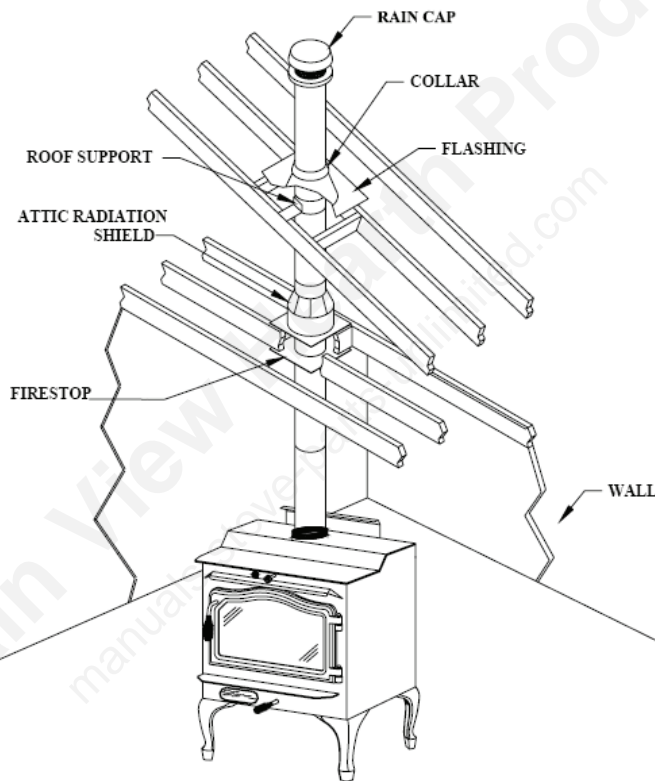

**FIGURE 29: FREESTANDING PREFABRICATED CHIMNEY SYSTEM (no chase)**

Whichever system the homeowner chooses to have installed, chimney systems are expensive. These parts of a heating system are effective at removing exhaust gases for decades or they repeatedly fail at their function, cause problems, and create expense. Cut corners on installation or scrimp on costs and the chimney system will become a source of nightmares. In the chimney business, no matter how expensive it is to do it right the first time, it is far less expensive than doing it over. Almost 30 years of manufacturing experiences has taught Country Flame that if there is one-place customers must be vigilant and become knowledgeable, it is in ensuring a chimney system is properly engineered, designed and installed to match the heating stove being installed in their home.

If there is any doubt, hire a third party inspector to verify the installer's work when complete. To avoid, costly mistakes or repairs, ask questions and verify the installation work. If there is still any doubt, contact Country Flame or a local authorized dealer to obtain the name of "industry experts" who can provide the correct answer.

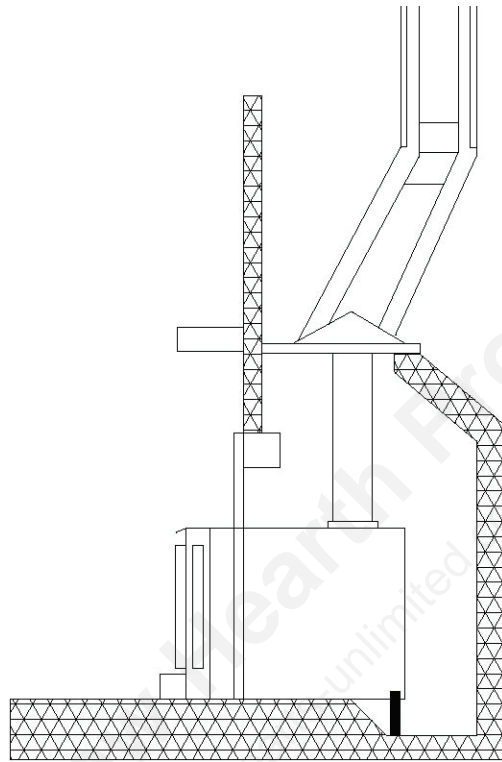

**FIGURE 30: INSERT MASONRY CHIMNEY SYSTEM**

When modifying, fixing, or installing a brand new chimney system, it is important to obtain knowledgeable help from a certified professional. The homeowner should select an experienced professional. This is necessary because each home, each location, each chimney system has unique requirements and variables. The more experience a chimney professional has, the more likely the results will please the homeowner for years to come.

### **THIMBLE INSTALLATION**

Catalytic stove installations that require a connection from the stove through a combustible wall to a masonry or prefabricated chimney require either a UL Listed thimble (wall penetration assemblies) or the methods outlined in the National Fire Association Standard 211, which is outlined below. It is important that the homeowner or installer be well versed in these variations and understands which one is best suited for their application. The following diagrams provide examples and explanations of chimney connector systems and clearances from combustible walls for residential heating appliances. During any installation, it is important to consult with the local code authority or an installation professional to ensure your installation is properly done. The following additional requirements will apply to FIGURE 31 through FIGURE 34:

- 1 Insulation material used as part of a thimble wall pass-through system shall be constructed of noncombustible material and shall have a thermal conductivity of  $1.0 \text{ Btu-in/hr-ft}^2 \text{ - } ^\circ\text{F}$  ( $4.88 \text{ kg cal/hr-m}^2 \text{ - } ^\circ\text{C}$ ) or less.
- 2 All clearances and thicknesses are minimums; larger clearances and thicknesses shall be permitted.
- 3 Any material used to close up an opening for the connector shall be of noncombustible material.
- 4 A connector to a masonry chimney, except for the installation shown in FIGURE 31, shall extend in one continuous piece through the wall pass-through system and the chimney wall to the inner face of the flue liner, but not beyond.

**NOTES**

1. Minimum chimney clearance from masonry to brick, sheet steel supports, and combustibles 2 in.
2. Masonry chimneys constructed to NFPA 211.

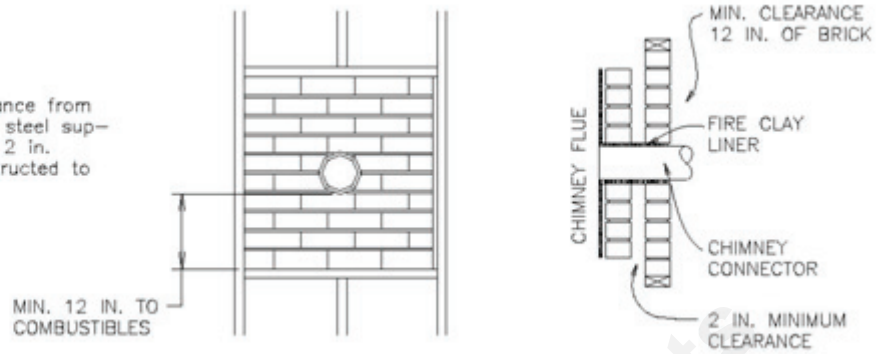
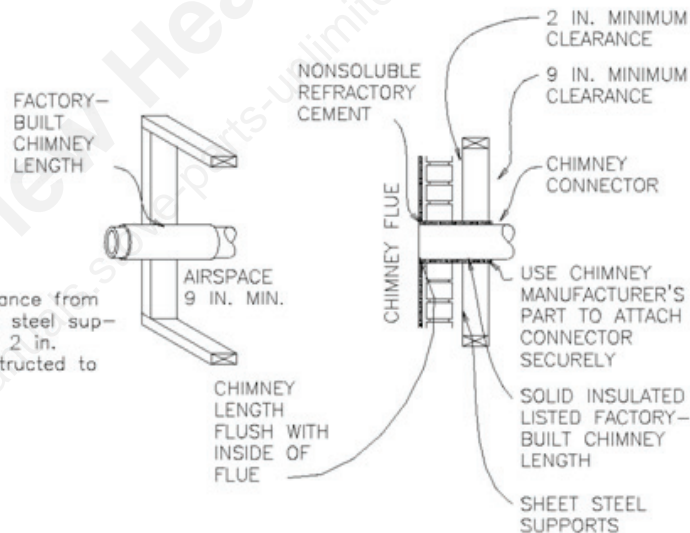

**FIGURE 31: MASONRY CHIMNEY TO COMBUSTIBLE WALL**

A minimum of three and one-half inch thick brick masonry chimney framed into a combustible wall with a minimum of twelve-inch brick separation from the clay liner to combustibles is permissible. The clay liner (stove) shall run from the outer surface of the brick wall, but not beyond the inner surface of chimney flue liner. The clay liner should be firmly located and firmly cemented in its proper location.

**NOTES**

1. Minimum chimney clearance from masonry to brick, sheet steel supports, and combustibles 2 in.
2. Masonry chimneys constructed to NFPA 211.

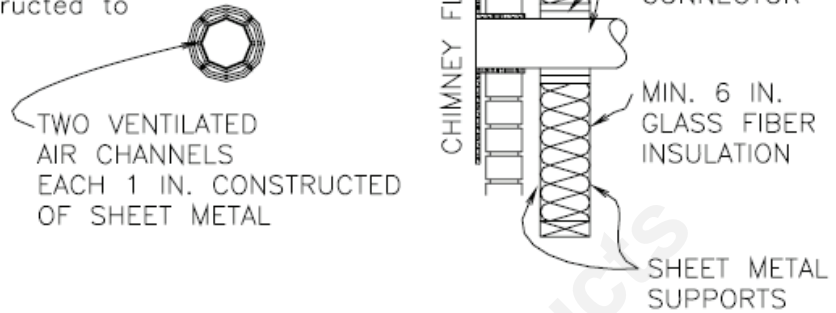

**FIGURE 32: TYPE HT 2100<sup>0</sup> FACTORY-BUILT CHIMNEY**

Type HT 2100<sup>0</sup> factory-built chimney length that has the same inside diameter as the chimney connector. The factory-built chimney must also have one inch or more insulation with a minimum of nine inches of airspace between the outer wall of the chimney length and any combustibles.

**NOTES**

1. Minimum chimney clearance from masonry to brick, sheet steel supports, and combustibles 2 in.
2. Masonry chimneys constructed to NFPA 211.

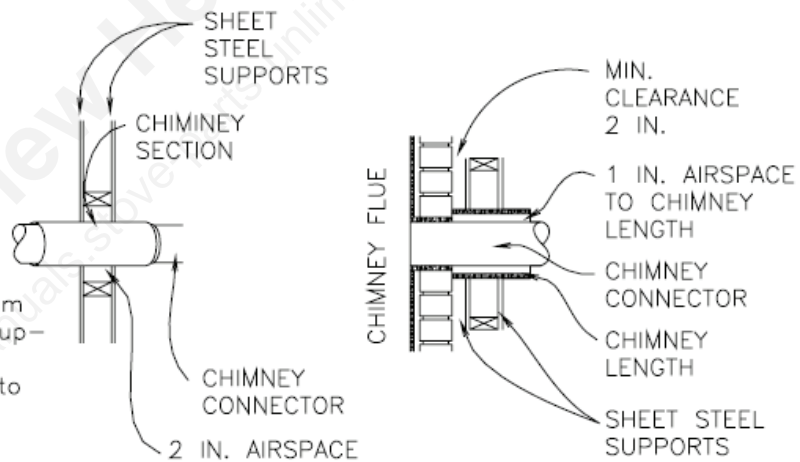

**FIGURE 33: SHEET STEEL CHIMNEY CONNECTOR, VENTILATED THIMBLE**

Sheet steel chimney connectors must be made from material that is a minimum of 24 gauge in thickness and is separated by two, one-inch air channels. The outside of the air channel must be separated from combustible materials by a minimum of six inches of glass fiber insulation. The wall opening shall be covered and the thimble will be supported with sheet steel supports that are made from material at least 24 gauge in thickness.

**NOTES**

1. Minimum chimney clearance from masonry to brick, sheet steel supports, and combustibles 2 in.
2. Masonry chimneys constructed to NFPA 211.



**FIGURE 34: TYPE HT 2100°FACTORY-BUILT CHIMNEY**

Installations that use type HT 2100° listed factory-built chimney require an inside diameter two inches larger than the chimney connector. This listed chimney must have at least one inch or more insulation that serves as a pass-through for a single-wall sheet steel chimney connector that is a minimum 24-gauge thick and with a minimum two-inch air space between the outer wall of chimney section and any combustibles. The minimum length of the chimney section must be twelve inches and that chimney section will be spaced one inch away from the connector using sheet steel support plates at both ends of chimney section. Cover the opening and support the chimney section on both sides with sheet steel brackets that are a minimum of 24-gauge thickness. Securely fasten these brackets to the wall surfaces. Any fasteners used to secure the chimney section shall not penetrate any portion of the chimney flue liner. A minimum of three screws per chimney connector must be used.

A chimney connector shall not pass through an attic, roof space, closet, floor, ceiling, or similar concealed space. Where passage through a wall or partition of combustible construction is desired or necessary, the installation shall conform to NFPA 211 or CAN/CSA-B365 requirements.

Whatever brand of chimney system is purchased for your Ovation installation, you must ensure that all chimney manufacturer's installation instructions are followed and that all national and local codes have been met.

### **OUTSIDE AIR COMBUSTION**

It is imperative that the installer or homeowner ensures that a minimum of at least eight square inches (fifty square centimeters) of outside air be admitted to the hearth room or directly to the stove. If installation allows, a four-inch diameter pipe can be brought in through an exterior wall and connected, using the optional fresh air adapter, directly to a catalytic stove.

Provision for outside combustion air may be necessary to ensure that fuel-burning appliances do not discharge products of combustion into the house. Guidelines to determine the need for additional combustion air may not be adequate for every situation. If in doubt, it is advisable to provide outside air.

Outside combustion air may be required if:

- 1 A catalytic stove does not draw steadily, smoke rollout occurs; fuel burns poorly, or back-drafts occur whether or not combustion is present, or
- 2 Existing fuel-fired equipment in the house, such as fireplaces or other heating appliances smell, do not operate properly, suffer smoke rollout when opened, or back-draft occurs whether or not combustion is present, or
- 3 The home is equipped with a well-sealed vapor barrier and tight fitting windows or has any powered devices that exhaust house air, or
- 4 There is excessive condensation on home windows in the winter, or
- 5 A ventilation system is installed in the house.

If any of these or other indicators suggests that infiltration air is inadequate to sustain proper combustion in a catalytic stove, additional combustion air should be provided from the outdoors. Outside combustion air can be provided to the appliance by the following means:

**Direct connection:** appliances can only use direct connection of outside combustion air if they are certified for this type installation. Follow the Ovation instructions for direct connection of outside combustion air.

**Indirect connection:** for appliances not certified for direct connection of outside combustion air, outside air can be ducted to within twelve inches of the appliance.

**Mechanical ventilation:** if the house has a ventilation system (air change or heat recovery):

A ventilation system may be able to provide sufficient combustion make-up air for a catalytic stove but the homeowner should be informed that the ventilation system might need to be re-balanced by a ventilation technician after installation of a catalytic stove.

### **CHIMNEY INSTALLATION**

Install an approved chimney system in an interior **chase** of a home. **A chase is defined as an enclosure (combustible or noncombustible) that is built to cover the chimney system.** Interior chimney systems, with a properly constructed chase, provide better overall stove performance. Performance is enhanced because the chase maintains heat around the chimney thereby ensuring improved draft that improves venting (removal of spent exhaust gases.) In areas where temperatures hover or remain below freezing, the use of an exterior chimney will only increase the likelihood of problems. Some of these problems will be difficult starts, weak draft, high rates of creosoting, and increased maintenance of the system. Exterior chimneys are also prone to down drafting and flow reversal. Installations, which are located on lower floors in the house, such as in a basement, in combination with an exterior chimney are especially prone to flow reversal.

Always follow the Chimney Manufacturer's installation procedures over any recommendations this manual provides on chimney systems. Installing the chimney must be in compliance with local codes, chimney manufacturer's recommended procedures, and the chimney must connect to the Country Flame stove in accordance with instructions provided.

**CAUTION: DO NOT FILL REQUIRED CLEARANCES AROUND THE CHIMNEY AND SURROUNDING**

## COMBUSTIBLE MATERIAL WITH INSULATION!

- 1 The Country Flame catalytic stoves covered in this manual use either listed six-inch diameter or listed eight-inch diameter chimney system. Use the correct chimney connectors in the installation of a catalytic stove.
- 2 **IMPORTANT:** All Country Flame catalytic stove's flue collars have been engineered, tested, and approved for a specific stove that takes into account the minimum and maximum burn rates. These flue collars have the correct inside diameter to accept listed standard chimney connectors from a variety of manufacturers. Ensure the chimney connector is properly interfaced, properly sealed, and properly secured according to local and national codes. FIGURE 35 shows the correct and incorrect installation of a chimney connector into a Country Flame catalytic stove. Installed correctly, the first section of chimney connector will support the entire chimney, ensuring no leakage of creosote or fumes.

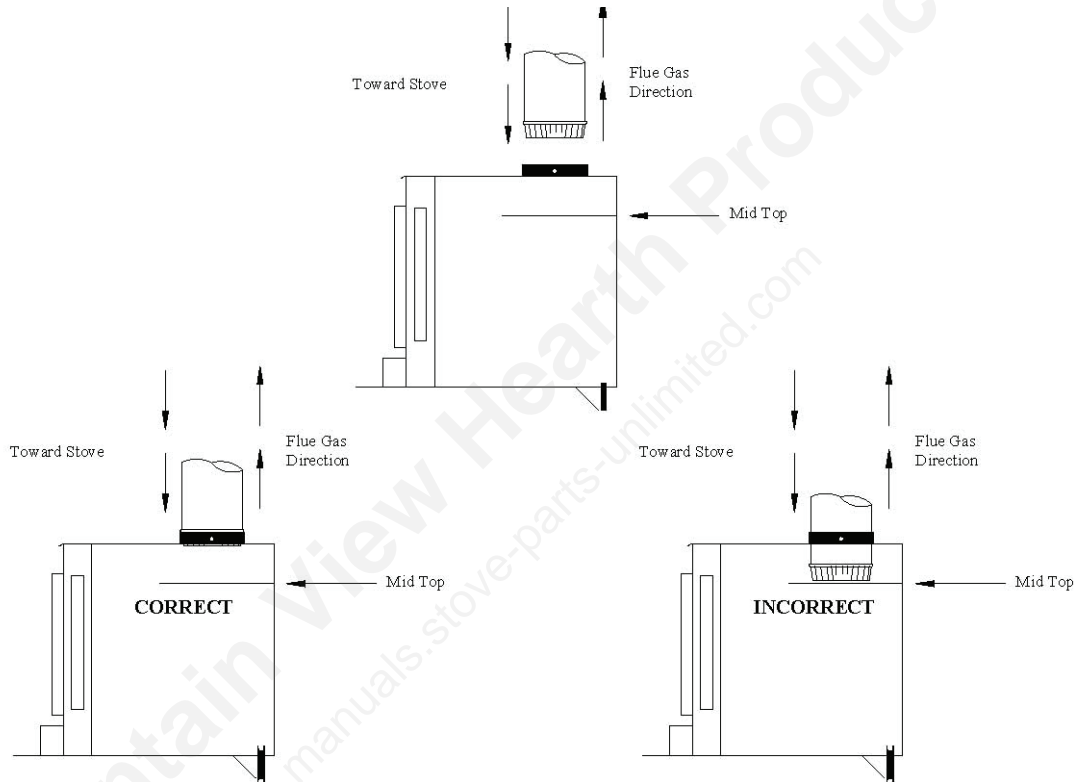

**FIGURE 35: CATALYTIC STOVE TO CHIMNEY CONNECTOR INTERFACE**

- 1 **MINIMUM CHIMNEY HEIGHT:** A chimney must be a minimum of 8' above the top of a catalytic stove. The chimney must extend a minimum of three feet above the highest point where it passes through the roof. National building codes require that all chimneys shall extend at least 3 feet above the point where it passes through the roof. In addition, the chimney must extend at least 2 feet higher than any portion of the building that is within 10 feet of the chimney. FIGURE 36 shows chimney connector roof height requirements.

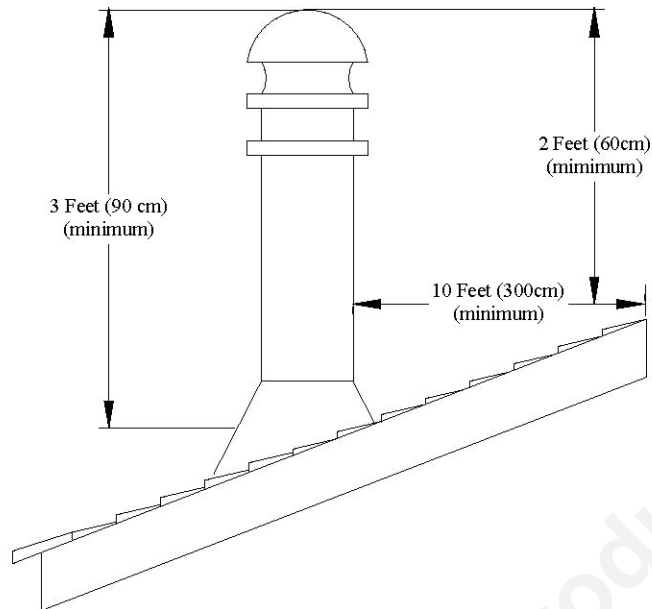

**FIGURE 36: CHIMNEY ROOF CLEARANCES**

2 **MAXIMUM CHIMNEY HEIGHT:** A chimney can be no taller than 50' high as measured from the top of the catalytic stove flue collar. Chimney height is affected by many factors, consult both national and locale codes to ensure proper installation for a specific application.

3 **ELBOWS USED IN CHIMNEY CONSTRUCTION:** A maximum of four thirty-degree elbows can be used in chimney construction as long as they are used in two sets offset from each other. Maximum offset between the sets of elbows is 4'. If two thirty-degree elbows are used, the chimney must be a minimum of 12' high. When four thirty-degree elbows are used, the chimney must be a minimum of 25' high. Follow all chimney manufacturers' clearance recommendations for distances from combustible material and the location of support bracket requirements.

4 A chimney venting a catalytic stove shall not be used to vent any other appliance.

**WARNING:** In cold areas, an air-cooled chimney may generate a large amount of water due to condensation. This water will accumulate on top of the catalytic stove and may cause corrosion. Country Flame Technologies does not warrant any damage nor are they held responsible for condensation/corrosion problems. In cold climates, Country Flame recommends the use of double wall insulated chimney connectors that are UL103 listed and rated to HT 2100°.

5 A rain cap must be installed on top of the chimney. Failure to install a rain cap will cause corrosion of the chimney system and degrade its expected life and warranty.

6 **FOLLOW THE CHIMNEY MANUFACTURER'S INSTALLATION PROCEDURES FOR PROPER CLEARANCES BETWEEN THE CHIMNEY AND ANY COMBUSTIBLE MATERIALS.** Do not fill this space with insulation or any other combustible material.

7 Any portion of the chimney system that extends through a living (accessible) space must be enclosed to avoid contact with combustible materials, damage the chimney, or to prevent occupants from coming in contact with the chimney system.

## PREFABRICATED CHIMNEY SYSTEM INSTALLATION

Cut and frame the required holes in the floors, ceilings, and roof where the chimney will pass through.

**REFER TO THE CHIMNEY MANUFACTURER'S INSTRUCTIONS FOR PROPER CLEARANCES REQUIRED BETWEEN CHIMNEY AND COMBUSTIBLES, REQUIRED SUPPORT BRACKETS, AND THE PROPER FRAMING REQUIRED AROUND THE CHIMNEY SYSTEM COMPONENTS.**

Install chimney sections, fire stops, attic insulation shields, and any other chimney parts per the manufacturer's installation instructions. Install the flashing, storm collar and the chimney cap following the chimney manufacturer's instructions. Refer to the chimney manufacturer's requirements concerning supports, bracing, anchors, and other required material.

FIGURE 37, FIGURE 38, FIGURE 39, Figure 40, FIGURE 41, and FIGURE 42 are provided as examples for different types of chimney system installations. Please consult and utilize a professional installer and follow all chimney manufacturers' instructions during installation of a chimney system.

**FIGURE 37: EXAMPLE CHIMNEY INSTALLATION (Interior Space)**

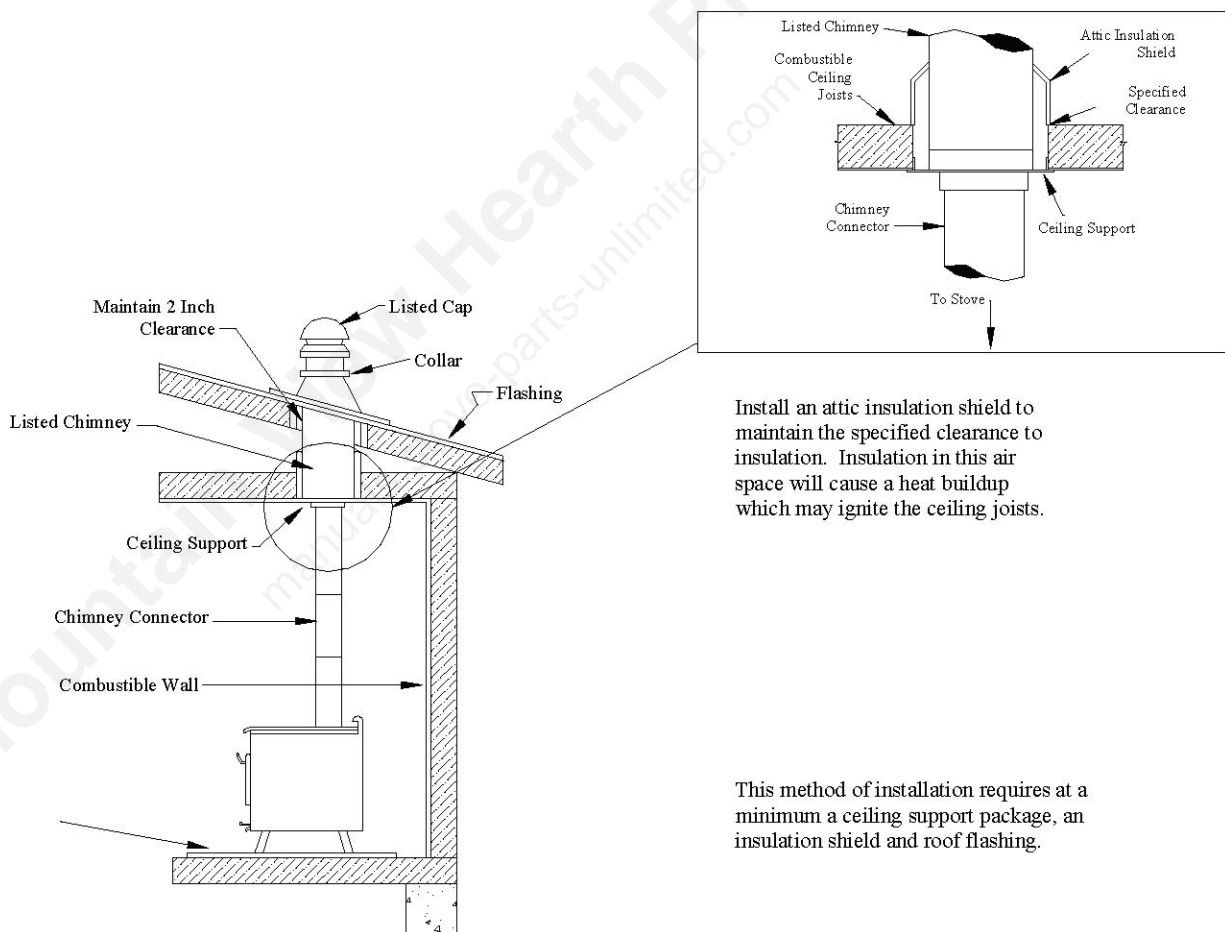

**FIGURE 40: EXTERIOR CHIMNEY SYSTEM**

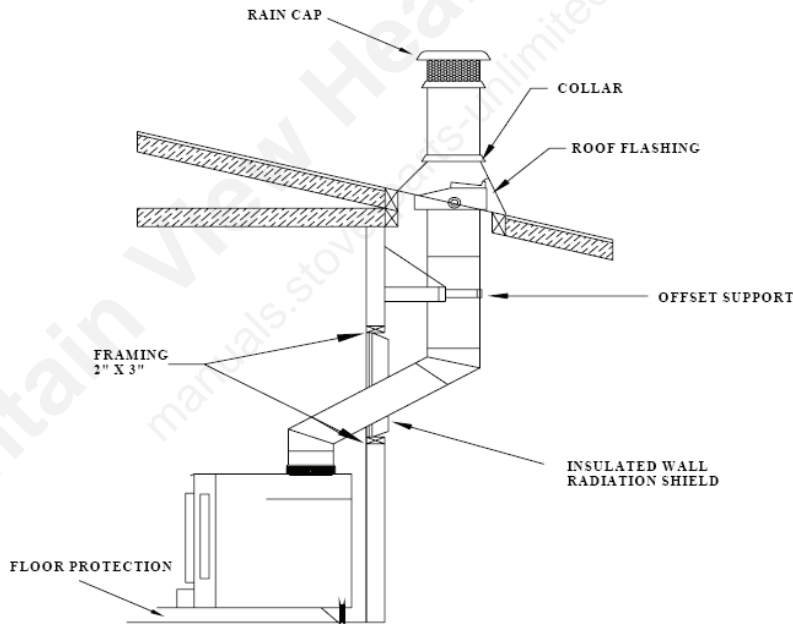
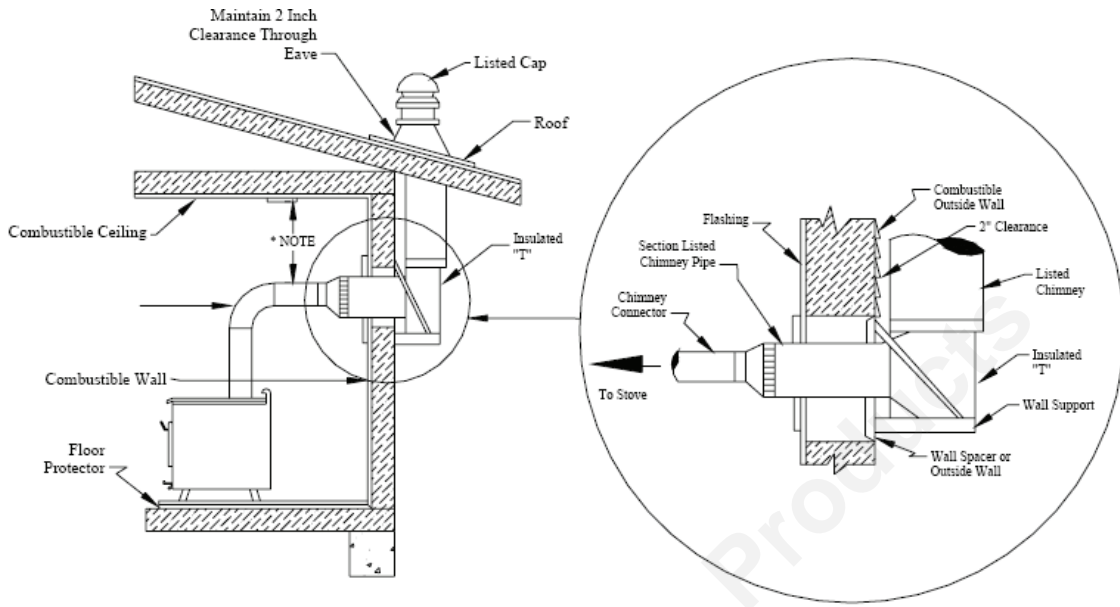

**FIGURE 41: EXTERIOR CHIMNEY SYSTEM**

For the purpose of this manual, a chimney chase is considered a part of the chimney system rather than part of a building. The chimney termination must be placed a minimum of eighteen inches or four hundred and sixty millimeters above the chase.

For installations where more than one chimney is located in the same chase or within the same area, it is recommended that each chimney termination be separated by at least sixteen inches or four hundred and ten millimeters from the next chimney and each chimney termination be placed a minimum of eighteen inches or four hundred and sixty millimeters above the chase. These separations are required to prevent smoke from migrating from one chimney to another. FIGURE 40 shows an example of the required chimney multiple termination dimensions.

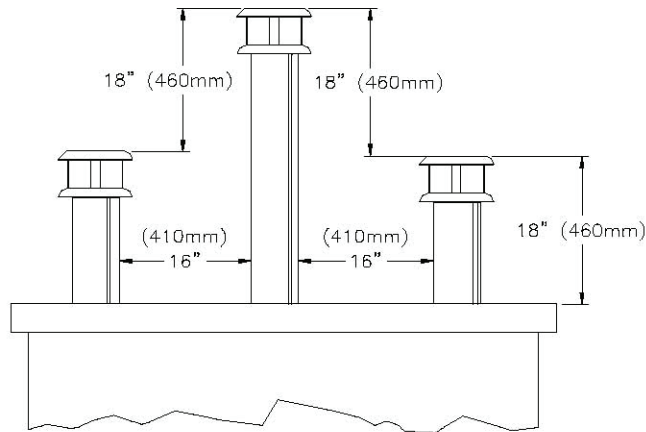

**FIGURE 42: CHIMNEY MULTIPLE TERMINATION REQUIREMENTS**

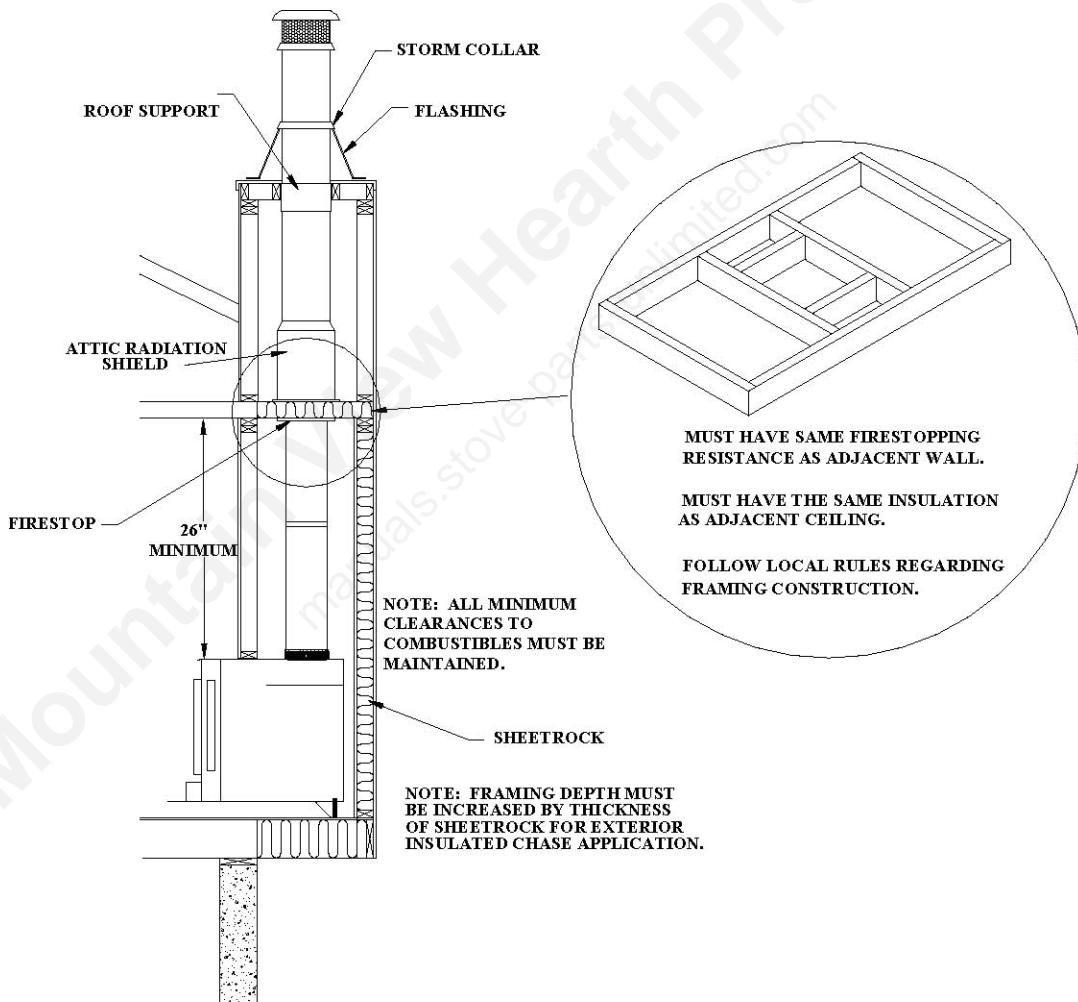

**FIGURE 43: CHIMNEY CHASE, SINGLE EXTERIOR WALL**

FIGURE 43 shows an exterior chase construction for a catalytic stove. For additional information on building a chase or for construction of an interior chase, please consult national and local building codes.