

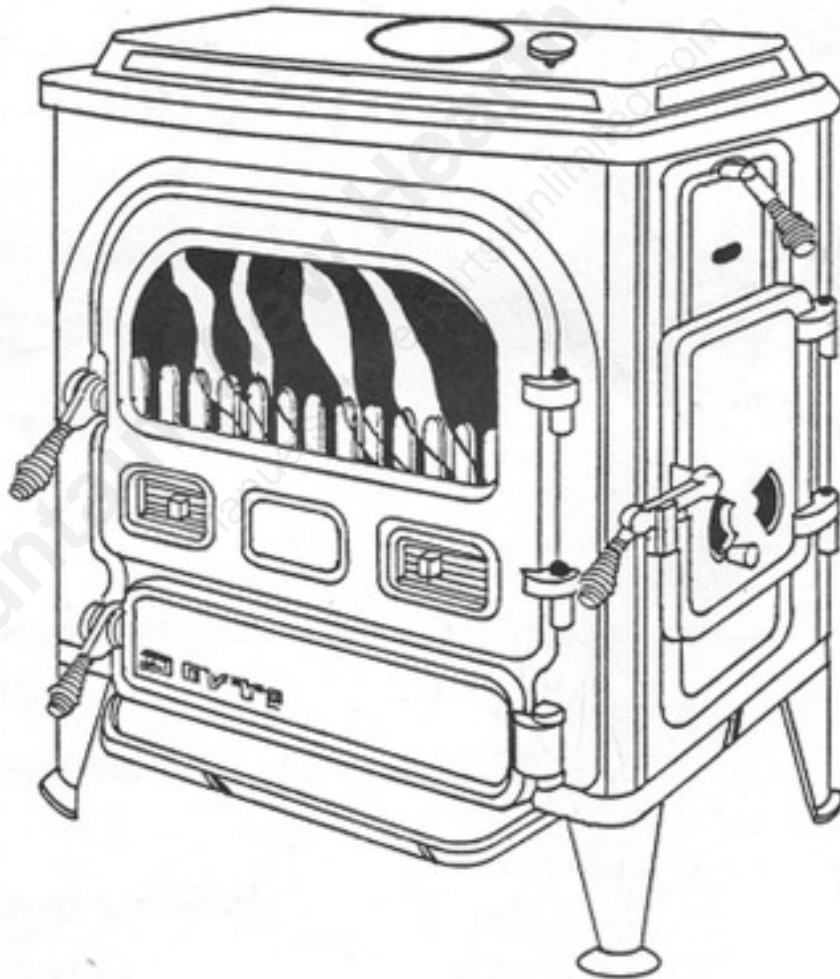

INSTALLATION AND OPERATION MANUAL

The Horizon Stove



MODEL 500CC



INDEX

I. INSTALLATION SECTION

INTRODUCTION

PLANNING INSTALLATION.....	1
ASSEMBLY.....	1
CHIMNEY.....	4
STOVEPIPE.....	5
TEMPERATURE PROBE.....	5
CLEARANCES.....	6
FLOOR PROTECTION.....	7
WALL PROTECTION.....	8

II. OPERATION SECTION

OPERATION.....	9
BUILDING FIRST FIRE.....	11
FUELS.....	12
ASH HANDLING.....	12
CLEANING & GENERAL MAINTENANCE.....	13
TROUBLE SHOOTING.....	14
WARRANTIES.....	15

SECTION I

PLANNING INSTALLATION

PLANNING YOUR STOVE INSTALLATION WILL HELP MAKE THE JOB GO SMOOTHLY AND SAFELY. WHILE YOUR DOVRE APPLIANCE IS LISTED BY UL AND ULC, IT IS STILL IMPORTANT TO CHECK LOCAL AND STATE BUILDING CODES BEFORE BEGINNING THE INSTALLATION. YOU MAY BE REQUIRED TO OBTAIN A BUILDING PERMIT IN SOME AREAS. THIS CAN BE ACCOMPLISHED BY CONTACTING YOUR BUILDING INSPECTOR.

IN ADDITION, WE RECOMMEND THAT YOU NOTIFY YOUR INSURANCE COMPANY REPRESENTATIVE AS SOME HOMEOWNER'S INSURANCE COMPANIES REQUIRE AN INSPECTION OF YOUR INSTALLATION. THIS CAN GIVE YOU THE ADDED SAFETY OF AN OUTSIDE OPINION OF THE INSTALLATION.

FINDING THE RIGHT LOCATION FOR YOUR STOVE IS A BIG PART OF THE PLANNING PROCESS. YOUR STOVE IS A RADIANT ROOM HEATER AND DEPENDS ON GOOD AIR CIRCULATION TO MOVE THE HEAT GENERATED. THEREFORE, A CENTRAL LOCATION IS BEST IF YOU ARE DEPENDING ON YOUR STOVE AS THE PRIMARY HEAT SOURCE. IF YOUR STOVE IS TO BE A ZONE OR SECONDARY HEAT SOURCE, CONSIDER PLACING IT IN A HARD-TO-HEAT AREA OR IN THE MAIN LIVING AREA. OF COURSE, IF YOU ARE GOING TO USE AN EXISTING CHIMNEY, YOU MAY HAVE TO COMPROMISE SOMEWHAT ON THE LOCATION. IF THIS IS GOING TO CAUSE TOO MUCH OF A PROBLEM, YOU MAY ELECT TO CONSTRUCT A NEW FACTORY-BUILT CHIMNEY INSTEAD. SEE THE SECTIONS ON WALL AND FLOOR PROTECTION ON PAGE 7 AND PAGE 8.

THE DOVRE HORIZON IS NOT APPROVED FOR INSTALLATION IN MOBILE HOMES.

OTHER RECOMMENDED READING FOR SOLID FUEL USERS ARE:

1. VIVIAN, WOOD HEAT
RODALE PRESS, 1976
ISBN 0-87857-149-3 PAPERBACK
2. SHELTON & SHAPIRO, THE WOODBURNER'S ENCYCLOPEDIA
VERMONT CROSSROADS PRESS, 1977
ISBN 0-915248-08-5 PAPERBACK
3. SHELTON, SOLID FUELS ENCYCLOPEDIA
GARDEN WAY PUBLISHING, 1983
ISBN 0-88266-307-0 PAPERBACK

ASSEMBLY

SINCE A CAST IRON HEATER IS HEAVY, IT IS EASIER TO ASSEMBLE AND INSTALL WITH TWO PEOPLE. BEFORE STARTING ASSEMBLY, PLACE THE UNIT NEAR THE FINAL POSITION, THEN FOLLOW THE PROCEDURE BELOW:

1. OPEN THE STOVE AND REMOVE ALL PARTS AND ARTICLES PACKED INSIDE. OPEN THE BOX FOUND IN THE UNIT, CHECK THE PARTS LIST AND INSPECT ALL PARTS AND THE CAST IRON BODY FOR SHIPPING DAMAGE. CONTACT YOUR DEALER IF ANY IRREGULARITIES ARE NOTICED. YOU SHOULD ALSO REMOVE THE GLASS DOOR, THE SIDE LOADING DOOR, GRATES, LOG RETAINER, SIDE & BACK BURN PLATES AND ASH PAN TO MAKE THE UNIT LIGHTER AND EASIER TO MANUEVER.

2. NOW GENTLY LAY THE UNIT ON ITS BACK AND ATTACH THE LEGS AND ASH LIP (SEE FIG. 1).
3. INSTALL FLOOR PROTECTION IF THE HEATER IS BEING PLACED ON A COMBUSTIBLE FLOOR. REFER TO THE SECTION ON FLOOR PROTECTORS FOR REQUIRED MATERIALS AND SIZES.
4. LIFT - **DO NOT TILT ON THE CAST IRON LEGS** - THE UNIT TO THE UPRIGHT POSITION AND PLACE IT ON THE FLOOR PROTECTOR.
5. REPLACE THE 3 BURN PLATES, LOG RETAINERS, GRATES, AND ASH PAN INSIDE THE STOVE (SEE FIG. 2).

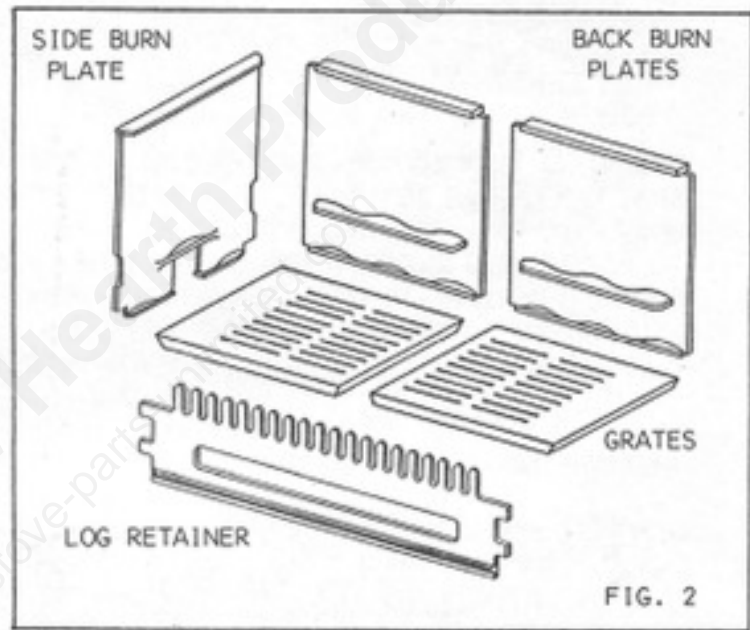
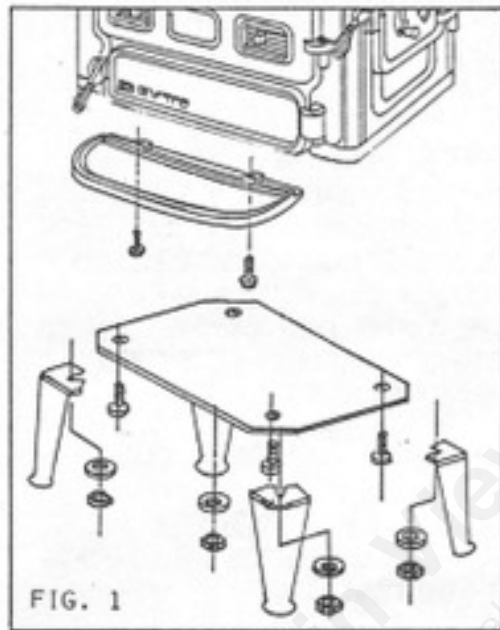

6. RETURN THE GLASS DOOR AND THE SIDE LOADING DOOR TO THEIR HINGES. ATTACH THE 4 SPRING HANDLES TO THE 3 DOOR LATCHES AND BYPASS DAMPER LEVER.
7. THE FLUE COLLAR IS LOCATED IN THE BOX THAT WAS INSIDE THE HEATER. FOR A TOP FLUE EXIT, ATTACH THE COLLAR TO THE TOP OF THE HEATER WITH BOLTS AND NUTS PROVIDED. FURNACE CEMENT MAY BE USED TO SEAL UNDER THE COLLAR (SEE FIG. 3). SHOULD A REAR FLUE EXIT BE NECESSARY, YOU WILL NEED TO REMOVE THE BACK SHEET METAL COVER PLATE FROM THE BACK SHIELD. THE FLUE COLLAR IS THEN FASTENED TO THE BACK OF THE UNIT WITH THE BOLTS AND NUTS PROVIDED, AS SHOWN IN FIG. 3. INSTALL THE CAST IRON COVER PLATE ON THE TOP OF THE HEATER IN THE UNUSED FLUE OPENING BY PLACING A BEAD OF FURNACE CEMENT AROUND THE EDGE AND PLACE THE COVER IN POSITION SO IT SITS FIRMLY AGAINST THE CAST IRON. FOR ATTACHING THE COVER PLATE TO THE REAR OF THE STOVE, YOU WILL ALSO NEED TO ATTACH THE FIXING BAR TO THE COVER PLATE WITH THE BOLT AND WASHERS PROVIDED. SEE FIG. 4 FOR TOP COVER PLATE AND FIG. 5 FOR REAR COVER PLATE INSTALLATION.

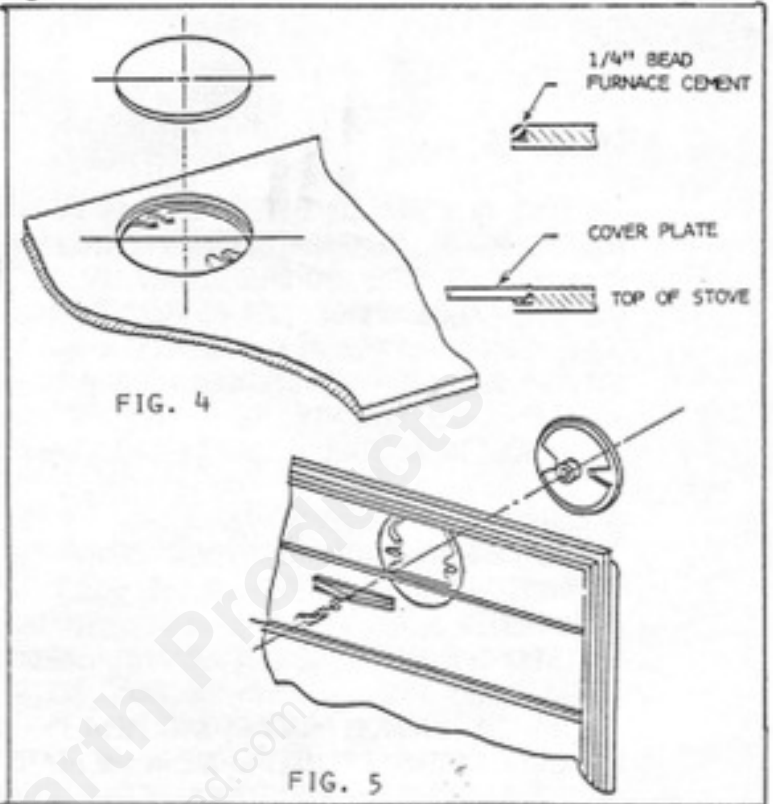
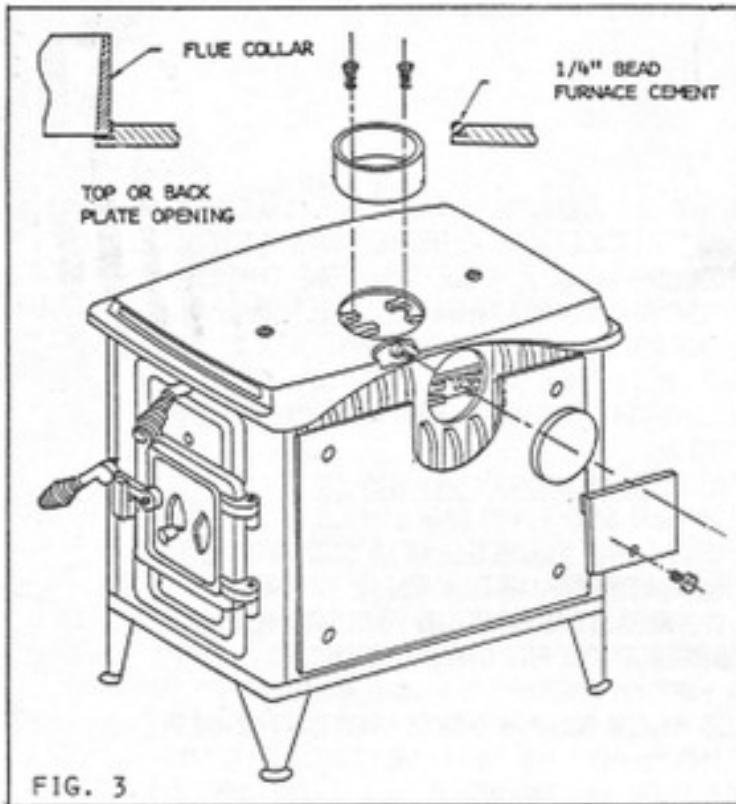

8. REMOVE THE TOP PLATE OF THE STOVE BY TAKING OUT THE TWO ALLEN HEAD CAP SCREWS WITH THE ALLEN WRENCH PROVIDED. CHECK PLACEMENT & OPERATION OF THE INTERNAL BYPASS AND COMBUSTOR PARTS, USING THE DIAGRAM IN FIG. 5.

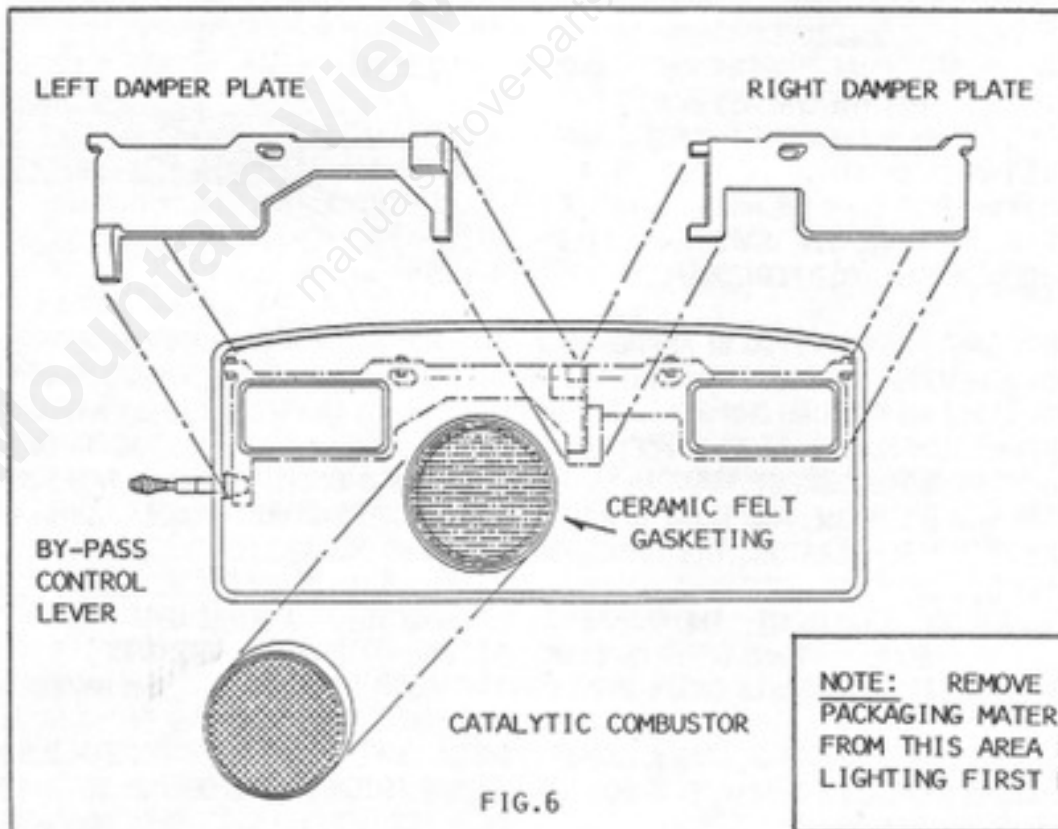

9. INSTALL THE CHIMNEY CONNECTOR BETWEEN THE HEATER AND THE CHIMNEY.

CHIMNEYS

THE VENTING SYSTEM CONSISTS OF A CHIMNEY CONNECTOR AND A CHIMNEY. THESE GET EXTREMELY HOT DURING USE. TEMPERATURES INSIDE THE CHIMNEY MAY EXCEED 2000 DEGREES IN THE EVENT OF A CREOSOTE FIRE. TO PROTECT AGAINST THE POSSIBILITY OF A HOUSE FIRE, THE CHIMNEY CONNECTOR AND CHIMNEY MUST BE PROPERLY INSTALLED AND MAINTAINED. A THIMBLE MUST BE USED WHEN A CONNECTION IS MADE THROUGH A COMBUSTIBLE WALL TO A CHIMNEY. A CHIMNEY SUPPORT PACKAGE MUST BE USED WHEN A CONNECTION IS MADE THROUGH THE CEILING TO A PRE-FABRICATED CHIMNEY. THESE ACCESSORIES ARE ABSOLUTELY NECESSARY TO PROVIDE SAFE CLEARANCES TO COMBUSTIBLE WALL AND CEILING MATERIAL.

OF COURSE, THE CHIMNEY IS RESPONSIBLE FOR VENTING OUT SMOKE AND GASES. THIS IS DONE BY CHIMNEY DRAFT. DRAFT IS A FUNCTION OF THE HEIGHT AND DIAMETER OF A CHIMNEY FLUE COMBINED WITH FLUE TEMPERATURE VERSUS OUTSIDE AIR TEMPERATURE. A WARM CHIMNEY WILL DRAW BETTER ON A COLD DAY THAN ON A MILD DAY. THE AMOUNT OF DRAFT IN YOUR CHIMNEY MAY ALSO BE DEPENDENT ON LOCAL GEOGRAPHY, NEARBY OBSTRUCTIONS, AND OTHER FACTORS.

THE HORIZON MINIMUM DRAFT REQUIREMENT IS $-.055$ WATER COLUMN INCHES. TOO MUCH DRAFT MAY CAUSE EXCESSIVE TEMPERATURE IN THE HEATER AND MAY DAMAGE THE CATALYTIC COMBUSTOR. INADEQUATE DRAFT MAY CAUSE BACKPUFFING INTO THE ROOM AND "PLUGGING" OF THE CHIMNEY OR THE CATALYST.

THE NFPA, AND MOST LOCAL CODES, STATE THAT CHIMNEYS MUST BE THE REQUIRED HEIGHT ABOVE THE ROOF OR OTHER OBSTRUCTIONS FOR SAFETY AND FOR PROPER DRAFT OPERATION. THE REQUIREMENT IS THAT THE CHIMNEY MUST BE AT LEAST 3 FEET HIGHER THAN THE HIGHEST POINT WHERE IT PASSES THROUGH THE ROOF AND AT LEAST 2 FEET HIGHER THAN THE HIGHEST PART OF THE ROOF OR STRUCTURE THAT IS WITHIN 10 FEET OF THE CHIMNEY, MEASURED HORIZONTALLY.

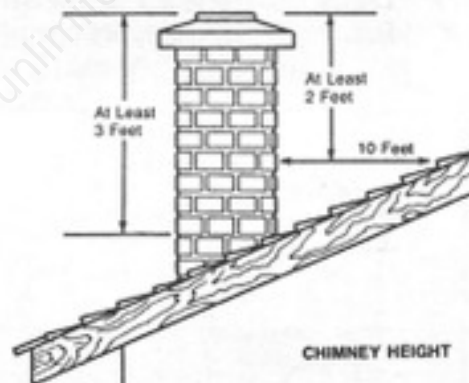

EXISTING MASONRY CHIMNEYS MAY BE APPROPRIATE FOR YOUR UNIT IF THE CHIMNEY FLUE DOES NOT SERVE ANY OTHER APPLIANCE. A DOVRE UNIT REQUIRES A MINIMUM 6" DIAMETER FLUE. IF YOU ARE PLANNING TO USE AN EXISTING CHIMNEY, FIRST HAVE IT CLEANED AND INSPECTED BY A QUALIFIED PROFESSIONAL TO INSURE THAT IT IS ACCEPTABLE TO THE LOCAL AUTHORITIES AND IS IN GOOD CONDITION. **DO NOT CONNECT YOUR UNIT TO AN UNLINED CHIMNEY.** FLUE GASES COULD PENETRATE INTO THE HOUSE, AND THERE IS A DANGER OF EXPOSING NEARBY WOODEN MEMBERS OF THE HOUSE TO HIGH TEMPERATURE, DUE TO POSSIBLE DRIED AND CRACKED MORTAR JOINTS.

WARNING STATEMENT: THE CHIMNEY FLUE CONNECTED TO A DOVRE UNIT MUST NOT BE USED TO VENT ANY OTHER COAL, GAS, OIL, OR WOODBURNING APPLIANCE, AS THIS MAY ALLOW HARMFUL GASES INTO THE HOUSEHOLD AIR SUPPLY.

IF YOUR CHIMNEY NEEDS REPAIR, CALL A CHIMNEY MASON. SHOULD YOU DECIDE TO BUILD A NEW MASONRY CHIMNEY, CALL A QUALIFIED MASON AND BE SURE IT IS BUILT TO COMPLY WITH LOCAL CODES, OR NFPA #211.

FACTORY BUILT CHIMNEYS

A FACTORY BUILT CHIMNEY IS A LISTED RESIDENTIAL TYPE AND BUILDING HEATING APPLIANCE CHIMNEY. GENERALLY, IT IS LESS EXPENSIVE TO CONSTRUCT A FACTORY BUILT RATHER THAN A MASONRY CHIMNEY. A FACTORY BUILT CHIMNEY DOES NOT NEED A SPECIAL FOUNDATION AND CAN BE SUPPORTED BY THE ROOF OR CEILING OF YOUR HOUSE. FACTORY BUILT CHIMNEYS COME IN A NUMBER OF SIZES. YOUR DOVRE UNIT REQUIRES A 6" DIAMETER PIPE. BE SURE TO FOLLOW THE CHIMNEY MANUFACTURERS INSTALLATION INSTRUCTIONS.

STOVE PIPE OR CHIMNEY CONNECTOR

YOUR DOVRE UNIT NEEDS 6" SINGLE-WALL CHIMNEY TO CONNECT THE UNIT TO THE CHIMNEY FLUE. BY PLACING THE UNIT AS CLOSE TO THE CHIMNEY AS ALLOWED BY CLEARANCES TO COMBUSTIBLES, YOU WILL KEEP THE STOVEPIPE AS SHORT AND STRAIGHT AS POSSIBLE. THIS WILL ALLOW THE SMOKE AND EXHAUSTED GAS TO FLOW SMOOTHLY INTO THE CHIMNEY. HORIZONTAL SECTIONS OF STOVEPIPE SHOULD BE KEPT SHORT, AS THEY COLLECT SOOT AND CREOSOTE MORE EASILY AND, THEREFORE, REQUIRE CLEANING MORE OFTEN.

ANY HORIZONTAL RUN OF STOVEPIPE MUST HAVE A SLIGHT RISE AWAY FROM THE UNIT OF 1/4" PER FOOT OF PIPE. THIS WILL DIRECT ANY CONDENSATE FLOW BACK INTO THE UNIT WHERE IT CAN BE BURNED SAFELY.

THE STOVEPIPE MUST BE A MINIMUM THICKNESS OF 24 GAUGE BLACK OR BLUED STEEL, OR STAINLESS STEEL. NEVER USE GALVANIZED STEEL OR ALUMINUM PIPE. THEY CANNOT PROPERLY WITHSTAND THE EXTREME TEMPERATURES OF A WOOD FIRE. THE CRIMPED END OF EACH PIPE MUST POINT DOWNWARD, OR TOWARD THE UNIT (SEE FIG. 7). THIS KEEPS ANY CONDENSATE FROM LEAKING OUT AT A PIPE JOINT. IN ADDITION, SECURE EACH PIPE JOINT WITH THREE SHEET METAL SCREWS TO PREVENT SEPARATION DURING USE.

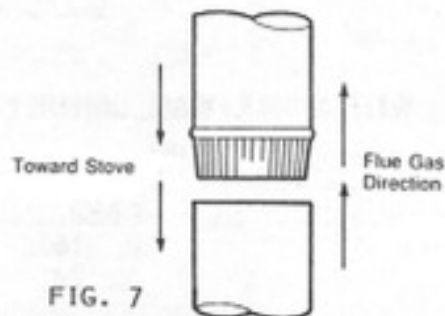

A LISTED DOUBLE-WALL CHIMNEY CONNECTOR OR LISTED CONNECTORS MAY BE USED IN CONJUNCTION WITH AN OPTIONAL BACKSHIELD TO REDUCE THE CLEARANCES TO THE BACKWALL. SEE THE CLEARANCE TABLE IN THE FOLLOWING SECTION.

CATALYTIC PROBE THERMOMETER (CPT)

EACH UNIT IS PROVIDED WITH A TEMPERATURE PROBE AND AN ACCESS HOLE ON THE TOP PLATE OF THE UNIT. THE PROBE IS PROVIDED IN THE CORRECT LENGTH TO MONITOR THE TEMPERATURE OF THE GASES COMING OUT OF THE CATALYTIC COMBUSTOR (SEE FIG. 8).

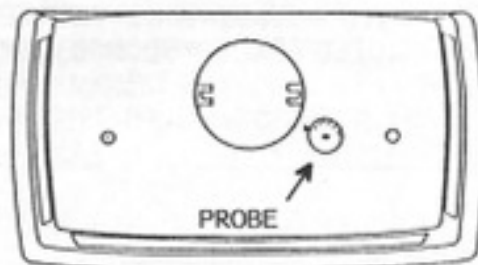

FIG. 8

CLEARANCES

IT IS IMPORTANT TO NOTE THAT SIMPLY COVERING A COMBUSTIBLE MATERIAL WITH A NON-COMBUSTIBLE MATERIAL DOES NOT ALWAYS OFFER SUFFICIENT HEAT PROTECTION. FOR EXAMPLE, DRYWALL CONDUCTS THE RADIANT HEAT DIRECTLY TO THE WOOD, AND THE EFFECT IS THE SAME AS IF THE WOOD WAS UNPROTECTED.

CLEARANCES TO A COMBUSTIBLE BACKWALL MAY BE REDUCED TO 8" BY USING DOVRE BACKSHIELD, PART #500HSB, AND A LISTED DOUBLE-WALL CONNECTOR PIPE. THE SIDE SHIELD, PART #500HSS, MAY ALSO BE USED TO REDUCE THE SIDEWALL CLEARANCES TO A MINIMUM OF 12".

THE FOLLOWING TABLE AND DIAGRAMS SHOW THE MINIMUM CLEARANCE REQUIREMENTS BETWEEN YOUR DOVRE HORIZON, CHIMNEY CONNECTORS AND UNPROTECTED COMBUSTIBLE WALLS AND MATERIALS.

WARNING STATEMENT: COMPLIANCE WITH ALL MINIMUM CLEARANCES SHOWN IN THE MANUAL IS NECESSARY FOR YOUR SAFETY.

HORIZON (MODEL 500CC) CLEARANCE TABLE & DIAGRAMS

WITH SINGLE-WALL CHIMNEY CONNECTOR:

<u>FLUE CONNECTION</u>		<u>BACKWALL</u>	<u>SIDEWALL</u>	<u>CEILING</u>
<u>TOP</u>	<u>REAR</u>			
X		16"	20"	18"
	X	24"	20"	--

WITH DOUBLE-WALL CHIMNEY CONNECTOR AND DOVRE REAR HEAT SHIELD (PART #500HSB)

<u>FLUE CONNECTION</u>		<u>BACKWALL</u>	<u>SIDEWALL</u>	<u>CEILING</u>
<u>TOP</u>				
X		8"	20"	18"

WITH DOUBLE-WALL CHIMNEY CONNECTOR WITH BOTH DOVRE REAR HEAT SHIELD (PART #500HSB) AND DOVRE SIDE HEAT SHIELD (PART #500HSS)

<u>FLUE CONNECTION</u>		<u>BACKWALL</u>	<u>SIDEWALL</u>	<u>CEILING</u>
<u>TOP</u>				
X		8"	12"	18"

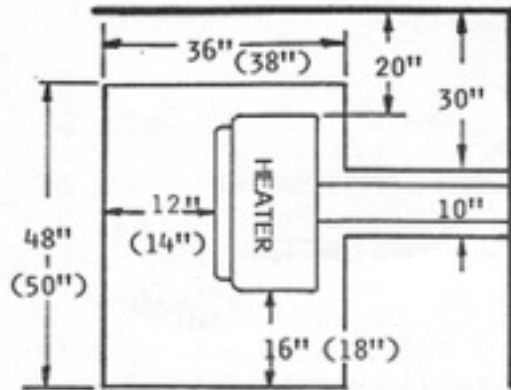

SIDEWALL CLEARANCES AND FLOOR PROTECTOR SIZE

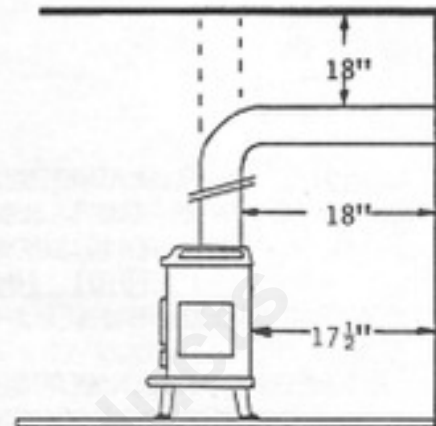

BACKWALL CLEARANCES WITH TOP FLUE CONNECTION

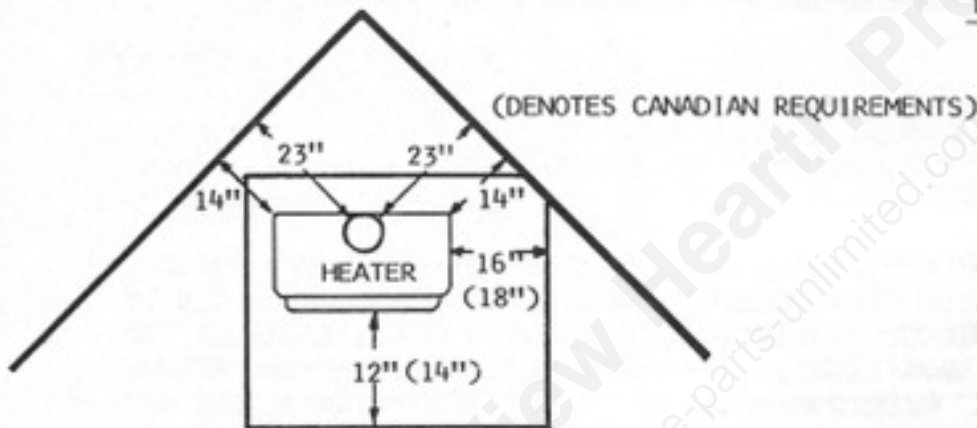

STANDARD 45° CORNER INSTALLATION

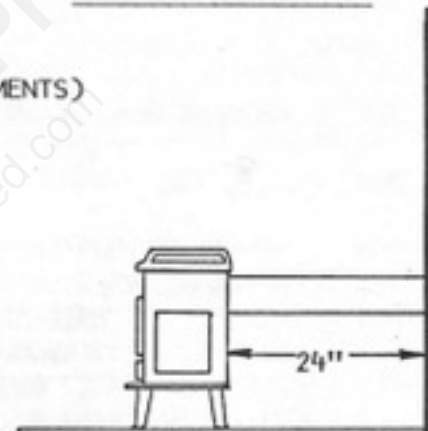

BACKWALL CLEARANCES WITH REAR FLUE CONNECTION

FLOOR PROTECTION

A COMBUSTIBLE FLOOR MUST BE PROTECTED FROM THE RADIANT HEAT GIVEN OFF BY THE STOVE AND FROM THE INEVITABLE SPARK OR FALLING EMBER. THIS INCLUDES ALMOST ANY FLOOR SURFACE. ONLY A SOLID MASONRY OR CONCRETE FLOOR ADEQUATELY COVERING THE DISTANCE AROUND YOUR UNIT IS ACCEPTABLE. A LAYER OF THIN BRICK OR CERAMIC TILE OVER A COMBUSTIBLE FLOOR IS INSUFFICIENT.

TO PROTECT YOUR FLOOR, IT IS NECESSARY TO INSTALL A FLOOR PROTECTOR OF ONE LAYER OF 3/8" NON-COMBUSTIBLE MILLBOARD HAVING A THERMAL CONDUCTIVITY OF $K = 0.84 \text{ BTU IN/FT}^2 \text{ HR F}$, OR AN EQUALLY THICK LISTED FLOOR PROTECTOR. THE REQUIRED DIMENSIONS OF FLOOR PROTECTOR VARY ACCORDING TO THE LENGTH OF CHIMNEY CONNECTOR AS SHOWN. IF YOU CONSTRUCT YOUR OWN FLOOR PROTECTOR WITH THE ONE LAYER OF MILLBOARD, WE SUGGEST THAT IT THEN BE COVERED WITH CERAMIC TILE, OR THIN BRICK, AND FRAMED TO PROTECT THE MILLBOARD AND GIVE IT A FINISHED LOOK.

ANY HORIZONTAL LENGTH OF CHIMNEY CONNECTOR PIPE MUST ALSO HAVE THE FLOOR PROTECTOR BENEATH IT AND EXTENDING 2" ON EACH SIDE OF THE PIPE. THE REQUIRED FLOOR PROTECTOR SIZE FOR MODEL 500CC IS 48" X 36". IN CANADA, A FLOOR PROTECTOR OF 50" X 38" IS REQUIRED.

NOTE: IN CALCULATING EQUIVALENT THICKNESS OF ALTERNATE MATERIALS, THE FOLLOWING FORMULA SHOULD BE USED:

ONE LAYER OF 3/8" (0.375 INCH) THICK MILLBOARD HAS A K FACTOR OF
$$\frac{\text{(BTU)} \text{ (INCH)}}{0.21 \text{ (HR)} \text{ (FT}^2\text{)} \text{ (}^{\circ}\text{F)} \text{ AT } 75^{\circ}\text{F}}$$

IF COMMON BRICK WERE BEING USED AS AN ALTERNATE MATERIAL WITH A K FACTOR OF 5.0 AT 75°F, THE THICKNESS REQUIRED WOULD BE AS FOLLOWS:

REQUIRED THICKNESS = (K OF BRICK/K OF MILLBOARD) X (THICKNESS OF MILLBOARD) OR (5/0.21) X 3/8 IN. = 9 IN. OF BRICK - MINIMUM.

WALL PROTECTION

YOUR DOYRE UNIT HAS BEEN TESTED AND APPROVED FOR INSTALLATION WITHOUT ANY SPECIAL PROTECTION FOR THE WALLS AROUND IT, AS LONG AS THE NECESSARY CLEARANCES BETWEEN THE UNIT, STOVEPIPE, AND WALL ARE MAINTAINED. (SEE DIAGRAM UNDER "CLEARANCES" FOR DETAIL). HOWEVER, IF YOU WANT TO REDUCE THE REQUIRED DISTANCE BETWEEN THE UNIT AND WALLS, YOU MAY CONSTRUCT OR PURCHASE A WALL PROTECTOR OR USE AN OPTIONAL REAR HEAT SHIELD ATTACHMENT, (PART #500HSB) WHICH REDUCES THE CLEARANCE TO AN UNPROTECTED REAR WALL TO A MINIMUM 8" FROM THE UNIT, WHEN USED IN CONJUNCTION WITH A DOUBLE-WALL CONNECTOR PIPE.

IF YOU ELECT TO PURCHASE A WALL PROTECTOR, IT MUST BE LISTED. UNDERWRITER'S LABORATORIES REQUIRE A MINIMUM 12" CLEARANCE BETWEEN ANY STANDARD HEATER AND WALL PROTECTOR. YOUR CHOICE OF A LISTED WALL PROTECTOR WILL DEPEND ON HOW MUCH UNPROTECTED CLEARANCE MAY BE REDUCED. FOR EXAMPLE, A PROTECTOR OFFERING A 2/3 OR 66% REDUCTION WILL ALLOW A 36" CLEARANCE TO BECOME 12"; AND A 1/2 OR 50% REDUCTION WILL CHANGE A 24" CLEARANCE TO 12'. BE SURE TO FOLLOW THE MANUFACTURER'S INSTALLATION INSTRUCTIONS ON ANY LISTED WALL PROTECTOR.

SHOULD YOU DECIDE TO CONSTRUCT A WALL PROTECTOR, BE SURE IT IS APPROVED BY YOUR LOCAL BUILDING CODE OFFICAL. THE MOST COMMON WALL PROTECTOR CONSTRUCTION IS A VENTILATED, NON-COMBUSTIBLE WALL SHIELD.

SECTION II

OPERATION

AS WAS MENTIONED IN THE INTRODUCTION, THE TWO MOST IMPORTANT FACTORS IN THE SAFETY AND RELIABILITY OF YOUR DOVRE UNIT ARE INSTALLING AND OPERATING IT CORRECTLY. SECTION II WILL EXPLAIN HOW TO USE YOUR UNIT SAFELY AND EFFICIENTLY AND MAKE IT LAST FOR YEARS.

A KEY FACTOR IN OPERATING YOUR STOVE SAFELY AND EFFICIENTLY, IS CONTROLLING CREOSOTE. CREOSOTE VARIES IN APPEARANCE FROM A DARK, HEAVY, TAR-LIKE LIQUID TO DARK FLAKES ATTACHED TO THE STOVEPIPE OR CHIMNEY FLUE LINER. IT IS HIGHLY FLAMMABLE, AND IS THE FUEL BURNT DURING A CHIMNEY FIRE. SINCE CHIMNEY FIRES ARE A FRIGHTENING EXPERIENCE AND CAN CAUSE SUBSTANTIAL DAMAGE EVEN TO A WELL-CONSTRUCTED CHIMNEY, **YOUR MOST IMPORTANT JOB IN SAFELY OPERATING THE UNIT IS TO CONTROL THE FORMATION OF CREOSOTE.**

THE HORIZON MODEL 500CC INCORPORATES THE NEWEST COMBUSTION EFFICIENCY TECHNOLOGY WHICH HELPS SUBSTANTIALLY REDUCE CREOSOTE BUILD-UP WHEN OPERATED CORRECTLY. BY BURNING ONLY WELL SEASONED WOOD (LESS THAN 20% MOISTURE), AND THROUGH PROPER UTILIZATION OF THE CATALYTIC COMBUSTOR AND BYPASS DAMPER WHENEVER THE STOVE IS AT NORMAL OPERATING TEMPERATURE AND THE CPT IS OVER 400 DEGREES FAHRENHEIT.

WARNING STATEMENT: CREOSOTE & SOOT - FORMATION AND NEED FOR REMOVAL - WHEN WOOD IS BURNED SLOWLY, IT PRODUCES TAR AND OTHER ORGANIC VAPORS, WHICH COMBINE WITH EXPELLED MOISTURE TO FORM CREOSOTE. THE CREOSOTE VAPORS CONDENSE IN THE RELATIVELY COOL CHIMNEY FLUE OF A SLOW-BURNING FIRE. AS A RESULT, CREOSOTE RESIDUE ACCUMULATES ON THE FLUE LINING. WHEN IGNITED, THIS CREOSOTE MAKES AN EXTREMELY HOT FIRE.

THE CHIMNEY CONNECTOR AND CHIMNEY SHOULD BE INSPECTED TWICE MONTHLY DURING THE HEATING SEASON TO DETERMINE IF A CREOSOTE BUILD-UP HAS OCCURED.

TO LET IN TOO MUCH AIR TO AN OVERLOADED FIREBOX CAN RESULT IN A VERY HOT FIRE WHICH IS DANGEROUS AND IS BURNING TOO FAST TO LET THE CAST IRON PULL MOST OF THE BTU'S OR HEAT, INTO THE ROOM. TOO MUCH HEAT IS THEN LOST UP THE CHIMNEY AND EFFICIENCY IS REDUCED.

WARNING STATEMENT: DO NOT OVERFIRE YOUR DOVRE UNIT. IF ANY PART OF THE APPLIANCE STARTS TO GLOW, YOU ARE OVERFIRING. STOP ADDING FUEL, CLOSE THE DOORS TIGHTLY, AND CLOSE DRAFT CONTROLS COMPLETELY UNTIL THE GLOWING HAS STOPPED.

DO NOT BURN LARGE QUANTITIES OF PAPER IN YOUR UNIT. THIS WILL CAUSE AN EXTREMELY HOT FIRE THAT COULD IGNITE ANY CHIMNEY CREOSOTE TO FORM IN THE CHIMNEY. IN ADDITION, NEVER BURN TRASH, PLASTIC OR OTHER CHEMICALS IN YOUR UNIT WHICH MAY DO CORROSIVE DAMAGE TO THE CHIMNEY FLUE LINING, OR DANGEROUS GASES TO BE RELEASED INTO THE AIR. AVOID BURNING WET OR GREEN WOOD AND DRIFTWOOD WHICH CAN CAUSE CREOSOTE. USE SEASONED WOOD (PREFERABLY TWO YEARS).

WARNING STATEMENT: A SMOKE ALARM IS RECOMMENDED FOR THE ROOM IN WHICH THE UNIT IS LOCATED. IN THE EVENT OF A CHIMNEY FIRE, IMMEDIATELY:

- A. CLOSE THE UNIT DOORS AND DRAFT CONTROLS COMPLETELY.
- B. CALL THE FIRE DEPARTMENT.
- C. EVACUATE THE HOUSE.

A MAJOR FEATURE OF A DOVRE UNIT IS ITS PREMIUM, QUALITY CAST IRON BODY. CAST IRON HAS BEEN USED TO HOLD FIRE FOR SEVERAL HUNDRED YEARS IN EUROPE. A PRIMARY REASON FOR CHOOSING TO BUILD OUR UNITS WITH CAST IRON IS ITS PROVEN DURABILITY. UNLIKE COMMON PLATE STEEL, DOVRE CAST IRON WILL EXPAND AND CONTRACT WITHOUT LOSING ITS ORIGINAL SHAPE OR STRENGTH, WHEN REPEATEDLY EXPOSED TO THE TEMPERATURES OF SOLID FUEL BURNING. BECAUSE IT DOES NOT WARP OR CHANGE SHAPE, OUR CAST IRON IS IDEALLY SUITED TO MAINTAINING THE REQUIRED AIRTIGHT CONSTRUCTION NECESSARY IN A DOVRE UNIT.

ANOTHER CAST IRON ADVANTAGE IS ITS SUPERIOR ABILITY TO EFFECTIVELY TRANSMIT THE HEAT FROM THE FIRE CHAMBER INTO THE SURROUNDING AREA. THIS CHARACTERISTIC OF MINIMAL HEAT RESISTANCE AND EVEN TEMPERATURE DISPERSAL IS AS IMPORTANT TO A DOVRE UNIT AS IT HAS BEEN TO OLD FASHIONED CAST IRON FRYING PANS.

WARNING STATEMENT: SINCE THE OUTSIDE SURFACE OF THE CAST IRON DOORS BECOMES VERY HOT, YOU SHOULD USE A GLOVE OR OTHER HAND PROTECTION WHEN OPERATING THE APPLIANCE. THIS WILL ELIMINATE ACCIDENTAL SKIN BURNS. BE SURE TO WARN CHILDREN TO NEVER TOUCH THE UNIT WHEN IT IS IN OPERATION WITHOUT PROPER SKIN PROTECTION.

KEEP ALL HOUSEHOLD COMBUSTIBLES FAR AWAY FROM THE DOORS.

TO INSURE YOUR CAST IRON PROVIDES THE YEARS OF SATISFACTION IT IS CAPABLE OF, YOU MUST ALSO REMEMBER THAT IT IS A SLIGHTLY BRITTLE METAL. IT MAY NOT WITHSTAND THE SHOCK OF A SHARP BLOW OR A SUDDEN TEMPERATURE CHANGE, SUCH AS POURING WATER ON A HOT STOVE. PLACING AN ICE-LADEN LOG AGAINST THE HOT CAST IRON CAN ALSO CAUSE THERMAL SHOCK AND CRACK THE METAL. ADDITIONALLY, CONTACT WITH WATER WILL POSSIBLY CAUSE RUST TO FORM. SHOULD THIS OCCUR, CLEAN THE METAL SURFACE AND COVER WITH TOUCH UP PAINT WHEN THE UNIT IS NOT OPERATING.

TO MORE QUICKLY ACHIEVE BEST RESULTS OPERATING YOUR HEATER, WE STRONGLY RECOMMEND THE USE OF A STOVE TOP SURFACE THERMOMETER. THIS THERMOMETER HELPS YOU MONITOR HEAT OUTPUT, SO YOU CAN QUICKLY LEARN THE EFFECT OF DIFFERENT AIR CONTROL SETTINGS, AND THE RELATIONSHIP BETWEEN STOVE TEMPERATURE AND ROOM TEMPERATURE. IN ADDITION, THE MODEL 500CC HAS A CATALYTIC PROBE THERMOMETER (CPT) WHICH TELLS YOU HOW THE CATALYTIC COMBUSTOR IS WORKING. THIS INDICATOR IS CRITICAL TO THE DAILY OPERATION OF THE MODEL 500CC.

THE MODEL 500CC ALSO CONTAINS A DAMPER BYPASS SYSTEM. THE BYPASS DAMPER AND CATALYTIC COMBUSTOR WORK TOGETHER. THE BYPASS MUST BE OPEN WHEN THE COMBUSTOR IS NOT HOT ENOUGH TO IGNITE (CPT 400° F TO 500° F), AND ANYTIME YOU OPEN A DOOR ON THE UNIT. OTHERWISE, WHENEVER THE CPT READING IS OVER 400° TO 500° F AND THE HEATER DOORS ARE CLOSED, THE BYPASS DAMPER SHOULD BE CLOSED FOR BEST EFFICIENCY AND EMISSION RESULTS.

BUILDING FIRST WOOD FIRE:

OPEN EITHER THE SIDE OR FRONT LOADING DOOR AND THE BYPASS DAMPER CONTROL (TURNED TO IP POSITION). BUILD A SMALL FIRE USING PAPER AND DRY KINDLING. AFTER LIGHTING THE FIRE, CLOSE THE DOOR AND OPEN THE DRAFT CONTROLS (BOTH FRONT AND SIDE) TO THE FULL-OPEN POSITION.

ONCE A 1"-2" BED OF COALS HAS BEEN ESTABLISHED, ADD 2 OR 3 MEDIUM SIZE SPLIT LOGS (ABOUT 2"-4" DIAMETER), KEEPING THE BYPASS DAMPER AND DRAFT INLETS OPEN. NORMALLY AFTER 15 TO 30 MINUTES AND THE CATALYST TEMPERATURE IS 400° TO 500° F, THE CATALYST WILL BE OPERATING. THEN CLOSE THE BYPASS DAMPER.

TO REDUCE THE AMOUNT OF HEAT PRODUCED BY YOUR UNIT, START BY CLOSING THE SIDE DRAFT INLET AND THEN ADJUSTING THE FRONT DRAFT CONTROLS. BY CLOSING THE SIDE DRAFT INLET FIRST AND THEN ADJUSTING THE FRONT DRAFT INLETS, YOU WILL CONTROL THE STOVES HEAT OUTPUT AND MAINTAIN A DESIRABLE ROOM TEMPERATURE.

FOR MAXIMUM HEAT OUTPUT, OPEN THE FRONT DRAFT CONTROLS COMPLETELY AND THE SIDE DRAFT CONTROL TO FULL-OPEN. THIS WILL ALLOW THE UNIT TO PRODUCE 30,000 TO 50,000 BTU/HR WITH SURFACE TEMPERATURES OF 600° TO 900° F.

CATALYTIC PROBE THERMOMETER (CPT) :

DURING START UP OF YOUR DOVRE HORIZON AND DURING THE REFUELING CYCLES, THE TEMPERATURES SHOWN ON YOUR CATALYTIC PROBE THERMOMETER (CPT) WILL TELL YOU HOW YOUR CATALYST IS OPERATING AND WHEN THE BYPASS DAMPER MAY BE CLOSED. THE LOCATION OF THE CPT PROVIDES THE MOST ACCURATE READING, SINCE IT IS DIRECTLY ABOVE THE CATALYTIC COMBUSTOR.

DURING START UP OR REFUELING, THE BYPASS DAMPER IS OPEN. WHEN THE CPT REACHES 400° TO 500° F, THE BYPASS DAMPER MAY BE CLOSED. AT THIS POINT, THE CATALYTIC COMBUSTOR IS HOT ENOUGH TO FUNCTION.

THE INFORMATION FROM A SURFACE THERMOMETER IS VERY HELPFUL IN ADJUSTING THE DRAFT INLETS FOR THE DESIRED HEAT OUTPUT. YOU SHOULD REMEMBER THAT THE TEMPERATURES AND AIR INLET SETTINGS WILL VARY DEPENDING ON THE TYPE OF WOOD, MOISTURE CONTENT OF THE WOOD, AND THE DRAFT OF YOUR CHIMNEY. AS YOU BECOME FAMILIAR WITH YOUR UNIT, YOU WILL DETERMINE THE BEST AMOUNT OF FUEL AND DRAFT SETTING FOR THE HEATING REQUIREMENTS OF YOUR HOME.

INCIDENTALLY, DURING THE FIRST FIRING, YOUR DOVRE UNIT WILL GIVE OFF A SLIGHTLY UNPLEASANT ODOR AS THE HIGH TEMPERATURE PAINT CURES. DON'T BE ALARMED, AS THIS WILL ONLY LAST FOR ABOUT 30 TO 60 MINUTES AFTER THE SURFACE TEMPERATURE ON THE STOVE REACHES 400°F.

ADDING FUEL:

USE THE ASH HOE PROVIDED WITH YOUR UNIT TO SEPERATE HOT COALS FROM THE ASH. BY PUSHING THE ASH TO THE REAR OF THE FUEL BED AND PULLING THE HOT COALS FORWARD TOWARD THE AIR INLET, YOU WILL BE ABLE TO QUICKLY AND EASILY RECHARGE THE FIRE. ADD 2 OR 3 LOGS, CLOSE THE LOADING DOOR AND COMPLETELY OPEN THE DRAFT CONTROL.

WARNING STATEMENT: DO NOT OPERATE YOUR UNIT FOR EXTENDED PERIODS OF TIME WITH SURFACE TEMPERATURES HIGHER THAN 900° F, OR CPT TEMPERATURES OVER 1800° F. YOU MAY DAMAGE THE CATALYST AND THE CASTINGS.

DAILY USE:

BUILD THE FIRES IN THE SAME MANNER AS THE FIRST FIRE - ALWAYS REMEMBERING TO OPEN THE BYPASS DAMPER BEFORE OPENING THE FEED DOOR. ALLOW THE FIRE TO BURN VIGOROUSLY FOR ABOUT 15 TO 30 MINUTES TO IGNITE THE COMBUSTOR. THE COMBUSTOR IGNITES AT ABOUT 400° TO 500° F CPT AND BEGINS TO WORK. ONCE THE COMBUSTOR IS OPERATING, THE BYPASS DAMPER CONTROL CAN BE CLOSED AND THE DRAFT INLETS ADJUSTED FOR THE DESIRED AMOUNT OF HEAT.

FUELS:

THIS DOVRE HEATER IS DESIGNED TO BURN CORD WOOD. THE USE OF OTHER FUELS WILL SHORTEN THE LIFE AND PERFORMANCE OF THE CATALYTIC COMBUSTOR. DO NOT BURN TRASH OR GARBAGE, ARTIFICIAL LOGS, COAL, CHEMICAL STARTERS, DRIFTWOOD, TREATED OR PAINTED WOOD. THESE ALL CONTAIN CHEMICALS THAT MAY CAUSE THE CATALYST TO STOP WORKING PROPERLY.

IF YOU STILL CHOOSE TO OCCASIONALLY ADD COAL TO YOUR WOOD FIRE, THE COMBUSTOR MANUFACTURER RECOMMENDS THE FOLLOWING PROCEDURE. LEAVE THE BYPASS DAMPERS OPEN DURING COAL USAGE, AND WHEN REFUELING WITH WOOD, A HOT START-UP FIRE WILL BE NECESSARY TO BURN COAL RESIDUE FROM THE CATALYST SURFACE. WATCH FOR THE CPT TEMPERATURE TO BE IN THE NORMAL RANGE AFTER CLOSING THE BYPASS DAMPERS TO DETERMINE IF THE COMBUSTOR IS OPERATING NORMALLY AGAIN.

WOOD IS SOLD BY THE CORD, WHICH IS A PILE OF FOUR-FOOT LOGS STACKED FOUR-FEET HIGH AND EIGHT-FEET LONG, OR 128 CUBIC FEET. A CORD OF HARDWOOD WILL GENERALLY WEIGH ABOUT TWO TONS. OBVIOUSLY, THE CORD LOGS MUST BE CUT TO FIT YOUR DOVRE UNIT. THE LOG LENGTH RECOMMENDED FOR A DOVRE HORIZON MODEL 500CC IS 22" - 24".

IF PURCHASING WOOD, LOOK FOR HARDWOOD SUCH AS HICKORY, OAK, BEECH, ROCK MAPLE, AND BLACK WALNUT, AS THEY CONTAIN MORE BTU VALUE PER SQUARE INCH THAN SOFTER WOODS LIKE COTTONWOOD, SYCAMORE, ELM, AND PINE.

ASH HANDLING

USE THE ASH HOE PROVIDED WITH YOUR STOVE TO WORK THE DESIRED AMOUNT OF ASH THROUGH THE GRATE INTO THE ASH PAN. SOME ASH ON THE GRATE IS DESIRABLE TO HELP KEEP AN ACTIVE BED OF COALS FOR REFUELING. WE RECOMMEND EMPTYING THE ASH PAN AT LEAST ONCE A DAY WHEN THE STOVE IS IN CONSTANT OPERATION. **DO NOT LET ASHES BUILD UP IN THE ASH PAN UNTIL THEY REACH THE GRATE AS THIS WILL LEAD TO DETERIORATION OF THE GRATE.**

DISPOSAL OF ASHES

ASHES MUST BE DISPOSED OF CAREFULLY. IT IS CRITICAL TO REMEMBER THAT WHILE YOU MAY NOT SEE ANY RED COALS IN THE ASHES BEING REMOVED, IT IS MOST LIKELY THERE STILL IS SOME RESIDUAL BURNING OCCURRING UNLESS THE FIRE HAS BEEN COLD FOR AT LEAST 48 HOURS OR MORE.

ASHES SHOULD BE PLACED IN A METAL CONTAINER WITH A TIGHT FITTING LID. THE CLOSED CONTAINER OF ASHES SHOULD BE PLACED ON A NON-COMBUSTIBLE FLOOR OR ON THE GROUND, WELL AWAY FROM ALL COMBUSTIBLE MATERIALS, PENDING FINAL DISPOSAL. IF THE ASHES ARE DISPOSED OF BY BURIAL IN SOIL OR OTHERWISE LOCALLY DISBURSED, THEY SHOULD BE RETAINED IN THE CLOSED CONTAINER UNTIL ALL CINDERS HAVE THOROUGHLY COOLED.

CLEANING AND MAINTENANCE

DUSTING WITH A BRUSH OCCASSIONALLY WILL KEEP YOUR DOVRE UNIT CLEAN. IF YOUR DOVRE HAS THE BRASS OPTIONS, **DO NOT USE ANY ABRASIVE CLEANERS OR SOLVENTS** AS THEY COULD DAMAGE THE BRASS FINISH. IF YOUR UNIT HAS THE PORCELAIN OPTION, SIMPLE CLEANING WITH A DAMP CLOTH WILL KEEP IT LOOKING LIKE NEW. REGULARLY CHECK THE DOOR GASKETS FOR ANYTHING THAT MIGHT BE LODGED IN THE FABRIC AND CAUSE DAMAGE.

AT THE END OF THE HEATING SEASON, IT IS RECOMMENDED THAT YOU REMOVE THE SOOT IN THE UNIT WITH A WIRE BRUSH AND INSPECT THE JOINTS AND INNER CAST IRON PARTS FOR DAMAGE. THIS IS ALSO A GOOD TIME TO TOUCH UP THE EXTERIOR PAINT IF NEEDED. SEE YOUR DOVRE DEALER FOR TOUCH-UP PAINT.

FREQUENT INSPECTION OF THE CONNECTOR PIPE AND CHIMNEY SYSTEM ARE IMPORTANT. YOU MAY ELECT TO DO THE CLEANING OF THE CHIMNEY YOURSELF, OR USE A PROFESSIONAL CHIMNEY SWEEP. IF YOU ARE NOT EXPERIENCED IN THIS AREA, WE RECOMMEND HAVING A PROFESSIONAL CHIMNEY SWEEP INSPECT AND CLEAN YOUR CHIMNEY.

YOU MAY NOTICE THE BUILD UP OF SOOT ON YOUR GLASS DOORS AFTER A LONG BURN CYCLE. THIS SOOT WILL BURN OFF DURING A HOT BRISK FIRING PERIOD, WHICH ALWAYS IS RECOMMENDED AFTER AN OVERNIGHT BURN. SHOULD YOU CARE TO CLEAN THE GLASS WITHOUT FIRING THE STOVE, WE RECOMMEND THE USE OF COARSE STEEL WOOL OR SPRAY-ON OVEN CLEANER. JUST SPRAY IT ON AND WIPE IT OFF WITH A SOFT CLOTH. BE SURE THE UNIT DOESN'T CONTAIN A FIRE, AS THE OVEN CLEANER IS FLAMMABLE.

TO REPLACE A BROKEN GLASS, CONTACT YOUR DOVRE DEALER FOR ASSISTANCE. DOVRE UNITS USE ONLY THE HIGHEST QUALITY CERAMIC GLASS AND ANY REPLACEMENT GLASS MUST ALSO BE MADE OF THIS MATERIAL.

TOUBLE SHOOTING

BACK PUFFING - THIS CONDITION IS USUALLY CAUSED BY WEAK DRAFT OR STRONG GUST OF WIND. DRAFT WILL BE WEAKER DURING MILD TEMPERATURES THAN ON COLD DAYS. TO CORRECT A WEAK DRAFT, KEEP THE LOADING DOOR CLOSED AND DRAFT CONTROLS OPEN SO A HOT FIRE CAN BE GENERATED, WHICH WILL HEAT THE CHIMNEY AND STRENGTHEN THE DRAFT. BE SURE THERE ISN'T ANY OBSTRUCTION IN THE CHIMNEY.

DOESN'T BURN OVERNIGHT - THIS IS OFTEN CAUSED BY BURNING TOO LITTLE WOOD OR WOOD THAT IS TOO SMALL IN DIAMETER, OR TOO SOFT, WHICH BURNS TOO RAPIDLY. LOAD WITH FULL SIZE HARDWOOD, AND BE SURE TO REDUCE THE DRAFT CONTROLS TO 1/3 OR LESS FOR OVERNIGHT BURNS. ALSO, CHECK TO SEE THAT GASKETS ARE SEALING WHEN THE DOOR IS CLOSED.

Mountain View Hearth Products
manuals.stove-parts-unlimited.com

WARRANTIES

CATALYTIC COMBUSTOR

THE COMBUSTOR SUPPLIED WITH THIS HEATER IS A CORNING LONG LIFE COMBUSTOR. CONSULT THE CATALYTIC COMBUSTOR WARRANTY ALSO SUPPLIED WITH THIS HEATER. WARRANTY CLAIMS SHOULD BE ADDRESSED TO:

CORNING GLASS WORKS
WARRANTY CLAIM DEPT.
ELECTRONIC MATERIALS PLANT - A DOCK
ADDISON ROAD
PAINTED POST, NY 14870

DOYRE LIMITED 10 YEAR WARRANTY

DOYRE HEATERS ARE MADE OF PREMIUM QUALITY CAST IRON AND CONSTRUCTION MATERIALS. YOUR UNIT IS WARRANTED IN NORMAL HOUSEHOLD USE IN ACCORDANCE WITH THE INSTALLATION AND OPERATING MANUAL AGAINST DEFECTS IN WORKMANSHIP OR MATERIAL FOR A PERIOD OF 10 YEARS FROM THE DATE OF PURCHASE. THIS WARRANTY IS EXTENDED TO ONLY THE ORIGINAL PURCHASER FROM AN AUTHORIZED DOYRE DEALER, AS VERIFIED BY OUR RECEIPT OF THE ENCLOSED WARRANTY REGISTRATION CARD.

THE WARRANTY DOES NOT COVER DAMAGE CAUSED BY ABUSE OR IMPROPER OPERATION. PARTS THAT MAY WEAR OUT SOONER, SUCH AS GRATES, ASH PAN, INNER WALLS, GASKETS, GLASS AND PAINT, ARE NOT COVERED BY THE WARRANTY.

THIS WARRANTY DOES NOT COVER PICK UP, DELIVERY OR HOUSE CALLS. HOWEVER, IF YOU RETURN A PART COVERED BY THIS WARRANTY TO AN AUTHORIZED DOYRE DEALER, FREIGHT PREPAID, WE WILL EITHER REPAIR OR REPLACE THE PART AT OUR OPTION.

THIS WARRANTY GIVES YOU SPECIFIC LEGAL RIGHTS, AND YOU MAY HAVE OTHER RIGHTS WHICH VARY FROM STATE TO STATE AND PROVINCE TO PROVINCE. THE WARRANTY DOES NOT COVER INCIDENTAL OR INCONSEQUENTIAL DAMAGES, AS ALLOWED BY YOUR STATE OR PROVINCIAL LAW.

THIS WARRANTY DOES NOT COVER LABOR COST OF ANY KIND WHATEVER.

DOYRE DEALER: _____

PURCHASE DATE: _____

UL/ULC LABEL NO: _____

DOYRE, INC.
401 HANKES AVE.
AURORA, IL 60505
(312) 844-3353 IN ILLINOIS & CANADA
OUTSIDE OF ILLINOIS, 1-800-DOYRE-US

The Horizon™ Stove

Outshines every one in its class.

Inch for inch, pound for pound, dollar for dollar, the Horizon premium cast iron stove is a better value than other stoves in its class.

This state-of-the-art controlled combustion wood stove produces a generous 50,000 BTU/hour—enough to provide the primary heat source for 1,000 to 1,500 square feet of living space with good room to room circulation.

Horizon accepts 24" logs—up to eight inches longer than comparable stoves—from the front or side for loading convenience. Six inch venting from top or rear coupled with minimal clearance requirements provide excellent installation versatility.

When it comes down to brass tacks, you'll find the Horizon has a more polished appearance than many stove designs. The optional brass accent package plus brass spring handle complement any decor from simple to sophisticated. And the extra large ceramic glass flaunts the fire while a special built-in air wash system keeps the glass clean.

The Horizon stove meets the U.S. EPA 1990 clean burn emission standard and has the safety approval of Underwriters Laboratories. Weighing the facts, we think it will meet your approval, too.



A New Generation in Fireplace Technology

utica
731-2345

The Horizon™ Stove

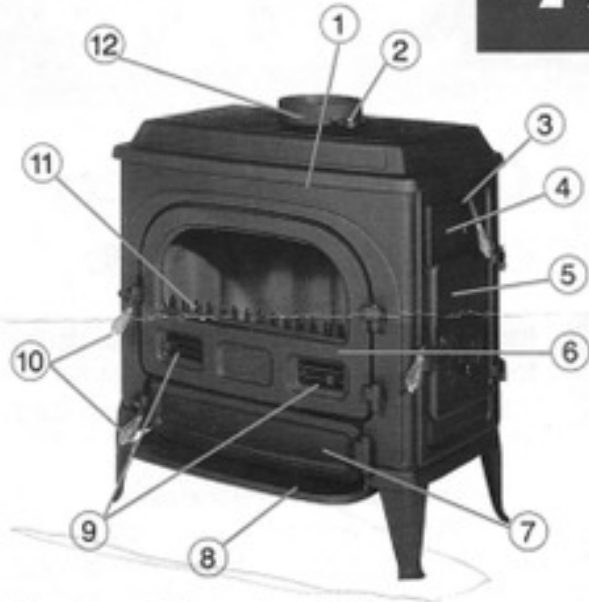

Space saving clearances.

The Horizon woodburning stove is right at home in any room as a distinctive and separate accent. Just vent into wall or ceiling chimney through top or rear exit and allow for clearances—16" back, 20" side (standard) or 8" back, 12" side with optional heatshield using air-cooled stove connector pipe.

Horizon Standard Features

1. Premium quality cast iron construction
2. Catalytic probe thermometer
3. Catalytic bypass control
4. Secondary air inlet
5. Convenient side loading door with auxiliary draft control
6. Fire viewing door with air wash system
7. Ash door, Ash pan
8. Ash lip
9. Primary draft controls
10. Decorative brass spring handles
11. Cast iron log retainer, heavy duty grate
12. Top/Rear flue connection

Optional Features

- Brass accent package
- Back and side heatshields
- 80 CFM fan kit

Dimensions

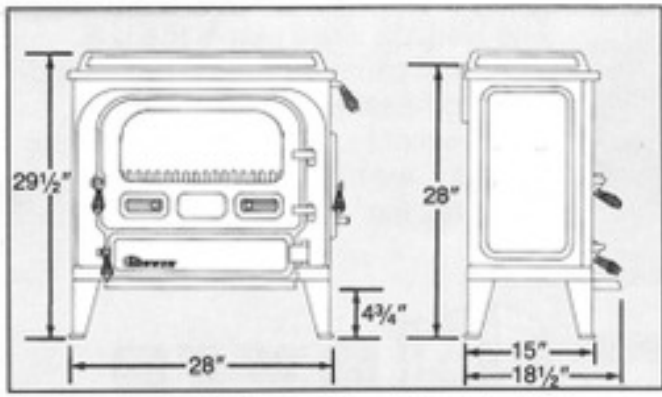

The design of the Dovre Horizon is a trademark of Dovre, Inc. 1987. All rights reserved.

Specifications of Horizon Stove

Maximum Heat Output (Average overall heating efficiency exceeds 75%)	50,000 BTU/hour
Safety Listing	Underwriters Labs. Inc. Underwriters Labs. Canada
Height	29 1/2"
Width	28"
Depth	18 1/2"
Flue Height—Back	28"
Flue Size	6"
Log Length	24" maximum
Materials	Cast iron and ceramic glass
Weight	410 lbs.
Floor Protection Size	48" x 36"
Model Number	500 CC

Important Use only completely dried wood. When burning wood with a high moisture content, a significant quantity of energy will be lost in drying the wood.

10 Year Limited Warranty

Authorized Dovre Dealer

70790 VAN DYKE 4003 HIGHLAND
 ROMEO, MI 48065 WATERFORD, IL 60328
 752-2075 674-3828



DOVRE, INC.
 401 Hankes Avenue
 Aurora, Illinois 60505-1716
 Toll Free 1-800-DOVRE-US
 Inside IL 312-844-3353



A New Generation in Fireplace Technology

