



INSTALLATION AND OPERATION MANUAL

EPA CERTIFIED
CATALYTIC WOOD
BURNING STOVE



www.nficertified.org

We suggest that our wood-burning hearth products be installed and serviced by professionals who are certified in the U.S. by the National Fireplace Institute® (NFI) as NFI Woodburning Specialists or who are certified in Canada by Wood Energy Technical Training (WETT).



RETAIN THESE
INSTRUCTIONS
FOR FUTURE
REFERENCE

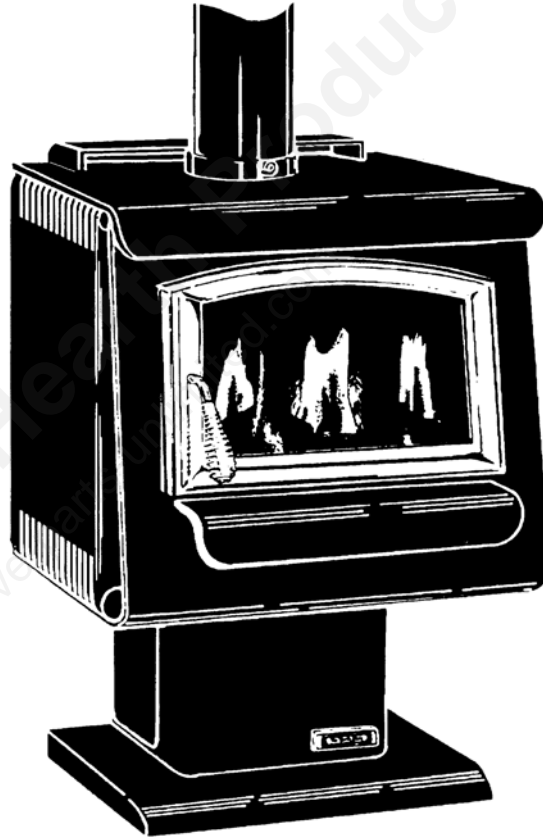

MODEL 1003C

**THIS APPLIANCE MUST BE INSTALLED BY A QUALIFIED INSTALLER.
READ ENTIRE MANUAL THOROUGHLY BEFORE INSTALLATION.**

Tested &
Listed By



Beaverton
Oregon USA

OMNI-Test Laboratories, Inc.

P/N 775003M, Rev. P, 11/03

IMPORTANT WARNINGS

CAUTION: PLEASE READ THIS ENTIRE MANUAL BEFORE YOU INSTALL AND USE YOUR NEW ROOM HEATER. FOR YOUR SAFETY, FOLLOW THE INSTALLATION, OPERATION AND MAINTENANCE INSTRUCTIONS EXACTLY, WITHOUT DEVIATION. FAILURE TO FOLLOW THESE INSTRUCTIONS MAY RESULT IN PROPERTY DAMAGE, BODILY INJURY, OR EVEN DEATH. IF THIS APPLIANCE IS NOT PROPERLY INSTALLED, A HOUSE FIRE MAY RESULT. CONTACT YOUR LOCAL BUILDING OR FIRE OFFICIALS ABOUT RESTRICTIONS AND INSTALLATION INSPECTION REQUIREMENTS IN YOUR AREA.

1. If utilizing an older chimney, it must be inspected for adequate serviceability. Refer to the heading *Chimney Inspection* on page 10 of this manual.
2. The minimum clearances must be maintained for all combustible surfaces and materials including; furniture, carpet, drapes, clothing, wood, papers, etc. Do not store firewood within this clearance space. Failure to maintain clearances to all combustibles may result in a house fire.
3. This appliance requires non-combustible floor protection as outlined in this manual (see *Floor Protection* on page 5 for additional information).
4. Minimum ceiling height must be 7 feet (213 cm) (measured from base of appliance to ceiling).
5. **DO NOT CONNECT THIS UNIT TO A CHIMNEY FLUE CONNECTED TO ANOTHER APPLIANCE.**
6. Do not connect this appliance to air ducts or any air distribution system.
7. **PREVENT CREOSOTE FIRE:** Inspect and clean chimney frequently. Under certain conditions of use, creosote buildup may occur rapidly. Inspect chimney connector and chimney twice monthly and clean if necessary. Using green or inadequately seasoned wood can greatly increase creosote buildup. Use dry wood to minimize creosote buildup.
8. **USE SOLID WOOD FUEL ONLY:** This appliance is approved for burning dry seasoned natural wood only. **CAUTION: BURN UNTREATED WOOD ONLY. OTHER MATERIALS SUCH AS WOOD PRESERVATIVES, METAL FOILS, COAL, PLASTIC, GARBAGE, SULFUR OR OIL MAY DAMAGE THE CATALYST. DO NOT BURN GARBAGE OR FLAMMABLE FLUIDS SUCH AS GASOLINE, NAPHTHA OR ENGINE OIL.**
9. Never use gasoline, gasoline-type lantern fuel, kerosene, charcoal lighter fluid, or similar liquids to start or "freshen up" a fire in this heater. Keep all such liquids well away from the heater while it is in use.
10. **DO NOT OVERFIRE:** If heater or chimney connector glows, you are overfiring. Overfiring this appliance could cause a house fire. Overfiring is a condition where the appliance is operated at temperatures above its design capabilities (see *Overfiring*, on page 23). Overfiring can be caused by improper installation, improper operation, lack of maintenance or improper fuel usage. Damage caused from overfiring is NOT covered under the manufacturers limited warranty. (see *Care and Operation*, pages 14 to 17).
11. **NEVER LEAVE AN UNATTENDED STOVE BURNING ON HIGH.** Operation of the stove with the primary air control at its highest burn rate setting for extended periods can cause dangerous overfiring conditions. The primary air control should only be positioned at the highest setting during start-up procedures and for short durations. When leaving the stove unattended ensure that the primary air control is set to the low or medium low range.
12. Use a metal container with a tight fitting lid to dispose of ashes.
13. **IN THE EVENT OF A COMPONENT FAILURE, USE ONLY COMPONENTS PROVIDED BY THE MANUFACTURER AS REPLACEMENT PARTS.**
14. Burning any kind of fuel uses oxygen from the dwelling. Be sure that you allow an adequate source of fresh air into the room where the stove is operating (see *Ventilation*, page 11 and *Outside Air*, page 8).
15. **CAUTION: HOT WHILE IN OPERATION.** An appliance hot enough to warm your home can severely burn anyone touching it. Keep children, clothing and furniture away. Contact may cause skin burns. Do not let children touch the appliance. Train them to stay a safe distance from the unit.
16. Build fires directly upon the brick hearth inside the stove. Do not use grates, irons or any other method to elevate the fire.
17. **SAVE THESE INSTRUCTIONS.**
18. See the listing label located on the back of stove (or see Safety/Listing Label on page 29).

TABLE OF CONTENTS

Important Warnings	2
Testing/Listing, EPA, Using this Manual.....	3
Planning Your Installation	4-7
Manufactured (Mobile) Home Requirements	8
Installation	8-13
Care and Operation	14-17
Recommended Fuel	17-18
Maintenance	18-20
Troubleshooting	21-23
Specifications	24
Replacement Parts List.....	25-27
Optional Accessories	28
Safety/Listing Label.....	29
EPA Label.....	30
Ownership Records	31

TESTING/LISTING

Model 1003C has been tested to UL Standard 1482 and ULC-S627 by OMNI-Test Laboratories Inc.; Beaverton, Oregon; Report number #030-S-02-2.

EPA CERTIFICATION

This stove has been tested to rigorous emissions standard, and has been certified by the Environmental Protection Agency.

USING THIS MANUAL

Please read and carefully follow all of the instructions found in this manual. Please pay special attention to the safety instructions provided in this manual. The Homeowner's Care and Operation Instructions included here will assure you have many years of dependable and enjoyable service from your appliance.

CONGRATULATIONS ON THE PURCHASE OF YOUR NEW WOODSTOVE MANUFACTURED BY LENNOX HEARTH PRODUCTS.

When you purchased your new woodstove, you joined the ranks of thousands of concerned individuals whose answer to their home heating needs reflects their concern for aesthetics, efficiency and our environment. We extend our continued support to help you achieve the maximum benefit and enjoyment available from your new wood stove.

It is our goal at Lennox Hearth Products to provide you, our valued customer, with an appliance that will ensure you years of trouble free warmth and pleasure.

Thank you for selecting a Lennox Hearth Products stove as the answer to your home heating needs.

Sincerely,
All of us at Lennox Hearth Products

PACKAGING LIST

This appliance is packaged with an accessory package, which contains the following:

- One - Installation and operation instructions manual.
- One - Warranty.
- One - Catalytic combustor temperature probe and sleeve.
- One - Damper Hook

PLANNING YOUR INSTALLATION

QUESTIONS TO ASK LOCAL BUILDING OFFICIAL

A correct installation is critical and imperative for reducing fire hazards and perilous conditions that can arise when wood burning appliances are improperly installed. The installer must follow all of the manufacturers' instructions.

The installation of a wood burning appliance must conform to local codes and applicable state and federal requirements. Familiarity with these requirements before installation is essential. Important considerations to discuss with local building officials include:

1. Applicable codes (i.e. Uniform Mechanical Code, State or Regional Codes.)?

Electrical codes: Optional Blower Assemblies have a flexible electrical cord that must be electrically grounded per local codes or per electrical codes:

In USA, NEC, ANSI/NFPA 70-2002.
In Canada, CSA C22.1

WARNING: ELECTRICAL GROUNDING INSTRUCTIONS: THIS APPLIANCE IS EQUIPPED WITH A THREE-PRONG (GROUNDING) PLUG FOR YOUR PROTECTION AGAINST SHOCK HAZARD AND SHOULD BE PLUGGED DIRECTLY INTO A PROPERLY GROUNDED THREE-PRONG RECEPTACLE. DO NOT CUT OR REMOVE THE GROUNDING PRONG FROM THIS PLUG. DO NOT ROUTE POWER CORD UNDER OR IN FRONT OF APPLIANCE.

2. Local amendments?
3. Is a permit required - cost?
(You may wish to contact your insurance company to ask if they require this).
4. Is outside combustion air required?
5. Rooms where the installation is not allowed?

SMOKE DETECTORS

Since there are always several potential sources of fire in any home, we recommend installing smoke detectors. If possible, install the smoke detector in a hallway adjacent to the room (to reduce the possibility of occasional false activation from the heat produced by the stove). If your local code requires a smoke detector be installed within the same room, you must follow the requirements of your local code. Check with your local building department for requirements in your area.

SELECTING A LOCATION

The design of your home and where you place your stove will determine its value as a source of heat. A wood stove depends primarily on air circulation (convection) to disperse its heat, and therefore, a central location is often best. There are other practical considerations, which must be considered before a final selection of locations is made:

- ◆ Existing Chimneys
- ◆ Wood Storage
- ◆ Aesthetic Considerations
- ◆ Roof Design (Rafter Locations & Roof Pitch)
- ◆ Room Traffic
- ◆ Proximity to Combustibles
- ◆ Electrical Wiring

The installation of this stove will require some research. Once your options are determined, consult with your local building department who will be able to give you the necessary installation requirements for your area (Is a building permit required, rooms where installation may not be allowed etc.).

WARNING: CHECK ALL LOCAL BUILDING AND SAFETY CODES BEFORE INSTALLATION. THE INSTALLATION INSTRUCTIONS AND APPROPRIATE CODE REQUIREMENTS MUST BE FOLLOWED EXACTLY AND WITHOUT COMPROMISE. ALTERATIONS TO THE STOVE ARE NOT ALLOWED. DO NOT CONNECT THE STOVE TO A CHIMNEY SYSTEM SERVING ANOTHER STOVE, APPLIANCE, OR ANY AIR DISTRIBUTION DUCT. FAILURE TO FOLLOW THESE INSTRUCTIONS WILL VOID THE MANUFACTURERS WARRANTY.

If you plan to vent your stove into an existing masonry chimney, have the chimney inspected by a local fire marshal or qualified installer. Remember that a stove's performance is heavily influenced by the chimney and its location on the roof. An oversized flue may not provide effective draw, and a flue liner may be required (see *Draft Requirements*, page 11). Consult your dealer or qualified installer before final selection is made.

This stove requires pre-installation work to be completed before installation can take place. This may include modification for flue and chimney.

NOTE – This appliance IS approved for installation into a Manufactured (Mobile) Home in Canada and the USA.

PLANNING YOUR INSTALLATION

FLOOR PROTECTION

This appliance requires non-combustible floor protection for ember protection. If the floor protection is to be stone, tile, brick, etc., it must be mortared or grouted to form a continuous non-combustible surface. If a chimney connector extends horizontally over the floor, protection must cover the floor under the connector and at least 2" (51 mm) to either side.

The floor protection must extend completely beneath the stove and to the front, sides, and rear as indicated:

USA REQUIREMENTS

- 16" (406 mm) min. to the front of the fuel door glass
- 8" (203 mm) min. beyond the sides of the fuel door opening
- 0" (0 mm) min. to the back of the stove body

CANADA REQUIREMENTS

- 18" (457 mm) min. to the front of the fuel door glass
- 8" (203 mm) min. beyond the sides of the stove body
- 8" (203 mm) min. to the back of the stove body

STANDARD PARALLEL HEARTH PAD SHOWN

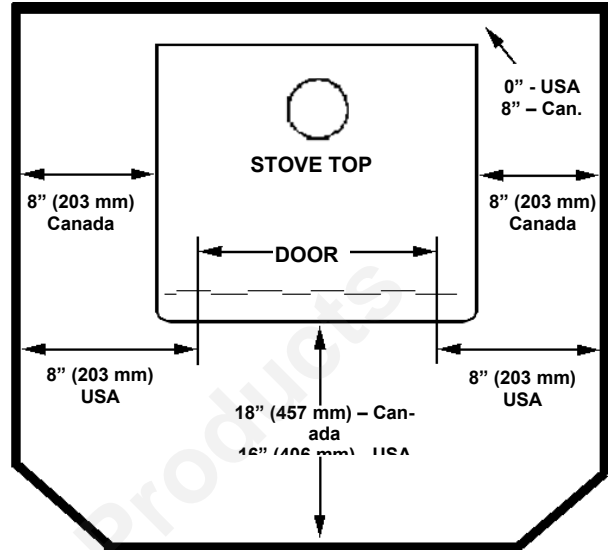

PLANNING YOUR INSTALLATION

COMBUSTIBLE WALL CLEARANCES

WARNING: IT IS VERY IMPORTANT THAT YOU OBSERVE THE MINIMUM CLEARANCES.

There are listed clearances for your stove which were determined in a Laboratory test using various "classes" of stove pipe or chimney. Minimums are first established for the stove itself and increased based on how much heat is transferred by each class of pipe.

NOTE: Manufactured (mobile) home installations require the use of a Type L-Vent Chimney connector only. Use of a single wall flue pipe connection is not permitted.

Manufactured (Mobile) Home Standard and Residential Reduced - Using 6" (152 mm) diameter Type L-Vent connector pipe (to the top of the stove) with listed factory-built 103HT chimney suitable for use with solid fuels or a code approved masonry chimney. Approved brands of factory built chimney are Dura-Vent, Security, Jake Evans and Metal Bestos.

MANUFACTURED (MOBILE) HOME INSTALLATIONS MUST BE EQUIPPED WITH A RAIN CAP AND SPARK ARRESTOR.

Clearances (inches / millimeters)

A. 14 / 356	C. 17 / 432	E. 16 / 406
B. 25 / 635	D. 9 / 229	F. 8 / 203

Residential Standard (not approved for manufactured [mobile] homes) Using 6" (152 mm) diameter, single wall connector pipe with listed factory-built to the top of the stove.

Clearances (inches / millimeters)

A. 22 / 559	C. 25 / 635	E. 16 / 406
B. 25.5 / 648	D. 16 / 406	F. 15 / 381

Residential Note: Approved for 6" (152 mm) diameter, single wall, minimum 24 MSG black or blued steel connector pipe with listed factory-built 103HT chimney suitable for use with solid fuels or a code approved masonry chimney.

Manufactured (Mobile) Home Reduced and Residential Reduced Using 6" (152 mm) diameter Type L-Vent connector pipe (to the top of the stove) with listed factory-built 103HT chimney suitable for use with solid fuels or a code approved masonry chimney. Approved brands of factory built chimney are Dura-Vent, Security, Jake Evans and Metal Bestos. MANUFACTURED (MOBILE) HOME INSTALLATIONS MUST BE EQUIPPED WITH A RAIN CAP AND SPARK ARRESTOR. Alcove size: 84" (213 cm) minimum height, 56" (143 cm) minimum width, and 24" (610 mm) maximum depth.

Clearances (inches / millimeters)

A. 11 / 280	C. 14.5 / 369	E. 16 / 406
B. 25.5 / 648	D. 5.5 / 140	F. 5.5 / 140

Vent Height (all installations) - The pipe should extend 12 feet above the stove top, as a minimum, to achieve a stable draft.

Corner Installation

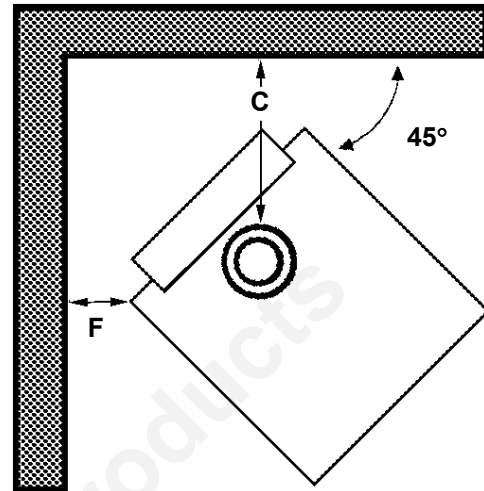

Parallel Installation

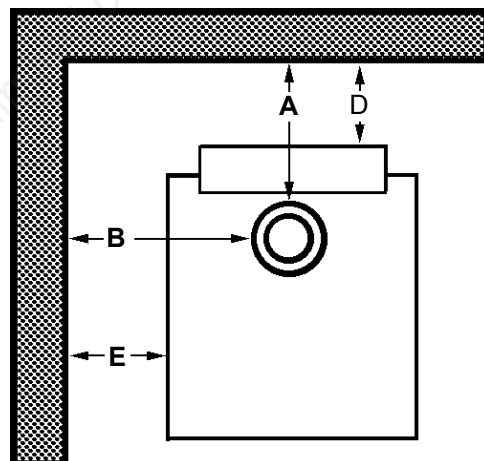

PLANNING YOUR INSTALLATION

ALCOVE CLEARANCES

NOTE: " = inches, mm = millimeter, cm = centimeter

Alcoves must have minimum dimensions of 84" (214 cm) height, 56" (142 cm) width and 24" (610 mm) maximum depth.

Require pipe: Type L Vent pipe to the top of the stove. Manufactured (mobile) home installations must be equipped with a rain cap and spark arrestor and must use a pipe shield extending a minimum of 24" (610 mm) above the stove (resting on stove) is mandatory for the installation of this appliance into a combustible alcove.

Alcove Dimension Requirements

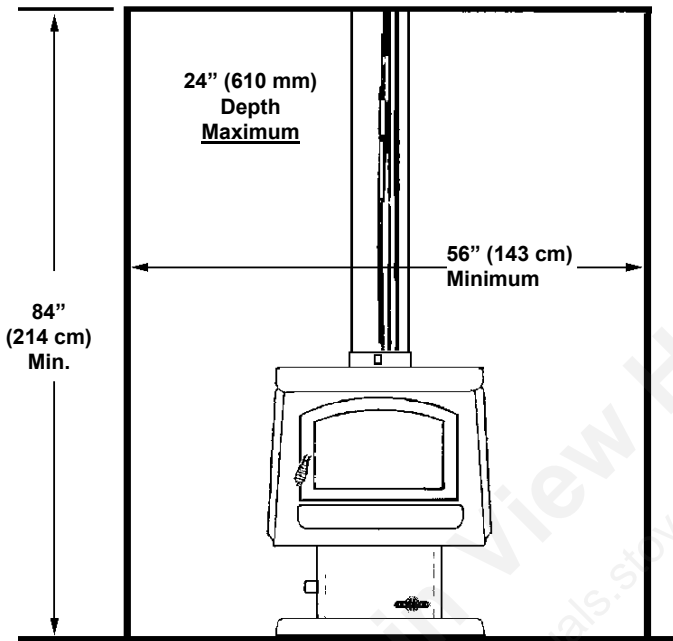

Alcove Top View / Stove Clearances

ALCOVE CLEARANCES:

Back wall to pipe O.D.	11" / 280 mm
Side wall to pipe O.D.	25.5" / 648 mm
Back wall to stove	5.5" / 140 mm
Side wall to stove	16" / 407 mm

Alcove - Top View

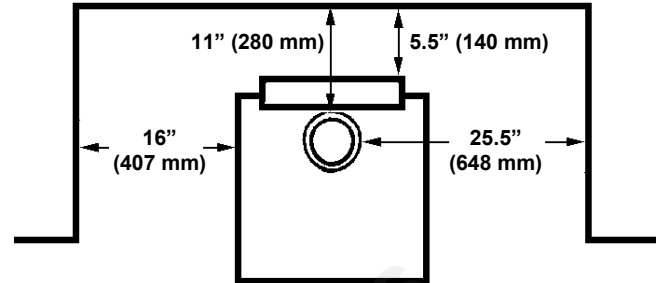

* **NOTE:** Alcove dimensions cannot be reduced by the use of non-combustible materials such as brick, stone, etc. Alcove dimensions listed are minimum dimensions and are not measurements for building an Alcove. You will need to consider these clearances, as well as other dimensional requirements before you build the alcove and install this appliance.

REDUCED MASONRY STRUCTURE CLEARANCE (ALCOVE)

Your stove can be installed in a masonry structure with reduced clearances if the structure was built to National Building Code for fireplaces and chimneys (UBC 37).

The firebox of the masonry structure must be of adequate size to allow a minimum of 6" (152.4 mm) clearance to the sides and top of the stove and 2" (50.8 mm) clearance to the rear. All stove models must be installed on their original listed legs or base unless otherwise specified by OMNI Testing Laboratory.

The minimum venting requirement is a listed chimney liner that extends from the flue collar of the stove to the first tile liner of the chimney where it is sealed. All joints and connections must be made airtight to prevent leaking and downdrafts.

PROTECTED WALL CLEARANCE

Some local codes will allow reduced clearances when the stove is installed adjacent to a protected wall system. Your local building official must approve the variance. Normally, the protected wall system is defined as a non-combustible material with a minimum of 1" (25.4 mm) air space behind. Check your local building codes or with a qualified installer (Ref. NFPA 211).

INSTALLATION

AIR INTAKE COVER

The pedestal is equipped with an air intake cover (located at the top front of the pedestal). The air intake cover should be adjusted to the open position if outside combustion air is NOT provided. If outside combustion air is provided, adjust to the closed position (see illustration to the right).

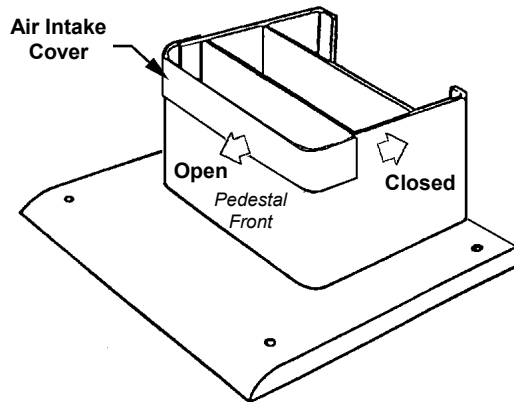

OUTSIDE AIR

In all manufactured (mobile) homes and in many site built residences (subject to local code), a stove may be required to use outside air for combustion. A 5 1/4" (133 mm) square outside air floor duct is available through your dealer.

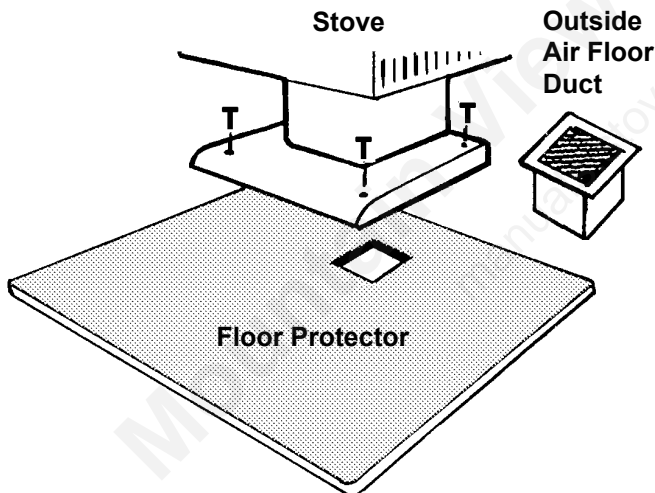

This stove can take in outside air directly through the base. This type installation requires a hole through the floor protector and the use of outside air floor duct (catalog # 14M67) to penetrate into the air space below the home. When outside air is hooked up, the Air Intake Cover must be adjusted to the closed position (see *Air Intake Cover* section on this page).

NOTE: Because the base sits 1" (25.4 mm) off the floor, the outside air floor duct can be positioned along the front to rear center line under the pedestal, but as close to the opening in the base as location permits. The air duct opening must be protected from any possible obstruction including loose floor insulation.

MANUFACTURED (MOBILE) HOME REQUIREMENTS

This stove is certified as a Room Heater, Solid Fuel Type and may be used in Manufactured Housing providing the following requirements are followed:

- An outside air inlet must be provided for combustion and be unrestricted while unit is in use.
- **WARNING: DO NOT INSTALL IN SLEEPING ROOM.**
- Regulations require that the appliance must be secured to the floor and grounded to the chassis. See *Securing the Stove to the Floor (and) Grounding Stove*.
- Required venting is 6" (152 mm) diameter Type L-Vent connector pipe with listed factory-built 103HT chimney suitable for use with solid fuels or a code approved masonry chimney. Approved brands of factory built chimney are listed in this manual. A rain cap and spark arrester is required (see *Clearances*, pages 6 & 7).
- **CAUTION: THE STRUCTURAL INTEGRITY OF THE MOBILE HOME FLOOR, WALL, AND CEILING/ROOF MUST BE MAINTAINED.**
- The chimney must provide for a section joint so that any parts extending above 13' 6" (411 cm) from ground level can be removed for transportation of the mobile dwelling.

INSTALLATION

SECURING THE STOVE TO THE FLOOR

Manufactured (Mobile) Homes Only

Once the outside air floor duct is in position, replace the floor protector. Make sure that the floor protector's hole is aligned with the outside air opening. Next position and align the stove on the hearth pad. Manufactured (mobile) home installations require that the stove be secured to the floor. This ensures that the stove will not shift when the manufactured (mobile) home is moved. To do this, mark where the holes are to be drilled using a marking instrument long enough and small enough to fit through the (4) four holes in the stove base. Mark holes, then remove the stove. Drill the (4) four holes, with a 1/4" (7 mm) drill bit. Drill down through the floor protector and the manufactured (mobile) home floor. Use 1/4" (7 mm) lag bolts and secure to the manufactured (mobile) home floor.

NOTE: If the composition of the manufactured (mobile) home floor is of light particleboard construction, you will be required to secure the stove with regular hex head bolts and nuts. This will ensure that the bolts will not rip out of the floor when the manufactured (mobile) home is being moved.

GROUNDING STOVE

Manufactured (Mobile) Homes Only

Regulations require that all stoves installed in manufactured (mobile) homes must be grounded. To do this simply attach a piece of No. 8 copper wire, at least 18" (457 mm) in length from the stove to the chassis of the manufactured (mobile) home.

INSTALLING CATALYTIC TEMPERATURE PROBE

Locate the temperature probe with sleeve in the literature packet. Insert sleeve, then temperature probe into the 1/4" (7 mm) diameter hole on the stove top.

REMOVE ASH DRAWER CLIP

The ash drawer is secured for shipping with a small retaining screw at the top of drawer. Remove and discard this screw.

TYPES OF CHIMNEYS

The chimney is a vital part of your stove installation. A properly built masonry chimney or a properly installed factory built chimney will assure a consistent draft under a variety of weather conditions (a smoking stove is usually caused by a chimney problem). The stove flue size is 6" (152 mm) diameter, which is approximately 28 square inches (712 square millimeters) minimum. The maximum flue size should be no more than (3)-three times the cross sectional area of the size of the stove flue collar. In this case, that would be no larger than a 10" (254 mm) diameter stack, or approximately 85 square inches (216 square centimeters) maximum.

All chimneys must be installed as specified by local building codes and according to the chimney manufacturer instructions (in the case of a factory built chimney). See the chimney manufacturer instructions for exact specifications. Factory built chimneys must comply with UL 103HT or ULC S629.

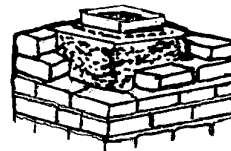

Tile-lined
Masonry
Chimney

Factory
Built
Chimney



ACCEPTABLE CONNECTOR PIPE FOR INSTALLATIONS

For Standard Residential Clearances: Six 6 inch (152 mm) minimum, single wall, 25 gage minimum thickness, stove pipe is acceptable. Three (3) pre-drilled holes are provided in the flue collar for fastening the pipe securely to the stove. Use sheet metal screws to do this. Additional sections of single wall pipe should be fastened together with at least three (3) sheet metal screws each section. When connecting to the factory built ceiling support package, use the manufacturer's transition piece, usually called a dripless connector, to join single wall pipe to their factory built chimney section.

Minimum Flue Size: The required minimum diameter and area required for the flue size is (respectively) 6 inches / 152 mm diameter, which is approximately 28 square inches / 711 square mm. The maximum flue size should be no more than (3) three times the cross sectional area of the size of the 6 inches / 152 mm diameter flue collar. In this case, that would be no larger than a 10 inch (254 mm) diameter (area = approx. 85 sq. inches [216 sq. cm]).

Connection To A Factory Built Chimney: This space heater is to be connected to a factory-built chimney conforming to CAN / ULC – S629, Standard for 650°C Factory-Built Chimneys.

For Reduced Residential Clearances: Type L and listed double wall connector pipe is acceptable. Install any factory built brand of pipe according to the manufacturer's instructions.

INSTALLATION

CHIMNEY INSPECTION

Existing chimneys must be inspected before installing your stove. Consult your local building department for chimney code requirements. A masonry chimney must have a code approved liner. This liner must not have broken or missing pieces. Some non-code masonry chimneys may be brought up to code by being relined. (Consult your dealer or qualified chimney sweep). Factory built chimneys should also be inspected, first for creosote deposits (which should be removed), and then for integrity of the stainless steel liner. Look for obvious bulges in the lining, which may indicate the need to replace that section (use a bright flashlight).

Also, inspect the attic to see that the chimney has proper clearance to combustible framing members. For interior masonry chimneys and most factory-built chimneys, this must be a 2" (51 mm) air space clearance, which must not be filled with insulation or any other material. An exterior masonry chimney must have a 1" (25.4 mm) air space clearance.

Vapor Barrier At Chimney Penetration

Install all venting components per the Vent Manufacturers installation instructions. Ensure that there is an effective vapor barrier at the location where the chimney penetrates to the exterior of the structure. This can be accomplished by applying a non-hardening waterproof sealant to the following components:

- Around the chimney at the point where the storm collar will meet the chimney just above the Flashing.
- Along the vertical seam of the chimney pipe, where it is exposed to the weather.
- On each nail head on the flashing.
- Around the chimney at the point where the storm collar will meet the chimney just above the flashing.

Notes:

- On a flat or tarred and graveled roof, nail and seal the flat roof flashing to the roof on all sides with roofing compound.
- Do not put screws through the flashing into the chimney pipe.

CHIMNEY HEIGHT REQUIREMENTS

The chimney must extend 3 feet (914 mm) above the level of roof penetration and a minimum of 2 feet (610 mm) higher than any roof surface within 10 feet (305 cm) (see below). Check with your local building officials for any additional requirements for your area.

Due to prevailing winds, local terrain, adjacent tall trees, a hill, or ravine near the home, or adjacent structures, additional chimney height or a special chimney cap may be required to ensure optimum performance.

The 2' by 10' Rule for Vent Termination

The top of the flue must be 2' (610 mm) higher than any part of the roof within 10' (305 cm) horizontal and a minimum of 3' (915 mm) higher than the highest point of roof penetration.

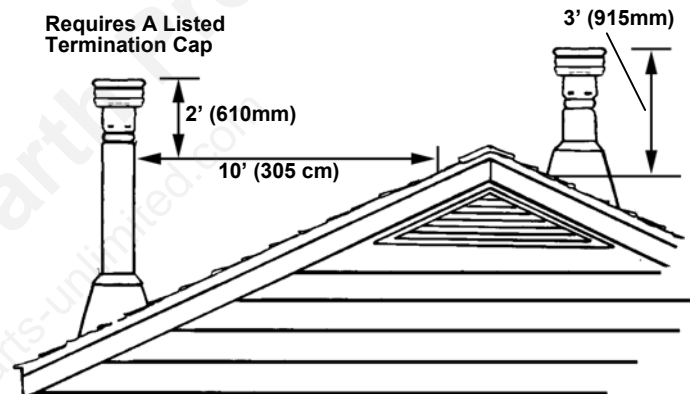

For Manufactured (Mobile) Homes Only: Portions of the chimney and termination that exceed an elevation of 13½ feet above ground level may be designed to be removed for transporting the manufactured (mobile) home.

INSTALLATION

DRAFT REQUIREMENTS

The appliance is merely one component of a larger system. The other equally important component is the venting system which is necessary for achieving the required flow of combustion air to the fire chamber and for safely removing unwanted combustion byproducts from the appliance. If the venting system's design does not promote these ends, the system may not function properly. Poorly functioning venting systems may create performance problems (i.e. smoking stove, poor heat output, fire goes out, window blackens, increased creosote buildup, etc.) as well as be a safety hazard. Some factors that may lead to performance problems are as follows:

- Oversized or undersized chimney.
- Excessive offsets in venting.
- Insufficient vertical height of chimney.
- Insufficient chimney termination height in relationship to roof.
- Insufficient ventilation.
- Lack of maintenance.
- Improper operation.
- Burning improper fuel (unit is approved for use with natural dry well-seasoned wood only).
- Down drafts in the chimney (may need a special wind cap).

To ensure that the venting system is functioning properly a draft test should be performed (see *Draft Test Procedure* on this page).

American National Standards Institute ANSI/NFPA 211-92: A chimney or vent shall be so designed and constructed to develop a flow sufficient to completely remove all flue and vent gases to the outside atmosphere. The venting system shall satisfy the draft requirements of the connected appliance in accordance with the manufacturer instructions.

DRAFT TEST PROCEDURE

After this appliance is installed a draft test should be performed to ensure proper draft. A qualified technician should perform the draft test procedure as follows:

- 1) Close all windows and doors in the dwelling.
- 2) Turn on or operate all appliances which remove air from the home (such as a furnace, heat pump, air conditioner, clothes dryer, exhaust fans, fireplaces, and other fuel burning appliances).
- 3) Drill a hole in the vent pipe per the draft gauge manufacturers instructions (to create a draft test port). Note: Hole location should be a minimum of 1 foot above flue outlet collar.

- 4) Start a fire (See *How To Start And Maintain A Fire* on page 16).
- 5) After the fire is well established (20-25 minutes) and burning at a low setting, perform the draft test per the gauge manufacturer instructions. The draft gauge should read between .05 and .07" W.C. (inches water column). Excessive draft (above .07 W.C.I.) can result in too much combustion air to be pulled into the firebox, this will produce hotter burns and could result in overfiring. Too little draft (below .05" W.C.) will not allow enough combustion air delivery to maintain a fire well or cause performance problems such as smoking (this may result in improper operation of appliance, i.e. will not maintain fire well unless ash drawer or fuel door is left open).
- 6) Install a screw to seal the draft test port in the vent pipe. If the draft test reading was not within the required range, correct the installation and repeat this procedure.

VENTILATION REQUIREMENTS / PROVIDE ADEQUATE AIR FOR COMBUSTION

THE FRESH AIR REQUIREMENTS OF THIS APPLIANCE MUST BE MET WITHIN THE SPACE WHERE IT WILL BE INSTALLED. VENTILATION IS ESSENTIAL WHEN USING A SOLID FUEL BURNING HEATER.

In well insulated and weather tight homes, it may be difficult to establish a good draft up the chimney (caused by a shortage of air in the home). The lack of air is caused by many common household appliances which exhaust air from the home (such as a furnace, heat pump, air conditioner, clothes dryer, exhaust fans, fireplaces, and other fuel burning appliances). Also, the combustion process of this heater uses oxygen from inside the dwelling. If the available fresh air delivery in the dwelling is insufficient to support the demands of these appliances, problems can result (i.e. excessive negative pressure can develop in the dwelling which will affect the rate at which this appliance can draft thus resulting in performance problems; See *Draft Requirements* on this page). To correct this problem it may help to open a window (preferably on the windward side of the house) or install a vent to provide make-up air into the dwelling.

INSTALLATION

See Pipe Manufacturers Instructions For Installation Requirements Of Venting Components And Vent Clearances.

RESIDENTIAL STANDARD

Using 6" (152 mm) Diameter Single Wall Connector Pipe. Not Approved For Manufactured (Mobile) Homes.

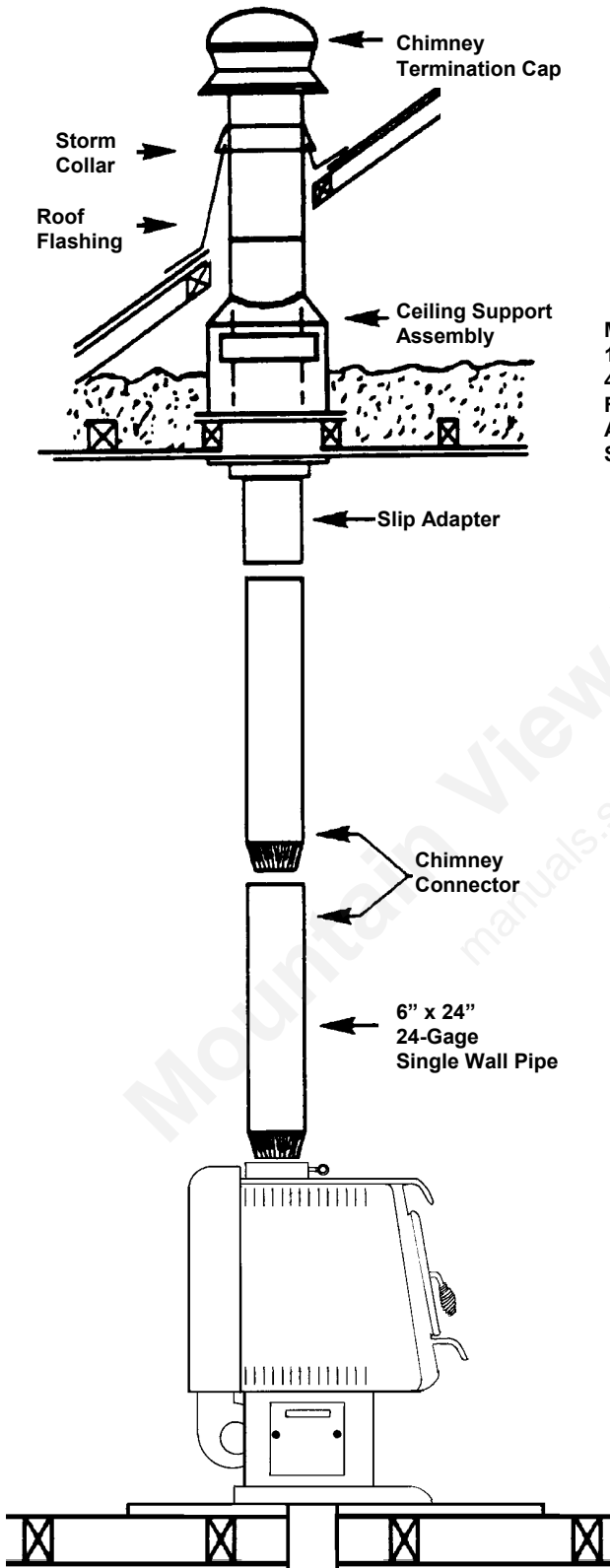

MANUFACTURED (MOBILE) HOME STANDARD

Using 6" (152 mm) Diameter Type L-Vent Connector Pipe

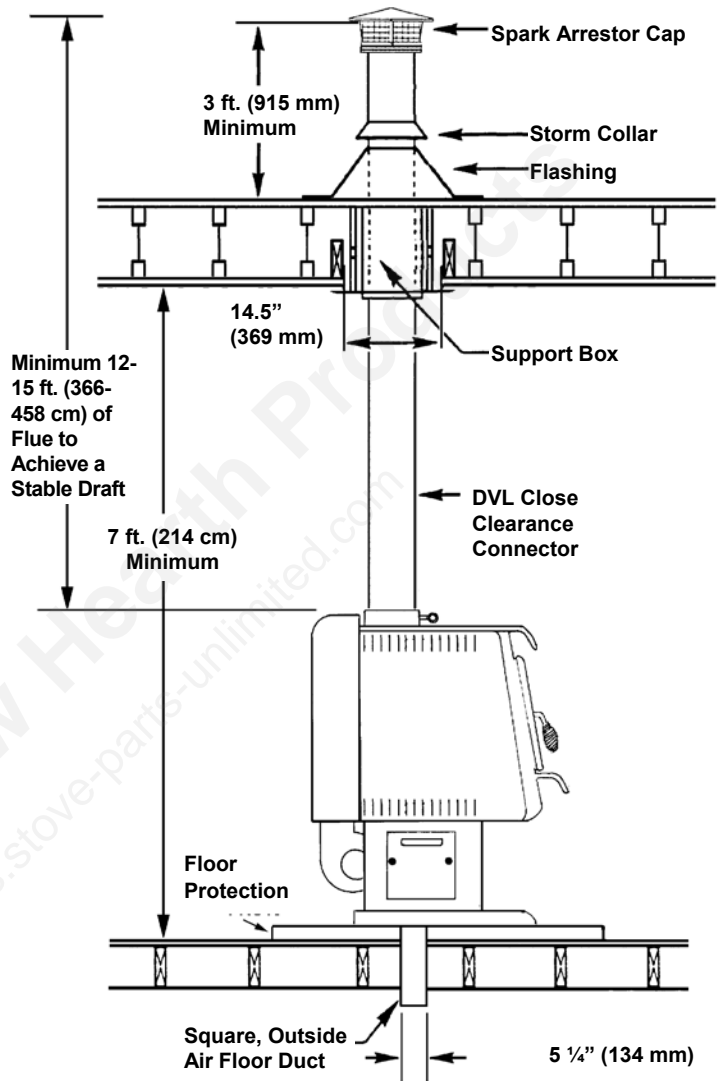

IMPORTANT NOTES:

- **Minimize the use of elbows (30°, 45° or 90°)** - Offsets in the venting system are very restrictive and will inhibit the draft (i.e. You will lose approximately 5 feet of effective draft for every 90 degrees of direction change). This appliance requires 12 to 15 feet of effective draft for optimum performance (see *Draft Requirements* on page 11).
- **First section of pipe must be vertical** - Use as much straight vertical pipe directly above the appliance as possible before using an elbow (a 2' to 3' initial vertical rise is suggested).

INSTALLATION - Combustible Wall Chimney Connector Pass-Throughs

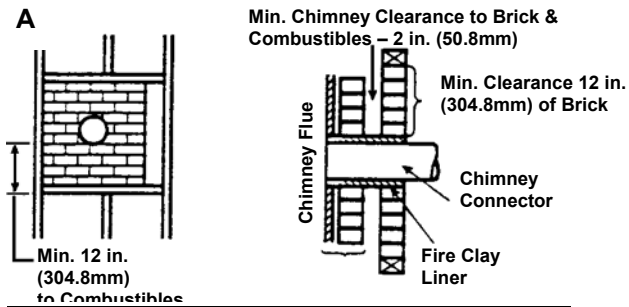

Method A. 12" (304.8 mm) Clearance to Combustible Wall Member: Using a minimum thickness 3.5" (89 mm) brick and a 5/8" (15.9 mm) minimum wall thickness clay liner, construct a wall pass-through. The clay liner must conform to ASTM C315 (Standard Specification for Clay Fire Linings) or its equivalent. Keep a minimum of 12" (304.8 mm) of brick masonry between the clay liner and wall combustibles. The clay liner shall run from the brick masonry outer surface to the inner surface of the chimney flue liner but not past the inner surface. Firmly grout or cement the clay liner in place to the chimney flue liner.

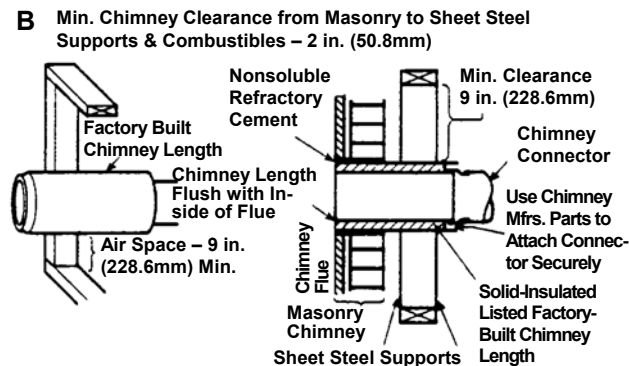

Method B. 9" (228.6 mm) Clearance to Combustible Wall Member: Using a 6" (152.4 mm) inside diameter, listed, factory-built Solid-Pak chimney section with insulation of 1" (25.4 mm) or more, build a wall pass-through with a minimum 9" (228.6 mm) air space between the outer wall of the chimney length and wall combustibles. Use sheet metal supports fastened securely to wall surfaces on all sides, to maintain the 9" (228.6 mm) air space. When fastening supports to chimney length, do not penetrate the chimney liner (the inside wall of the Solid-Pak chimney). The inner end of the Solid-Pak chimney section shall be flush with the inside of the masonry chimney flue, and sealed with a non-water soluble refractory cement. Use this cement to also seal to the brick masonry penetration.

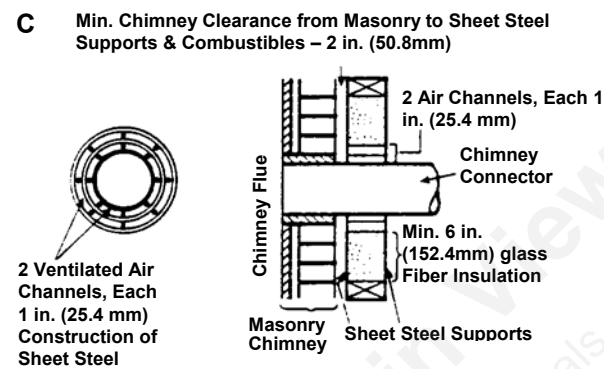

Method C. 6" (152.4 mm) Clearance to Combustible Wall Member: Starting with a minimum 24 gage (.024" [.61 mm]) 6" (152.4 mm) metal chimney connector, and a minimum 24 gage ventilated wall thimble which has two air channels of 1" (25.4 mm) each, construct a wall pass-through. There shall be a minimum 6" (152.4 mm) separation area containing fiberglass insulation, from the outer surface of the wall thimble to wall combustibles. Support the wall thimble, and cover its opening with a 24-gage minimum sheet metal support. Maintain the 6" (152.4 mm) space. There should also be a support sized to fit and hold the metal chimney connector. See that the supports are fastened securely to wall surfaces on all sides. Make sure fasteners used to secure the metal chimney connector do not penetrate chimney flue liner.

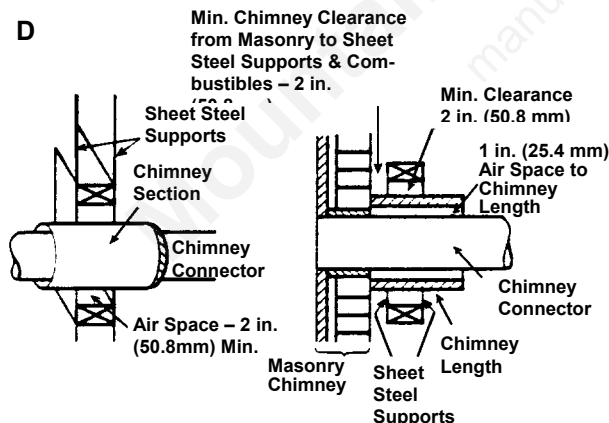

Method D. 2" (50.8 mm) Clearance to Combustible Wall Member: Start with a solid-pak listed factory built chimney section at least 12" (304 mm) long, with insulation of 1" (25.4 mm) or more, and an inside diameter of 8" (2 inches [51 mm] larger than the 6" [152.4 mm] chimney connector). Use this as a pass-through for a minimum 24-gage single wall steel chimney connector. Keep solid-pak section concentric with and spaced 1" (25.4 mm) off the chimney connector by way of sheet metal support plates at both ends of chimney section. Cover opening with and support chimney section on both sides with 24 gage minimum sheet metal supports. See that the supports are fastened securely to wall surfaces on all sides. Make sure fasteners used to secure chimney section do not penetrate chimney flue liner.

NOTES:

1. Connectors to a masonry chimney, excepting method B, shall extend in one continuous section through the wall pass-through system and the chimney wall, to but not past the inner flue liner face.
2. A chimney connector shall not pass through an attic or roof space, closet or similar concealed space, or a floor, or ceiling.
3. Where passage through a wall, or partition of combustible construction is desired, the installation shall conform to CAN/CSA-B365.

CARE AND OPERATION

ASH DRAWER

The large ash drawer located on the left side of the pedestal is designed to make cleaning easier by containing the ashes in a removable drawer.

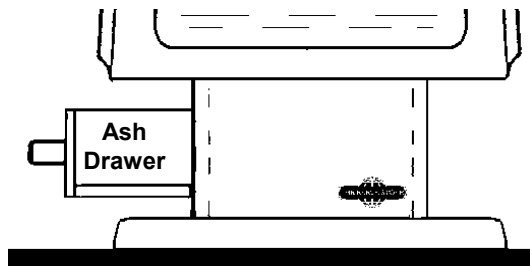

WARNING: DO NOT OPERATE THIS STOVE WITHOUT THE ASH DRAWER PROPERLY INSTALLED AND SECURED (SEALED), AS THIS WILL PRODUCE EXTREME TEMPERATURES, RESULTING IN OVERFIRING. THE ASH DRAWER GASKET PROVIDES AN IMPORTANT SEAL, AND MUST BE MAINTAINED (SEE MAINTENANCE REQUIREMENTS ON PAGE 19). OVERFIRING CAN RESULT IN DAMAGE TO THE APPLIANCE OR A HOUSE FIRE. OPERATION WITH THE ASH DRAWER OPEN OR AJAR, NULLIFIES THE SAFETY LISTING AND VOIDS THE WARRANTY.

CATALYTIC COMBUSTOR

How it works: From 5 to 30 percent of the chemical energy contained in every log escapes up the chimney when wood is burned in a conventional stove. The catalytic combustor is designed to make use of this energy, converting it into useful heat as it lessens chimney creosote build-up and air pollution. The catalytic combustor consists of a durable temperature resistant ceramic composition, which is extruded into a cellular, or honeycomb, configuration. After extrusion, this ceramic monolith is fired and then covered with a noble-metal catalyst. When wood smoke contacts this catalyst, chemical changes occur that causes the smoke to ignite at temperatures around 600° F. Normally, smoke will ignite and burn only at temperatures around 1000° F.

CATALYTIC BYPASS DAMPER CONTROL

The operating handle of your *Bypass Damper Control* is located on the front of the *Stove Flue Collar*. By moving the *Bypass Damper Control* the operator can route the exhaust either through the *Catalytic Combustor* (pushed in) or directly up the flue (pulled out). When starting a fire or refueling, the *bypass damper control handle* should be pulled out. Once the fire is established it should be pushed in.

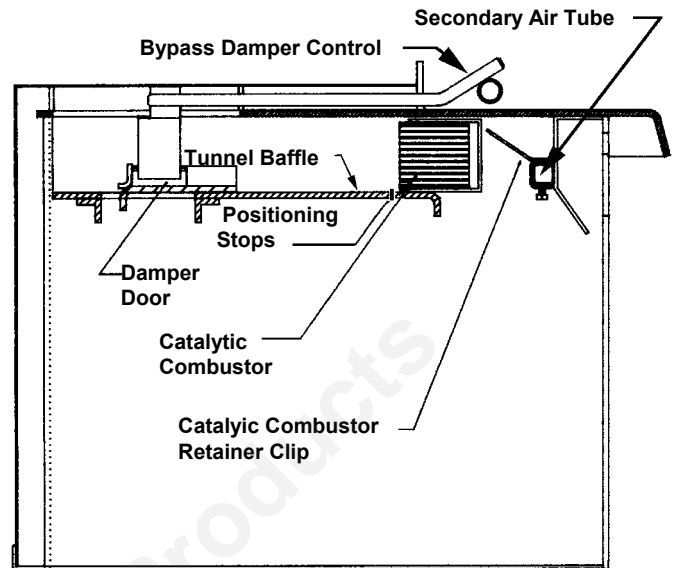

PRIMARY AIR CONTROL

The primary combustion air delivery is controlled by the Primary Air Control Assembly. The control handle is located on the lower right side (front) of the stove - see illustration below. The heat output can be controlled by sliding the handle to a higher or lower heat output setting. The fuel, the amount of heat and burn times desired, the type of installation are all variables that will affect the control setting. The same control settings in a variety of installations will produce different results. You will need to try different settings so you can learn how much heat to expect and how long the fire will burn.

Primary Air Control Handle

Slide the control to the left for a lower burn rate, to the right for a higher burn rate.

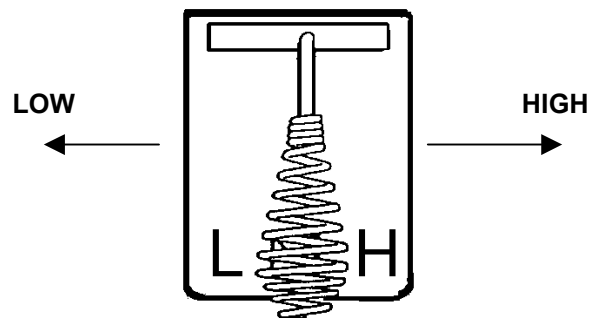

You will generally want to set the primary air control on low or medium. The stove is safe burning on any setting as long as combustibles are kept at the specified safe distances.

CARE AND OPERATION

FUEL DOOR

The gold or black door option is purchased separately, but is required. Install the door per instructions provided in kit (see page 28 for ordering information).

WARNING: DO NOT OPERATE THIS STOVE WITHOUT THE DOOR PROPERLY INSTALLED AND SECURED AS THIS WILL PRODUCE EXTREME TEMPERATURES (OVERFIRING). THE DOOR AND GLASS GASKETS PROVIDE IMPORTANT SEALS, AND MUST BE MAINTAINED (SEE MAINTENANCE REQUIREMENTS ON PAGE 19). OVERFIRING CAN RESULT IN DAMAGE TO THE APPLIANCE OR A HOUSE FIRE. OPERATION WITH THE DOOR OFF OR OPEN NULLIFIES THE SAFETY LISTING AND VOIDS THE WARRANTY.

Door Operation: The door handle assembly opens and securely latches the fuel door closed. To open the door, rotate the coil handle to the 9:00 position until door releases. To close and latch, hold the coil handle in the 9:00 position, close the door, then rotate the handle to the 6:00 position. See illustration below.

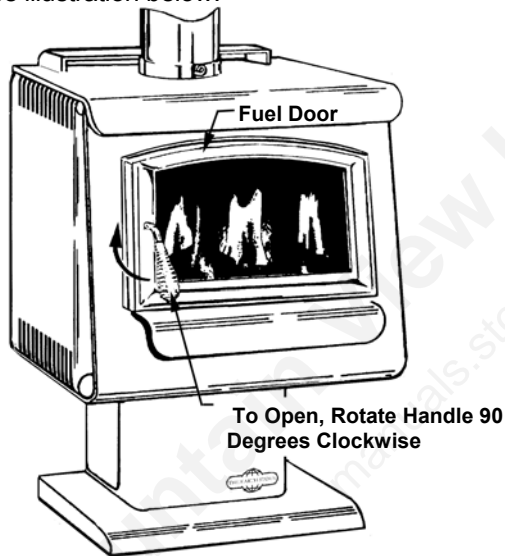

CAUTION: WHEN OPENING THE DOOR, DO NOT EXTEND IT BEYOND ITS NORMAL TRAVEL. OVEREXTENDING THE DOOR TO A FURTHER OPEN POSITION CAN PUT EXCESSIVE STRESS ON HINGE AREA OF DOOR AND HINGE PINS AND MAY RESULT IN BREAKAGE.

Gold Doors: Gold doors are plated with 24-karat industrial grade gold and will require curing to harden the gold. Once it is cured it will never tarnish. Prior to burning this appliance the doorframe should be cleaned thoroughly with a good window cleaning solution and a soft cloth. Do not use any metal polishes or abrasives to clean the gold surface. Any oils or fingerprints left on the gold could become permanent blemishes if the stove is burned prior to their removal. After the first few fires, the

gold will cure. The $\frac{3}{4}$ " (19 mm) door rope gasket is made of highly durable high temperature resistant material. It must be kept in good condition. Do not leave the stove burning with the door ajar or open. Leaving the door ajar or open while the stove is burning will cause excessive heat build up in the stove (overfiring) and could ignite surrounding combustibles as well as damage the stove (such damage is not covered by the manufacturer's warranty).

GLASS

The Glass is a super heat resistant ceramic that withstands continuous temperatures up to 1390° F. This temperature is well beyond the temperatures in which you operate your stove. If the glass ever becomes damaged in any way, replace it, using only 5 mm ceramic glass (part # G2000-7).

This appliance is designed to provide a flow of air over the inside of the glass, which along with high heat helps keep it clean. When operating the stove on low for extended periods of time, the glass may get dirty. A short, hot fire (15 - 20 minutes) will help clean off much of the normal buildup (see *Troubleshooting*, pages 21-23). A commercial glass cleaner designed for stoves is recommended for cleaning.

The glass should be cleaned thoroughly with glass cleaner and a soft cloth BEFORE the stove is burned.

USE CONTROL SETTINGS THAT WORK FOR YOU

The fuel, the amount of heat you want, the type of installation you have and how long you wish the fire to burn are all variables that will affect the control settings. The same control settings in a variety of installations will produce different results.

Familiarize yourself with your stove by trying different settings so you can learn how much heat to expect and how long the fire will burn. It may take a week or two to learn, but your patience will be rewarded by the warmth and pleasant satisfaction that only a wood fire can provide.

CARE AND OPERATION

BREAK-IN PERIOD

Your stove finish is a high temperature paint that requires time and temperature to completely cure. We recommend that you ventilate the house during the initial burns. The paint emits non-toxic odors during this process.

KEEP YOUR HOUSE WELL VENTILATED DURING THE CURING PROCESS TO PREVENT ACTIVATION OF YOUR HOME SMOKE DETECTOR.

The paint manufacturer recommends three burn cycles to cure the paint. The first two burns should be low heat, approximately 250° F., for 20 minutes each, using paper and light kindling.

After each 20-minute burn, allow the appliance to cool completely. The third burn should be at least medium high or about 450° F. for 45 - 60 minutes. The paint will become soft and emit non-toxic haze during these burns. Keep the area well ventilated.

As the paint cures it will become slightly lighter in color. Eventually the entire surface will become an even color. Once the paint has been softened and cooled two or three times, it will harden. Do not turn on a blower during the curing process. Do not place anything on the stove surface until the paint is completely cured. Do not attempt to repaint the stove until the paint is completely cured. If the surface later becomes stained or marred, it may be lightly sanded and touched up with spray paint from the same paint manufacturer (See *Small Area Paint Touch-Up*, page 18). Paint is available at your local authorized Lennox Hearth Products dealer. Never attempt to paint a hot stove.

CATALYTIC COMBUSTOR

During the start-up of a cold stove, a medium to high firing rate must be maintained for about 20 minutes. The high firing rate will ensure that the stove, the flue, the catalyst, and the fuel are all stabilized at proper operating temperatures. Even though it's possible to have temperatures in the stove reach 600° F. within two or three minutes after the fire is started, do not set the primary air control lever to the "LOW" position until approximately twenty minutes have passed. Setting the primary air control on "LOW" too early could result in either the fire or the catalytic combustor going out.

At the end of a burn cycle, it's possible that the hot embers remaining might not provide sufficient fuel value for the catalyst to retain its minimum operating temperature of 600° F. During the refueling, we recommend that the stove be refired for about 10 minutes with the bypass open to ensure a good draw is established and that the

catalyst reaches 600° F. The refiring will ensure sufficient temperatures and proper amounts of volatiles for the catalyst to operate properly.

When refueling a hot stove with the catalyst still operating, no refiring step is necessary. Just open the bypass, set the primary air control to high, open the door approximately 1/2" (1 cm), and wait for about thirty seconds. Load the fuel, close the door, close the bypass and set the primary air control to normal operation. Temperatures within the firebox should be hot enough to maintain the catalytic operation.

HOW TO START AND MAINTAIN A FIRE

1. Check to be sure the grate is in place and the ash drawer is closed.
2. Open the bypass damper control by pulling it toward you. In the "OPEN" position the draft air will bypass the catalytic combustor and make starting the fire easier.
3. Set the primary air control lever on "HIGH". The "HIGH" setting will maximize your primary combustion air.
4. Build a fire directly on the firebrick covering the bottom of the stove.
 - a. Place five or six loosely crumpled sheets of newspaper in the stove.
 - b. Add a small amount of dry kindling randomly on the top of the newspaper.
 - c. Place a few more loosely crumpled newspapers on top of the kindling and light the bottom paper first, then light the top paper. Once the kindling is ignited and burning on its own, close the fuel door. The upper fire should help preheat the chimney and create an effective draft while the lower fire ignites the kindling.
5. When the kindling is burning well, add increasingly larger pieces of wood until the fire is actively burning.
6. When the fire is well established, use the damper hook and close the bypass by pushing the control rod in (catalytic temperature probe should read 600°F, takes approximately 20 - 25 minutes to reach this temperature).
7. When the fire is well-established slide the air control lever for the desired heat output.

CARE AND OPERATION

REFUELING

To refuel the stove, open the bypass damper and move the primary air control to "HIGH." Let the fire "LIVEN UP" for about one minute. Open the fuel door about 1/2" (1 cm) and hold in this position about 30 seconds or until the stove is drafting well. Open the door and add wood. After refueling, reset the primary draft control to the desired position, and close the bypass when the catalytic temperature probe reaches operating temperatures of 600° F indicated on the temperature probe.

BYPASS DAMPER CONTROL

The operating handle of your bypass damper control is located on the front of the stove flue collar. By moving the bypass damper control, the operator can route the fire either through the catalytic combustor (pushed in) or directly up the flue (pulled out). When starting a fire or refueling, the bypass damper control must be pulled out. Once the fire is established, it must be pushed in.

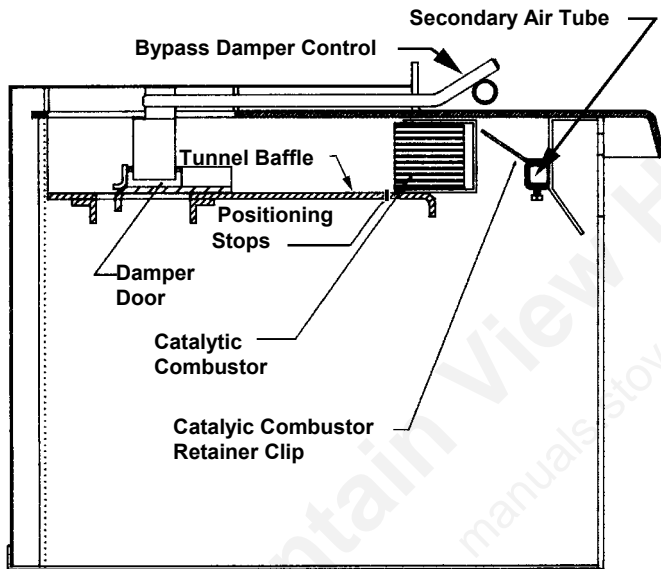

CATALYTIC TEMPERATURE PROBE

The catalytic temperature probe monitors the temperature of your catalytic combustor. Once you have established a fire and the catalytic temperature probe indicates the temperature of your catalytic combustor. When it reaches a temperature of 600 degrees (approximately 20 - 25 minutes), close the bypass damper control. Depending on the type and size of the fuel load as well as the length of time the stove has been burning, your catalytic combustor should operate –between 1000 to 1800 degrees.

When the optional blower is operating it will affect the temperature probe reading. Turn the blower off for an accurate reading.

FUEL

BURN RECOMMENDED FUEL

This appliance is approved for use with untreated natural dry wood only (see *Important Warnings*, page 2, #8). Burning materials other than natural wood will shorten the life of the catalytic combustor. Do not burn particle-board or pressed logs using bonding agents as they can produce conditions, which will deteriorate metal or damage the catalyst. Green or uncured wood does not work well as fuel, and can cause increased creosote buildups and plugging of the catalytic combustor. The value of green wood as a source of heat is limited. Do not overload or use kindling wood or mill ends for primary fuel as this may cause overfiring. Overfiring is a condition where excessive temperatures are reached, beyond the design capabilities of the stove. The damage that occurs from overfiring is not covered under the stove warranty.

WARNING: BURNING IMPROPER FUEL (I.E. CHARCOAL) CAN RESULT IN CARBON MONOXIDE POISONING WHICH MAY LEAD TO DEATH!

CARBON MONOXIDE POISONING – EARLY SIGNS OF CARBON MONOXIDE POISONING RESEMBLE THE FLU WITH HEADACHES, DIZZINESS, OR NAUSEA. IF YOU HAVE THESE SIGNS, GET FRESH AIR AT ONCE! HAVE THE HEATER INSPECTED BY A QUALIFIED SERVICE TECHNICIAN. SOME PEOPLE ARE MORE AFFECTED BY CARBON MONOXIDE THAN OTHERS. THESE INCLUDE PREGNANT WOMEN, PEOPLE WITH HEART OR LUNG DISEASE OR ANEMIA, THOSE UNDER THE INFLUENCE OF ALCOHOL, AND THOSE AT HIGH ALTITUDES.

WHY SEASONED WOOD?

The key to the success of a good fire that produces heat from a woodstove is the wood. It needs to be well-seasoned natural wood.

What does "Well-Seasoned" mean? When a tree is cut down, the wood is green, full of sap and moisture. This moisture content can exceed 80%, which must be reduced to less than 20%. Wood properly seasoned is then capable of generating the heat the stove was designed to provide.

Green wood does not burn easily. Attempting to burn green wood often results in a lot of smoke and very little fire. Time is the most important factor in seasoning wood. Ideally the moisture content should be reduced to 11-20%, although very few of us will be able to check that figure. There are several steps that should be taken to ensure that that you come close to these figures.

FUEL

SEASONING GUIDE

Softwoods – 6 months to 18 months

Hardwoods – 12 months to 24 months

Logs that are 5" (127 mm) diameter across or larger should be split in half, three pieces if over 8" (203 mm), and four pieces when over a foot (305 mm) across. If the tree was fell 2 to 4 years ago, it still needs to be cut, split, and seasoned for 6 to 24 months depending on the wood.

WOOD STORAGE

Wood to be seasoned should be stacked in an area open enough to ensure good air circulation on both sides – leaving adequate space between woodpiles to walk comfortable. Do not stack wood against a wall or building. It helps to elevate the woodpiles off the ground (two 2 x 4's running lengthwise beneath the woodpile works well). This allows air to flow under the bottom logs. Wood that is kept outdoors, either covered with a tarp, or not covered at all, will not burn well until it has been in an enclosed space for one to two months.

MAINTENANCE

FIREBRICK

The firebrick should be inspected periodically and replaced if damaged (crumbling or excessively cracked).

SMALL AREA PAINT TOUCH-UP

The stove body is painted with a quality high-temperature stove paint. Use only model TSPK-B Stove Paint, Catalog # 70K99. Do not touch-up your stove with any other paint.

Using one small piece of 320 grit sand paper and lightly sand the blemish so that the edges are "feathered" or smooth to the touch between the painted and bare surfaces. Do not let the sand paper gum up with paint, as this will cause scratches on the metal surface. If there are any scratches, use 600 grit sandpaper instead. Mask off surfaces you do not want painted. Paint lightly over the bare surface first as this will act as an undercoat. Then paint over a larger area in smooth even strokes to blend.

See *Break-In Period* on page 16 for information on curing the paint.

CLEANING BLOWER INTAKE

If an optional blower kit (catalog #14M22) is installed, the blower air intake requires cleaning at least once a year to remove lint, dust, etc. If there are pets in the dwelling, the intake should be cleaned at least twice a year.

MAINTENANCE

ASH REMOVAL AND DISPOSAL

CAUTION: MAKE SURE THAT THE FIRE IS OUT AND THE STOVE IS COLD BEFORE REMOVING ASHES! NEVER BURN YOUR STOVE WITH THE ASH DRAWER OPEN OR UNSECURED!

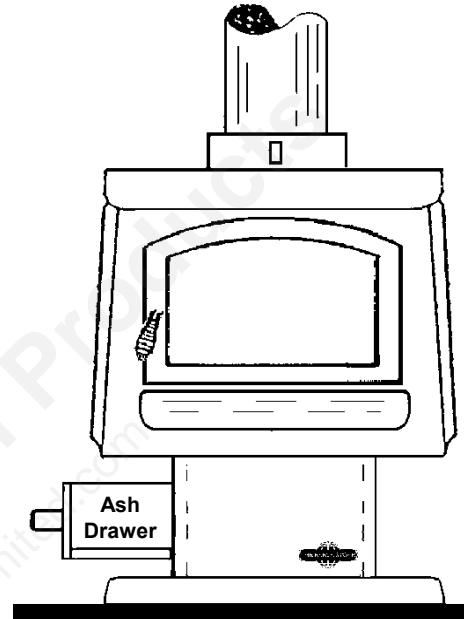

Ashes can hold live embers for several days, and must be disposed of with care.

Scrape ashes from the firebox through the grate into the ash drawer. After emptying, clean and replace the ash drawer and tighten the securing knobs.

NEVER place ashes in a cardboard box or any other combustible receptacle.

Proper Disposal of Ashes:

Ashes should be placed in a metal container with a tight fitting lid. The closed container of ashes should be placed on a noncombustible floor or on the ground, well away from all combustible materials, pending final disposal. If the ashes are disposed of by burial in soil or other wise locally dispersed, they should be retained in the closed container until all cinders have thoroughly cooled.

MAINTENANCE

DOOR / GLASS GASKET AND ASH DRAWER GASKET

A 3/4" (19 mm) spun fiberglass gasket provides the seal around the fuel door and a 1/8" (3.2 mm) x 1" (25.4 mm) flat woven gasket glass provides the seal around the glass. A 1/2" (13 mm) flat fiberglass gasket provides the seal around the ash drawer. Should these gaskets become frayed or damaged, they should be replaced with the same size and type as the original gasket. Contact your dealer for ordering. Use high temperature silicone sealer as an adhesive for the fuel door gasket. The glass and ash drawer gaskets have self-adhesive backing.

WARNING: THE GASKETS MUST BE KEPT IN GOOD CONDITION. DO NOT LEAVE THE STOVE BURNING WITH THE DOOR OR ASH DRAWER OPEN OR AJAR. THIS WILL CAUSE EXCESSIVE HEAT BUILD UP IN THE UNIT AND COULD IGNITE SURROUNDING COMBUSTIBLES AS WELL AS DAMAGE THE STOVE BY OVERFIRING IT. OVERFIRING IS A CONDITION WHERE EXCESSIVE TEMPERATURES ARE REACHED, BEYOND THE DESIGN CAPABILITIES OF THE STOVE (SUCH DAMAGE IS NOT COVERED BY THE MANUFACTURER'S WARRANTY).

SERVICING GLASS

CAUTION: BE CAREFUL NOT TO ABUSE THE DOOR ASSEMBLY BY STRIKING OR SLAMMING IT. IF THE DOOR ASSEMBLY OR GLASS IS BROKEN OR DAMAGED, THEY MUST BE REPLACED BEFORE HEATER CAN BE SAFELY OPERATED. USE ONLY COMPONENTS PROVIDED BY THE MANUFACTURER AS REPLACEMENT PARTS.

Cleaning Glass: Ensure stove is cold prior to cleaning glass. A commercial glass cleaner designed for stoves is recommended. Do not use abrasive cleaners.

Replacing Glass:

1. Remove door from stove by lifting door up and off hinge pins: Place the door on a flat protected (towel) clean flat surface with the inside of the door facing up. Remove the glass clips (by removing screws holding clips), then carefully remove broken glass one piece at a time (protective gloves are recommended).
2. Clean area where the glass with gasket will be installed.
3. Install new glass with gasket (use only factory 5 mm glass with glass channel gasket. Do not substitute). Carefully reinstall glass clips. Be very careful not to overtighten screws.
4. Reinstall door.

CREOSOTE FORMATION AND NEED FOR REMOVAL

What is Creosote - When wood is burned slowly, it produces tar and other organic vapors, which combine with expelled moisture to form creosote. The creosote vapors condense in the relatively cool chimney flue of a slow-burning fire. As a result, creosote residue accumulates on the flue lining. When ignited this creosote makes an extremely hot fire. Also, creosote deposits tend to form in long runs of venting where gases become too cool prior to exhausting. Note: Single wall pipe cools rapidly, therefore installations using this type of flue are more susceptible to creosote deposits.

To inhibit the build up of creosote, adjust the primary air control to a medium-high or high setting for a 10-minute period each day. Do not attempt to burn out heavy creosote accumulations in this manner. This must be removed from the chimney by scraping or brushing to reduce the risk of a chimney fire.

Burn Approved Fuel Only - This stove is approved for burning dry seasoned natural wood only. Using green or inadequately seasoned wood may increase creosote buildup.

Inspection Frequency - The chimney connector and chimney should be inspected at least twice monthly during the heating season to determine if a creosote buildup has occurred. If creosote has accumulated it should be removed to reduce the risk of a chimney fire.

Cleaning - Remove the catalytic combustor and open the bypass damper prior to having your chimney cleaned (should be done by a qualified chimney sweep). See Maintenance Section, *Catalytic Combustor*, page 20 for instructions on removing catalytic combustor.

IMPORTANT: Make sure the bypass damper is in the open position prior to chimney cleaning.

In the event of a chimney fire - Make sure the fuel door is securely closed. Adjust the primary air control to the lowest (most closed) setting. Call the fire department immediately. After a chimney fire, the complete chimney system should be checked by a qualified technician before further use.

Consult your dealer for suggestions on proper chimney care. Contact your local municipal or provincial fire authority for information on how to handle a chimney fire. Have a clearly understood plan for handling a chimney fire.

MAINTENANCE

CATALYST REPLACEMENT

The normal expected life of a catalyst (catalytic combustor) is 10,000 to 12,000 hours if the appliance is operated correctly and proper fuels are used. If the catalyst has been deactivated, it should be replaced. Symptoms of deactivation include – noticeably darker smoke exiting chimney and less heat output. If these symptoms remain after normal maintenance or a major cleaning (see *Catalytic Combustor* on this page for cleaning instructions), the catalyst, p/n 14000 will require replacement. Also, if the catalyst is broken and / or missing large pieces, it should be replaced.

Note: The catalyst does not need to be glowing to be working. It will glow at times, but it can work very effectively at temperatures well below the 1000° F level (at which it will begin to glow).

Stove Operation if Catalyst Is Deactivated – It is safe to operate the appliance temporarily with a deactivated catalyst (although it will be out of compliance with EPA certification requirements). To operate, follow normal lighting and refueling procedures as outlined in this manual with one of the following exceptions.

- During start-up, disregard catalytic temperature probe reading to determine when to close bypass damper control. Instead allow 20-25 minutes, then close the bypass damper control.
- During refueling, disregard catalytic temperature probe reading to determine when to close bypass damper control. Instead allow 3-5 minutes after refueling, then close the bypass damper control.

CATALYTIC COMBUSTOR

This appliance has been designed with a catalytic combustor, which will improve its overall performance. Removing the combustor assembly for cleaning and reinstallation is simple and convenient. Cleaning the combustor helps reduce buildup of ash and retarding chemicals. To clean the combustor, a soft brush, vacuum cleaner, or pipe cleaner may be used.

Cleaning the combustor once a year, preferably when your flue system is serviced, is sufficient for most users. Reinstall the combustor according to the following instructions.

The catalytic activity and effectiveness of a two to three year old combustor can be improved by following this Major Cleaning Procedure - Soak the combustor in a hot cleaning solution of a 50/50 mixture of white vinegar and distilled water for 30 minutes. Then rinse by soaking in hot distilled water. After 15 minutes, remove the combustor from the rinse water and gently shake out excess water. It is unlikely that you will notice a visible difference in the combustor after this cleaning procedure.

The combustor unit is fragile in comparison to the rest of the stove, so handle with care.

1. Place the combustor on the tunnel baffle as shown in illustration (ceramic honeycomb to the back and louvered slots to the front). Push it back into the tunnel baffle until it hits the positioning stops. Make sure it is sitting flat against the bottom and the sides so that it does not tilt forward and jump the positioning stops.
2. Position combustor clip over the middle of the secondary air tube as illustrated. Make sure that one of the holes in the secondary air tube is centered in the ½" (13 mm) hole on the clip. You can feel with your fingertip.
3. Tighten screw snugly, but do not over-tighten or you may spread the clip apart.

Side Cut-Away View of Firebox

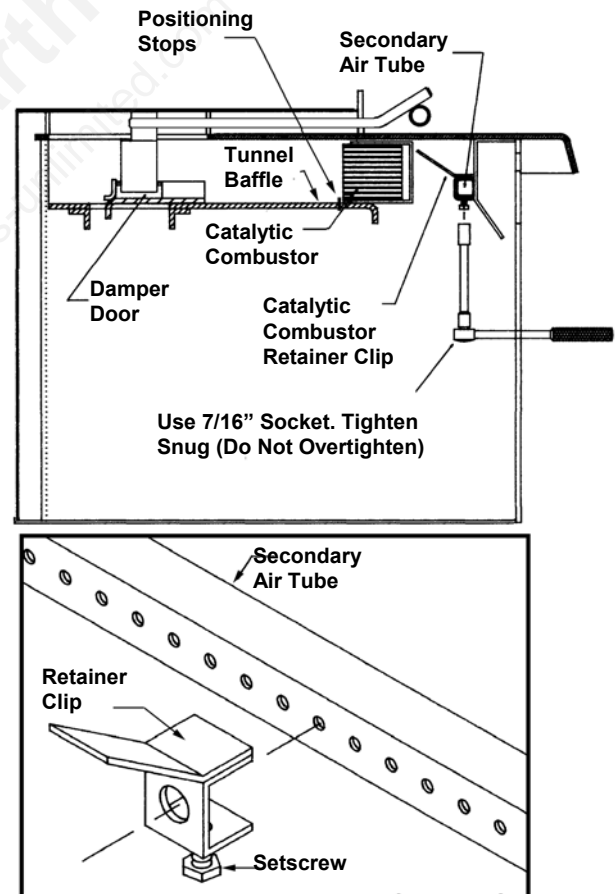

TROUBLESHOOTING

SMOKES OUT FUEL DOOR WHEN OPEN (see ✱)

1. The primary air control is closed.
2. The chimney is too cool. Set the primary air control on "HIGH" with the bypass damper control "OPEN" for a few minutes before opening the fuel door.
3. Excess creosote will not only restrict your draft but it will create a risk of a creosote fire. Strictly adhere to maintenance requirements as outlined in this manual. If excess creosote has built up on the inside of the firebox sides and door, burn a small hot fire at intervals that are more frequent with air control on HIGH for a few minutes.
4. Deposits may have built up in the chimney and are restricting the draft, or the spark arrester on top of the chimney may be plugged.
5. Chimney diameter too large or too small to provide adequate draft.
6. The house is too airtight (usually takes 20 to 30 minutes for problem to appear as stove lowers air pressure in house). Crack a window open or provide an outside source of air near stove.
7. Insufficient vertical height to chimney to achieve adequate draft.
8. The combustor is plugged from engaging too soon (remove combustor and clean, see Maintenance section, page 20).

DOES NOT PRODUCE ENOUGH HEAT (✱)

1. Using green or insufficiently cured wood.
2. Excessive draft.
3. High ceilings (heat rises quickly, but can be recirculated by a well-placed ceiling fan with a winter/summer switch).
4. The area to heat, is too large (square foot heating estimates are based on "average" climates and home design).
5. There's an obstruction in the chimney.
6. The chimney or chimney cap is restricted by creosote preventing enough draw to sustain a "HIGH" heat rate.
7. Combustor light off has not occurred.

DOES NOT MAINTAIN A FIRE (✱)

1. Soft wood does not burn as long or as well as seasoned hardwood resulting in a short burn time.

2. Wood size too small. Burns at too rapid a rate.
3. The gasket seal on the fuel door, ash drawer or glass is leaking air. Repair or replace it if necessary.
4. There is an obstruction in the chimney.
5. The stove was not up to normal operating temperature before the bypass damper control was pushed closed.
6. Excessive draft.

BACKPUFFING (✱)

1. Downdraft in the chimney (may need a special wind cap).
2. The catalytic combustor is too hot (avoid burning soft, pitchy woods, or large amounts of small-diameter wood).
3. The house is too air tight (ventilation is needed).
4. Insufficient vertical height to chimney to achieve adequate draft.

ODORS

1. Creosote accumulation in firebox (brush out on next cleaning).
2. Chimney downdraft when stove is not operating (close primary air control).
3. Catalytic combustor not functioning.
4. Paint curing on first several burns.

DIRTY GLASS (✱)

1. Poor draft conditions.
2. Long burn periods at low draft settings.
3. Burning wet, pitchy or spongy wood.
4. Poorly arranged logs (too close to glass).

(✱) DRAFT PROBLEMS: IF INSTALLING INTO A LARGER FLUE, IT MAY BE NECESSARY TO USE A FULL LENGTH LINER TO ACHIEVE ADEQUATE DRAFT FOR THE APPLIANCE. A DRAFT GAUGE SHOULD READ A MINIMUM OF .05" W.C. (INCHES WATER COLUMN) NOT TO EXCEED .07" W.C. FOR OPTIMUM PERFORMANCE (See *Draft Requirements*, page 11).

TROUBLESHOOTING

CATALYST PLUGGING

1. Burning materials that produce a lot of char and fly ash. Do not burn materials such as garbage, gift wrap, cardboard, etc.
2. Burning wet pitchy woods or burning large loads of small diameter wood with the combustor in the operation position (without light-off taking place). Burn proper fuel only. Do not close bypass until temperatures are high enough to initiate light off.

CATALYST DEACTIVATION

1. Burning large quantities of trash, pressure-treated lumber or painted woods, etc. will deactivate the catalyst. Burn proper fuels only. See *Catalyst Replacement*, page 20.

CATALYST SUBSTRATE CRACKING

1. Normal operation, as long as combustor remains intact. If cracking causes large pieces to fall out, replace combustor.
2. Mishandling or abuse. Handle with care.
3. Excessive draft. Correct installation. See *Draft Requirements*, page 11.

CATALYST SUBSTRATE

1. Extreme thermal shock. Combustor is being worked too hard.
2. Excessive draft. Correct installation. See *Draft Requirements*, page 11.

CATALYST PEELING

Extreme Temperatures (over-firing) at combustor surface can cause the catalyst to peel. Some minor peeling does not affect function. Severe peeling would close cell openings and cause a plugging problem. If peeling is severe, replace combustor. Do not overfire appliance. See *Overfiring*, on page 23.

TAR AND LIQUID CREOSOTE LEAKING FROM METAL FLUE JOINTS

1. No chimney cap on chimney. Install cap.

2. Metal flue assembled improperly. Top flue sections should be inserted into lower flue sections.

DENSE SMOKE LEAVING CHIMNEY

1. Water vapor (on cold still days water vapor may be mistaken for smoke). Water vapor is normal and should be of little concern.
2. Wet, pitchy woods being burned. Burn dry seasoned wood only.
3. Bypass in open position. Close bypass.
4. Combustor not functioning. See *Catalyst Replacement*, page 20.

NOISY HEAT SHIELD (OIL CANNING)

Rear or side heat shields make a noise (bong) during heat up or cool down.

Large pieces of metal such as a side or rear heat shield on a stove will normally expand and retract as it heats and cools. If a noise develops in these shields (i.e. as component heats and expands, it may flex, resulting in a “bong” sound) it can be corrected. See following procedures:

There is an adjustable tension bolt in the center of the rear heat shield. To eliminate the expansion noise during stove use, adjust the bolt and nut to increase tension on the shield.

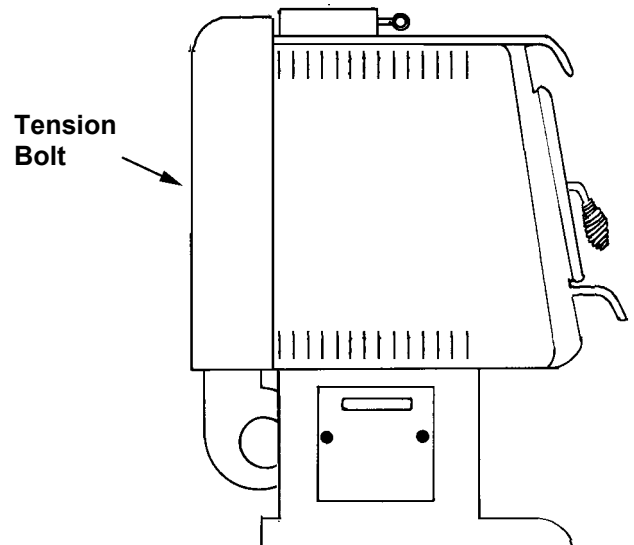

TROUBLESHOOTING

OVERFIRING DAMAGE

If the heater or chimney connector glows, the appliance is overfiring. Other symptoms may include: Cracking, warping or burning out of components, catalytic combustor may deteriorate, gold doors may turn color, stove glass may develop a haze which will not come off with cleaning, firebox baffle plate (tunnel baffle) may warp, etc. Overfiring of a stove is a condition where excessive temperatures are reached, beyond the design capabilities of the appliance. The damage that occurs from overfiring is not covered under the manufacturers limited warranty. The following are a few conditions that should be evaluated and (corrected if necessary) if an overfiring condition is suspected:

Overfiring Caused From Improper Installation

The venting system must satisfy the draft Requirements of the appliance. The appliance is merely one component of a larger system. The other equally important component is the venting system, which is necessary for achieving the required flow of combustion air to the fire chamber and for safely removing unwanted combustion byproducts from the appliance. If the venting system's design does not promote these ends, the system may not function properly, which may create performance problems as well as may be a safety hazard. To ensure that all installation requirements have been met as outlined in the installation manual. The chimney should be clean and in good repair. A draft test should be performed to determine if the draft requirements of the appliance are being met. A draft gauge should read between .05 and .07 inches water column (W.C.I.).

Excessive draft (above .07 W.C.I.) will allow too much combustion air to be pulled into the firebox, which results in hotter burns. Too little draft (below .05 W.C.I.) will not allow enough combustion air delivery to maintain a fire well or cause performance problems such as smoking (this may result in improper operation of appliance, i.e. will not maintain fire well unless catalytic bypass is left open, or with fuel door left open (see below - *Overfiring Caused From Improper Operation*).

Overfiring Caused From Improper Operation

Never burn the appliance with the fuel door open or ajar, or the ash drawer open. Never burn the stove with the bypass handle in the open position once the fire has been established or the air control in the "high" position for extended periods.

Overfiring Caused From Improper Maintenance

Should the fuel door, glass or ash drawer gaskets become worn or damaged, they should be replaced.

Overfiring Caused From Improper Fuel

This appliance is approved for use with natural dry well seasoned wood only (consult your dealer for approved fuels in your area). Do not burn garbage, particleboard scraps, or pressed logs using bonding agents because they can produce conditions that will deteriorate metal. Green or uncured wood does not work well as fuel, and can cause increased creosote buildups. Do not overload or use kindling wood or mill ends as primary fuel.

SPECIFICATIONS: Model 1003C

Maximum Log Length	18" (458 mm)
Manufactured (Mobile) Home Approved	Yes, U.S.A. and Canada
Outside Air Provision	Yes
Flue Collar Size	6" (153 mm)
Flue Position	Top
Stove Back to Flue Center	9" (229 mm)
Width	25.25" (642 mm)
Depth	27" (686 mm)
Height (to flue)	34.5" (877 mm)
Height	32.5" (826 mm)
Approx. Burn Time	8 - 12 hours
Fuel Capacity	50 - 70 lbs. (23 - 32 kg)
Fire Box Size	3 cubic feet (914 cubic millimeters)
Loading	Front
Catalyst	Standard
Maximum Burn Rate	51,100 BTU
EPA BTU Range	11,700 - 36,800 BTU
EPA Efficiency	72 %
Emissions Rate (gram/hour)	3.7 gph
Approx. Weight With Brick	360 lbs. (168 kg)
Blower (Optional) W/ speed control	160 CFM, .9 amp, Rheostat (75v - 110v)

Side View

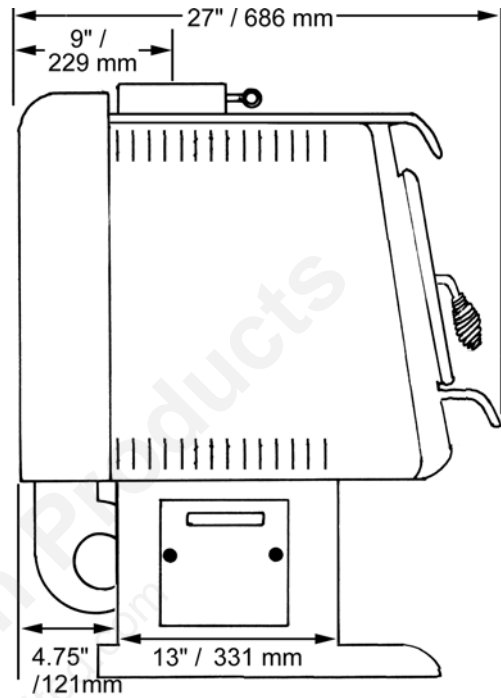

Front View

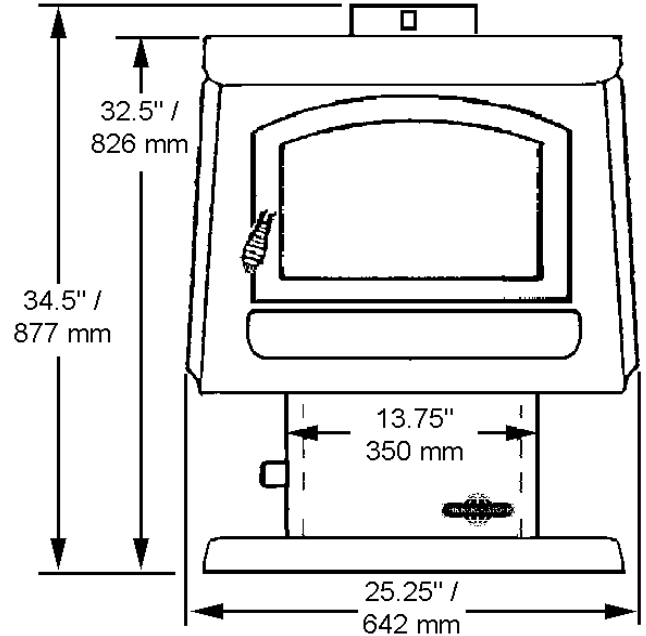

Note: Dimensions shown are approximations only (+/- 1/4" - 6.4 mm).

Door Sold Separately

REPLACEMENT PARTS LIST: Model 1003C

ITEM NO	DESCRIPTION
Door Parts	
27M65	Clip Kit, Glass
G6000	Door Assembly, Black, H0533 (handle included)
14M72	Door Assembly, Gold, G3000 (handle included)
86-128	Gasket Kit, Door (3/4" rope, includes adhesive)
27M81	Gasket Kit, Glass (10' of 10580. self adhesive backing)
G2000-7	Glass, Small Arched, 9 3/8 x 15 3/4" (gasket not included)
10300	Handle Assembly, Door
11531	Hinge Pin, Retrofit (2 if set is needed)
10362	Torque Plate (latch)
Draft Module Parts	
907	Handle, Spring Module (00907)
26M29	Module Assembly, Draft (11658)
Catalytic Combustor Parts	
11000	Clip, Combustor (bracket w/ setscrew)
CLIP-2	Clip, Combustor (stair step clip)
14000	Combustor Assembly, 3" - Includes ceramics, gasket & housing
11481H	Gasket, Interam Combustor (1/16 x 3 x 36") - 11481
C-200-51	Hook, Damper (coil handle with hook for opening / closing damper bypass)
11485	Housing, Combustor (also requires 1 each P/N 11481H)
H0310	Probe, Combustor Temperature (Z-SC-107)
Room Air Blower Parts (if optional blower is installed)	
14M22	Blower Kit (includes Dial-A-Temp) - 820
14440	Rheostat, Dial-A-Temp
14M21	Stove Stat Kit (automates fan) - 18840
Miscellaneous Parts	
1100	Ash Drawer Assembly (01100)
14M67	Duct, Floor, 5 1/4" Square, 78-35 (for pedestal based models)
27M80H	Gasket Kit, Ash Drawer, 3/8" x 1/8" (16' of 01098)
1135	Knob, Ash Drawer (01135)
70K99	Paint, Metallic Black, 12 oz Spray Can, 76-141MB (#6309)
Firebox Parts	
26M27	Damper Kit (includes damper, linkage and rod)
FB14	Firebrick, 6 3/4 x 3 x 2 3/8" Left (requires 1) ♦
FB15	Firebrick, 6 3/4 x 3 x 2 3/8" Right (requires 1) ♦
FB12	Firebrick, 7 3/8 x 4 1/2 x 6 3/4" Left (requires 1) ♦
FB13	Firebrick, 7 3/8 x 4 1/2 x 6 3/4" Right (requires 1) ♦
FB-1	Firebrick, 9 x 4 1/2" Regular (order 5, if set is needed) ♦
FB-2	Firebrick, 9 x 4 1/2" w/Notch (order 8, if set is needed) ♦
1115	Grate, Cast Iron (SN>3200 approx.) - 01115

REPLACEMENT PARTS LIST: Model 1003C

Cat. No.	Model	Description
/ Part No.		Firebrick - All firebrick are 1 ¼" thick (see firebrick diagram below)
FB-1		Firebrick, 9 x 4 ½" Regular (order 5, if set is needed)
FB-2		Firebrick, 9 x 4 ½" W/Notch (order 8, if set is needed)
FB12		Firebrick, 7 3/8 x 4 ½ x 6 ¾" Left (requires 1)
FB13		Firebrick, 7 3/8 x 4 ½ x 6 ¾" Right (requires 1)
FB14		Firebrick, 6 ¾ x 3 x 2 3/8" Left (requires 1)
FB15		Firebrick, 6 ¾ x 3 x 2 3/8" Right (requires 1)
1115		Grate, Cast Iron

Firebrick

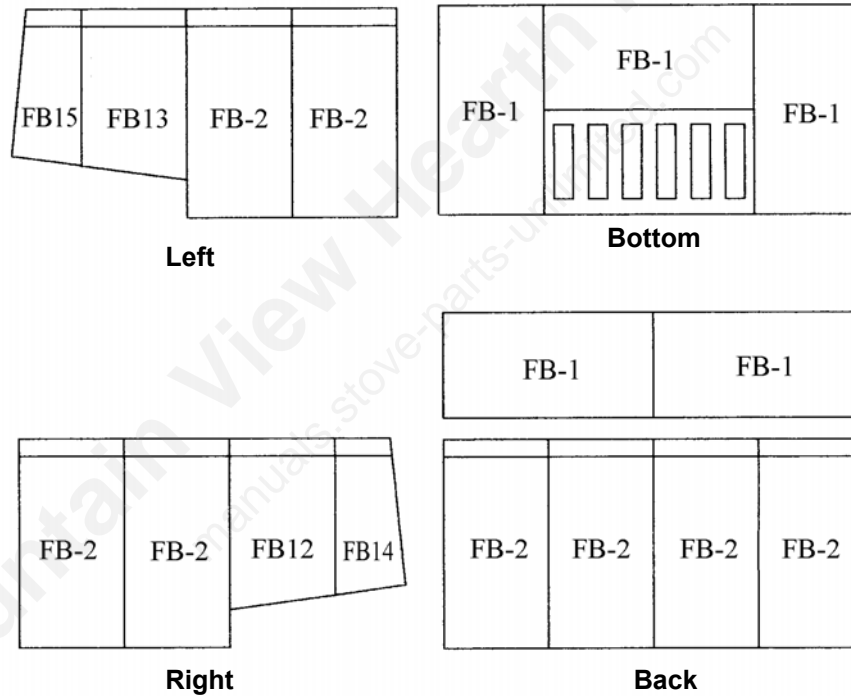

For the location of the nearest Dealer for replacement parts, contact:
Lennox Hearth Products
1110 West Taft Avenue
Orange, CA 92865

COMPONENT DIAGRAMS - Model 1003C

Catalytic Combustor System Components

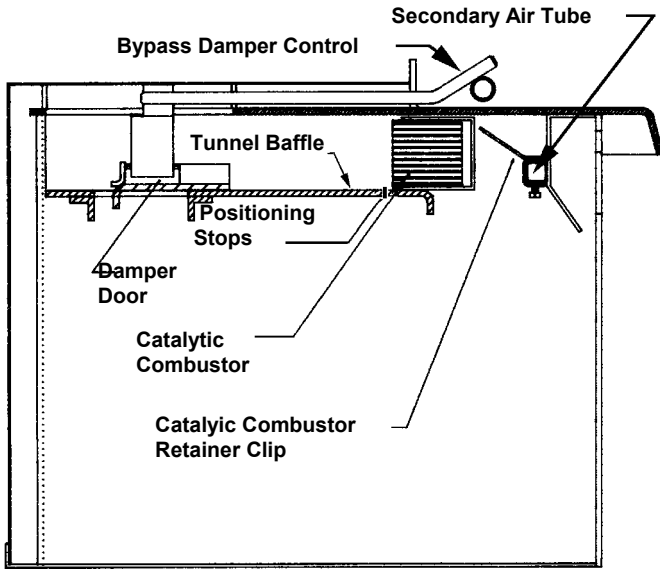

Air Intake Draft Module

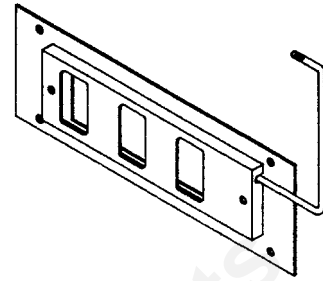

Door Assembly

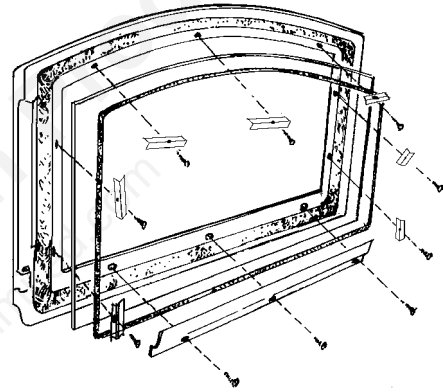

Damper Assembly

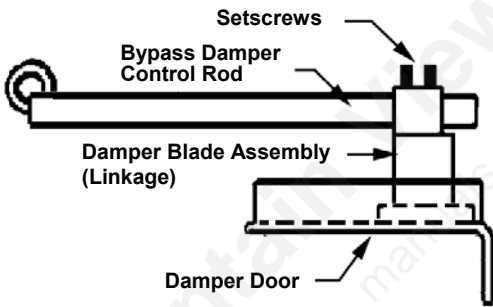

Handle Assembly (P/N LB-102214)

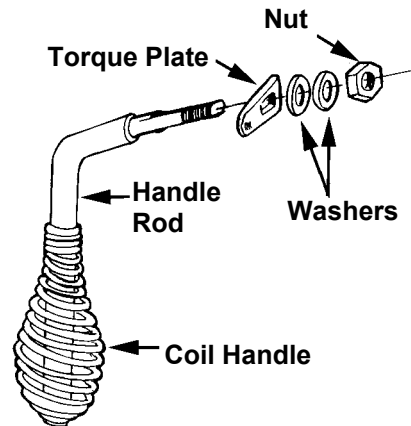

OPTIONAL ACCESSORIES - Model 1003C

Note: Install and use accessories per instructions provided with the accessory kit.

Catalog #	Model	Description
14M67	OAFD-S	Outside Air Floor Duct
* 14M72	DK100-G	Gold Door Kit
* H0533	DK100-B	Black Door Kit
14M22	BK-100	Blower Kit
14M21	SSK	Stove Stat Kit
70K99	TSPK-B	Touch-up Spray Paint Kit, Black (12 oz spray can)

Stove-Stat Kit (SSK)

To automate the blower system an additional Stove-Stat kit can be purchased. The Stove-Stat is a heat sensor switch that will automatically turn on the blower when the stove is hot and automatically turn it off when the stove is cool.

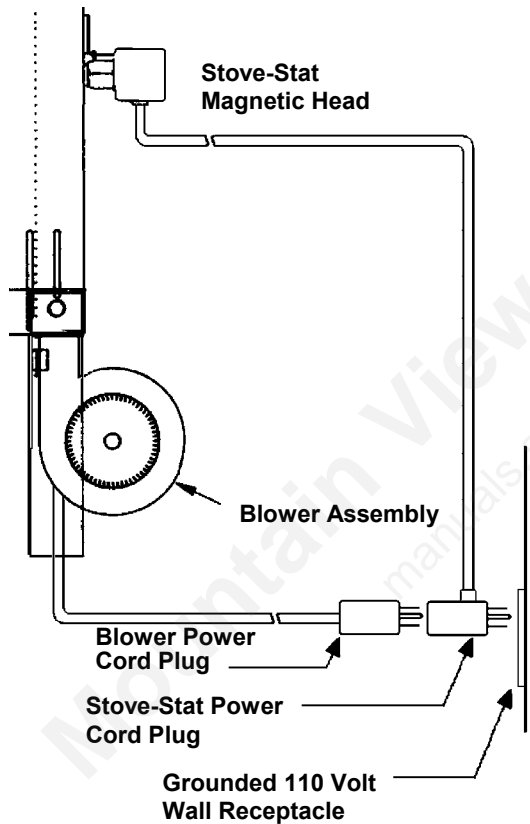

Outside Air Floor Duct (OAFD-S)

Outside air can be delivered for combustion air by utilizing this floor penetration duct.

(Duct penetration measures 5 1/4" square)

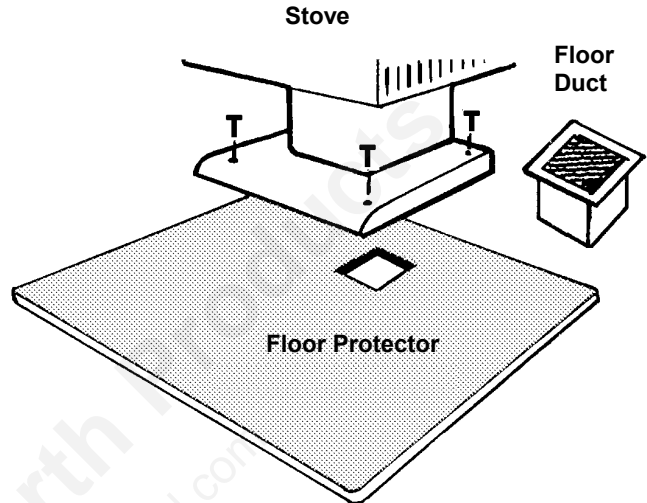

Blower Kit (BK-100)

A Blower Kit (includes rheostat for variable speed control) is available for increased heat circulation.

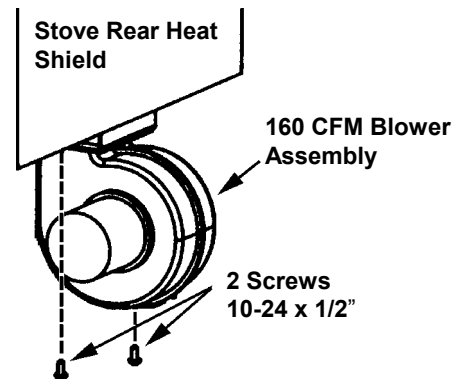

Variable Speed Control, Dial-A-Temp

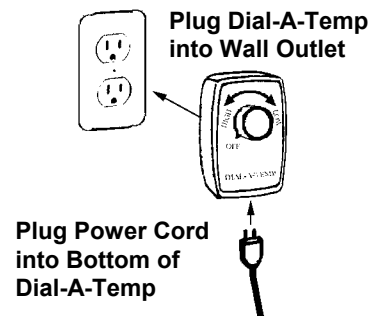

EPA LABEL

Manufactured by Lennox Hearth Products Model: 1003C-3

US ENVIRONMENTAL PROTECTION AGENCY

CATALYST EQUIPPED

MEETS EPA PARTICULATE MATTER (SMOKE) CONTROL REQUIREMENTS FOR CATALYTIC WOOD HEATERS BUILT ON OR AFTER JULY 1, 1990. SEE CATALYST WARRANTY. ILLEGAL TO OPERATE WHEN CATALYST IS NOT WORKING. SEE OWNER'S MANUAL FOR OPERATION AND MAINTENANCE.

SMOKE

THIS MODEL

0 (Grams Per Hour) 5.5

EFFICIENCY

50% 60% 70% 80% 90% 100%

Wood heaters with higher efficiencies cost less to operate.
***(NOT TESTED FOR EFFICIENCY. THE VALUE INDICATED IS FOR SIMILAR CATALYST-EQUIPPED WOOD HEATERS.)**

HEAT OUTPUT
11,700 to 36,800 Btu/Hr

Use this to choose the right size appliance for your needs.
ASK DEALER FOR HELP

This wood heater will achieve low smoke output and high efficiency only if properly operated and maintained. See owner's manual.

Mountain View Hearth Products
manuals.stove-parts-unlimited.com

LENNOX[®]

HEARTH PRODUCTS
1110 West Taft Avenue
Orange, CA 92865