

Natural
F I R E
PELLET STOVES

INSTALLATION
AND OPERATION MANUAL

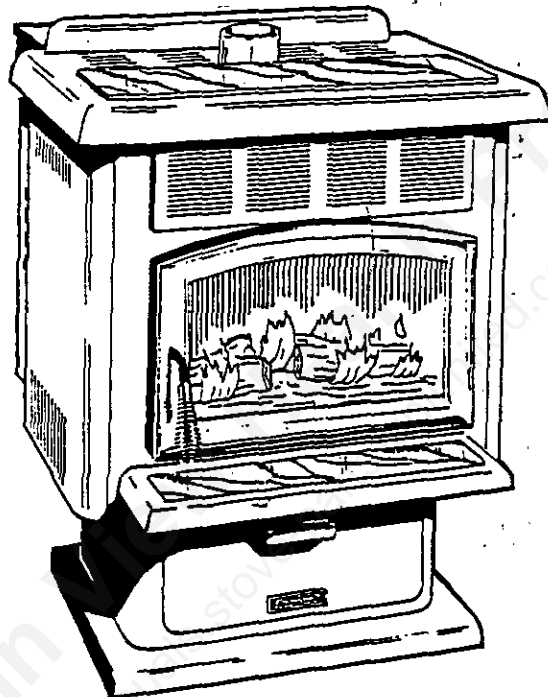

MODEL MP250



This equipment must be installed by a Qualified Technician.
Read thoroughly before starting installation.
Save this manual for future reference.

Rev. 4/92

IMPORTANT SAFETY NOTICE

PLEASE READ BEFORE ATTEMPTING TO BURN!

CAUTION: *If this stove is not properly installed, a house fire may result. For your safety, follow the installation directions; contact local building officials about restrictions and installation inspection requirements in your area.*

1. Installation of this stove must comply with local codes. A building or installation permit may be required. Be sure to check with your local building or fire department before installing.
2. Have your fireplace and chimney system inspected by a qualified person prior to installation of the stove. Make any necessary repairs before installing.
3. Never connect stove flue to chimney being presently used by another heater.
4. Never block any air intake or air outlet ports. Dangerous overheating can result.
5. Do not install this stove in a sleeping room.
6. Never connect the stove to an air duct system.
7. Never stack or pile combustible materials against the stove or around external vent termination.
8. To avoid burns, children and adults should be alerted to the hazards of high surface temperatures.
9. To provide reasonable fire safety, install a smoke detector and a conveniently located fire extinguisher.
10. In the event of a chimney fire, notify the fire department and unplug the stove and close all openings.
11. Terminate pellet vent pipe so that contact with humans or possible damage to pipe is avoided.
12. Required fuel is: 1/4" diameter pellets, 8500 BTU per pound, 10% maximum moisture content, 1%-3% ash. Corn kernels, 10,000 BTU per pound, 15% maximum moisture content (Optional Cornpot required.)

Testing/Listing

This stove has been tested and listed for use in residential construction in accordance with applicable UL standards, and for manufactured housing in accordance with OAR 814-23-900 through 814-23-909, by Pacific Inspection and Research Laboratory, Inc., (PIRL) Redmond, WA 98052.

Based on a tested air to fuel ratio in excess of 35:1, this appliance is not an effected facility under the EPA regulations for woodburning stoves.

INTRODUCTION

Read Entire Manual Before Attempting to Burn

OVERVIEW

Gold Door

Your Earth Stove's Gold Door Frame should be cleaned thoroughly with a good window cleaning solution and a soft cloth BEFORE the stove is burned. Do not use any metal polishes or abrasives to clean the door. Any oils or fingerprints left on the Gold could become permanent blemishes if the stove is burned prior to their removal. After the first few fires the Gold will cure.

Glass

The Glass is a super heat resistant ceramic that withstands continuous temperatures up to 1390° F. This temperature is well beyond the temperatures in which you operate your stove. After long periods of pilot operation some soot may form on the Glass.

Ash Drawer

The Ash Drawer located in the front of the pedestal is designed to make cleaning easier by containing the ashes in a removable drawer. It is accessed by turning the spring loaded screws located on the Ash Drawer Cover. Do not operate the stove with the Ash Drawer open or ajar. Replace gasket material as necessary to insure a tight seal.

Decorative Logs

An important feature of your NaturalFire stove is the realistic fire created by the flame spread Firepot and the refractory logs. Although the logs are quite durable, they should be handled carefully, as they retain heat for a considerable period of time, and if dropped can break.

Placement of the logs is important in achieving a realistic fire. One recommended pattern is pictured below which allows you to use a Firepot cleaner without having to remove the logs (except for full maintenance).

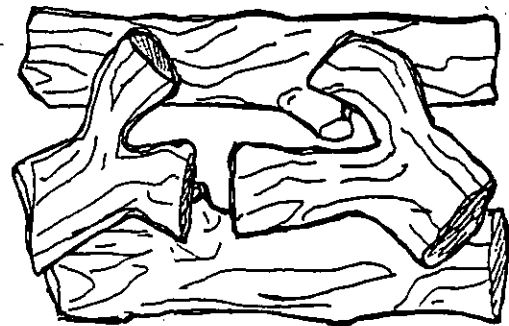

OVERVIEW

Marble

Marble is a natural product so each piece will have its own unique character. Marble may be cleaned with a damp cloth to remove oils or dust. Be sure to install the four cerawool strips (under the marble) to protect it. Do not put rough objects (such as trivets/steamers/hopper lids) on the surface. Do not install the Marble before curing the paint.

Control Panel/Fan Rheostat

The Primary Control Board (Model 1000) manages the performance of your stove. It allows you to regulate the fuel feed rate, the Draft Fan pilot and main power to the stove. The Room Air Fan Rheostat allows you to manually regulate the fan speed except when the automatic high speed override is engaged.

Three Pronged Plug (Grounded)

Your stove has a printed circuit board and other electrical components that require a grounded circuit and proper polarity. Purchasing a surge protector provides additional insurance against unnecessary problems.

Firepot

The pellet Firepot is where the fuel is burned. Although it has a self cleaning capability for much of the ash build up, variable fuel quality (ash content) and extended periods of a low burn rate will necessitate some manual cleaning. An Earth Stove Firepot cleaning tool is highly recommended (part #1000).

Hopper

The Hopper is where the fuel is stored before it feeds into the stove.

How It Works

The Fuel Metering Cup rotates in the throat of the Hopper providing a measured amount of fuel based on the set Feed Rate. The fuel drops into the Auger Tube where it is moved into the Firepot. The Draft Fan provides combustion air through the Auger Tube and a series of holes in the inner Firepot, to allow for complete combustion.

The flame and hot gases provide heat to the Heat Exchange Tubes located in the upper chamber of the stove. The Room Air Fan(s) extracts the heat and delivers it to the room, along with the natural radiant heat from the glass and metal surfaces.

OPERATION

Before Attempting To Start Your Stove, Read This Manual Thoroughly.
Have Your Stove Pretested and Professionally Installed.

Start Up Procedure

1. Plug in the stove. Fill hopper with pellet fuel.
2. Turn the Main Power Switch to the "Feed System" position.
3. Provide starting fuel by pushing the "Start Button" and allow fuel to feed for approximately five minutes (or put approximately two cups of fuel directly in the Firepot).
4. Turn the Main Power Switch to the "Stove Off" position. (This will stop the fuel feed.)
5. Open fire door and apply Fire Starter gel to the fuel in the Firepot, then light. Allow the fuel to burn for five minutes with the door slightly ajar.
6. Close the door.
7. Turn the Main Power Switch to the "Feed System" position, then push the Start Button.
8. Set the Fuel Rate Switch to the "Full" position. If using a remote Thermostat, adjust it to the desired room temperature.
9. As the stove temperature rises, the Room Air Fan(s) will automatically engage. At that point, adjust the Fuel Rate Switch to the desired setting. During the start up procedure or when running the stove on a "Low" Fuel Rate Setting, the Room Air Fan Rheostat must be in the off position. Failure to do so could cool down the stove and it will automatically shut off.
10. If the fire goes out, go back to step two again.

Shut Down Procedure

1. Turn the Main Power Switch to the "Draft Fan" position. If using a remote Thermostat, turn the Thermostat down.
2. When the fire in the Firepot goes out completely, shut the Main Power Switch to the "Stove Off" position.

OPERATION

Control Board Model 1000

A. Main Power Switch

The Main Power Switch is a three way toggle with the following positions:

1. Stove Off
2. Draft Fan - allows the Draft Fan to operate alone during shut down.
3. Feed System - Stove On

B. Fuel Rate Switch

The Fuel Rate Switch controls the amount of time the burner feeds fuel. It can be set to the following three positions:

1. Full - will feed fuel continuously.
2. Medium - will feed fuel approximately two minutes on then two minutes off.
3. Low - will feed approximately one minute on then three minutes off.

C. Draft Fan Switch

The Draft Fan Switch controls the amount of air used for combustion and aids in the draft of the stove. It can be set to the following three positions:

1. High - runs at 75% of capacity when stove is not feeding fuel.
2. Low - runs at 50% of capacity when stove is not feeding fuel.
3. Off - runs at 0% of capacity when stove is not feeding fuel.

NOTE: The Draft Fan will run at 100% of capacity during the feeding of fuel after the stove has reached normal operating temperatures.

D. Start Button

Depress the Start Button to allow fuel to feed for approximately 12 minutes (used during the start up of the stove).

E. On/Off Light

The On/Off Light blinks to indicate electricity is flowing through the Primary Control Board.

F. Fuse

The Fuse protects the Primary Control Board from power "surges or spikes".

G. Room Air Fan Rheostat

The Room Air Fan Rheostat can be used to vary the speed of the Room Air Fan by rotating it to the desired setting. When the stove is very hot, the Rheostat override (Fan Speed Disc) will automatically run the fan on high until the stove cools.

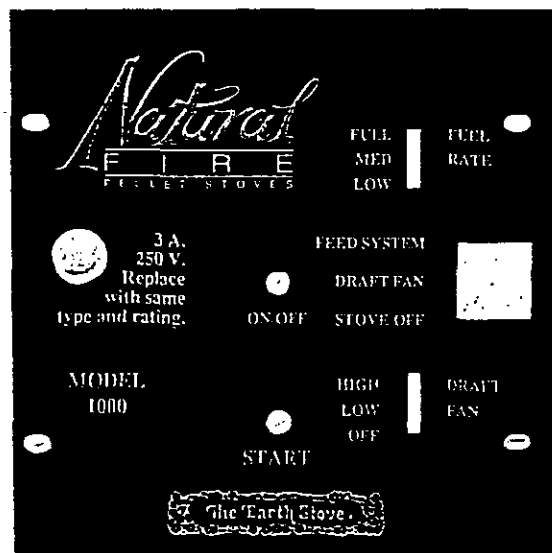

OPERATION

Normal Operating Sounds

Heat Exchange Tubes - As the Room Air Fan(s) increase in speed, you may hear air being forced through these tubes and out into the room.

Thermostatic Control Disc - There are four different heat activated temperature discs on the stove. The discs can make a light clicking sound as the stove heats up or cools down.

Room Air Fan(s) - The modern, high efficiency fan may have a hum or pulsating sound, particularly on the high setting. The sound may change as the fan speed is varied.

Auger Feed System - When fuel is fed from the Hopper to the Auger Tube, a light clinking sound or the fuel being cut may be heard.

Auger/Cup Motor(s) - When feeding fuel, you may hear the intermittent buzz or hum of these motors.

Draft Fan - This motor runs at various speeds to provide combustion air to the Firepot (and to aid in the draft of the flue). The speed of this motor will increase with the feeding of fuel.

Optional Remote Thermostat

One way to maximize the efficiency and convenience of your stove is to install a remote Thermostat. A Honeywell T87F 24 volt Thermostat is recommended.

Follow the manufacturer's installation instructions using 18/2 stat wire. The leads from the stove are the yellow wires found behind the Primary Control Board.

Once you have installed the Thermostat, the Fuel Rate Switch should be set to "Low". This will be the rate the stove will pilot at when the Thermostat is not calling for heat.



Product Bulletin

Model MP35/50 & MP250

6-29-94

INSTALLATION OF P/N15169C CORNPOT INTO MODELS MP35/50 & MP250.

The cornpot (p/n15169C) will not fit into models MP35/50 and MP250 without removing the ash skirt. The ash skirt is a nonfunctional part and is not necessary for burning corn. If you wish a replacement ash skirt (for model MP35/50 only) with steeper side angles which will allow fit of this cornpot, contact your regional Warranty & Technical Support Department.

REMOVAL OF ASH SKIRT:

This part is secured in place with silicone and is easily removed by grabbing the back corners and pulling up until the silicone breaks loose. To break the seal on the front lip of the ash skirt it may be necessary to pry upward with a screwdriver.

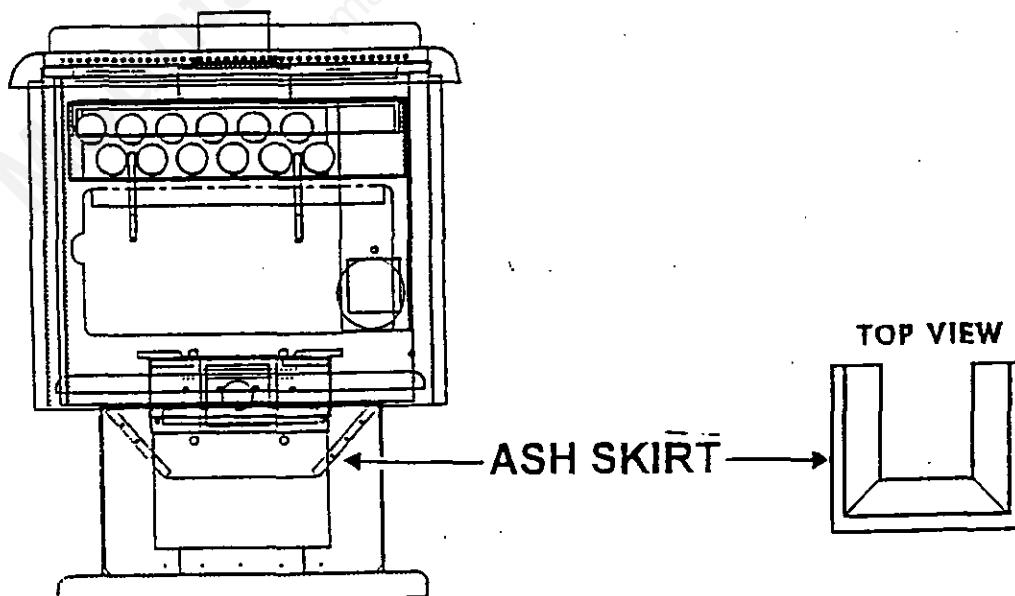

BURNING CORN (Optional)

Natural Fire pellet stoves will burn most types of corn with the addition of a Corn Pot kit. It is not necessary to mix corn with wood pellets however, wood pellets are required to start the fire. NOTE: Burning treated seed corn is never recommended.

The Corn Pot kit consists of:

- 1 1/8" Filler Plug
- 1 3/8" Filler Plug
- 1 Corn Pot

To install the Corn Pot, simply remove the screw(s) from the top of the Auger Housing and lift up and out on the Firepot. Slide mounting flange of the Corn Pot over the Auger Housing and replace screw(s).

Initially the Air Shutter on the Draft Fan should be set at 1/2 open and the Draft Fan selector on "LOW". If more or less combustion air is needed, adjust the Air Shutter accordingly to achieve a bright yellow flame.

Because corn size and density varies, it will be necessary to calibrate the Fuel Metering Cup in order to maintain rated BTU input and prevent overfiring. This requires the installation of the Filler Plug in the Fuel Metering Cup. Use the 3/8" filler plug provided in the Cornpot kit.

The moisture content of the corn should be 15% or less, and care should be taken to ensure that there are no foreign objects in the corn (i.e. stocks, stalks, cob parts, etc.).

When burning corn, the primary combustion takes place on a bed at the bottom of the Corn Pot. The Corn Pot has a solid bottom and sides with air holes because burning corn forms a fluid-like residue which becomes solid when cool. The Corn Pot cleaning will depend upon the quality and quantity of corn being used. The Cornpot should be cleaned when the build up starts to reach the bottom air holes inside of the Cornpot. You will need to remove the ash, and in some instances a white calcium like deposit. The stove must be shut down and cooled before cleaning.

Corn burning should be done in top vent installations only. If the installation must elbow into a wall thimble, the horizontal run should not be more than 24". The use of a wall mounted Thermostat, part #CTR140 is suggested.

Start Up Procedure

We recommend starting a corn fire with wood pellets because corn has a dense shell that can be difficult to start. Manually fill the Cornpot, to the bottom of the Auger Tube, with wood pellets. Use of the Start Button feature is not recommended when initially starting the unit for corn burning. (See "Start Up Procedure" in the Operation section for additional start up information.)

MAINTENANCE

Ash Removal and Disposal

CAUTION: BE SURE THE FIRE IS OUT AND STOVE IS COLD BEFORE REMOVING ASHES! NEVER BURN YOUR STOVE WITH THE ASH DRAWER OPEN.

Ashes can hold live embers for several days, and must be disposed of with care. Be certain the fire is out before you remove the Ash Drawer. Brush ashes into the Ash Drawer. After emptying, clean and replace the Ash Drawer and tighten the spring loaded screws. NEVER place ashes in a cardboard box or any other combustible receptacle. Place the ashes in a metal container with a tight fitting metal lid. The closed container should be stored on a noncombustible surface, away from combustible materials. Keep the ashes in the closed container until you are certain all the cinders have completely cooled. Replace Ash Drawer Gasket if it becomes damaged.

Door Gasket

A spun fiberglass gasket (3/4" in diameter) provides the seal around the fuel door. Should this become frayed or damaged it should be replaced. Spun fiberglass "rope" gasketing can be purchased from your dealer or some hardware stores. It must be the same diameter as the original. Use high temperature (RTV) silicone sealer as an adhesive.

WARNING: MAINTAIN THE DOOR SEAL IN GOOD CONDITION. DO NOT LEAVE THE STOVE BURNING WITH THE DOOR OPEN OR AJAR. DO NOT USE ANY TYPE OF ABRASIVE CLEANER OR POLISH ON GOLD PLATING.

Creosote Formation and Need for Removal

If your stove is properly adjusted, very little creosote will develop in your flue system. If creosote begins to develop, it is likely that poor adjustment or needed maintenance is causing incomplete combustion of the fuel. Be sure your Draft Fan Switch, and Draft Fan shutter are set properly.

Soft fly ash is a normal by product of burning pellet fuel, and can accumulate in your flue system. Using lower grade fuel will increase the frequency of cleaning that will be needed. Check your flue regularly (at least once a month) until a schedule can be established for your installation and fuel quality.

Remember, during high use periods to increase your inspection cycle.

Paint

Your stove finish is a high temp paint that requires time and temperature to completely cure. Depending on your use, this may take a few hours or a few days. Do not attempt to repaint the stove until the paint is completely cured. Do not place anything on the stove surface until the stove has gone through several heat up/cool down cycles, as the paint will become soft before it cures.

Fan(s)

At least once each year, check the Room Air and Draft Fans inlets for deposits from carpeting, pet hair, furniture coverings, etc. Use a brush and/or light vacuuming for cleaning. Oiling the fans is not necessary.

MAINTENANCE

Firepot

Keep the Firepot inner holes free of obstructions (buildup). Pull the Firepot and empty it when this occurs. The quality and quantity of pellets used will dictate the necessary cleaning. Remove clinkers or carbon build up.

Clinkers are a byproduct of the fuel. Silica (or dirt) in the fuel, along with other impurities can fuse under heat and cause clinkering. Clinkering is a function of the fuel, not the stove. A clinker should be removed using a clean out tool.

Refractory Logs

The following steps will insure the longevity of your logs:

1. Never attempt to handle them while they are hot.
2. Use a "Natural Fire" Firepot cleaner tool (Part #1000) to remove ashes from the Firepot. In many cases you can do this without removing any logs. Except when cleaning out the bottom of the stove, do not remove the large 1/4 Logs.

Cleaning the MP250

1. Turn the unit off two to three hours before cleaning to allow the unit to cool (see Shut Down procedure).
2. Place protective floor covering around the front of the stove.

3. CAREFULLY remove the decorative logs from the Firebox and set them aside. Remove the Baffle Plate.
4. Remove the Firepot by removing screw(s) from the auger housing and pulling up and out. Back out bolt on Clean Out Access Plate and remove.
5. Remove Ash Drawer and empty ashes into your noncombustible container. Dispose of ashes as previously described (see ash removal and disposal). Clean any remaining ash from the Firebox and Ash Drawer area.
6. After the stove chimney has been swept, the top/rear chimney seal off plate needs to be pulled off of the stove to vacuum the unit out.

There is a upper Baffle Plate (see page 10) between the top of the Heat Exchange Tubes and the top of the stove. Fly ash will accumulate on this plate and must be removed or your flue will become clogged. You should also remove the dust and fly ash which accumulates on the Heat Exchange Tubes.

7. Vacuum the Clean Out Access.
8. Reinstall your Firepot being sure that the Auger Tube protrudes about 1/8" into the Firepot. Replace baffle and clean out access. Reseal and secure stove chimney.

The necessary frequency of this procedure will be dictated by the quality and quantity of the fuel burned.

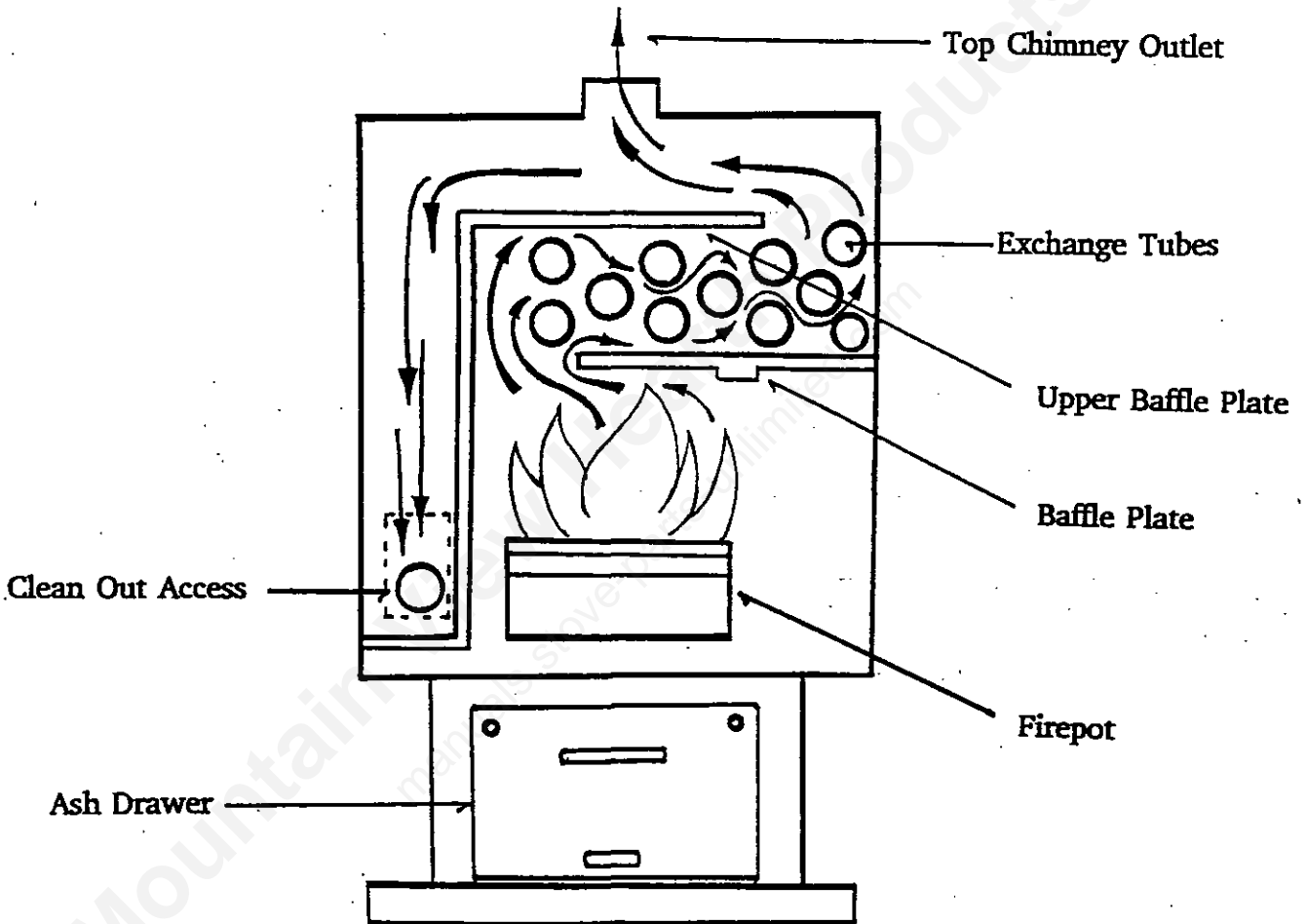

MAINTENANCE

Maintenance Suggestions

As with all appliances, periodic maintenance is required to keep them operating at optimum efficiency. We recommend an annual maintenance service by a qualified technician.

Recommended Maintenance Points

- A. Once for every ton of fuel burned, use a brush and remove all dust and fly ash from Heat Exchange Tubes and Baffle areas.
- B. Remove and clean the Firepot. Keep inner air holes free from buildup. Remove ashes from the Firebox.
- C. Clean chimney, cap and exhaust passage way annually or as needed. Inspect monthly.
- D. Vacuum air intakes and squirrel cage on Room Air Fan(s) annually.
- E. Clean squirrel cage on Draft Fan annually.
- F. If remote Thermostat is used, remove cover and clean contacts annually.
- G. Replace Door Gasket as needed.
- H. Replace Ash Drawer Door Gasket as needed.

Maintenance Related Problems

Problem: Decrease in heat output or incomplete combustion.

Solution: See maintenance points A, B, C, D and E (above).

Problem: Decrease in Room Air Fan(s) velocity.

Solution: See maintenance point D (above).

Problem: Stove smokes or odor in home.

Solution: See maintenance points A, B, C, G and H (above).

Problem: Flames appear to burn lazily.

Solution: See maintenance points A, B, C, and E (above).

Problem: Noticeable change in Room Air Fan(s) noise.

Solution: See maintenance point D (above).

If solutions fail to cure problem, See Trouble Shooting Section.

INSTALLATION

Recommended Pre-Installation Procedure

NOTE TO INSTALLER: Before the unit is installed it is recommended that the unit be pre-burned to verify the operation, to burn off oils that are sometimes found in the Heat Exchange Tubes, and to cure the paint. The "Pre-Installation Procedure" should be done in a well ventilated area as follows.

1. Remove the Baffle Plate from the pallet and place it on shelving inside the stove. The shelving is located below the Heat Exchange Tubes. Make certain the Baffle plate is pushed all the way to the right hand side of the unit and not centered.
 2. Plug the stove into a grounded outlet. (Using a circuit tester verify the electrical outlet for proper ground and polarity where the unit will be installed. Failure to do so could result in damage to the electrical components and void the warranty.)
 3. Check the shutter on the Draft Fan and make sure it is set at 1/2 open. (once installed the actual setting will depend upon the draft of the flue.) On the Primary Control Board, A) set the Main Power Switch from "Stove Off" to the "Draft Fan" position and B) put the Fuel Feed Rate on "Full". The Draft Fan should now start. Open the door, place your hand over the Firepot and see if the Draft Fan is forcing air into the Firepot. Turn the Main Power Switch to the "Stove Off" position.
 4. Turn the Rheostat "On" to see if the Room Air Fan(s) run. After checking the fan(s), turn the Rheostat "Off".
 5. Look down into the Hopper, and make sure nothing is obstructing the Fuel Metering Cup. Pour 1/4 bag of pellets in the Hopper.
 6. With the Main Power Switch in the "Feed System" position, push the Start Button. Allow fuel to feed for approximately five minutes. Put the Main Power Switch in the "Stove Off" position. Apply non-volatile lighting material to the pellets and light it with a match. Let the fuel burn for five minutes leaving the door slightly ajar.
 7. Close the door and set the Main Power Switch to the "Feed System" position, and the Fuel Rate Switch to the "Full" position. Push the Start Button. The Draft Fan will run at high and the flame will increase (a full flame will need to be established in the Firepot before normal operation can be maintained).
 8. Once running, observe the stove operating for 15-30 minutes.
 9. As the stove temperature rises, the Room Air Fan(s) will automatically be engaged. Set the Rheostat to the desired speed.
 10. If necessary, adjust the Draft Fan Shutter to bring the fire to a bright yellow flame (approximately 1/2 open).
 11. Once the stove is operating properly, complete filling the Hopper and run the unit for 30 minutes.
-

CLEARANCES

The termination of the outside chimney of the pellet stove shall be located in accordance with the following:

1. Higher than 3 ft. above any forced air inlet (air conditioner, etc.) located within 10 ft.
2. Not less than 4 ft. below, 4 ft. horizontally from or 1 ft. above any gravity air inlet (door, window, etc.).
3. Not less than 2 ft. from an adjacent building and not less than 7 ft. above grade when located adjacent to the public sidewalks (access).

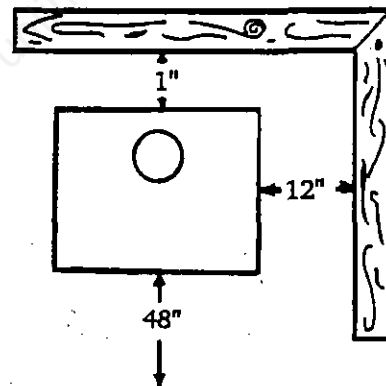
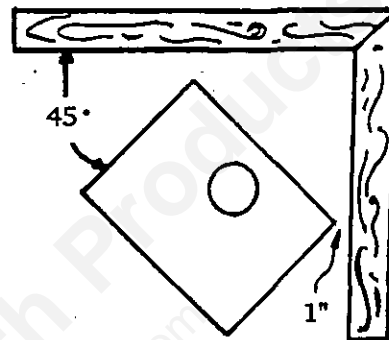

Minimum Clearances to Combustibles

Side: 12"
 Back: 1"
 Front: 48" horizontal from door

Single Wall pipe: 9"
 Maximum horizontal run: 36"
 Offsets allowed: 2

Floor Protection

If placing units on a combustible surface, floor protection is required in a residential installation. It is required for mobile homes. It is not required although, that the floor protection extend beyond the body of the stove.

INSTALLATION

Venting Requirements

There are several options for the installation and venting of your pellet stove. Refer to clearances before installing your stove.

Connect only one flue per appliance. When passing through walls or ceilings, The manufacturer recommends that clearances are maintained in accordance with NFPA 211. Do not downsize your connecting pipe or chimney.

Your NaturalFire pellet stove must be connected to a 4" pipe. UL listed pellet vent is a preferred type of pipe, or a single wall 26 gauge minimum. Follow the pipe manufacturers installation instructions and clearances. All pipe joints must be sealed with the compound supplied with the pipe or a RTV silicone with a rating of at least 570°F.

You may connect the single wall or pellet vent to the top of the stove using three screws to secure it to the collar. Use a RTV silicone with a rating of at least 570°F, or interam to provide a complete seal.

Direct Vent

Although a direct vent flue is an approved installation, the manufacturer does recommend that to eliminate the possibility of siding discoloration and/or to enhance performance in bad draw situations, the outside flue should be installed with a "T", and Pellet Vent chimney pipe run up through the eave. Terminate the pipe using the standard clearance. Exception: if using a UL listed Pellet Vent pipe you may use the Pellet Vent manufacturer's clearances.

If burning corn, direct vent is not an approved installation.

IMPORTANT!! Never turn the Draft Fan Selector to the "OFF" position on any direct vent installations. Keep the Combustion Fan Switch on the Primary Control Board in the "Low" or High" position. In the event of a loss of power in a rear vent direct termination application, natural draft is not present and you will experience smoking, but this will dissipate rapidly.

1. Remove the louvered panel to access the top vent outlet.
2. Place the cover plate (A) over this opening. Make sure the gasket (B) is in place and there is a complete seal. Replace bolts and tighten.
3. Remove the rear vent cover flange located on the back of the stove.
4. In its place, install the gasket (B) and starting collar (C) making sure the gasket center has been cut out to allow flue gas to pass through the collar. Replace bolts and tighten.
5. Attach section of pellet vent pipe (D). Seal this connection with high temperature silicone sealant. The horizontal run may not exceed 36 inches.

A rear breach kit is available through your dealer, part number RBK50. It consists of the A) top vent cover plate, and C) 4" starting collar.

- A) Top Vent Cover Plate
- B) Gasket Material
- C) 4" Starting Collar
- D) 4" - 24" section
- E) 4" Wall Thimble
- F) 4" Rain Cap

INSTALLATION

Direct Vent

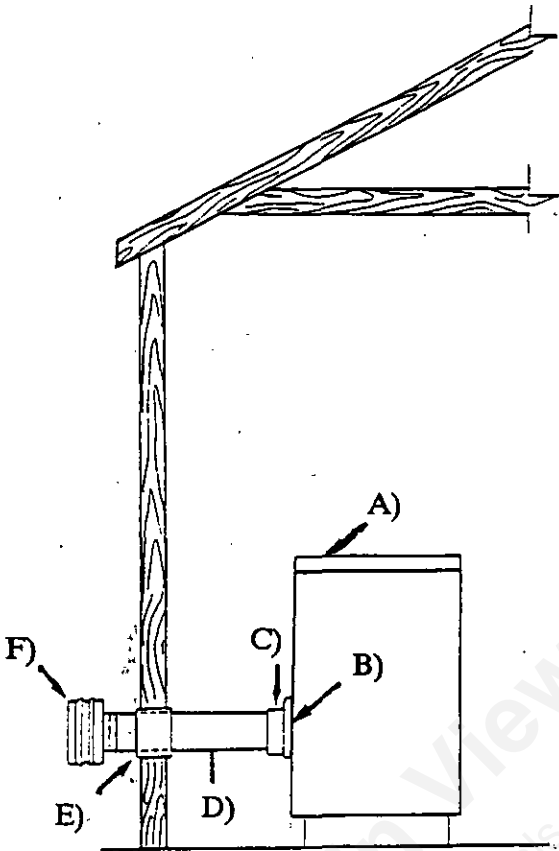

Connection To A Masonry Chimney Through A Wall

Be sure to verify the construction of a masonry chimney, as many have combustible framing. Follow the pipe manufacturer clearances.

An oversized chimney or high altitude may result in less than optimum performance. Installations into a large, masonry chimney may require a liner to improve performance. The use of single wall flex or rigid (26 gauge galvanized or stainless steel) pipe as a liner is approved.

Connection To An Existing Class A Chimney

You may use a single wall or pellet vent pipe from the stove top to chimney system. An adaptor can be used to make the connection from 4" pipe to existing UL chimney system. Verify with the pipe manufacturer that your pipe brands will interconnect. Installations into a large UL chimney system may require a liner to improve performance. The use of single wall flex or rigid (26 gauge galvanized or stainless steel) pipe as a liner through a UL class "A" chimney is approved.

Standard

The most desirable installation is Pellet Vent pipe connected to the top of the stove and run up through the ceiling, then terminating above the roof line. Be sure to follow all clearances listed by the pipe manufacturer.

INSTALLATION

Mobile Home Installation Requirements

Installation of the MP250 in a mobile home must follow the instructions for residential installation, with the following supplemental requirements:

1. No single wall pipe may be used. Pellet Vent pipe must be used from stove top to termination.
2. Offsets permitted: Maximum two offsets.
3. The chimney must provide for a section joint so that any parts extending above 13' 6" from ground level can be removed for transportation of the mobile structure.
4. The stove must be grounded to the mobile home trailer frame with a No. 8 (minimum) solid conductor.
5. The combustion air must communicate to the outside air.
6. Floor protection beneath the unit is required, but does not have to extend past the body of the stove.
7. Structural members such as roof trusses or floor joists cannot be cut or modified while making the installation.

Outside Air Provision

Although this section applies to a mobile home installation, it may also be required by local codes in standard residential installations. Use the manufacturer's optional outside air kit (part #85-35) or equivalent.

1. Set the stove in its installed position and select the floor or outside wall location for the outside air penetration. The air ducting must connect with the bottom of the motor cabinet of your stove, using rigid or flexible 3" duct.
2. Cut an opening for the outside air kit (Part #85-35).
3. Install the outside air kit.

INSTALLATION

Installation Applications

Direct Vent Termination

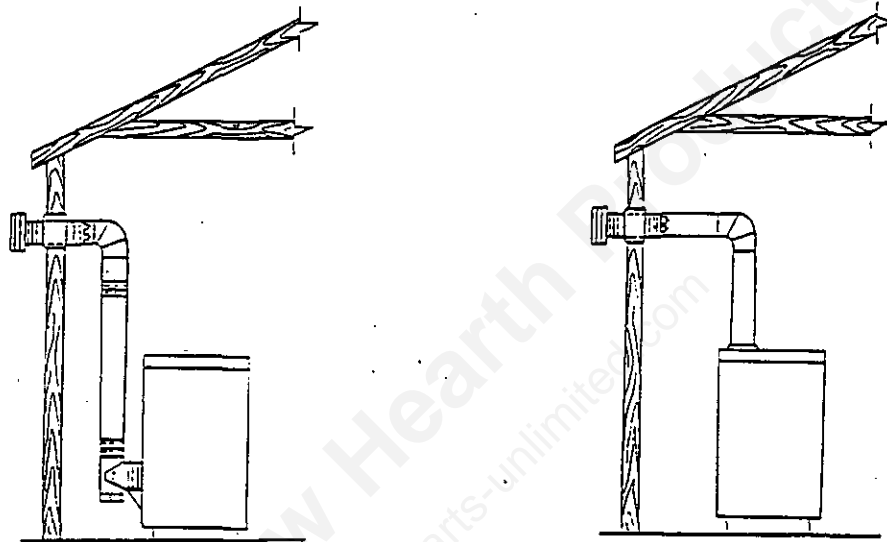

Direct Vent Using A "T"

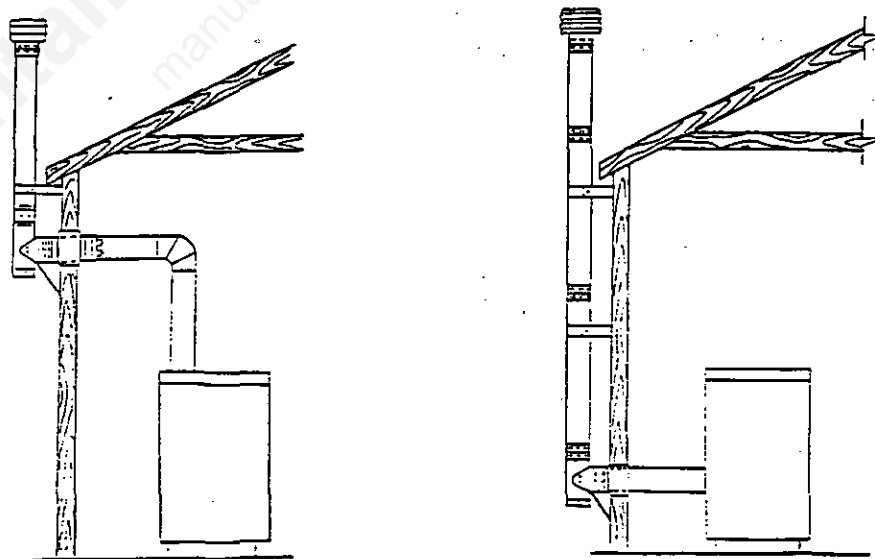

SIX STEP TROUBLESHOOTING GUIDE *(Qualified Technicians Only)*

Tools Essential For Troubleshooting

1. Stove Installation and Operation Manual.
2. Circuit Tester (Micronta # 22-101 or equivalent).
3. Molex Pin Extractor, 1/8" (p/n # 15068).
4. Volt Meter.

ATTENTION: Before attempting any troubleshooting; 1) Check your outlet to see that you do have power and the outlet is wired properly (use circuit tester); 2) Check the flue for blockage; 3) Take the time to clean the stove; 4) Note the model number of the primary control board (if a model number is not printed on the face of the primary control board, it is a model: Emerson.)

Step #1

Room Air Fan System Check

Turn the rheostat knob till it "clicks", it is now "ON". In this position the room air fan(s) will operate at full speed (115v). Place your hand in front of the air outlet to confirm that air is coming out. Further rotation of the knob will slow the speed of the room air fan(s). On the lowest setting the fan(s) receives approximately 65 volts. If the room air fan(s) comes on and operates properly (as described), the source of the problem will not be the rheostat, room air fan(s), fan speed disc, wiring connections or circuitry.

Should the room air fan(s) fail to come on, the first step in finding the problem is to check the power source (using a circuit tester or simply plug a lamp or other small appliance into the outlet). Once it has been determined that there is power to the outlet, the room air fan motor can be checked by removing the leads from the molex connector and connecting them to a 115v power source. If the room air fan(s) run, the problem is a loose connection. If the room air fan(s) fail to run, replacement will be necessary.

Step #2

Confirm Power to Primary Control Board

Turn main power switch from the "OFF" position to the "DRAFT FAN" position. If the red indicator light comes on, there is power to the primary control board. If the light does not come on, check the following:

- A. Power source (see Step #1)
- B. Fuse
- C. High limit manual reset discs
- D. High limit auto reset disc

If the fuse is not blown and the high limit manual reset disc has not "popped out", inspect the molex connectors and be certain the pins are making proper contact. Then, using a volt meter, check for power at the power switch. If the volt meter indicates 115v and the red indicator light is not on, it will be necessary to replace the primary control board.

Step #3 Confirm Draft Fan Operation

Set the main power switch to the "DRAFT FAN" position then set the fuel rate switch to the "FULL" position. The draft fan should now operate at full power (approx. 115v). During the piloting process, the draft fan will operate at the following speeds:

Switch Position	Voltage
High	70-75v
Low	60-65v
Off	0v

To check the draft fan when the stove is cold, check for movement of air by placing your hand in or near the firepot. If the movement of air is not obvious, inspect the draft fan to be certain the air shutter is open. If the air shutter is open and the draft fan is not running, check it by using the procedure in Step #1, paragraph 2.

Step #4 Inspect Fuel Metering Cup for Blockage

To inspect the fuel metering cup, **FIRST**:

- **UNPLUG THE POWER CORD.**
- **NEVER PUT YOUR FINGERS IN THE FUEL CAVITY OF THE METERING CUP.**

Remove all the fuel from the hopper. Reach down inside the hopper and rock the fuel metering cup back and forth (being careful not to put fingers in fuel cavity of metering cup). The cup should move approximately 1/4" in either direction. If it does not move, something is jamming it (usually a foreign object) and will have to be removed by using one of the following methods:

- A. Using a tool, such as a slotted screw driver, clear the obstruction (between the fuel cavity of the metering cup and the blade).

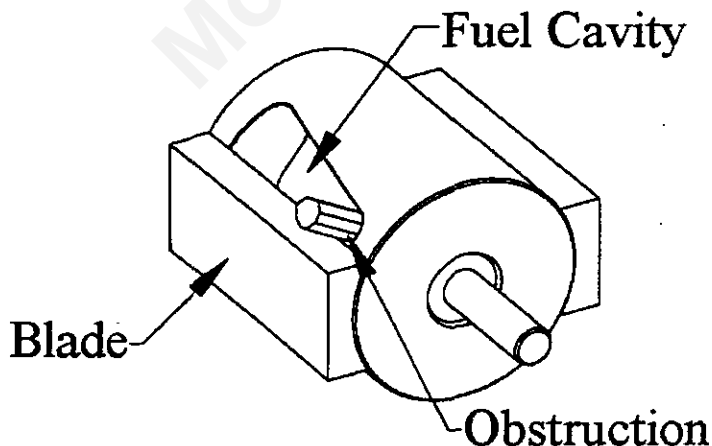

- B. Locate the metering cup motor cooling propellor on the back of the appliance and turn it by hand in the reverse direction until the metering cup rotates back far enough to clear the obstruction.
- C. If procedures A or B fails to clear the obstruction, then remove the metering cup motor and metering cup to find and clear the obstruction.

Step #5 Confirm Cup and Auger Motor Operation

Set the main power switch to the "FEED SYSTEM" position. Press the "START" button. Both the cup and auger motor should start. If the motors run but the fuel metering cup and/or auger does not turn, check the cast iron coupler on the ends of each motor shaft to make certain the set screw is tight on the flat part of the shaft. If the motors are not running, use a volt meter to check for line voltage (115v) at the molex connector or check them by using the procedure described in Step #1, paragraph 2.

Note: Anytime you are checking the motors, you should verify the speed at which the motors are turning. This can be accomplished by timing the revolution of the coupler. Using the set screw as a reference point, the bottom motor (auger) will make approximately one revolution in 10 seconds. The top motor (cup) will make approximately one revolution every 48 seconds.

Step #6 Re-light The Stove

Follow the normal start up procedure. If the unit fails to start, check to be certain the leads to the safety disc are attached.

POWER FLOW DIAGRAM

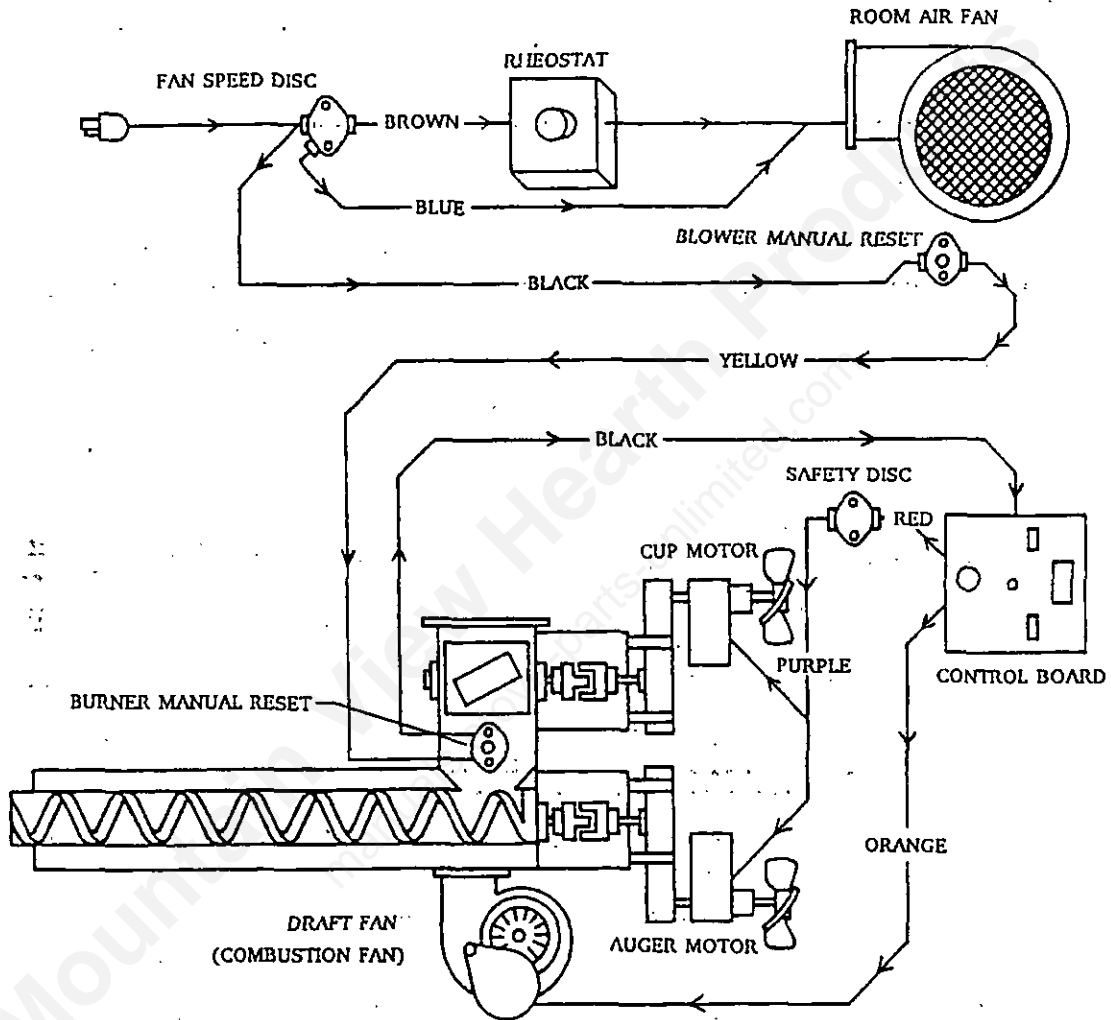

Glossary of Terms

AUGER The Auger transfers the fuel down the Burner Tube into the Firepot.

AUGER MOTOR The Auger Motor drives the Auger to deliver fuel to the Firepot.

BURNER TUBE The Burner Tube contains two passageways; one for the Auger and the other for combustion air. This tube supplies both the fuel and combustion air to the Firepot.

CUP MOTOR The Cup Motor drives the Fuel Metering Cup to deliver fuel to the Auger.

DRAFT FAN Pushes air into the Firepot for combustion and into the flue for draft.

FAN SPEED DISC At stove temperatures above 140°, the Fan Speed Disc activates by-passing the Rheostat causing the Room Air Fan(s) to run at full speed.

FIREPOT The Firepot is where combustion occurs.

FUEL METERING CUP The Fuel Metering Cup meters the amount of fuel and delivers it down to the Auger. The cup will deliver a set amount of fuel.

HOPPER The Hopper is where the pellets are stored and funneled down to feed the Fuel Metering Cup.

MAIN POWER SWITCH The Main Power Switch is the main switch allowing electricity to flow through the Primary Control Board to the components.

MANUAL RESET If the temperature of the stove reaches 200°F, the Manual Reset will "POP" and stop the flow of electricity to the fuel feed system.

MOTOR CABINET Covers the Fuel Feed and Burner System components.

SAFETY DISC At stove temperatures above 120°, the Safety Disc engages to allow electricity to flow to the fuel feed system.

RHEOSTAT At stove temperatures below 140°F, the Rheostat can be used to vary the speed of the Room Air Fan(s).

SPECIFICATIONS

Approx Sq Ft Heat Capacity	Up to 1800 Sq. Ft.
Flue size	4" Top or Rear
Width	25.5"
Depth Overall	37.5"
Height (w/flue collar)	35.5"
Height	33.50"
Bk/Hopper Cntr of Flue	19.5"
Floor to Rear Flue Center	12.75"
Outside Air Provision	Yes
Floor Protection Requirements	
Mobile Home	Yes
Residential	Yes
Fuse	3 amp
Hopper Capacity	40 lbs
Heat Input (maximum)	50,000 BTU/hr
Ship Weight	350 Lbs.
Room Blower (2 ea.)	160 CFM (ea) .9 amps
Cup Motor	Approx 1 RPM .34 amps
Auger Motor	Approx 6 RPM 1.12 amps
Draft Fan	Approx 60 RPM .65 amps

~ Square feet heating capacities are approximations only. They will vary depending upon the level of insulation, climate, house design, ceiling height, ambient outside temperatures and how the stove is operated.

COMPONENT DIAGRAMS

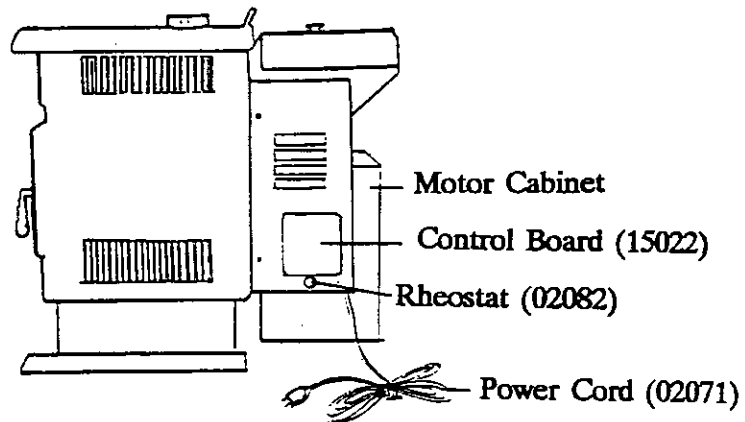
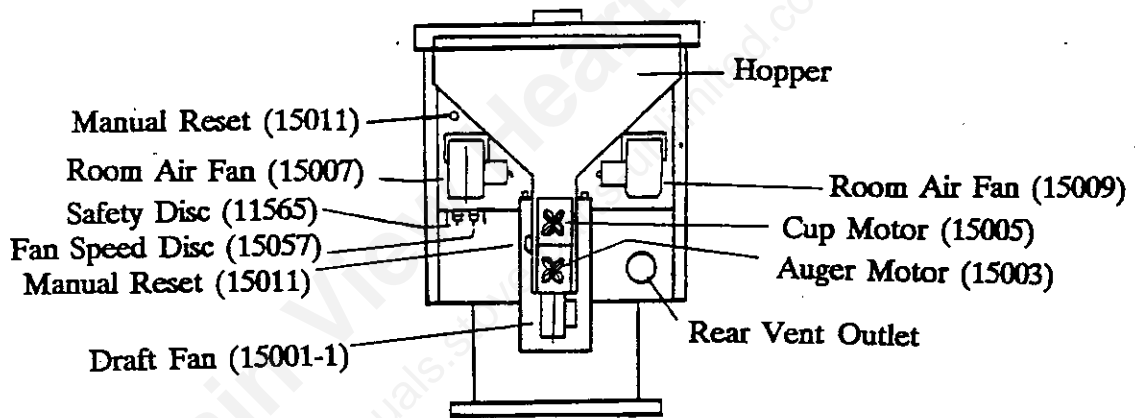
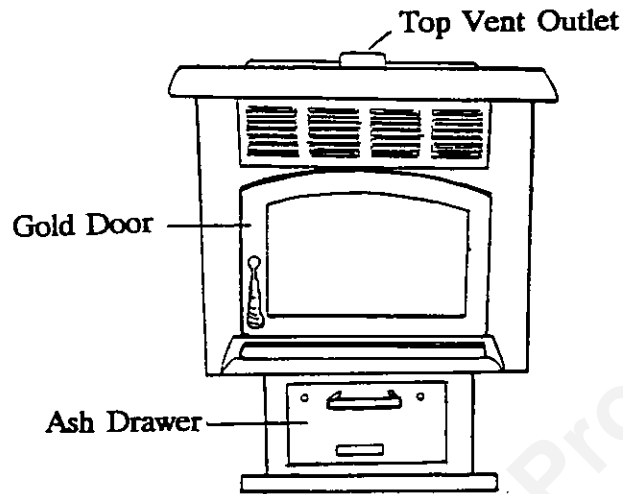

NaturalFire™ Limited Warranty

To the ORIGINAL PURCHASER of an appliance during the period of warranty coverage stated below, the manufacturer warrants the appliance to be free of defects in material and workmanship. This warranty gives you specific rights and you may have other rights which vary from state to state. Some states MAY NOT ALLOW the limitations or exclusions set forth below SO THE LIMITATIONS OR EXCLUSIONS MAY NOT APPLY TO YOU.

ALL PARTS are warranted 100% for one year from date of purchase for any defects in materials or workmanship.

ELECTRICAL PARTS are warranted for two years from date of purchase for any defects in materials or workmanship. The second year coverage is pro-rated at 50%, based on the current retail price.

ALL PARTS EXCEPT electrical components, logs, glass, gaskets, firepots, baffles and paint are warranted for five years from date of purchase for any defects in materials or workmanship. Pro-rated coverage for years two through five is as follows:

Year 2	80% coverage
Year 3	60% coverage
Year 4	40% coverage
Year 5	20% coverage

All pro-rated warranty coverage during years two through five is based on the then current retail price.

This appliance MUST BE INSTALLED BY A QUALIFIED INSTALLER in accordance with instructions furnished with your appliance.

No repair or replacement costs will be reimbursed without the PRIOR APPROVAL of the manufacturer or the manufacturer's authorized dealer. Approval is obtained by returning the defective part, at PURCHASERS EXPENSE, to the manufacturer's authorized dealer for inspection prior to repair or replacement. This warranty DOES NOT include or cover the cost of inspection or labor involved in removing or replacing a defective part, all of which must be borne by the purchaser.

This warranty is limited to defects in material and workmanship, and it does not apply to loss or damage which is the result of accident, misuse, negligence, improper installation or any other cause occurring after delivery to the ORIGINAL PURCHASER. No person is authorized to extend or enlarge any liability or obligation which we may have in connection with the sale of this appliance.

All other warranties, expressed, implied or statutory, including warranties of fitness for a particular purpose of merchantability are conditioned upon compliance with the following terms and are LIMITED TO a period ending ONE YEAR after the original retail purchase after which there are no remedies which extend beyond the description on the face hereof.

WE SHALL NOT BE LIABLE FOR INCIDENTAL OR CONSEQUENTIAL DAMAGES OR COMMERCIAL LOSS, NOR FOR ANY OTHER LOSS OR DAMAGE EXCEPT AS SET FORTH ABOVE.

IMPORTANT: This warranty is not valid unless the warranty registration card has been properly completed and mailed within 30 days of the date of purchase.

For your records:

Date Purchased: _____ Authorized Dealer: _____
Model Number: _____ Serial Number: _____

The Earth Stove, Inc.
10595 S.W. Manhasset Street
Tualatin, OR 97062

Mountain View Hearth Products
manuals.stove-parts-unlimited.com