



WARRANTY REGISTRATION  
enviro.com/warranty

# Kodiak 1200 FS & Kodiak 1700 FS

## FREESTANDING WOOD STOVE

# OWNER'S MANUAL



PLEASE READ THIS ENTIRE MANUAL BEFORE INSTALLATION AND USE OF THIS WOOD BURNING ROOM HEATER. FAILURE TO FOLLOW THESE INSTRUCTIONS COULD RESULT IN PROPERTY DAMAGE, BODILY HARM, OR EVEN DEATH.

CONTACT YOUR BUILDING OR FIRE OFFICIALS ABOUT RESTRICTIONS AND INSTALLATION INSPECTION REQUIREMENTS IN YOU AREA.

THIS HEATER MEETS THE 2015 U. S. ENVIRONMENTAL PROTECTION AGENCY'S CRIB-WOOD EMISSION LIMITS FOR WOOD HEATERS SOLD AFTER MAY 15, 2015. UNDER SPECIFIC CONDITIONS THIS HEATER HAS BEEN SHOWN TO DELIVER HEAT AT RATES RANGING FROM 11,479 TO 34,196 BTU PER HOUR FOR THE 1200 AND FROM 9,425 TO 31,780 BTU PER HOUR FOR THE 1700. THESE STOVES HAVE BEEN CERTIFICATION TESTED TO STANDARDS UL-1482-11 AND ULC-S627-00. CERTIFICATION TESTING COMPLETED BY OMNI-TEST LABORATORIES.

Tested &  
Listed By



Portland  
Oregon USA

OMNI-Test Laboratories, Inc.  
Report/Rapport No.  
268-S-04b-2, 268-S-01b-2

 Version Française: [www.enviro.com/fr.html](http://www.enviro.com/fr.html)

**INSTALLER:** LEAVE THIS MANUAL WITH THE WOOD STOVE.

**CONSUMER:** RETAIN THIS MANUAL FOR FUTURE REFERENCE.

**50-2920**

# TABLE OF CONTENTS

---

Safety Precautions.....	3
Efficiencies and Emissions.....	4
Operating Instructions.....	5
Building Your Fire.....	7
Air Control.....	10
How It Works.....	11
Specifications.....	12
1200 Specifications.....	12
1700 Specifications:.....	13
Clearances To Combustibles - 1200 Freestanding.....	14
Clearances To Combustibles - 1700 Freestanding.....	15
Dimensions - 1200 Freestanding.....	16
Dimensions - 1700 Freestanding.....	17
Freestanding Side Dimensions For Fan Kit.....	18
Installation.....	19
Removal From Pallet.....	19
Pedestal Installation - Freestanding:.....	19
Legs And Ash Pan Installation - Freestanding.....	20
Installation Of Heat-Efficiency Shield - Freestanding Flat Top.....	20
Hearth Protection Examples.....	21
Outside Air Kit.....	24
Recommended Heights And Diameters For Flue Pipe.....	24
Chimney Installation Through Wall.....	25
Installation of A Listed, Factory Built Chimney - Freestanding.....	26
Masonry Chimney Installation - Freestanding.....	28
Masonry Fireplace Installation - Freestanding.....	29
Mobile Home Installation.....	29
Model 1200 Brick Placement & Tube Locations.....	31
Model 1700 Brick Placement & Tube Locations.....	32
C-Cast Ceramic Baffle Installation.....	33
Fan Wiring Diagrams.....	33
Optional Fan Installation - Freestanding.....	34
RatingLabel.....	35
Parts List.....	36
Parts Diagram - Freestanding.....	38
Parts Diagram - Pedestals & Legs.....	39
Notes.....	40
Warranty.....	43
Installation Data Sheet.....	44

# SAFETY PRECAUTIONS

**PLEASE READ THIS ENTIRE MANUAL BEFORE YOU INSTALL AND USE OF YOUR NEW WOOD STOVE. FAILURE TO FOLLOW INSTRUCTIONS MAY RESULT IN PROPERTY DAMAGE, BODILY INJURY OR EVEN DEATH. BE AWARE THAT LOCAL CODES AND REGULATIONS MAY OVERRIDE SOME ITEMS IN THIS MANUAL. PLEASE CHECK WITH YOUR LOCAL BUILDING OR FIRE AUTHORITY.**

- This appliance becomes extremely hot when in use and can cause burns if contacted.
- Young children should be carefully supervised when they are in the same room as the appliance.
- Make sure you have incorporated proper safety measures to protect infants/toddlers from touching hot surfaces.
- Even after the appliance is out, the firebox and glass will remain hot for an extended period of time.
- If this appliance is not properly installed, operated, and maintained a serious house fire could result.
- Installation of appliance must be completed by a certified installer.
- Wear protective gloves and safety glasses during installation, sheet metal edges may be sharp.
- Do not operate without fully assembling all components.
- Do not use any makeshift materials during installation, maintenance, or replacement.
- Any changes or alterations to this appliance are dangerous and prohibited.
- This appliance has been designed to burn dried and seasoned hardwoods.
- Do not use chemical fluids to start or re-fresh the fire.
- Do not burn coal, charcoal, or treated wood as there is danger of carbon monoxide being produced.
- Do not burn garbage or flammable fluids such as gasoline, grease, naphtha or engine oil.
- Never let the stove become hot enough to get any part glowing red.
- Do not operate with door open, door must be tightly closed.
- Do not strike or slam shut the ceramic glass door, if the door glass is broken or a gasket is missing or damaged appliance must be repair by a qualified service technician before resuming use.
- At least 12 square inches (77.4 cm<sup>2</sup>) of fresh outside air should be admitted into the room or directly to the stove through a 4 inch (10.16 cm) diameter pipe.
- Do not burn wet unseasoned wood, this can causes excessive creosote accumulation. When this is ignited it can cause a chimney fire that may result in a serious house fire.
- Do not use grates, andirons or any other methods to support or raise the fire up off the fire bricks.
- Do not place clothing, furniture, draperies, or any other flammable materials on or near the appliance.
- Objects placed in front of the appliance must be kept at least of 48" away from the front face of the appliance.
- Do not connect appliance to a chimney flue pipe servicing another solid fuel burning appliance.
- Do not install in a mobile home this appliance is not Certified for that application.
- Do not attach to any kind of heat distribution ducting system.
- The chimney must be sound and free of cracks. Clean your chimney a minimum of twice a year and as required.
- Your appliance requires periodic maintenance and cleaning. Failure to maintain your appliance may lead to smoke spillage in your home.
- A chimney connector shall not pass through an attic, roof space, floor, ceiling, closet or similar concealed space.
- Do not store wood within appliance installation clearances or within the space required for refueling and ash removal.
- Ashes must be disposed in a metal container with a tight lid and placed on a non-combustible surface well away from the home or structure until completely cool.
- Ensure proper clearances to combustibles are maintained when building a mantel or shelves above the appliance.

**IMPORTANT: The following must be done to ensure proper operation. Failure to do so will cause extreme overheating and possible personal injury or property damage. If an outside air supply has not been added to this appliance, please ensure that the 4" inch fresh air inlet on the back of the pedestal is removed. Also ensure the ash plug is installed in the firebox.**



We recommend that our woodburning hearth products be installed and serviced by professionals who are certified in the U.S. by the National Fireplace Institute® (NFI) as NFI Woodburning Specialists or who are certified in Canada by Wood Energy Technical Training (WETT).



# EMISSIONS AND EFFICIENCIES

---

## EMISSIONS AND EFFICIENCY - 1200-K:

---

### KODIAK 1200

**Rates:** This manual describes the installation and operation of the Enviro Kodiak 1200 wood heater. This heater meets the 2015 U.S. Environmental Protection Agency's wood emission limits for wood emission limits sold after May 15, 2015. Under specific test conditions this heater has been shown to deliver heat at rates ranging from 11,500-34,000 Btu/hr.

**Efficiency:** 71.6%

## EMISSIONS AND EFFICIENCY - 1700-K:

---

### KODIAK 1700

**Rates:** This manual describes the installation and operation of the Enviro Kodiak 1200 wood heater. This heater meets the 2015 U.S. Environmental Protection Agency's wood emission limits for wood emission limits sold after May 15, 2015. Under specific test conditions this heater has been shown to deliver heat at rates ranging from 9,400-32,000 Btu/hr.

**Efficiency:** 75%

### **Stress Lines:**

Stress lines located within the firebox at the secondary air channels may result from the repeated expansion and contraction of metal during regular use. These lines, when narrower than the thickness of a coin, do not compromise the safety or efficiency of the unit and as such do not necessitate repair or replacement.

Similarly, stress lines that may appear on the firebox front due to regular use also do not compromise safety or efficiency of the unit, with the possible exception of the door gasket. In the event that these extend beyond the door gasket, they may have a minor effect on the integrity of the seal and will then be covered by the warranty policy for repair.

**WARNING:** This wood heater needs periodic inspection and repair for proper operation. It is against federal regulations to operate this wood heater in a manner inconsistent with operating instructions in this manual.

**WARNING:** This wood heater has a manufacturer set minimum low burn rate that must not be altered. It is against federal regulations to alter this setting or otherwise operate this wood heater in a manner inconsistent with operating instructions in this manual.

# OPERATING INSTRUCTIONS

## **FIRST START**

When first installed, the chimney, firebricks and steel are cold and it usually takes several hours on a fairly high burn for them to become hot and dry enough for the stove to function well. We recommend during the unit's first burn that a door and window are opened to vent the smoke and fumes created from the unit's paint curing. The paint will smell a little for the first burn or two as it cures.

## **DISPOSAL OF ASHES:**

If you let the ashes accumulate two or three inches on the floor they tend to burn themselves up.

The fireplace insert models do not have an ash drawer so the ashes will need to be scooped into a metal container with a tightly fitting lid. Place the closed container on a non-combustible floor, well away from combustible materials.

The freestanding models are equipped with a small trap door in the firebox and an ash drawer. Open the trap door located on the floor of the unit. Push the ashes that have accumulated into the hole where the ashes would drop into the ash pan. Ensure that the trap door is closed properly before relighting the unit. When the ash drawer is ready to be emptied lift the front of the drawer up then slowly pull the drawer straight out and close the lid on the ash drawer (see Figure 1); this is to prevent making a mess with the ashes when transporting the ash drawer through the house. When re-installing the ash drawer ensure that the lid is open and line up the rails on the bottom of the ash drawer with the notches in the opening on the pedestal (see Figure 2). Slide the drawer into place, the front of the drawer will drop a bit when it is all the way in.

If the ashes are to be buried in soil or otherwise locally dispersed, keep them in a closed container until all cinders have cooled. Small amounts of cold wood ash can be used in the garden or compost.

## **FAN OPERATION:**

All models have been approved for operation with or without the optional fans supplied by the manufacturer. On medium or high burns, using a fan will increase the heat transfer slightly. Route the power supply cord along the floor behind the stove where it will remain cool.

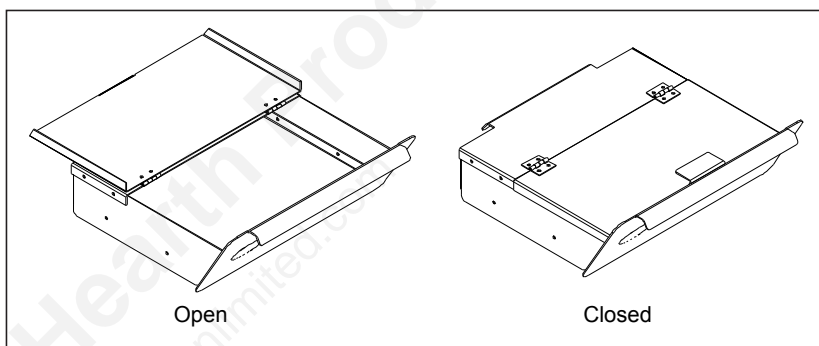

**Figure 2: Ash Drawer Lid Open and Close.**

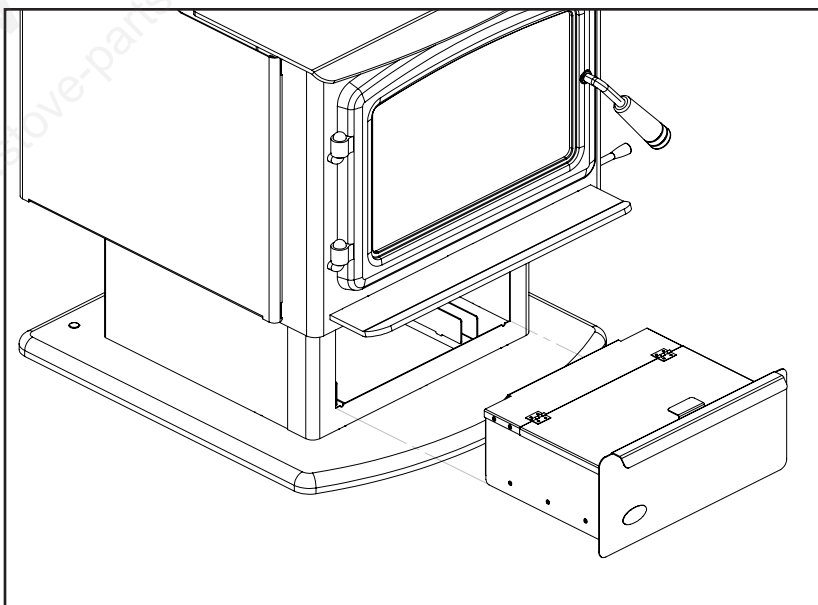

**Figure 3: Installing Ash Drawer.**

# OPERATING INSTRUCTIONS

---

1. Plug the fan assembly into a standard three (3) prong grounded electrical receptacle.
2. Freestanding - turn the rotary fan controller to the desired setting.

Inserts - an auto/off/manual rocker switch allows the fan to be turned on manually, or automatically.

When this switch is pushed right toward the unit, it will be set to manual operation; the center position is off, and when pushed left away from the unit, it will be set to automatic.

3. In automatic mode (& for freestanding units), set the rotary switch to the desired setting, once operating temperature is reached, the fan temperature sensor will turn the fan on. When the unit cools down, the fan temperature sensor will shut the fan off automatically.
4. In manual mode (Inserts only) the fan can be turned on and off any time using the rotary switch.

## **REPLACING THE GLASS:**

Never strike or slam the door, hit the glass or let burning wood rest against it. If the glass cracks when the fire is burning, do not open the door until the fire is out and do not operate the stove again until the glass has been replaced. If the glass is damaged in any way, a factory replacement is required (see "PARTS LIST"). To remove the door, open and lift. To replace the glass, remove the steel retaining clips and all loose glass. Replace only with Neoceram 5 mm glass 16.61" (422 mm) x 10.63" (270 mm) and wrap the edges with 0.125" (3.2 mm) x 0.5" (13 mm) self-adhesive fiberglass gasket.

Wear gloves when handling damaged glass door assembly to prevent personal injury. When the glass door assembly is being transported, it must be wrapped in newsprint and tape and/or a strong plastic bag.

**The glass must be purchased from an ENVIRO dealer. No substitute materials are allowed.**

## **CLEANING THE PLATED SURFACES:**

Painted faces should be wiped with a damp cloth periodically. If a plated door has been purchased, it should be unpacked carefully to avoid getting anything on the surface of the finish, including cleaners, polish and finger prints. It is important to note that fingerprints and other marks can leave a permanent stain on plated finishes. **To avoid this, give the face a quick wipe with denatured alcohol on a soft cloth BEFORE lighting the fireplace.** Never clean the door when it is hot. Do not use other cleaners as they may leave a residue, which can become permanently etched into the surface.

## **FIRE EXTINGUISHER AND SMOKE DETECTION:**

All homes with a wood burning stove should have at least one fire extinguisher in a central location known to all in the household. Smoke detectors and carbon monoxide detectors should be installed and maintained in the room containing the stove. If it sounds the alarm, correct the cause but do not deactivate. You may choose to relocate the smoke detection device within the room; **DO NOT REMOVE THE SMOKE OR CARBON MONOXIDE DETECTORS FROM THE ROOM.**

## **CREOSOTE - ITS FORMATION AND REMOVAL:**

When wood is burned slowly, it may produce tar and other vapors that, combined with moisture, form creosote. These vapors condense in the relatively cooler chimney flue of a slow burning fire and, if ignited, make an extremely hot fire. Therefore, the smoke pipe and chimney should be inspected biweekly during the heating season to determine if a build-up has occurred. If creosote has accumulated it should be removed to reduce the risk of a chimney fire.

## **MAINTENANCE:**

At the end of each heating season clean the chimney and the smoke pipe. If soot has accumulated above the top baffle bricks, remove, clean, and then replace them. If the secondary air tube is badly eroded, replace it. Replace worn door gaskets and broken bricks as needed.

# OPERATING INSTRUCTIONS

---

**FAILURE TO INSPECT AND CLEAN YOUR CHIMNEY SYSTEM REGULARLY CAN RESULT IN A CHIMNEY FIRE, WHICH COULD DAMAGE THE CHIMNEY OR CAUSE A HOUSE FIRE.**

## **CHIMNEY OR RUN AWAY FIRE:**

1. Call local fire department (or dial 911)
2. Close the draft fully
3. Examine the flue pipes, chimney, attic, and roof of the house, to see if any part has become hot enough to catch fire. If necessary, spray with fire extinguisher or water from the garden hose.
4. Do not operate the stove again until you are certain the chimney and its lining have not been damaged.

## **BUILDING YOUR FIRE:**

---

Proper operation of your stove will help to ensure safe, efficient heating. Please take a few moments to review these simple operating procedures.

**IMPORTANT:** Please be aware when loading your stove that the air tubes in the rear are lower.

### **1. Fuel Selection:**

This stove is designed to burn natural wood only. Higher efficiencies and lower emissions generally result when burning air-dried seasoned hardwoods, as compared to softwoods or to green or freshly cut hardwoods. **DO NOT BURN** the following: treated wood, coal, garbage, solvents, colored papers, or trash. Burning these may result in the release of toxic fumes and may poison or render the catalytic ineffective. Burning coal, cardboard, or loose paper can produce soot, or large flakes of char or fly ash that can coat the combustor, causing smoke spillage into the room, and rendering the combustor ineffective.

### **2. Building/Maintaining a Fire:**

- a) Open the primary air slide by pulling it all the way to the right.
- b) Place a base of crumpled uncolored newspaper in the bottom of the stove. Lay pieces of kindling on top of the newspaper and light it.

**CAUTION: Never use gasoline, gasoline-type lantern fuel, kerosene, charcoal lighter fluid, or similar liquids to start or "freshen up" a fire in this heater. Keep all such liquids well away from heater while it is in use.**

- c) As the kindling begins to burn, add several larger pieces of wood until the fire is burning well. At this point, regular size logs may be added.

**CAUTION: Never allow the fire to rest directly on the glass. Space the logs at least one inch off the glass to allow for proper air flow.**

**NOTE:** Until the fire is burning well, leave the air controls fully open.

- d) Regulate the heat output of the stove by adjusting the air controls to allow a larger fire and vice versa. A short period of experimentation with the control settings will allow you to regulate the heat output to keep your home comfortable.

**Do not use a grate or elevate the fire. Build wood fire on the stove firebox hearth floor.**

### **3. Refueling the Stove:**

Use a long pair of gloves (barbecue gloves) when feeding the fire because these stoves burn at the front. They are clean and efficient but they are also very hot and gloves are useful. Keep a small steel shovel and whisk nearby for moving a log or lifting a fallen ember and for keeping the hearth clean.

# OPERATING INSTRUCTIONS

---

- a) Before attempting to add fuel to the stove, OPEN the damper control fully by pulling it all the way out. This allows the chimney to carry away the additional smoke, which occurs when the door is open.
- b) **DO NOT OVERLOAD THE STOVE.** Normally, three or four logs will provide heat for several hours. Never operate this stove where portions glow red hot. Using more than five logs at a time can cause overfiring. Keep logs a few inches from the lowest point of the top of the firebox. If any logs are touching the tubes in the top of the firebox, you can damage the air tubes. Overloading the stove can cause damage to the firebox and air tubes and will void the warranty.
- c) **DO NOT OVERFIRE.** If the heater or chimney connector glows, you are overfiring. If the stove top temperatures exceed 550°F, you are overfiring. Overfiring your stove will void the warranty.
- d) **WHAT IS OVERFIRING?** Overfiring is when the stove is generating too much heat in the firebox, causing parts within your stove to glow red and warp. To spot overfiring, place a thermometer on the stove top. If the stove top temperatures exceed 550°F, you are overfiring. Another way to spot overfiring is if the heater or chimney connector glows.
- e) **CAUTION: DO NOT PLACE FUEL OR COMBUSTIBLE MATERIAL WITHIN SPACE HEATER INSTALLATION CLEARANCES OR WITHIN THE SPACE REQUIRED FOR CHARGING AND ASH REMOVAL. LOGS SHOULD BE KEPT IN A BIN OR CONTAINER TO REDUCE THE RISK OF LOGS ROLLING INTO THE UNIT'S CLEARANCES.**
- f) **HOW TO AVOID OVERFIRING:** To avoid overfiring, do not overfill your firebox. Usually a maximum of four logs at a time is sufficient enough to avoid overfiring. Keeping stove top temperatures under 550°F will also prevent overfiring.
- g) **KEEP THE ASH LIP CLEAR OF EMBERS AND ASH.** If the door is closed with debris in the way, the door gasket seal could be compromised.

## 4. For Maximum Efficiency:

When the stove is hot, load it fully to the top of the door opening and burn at medium low settings. When the fuel is mostly consumed, leaving a bed of red coals, repeat the process. Maximum heat for minimum fuel occurs when the stove top temperature is between 250°F (120°C) and 550°F (290°C). The most likely causes of dirty glass are: not enough fuel to get the stove thoroughly hot, burning green or wet wood, closing the draft until there is insufficient air for complete combustion, or a weak chimney draw. Indeed, the cleanness of the glass is a good indicator of the stove operating efficiently.

## Helpful Hints Worth Repeating

### 1. Helpful advice on the correct way to start your fire.

- a) You will need small pieces of dry wood, called kindling, and paper. Use only newspaper or paper that has not been coated or had other materials glued or applied to it. Never use coated (typically advertising flyers) or coloured paper.
- b) Always open the door of the wood stove slowly to prevent suction and drawing smoke into the room.
- c) Crumple several pieces of paper and place them in the center of the firebox and directly onto the firebricks of the wood stove. Never use a grate to elevate the fire.
- d) Place small pieces of dry wood (kindling) over the paper in a "teepee" manner. This allows for good air circulation, which is critical for good combustion.
- e) Light the crumpled paper in 2 or 3 locations. Note: It is important to heat the air in the stovepipe for draft to start.
- f) Fully open the air controls of the wood stove and close the door until it is slightly open, allowing for much needed air to be introduced into the firebox. Never leave the door fully open, as sparks from the kindling may fly out of the stove, causing damage or injury. As the fire begins to burn the kindling,

# OPERATING INSTRUCTIONS

---

some additional kindling may be needed to sustain the fire. DO NOT add more paper after the fire has started.

- g) Once the kindling has started to burn, add some smaller pieces of seasoned, dry firewood. Note: Adding large pieces at the early stages will only serve to smother the fire. Continue adding small pieces of seasoned dry firewood, keeping the door slightly open until each piece starts to ignite. Remember to always open the door slowly between placing wood into the fire.
- h) Once the wood has started to ignite and the smoke has reduced, close the wood stove door fully. The reduction of smoke is a good indication that the draft in the chimney has started and good combustion is now possible. Larger pieces of seasoned, dry firewood can now be added when there is sufficient space in the firebox. Adjust the air control setting to desired setting. Note: The lower the air control setting, the longer the burn time of your firewood.

## **2. What type of wood is best to use as firewood?**

Both hardwood and softwood burn well in this stove. Both woods contain about 8,000 BTU/lb (18,570 KJ/Kg), but hardwood is generally more dense, will weigh more per cord, and burns a little slower and longer. Cutting firewood so that it will fit horizontally, front to back, makes it easier loading and less likely for the fuel to roll on the glass. Except for a cold start, there is no need to crisis-cross the logs. Ideal length for the logs used in the 1200 would be about 16" (381 mm) but it can burn pieces up to 18" long. Ideal length for the logs used in the 1700 would be about 18" (381 mm) but it can burn pieces up to 20" long logs. Burn only dry, seasoned wood. It produces more heat and less soot or creosote. Freshly cut wood has about 50% moisture. A 10 pound (4.5 Kg) log contains 5 pounds (2.3 Kg) of water. To season firewood, split and stack it so that air can get to all parts of the wood. Burn beach wood only if its salt content has been washed away in a season of rain and then the wood dried. To prevent smoke spillage when refueling, open the door slowly.

## **3. What does dry, seasoned wood mean?**

Wood that has been dried for a period of one year in a well-ventilated and sheltered area would be considered dry, seasoned wood. Wood from slow-growing trees is generally considered better than wood from fast-growing trees. To season firewood, split and stack it so that air can get to all parts of the wood.

## **4. Will following the above-listed steps for starting a fire mean perfect results every time?**

The quick answer is 'most of the time'. There are many variables that may affect your success when starting a fire. Most of those variables and how to deal with them will be learned through experience. Your ability to start a good fire will significantly increase with time and patience. Some of the reasons for poor stove performance will be covered in the next section of these instructions.

## **5. Why can't I get the fire lit?**

Damp or wet wood and poor drafts are the main reasons for poor results in starting a fire. Always use dry, seasoned wood for your fire. Even wood dried for two years will be difficult to ignite if it has become wet.

## **6. Is it normal for soot to cover the glass at the beginning of a fire?**

Your stove has been built with an air-wash system that will help keep the glass clear when the firebox has reached a good operating temperature and has a good draft. Normally a hot stove will keep the glass clean, but if you must clean the glass, use a soft cloth with no abrasive and clean only when cold. Cold firebox temperature and poor draft cause sooting of the glass. Once the firebox temperature and the draft increase, the soot will burn off. **Do not use abrasive cleaners on glass.**

## **7. What is draft?**

Draft is the ability of the chimney to exhaust or draw smoke produced during the normal combustion process. Too much draft may cause excessive temperatures in the appliance and may damage the appliance. Inadequate draft may cause backpuffing or "plugging" of the chimney. There is a certain

# OPERATING INSTRUCTIONS

amount of draft that is required to allow for your stove to function at its' highest efficiency. A water column gauge can be used to reference this amount.

## 8. What can cause a poor draft?

The most common factors for poor draft are:

- a) Air supply
  - b) Environmental conditions
  - c) Cold chimney temperature
  - d) Poor chimney installation and maintenance
  - e) Atmospheric pressure
- a) Air supply – Inside the home, normal household appliances such as clothes dryers and forced-air furnaces compete for air, resulting in air starvation to the fire. This creates a condition in the house known as negative pressure. When a house experiences negative pressure, the combustion gases can be drawn from the chimney and into the house. This condition is commonly referred to as down-drafting. Increased amounts of insulation, vinyl windows, extra caulking in various places and door seals can all keep heat in but may also make a home too airtight. An easy way to stop negative pressure in a home is to crack a window in the room containing the stove.
  - b) Environmental Conditions - High trees, low-lying house location such as in a valley, tall buildings or structures surrounding your house and windy conditions can cause poor draft or down-drafting.
  - c) Cold Chimney Temperature - Avoid cold chimney temperatures by burning a hot fire for the first fifteen to forty minutes, being careful not to over-fire the stove. If any part of the chimney or parts of the stove start to glow, you are over-firing the stove. Where possible, install a temperature gauge on the chimney so temperature drops can be seen.
  - d) Chimney Installation and Maintenance - Avoid using too many elbows or long horizontal runs. Too short a chimney can cause difficult start-up, dirty glass, back smoking when door is open, and even reduced heat output. Too tall a chimney may prompt excessive draft, which can result in very short burn times and excessive heat output. If in doubt, contact a chimney expert and/or chimney manufacturer for help. Clean chimney, rain caps and especially the spark arrestor regularly, to prevent creosote build-up, which will significantly reduce chimney draw and possibly a chimney fire.

**Note:** These instructions are intended as an aid and do not supercede any local, provincial or state requirements. Check with officials or authorities having jurisdiction in your area.

## AIR CONTROL:

The air wash and pilot air (control the amount of air to the fire) are controlled by the rod located on the right side of the unit. To increase your air, pull the rod out and to decrease, push the rod in. All the units have a secondary air that flows through the tubes at the top of the firebox, just below the baffles.

Pull this control all the way out when first starting the stove. Once the fire has been established you may adjust this control to set the burn rate of the fire. If this damper is closed at first start-up, the fire will burn very slowly and could soot the appliance.

When shutting down the stove, fully open the air control. This allows the chimney temperatures to remain as high as possible for as long as possible. Cold chimney temperatures create creosote. If all of these steps are followed, there should be no visible emissions.

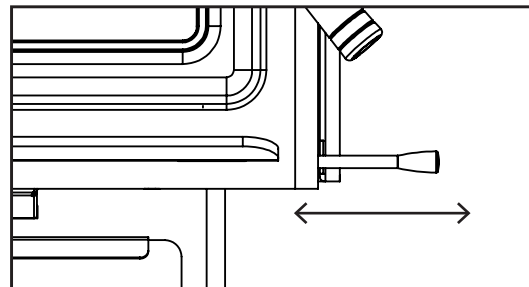

Figure 4: Air Control Rod.

# OPERATING INSTRUCTIONS

## How It Works:

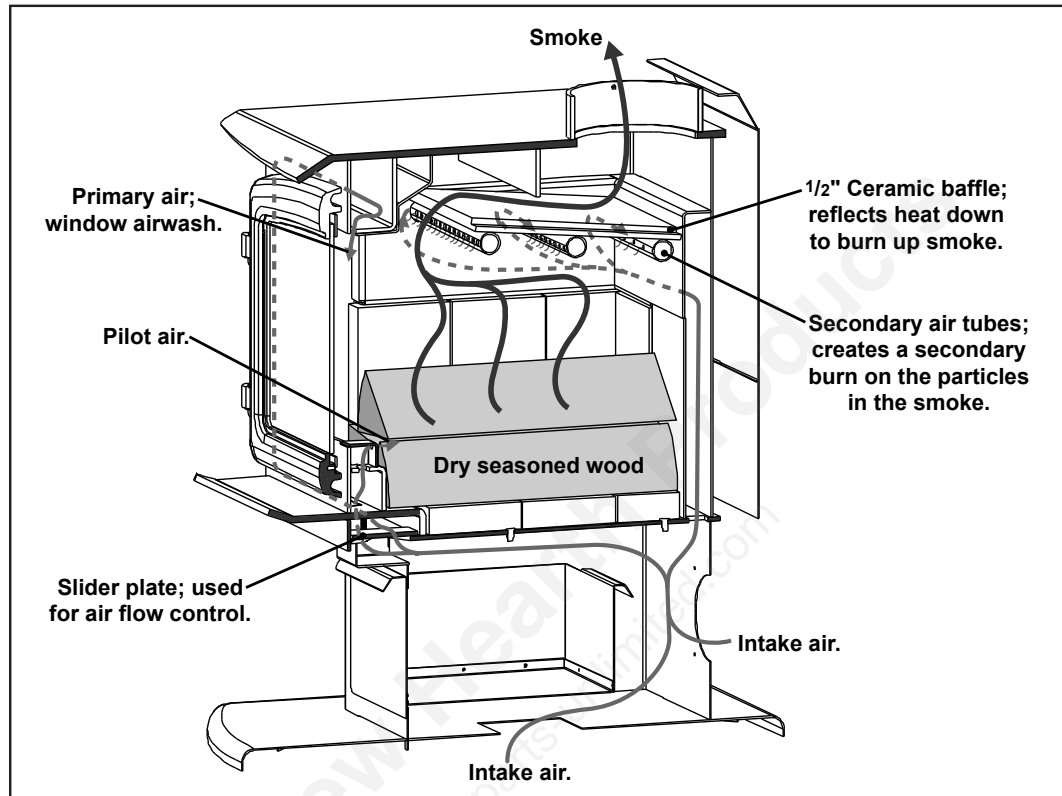

Figure 5: 1200 Air Flow Path.

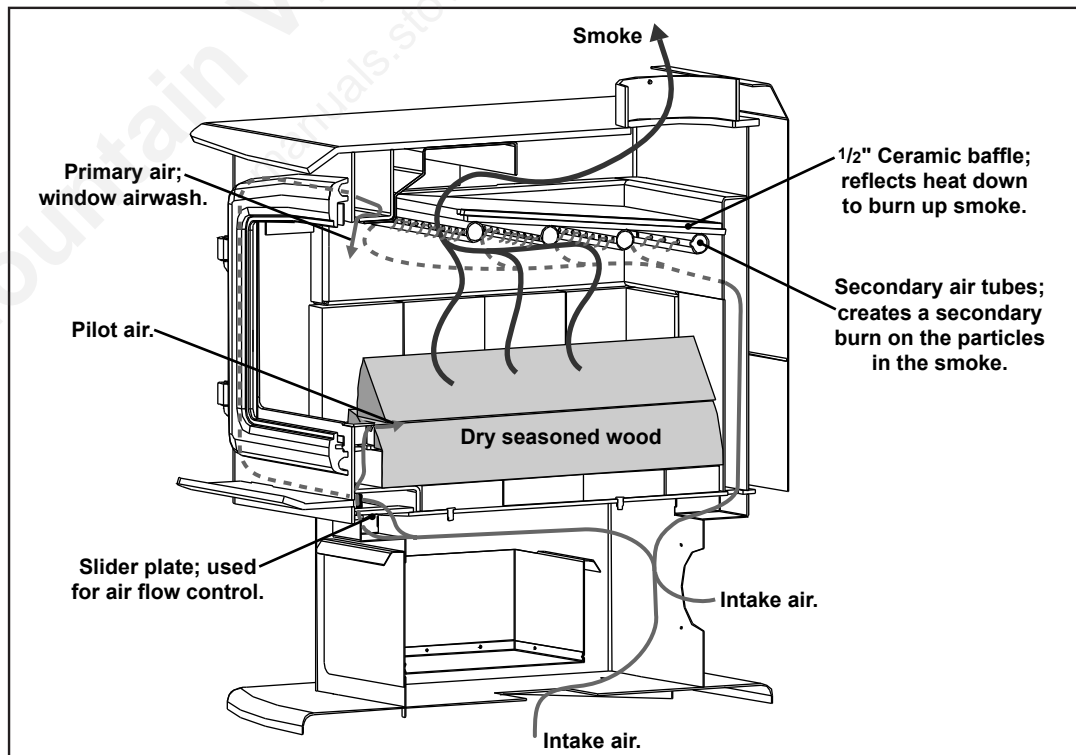

Figure 6: 1700 Air Flow Path.

# SPECIFICATIONS

## 1200 SPECIFICATIONS:

**Table 1: 1200 General Information.**

Model	1200 Freestanding	
	Flat Top	Step Top
Width x Depth	25" x 22 7/16" (635 mm x 570 mm)	
Height with pedestal or legs	28 1/4" (718mm)	31 1/4" (794 mm)
Height of body	18 1/4" (464 mm)	21 1/4" (540 mm)
Fire box size (depth x width x height)	16.1" x 18.25" x 11.15" (409 mm x 464 mm x 283 mm)	
Capacity	1.85 feet <sup>3</sup> (0.0526 meter <sup>3</sup> )	
* Approximate heating area	2200 feet <sup>2</sup> (205 meter <sup>2</sup> )	
**E.P.A. output rating	11,479 to 34,196 BTU/hour (3,361 to 10,013 watt)	
*Duration on low burn	6 -10 hours	
Weight with packaging	335 lb (151.95 Kg)	375 lb (170.10 Kg)
E.P.A. Emissions	3.3 grams/hour (0.116 oz/hour)	
Standard (width x height)	/	
Oversized (width x height)	/	
Rating Label Location	Back of Unit	

# SPECIFICATIONS

## 1700 SPECIFICATIONS:

**Table 2: 1700 General Information.**

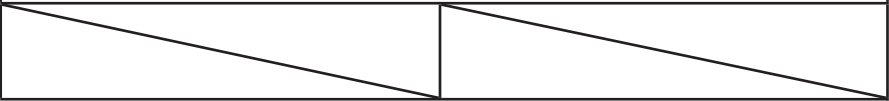
Model	1700 Freestanding	
	Flat Top	Step Top
Width x Depth	25" x 26 <sup>15</sup> / <sub>16</sub> " (635 mm x 684 mm)	
Height with pedestal or legs	28 <sup>1</sup> / <sub>4</sub> " (718mm)	31 <sup>1</sup> / <sub>4</sub> " (794 mm)
Height of body	18 <sup>1</sup> / <sub>4</sub> " (464 mm)	21 <sup>1</sup> / <sub>4</sub> " (540 mm)
Fire box size (depth x width x height)	20.65" x 18.25" x 11.95" (525 mm x 464 mm x 304 mm)	
Capacity	2.5 feet <sup>3</sup> (0.0708 meter <sup>3</sup> )	
* Approximate heating area	3000 feet <sup>2</sup> (280 meter <sup>2</sup> )	
**E.P.A. output rating	9,425 to 31,780 BTU/hour (2,760 to 9,306 watt)	
*Duration on low burn	8 - 12 hours	
Weight with packaging	390 lb (176.90 Kg)	420 lb (190.51 Kg)
E.P.A. Emissions	4.48 grams/hour (0.158 oz/hour)	
Oversized (width x height)		
Rating Label Location	Back of Unit	

# SPECIFICATIONS

## CLEARANCES TO COMBUSTIBLES - 1200 FREESTANDING:

### MAINTAIN THESE MINIMUM CLEARANCES TO UNSHIELDED COMBUSTIBLES\*

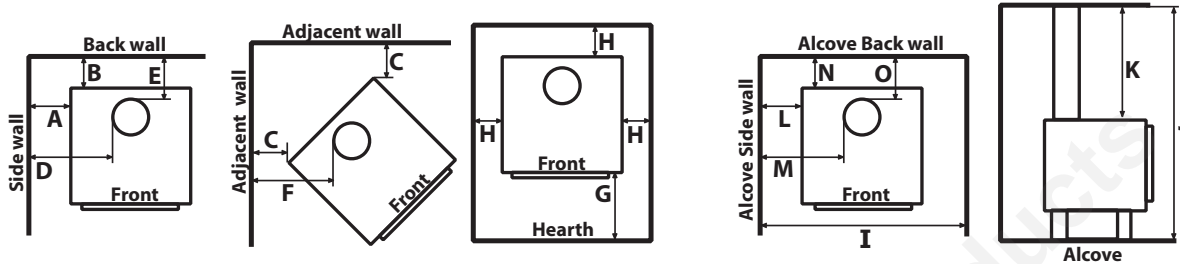

**Table 3: 1200 Freestanding Clearance to Combustibles.**

		Single Wall Pipe	Double Wall Pipe**	Double Wall Pipe with Heat Efficiency Shield 50-1088 (Flat top model only)	Top vent out back wall with min. 24" (610 mm) vertical rise; double wall
A	From side wall to side of unit	13" (330 mm)	13" (330 mm)	13" (330 mm)	14" (356 mm)
B	From rear wall to back of unit	11" (279 mm)	10" (254 mm)	8" (203 mm)	12" (305 mm)
C	From adjacent wall to corner of unit	9" (229 mm)	8" (203 mm)	6½" (165 mm)	
D	From side wall to collar	22" (559 mm)	22" (559 mm)	22" (559 mm)	23" (584 mm)
E	From rear wall to collar	14" (356 mm)	13" (330 mm)	11" (279 mm)	15" (381 mm)
F	From adjacent wall to collar	17½" (445 mm)	16½" (419 mm)	15" (368 mm)	
G	† From door opening to edge of hearth pad	USA 16" (406 mm) CND 18" (450 mm)	USA 16" (406 mm) CND 18" (450 mm)	USA 16" (406 mm) CND 18" (450 mm)	USA 16" (406 mm) CND 18" (450 mm)
H	† From side/back of unit to edge of hearth pad	USA 6" (152 mm) CND 8" (200 mm)	USA 6" (152 mm) CND 8" (200 mm)	USA 6" (152 mm) CND 8" (200 mm)	USA 6" (152 mm) CND 8" (200 mm)
Alcove (48" [1220 mm] Deep)					
I	Total Width		55" (1397 mm)		
J	Total Height		78" (1981 mm)		
K	Top of stove to ceiling		49" (1245 mm)		
L	Side wall to stove		15" (381 mm)		
M	Side wall to pipe		24" (610 mm)		
N	Back wall to unit		12" (305 mm)		
O	Back wall to pipe		15" (381 mm)		

**CAUTION:** An uninsulated smoke pipe must not pass through an attic, roof space, closet or similar concealed space, or through a floor, ceiling, wall, or partition, or any combustible construction.

† **FLOOR PROTECTION:** If a stove is installed on a combustible floor, it must have a pedestal or leg kit with ash pan attached and be on a NON-COMBUSTIBLE hearth pad

\* ALL CLEARANCES CAN BE REDUCED WITH SHIELDING ACCEPTABLE TO THE LOCAL AUTHORITY.

\*\*DOUBLE WALL:

IN CANADA: Any ULC-S629 listed chimney system with the accompanying listed double wall vent connector.

IN U.S.A.: Any UL 103 HT listed chimney system with the accompanying listed double wall vent connector.

# SPECIFICATIONS

## CLEARANCES TO COMBUSTIBLES - 1700 FREESTANDING:

### MAINTAIN THESE MINIMUM CLEARANCES TO UNSHIELDED COMBUSTIBLES\*

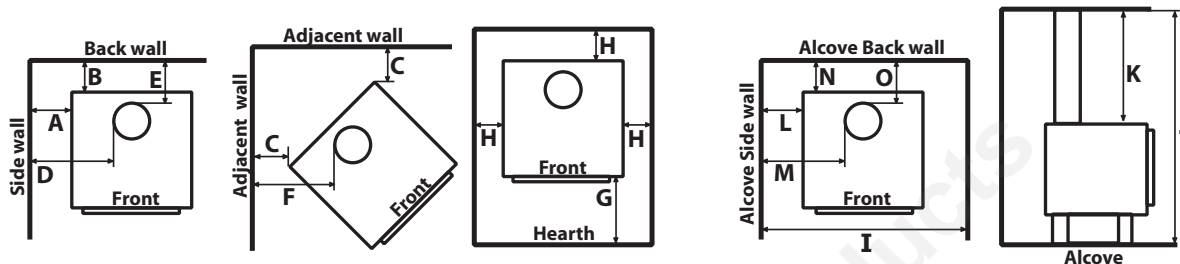

**Table 4: 1700 Freestanding Clearance to Combustibles.**

		Single Wall Pipe	Double Wall Pipe**	Double Wall Pipe with Heat Efficiency Shield 50-1088 (Flat top model only)	Top vent out back wall with min. 24" (610 mm) vertical rise; double wall
A	From side wall to side of unit	20" (508 mm)	13" (330 mm)	13" (330 mm)	11" (279 mm)
B	From rear wall to back of unit	12" (305 mm)	10" (254 mm)	7" (178 mm)	13" (330 mm)
C	From adjacent wall to corner of unit	10" (254 mm)	8½" (216 mm)	6" (152 mm)	
D	From side wall to collar	29" (737 mm)	22" (559 mm)	22" (559 mm)	20" (508 mm)
E	From rear wall to collar	15" (381 mm)	13" (330 mm)	10" (254 mm)	16" (406 mm)
F	From adjacent wall to collar	18½" (470 mm)	17" (432 mm)	14½" (368 mm)	
G	† From door opening to edge of hearth pad	USA 16" (406 mm) CND 18" (450 mm)	USA 16" (406 mm) CND 18" (450 mm)	USA 16" (406 mm) CND 18" (450 mm)	USA 16" (406 mm) CND 18" (450 mm)
H	† From side/back of unit to edge of hearth pad	USA 6" (152 mm) CND 8" (200 mm)	USA 6" (152 mm) CND 8" (200 mm)	USA 6" (152 mm) CND 8" (200 mm)	USA 6" (152 mm) CND 8" (200 mm)
Alcove (48" Deep)					
I	Total Width		51" (1295 mm)		
J	Total Height		72" (1829 mm)		
K	Top of stove to ceiling		44" (1118 mm)		
L	Side wall to stove		13" (330 mm)		
M	Side wall to pipe		22" (559 mm)		
N	Back wall to unit		8" (203 mm)		
O	Back wall to pipe		11" (279 mm)		

**CAUTION:** An uninsulated smoke pipe must not pass through an attic, roof space, closet or similar concealed space, or through a floor, ceiling, wall, or partition, or any combustible construction.

† **FLOOR PROTECTION:** If a stove is installed on a combustible floor, it must have a pedestal or leg kit with ash pan attached and be on a NON-COMBUSTIBLE hearth pad

\* ALL CLEARANCES CAN BE REDUCED WITH SHIELDING ACCEPTABLE TO THE LOCAL AUTHORITY.

\*\*DOUBLE WALL:

IN CANADA: Any ULC-S629 listed chimney system with the accompanying listed double wall vent connector.

IN U.S.A.: Any UL 103 HT listed chimney system with the accompanying listed double wall vent connector.

# SPECIFICATIONS

## DIMENSIONS - 1200 FREESTANDING:

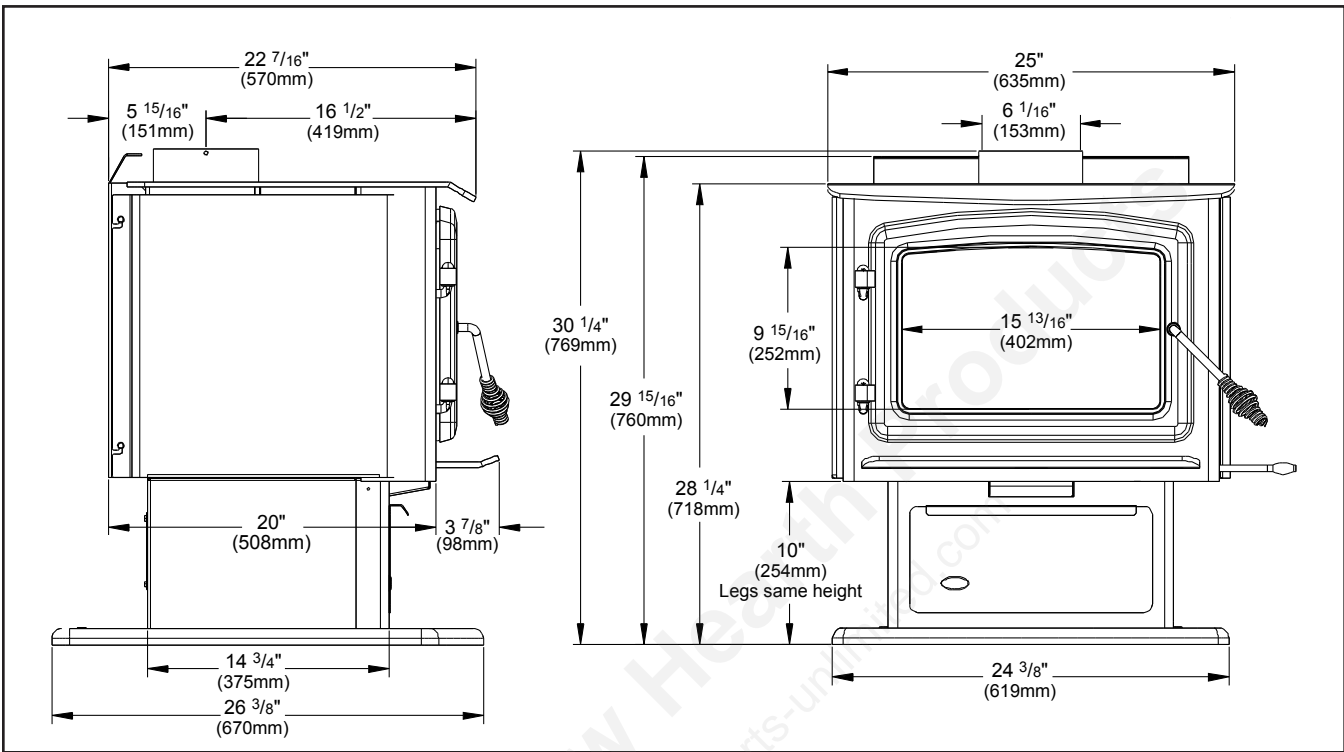

Figure 7: 1200 Freestanding Flat Top Dimensions.

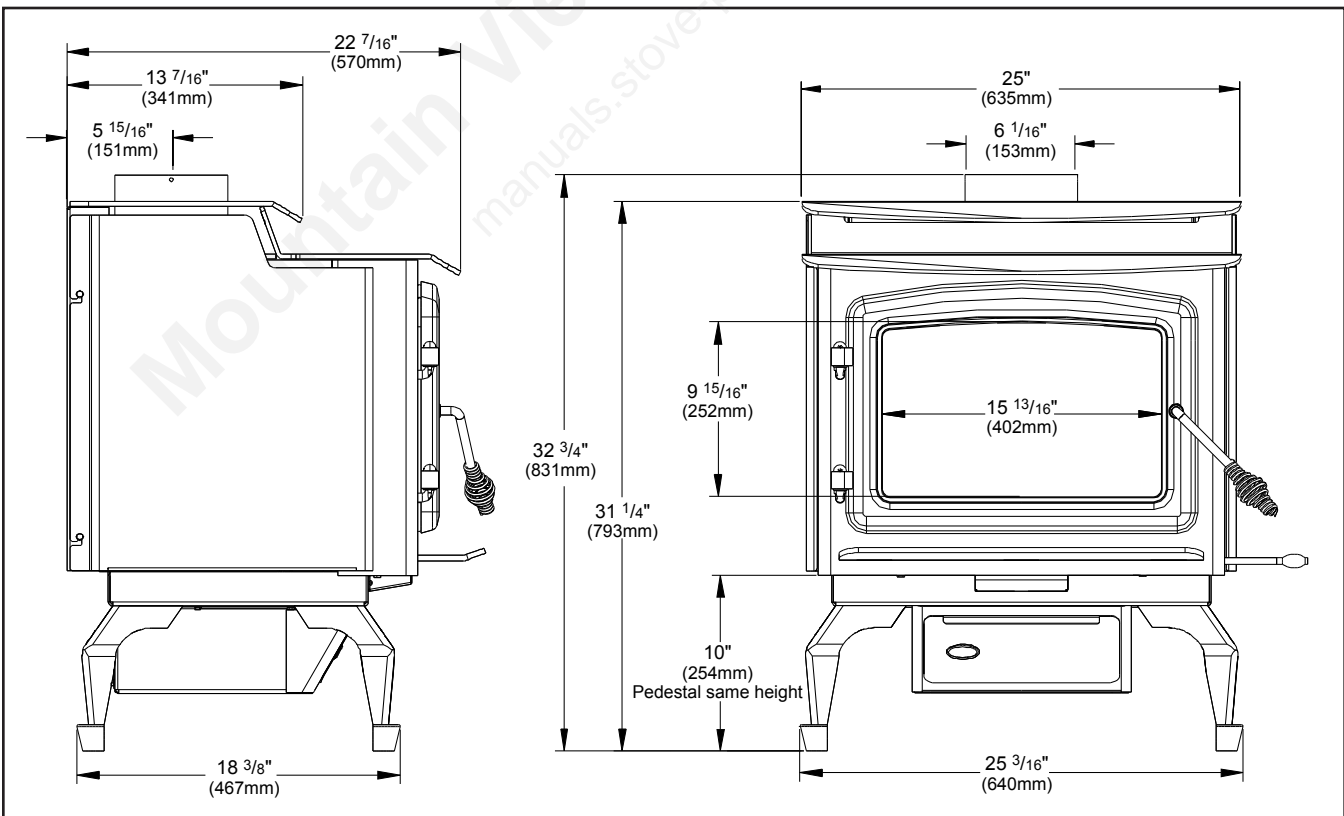

Figure 8: 1200 Freestanding Step Top Dimensions.

# SPECIFICATIONS

## DIMENSIONS - 1700 FREESTANDING:

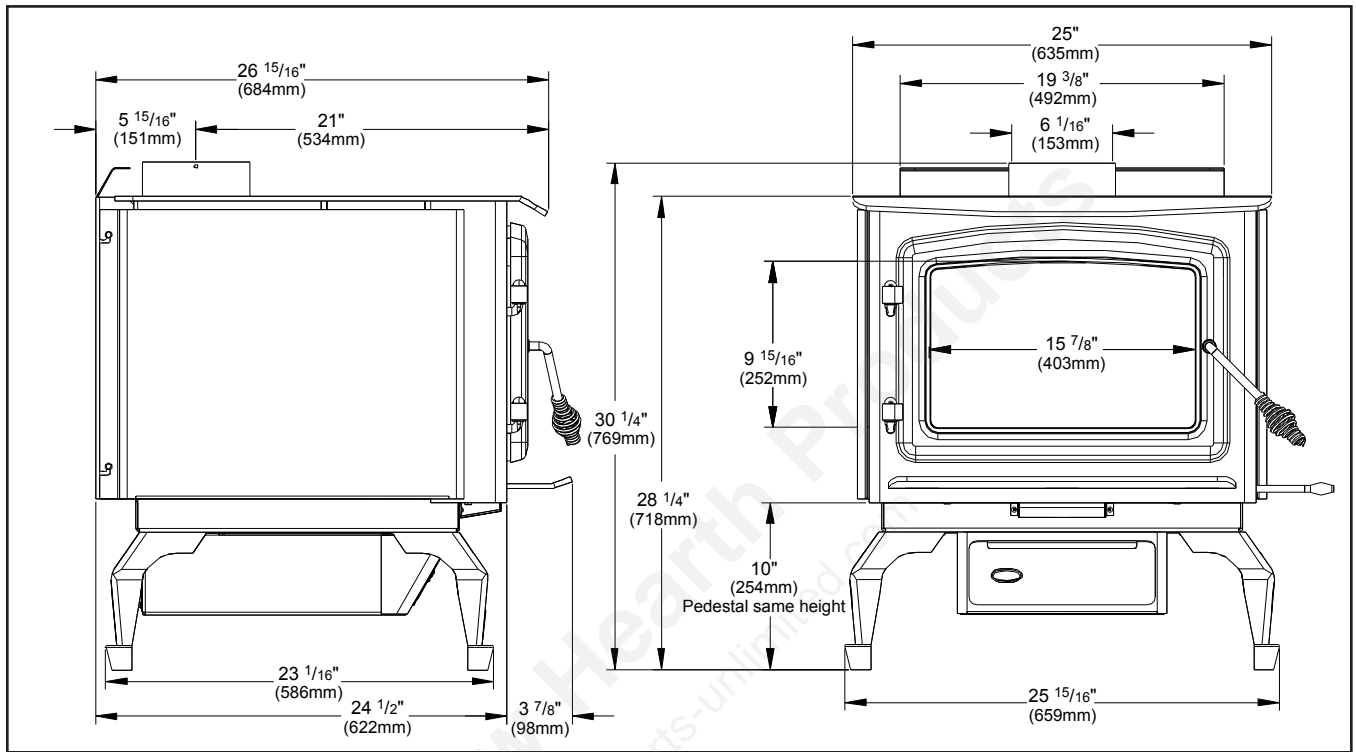

Figure 9: 1700 Freestanding Flat Top Dimensions.

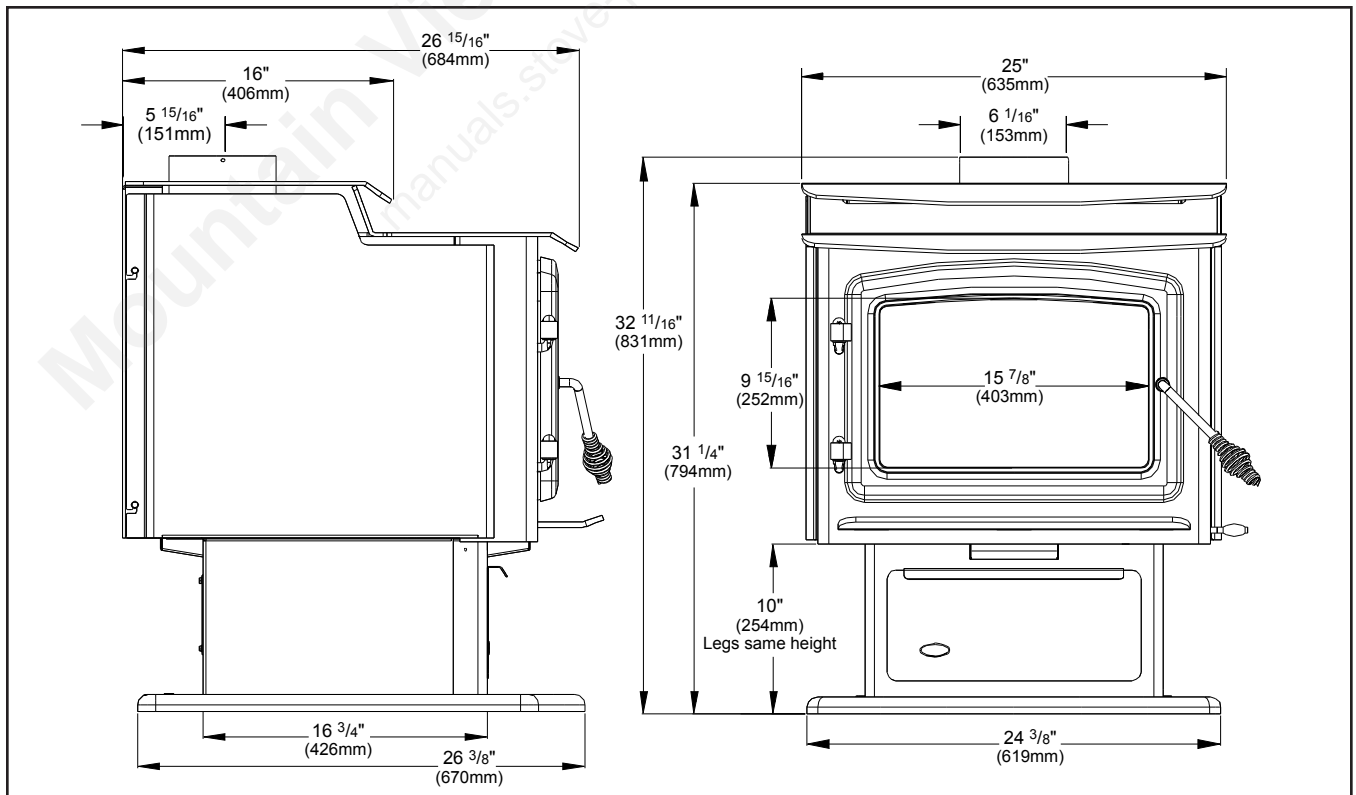

Figure 10: 1700 Freestanding Step Top Dimensions.

# SPECIFICATIONS

## FREESTANDING SIDE DIMENSIONS FOR FAN KIT:

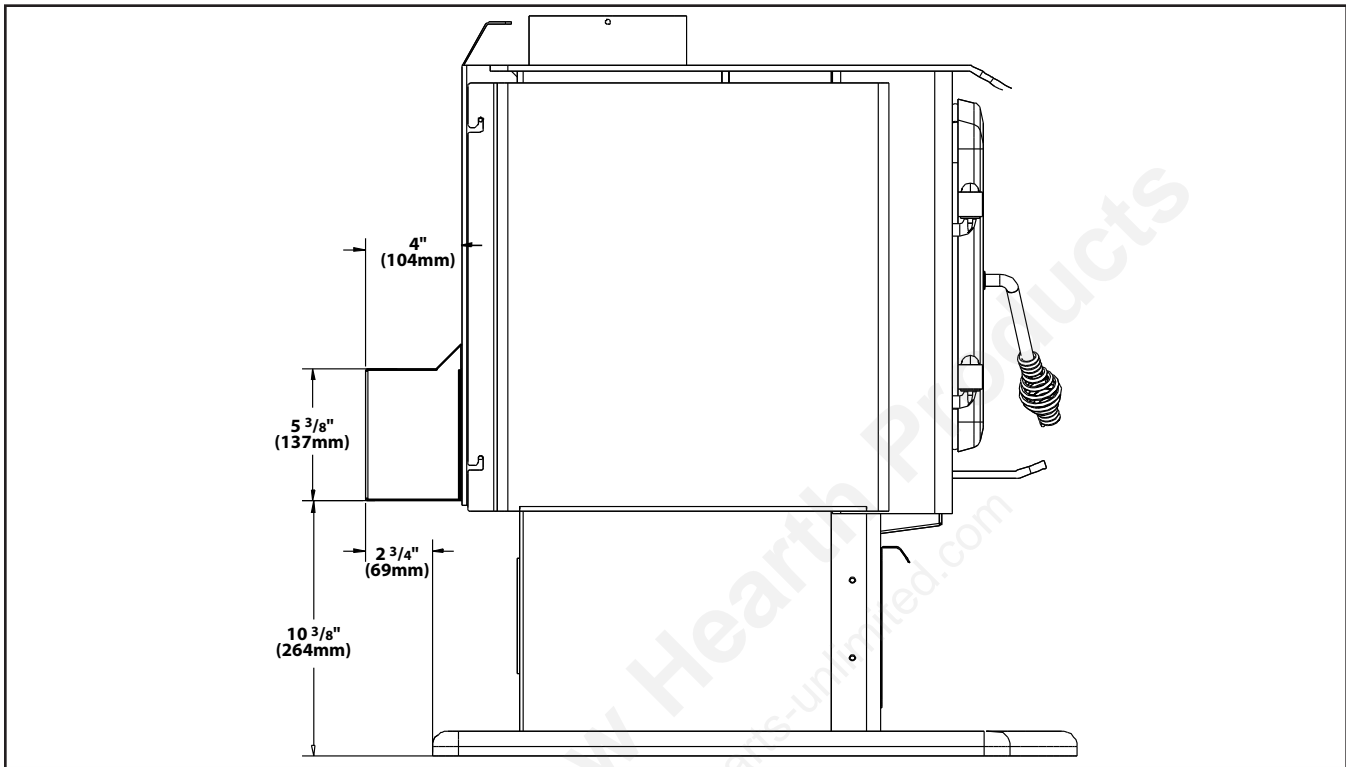

Figure 11: 1200 Freestanding with Fan Kit Dimensions.

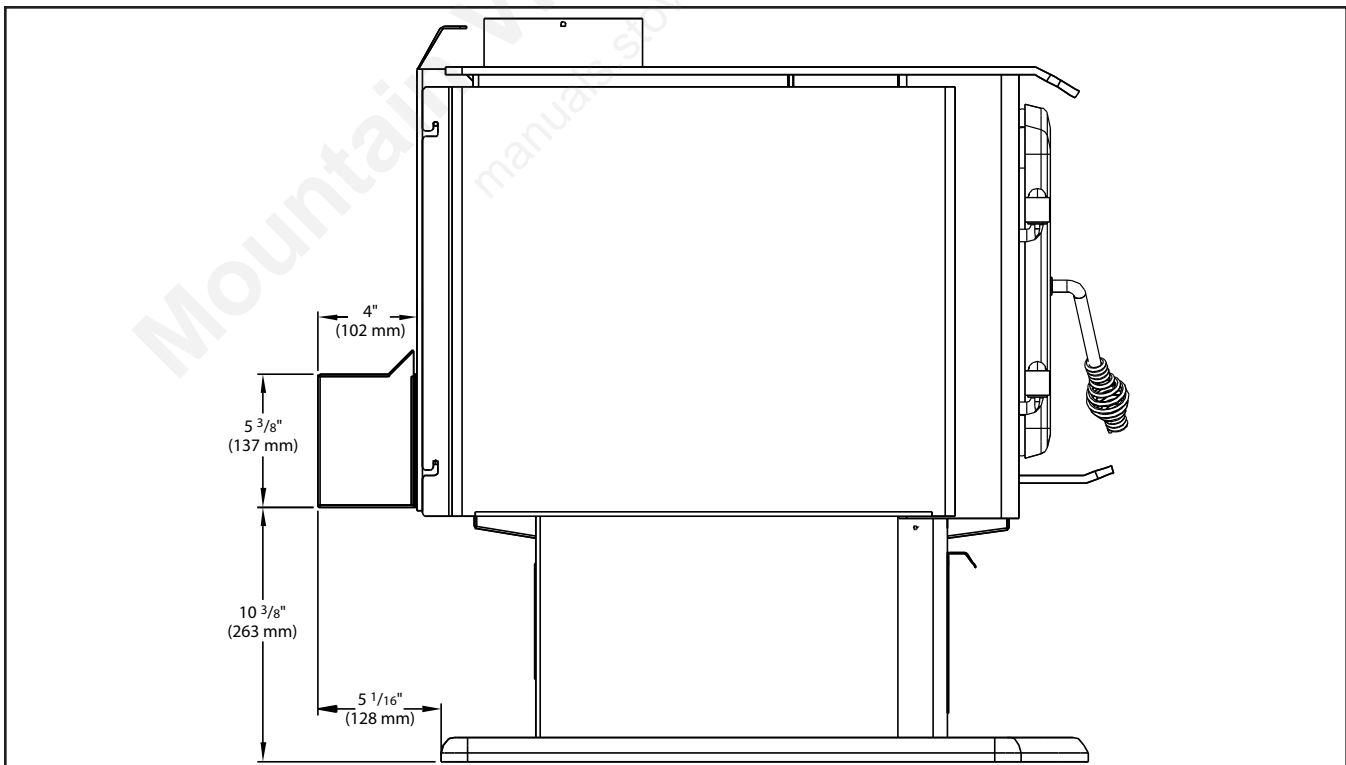

Figure 12: 1700 Freestanding with Fan Kit Dimensions.

# INSTALLATION

Please read and understand these instructions before installing pedestal or ash pan and leg option. Failure to follow these instructions carefully could cause personal injury or property damage. All screws are pre-installed on the base of the unit.

## REMOVAL FROM PALLET:

- Remove the bricks from the unit before starting.
- Remove the two (2) lag bolts (shown in Figure 1) that secure the unit to the pallet from inside the firebox.

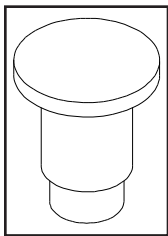

**Figure 13:**  
Rivet.

**Note:** After the pedestal or legs and ash pan have been installed but before the bricks are installed, rivets (Figure 13) must be placed in the two (2) holes (shown in Figure 14) in the firebox that lag bolts came out of. This is done to make unit burn more efficiently.

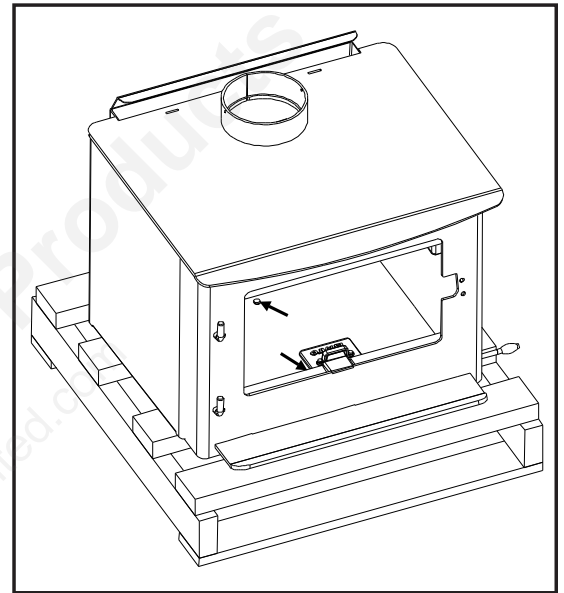
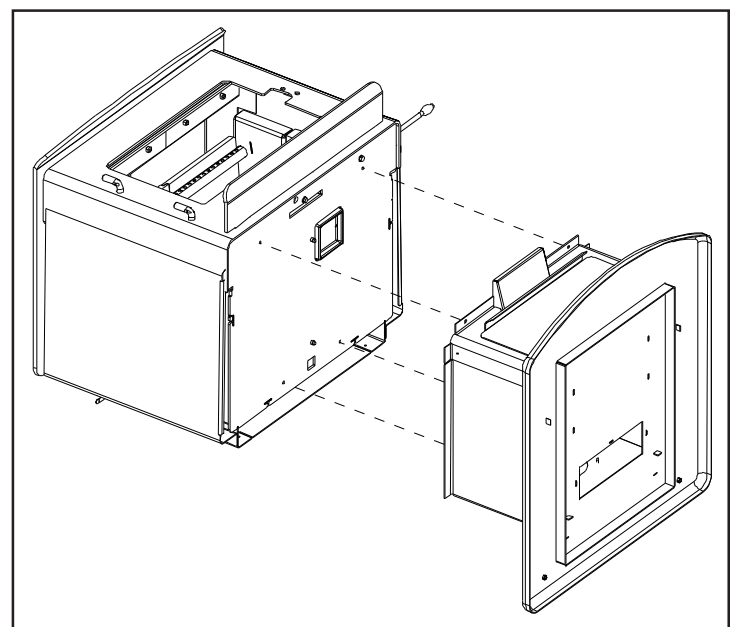

**Figure 14: Bolts to remove.**

## PEDESTAL INSTALLATION - FREESTANDING:

- Place the unit on the pallet on its back.
- Remove the front two (2) provided Pedestal bolts, slide the pedestal assembly over the rear bolts located on the base of the unit, and re-install the front bolts through the Pedestal holes.
- Tighten all four (4) bolts ensuring the pedestal is properly aligned to the edges of the unit.
- Stand the unit on the pedestal and set the unit in the location ready for installation.
- If fresh air supply is being supplied from the bottom of the unit please install the cover plate supplied to the rear of the pedestal covering the 4" (10 cm) hole.

**Note:** In seismically active areas, it is recommended that your unit is secured to the floor by using the bolt down holes at the rear of the pedestal.

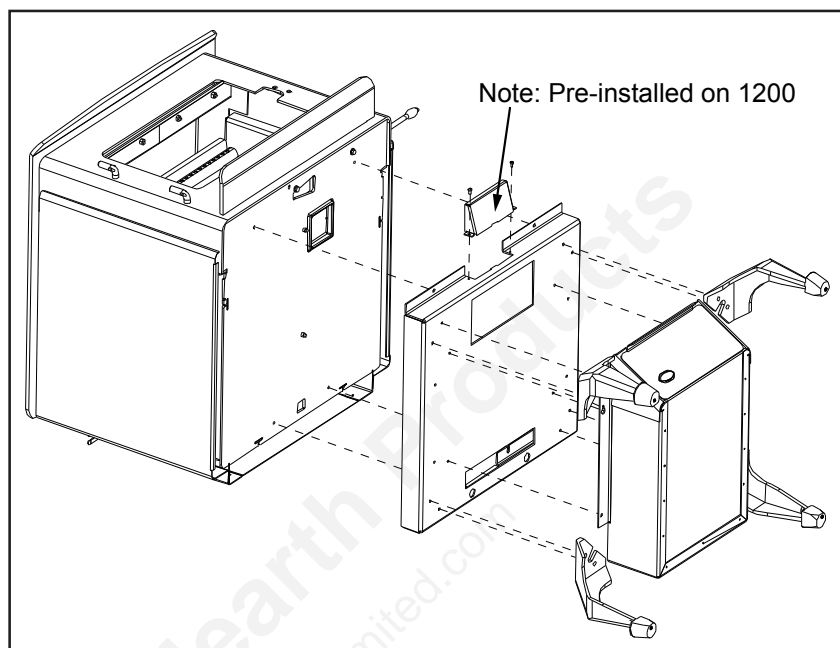

**Figure 15: Installing Pedestal.**

# INSTALLATION

## LEGS AND ASH PAN INSTALLATION - FREESTANDING:

- Place the unit on the pallet on its back.
- Attach the Leg Adaptor Plate to the bottom of the unit using the supplied screws
- 1700 Only: Attach the air channel box to the front of the pedestal spacer using two (2) T-20 screws
- Remove the rear two provided Leg Box bolts, slide the Leg Box assembly over the front bolts located on the base of the unit, and reinstall the rear bolts thru the Leg Box holes and tighten all four (4) bolts.
- Carefully remove the cast iron legs from the packaging and secure each leg with two (2) bolts provided.
- Secure all four (4) legs, push the leg towards the center of the stove and align the legs with the outer edges of the firebox.
- Stand the unit on the legs and set the unit in the location ready for installation.

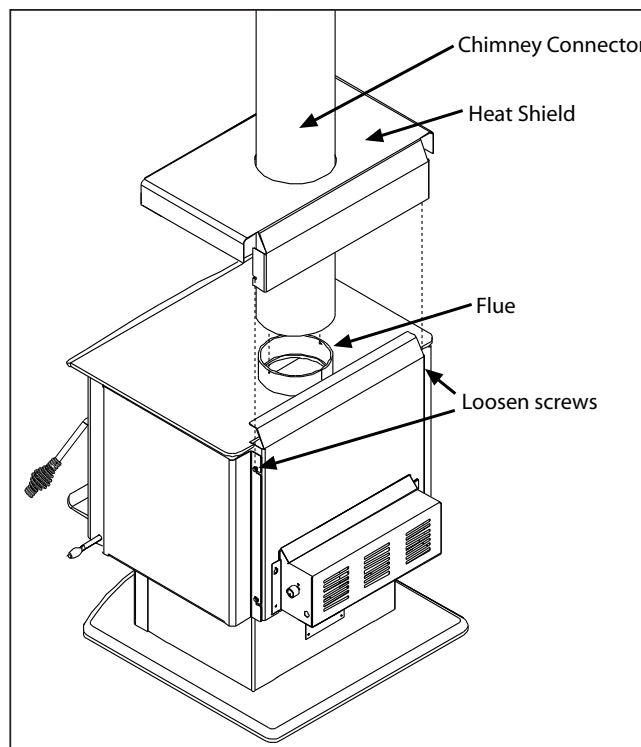

**Figure 16: Installing Legs and Ash Pan Assembly.**

## INSTALLATION OF HEAT-EFFICIENCY SHIELD - FREESTANDING FLAT TOP:

The heat-efficiency shield is installed to lower the clearances to combustibles on the flat top freestanding model.

1. The unit must be in position for the installation and with the venting ready to be assembled.
2. Loosen the two (2) top screws on the back of the unit using a  $\frac{5}{16}$ " socket.
3. Place the heat-efficiency shield on top of unit.
4. Slide chimney connector through the heat-efficiency shield and over the flue.
5. Lift the heat-efficiency shield and screw the chimney connector to the flue.
6. Slide the heat-efficiency shield down and hook the slot at the back of the shield, around the loosened screws at the back of the unit.
7. Tighten the two (2) screws at the back.



**Figure 17: Installing Heat Shield.**

# INSTALLATION

## HEARTH PROTECTION EXAMPLES:

**Table 5: Examples of Hearth Pad Sizing Using Clearances From Tables 3 & 4 (refer to Figures 16 & 17).**

	Canada		USA	
	1200	1700	1200	1700
(A) Minimum Width	40½" (1028mm)		36½" (926mm)	
(B) Minimum Depth	46" (1168mm)	50½" (1283mm)	42" (1067mm)	46½" (1181mm)
OPTIONAL - Corner removal				
(C) Maximum Front Corners - Adjacent	8¾" (314mm)		6¾" (171mm)	
(D) Maximum Back Corners - Adjacent	6¼" (160mm)		5⅞" (130mm)	
(E) Maximum Front Corners - Diagonal	12¾" (314mm)		9½" (242mm)	
(F) Maximum Back Corners - Diagonal	8⅞" (227mm)		7¼" (185mm)	
(G) Minimum Width remaining without corners - Front	23" (583mm)		23" (583mm)	
(H) Minimum Width remaining without corners - Back	27⅞" (707mm)		26⅞" (665mm)	

**Table 6: Examples of Parallel Installation Using Clearances From Tables 3 & 4 (refer to Figure 16).**

	Model	Country	(I) Far Edge of Hearth Pad to Side Wall - Minimum	(J) Front of Hearth Pad to Back Wall - Minimum
Single Wall Pipe	1200	Canada	45½" (1156mm)	49¼" (1252mm)
		USA	43½" (1104mm)	47¼" (1201mm)
	1700	Canada	52½" (1333mm)	54¾" (1391mm)
		USA	50½" (1283mm)	52¾" (1340mm)
Double Wall Pipe	1200	Canada	45½" (1156mm)	48¼" (1226mm)
		USA	43½" (1104mm)	46¼" (1175mm)
	1700	Canada	45½" (1156mm)	52¾" (1340mm)
		USA	43½" (1104mm)	50¾" (1290mm)
Double Wall Pipe with Heat Efficiency Shield 50-1088 (Flat top model only)	1200	Canada	45½" (1156mm)	46¼" (1175mm)
		USA	43½" (1104mm)	44¼" (1125mm)
	1700	Canada	45½" (1156mm)	50¾" (1290mm)
		USA	43½" (1104mm)	47¾" (1213mm)
Top vent out back wall with min. 24" (610mm) vertical rise; double wall	1200	Canada	46½" (1181mm)	50¼" (1277mm)
		USA	44½" (1129mm)	48¼" (1226mm)
	1700	Canada	43½" (1104mm)	55¾" (1417mm)
		USA	41½" (1053mm)	53¾" (13466mm)

# INSTALLATION

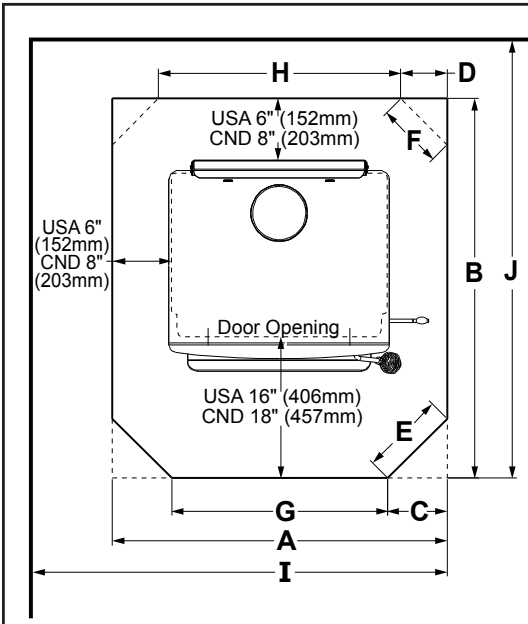

**Figure 18: General Parallel Installation (refer to Tables 5 & 6).**

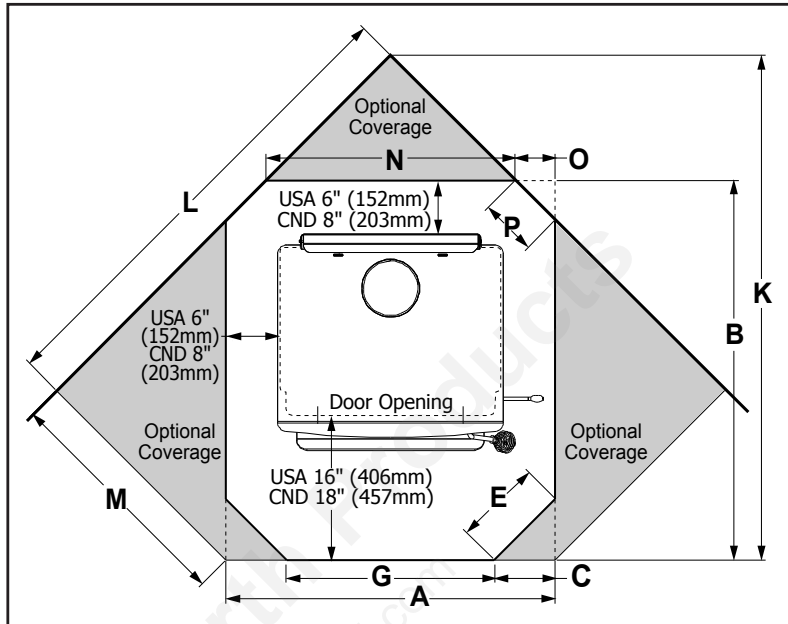

**Figure 19: General Corner Installation (refer to Tables 5 & 7).**

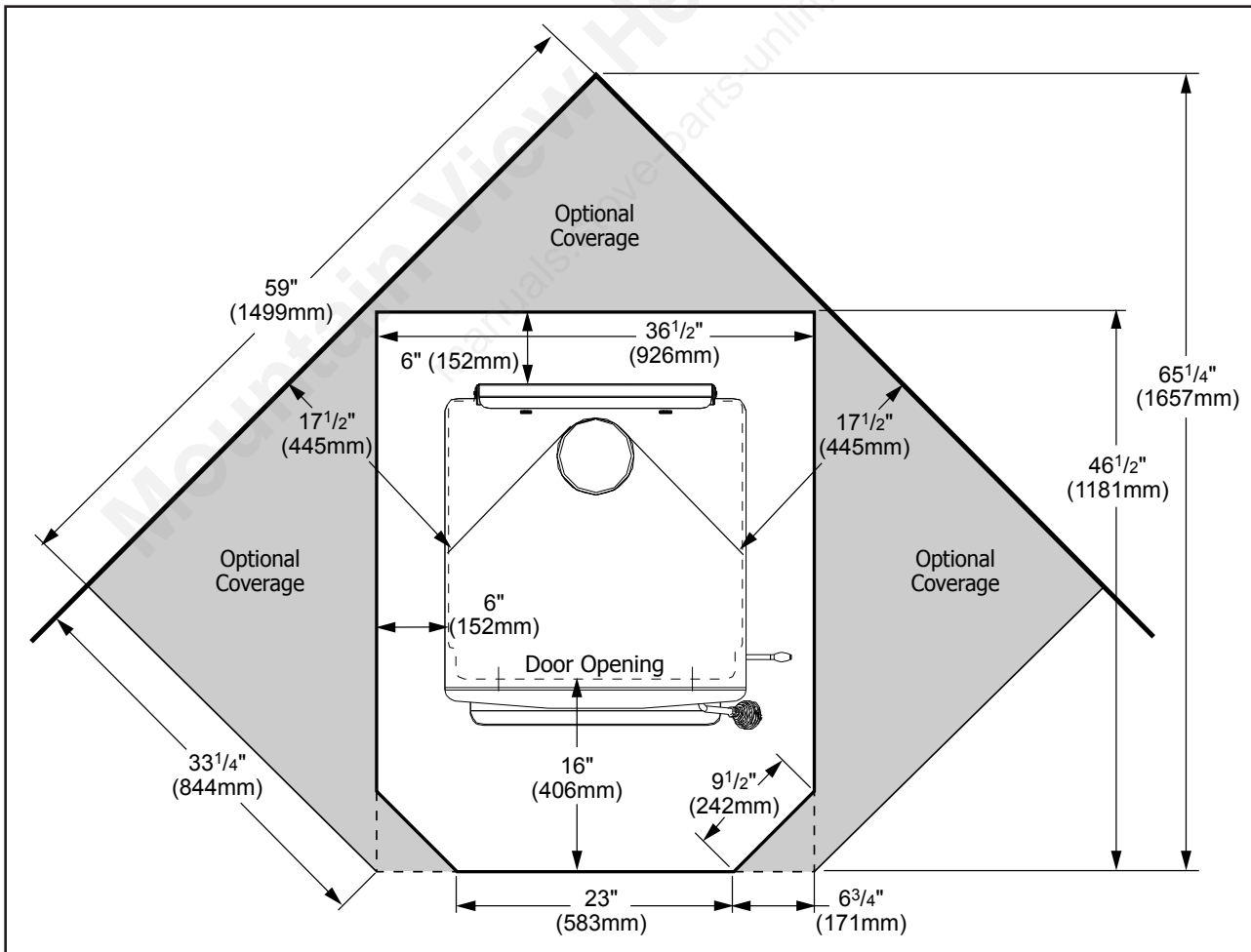

**Figure 20: Corner Installation for 1700 in USA using Single Wall Pipe (refer to Tables 4, 5, & 7).**

# INSTALLATION

**Table 7: Examples of Corner Installation Using Clearances From Tables 9 & 10 (refer to Figures 23 & 24).**

		(K) Front of Hearth Pad to Corner	(L) Adjacent Wall	(M) Edge of Hearth Pad to Adjacent Wall	(N) Width at back of Hearth Pad	(O) Back Corner Removed - Adjacent	(P) Back Corner Removed - Diagonal
Single Wall Pipe	1200	Canada 61 <sup>3</sup> / <sub>8</sub> " (1558mm)	57 <sup>5</sup> / <sub>8</sub> " (1465mm)	29 <sup>1</sup> / <sub>8</sub> " (738mm)	30 <sup>5</sup> / <sub>8</sub> " (779mm)	47 <sup>8</sup> / <sub>8</sub> " (124mm)	7 <sup>1</sup> / <sub>8</sub> " (182mm)
		USA 59 <sup>3</sup> / <sub>8</sub> " (1507mm)	54 <sup>7</sup> / <sub>8</sub> " (1393mm)	29 <sup>1</sup> / <sub>8</sub> " (738mm)	34 <sup>5</sup> / <sub>8</sub> " (881mm)	7 <sup>8</sup> / <sub>8</sub> " (23mm)	1 <sup>1</sup> / <sub>4</sub> " (32mm)
Double Wall Pipe	1700	Canada 67 <sup>1</sup> / <sub>4</sub> " (1708mm)	61 <sup>7</sup> / <sub>8</sub> " (1571mm)	33 <sup>1</sup> / <sub>4</sub> " (844mm)	33 <sup>1</sup> / <sub>2</sub> " (851mm)	3 <sup>1</sup> / <sub>2</sub> " (88mm)	4 <sup>7</sup> / <sub>8</sub> " (125mm)
		USA 65 <sup>1</sup> / <sub>4</sub> " (1657mm)	59" (1499mm)	33 <sup>1</sup> / <sub>4</sub> " (844mm)	36 <sup>1</sup> / <sub>2</sub> " (926mm)	0" (0mm)	0" (0mm)
Double Wall Pipe	1200	Canada 59 <sup>7</sup> / <sub>8</sub> " (1522mm)	56 <sup>5</sup> / <sub>8</sub> " (1439mm)	28 <sup>1</sup> / <sub>8</sub> " (713mm)	27 <sup>7</sup> / <sub>8</sub> " (707mm)	6 <sup>1</sup> / <sub>4</sub> " (160mm)	8 <sup>7</sup> / <sub>8</sub> " (227mm)
		USA 57 <sup>7</sup> / <sub>8</sub> " (1471mm)	53 <sup>7</sup> / <sub>8</sub> " (1368mm)	28 <sup>1</sup> / <sub>8</sub> " (713mm)	31 <sup>7</sup> / <sub>8</sub> " (809mm)	2 <sup>1</sup> / <sub>4</sub> " (59mm)	3 <sup>1</sup> / <sub>4</sub> " (83mm)
Double Wall Pipe with Heat Efficiency Shield 50- 1088 (Flat top model only)	1700	Canada 65 <sup>1</sup> / <sub>8</sub> " (1654mm)	60 <sup>3</sup> / <sub>8</sub> " (1533mm)	31 <sup>3</sup> / <sub>4</sub> " (806mm)	29 <sup>1</sup> / <sub>4</sub> " (743mm)	5 <sup>5</sup> / <sub>8</sub> " (142mm)	7 <sup>7</sup> / <sub>8</sub> " (201mm)
		USA 63 <sup>1</sup> / <sub>8</sub> " (1603mm)	57 <sup>1</sup> / <sub>2</sub> " (1461mm)	31 <sup>3</sup> / <sub>4</sub> " (806mm)	33 <sup>1</sup> / <sub>4</sub> " (845mm)	1 <sup>5</sup> / <sub>8</sub> " (41mm)	2 <sup>1</sup> / <sub>4</sub> " (59mm)
Double Wall Pipe with Heat Efficiency Shield 50- 1088 (Flat top model only)	1200	Canada 59 <sup>7</sup> / <sub>8</sub> " (1522mm)	56 <sup>5</sup> / <sub>8</sub> " (1439mm)	28 <sup>1</sup> / <sub>8</sub> " (713mm)	27 <sup>7</sup> / <sub>8</sub> " (707mm)	6 <sup>1</sup> / <sub>4</sub> " (160mm)	8 <sup>7</sup> / <sub>8</sub> " (227mm)
		USA 55 <sup>3</sup> / <sub>4</sub> " (1417mm)	52 <sup>3</sup> / <sub>8</sub> " (1330mm)	26 <sup>5</sup> / <sub>8</sub> " (675mm)	27 <sup>5</sup> / <sub>8</sub> " (701mm)	4 <sup>3</sup> / <sub>8</sub> " (133mm)	6 <sup>1</sup> / <sub>4</sub> " (160mm)
Double Wall Pipe with Heat Efficiency Shield 50- 1088 (Flat top model only)	1700	Canada 64 <sup>3</sup> / <sub>8</sub> " (1636mm)	59 <sup>7</sup> / <sub>8</sub> " (1520mm)	31 <sup>1</sup> / <sub>4</sub> " (794mm)	27 <sup>7</sup> / <sub>8</sub> " (707mm)	6 <sup>1</sup> / <sub>4</sub> " (160mm)	8 <sup>7</sup> / <sub>8</sub> " (227mm)
		USA 59 <sup>5</sup> / <sub>8</sub> " (1514mm)	55" (1398mm)	29 <sup>1</sup> / <sub>4</sub> " (743mm)	26 <sup>1</sup> / <sub>8</sub> " (665mm)	5 <sup>1</sup> / <sub>8</sub> " (130mm)	7 <sup>1</sup> / <sub>4</sub> " (185mm)

# INSTALLATION

## OUTSIDE AIR KIT:

It is mandatory to use outside air for installations in mobile homes.

A 4" (10.2 cm) fresh air adaptor kit is available. This adaptor can be installed either on the back pedestal or through the floor under the pedestal. The cover plate must be installed on the unit if your stove is located in a mobile home or if using outside air from the bottom.

Place the ¼" mesh screen between the fresh air adaptor and the body of the pedestal (as shown to right).

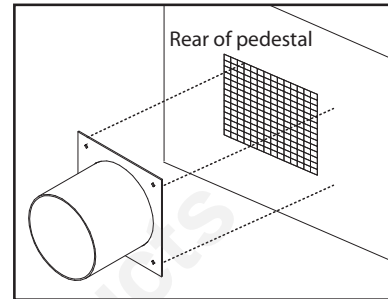

**Figure 21: Fresh Air Adaptor onto the Back of the Pedestal.**

**NOTE:** Fresh air connection to the unit must be a non-combustible pipe, example: 4" (10.2 cm) single wall aluminum flex pipe.

**NOTE:** Remove the cover plate on the rear of the pedestal if room air is to be used for combustion air.

## RECOMMENDED HEIGHTS AND DIAMETERS FOR FLUE PIPE:

The minimum flue pipe height at sea level is 12 feet (3.7 m) straight up from top of the unit. For every 1000 feet (305 m) above sea level, 4% could be added to the overall height. Use Tables 8, 9, and 10 to calculate the required vertical rise required.

**Table 8: Recommended Height for Flue Pipe.**

Elevation above sea level feet	Minimum recommended flue pipe height for # of elbows (Note: No more than 2 offsets (4 elbows) can be used. 2x45°=1x90°)						
	0	2 x 15°	4 x 15°	2 x 30°	4 x 30°	2 x 45°	4 x 45°
0-1000	12.0	12.7	13.3	13.3	14.7	14.0	16.0
1000-2000	12.5	13.2	13.8	13.8	15.3	14.6	16.6
2000-3000	13.0	13.7	14.4	14.4	15.9	15.1	17.3
3000-4000	13.4	14.2	14.9	14.9	16.5	15.7	17.9
4000-5000	13.9	14.7	15.4	15.4	17.1	16.2	18.6
5000-6000	14.4	15.2	16.0	16.0	17.6	16.8	19.2
6000-7000	14.9	15.7	16.5	16.5	18.2	17.4	19.8
7000-8000	15.4	16.3	17.0	17.0	18.8	17.9	20.5
8000-9000	15.8	16.8	17.6	17.6	19.4	18.5	21.1
9000-10000	16.3	17.3	18.1	18.1	20.0	19.0	21.8
meters	0	2 x 15°	4 x 15°	2 x 30°	4 x 30°	2 x 45°	4 x 45°
0-305	3.7	3.9	4.1	4.1	4.5	4.3	4.9
305-610	3.8	4.0	4.2	4.2	4.6	4.4	5.1
610-915	4.0	4.2	4.4	4.4	4.8	4.6	5.3
915-1220	4.1	4.3	4.6	4.6	5.0	4.8	5.5
1220-1525	4.2	4.5	4.7	4.7	5.2	4.9	5.7
1525-1830	4.4	4.6	4.9	4.9	5.4	5.1	5.9
1830-2135	4.5	4.8	5.0	5.0	5.5	5.3	6.0
2135-2440	4.7	4.9	5.2	5.2	5.7	5.5	6.2
2440-2745	4.8	5.1	5.4	5.4	5.9	5.6	6.4
2745-3050	5.0	5.3	5.5	5.5	6.1	5.8	6.6

**Table 9: Distance to add to overall vertical height.**

Part used	Distance to add	
	feet	meters
45° elbow	1.0	0.3
90° elbow	2.0	0.6
"T"	3.0	0.9
1 ft (0.3m) of horizontal run	2.0	0.6

**Table 10: Examples of calculating overall vertical height required.**

Height	
sea level with 2 x 30° elbows	13.3 ft (4.1 m)
one "T"	3.0 ft (0.9 m)
1½ ft (0.6 m) horizontal run	3.0 ft (0.9 m)
<b>Total 1</b>	<b>19.3 ft (5.9 m)</b>
4000-5000 ft (1220-1525 m) above sea level	13.9 ft (4.2 m)
one "T"	3.0 ft (0.9 m)
2 ft (0.6 m) horizontal run	4.0 ft (1.2 m)
<b>Total 2</b>	<b>20.9 ft (6.3 m)</b>

We recommend the use of a 6" (150mm) diameter flue pipe. However, the CSA-B365, NFPA 211 Chapter 12.4.4-1, and the WETT Training Manual state that the flue pipe may be reduced in cross-sectional area provided that the installer ensures sufficient draft is available at the appliance.

# INSTALLATION

## CHIMNEY INSTALLATION THROUGH WALL:

Here are four (4) methods of combustible wall chimney connector pass-throughs. Information was provided from NFPA 211.

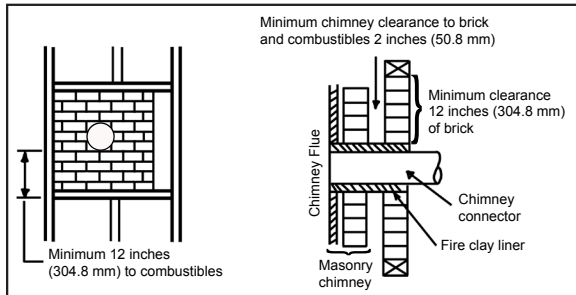

**Figure 22: Chimney Through Wall - Method A.**

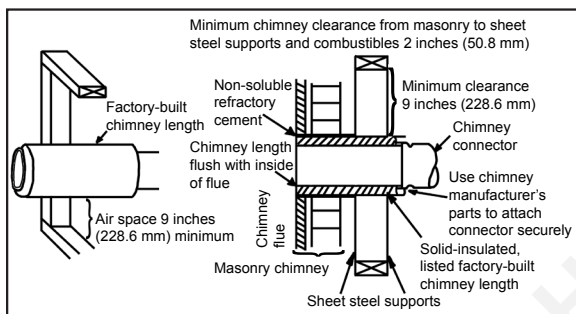

**Figure 23: Chimney Through Wall - Method B.**

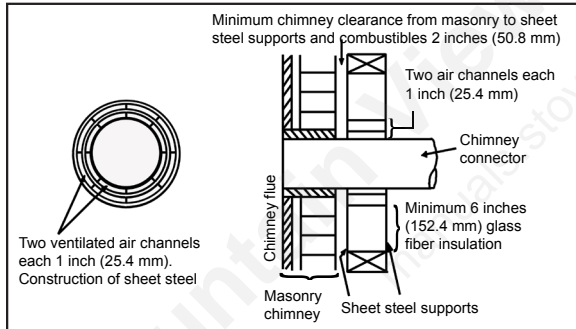

**Figure 24: Chimney Through Wall - Method C.**

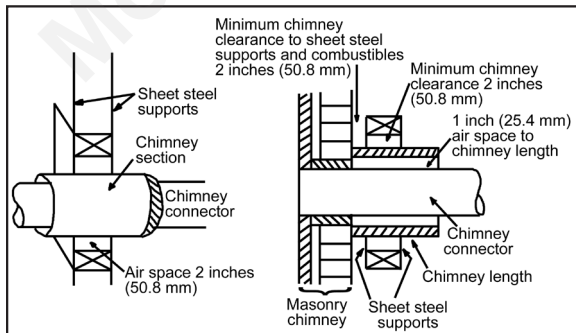

**Figure 25: Chimney Through Wall - Method D.**

**Method A. 12" (304.8 mm) Clearance to Combustible Wall Member:** Using a minimum thickness 3.5" (89 mm) brick and a 5/8" (15.9 mm) minimum wall thickness clay liner, construct a wall pass-through. The clay liner must conform to ASTM C315 (Standard Specification for Clay Fire Linings) or its equivalent. Keep a minimum of 12" (305 mm) of brick masonry between the clay liner and wall combustibles. The clay liner shall run from the brick masonry outer surface to the inner surface of the chimney flue liner but not past the inner surface. Firmly grout or cement the clay liner in place to the chimney flue liner.

**Method B. 9" (229 mm) Clearance to Combustible Wall Member:** Using a 6" (152 mm) inside diameter, factory-built Solid-Pak chimney section with insulation of 1" (25.4 mm) or more, build a wall pass-through with a minimum 9" (229 mm) air space between the outer wall of the chimney length and wall combustibles. Use sheet metal supports, fastened securely to wall surfaces on all sides, to maintain the 9" (229 mm) air space. When fastening supports to chimney length, do not penetrate the chimney liner (the inside wall of the Solid-Pak chimney). The inner end of the Solid-Pak chimney section shall be flush with the inside of the masonry chimney flue and sealed with a non-water soluble refractory cement. Use this cement to also seal to the brick masonry penetration.

**Method C. 6" (152.4 mm) Clearance to Combustible Wall Member:** Starting with a minimum 24 gauge (.024" [0.6 mm]) 6" (152.4 mm) metal chimney connector and a minimum 24 gauge ventilated wall thimble which has two air channels of 1" (25.4 mm) each, construct a wall pass-through. There shall be a minimum 6" (152.4 mm) separation area containing fiberglass insulation, from the outer surface of the wall thimble to wall combustibles. Support the wall thimble and cover its opening with a 24 gauge minimum sheet metal support. Maintain the 6" (152.4 mm) space. There should also be a support sized to fit and hold the metal chimney connector. See that the supports are fastened securely to wall surfaces on all sides. Make sure fasteners used to secure the metal chimney connector do not penetrate chimney flue liner.

**Method D. 2" (50.8 mm) Clearance to Combustible Wall Member:** Start with a solid-pak listed factory-built chimney section at least 12" (304 mm) long, with insulation of 1" (25.4 mm) or more, and an inside diameter of 8" (2" [51 mm] larger than the 6" [152.4 mm] chimney connector). Use this as a pass-through for a minimum 24 gauge single-wall steel chimney connector. Keep solid-pak section concentric with and spaced 1" (25.4 mm) off the chimney connector by way of sheet metal support plates at both ends of chimney section. Cover opening, and support chimney section on both sides, with 24 gauge minimum sheet metal supports. See that the supports are fastened securely to wall surfaces on all sides. Make sure fasteners are used to secure chimney flue liner.

### NOTES:

1. Connectors to a masonry chimney, excepting method B, shall extend in one continuous section through the wall pass-through system and the chimney wall, to but not past the inner flue liner face.
2. A chimney connector shall not pass through an attic or roof space, closet or similar concealed space, or a floor, or ceiling.

# INSTALLATION

## INSTALLATION OF A LISTED, FACTORY BUILT CHIMNEY - FREESTANDING:

**This is a generic set of instructions; always follow the chimney manufacturer's instructions explicitly. Also refer to "RECOMMENDED HEIGHTS FOR FLUE PIPE".**

1. Set floor protector and stove in location in accordance with the "CLEARANCES TO COMBUSTIBLES - 1200 FREESTANDING" or "CLEARANCES TO COMBUSTIBLES - 1700 FREESTANDING".

2. Mark the position for the ceiling hole by suspending a plumb bob from the ceiling over the exact center of your stove flue and mark a spot on the ceiling to indicate the center of the chimney.

3. Move this location, if necessary, to avoid floor joists, ceiling rafters, electrical wiring and plumbing while still maintaining required clearances. If floor joists or ceiling rafters must be cut they must be made structurally sound again. Install chimney according to chimney manufacturer's instructions. A chimney connector cannot pass through an attic or roof space, closet or similar concealed space, or a floor, ceiling, wall or partition of combustible construction. In Canada, if passage through a wall or partition of combustible construction is desired, the installation shall conform to CAN/CSA-B365 Installation Code for Solid-Fuel Burning Appliances and Equipment and NFPA 211 Standard for Chimneys, Fireplaces, Vents, and Solid Fuel-Burning Appliances.

4. Mark the hole for the outside air kit.

5. Move the stove out of the way.

6. Cut a pilot hole in the ceiling.

7. Cut a hole for the ceiling penetration components and frame in the sides of the hole in both the ceiling and roof. Check, and follow chimney manufacturer's instructions for all of these steps.

8. Install the support box and chimney through the roof. Install the slip section for the chimney connector.

9. Slip the roof flashing over the chimney and secure to the roof, being careful to keep the pipe centered in the opening. To meet the code, the chimney must extend above the roof penetration at least 3 feet (91.4 cm),

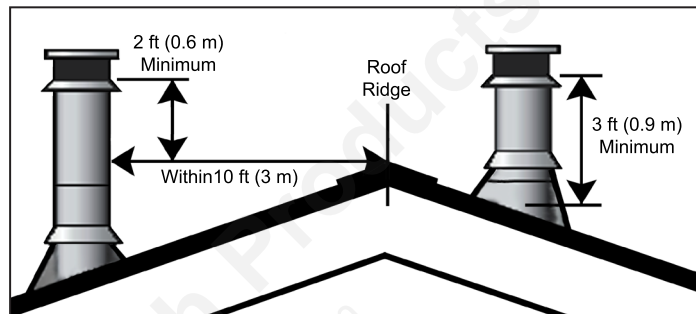

Figure 24: Roof Clearances.

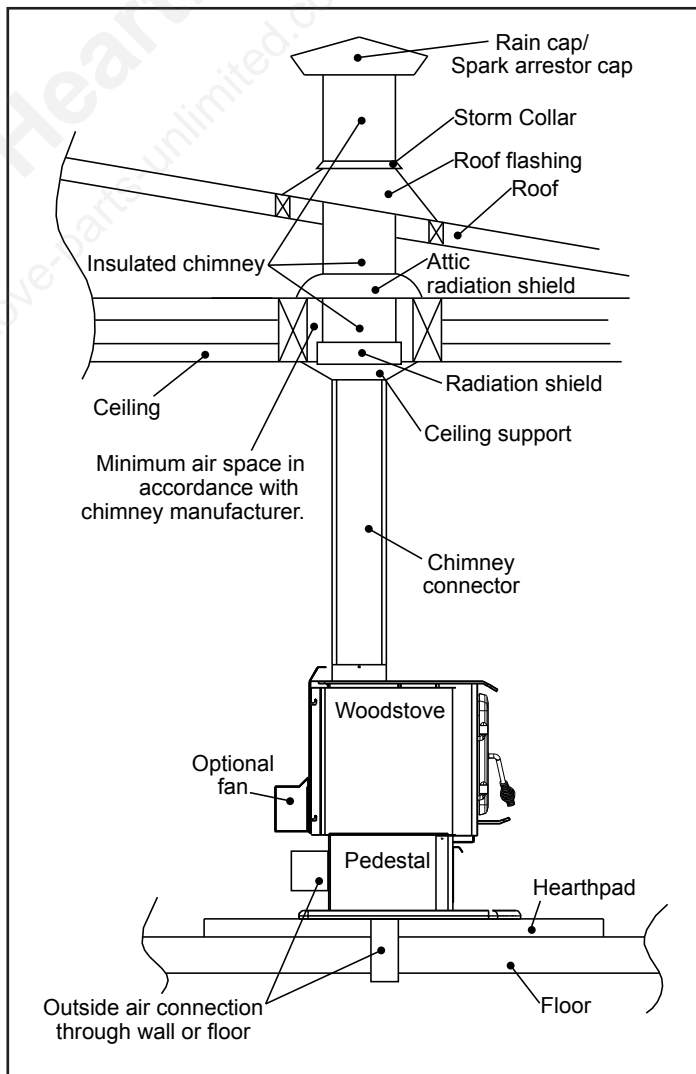

Figure 26: Standard Vertical Installation.

# INSTALLATION

and in any area within 10 feet (304.8 cm) of the roof ridge, the chimney must be 2 feet (60.9 cm) above the ridge. Refer to Figure 30.

**Note:** Increasing the chimney height above the roof may help your unit to draft better. This greater draft can decrease problems such as difficult start-ups, smoke coming out when door is open, and dirty glass. You may initially try the minimum required height and if problems do arise, add additional height later.

- Slide the roof flashing over your chimney and seal the flashing to the roof with a roofing compound. Secure the roof flashing to your roof with nails or screws.
- Place the storm collar over the flashing and seal the joints with silicone caulking.
- Fasten the rain cap / spark arrester cap to the top of your chimney.
- Place the stove back into position.
- Install the chimney connector pipe with the lower (crimped) edge of the pipe inside the flue collar. Any creosote formed will then run back down into the stove. All connections must be tight and secured with three sheet metal screws equally spaced. Double wall pipe is recommended over single wall.
- Also install an outside air flex pipe to the stove.

**IMPORTANT:** When a metal prefabricated chimney is used, the manufacturer's installation instructions must be followed. You must also purchase and install the ceiling support package or wall pass-through and "T" section package, firestops (where needed), insulation shield, roof flashing, chimney cap, etc. Maintain proper clearance to the structure as recommended by the manufacturer. The chimney must be the required height above the roof or other obstructions for safety and proper draft operation.

**Note:** If you are using a horizontal connector (refer to Figure 32), the chimney connector should be as high as possible while still maintaining the 18" (475 mm) minimum distance from the horizontal connector to the ceiling.

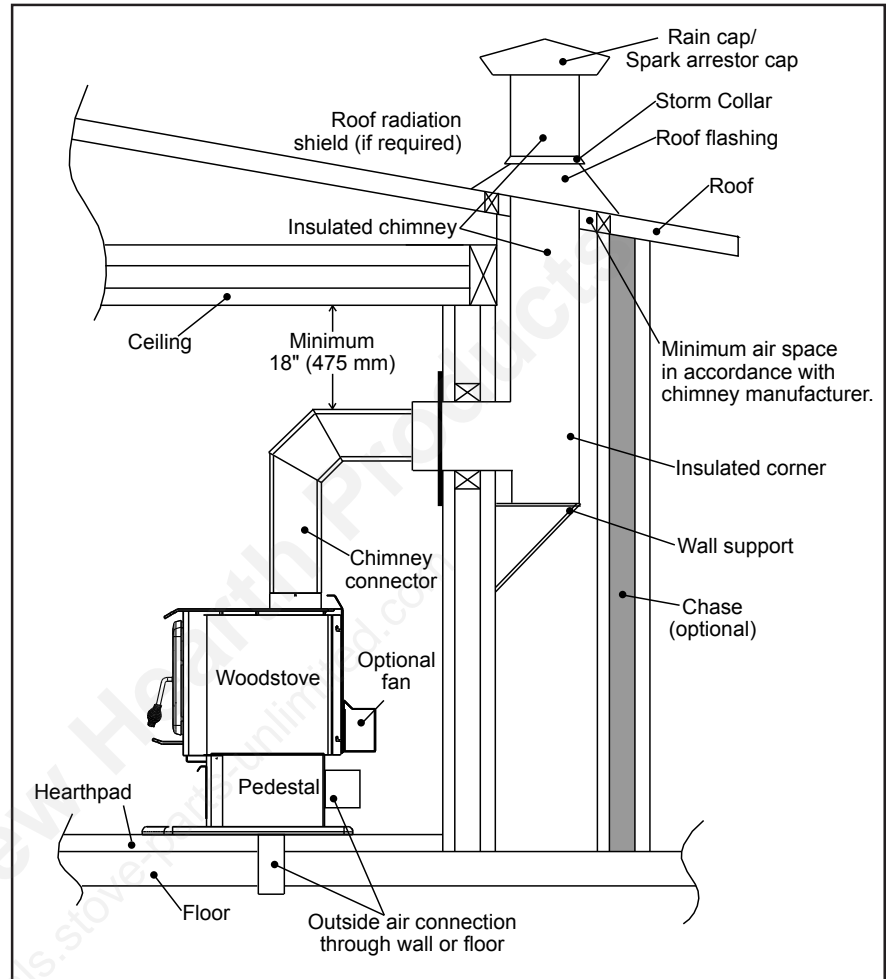

**Figure 27: Standard Horizontal Installation.**

# INSTALLATION

## MASONRY CHIMNEY INSTALLATION - FREESTANDING:

**DO NOT CONNECT THIS UNIT TO OR USE IN CONJUNCTION WITH ANY AIR DISTRIBUTION DUCTWORK UNLESS SPECIFICALLY APPROVED FOR SUCH INSTALLATIONS**

**DO NOT CONNECT THIS UNIT TO A CHIMNEY FLUE SERVING ANOTHER APPLIANCE.**

A non-combustible floor protector is required under all freestanding units; refer to "CLEARANCES TO COMBUSTIBLES - 1200 FREESTANDING" or "CLEARANCES TO COMBUSTIBLES - 1700 FREESTANDING". When venting into a masonry chimney, the floor protector must be installed directly below the chimney vent and 2" (50.8 mm) on either side of the chimney vent.

Vent the stove into a clean, lined, approved masonry chimney in good condition, conforming to local building codes and meeting the minimum standards of the National Fire Protection Association (NFPA). Make sure there are no cracks, loose mortar or other signs of deterioration and blockage. Have the chimney cleaned before the stove is installed and operated, or vent with a listed 6" (150 mm) factory-built chimney suitable for use with solid fuels and conforming to ULC-S629 Standard for 650°C factory-Built Chimneys in CANADA or UL 103 HT Factory-Built Chimneys for Residential Type and Building Heating Appliances in the U.S.A. Connect the stove to this chimney with a short and straight 6" (150 mm), 24 gauge or heavier, single-wall black or blued steel smoke pipe. Connection to all masonry chimneys must be a metal or masonry thimble cemented in place. All smoke pipes must slope upwards, all connections must be tight and secured with three sheet metal screws equally spaced. The smoke pipe length should not exceed 40% of the chimney height above the stove.

When connecting the stove through a combustible wall to a masonry chimney, additional steps are required. Consult the chimney connector manufacturer and refer to Figure 28.

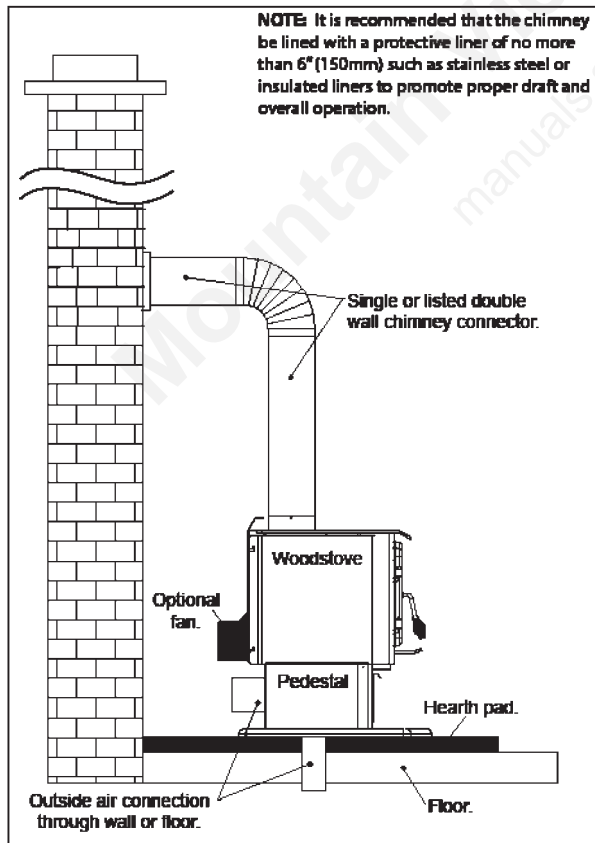

Figure 28: Installation into a masonry chimney.

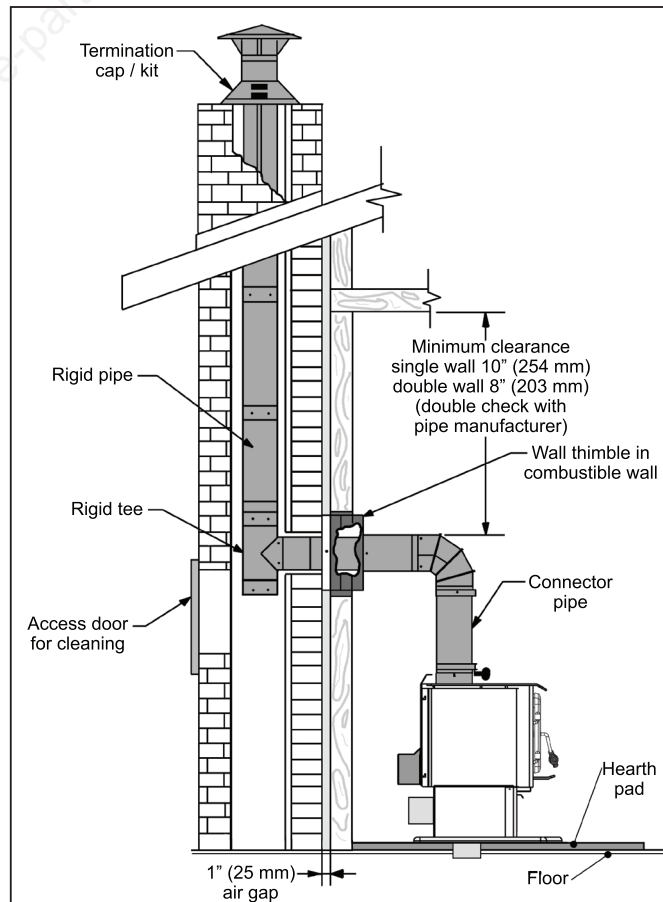
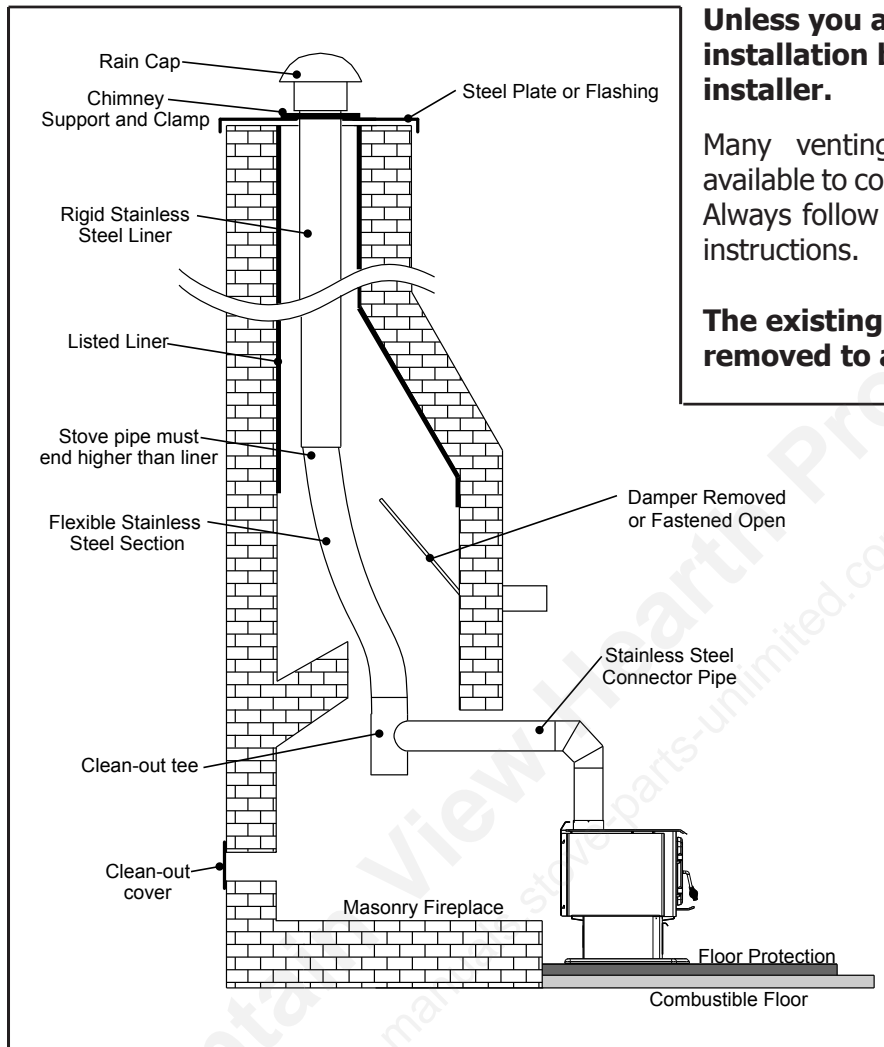

Figure 29: Installation into chimney through a combustible wall.

# INSTALLATION

## MASONRY FIREPLACE INSTALLATION - FREESTANDING:



**Unless you are experienced, we recommend installation by your dealer or a professional installer.**

Many venting manufacturers have listed kits available to connect a stove to a masonry fireplace. Always follow the vent manufacturer's installation instructions.

**The existing damper may have to be removed to allow installation.**

**Figure 30: Freestanding Installation into existing fireplace.**

## MOBILE HOME INSTALLATION:

**SPECIAL REQUIREMENTS:** Pedestal models 1200 and 1700 are approved for mobile homes. A 1200 or 1700 Insert may also be installed into a Mobile Home in the U.S. provided there is a Mobile Home approved Factory Built Fireplace installed with adequate fresh air supply, and that the Factory Built Fireplace is not altered beyond the damper or ash shelf being modified. In Canada, Insert Mobile Home installations must be pre-approved by the local inspector. All freestanding installation requirements in "Installation Of A Listed, Factory Built Chimney", must comply with all local codes that may apply, and the following must be met:

### **VENTING:**

**In Canada:** Any ULC-S629 listed chimney system with the accompanying double-wall vent connector.

**In U.S.A.** Any UL-103-HT listed chimney system with the accompanying double-wall vent connector. Do not connect a listed chimney of one manufacture with a listed double wall connector from another manufacture.

# INSTALLATION

These connectors must be installed in accordance with the manufacturer's instructions. Use only specified components. The chimney and pipe must extend at least 10 feet (2.4 m) above the stove and 3 feet (0.9 m) above the highest point of the roof. Install a rain cap with spark arrestor at the top that will not impede the smoke exhaust. The chimney must be supported at the ceiling or roof so that its weight will not sit on the stove. Seal with silicone to maintain vapor barrier at the chimney and outside air penetrations.

**CAUTION: THE STRUCTURAL INTEGRITY OF THE MOBILE HOME FLOOR, WALL, AND CEILING/ROOF MUST BE MAINTAINED.**

## OUTSIDE AIR :

Connection from the stoves air intake to the outside is **mandatory**, (MOBILE HOMES ONLY) either through a hole in the wall not higher than the stoves bottom or through a hole in the floor beneath the pedestal, using the fresh air adaptor provided. If the air intake is through the floor, the hole in the pedestal back must be closed with the sheet metal cover provided. Avoid cutting any floor joists, wall studs, electrical wiring or plumbing. Seal around the outside air pipe with insulation to prevent drafts. Also install a ¼" mesh rodent or pest screen in the end of fresh-air pipe. Fresh-air connection must be of a non-combustible material, example: 4" (10.16 cm) flexible aluminum single wall pipe.

Fresh air could also be supplied from a **vented crawlspace**.

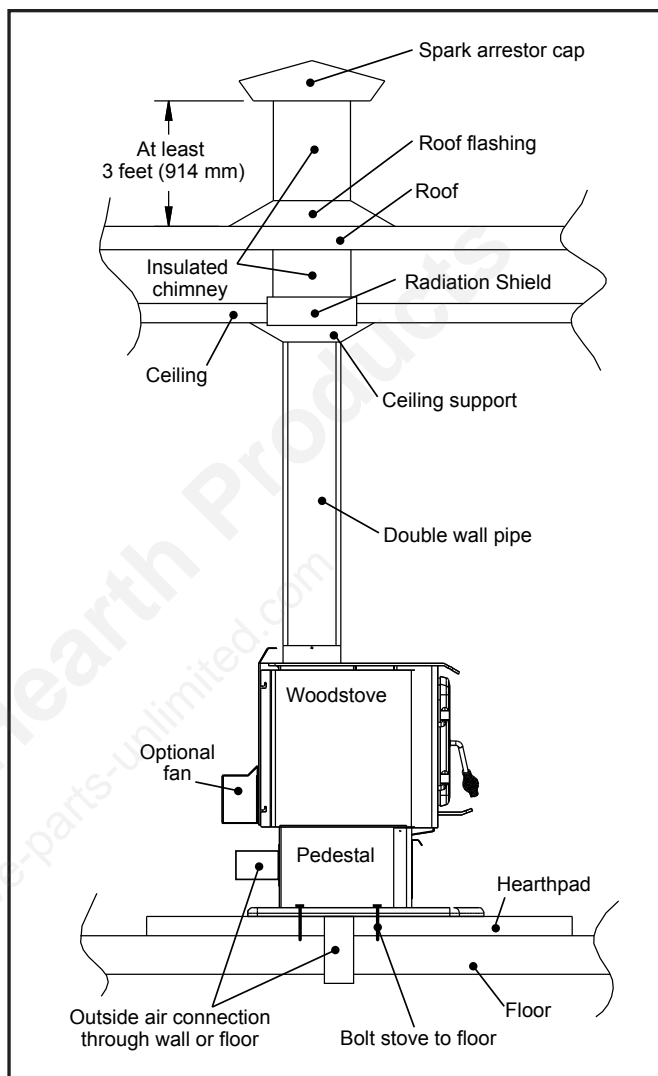

**Figure 31: Freestanding installation into mobile home.**

The pedestal must be firmly bolted to the floor using two (2) ¼" bolts. Be sure to replace any insulation or panels removed when fastening the bottom nuts.

If room air starvation occurs because the air intake is blocked with ice, leaves etc. or because the stove door was left open, or due to a strong exhaust fan operating, dangerous fumes could be sucked into the room.

IN SOME AREAS IT MAY BE REQUIRED TO ELECTRICALLY GROUND THE STOVE TO THE STEEL CHASSIS OF THE MOBILE HOME.

When this unit is installed in a Mobile Home it must be grounded to the steel chassis or connected to a grounding rod.

Manufactured (Mobile) home installation must be in accordance with the Manufactured Home Construction and Safety Standard, UL 307B, Title 24 CFR, Part 3280 and/or The Standard for Manufactured Home Installations, ANSI A225.1/NFPA 501A.

**WARNING: DO NOT INSTALL IN A MOBILE HOME SLEEPING ROOM.**

# INSTALLATION

## MODEL 1200 BRICK PLACEMENT & TUBE LOCATIONS:

COMPLETE THE STOVE AND SMOKE PIPE INSTALLATION BEFORE PLACING THESE BRICKS.

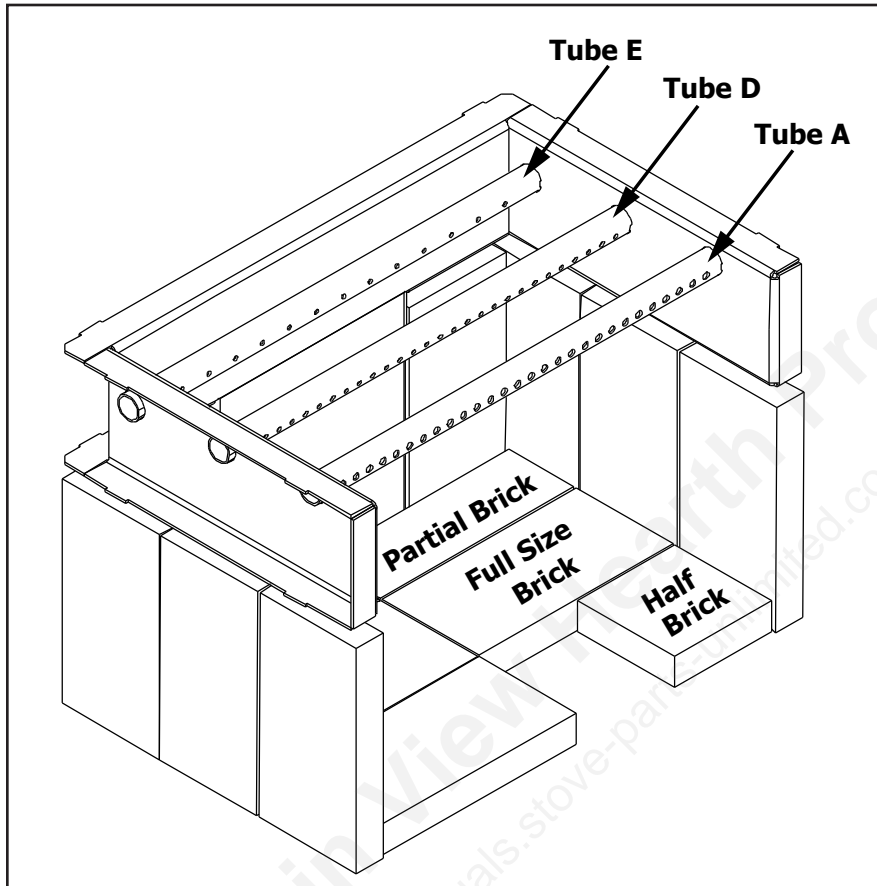

Figure 32: Brick Placement for 1200 shown with Secondary Air Channel and Tubes.

1. Place the three (3) full size bricks along each side of the firebox and one (1) full size brick on either side of the back of the firebox.
2. To place the floor bricks, lay the two (2) partial bricks along the back of the floor. Then on the left, lay two (2) full size bricks and on the right, lay a full size brick in the center and the half brick in the front (for the ash dump). The spaces between the bricks will soon fill with ashes.

When replacing bricks, use only pumas type fire bricks.

### **TOTAL BRICKS:**

- 11 - Full size bricks 9" long x 4.5" wide x 1.25" thick  
(22.9 cm long x 11.4 cm wide x 3.2 cm thick)
- 2 - Partial bricks 9" long x 3" wide x 1.25" thick  
(22.9 cm long x 7.6 cm wide 3.2 cm thick)
- 1 - Half brick 4.5" long x 4.5" wide x 1.25" thick  
(11.43 cm long x 11.43 cm wide x 3.175 cm thick)

**Removing Air Tube:** If a secondary air tube needs to be removed, place a screwdriver (any style except flat head) into one of the air holes and tap it with a hammer/mallet to the left until the right end of the tube is freed. To installation a secondary air tube reverse the above instructions.

**IMPORTANT:** All secondary air tubes must be in place for proper operation.

# INSTALLATION

## MODEL 1700 BRICK PLACEMENT & TUBE LOCATIONS:

COMPLETE THE STOVE AND SMOKE PIPE INSTALLATION BEFORE PLACING THESE BRICKS.

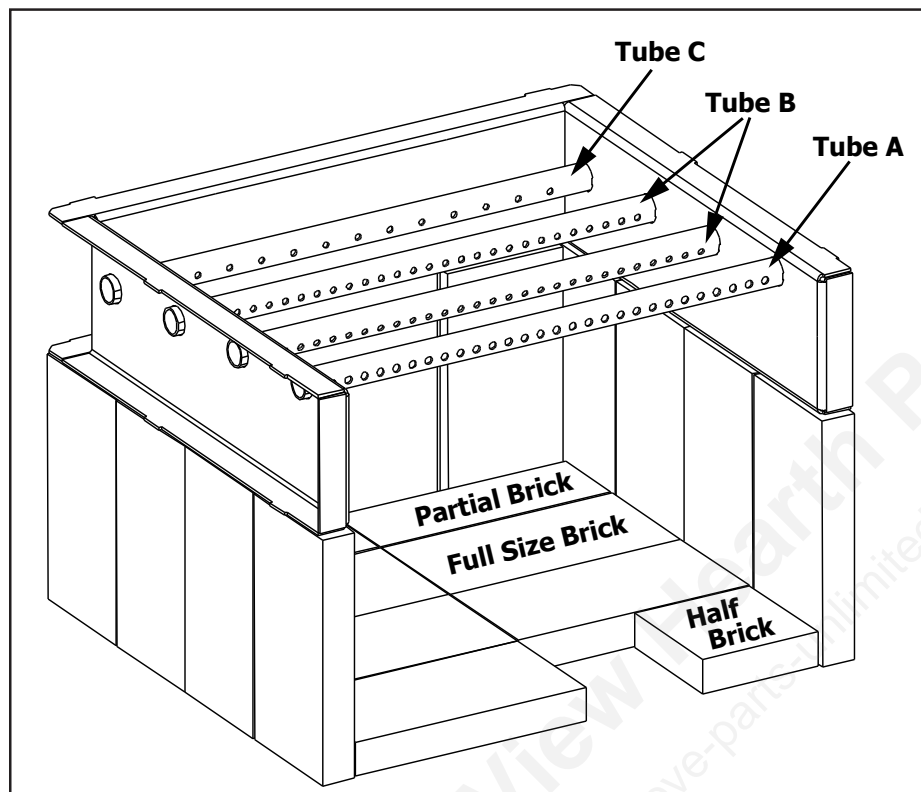

1. Place the four (4) full size bricks along each side of the firebox and one (1) full size brick on either side of the back of the firebox.
2. To place the floor bricks, lay the two (2) partial bricks along the back of the floor. Then on the left, lay three (3) full size bricks and on the right, lay two (2) full size bricks in the center and the half brick in the front (for the ash dump). The spaces between the bricks will soon fill with ashes.

Figure 33: Brick Placement for 1700 shown with Secondary Air Channel and Tubes.

When replacing bricks, use only pumas type fire bricks.

### **TOTAL BRICKS:**

- 15 - Full size bricks 9" long x 4.5" wide x 1.25" thick  
(22.9 cm long x 11.4 cm wide x 3.2 cm thick)
- 2 - Partial bricks 9" long x 3" wide x 1.25" thick  
(22.9 cm long x 7.6 cm wide x 3.2 cm thick)
- 1 - Half brick 4.5" long x 4.5" wide x 1.25" thick  
(11.43 cm long x 11.43 cm wide x 3.175 cm thick)

**Removing Air Tube:** If a secondary air tube needs to be removed, place a screwdriver (any style except flat head) into one of the air holes and tap it with a hammer/mallet to the left until the right end of the tube is freed. To installation a secondary air tube reverse the above instructions.

**IMPORTANT:** All secondary air tubes must be in place for proper operation.

# INSTALLATION

## C-CAST CERAMIC BAFFLE INSTALLATION:

1. Slide the right C-Cast Ceramic Baffle in over the secondary air tubes at the top of the firebox. The tab must be on the top and pointing towards the center and the smooth side is to face down.
2. Hook the outside edge of the baffle over the top of the secondary air chamber. This will make room to for the installation of the left C-Cast Ceramic Baffle.
3. Slide the left C-Cast Ceramic Baffle in over the secondary air tubes. The tab must be on the bottom and pointing towards the center and the smooth side is to face down.
4. Pull the baffles together in the middle so the right tab rests on top of the left tab. Ensure the baffles are flush with the back and both sides of the firebox.

**Note for insert models only:** If the bolts on the flue collar are not to the left and right of the hole, the front secondary air tube will need to be removed in order to install or remove the C-Cast Ceramic Baffles. To remove the front secondary air tube place a screwdriver (any style except flat head) into one of the air holes and tapping it with a hammer/mallet to the left.

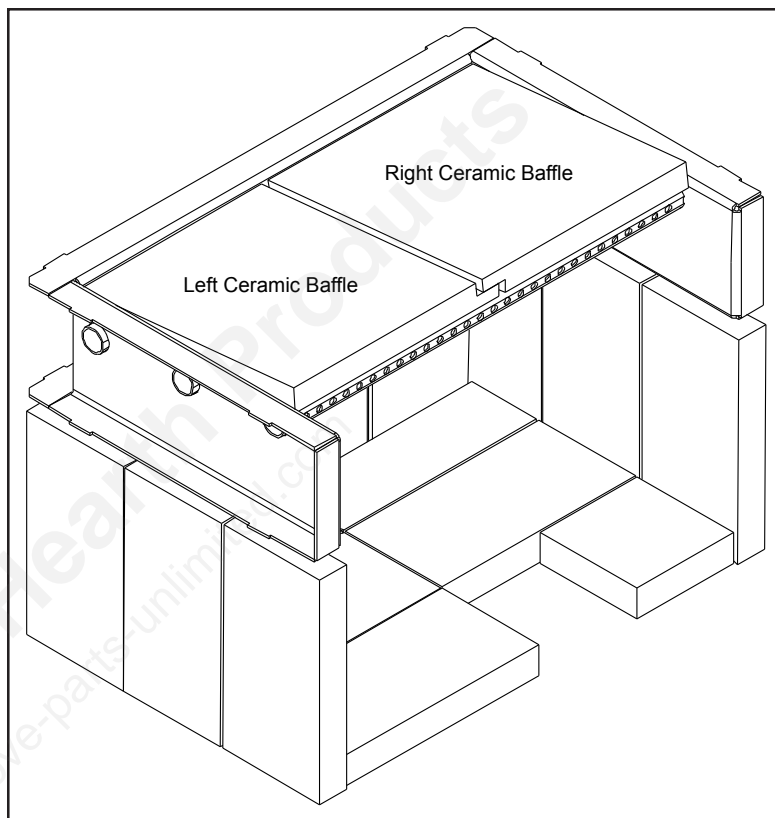

**Figure 34: Installation of C-Cast Ceramic Baffle.**

## FAN WIRING DIAGRAMS:

This appliance, when installed, must be electrically connected and grounded in accordance with local codes or in the absence of local codes, with the current CSA C22.1 CANADIAN ELECTRICAL CODE. Part 1, SAFETY STANDARDS FOR ELECTRICAL INSTALLATIONS, or THE NATIONAL ELECTRICAL CODE ANSI / NFPA 70 in the USA.

**CAUTION** Label all wires prior to disconnection when servicing controls. Wiring errors can cause improper and dangerous operation. Verify proper operation after servicing.

**DO NOT** oil the fan bearings.

**DO NOT** cut or remove the grounding prong from the plug.

**DO NOT** route the power cord beneath the heater.

**WARNING:** This appliance is equipped with a three-prong (grounding) plug for your protection against shock hazard and should be plugged into a properly grounded three-prong receptacle.

# INSTALLATION

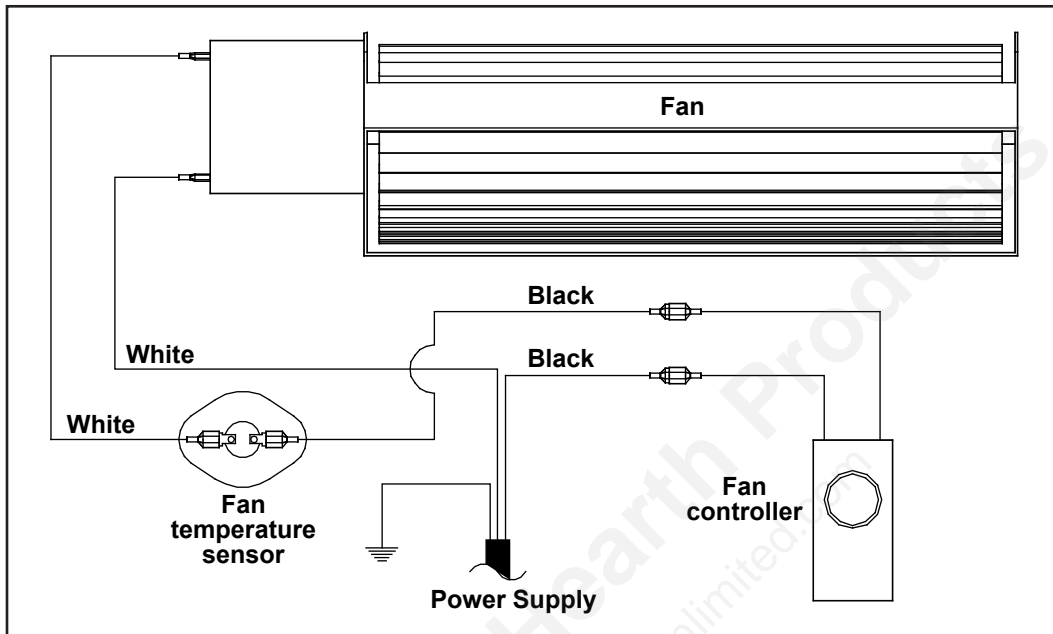

Figure 35: Freestanding Fan Kit Wiring Diagram.

## OPTIONAL FAN INSTALLATION - FREESTANDING:

Refer to FAN WIRING DIAGRAM before installing your optional fan kit.

1. Remove the fan assembly from the box and inspect for any damage to the assembly. If damage is noticed call your dealer, distributor or courier company and have components replaced before installing kit.
2. Remove the knock out at the bottom of the back panel of the appliance by using a flat head screwdriver as a lever, hook the tip of the screwdriver under the panel beside the tabs and push the panel out.
3. Install two (2) T-20 screws into the top two (2) holes. Place the blower assembly over these two (2) screws.
4. Ensure the temperature sensor will touch the unit when mounted. If it does not touch, adjust the sensor so it does. Tighten the two (2) top screws and install the two (2) bottom screws and tighten.
5. Plug the fan assembly in and check for proper operation.

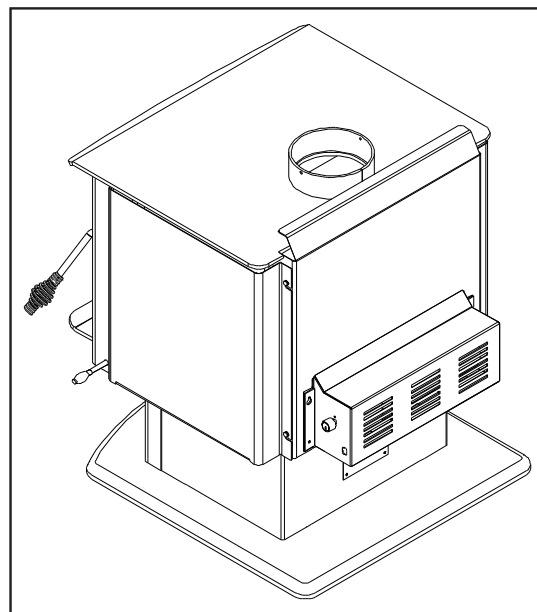

Figure 36: Back View of Freestanding Unit with Fan Kit.

# RATING LABEL

XXXXXXXXXXXX

Tested & Listed By **O-T-L** Portland Oregon USA  
 OMNI-Test Laboratories, Inc.  
 Certified for use in Canada & USA  
 Certifié pour installation au Canada et aux États-Unis.

## DO NOT REMOVE THIS LABEL / NE PAS ENLEVER CETTE ÉTIQUETTE LISTED SOLID FUEL SPACE HEATER / IDENTIFIEZ COMME UN FOYER A COMBUSTIBLE SOLIDE

- Boston 1200 FS 268-S-04b-2   
  Kodiak 1200 FS 268-S-04b-2   
  Boston 1200 FPI 268-S-06c-2   
  Venice 1200 FPI 268-S-05-2   
  1200 KI FPI 268-S-05-2  
 Boston 1700 FS 268-S-01b-2   
  Kodiak 1700 FS 268-S-01b-2   
  Boston 1700 FPI 268-S-06c-2   
  Venice 1700 FPI 268-S-06c-2   
  1700 KI FPI 268-S-06c-2

Serial No. / No. De Série:

Models 1200 and 1700 Freestanding units: Room Heater, Solid Fuel Type, Also For Use in Mobile Homes. Tested to ULC-S627-00, ULC-S628-93 (FPI only), & UL-1482-1.

Install and use only in accordance with the manufacturer's installation and operating instructions. Contact local building or fire officials about restrictions and installation inspection in your area. Use 6" (150 mm) diameter minimum 24 MSG black or 25 MSG blue steel connector listed factory-built chimney suitable for use with solid fuels or masonry chimney. See local building code and manufacturer's instructions for precautions required for passing a chimney through a combustible wall or ceiling. Do not pass chimney connector through a combustible wall or ceiling. Minimum clearances from horizontal connector and ceiling 18" (455 mm). Do not connect this unit to a chimney flue servicing another appliance.

Models 1200 et 1700 items indépendants: Chauffage pièce, le type de combustible solide, également pour une utilisation dans les maisons mobiles. Testé selon ULC-S627-00, ULC-S628-93 (FPI seulement), & UL-1482-1.

Ce dispositif doit être installé et opéré conformément aux instructions d'installation et d'opération du fabricant. Contactez le service local de l'inspection des bâtiments ou l'officier pompier concernant les restrictions et l'inspection d'installation dans votre localité. Utilisez des connecteurs répertoriés 24 MSG noir ou 25 MSG en acier inoxydable de 6" (150 mm) minimum, et une cheminée de fabrication industrielle, appropriée pour utilisation avec des combustibles solides ou avec une cheminée de maçonnerie. Vérifiez les précautions à prendre exigées par le code local et les instructions du fabricant concernant les conditions pour passer la cheminée à travers un mur ou un plafond combustible. Ne pas installer le connecteur de la cheminée à travers un mur ou un plafond combustible. Espaces libres minimum d'un connecteur horizontal et plafond sont 18" (455 mm) ne pas connecter ce dispositif à un conduit de cheminée qui sert déjà un autre dispositif.

U.S. ENVIRONMENTAL PROTECTION AGENCY Certified to comply with 2015 particulate emission standards. Not approved for sale after May 15, 2020. This wood heater needs periodic inspection and repair for proper operation. Consult the owner's manual for further information. It is against federal regulations to operate this heater in a manner inconsistent with the operating instructions in the owner's manual. This heater meets the 2015 U.S. Environmental Protection Agency's wood emission limits for wood units sold after May 15, 2015. Under specific test conditions the 1200 heater has been shown to have a particulate emission level of 3.4 g/hr. Under specific test conditions the 1700 heater has been shown to have a particulate emission level of 4.5 g/hr.

Minimum Clearances to Combustible Materials / Espaces Libres Aux Matériaux Combustibles.	Single wall pipe / Seul connecteur de mur		**Double wall pipe / Double connecteur de mur		Double wall pipe with efficiency shield (Flat top model only) / Double connecteur de mur avec la protection d'efficacité (Le modèle plat seulement)		Top vent out back wall with min. 24" (610mm) vertical rise, double wall pipe / Double vent hors de la paroi arrière avec le min. 24" (610 mm) l'ascension verticale; double connecteur de mur	
	Model / Modèle	1200	1700	1200	1700	1200	1700	1200
A Sidewall to unit / De la paroi latérale au dispositif	13" (330 mm)	20" (508 mm)	13" (330 mm)	13" (330 mm)	13" (330 mm)	13" (330 mm)	14" (356 mm)	11" (279 mm)
B Backwall to unit / De la paroi arrière au dispositif	11" (279 mm)	12" (305 mm)	10" (254 mm)	10" (254 mm)	8" (203 mm)	7" (178 mm)	12" (305 mm)	13" (330 mm)
C Adjacent wall to corner of unit / De la paroi adjacente au coin de dispositif	9" (229 mm)	10" (254 mm)	8" (203 mm)	8 1/2" (216 mm)	6 1/2" (165 mm)	6" (152 mm)		
D Sidewall to connector / De la paroi latérale au connecteur	22" (559 mm)	29" (737 mm)	22" (559 mm)	22" (559 mm)	22" (559 mm)	22" (559 mm)	23" (584 mm)	16" (381 mm)
E Backwall to connector / De la paroi arrière au connecteur	14" (356 mm)	15" (381 mm)	13" (330 mm)	13" (330 mm)	11" (279 mm)	10" (254 mm)	15" (381 mm)	15" (406 mm)
F Adjacent wall to connector / De la paroi adjacente au connecteur	17 1/2" (445 mm)	18 1/2" (470 mm)	16 1/2" (419 mm)	17" (432 mm)	15" (381 mm)	14 1/2" (368 mm)		
G † Front of door opening to edge of hearth / Le devant d'ouverture de porte au bord de coussin de cœur					USA 16" (406 mm) CND 18" (450 mm)			
H † Side/back of unit to edge of hearth / Le latérale/arrière de dispositif au bord de coussin de cœur					USA 6" (152 mm) CND 8" (200 mm)			

CAUTION: An uninsulated smoke pipe must not pass through an attic, roof space, closet or similar concealed space, or through a floor, ceiling, wall, or partition, or any combustible construction.  
 † FLOOR PROTECTION: If a stove is installed on a combustible floor, it must have the legs or pedestal attached and be on a NON COMBUSTIBLE hearth pad.  
 \* ALL CLEARANCES CAN BE REDUCED WITH SHIELDING ACCEPTABLE TO THE LOCAL AUTHORITY.  
 SINGLE WALL: Any ULC-S629 listed chimney system with the accompanying listed single wall vent connector. In U.S.A.: Any UL 103 HT listed chimney system with the accompanying listed single wall vent connector.  
 \*\*DOUBLE WALL: In CANADA: Any ULC-S629 listed chimney system with the accompanying listed double wall vent connector. In U.S.A.: Any UL 103 HT listed chimney system with the accompanying listed double wall vent connector.  
 DOUBLE WALL IS REQUIRED FOR MOBILE HOME INSTALLATIONS.

MISE EN GARDE: Un insulated tuyau de fumée ne doit pas passer par un grenier, un espace de toit, le placard ou l'espace dissimulé similaire, ou par un plancher, un plafond, un mur, ou une cloison, ou une construction combustible.  
 † PROTÉGER LE PLANCHER: Si une cuisinière est installée sur un sol combustible, il doit avoir un piédestal attaché et être sur un coussinet non combustible.  
 \* TOUS ESPACES LIBRES AUX MATÉRIEL COMBUSTIBLES PEUVENT ÊTRE RÉDUITS AVEC PROTÉGÉANT ACCEPTABLE À L'AUTORITÉ LOCALE.  
 Seul Connecteur de Mur: Au Canada: Certifiée seul connecteur de mur avec toute systèmes de cheminée listée sous ULC-S629. Aux États-Unis: Certifiée seul connecteur de mur avec toute systèmes de cheminée listée sous UL 103 HT.  
 \*\*Double Connecteur de Mur: Au Canada: Certifiée double connecteur de mur avec toute systèmes de cheminée listée sous ULC-S629. Aux États-Unis: Certifiée double connecteur de mur avec toute systèmes de cheminée listée sous UL 103 HT.

**Alcove (Use double wall pipe) / Alcôve (Utilisant le double connecteur de mur)	Model/Modèle 1200	Model/Modèle 1700
I Total width / Largeur totale	55" (1397 mm)	51" (1295 mm)
J Total height / Hauteur totale	78" (1981 mm)	72" (1829 mm)
K Top of stove to ceiling / Le sommet de poêle au plafond	49" (1245 mm)	44" (1118 mm)
L Sidewall to unit / De la paroi latérale au dispositif	15" (381 mm)	13" (330 mm)
M Sidewall to connector / De la paroi latérale au connecteur	24" (610 mm)	22" (559 mm)
N Backwall to unit / De la paroi arrière au dispositif	12" (305 mm)	8" (203 mm)
O Backwall to connector / De la paroi arrière au connecteur	15" (381 mm)	11" (279 mm)
P Maximum Depth / Profondeur maximum	48" (1220 mm)	48" (1220 mm)

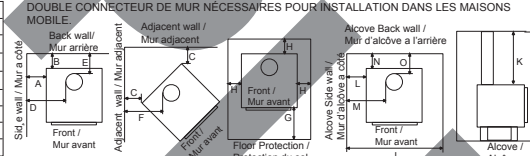

Models 1200 and 1700 inserts may be installed as an insert in a masonry fireplace. / On peut encastrier les modèles 1200 et 1700 dans un foyer de maçonnerie.

Model / Modèle	1200 FPI	1700 FPI
A To unshielded side wall / aux mur non protégé	10" (254 mm)	10" (254 mm)
B To an unshielded 8" (203 mm) mantle / aux manteau 8" non protégé	21" (533 mm)	24" (610 mm)
C To top facing (protruding 1/2" (19 mm) clearance / aux revêtement supérieur	17 1/2" (445 mm)	19 1/2" (495 mm)
D To side facing (protruding 1/2" (19 mm) clearance / aux revêtement à côté	1" (25 mm)	1" (25 mm)
E † From door opening of unit to edge of floor protection / De ouverture de la porte de l'unité à bord de la protection de plancher	USA 16" (406mm) / CND 18" (450mm)	
F † From side of unit to edge of floor protection / Du côté de l'unité au bord de la protection de plancher	USA 6" (152 mm) / CND 8" (200 mm)	

† FLOOR PROTECTION / PROTÉGER LE PLANCHER: If unit is raised / Si l'appareil est soulevé: 0" - 2" (0mm - 51mm); 1" (25mm) non-combustible material with R = 1.19 or equivalent / 2" - 8" (51mm - 203mm); 1/2" (13mm) non-combustible material with R = 1.19 or equivalent / Greater than/Plus grand que 8" (203 mm) any non-combustible material / n'importe quel type de matériel incombustible.

OPERATE ONLY WITH DOORS CLOSED. Only open door to feed fire. For use with solid wood fuels only. Do not use any other type of fuel. Do not use grate or elevate-fire build wood fire directly on hearth. Do not overfire. Do not obstruct beneath the heater. If heater or chimney connector glows, you are overfiring. Inspect and clean chimney frequently under certain conditions of use, creosote buildup may occur rapidly. The provided insulation materials are required for operation. Keep furnishing and other combustibles well away from heater. Replace glass only with 5 mm thick ceramic glass. Optional component for FS: fan, electrical rating 115V, 60 Hz 1 Amp (Part # EFW-261). Combustion air openings are not to be obstructed.  
 Danger: Risk of electrical shock. Disconnect power before servicing unit. Route cord away from heater.

L'OPÉRATION DU POÊLE DOIT SE FAIRE AVEC LA PORTE FERMÉE. N'ouvrez la porte que pour alimenter le feu. N'utilisez que des combustibles solides. Ne pas utiliser un autre type de carburant. N'employez pas de grille ou ne surélevez pas le feu. Mettez le bois à brûler directement sur l'âtre. Pour éviter la surchauffe, ne mettez pas trop de bois. N'ouvrez pas les ouvertures d'air comburant. Si le poêle ou le connecteur commencent à luire, vous surchauffez le poêle; inspectez et nettoyez la cheminée souvent. Dans certaines conditions, le créosote peut s'accumuler rapidement. Les matériaux d'isolation fournis sont requis pour l'opération. Tenez loin les meubles et d'autres produits combustibles. Ne remplacez le verre qu'avec du verre céramique, 5mm épais. Equipement en option pour un FS: ventilateur caractéristiques assignées 115V, 60 Hz, 1 Amp (pièce # EFW-261) tenez le câble électrique loin du poêle. Danger: Le risque de choc électrique. Débrancher le dispositif avant d'entretenir. Ouvertures d'air de combustion ne doivent pas être obstrués.

**CAUTION:** HOT WHILE IN OPERATION. DO NOT TOUCH. KEEP CHILDREN, CLOTHING AND FURNITURE AWAY. CONTACT MAY CAUSE SKIN BURN. READ NAMEPLATE AND INSTRUCTIONS.

**MISE EN GARDE:** TRÈS CHAUD QUAND ALLUMÉ. NE TOUCHEZ PAS. TENIR LOIS LES ENFANTS, LES VÊTEMENTS ET LES MEUBLES. LE CONTACT PEUT CAUSER DES BRÛLURES. LISEZ ATTENTIVEMENT L'ÉTIQUETTE ET LES INSTRUCTIONS.

MADE IN CANADA / FABRIQUE AU CANADA MANUFACTURED BY / FABRIQUE PAR: SHERWOOD INDUSTRIES LTD. 6782 OLDFIELD ROAD, SAANICHTON, BC CANADA  
 DATE OF MANUFACTURE / DATE DE FABRICATION: J F M A M J J A S O N D 2015 2016 2017 2018 2019 C-14615



# PARTS LIST

Reference #	Description	Part #
5	Door Gasket - 7 feet (2.13m)	EF-168
	Fresh Air Kit	EF-186
6	One Leg - Painted	EFW-253
6	One Leg - Gold	EFW-254
6	One leg - nickel	EFW-255
7	Freestanding Fan Kit	EFW-261
7	1200 & 1700 Freestanding Convection Blower - 115V	EC-069
8	Glass with Tape	10-000
9	Damper Handle Spring - Brass	EF-191
9	Damper Handle Spring - Nickel	10-005
10	Door Handle Spring - Brass	10-006
10	Door Handle Spring - Nickel	10-007
	Enviro Logo Gel Decal	50-322
11	1200 Leg Kit with ash drawer - Nickel	50-979
11	1200 Leg Kit with ash drawer - Gold	50-980
11	1200 Leg Kit with ash drawer - Painted	50-981
11	1200 Leg Kit with ash drawer - Brushed Nickel	50-1470
12	1200 Freestanding Pedestal - Painted	50-982
13	1700 Leg Kit with ash drawer - Nickel	50-983
13	1700 Leg Kit with ash drawer - Gold	50-984
13	1700 Leg Kit with ash drawer - Painted	50-985
13	1700 Leg Kit with ash drawer - Brushed Nickel	50-1471
14	1700 Freestanding Pedestal - Painted	50-986
15	Door - Painted	50-2897
15	Door - Gold	50-2898
15	Door - Nickel	50-2899
15	Door - Nickel Trim	50-2904
15	Door - Gold Trim	50-2903
16	Owner's Manual	50-2920
17	Heat Efficiency Shield	50-1088
18	1200 & 1700 Front Secondary Air Tube A	50-1099
19	1700 Rear Secondary Air Tube C	50-1100
20	1700 Middle Secondary Air Tube B	50-1101
21	1200 Rear Secondary Air Tube E	50-1102
22	1200 Middle Secondary Air Tube D	50-1103
23	Pumice Bricks - 3" X 9" (76mm x 229mm)	50-1104

# PARTS LIST

Reference #	Description	Part #
24	Pumice Bricks - 4½" X 9" (114mm x 229mm)	50-1105
25	Pumice Bricks - 4½" X 4½" (114mm x 114mm)	50-1106
26	1200 & 1700 Cast Ash Plug	50-1120
27	Door Handle Assembly (Rod, Cast Latch, Brass Spring)	50-1121
27	1200 & 1700 Cast Latch	50-1381
28	Wood Door Glass Retainer Kit (With Screws)	50-1122
29	1200 Freestanding Flat Top Left Side Cabinet	50-1123
30	1200 Freestanding Flat Top Right Side Cabinet	50-1124
31	1200 Freestanding Step Top Left Side Cabinet	50-1125
32	1200 Freestanding Step Top Right Side Cabinet	50-1126
33	1700 Freestanding Flat Top Left Side Cabinet	50-1127
34	1700 Freestanding Flat Top Right Side Cabinet	50-1128
35	1700 Freestanding Step Top Left Side Cabinet	50-1129
36	1700 Freestanding Step Top Right Side Cabinet	50-1130
37	1200 & 1700 Leg Kit Ash Drawer	50-1131
38	1200 Leg Kit Ash Drawer Box	50-1132
39	1700 Leg Kit Ash Drawer Box	50-1133
40	1200 Leg Kit Adaptor Plate	50-1134
41	1700 Leg Kit Adaptor Plate	50-1135
42	1200 & 1700 Pedestal Kit Ash Drawer	50-1136
43	1200 & 1700 Left Shield Assembly	50-1144
44	1200 & 1700 Right Shield Assembly	50-1145
45	1200 C-Cast Ceramic Baffle - 1 Piece	50-1146
46	1700 C-Cast Ceramic Baffle - 1 Piece	50-1147
50	1200 & 1700 Door Hinge Pin Cap	50-1815
51	Wood Handle w/ Hardware	50-2909

# PARTS DIAGRAM - FREESTANDING

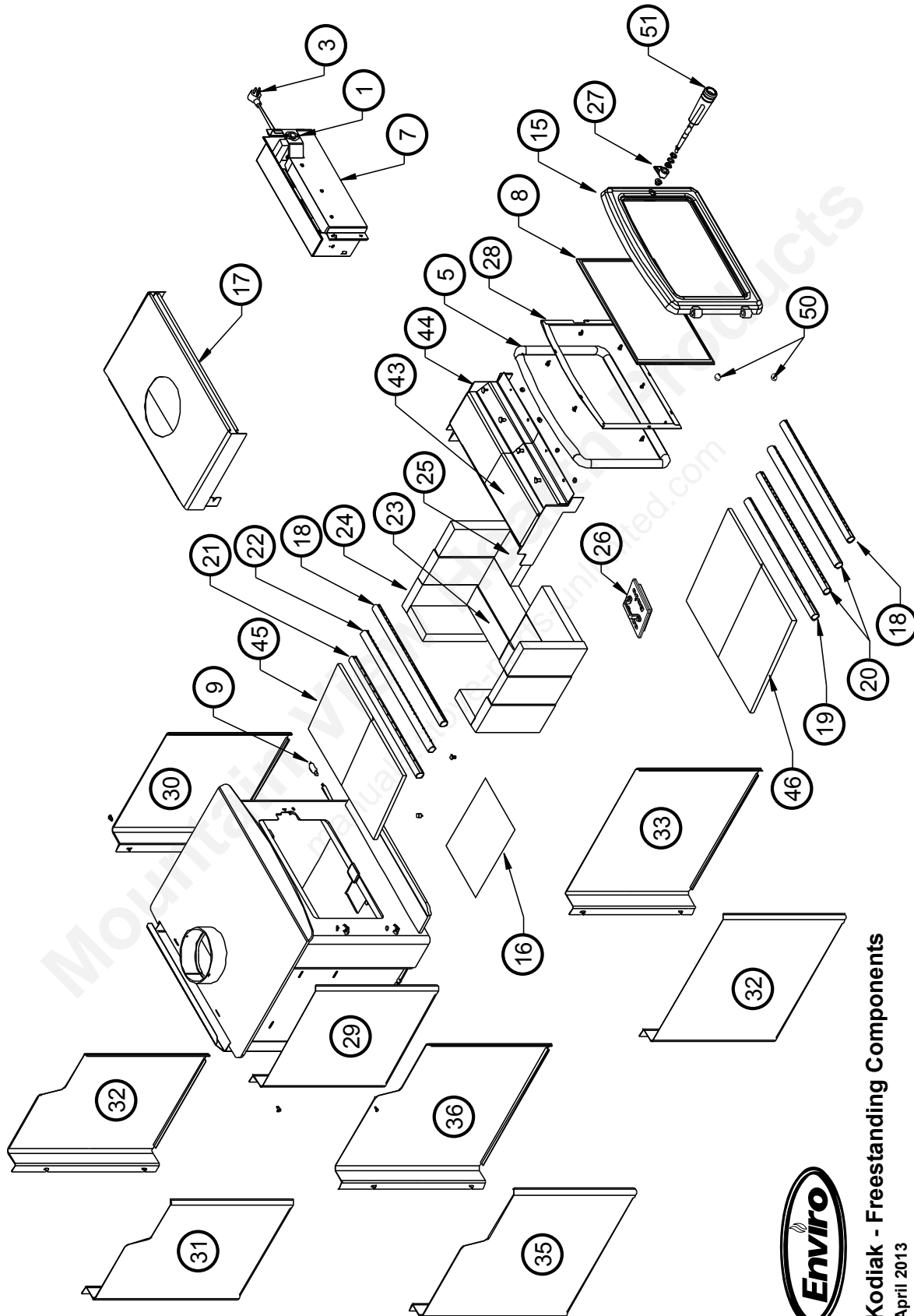

**Kodiak - Freestanding Components**  
April 2013

# PARTS DIAGRAM - PEDESTALS & LEGS



Kodiak - Pedestal and Leg Kit Components  
March 2008

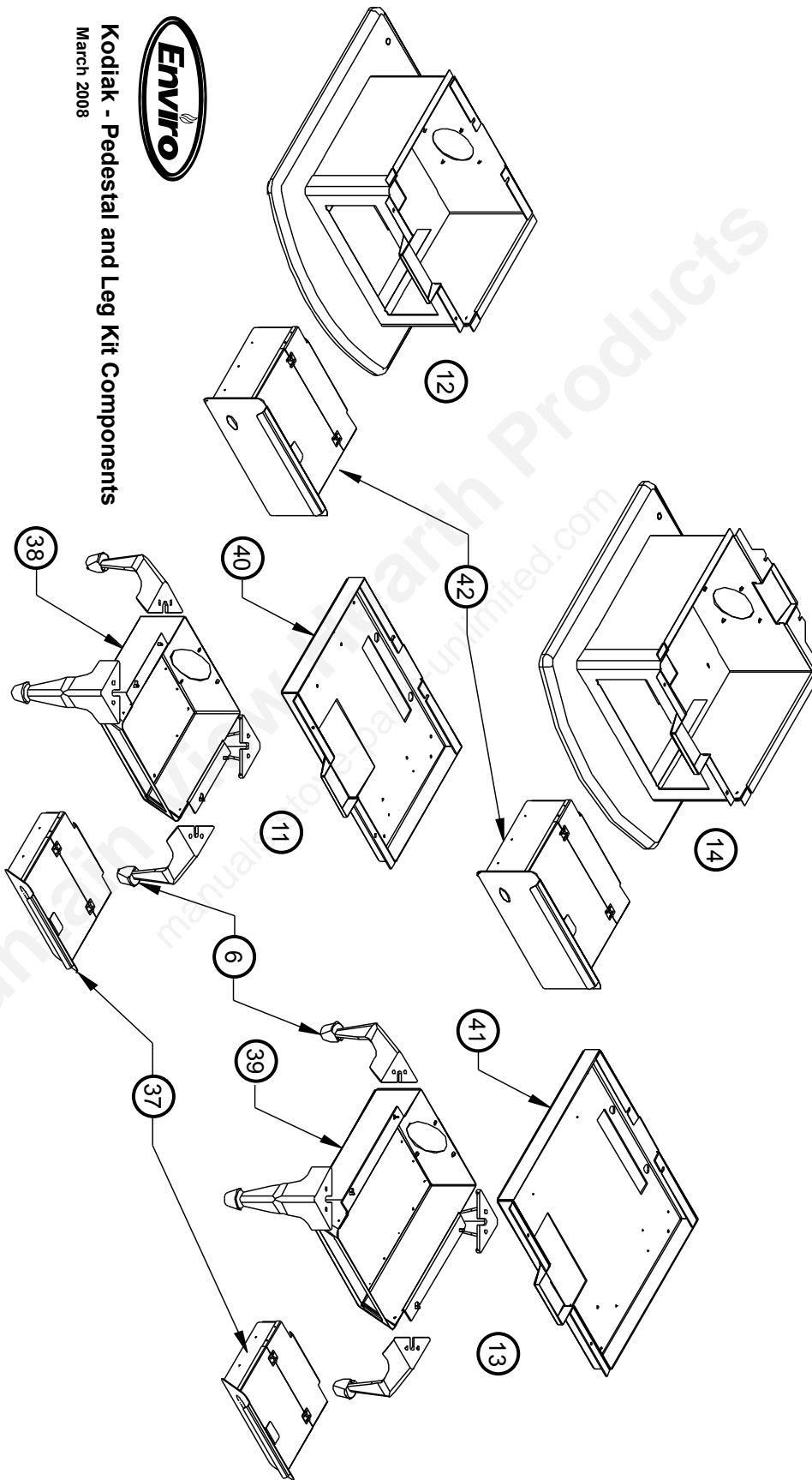

# NOTES

---

Mountain View Hearth Products  
manuals.stove-parts-unlimited.com

# NOTES

---

Mountain View Hearth Products  
manuals.stove-parts-unlimited.com

# NOTES

---

Mountain View Hearth Products  
manuals.stove-parts-unlimited.com



# Warranty for Enviro Wood Products

Sherwood Industries Ltd. ("Sherwood") hereby warrants, subject to the terms and conditions herein set forth, this product against defects in material and workmanship during the specified warranty period starting from the date of original purchase at retail. In the event of a defect of material or workmanship during the specified warranty period, Sherwood reserves the right to make repairs or to assess the replacement of a defective product at Sherwood's factory. The shipping costs are to be paid by the consumer. All warranties by Sherwood are set forth herein and no claim shall be made against Sherwood on any oral warranty or representation.

## Conditions

- A completed warranty registration must be submitted to Sherwood within 90 days of original purchase via the online warranty registration page or via the mail-in warranty registration card provided. Have the installer fill in the installation data sheet in the back of the manual for warranty and future reference.
- This warranty applies only to the original owner in the original location from date of install.
- The unit must have been properly installed by a qualified technician or installer, and must meet all local and national building code requirements.
- The warranty does not cover removal and re-installation costs.
- Sherwood Industries Ltd. reserves the right to make changes without notice.
- Sherwood Industries Ltd. and its employees or representatives will not assume any damages, either directly or indirectly caused by improper usage, operation, installation, servicing or maintenance of this appliance.
- A proof of original purchase must be provided by you or the dealer including serial number.

## Exclusions

An expanded list of exclusions is available at [www.enviro.com/help/warranty.html](http://www.enviro.com/help/warranty.html)

This warranty does not cover:

- Damage as a result of improper usage or abuse.
- Damage caused from over-firing due to incorrect setup or tampering.
- Damage caused by incorrect installation.

## To the Dealer

- Provide name, address and telephone number of purchaser and date of purchase.
- Provide date of purchase. Name of installer and dealer. Serial number of the appliance. Nature of complaint, defects or malfunction, description and part # of any parts replaced.
- Pictures or return of damaged or defective product may be required.

## To the Distributor

- Sign and verify that work and information are correct.

## Sherwood Industries Ltd.

6782 Oldfield Road, Victoria, BC . Canada V8M 2A3

Online warranty registration: [www.enviro.com/warranty/](http://www.enviro.com/warranty/)

Category	One Year	Two Year	Limited Lifetime (7yr)
Parts <sup>1</sup> (unit serial number required)		✓	
Firebox (excluding bricks) <sup>2</sup>			✓
Ceramic Baffle <sup>3</sup>			✓
Secondary Air Tubes			✓
Surround Panels (excluding finish)			✓
Pedestals / Legs (excluding finish)			✓
Ceramic Glass <sup>4</sup>	✓		
Door Assembly (excluding gasket)			✓
Slider Control			✓
Shield Assembly			✓
Electrical Components		✓	
Convection Fan		✓	
Exterior Surface Finishing <sup>5</sup>	✓		
Gasket	✓		
Labour		✓	

<sup>1</sup> Whereas warranty has expired, replacement parts will be warranted for 90 days from part purchase date. Labour not included.

Unit serial number required.

<sup>2</sup> Warranty does not cover damage caused from burning artificial/firestarter log varieties.

<sup>3</sup> Excludes damage caused by loading wood, cleaning or service.

<sup>4</sup> Glass is covered for thermal breakage. Photos of box, inside of door, and unit serial # must be supplied for breakage due to shipping.

<sup>5</sup> Exterior Surface finishing covers Plating, Enamel or Paint and excludes colour changes, chipping, and fingerprints.

Travel costs not included.

No warranty on replacement firebricks

# INSTALLATION DATA SHEET

The following information must be recorded by the installer for warranty purposes and future reference.

NAME OF OWNER: \_\_\_\_\_

ADDRESS: \_\_\_\_\_  
\_\_\_\_\_  
\_\_\_\_\_

PHONE: \_\_\_\_\_

NAME OF DEALER: \_\_\_\_\_

ADDRESS: \_\_\_\_\_  
\_\_\_\_\_  
\_\_\_\_\_

PHONE: \_\_\_\_\_

MODEL: \_\_\_\_\_

SERIAL NUMBER: \_\_\_\_\_

DATE OF PURCHASE: \_\_\_\_\_ (dd/mm/yyyy)

DATE OF INSTALLATION: \_\_\_\_\_ (dd/mm/yyyy)

INSTALLER'S SIGNATURE: \_\_\_\_\_  
\_\_\_\_\_

NAME OF INSTALLER: \_\_\_\_\_

ADDRESS: \_\_\_\_\_  
\_\_\_\_\_  
\_\_\_\_\_

PHONE: \_\_\_\_\_

MANUFACTURED BY:  
SHERWOOD INDUSTRIES LTD.  
6782 OLDFIELD RD. SAANICHTON, BC, CANADA V8M 2A3  
www.enviro.com  
October 28, 2015  
C-14582